

BEST AVAILABLE COPY

UNCLASSIFIED

AD 276 510

*Reproduced
by the*

ARMED SERVICES TECHNICAL INFORMATION AGENCY
ARLINGTON HALL STATION
ARLINGTON 12, VIRGINIA



UNCLASSIFIED

BEST AVAILABLE COPY

NOTICE: When government or other drawings, specifications or other data are used for any purpose other than in connection with a definitely related government procurement operation, the U. S. Government thereby incurs no responsibility, nor any obligation whatsoever; and the fact that the Government may have formulated, furnished, or in any way supplied the said drawings, specifications, or other data is not to be regarded by implication or otherwise as in any manner licensing the holder or any other person or corporation, or conveying any rights or permission to manufacture, use or sell any patented invention that may in any way be related thereto.

NOLTR 61-135

3

CATALOGUE BY ASTIA
AS AD NO. 276 510

276 510

A BALLISTICS RANGE STATION
IDENTIFICATION SYSTEM TO BE
USED IN CONJUNCTION WITH A
DATA RECORDER-REPRODUCTION

NOL

6 DECEMBER 1961

UNITED STATES NAVAL ORDNANCE LABORATORY, WHITE OAK, MARYLAND

NOLTR 61-135

ND

N 62-3-6

UNCLASSIFIED
NOLTR 61-135

Ballistics Research Report 55

A BALLISTICS RANGE STATION IDENTIFICATION SYSTEM
TO BE USED IN CONJUNCTION WITH A DATA RECORDER-REPRODUCER

Prepared by:

R. C. Folz

ABSTRACT: A ballistics range station identification system has been designed and constructed that provides a unique correlation of a series of elapsed time measurements as recorded by a data recorder-reproducer, with their respective sources. The final data readout is presented in a visual manner and is also automatically printed out by a Flexowriter. The identifying information is presented with the elapsed time data for each measurement that was recorded.

PUBLISHED MAY 1962

U. S. NAVAL ORDNANCE LABORATORY
WHITE OAK, MARYLAND

1
UNCLASSIFIED

6 December 1961

A BALLISTICS RANGE STATION IDENTIFICATION SYSTEM TO BE USED
IN CONJUNCTION WITH A DATA RECORDER-REPRODUCER

This work was sponsored by the Re-Entry Body Section of the Special Projects Office, Bureau of Naval Weapons, under the Applied Research Program in Aeroballistics.

The author wishes to acknowledge the assistance of Mr. J. W. Roberts for his aid in devising the technique used in coding the stations. The author also wishes to express his appreciation to Messrs. J. Barbera and L. Raborg for their assistance in the construction and installation of the many electronic circuits that constitute the system.

W. D. COLEMAN
Captain, USN
Commander

A. E. Seigel
A. E. SEIGEL
By direction

	Page
Introduction	1
Description of the System.	1
Record Mode Operation	2
Playback Mode Operation	3
Comments	4
References.	6

ILLUSTRATIONS

Figure	Title
1	Simplified Record Flow Diagram
2	Diode Matrix For Converting to Binary Coded Decimal
3	Typical Record Channel Block Diagram
4	Schematic Diagram of Record Preamplifier and Blocking Oscillator
5	One Shot Multivibrator Schematic
6	Simplified Playback Flow Diagram
7	Typical Shot Data Sheet
8	Typical Playback Channel Block Diagram
9	Thyratron Relay Storage and Code Converter

INTRODUCTION

The Data Recorder-Reproducer (DRR), see reference (a), is an elapsed time measuring system. This system accepts a series of voltage pulses and records, on a magnetic drum, the time of occurrence of each of these data pulses relative to an initial pulse which is used as a fiducial timing pulse. A series of time measurements is obtained from which the precise elapsed time between the occurrence of the data pulses and the fiducial pulse can be determined. In the ballistics range operations at the Naval Ordnance Laboratory, this series of voltages is derived from the triggering of instrumented photographic stations as a projectile progresses down the range (see ref. (b)).

The means of distinguishing between the individual photographic stations is by assigning a decimal number to each station. This assignment is completely arbitrary and serves only to correlate the several types of data obtained at each station with their source. The range station identification system provides the means of correlating the time data as recorded by the DRR with the particular station from which it originated.

The station identification system is an auxiliary system to the DRR and it makes use of six available channels on the magnetic drum in the DRR. The auxiliary system uses a binary coded decimal (BCD) number system and with six recording channels available, 39 individual range stations can be identified. If a greater capacity is desired, additional channels can be incorporated or a different coding technique can be used. The system operates in conjunction with the DRR as shown in figures 1 and 6 and as described below.

DESCRIPTION OF THE SYSTEM

The ballistics range station identification system operates on the principle of converting the assigned decimal number of the individual range stations into a binary coded form which can then be handled by normal digital techniques. The digitized information is amplified and recorded on a magnetic drum in the DRR along with the appropriate time interval data. When information readout is desired the recorded data are played back through individual amplifier channels, converted back to decimal form, displayed visually on indicator tubes, and printed out by the Flexowriter along with the elapsed time data as recorded by the DRR. The

operation of the system can best be described by breaking it down into two modes of operation, the record mode and the playback mode. Each mode will be discussed below.

RECORD MODE OPERATION

When a photographic station is triggered, a voltage pulse is generated which performs two functions. First, it is fed through a mixer circuit and is used as the data pulse which "reads" the counters in the DRR. Secondly, it triggers a thyratron in the station fired indicator circuits (see fig. 1). The pulse derived from the thyratron is fed to a "binary coded decimal" (BCD) code converter which converts the assigned station number into a binary form which then can be handled by the system. The information in binary form is fed to the six record amplifier channels and is stored until an interrogation pulse is generated in the DRR. The generated interrogation pulse is used to read the information that is stored in the station coding record channels. The resulting information is then fed to the record heads and recorded on the magnetic drum along with the counter readings and the appropriate control signals.

Figure 2 shows the circuit diagram of the BCD code converter using a standard diode matrix converter system (see ref. (c)). Pulses will appear on certain output lines or lines depending upon which input is energized. The first four output lines comprise the digit in the "units" position of the two digit decimal number. The remaining two output lines comprise the digit in the "tens" position of the two digit decimal number. With the six channels available, 39 decimal numbers can be coded in the BCD system.

Figure 3 shows a block diagram of a typical station identification system with representative waveforms showing the time relationship of the pulses in the channel. The waveform represented at B of Figure 3 is the amplified and shaped input pulse that drives unit 4 which is a 20-microsecond one-shot multivibrator. As a result of the one-shot action, a pulse is effectively stored in the channel for a period of 20 microseconds. This stored information is applied to the "And" gate, unit 5, as one of two inputs. The second input to the "And" gate is the interrogation pulse generated by the DRR and is represented at D. This pulse is delayed approximately 7 microseconds before the station fires, which is the reason for the need of temporary storage. This delay is necessary because of the method of sampling the counters in the DRR. Thus, if there is a pulse at C at

the time an interrogation pulse arrives at D, the "And" gate will produce an output at E and a pulse is recorded on the magnetic drum which corresponds to a "1" recording. If there is no pulse at C, which corresponds to a "0" in the channel at the time an interrogation pulse arrives, there will be no pulse at E, and thus no pulse will be recorded which corresponds to a "0" recording.

Unit 1 is a transistorized amplifier and blocking oscillator circuit, see figure 4, that standardizes the input pulses for driving the pulse amplifier. The unit is built up into a single plug-in type module to facilitate the maintenance of the equipment. Units 2 through 7 are commercial type plug-in modules. Units 4 and 6 are basically one-megacycle flip-flops that have been modified as shown in figure 5 to operate as high-speed one-shot multivibrators. Unit 4 provides the temporary storage that is necessary and unit 6 provides the required pulse duration and amplitude for supplying the record head for recording on the magnetic drum.

PLAYBACK MODE OPERATION

In the playback mode of operation, the information that is recorded on the magnetic drum is amplified through the station coding playback amplifier channels at the same time as the data signals are played back through the data playback amplifier channels in the DRR (see fig. 6). When the desired reading number has been reached as dictated by the DRR, the resulting "read" pulse reads the data channels and also reads the station coding playback channels. The resulting read information is then stored into a thyratron-relay storage system until the Flexowriter completes the printout of the stored information. The relay contact arrangement converts the binary coded decimal number into a decimal number which is indicated on indicator tubes which provides the visual readout. The relay arrangement also converts the binary coded decimal number to the inverse BCD code required for Flexowriter operation. The Flexowriter then prints out the station number in decimal form along with the desired reading number of the elapsed time data that was obtained from that particular station. A typical shot data sheet is shown in figure 7.

Figure 8 shows a block diagram of a typical playback channel. All units are commercial plug-in type modules. Units 1 through 4 are amplifier units that produce as one of two inputs to unit 5 (an "And" gate), a positive pulse of 45 to 50 volts in amplitude, provided a "1" was recorded in that particular

channel. The second pulse applied to unit 5 is the "read" pulse from the DRR. Thus, for a particular "read" pulse, if a "1" was recorded in the channel an output would result. If a "0" (no pulse) was recorded in that particular channel no output would result. Unit 6 is an amplifier unit with external circuitry added to operate as a modified one-shot multivibrator. The output pulse is a positive pulse of approximately 2 milliseconds duration and is used to fire the thyatron in the thyatron-relay storage circuits shown in figure 9.

The thyatron-relay storage system uses standard thyatron circuitry with a plate circuit relay associated with each thyatron. The plate circuit relay contact arrangement is a basic two and a basic four transfer-tree arrangement with an additional set of contact for supplying Flexowriter information. The "A" levels of each relay provide the proper coding inputs to the Flexowriter for printed readout, and the remaining levels provide the proper routing of the ground connections to the indicator tubes for visual readout. Reset of the thyatrons, and thus the relays, is accomplished by disconnecting the plate voltage from the plate circuits of the thyatrons. The plate voltage is disconnected by an external relay contact opening when "end of reading" has been reached by the DRR. After sufficient time has allowed the Flexowriter carriage to return and all the circuitry to reset to the reset condition, then the equipment is ready to accept the next desired reading number that has been recorded by the DRR.

COMMENTS

The station identification system has been installed and checked out and is now in operation with the DRR. A few noise and pickup problems were encountered when first installed; however, these problems have been satisfactorily solved and at present the system is giving reliable operation.

Three facilities, the Aerodynamics Range No. 1, the Pressurized Ballistics Range No. 3, and the 1,000-ft. Hyperballistics Range No. 4 are presently incorporated with the station identification system. Other facilities contemplating the use of the DRR as the chronograph system and that require identification of the data pulses can also be incorporated with the system.

The completed system being integrated with the DRR will give much more data per shot than any previous system and will

also greatly reduce the amount of time previously required for the data reduction. The station identification system also lends itself to any automatic data reduction system that may be contemplated for use in the future.

References

- (a) R. C. Folz and J. W. Roberts, "The Data Recorder-Reproducer -- A Time Interval Measuring Instrument For Use In The Ballistics Facilities Of The Naval Ordnance Laboratory," NavWeps report 7307
- (b) "Aeroballistics Research Facilities," NOLR 1233
- (c) Caldwell, Samuel H., "Switching Circuits And Logical Design," John Wiley & Sons Inc. 1958

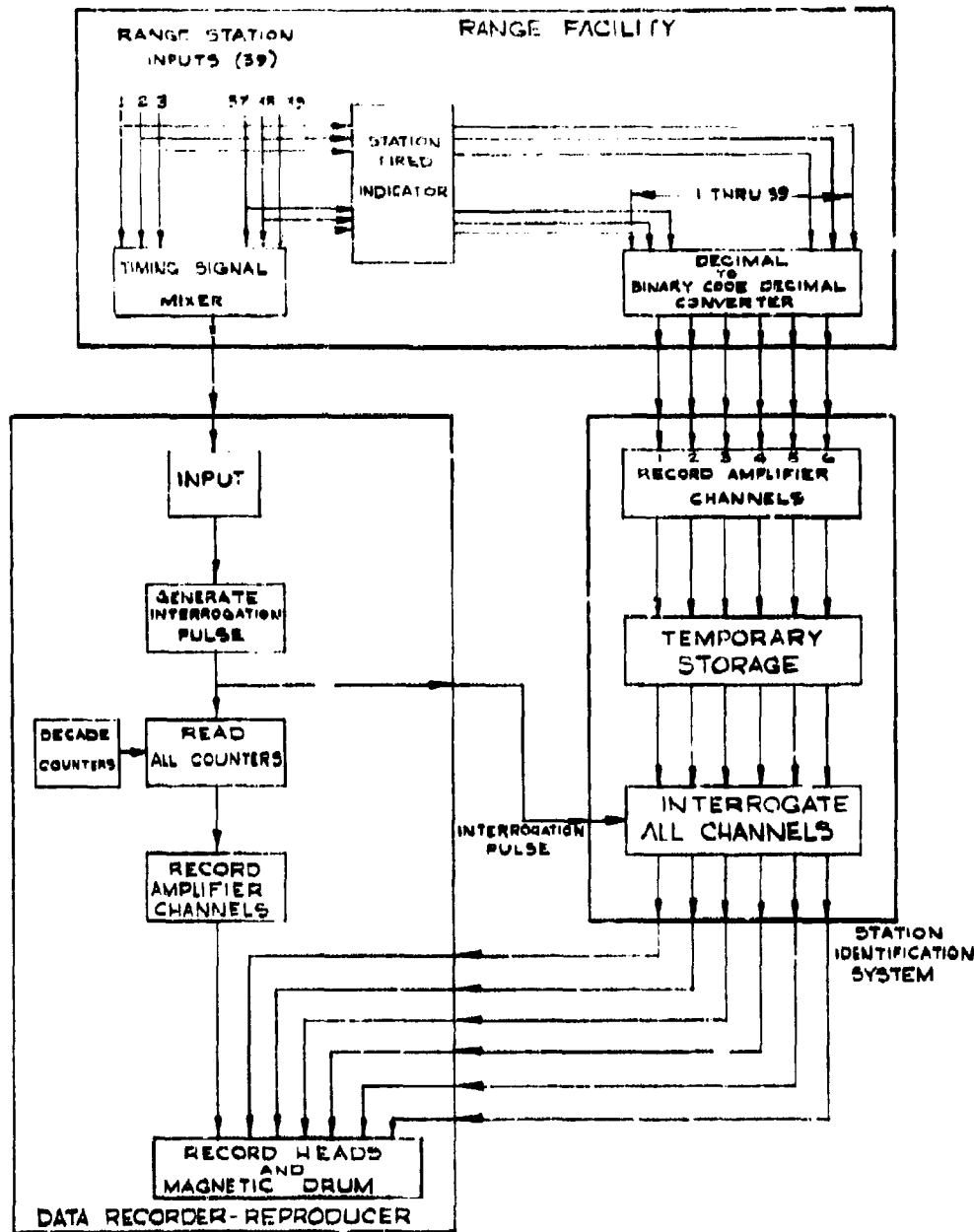

FIG.1 SIMPLIFIED RECORD FLOW DIAGRAM

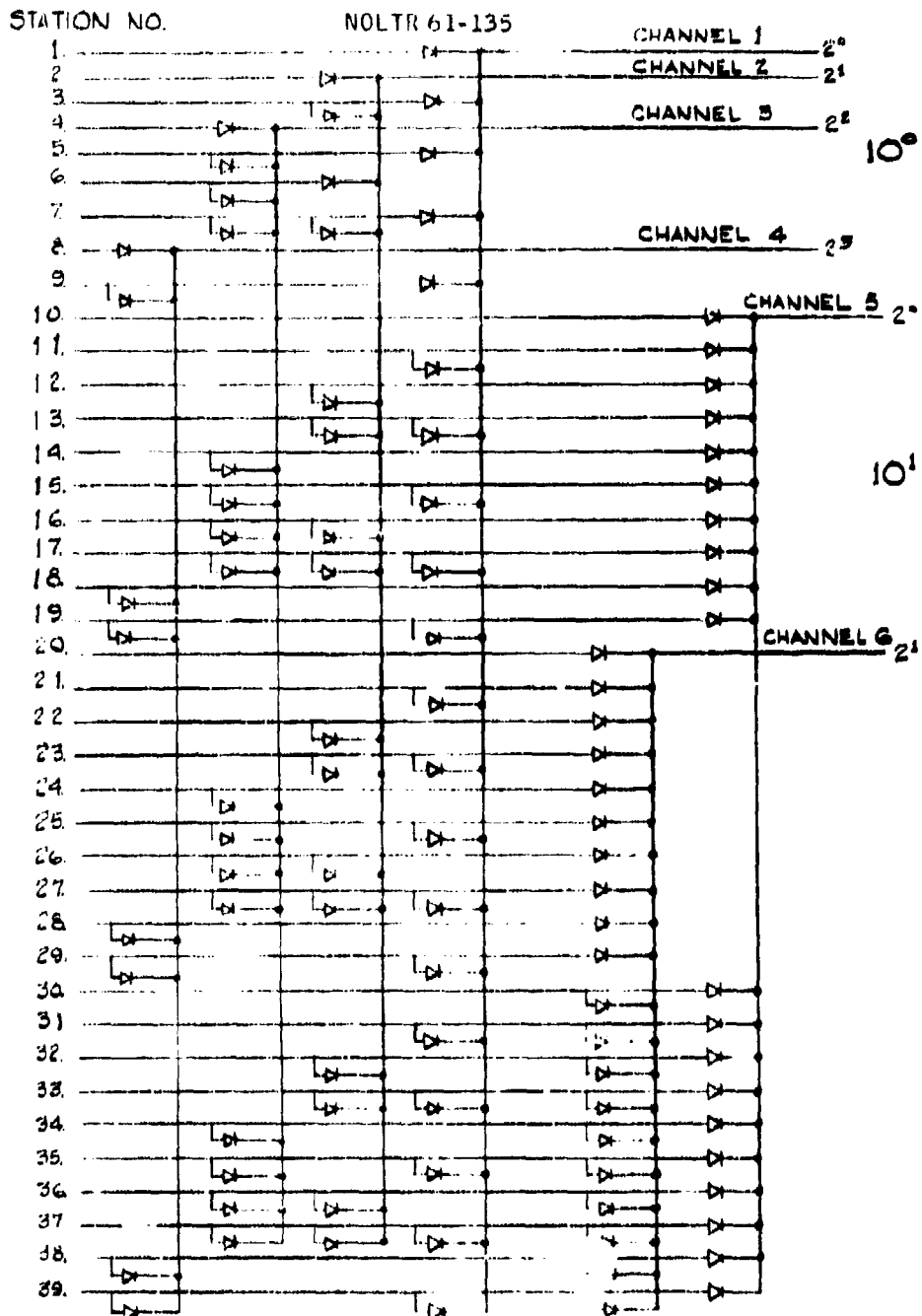

FIG.2 DIODE MATRIX FOR CONVERTING TO BCD FROM DECIMAL(139)

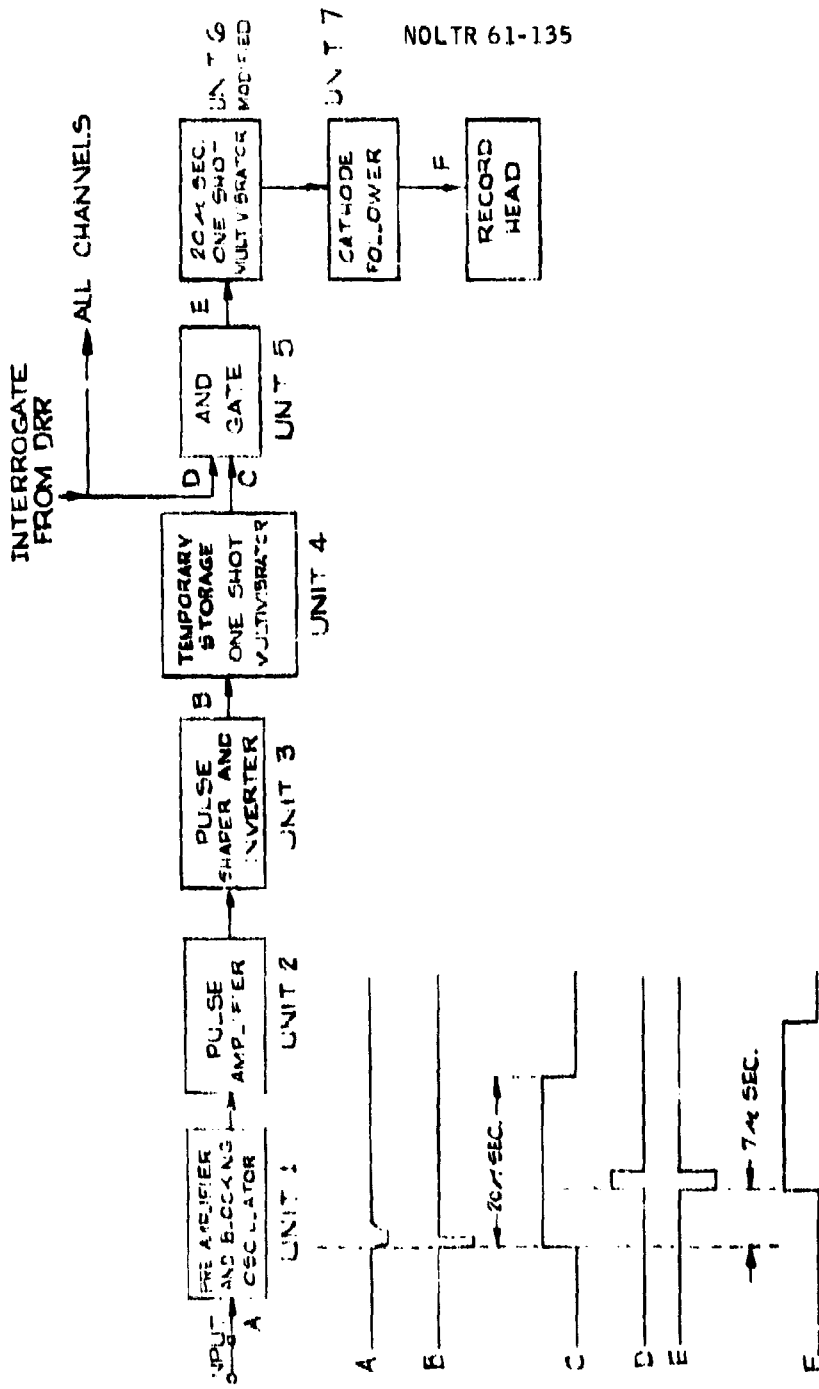

FIG. 3 TYPICAL RECORD CHANNEL BLOCK DIAGRAM WITH REPRESENTATIVE WAVEFORMS

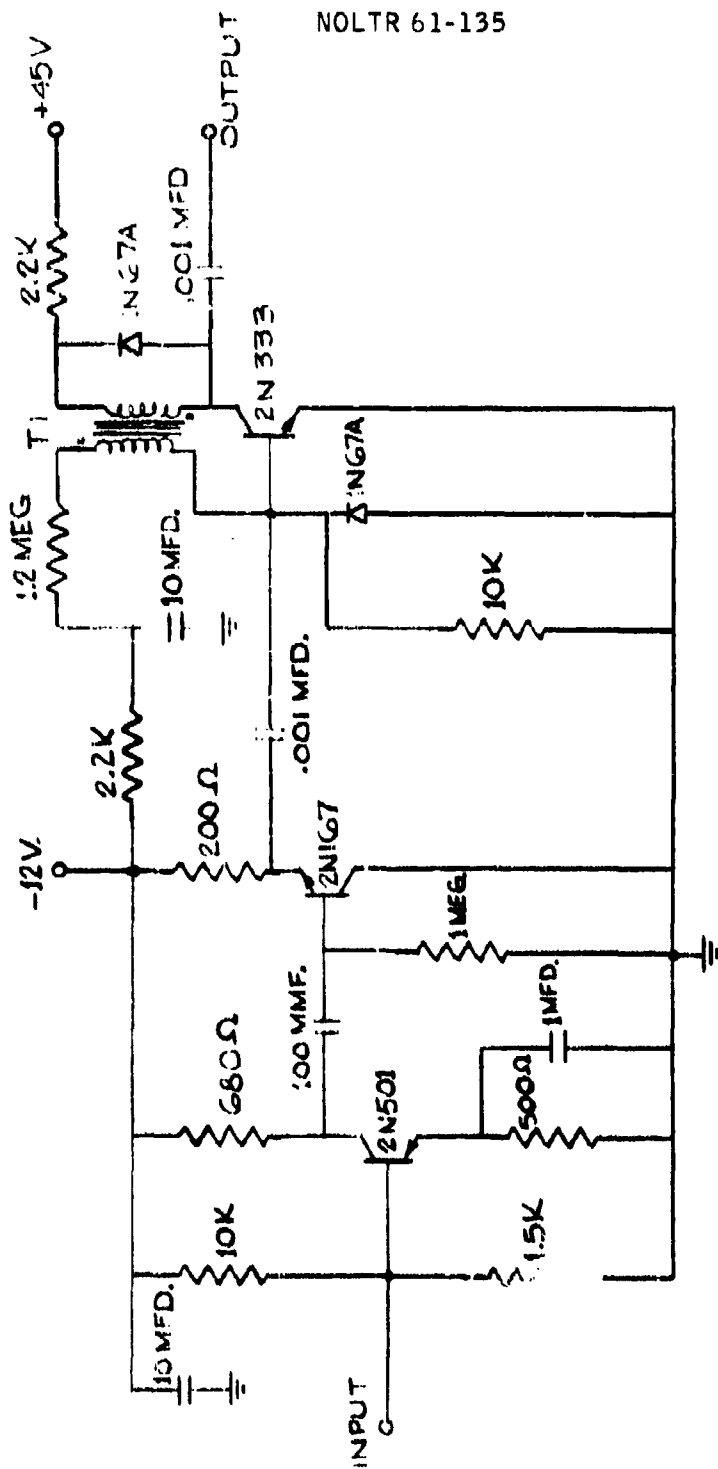
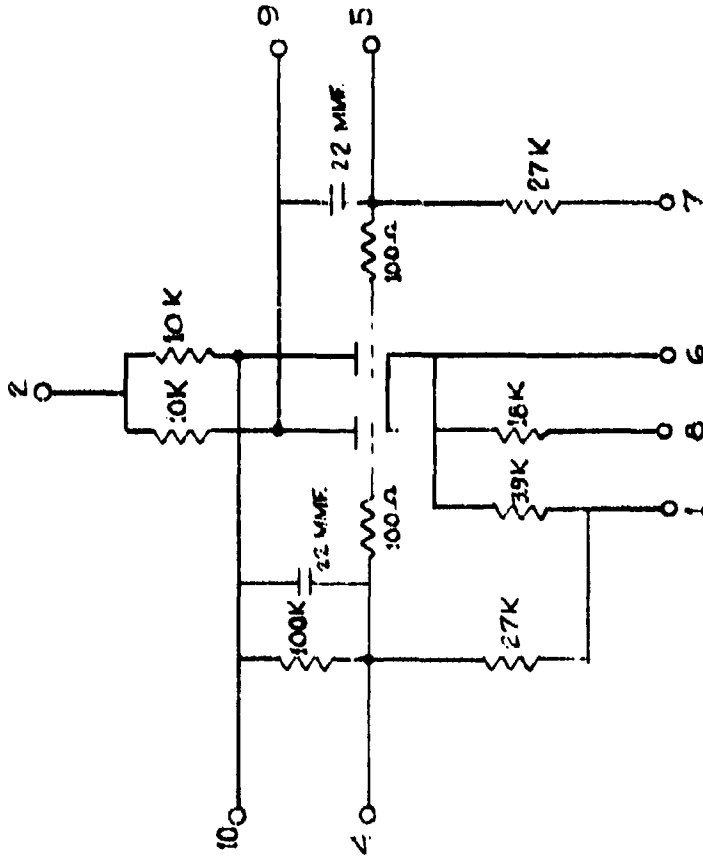

FIG. 4 SCHEMATIC DIAGRAM OF RECORD, PREAMPLIFIER AND BLOCKING OSCILLATOR



TUBE TYPE:59G4

FIG.5 ONE SHOT MULTIVIBRATOR SCHEMATIC

FIG.5 ONE SHOT MULTIVIBRATOR SCHEMATIC

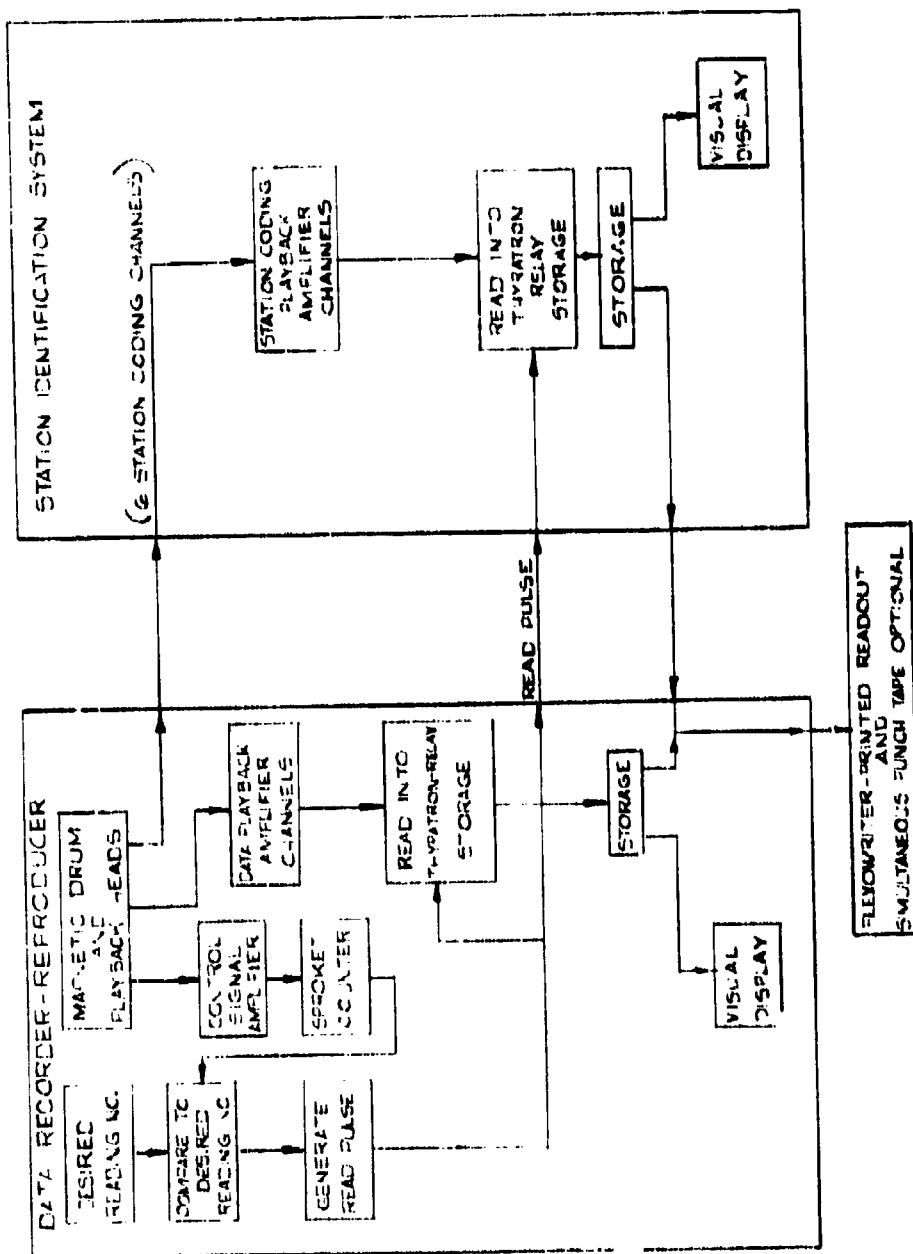

FIG.6 SIMPLIFIED PLAYBACK FLOW DIAGRAM

NOLTR 61-135

RANGE PBR SHOT NO. 4194 DATE 1-6-61 TIME 1035
 READING MULTIPLIER (MICROSECONDS) 0.1

000	+022120	02
001	+030231	03
002	+035173	04
003	+043528	05
004	+048703	06
005	+056892	07
006	+061992	08
007	+070315	09
008	+075440	10
009	+083812	11
010	+088986	12
011	+097235	13
012	+102477	14
013	+110976	15
014	+116066	16
015	+124417	17
016	+138021	19
017	+143412	20
018	+169307	21
019	+195466	22
020	+221791	23
021	+248236	24
<u>022</u>	<u>+274662</u>	<u>25</u>

Station Number
 Elapsed Time Data
 Reading Number

FIG.7 TYPICAL SHOT DATA SHEET

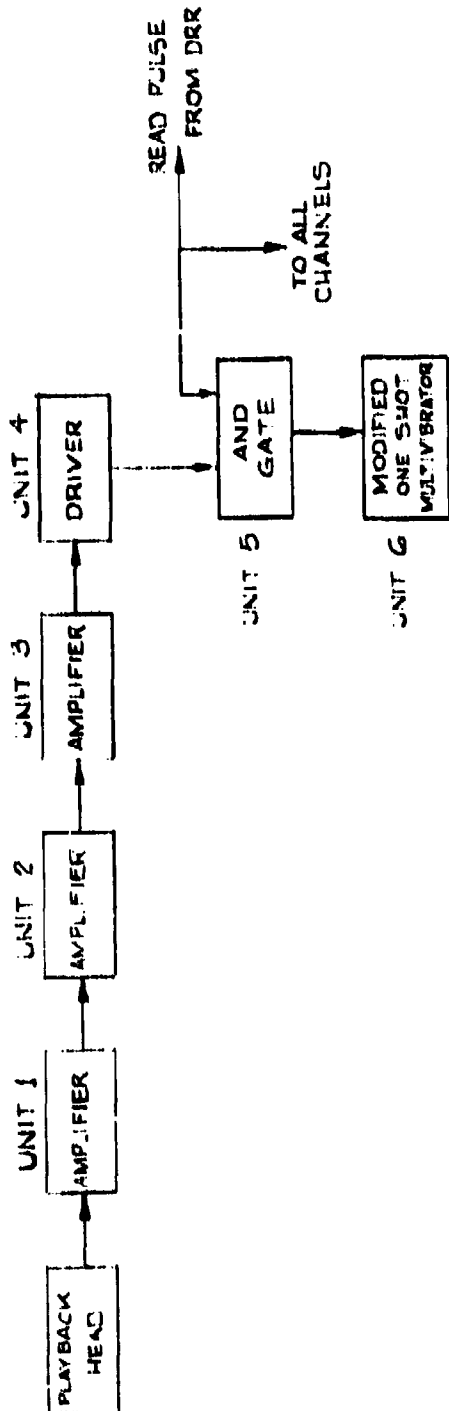

FIG.8 TYPICAL PLAYBACK CHANNEL BLOCK DIAGRAM

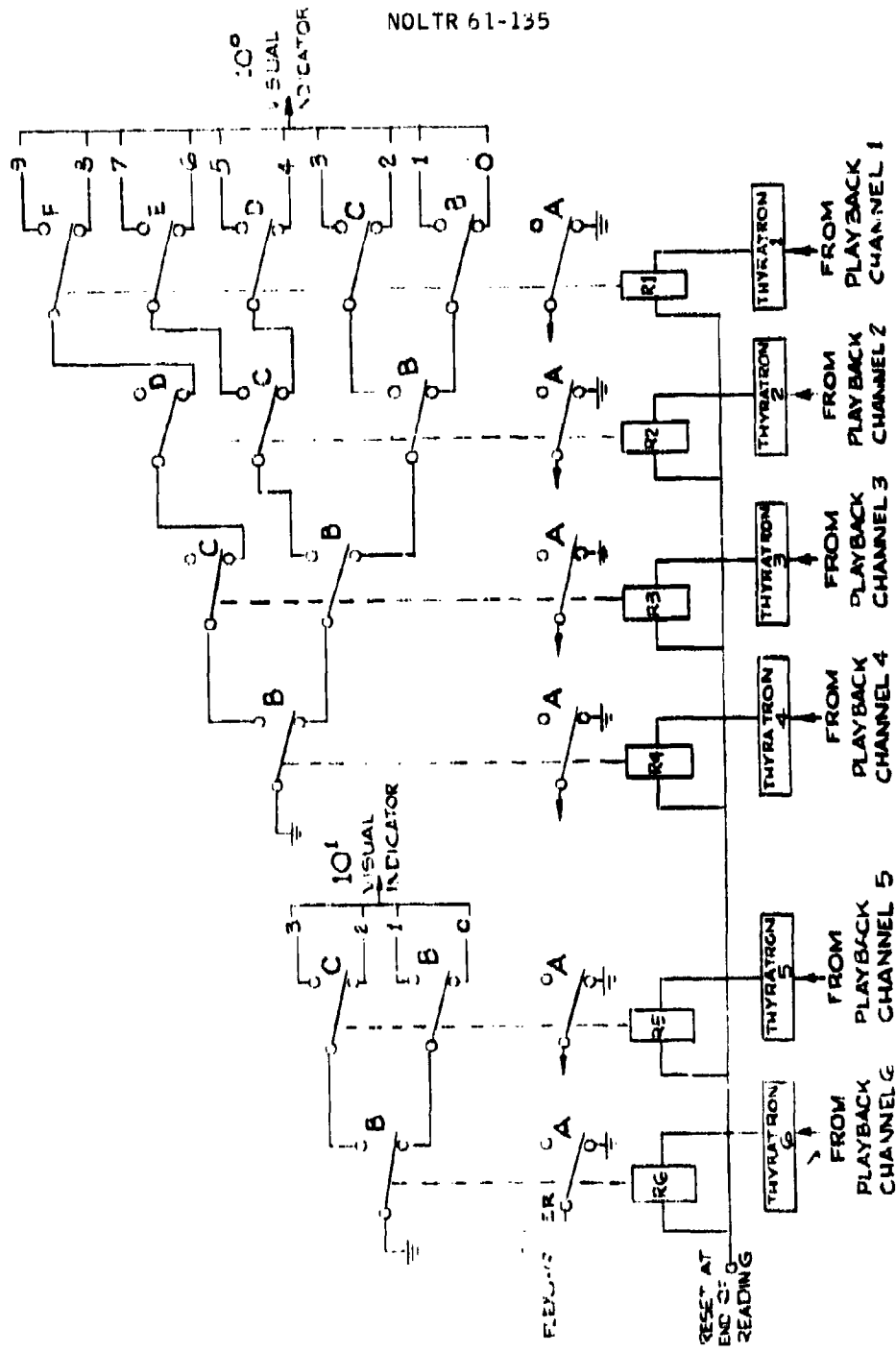

FIG. 9 THYATRONS-RELAY STORAGE AND CODE CONVERTER

External Distribution List

	<u>No. of Copies</u>
Chief, Bureau of Naval Weapons Department of the Navy Washington 25, D. C.	
Attn: RMMO	1
Attn: RMGA	1
Attn: RRMA	1
Director, Special Projects Department of the Navy Washington 25, D. C.	
Attn: SP-20	4
Attn: SP-27	2
Attn: SP-272	1
Office of Naval Research Room 2709 - T-3 Washington 25, D. C.	
Attn: Head, Mechanics Br.	1
Commanding Officer Office of Naval Research Branch Office, Box 39, Navy 100 Fleet Post Office, New York, N. Y.	5
Director, DTMB Aerodynamics Laboratory Washington 7, D. C.	
Attn: Library	1
Naval Weapons Laboratory Dahlgren, Va.	
Attn: Library	1
Commander U. S. Naval Ordnance Test Station China Lake, Calif.	
Attn: Technical Library	1
Director Naval Research Laboratory Washington 25, D. C.	
Attn: Code 2027	1
Attn: Mr. Edward Chapin, Room 6310	1

No. of Copies

NASA	
Langley Research Center	
Langley Field, Va.	
Attn: Librarian	1
Attn: C. H. McLellan	1
Attn: J. J. Stack	1
Attn: Adolf Busemann	1
Attn: Rodger W. Peters (Structures Res. Div.)	1
Attn: Russell Hopko, PARC	1
NASA	
Ames Research Center	
Moffett Field, Calif.	
Attn: Librarian	1
NASA	
Lewis Research Center	
21000 Brookpark Rd.	
Cleveland, Ohio	
Attn: Chief, Propulsion Aerodynamics Div.	1
Attn: Mr. George Mandel, Chief, Library	2
Office of the Assistant	
Secretary of Defense (R&D)	
Room 3E1041, The Pentagon	
Washington 25, D. C.	
Attn: Library (Technical)	1
Research and Development Board	
Room 3D1041, The Pentagon	
Washington 25, D. C.	
Attn: Library	2
ASTIA	
Arlington Hall Station	
Arlington 12, Va.	
Attn: TIPDR	10
Commander, NMC	
Point Mugu, Calif.	
Attn: Technical Library	1
Commanding General	
Aberdeen Proving Ground, Md.	
Attn: Technical Info. Br.	1
Attn: Ballistics Research Laboratories	1

No. of Copies

Director of Intelligence Headquarters, USAF Washington 25, D. C. Attn: AFOIN-3B	1
Commander Wright Air Development Div. Wright-Patterson Air Force Base, Ohio Attn: WCOSI-3 Attn: WCLSW-3 Attn: WCRRD	2 1 3
Commander, AFBMD Air Res. & Develop. Command P. O. Box 262 Inglewood, Calif. Attn: WDTLAR Attn: WDTVR	1 2
Chief, DASA The Pentagon Washington, D. C. Attn: Document Library	1
Commanding General Arnold Engineering Development Center Tullahoma, Tenn. Attn: Technical Library Attn: AEKS	1 3
Commanding Officer, DOFL Washington 25, D. C. Attn: Library Rm. 211, Bldg. 92	1
NASA George C. Marshall Space Flight Center Huntsville, Alabama Attn: M-S&M-PT (Mr. H. A. Connell) Attn: Dr. W. R. Lucas (M-SFM-M) Attn: Dr. Ernst Geissler	5 1 1
Office Chief of Ordnance Department of the Army Washington 25, D. C. Attn: ORDTU	1

No. of Copies

APL/JHU 8621 Georgia Ave. Silver Spring, Md.	
Attn: Tech. Reports Group	2
Attn: Dr. D. Fox	1
Attn: Dr. Freeman Hill	1
Attn: Dr. L. L. Cronvich	1
Attn: Librarian	1
AVCO Manufacturing Corp. Research & Advanced Development Div. 201 Lowell Street Wilmington, Mass.	
Attn: Mr. J. P. Wanser	1
AVCO Manufacturing Corp. Everett, Mass.	
Attn: Dr. Kantrowitz	1
General Electric Co. Space Vehicle & Missiles Dept. 21 South 12th St. Philadelphia, Penn.	
Attn: Dr. J. Stewart	1
Attn: Dr. Otto Klima	1
Attn: Mr. E. J. Nolan	1
Attn: Jr. L. McCreight	1
General Electric, Research Lab. 319B Chestnut St. Philadelphia, Penn.	
Attn: Dr. Leo Steg	1
National Aeronautics and Space Admin. 1520 H Street, N. W. Washington, D. C.	
	5
NASA High Speed Flight Station Edwards Field, Calif.	
Attn: W. C. Williams	1
Aerospace Corporation El Segundo, Calif.	
Attn: Dr. Bitondo	1

No. of Copies

Lockheed Aircraft Corp. Missiles and Space Div. P. O. Box 504 Sunnyvale, Calif. Attn: Dr. L. H. Wilson	1
Lockheed Aircraft Corp. Research Lab. Palo Alto, Calif. Attn: W. Griffith	1
Atomic Energy Commission Engineering Development Branch Division of Reactor Development Headquarters, US AEC Washington 25, D. C. Attn: Mr. J. M. Simmons Attn: Mr. M. J. Whitman Attn: Mr. J. Conners	1 1 1
University of California Lawrence Radiation Laboratory P. O. Box 808 Livermore, Calif. Attn: Mr. W. M. Wells, Propulsion Div. Attn: Mr. Carl Kline	1 1
Oak Ridge National Laboratory P. O. Box E Oak Ridge, Tenn. Attn: Mr. W. D. Manly	1
Polytechnic Institute of Brooklyn 527 Atlantic Avenue Freeport, N. Y. Attn: Dr. Paul A. Libby	1
General Applied Sciences Laboratories, Inc. Merrick and Stewart Avenues East Meadow, New York Attn: Mr. Robert Byrne	1
Jet Propulsion Laboratory 4800 Oak Grove Drive Pasadena 3, Calif. Attn: I. R. Kowlan, Chemicals Support Group Attn: Dr. L. Jaffee	1 2

No. of Copies

Los Alamos Scientific Laboratory P. O. Box 1663 Los Alamos, New Mexico Attn: Dr. Donald F. MacMillan N-1 Group Leader	1
Institute for Defense Analyses Advanced Research Projects Agency Washington 25, D. C. Attn: Mr. W. G. May General Sciences Branch	1
Kaman Aircraft Corporation Nuclear Division Colorado Springs, Colorado Attn: Dr. A. P. Bridges	1
U. S. Atomic Energy Commission P. O. Box 62 Oak Ridge, Tennessee Attn: TRI:NLP:ATD:10-7	1
Sandia Corporation Livermore Laboratory P. O. Box 969 Livermore, Calif.	1
United Aircraft Corporation Research Laboratories East Hartford 8, Conn. Attn: Mr. H. J. Charette Attn: Mr. H. Taylor	1 1
Sandia Corporation Sandia Base Albuquerque, New Mexico Attn: Mr. Alan Pope	1
Defense Metals Information Center Battelle Memorial Institute 505 King Avenue Columbus 1, Ohio	1
Commanding General Army Rocket and Guided Missile Agency Redstone Arsenal, Alabama Attn: John Morrow	1

NOLTR 81-135

No. of Copies

National Bureau of Standards
Washington 25, D. C.
Attn: Dr. Galen B. Schubauer

1

Cornell Aeronautical Laboratory
4455 Genesee Street
Buffalo, New York
Attn: Dr. Gordon Hall

1

Naval Ordnance Laboratory, White Oak, Md.

(NR technical report 6-135)

A BALLISTICS RANGE STATION IDENTIFICATION SYSTEM TO BE USED IN CONNECTION WITH A DATA RECORDER-REPRODUCER by R.C. Fols, 6 Oct. 1967. 6p. tables, diagrams. (Ballistics research report 56). UNCLASSIFIED

A ballistics range station identification system has been designed and constructed that provides a unique correlation of a series of elapsed time measurements as recorded by a data recorder-reproducer, with their respective sources. The final data readout is presented in a visual manner and is also automatically printed out by a Flexwriter. The identifying information is presented with the elapsed time data for each measurement that was recorded.

Ballistic ranges -

1. Instruments
2. Reproducers
3. Data recorder
4. Flexwriter
- I. Title
- II. Fols, Robert C.
- III. Series

Naval Ordnance Laboratory, White Oak, Md.

(NR technical report 6-135)

A BALLISTICS RANGE STATION IDENTIFICATION SYSTEM TO BE USED IN CONNECTION WITH A DATA RECORDER-REPRODUCER by R.C. Fols, 6 Oct. 1967. 6p. tables, diagrams. (Ballistics research report 56). UNCLASSIFIED

A ballistics range station identification system has been designed and constructed that provides a unique correlation of a series of elapsed time measurements as recorded by a data recorder-reproducer, with their respective sources. The final data readout is presented in a visual manner and is also automatically printed out by a Flexwriter. The identifying information is presented with the elapsed time data for each measurement that was recorded.

Ballistic ranges -

1. Instruments
2. Reproducers
3. Data recorder
4. Flexwriter
- I. Title
- II. Fols, Robert C.
- III. Series

Naval Ordnance Laboratory, White Oak, Md.

(NR technical report 6-135)

A BALLISTICS RANGE STATION IDENTIFICATION SYSTEM TO BE USED IN CONNECTION WITH A DATA RECORDER-REPRODUCER by R.C. Fols, 6 Oct. 1967. 6p. tables, diagrams. (Ballistics research report 56). UNCLASSIFIED

A ballistics range station identification system has been designed and constructed that provides a unique correlation of a series of elapsed time measurements as recorded by a data recorder-reproducer, with their respective sources. The final data readout is presented in a visual manner and is also automatically printed out by a Flexwriter. The identifying information is presented with the elapsed time data for each measurement that was recorded.

Ballistic ranges -

1. Instruments
2. Reproducers
3. Data recorder
4. Flexwriter
- I. Title
- II. Fols, Robert C.
- III. Series

Naval Ordnance Laboratory, White Oak, Md.

(NR technical report 6-135)

A BALLISTICS RANGE STATION IDENTIFICATION SYSTEM TO BE USED IN CONNECTION WITH A DATA RECORDER-REPRODUCER by R.C. Fols, 6 Oct. 1967. 6p. tables, diagrams. (Ballistics research report 56). UNCLASSIFIED

A ballistics range station identification system has been designed and constructed that provides a unique correlation of a series of elapsed time measurements as recorded by a data recorder-reproducer, with their respective sources. The final data readout is presented in a visual manner and is also automatically printed out by a Flexwriter. The identifying information is presented with the elapsed time data for each measurement that was recorded.

Ballistic ranges -

1. Instruments
2. Reproducers
3. Data recorder
4. Flexwriter
- I. Title
- II. Fols, Robert C.
- III. Series

Ballistic ranges -

1. Instruments
2. Reproducers
3. Data recorder
4. Flexwriter
- I. Title
- II. Fols, Robert C.
- III. Series

Ballistic ranges -

1. Instruments
2. Reproducers
3. Data recorder
4. Flexwriter
- I. Title
- II. Fols, Robert C.
- III. Series