

UNCLASSIFIED

AD 276 712

*Reproduced
by the*

**ARMED SERVICES TECHNICAL INFORMATION AGENCY
ARLINGTON HALL STATION
ARLINGTON 12, VIRGINIA**



UNCLASSIFIED

NOTICE: When government or other drawings, specifications or other data are used for any purpose other than in connection with a definitely related government procurement operation, the U. S. Government thereby incurs no responsibility, nor any obligation whatsoever; and the fact that the Government may have formulated, furnished, or in any way supplied the said drawings, specifications, or other data is not to be regarded by implication or otherwise as in any manner licensing the holder or any other person or corporation, or conveying any rights or permission to manufacture, use or sell any patented invention that may in any way be related thereto.

DISCLAIMER NOTICE

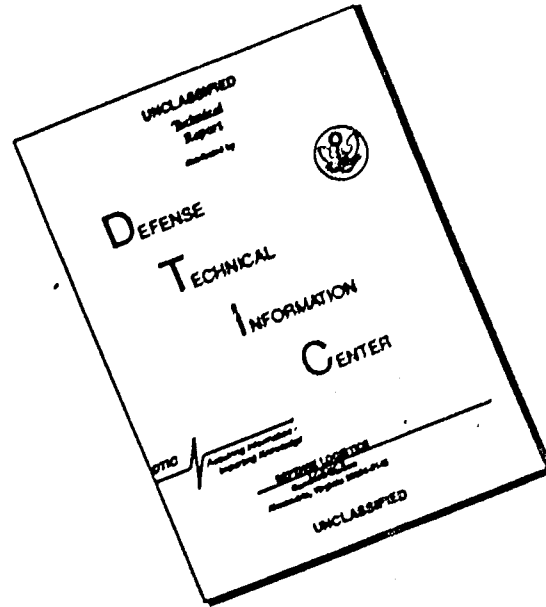

THIS DOCUMENT IS BEST QUALITY AVAILABLE. THE COPY FURNISHED TO DTIC CONTAINED A SIGNIFICANT NUMBER OF PAGES WHICH DO NOT REPRODUCE LEGIBLY.

276 712

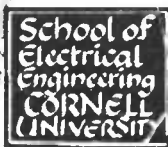

CORNELL UNIVERSITY

SCHOOL OF ELECTRICAL ENGINEERING

RESEARCH REPORT EE 522

**Graph Theoretical Aspects of Admittance
and Impedance Matrices**

30 November 1961

J. D. Douglass, Jr.

ELECTRONICS RESEARCH, Technical Report No. 69

[Contract No. DA36-039-sc 85272]

School of Electrical Engineering
CORNELL UNIVERSITY
Ithaca, New York

RESEARCH REPORT EE 522

GRAPH THEORETICAL ASPECTS
OF ADMITTANCE AND IMPEDANCE MATRICES

J. D. Douglass, Jr.

ELECTRONICS RESEARCH

Technical Report No. 69

30 November 1961

Published under U. S. Signal Corps Contract No. DA36-039-sc-85272
U. S. Army Signal Research and Development Laboratory, Fort Monmouth, N. J.

ACKNOWLEDGMENTS

The author wishes to express his gratitude to the following individuals for their assistance during the course of this investigation: Professor N. DeClaris for his constant guidance and advice, Professor H. S. McGaughan for his many helpful discussions, and Professor R. P. Agnew for his advice on a course of study. The author is also indebted to The General Dynamics Corporation for sponsoring the fellowship.

CONTENTS

	Page
ABSTRACT	v i
I. INTRODUCTION	1
II. SHORT-CIRCUIT ADMITTANCE MATRIX	7
2.1 Analysis	7
2.2 Direct Synthesis of a Completely Specified Y^{SC} Matrix	21
2.3 Realization of Y^{SC} with Zero Entries	29
2.4 Specification of Zero Entries	50
III. THE OPEN-CIRCUIT IMPEDANCE MATRIX	53
3.1 Analysis	53
3.2 Realization of Z^{OC}	69
3.21 Phase 1	71
3.22 Phase 2	77
3.23 Phase 3	79
3.24 Phase 4	81
3.3 Specification of Arbitrary Entries	89
3.4 Remarks	90
IV. MULTIPORTS AND RELATED TOPICS	91
4.1 Relations between Y^{SC} , Z^{OC} , and Multiports	91
4.2 Reduced Networks	96
4.3 Network Analysis Involving Multiports	101
APPENDIX A. EXPLANATION OF TERMS	108
APPENDIX B. MAXIMUM NUMBER OF BRANCHES IN PLANAR GRAPH	110
BIBLIOGRAPHY	115

ABSTRACT

This report is concerned with the realization of RLC admittance and impedance matrices. It establishes necessary and sufficient conditions, in terms of direct synthesis procedures, for the realizability of n^{th} order Y or Z matrices. Each independent branch of the resulting structure is a two-terminal driving-point impedance in series with a voltage source, or a two-terminal driving-point admittance in parallel with a current source. Each dependent branch is a two-terminal driving-point admittance or impedance.

Both the admittance and impedance realization procedures are completely general. They are developed from, and follow, a re-evaluation of cut-set and tie-set methods of obtaining the admittance and impedance matrices. These methods are not mentioned by their common names, but instead are identified by the name "region" and "circuit." This is done merely to place emphasis on the important physical interpretation of the mathematical processes of analysis. This same interpretation is also considered to lead to a clearer understanding of the realization process. In the analysis this interpretation also shows how the matrix may be written by inspection without having to consider cut-set and tie-set matrices.

The realizations of the Y and the Z matrices are developed independently. It is shown in the formulation of the Y matrix that each and every entry has an associated plus or minus sign -- even zero entries. The signs of the entries conclusively determine the geometry of the independent branch voltages, that is, the tree, and by so doing set forth all possible ways in which dependent branches may be connected. The "magnitudes"

of the entries determine the actual dependent branches themselves. This characteristic of the Y matrix is dramatically opposed to the Z matrix. First, half of the Z matrix zero entries have no sign associated with them. Second, if all the signs are known, the geometry of the independent current branches is still questionable. One predominant cause of these differences is connectedness: The independent voltage branches are connected, while this restriction is not placed on the independent current branches; hence the signs of the Z matrix determine only a set of possible independent branch geometries, while the Z magnitudes determine which set is required. A reduction process applied to the Z matrix then develops the dependent branches one by one.

Following the development of these realization procedures, and selected examples from them, the matrices under consideration and the inverse matrices are discussed in detail. In this discussion, the differences between a tie-set Z matrix and the inverse of a cut-set Y matrix are pointed out as well as the differences between a cut-set Y matrix and the inverse of a tie-set Z matrix. At the same time the change in network geometry that results from interpreting a cut-set Y matrix as a multiport matrix, and a tie-set Z matrix as a multiport matrix, is illustrated. The process of reducing the number of response variables from the cut- or tie-set Y or Z matrices is then described, along with its physical interpretation. This leads into the analysis of networks containing multi-terminal elements, which forms the concluding topic in this study.

I. INTRODUCTION

A basic discipline in modern network science revolves about the interpretation and utilization of the geometric properties of a network. These properties involve both the structure of the network and the placement of elements within the network structure. The emergence of this discipline was accompanied by a variety of descriptive titles that have recently been narrowed down to the theory of linear graphs. The present theory of linear graphs finds a wide variety of applications in network analysis and realization. In general the material encompasses a wide variety of approaches and is presented in many levels of difficulty. For an excellent survey of such literature as it applies to electrical network theory, the reader is referred to S. Seshu and M. B. Reed.¹ To be able to approach the subject matter of this study, the reader should be familiar with the terms "branch," "node," "graph," "tree," "co-tree," "chord" or "link," "cut set," "tie set," and "oriented graph." Brief definitions of these terms are given in Appendix A, and more explicit descriptions may be found in Seshu and Reed.¹

The principal object of this thesis is to present new methods of analysis and synthesis for linear bilateral networks based on topological notions. First, several of the above concepts are discussed from the admittance and impedance viewpoint. Following this discussion, the analysis and synthesis of n^{th} order admittance and impedance matrices corresponding to networks having n independent branches is presented. The discussion concludes with the analysis of networks with incorporated multiterminal elements.

The two basic elements in the network topology are the node and the branch. In this study, a network branch, or simply a branch, is shown in its most general form in Figure 1. Note that a voltage source

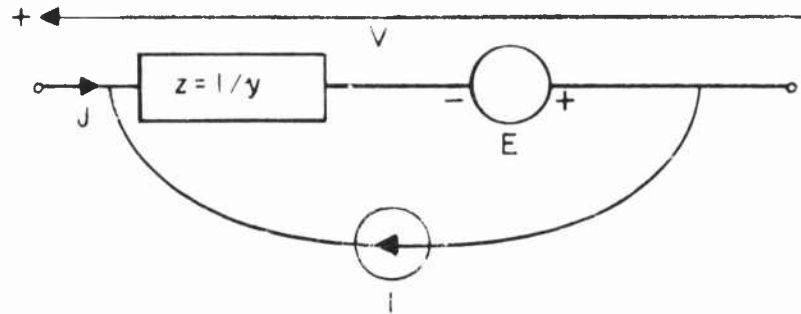

Figure 1. Generalized Branch. (Response variables: J = branch current, V = branch voltage; Excitation variables: I = branch source current, E = branch source voltage.)

in parallel with an impedance must be considered as two branches in parallel, and that a current source in series with an impedance must be considered as two branches in series. The branch as shown may, in essence, be considered as a network itself, if one considers every physical element as a branch. In this discussion, however, the branch plays the role of a distinguishable two-terminal device. In line with this, the nodes are considered as the accessible terminals of a branch. The reasoning behind this distinction will become clear in the realization* procedures of the following chapters.

* Realization has come to be colloquially synonymous with synthesis, although synthesis includes both problems of approximation and realization.

When a collection of branches and nodes are brought together, the resultant structure is called a graph. In analyzing the response of a network to its exciting sources, the branches of the network graph are divided, according to Kirchhoff's laws, into two sets: a set of dependent branches and a set of independent branches. To be more precise, if the response is desired in terms of branch voltages, a set of independent voltage branches, which comprise a tree* of the network graph, are selected and the complementary set of branches is termed dependent. This complementary set is dependent, however, only in so far as voltage analysis is concerned, since it exactly comprises a set of independent branches that form a co-tree,* if the response is desired in terms of branch currents. Here, it is interesting to note that if the graph G is separated into two subgraphs G_1 and G_2 , the separation can always be done such that G_1 is planar,² but not in a manner such that both G_1 and G_2 are planar. This follows from the fact that the maximum number of nonparallel branches in a planar network containing n nodes is $3n - 6$ (see Appendix B). Since the independent voltage branches form a tree, and thus a planar subgraph, nothing can be said for the general case regarding the planarity of the subgraph of independent current branches.

In the analysis and realization problem, it is immediately apparent that a direction or orientation must be assigned to the independent branches, and such orientation will affect the signs in the pertinent Y or Z matrix. In Chapters II and III this is illustrated and emphasized, and is recognized after a re-evaluation of cut-set² and tie-set² methods of obtaining the

* See Appendix A for definition.

short-circuit admittance and open-circuit impedance matrices. These methods are not referred to by their common names, but instead are identified by the names "region" and "circuit." This is not intended as a change in terminology; it is used merely to place emphasis on what the author considers the important physical interpretation of the mathematical processes of analysis. The same interpretation is also considered to lead to a clearer understanding of the realization process. In fact, it is the realization process that is emphasized in this study. More precisely, it is concerned with the necessary and sufficient conditions, in terms of a direct synthesis procedure, for the realizability of an n^{th} order Y (or Z) matrix by a complete set of n independent voltage (current) branches and a necessary and sufficient set of dependent voltage (current) branches, where each branch is a two-terminal device as already mentioned.

The realization of the Y and the Z matrices are developed independently. A slight reflection of the matrix characteristics shows how such independence seems desirable, if not necessary. As we shall see, each and every entry in the Y -matrix formulation may be said to have an associated positive or negative sign - even zero entries. These signs of the entries completely determine the geometry of the independent voltage branches (that is, the tree) and by so doing set forth all possible ways in which the dependent voltage branches may be connected. The possible dependent branches are the $\frac{n(n-1)}{2}$ branches determined by the $n+1$ nodes of the network tree, as illustrated in Figure 2. The only exception to this statement is the case where a set of tree branches forms a linear subtree, with no other tree branches incident to the internal nodes of this linear subtree. In this case, the order cannot be determined from the signs alone; regardless of their order, however, the tree geometry is essentially invariant.

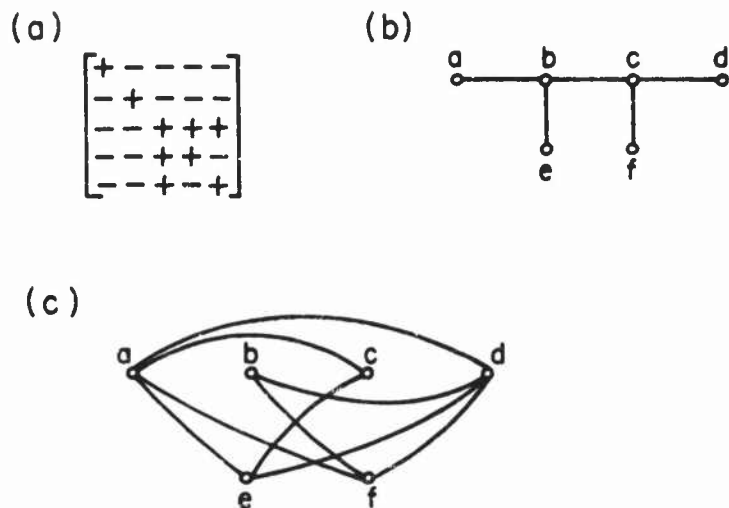

Figure 2. Examples of Branch Geometry Corresponding to a Particular Y Matrix: (a) Possible Signs of Entries for a Y Matrix; (b) Corresponding Network Tree; (c) Possible Dependent Voltage Branches.

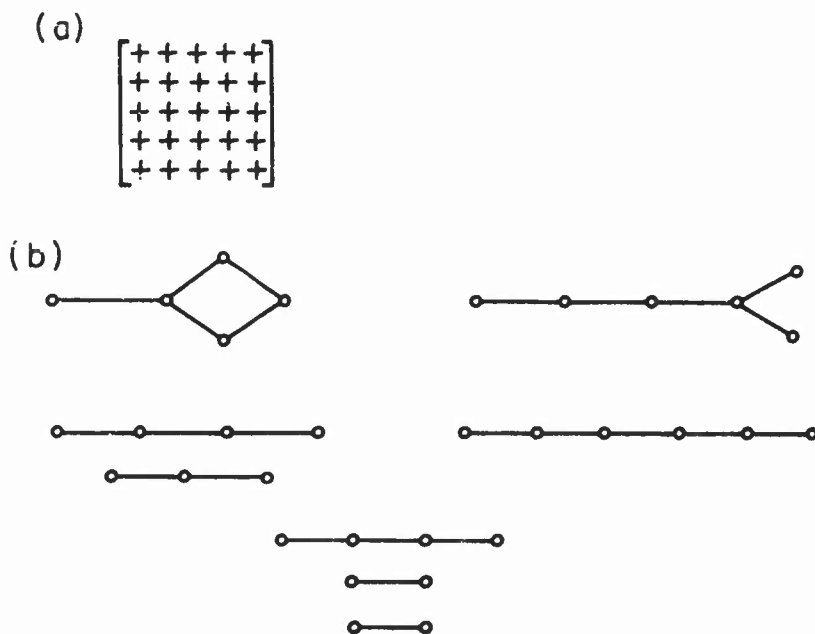

Figure 3. Possible Co-Trees for a Network with All Signs of the Entries in Its Z Matrix Positive: (a) Possible Signs for Entries of Z Matrix; (b) Five Corresponding Structures of the Independent Current Branches.

This characteristic of the Y matrix is dramatically opposite to that of the Z matrix. First, it is strongly suspected that a zero entry effectively has no sign associated with it.* Second, if all the signs are known, the topology of the independent current branches is still questionable. As an example, consider the fifth-order Z matrix having all signs positive. Five network structures, each having an independent current branch geometry that agrees with such a Z matrix, are shown in Figure 3. One main reason for these two differences is connectedness; the independent voltage branches must be connected, while the independent current branches need not be connected. Hence the signs of the Z matrix determine only a set of possible independent branch geometries, while the Z entry magnitudes determine which particular geometry is required.

In the next chapter we shall focus our attention on the Y matrix and in the third chapter we shall consider the Z matrix.

* It has recently been learned that half of the zero entries have an associated sign, and half have no associated sign.

II. SHORT-CIRCUIT ADMITTANCE MATRIX

2.1 Analysis

Consider the network graph of Figure 4 where the lines (branches) represent elements (R, L, and C, excluding mutual inductance), which are numbered arbitrarily and which meet at the junctions or nodes. In line with common practice, assign branch current directions and select an arbitrary tree such as indicated in Figure 4 by branches 1, 2, 3, and 4. For a particular branch, the direction of branch current flow is opposite to the direction of branch voltage rise as indicated by the convention adopted in Chapter I, Figure 1. The tree branch voltages (that is, v_1 , v_2 , v_3 , and v_4) become the set of independent branch voltages and appear in the final short-circuit equations of the network.

Now imagine welding a loop of "chain" to each tree branch and allowing the loop to assume a position such that each loop of chain crosses a branch only once, and crosses one and only one tree branch as is illustrated in Figure 5. The only tree branch crossed by a chain is the one to which that chain is welded. These positions are not altogether arbitrary, for reasons that will become apparent later. However, for the present, assume their positions arbitrary under the stipulation that each loop of chain crosses only one tree branch.

This "chain concept" is a justifiable tool and its great usefulness

* This concept of using a chain to define the branches of a cut set was first conceived by Professor N. DeClaris in 1954 and subsequently introduced to the author in 1959.

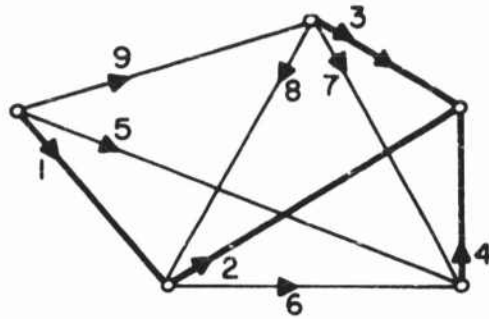

Figure 4. Example Network Graph with Branch Currents Identified.

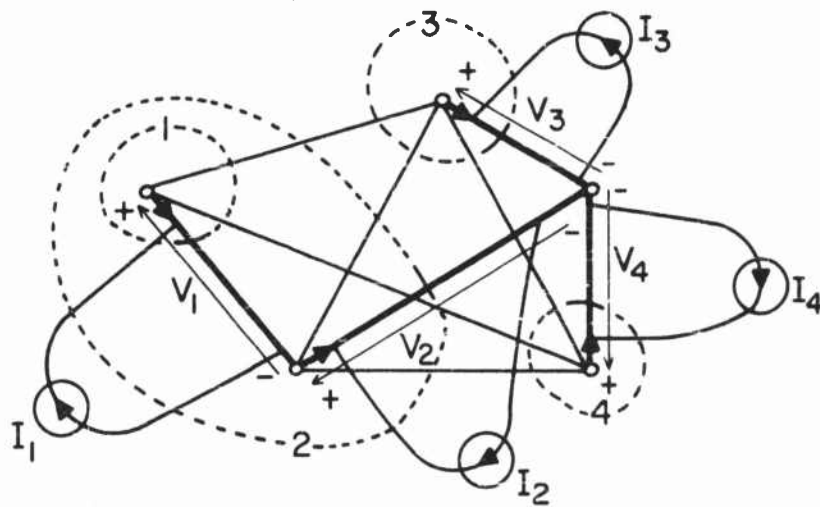

Figure 5. Example Network Graph with Regions Identified.
(Dashed lines define the various regions.)

becomes apparent later. For the present, however, the most important concept is not the chain, but rather the inner "region" for which the chain forms the boundary. The resultant short-circuit admittance matrix develops from applying Kirchhoff's current law to the currents entering and leaving these regions.

In Figure 5 the example regions are labeled and the branch excitation currents and response voltages are identified. Notice how each branch current enters one and only one region. The current for branch 1 appears to enter both region 1 and region 2. This is true, but since it not only enters region 2, but leaves region 2 as well, it can be considered as not having entered region 2 at all.

The facts describing the network and its regions are presented in the Region Table. Each entry in this table is -1 if the branch current enters the region according to the assigned direction, +1 if the branch current leaves the region, and 0 if the branch is totally inside or outside the region.

Region Table

	1	2	3	4	5	6	7	8	9
Region 1	+1	0	0	0	+1	0	0	0	+1
Region 2	0	+1	0	0	+1	+1	0	-1	+1
Region 3	0	0	+1	0	0	0	+1	+1	-1
Region 4	0	0	0	+1	-1	-1	-1	0	0

The columns of the Region Table relate the branch voltages in terms of the independent branch voltages. When one considers the table as a matrix, this means that

$$v = a_t V \quad , \quad (1)$$

where t stands for transpose and

$$v = \begin{bmatrix} v_1 \\ v_2 \\ \cdot \\ \cdot \\ v_9 \end{bmatrix} \quad , \quad V = \begin{bmatrix} V_1 \\ V_2 \\ V_3 \\ V_4 \end{bmatrix} \quad , \quad a = \begin{bmatrix} 1 & 0 & 0 & 0 & 1 & 0 & 0 & 0 & 1 \\ 0 & 1 & 0 & 0 & 1 & 1 & 0 & -1 & 1 \\ 0 & 0 & 1 & 0 & 0 & 0 & 1 & 1 & -1 \\ 0 & 0 & 0 & 1 & -1 & -1 & -1 & 0 & 0 \end{bmatrix} \quad .$$

The rows relate Kirchhoff's current law to the regions in so far as the network branches are concerned. This means

$$a_j = 0 \quad , \quad (2)$$

where

$$j = \begin{bmatrix} j_1 \\ j_2 \\ \cdot \\ \cdot \\ j_3 \end{bmatrix} \quad .$$

The generalized branch equation,

$$j + I' = y(v + E') \quad , \quad (3)$$

where

$$I' = \begin{bmatrix} I'_1 \\ I'_2 \\ \cdot \\ \cdot \\ \cdot \\ I'_9 \end{bmatrix} \quad E' = \begin{bmatrix} E'_1 \\ E'_2 \\ \cdot \\ \cdot \\ \cdot \\ E'_9 \end{bmatrix} \quad \text{and} \quad y = \begin{bmatrix} y_1 & & & & & & & & \\ & y_2 & & 0 & & & & & \\ & & \cdot & & & & & & \\ & & & \cdot & & & & & \\ 0 & & & & \cdot & & & & \\ & & & & & \cdot & & & \\ & & & & & & \cdot & & \\ & & & & & & & \cdot & \\ & & & & & & & & y_9 \end{bmatrix}$$

together with Equations (1) and (2) yield

$$a_j + a I' = a y a_t V + a y E' \quad , \quad (4)$$

or

$$a I' - a y E' = I = a y a_t V = Y^{sc} V \quad , \quad (5)$$

where the equivalent current sources acting in the independent branches,

$$I = \begin{bmatrix} I_1 \\ I_2 \\ I_3 \\ I_4 \end{bmatrix} \quad ,$$

and where y_i is the driving-point admittance in the i^{th} branch. In Equation (5), $a y a_t = Y^{sc}$ is the common complete short-circuit admittance matrix. Here Y^{sc} is called complete because it completely determines the response of the network in terms of the independent branch voltages. It is called a short-circuit admittance matrix because the ij entry $Y_{ij}^{sc} = I_i/V_j$ with all $I_{k \neq i}$ assuming such values as are necessary to set all $V_{k \neq j} = 0$. When these conditions are fulfilled, all tree branches

except the j^{th} branch may be short circuited without disturbing the state of the network.

For a better understanding of these concepts, carefully examine the Region Table, Figure 5, and the admittance matrix Y^{SC} . This study involves the Y_{ij}^{SC} entry and shows:

- 1) Y_{ij}^{SC} is a unique sum of branch admittances y_k .
- 2) The several y_k appearing in the ij sum, Y_{ij}^{SC} , are the admittances of those branches that enter and/or leave both region i and region j .
- 3) The signs of the y_k comprising Y_{ij}^{SC} will be plus if the branches enter both or leave both regions i and j (such as branches 9 and 5 with respect to regions 1 and 2), and will be minus if they enter one and leave the other region (such as branches 9 and 8 with respect to regions 3 and 2).
- 4) If region i and region j are separated or disjoint (such as regions 3 and 4), all the involved branches (branch 7) have to leave one region and enter the other region.
- 5) If region i includes region j , or vice versa, (such as regions 1 and 2), each of the involved branches (branches 9 and 5) has to enter both regions or leave both regions.
- 6) From steps 3, 4, 5, all the several y_k comprising the sum Y_{ij}^{SC} will have the same sign.
- 7) If branch i is a tree branch, then y_1 will appear only in the Y_{ii}^{SC} sum.

The conclusion drawn from the above is that given the network, its tree and the regions (and thus necessarily, as we shall see, the independent branch response voltages and excitation currents), the admittance matrix

is then known. Neither the dependent branch voltage directions nor the current directions or tables nor intermediate equations are necessary in the unique determination of Y^{SC} for the prescribed network.

At this point some of the obvious questions about "arbitrary assignments" should be answered. The quantities under scrutiny are shown in Figure 5. Note that each "chain" encircles one and only one of the nodes of the tree branch it is associated with. The example chains have been numbered according to the branch each chain is associated with, or "welded" to. The branch quantities V and I must "attack" the encircled node, or both be reversed for all branches simultaneously. If only the V (or I) directions are changed a minus sign will enter Equation (5) with the effect of destroying the signs of Y^{SC} so that $Y^{SC} \neq Y_t^{SC}$. Figure 6 shows most effectively how I_i is injected into the i^{th} region. Thus, once the regions are drawn, the independent branch currents and voltages are automatically specified. The question of arbitrary assignments now involves only the determination of the regions. Each chain may specify two regions, that is, it may be thrown to the right or to the left. Whatever way it is thrown has made no difference in everything discussed up to now. When one attempts to go in the opposite direction, however, (that is, given Y^{SC} determine the network), it becomes convenient to add the stipulation that no chain may cross another chain.

Theorem. Given any tree, it is possible to "throw the chains" (specifying the regions) such that no two chains cross each other.

Proof: Every tree has at least two ends. Throw these two end chains away from the tree (for example consider chains 1, 3, and 4 in Figure 6). Next consider each thrown chain, the tree branch it crosses,

and the encircled node of that same tree branch as an end node replacing the unencircled node of that tree branch. Now throw two more end chains, and so on, reductio ad absurdum.

This helps clear up the questions concerning arbitrary assignments. One other condition must be pointed out. In the preceding discussion, no direct statement was made restricting a branch admittance to a single R, L, or C element. There is no restriction. A branch admittance y_i is the driving-point admittance of that branch considered as a two-terminal network; therefore the example that has been carried through, could, in effect, be a 19-, 50-, . . . node network presented as a five-node network.

For example, consider first the network in Figure 5. The signs of the elements comprising Y^{SC} are:

$$Y_s^{SC} = \begin{bmatrix} + & + & - & - \\ + & + & - & - \\ - & - & + & - \\ - & - & - & + \end{bmatrix} \quad (6)$$

Here the matrix of the signs of Y^{SC} is denoted by Y_s^{SC} . The sign of Y_{ij}^{SC} is minus if region i and region j are disjoint. The sign of Y_{ij}^{SC} is plus if region i contains region j or vice versa. By inspection the elements of Y^{SC} are:

$$Y_{11}^{SC} = (y_1 + y_5 + y_9)$$

$$Y_{12}^{SC} = (y_9 + y_5)$$

$$Y_{13}^{SC} = (y_9)$$

$$Y_{14}^{sc} = (y_5)$$

$$Y_{22}^{sc} = (y_9 + y_8 + y_5 + y_2 + y_6)$$

$$Y_{23}^{sc} = (y_9 + y_8)$$

$$Y_{24}^{sc} = (y_5 + y_6)$$

$$Y_{33}^{sc} = (y_9 + y_8 + y_7 + y_3)$$

$$Y_{34}^{sc} = (y_7)$$

$$Y_{44}^{sc} = (y_7 + y_5 + y_6 + y_4)$$

with the sign of each Y_{ij}^{sc} as set forth in matrix (6).

Consider Figure 6 as a second example. This is the same network as Figure 5, but the chain defining region 2 is thrown in the opposite manner. For Figure 6,

$$Y_s^{sc} = \begin{bmatrix} + & - & - & - \\ - & + & + & + \\ - & + & + & - \\ - & + & - & + \end{bmatrix} \quad (8)$$

By inspection, the elements are the same as all elements in Equation (7) with the signs as set forth in matrix (8). This is as expected since regardless how the chains are thrown, each chain will cross the same set of branches. Note how the throwing of chain 2 in the opposite direction changed the reference direction of V_2 and I_2 . Note also how sign matrix (8) may be obtained from matrix (7) by multiplying row 2 and column 2 of matrix (7)

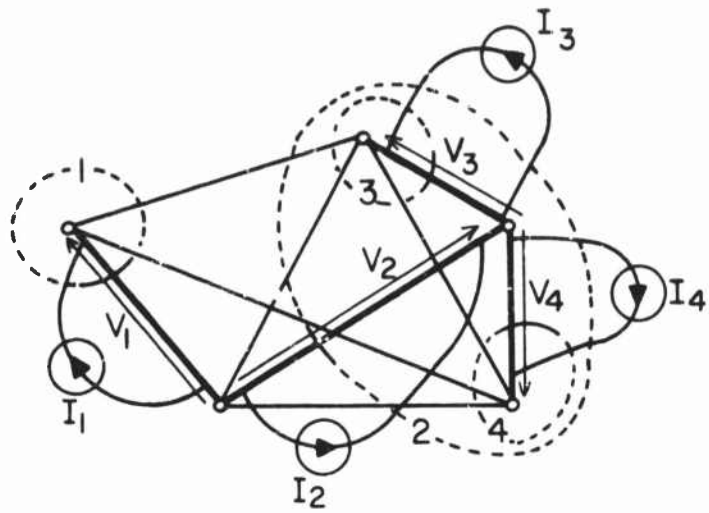

Figure 6. Variation One on Example Network Graph.
(Dashed lines define the various regions.)

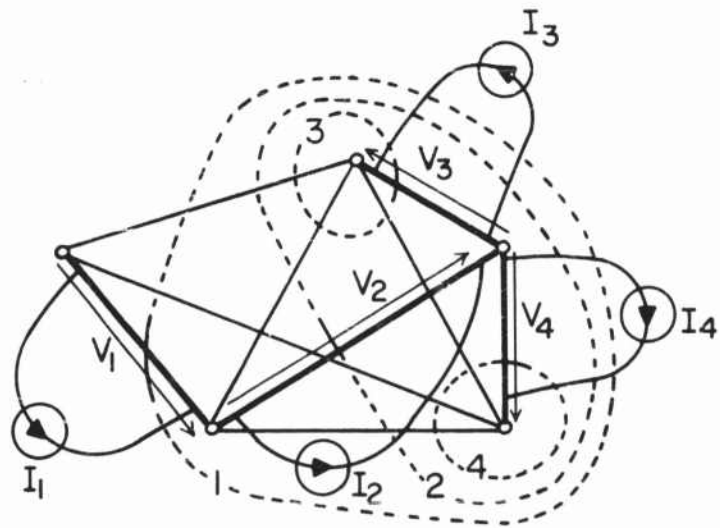

Figure 7. Variation Two on Example Network Graph.

by -1. The effect of reversing the direction in which chain i is thrown is to multiply row i and column i of Y^{SC} by -1. This does not alter the symmetric property or positive diagonal property of Y^{SC} .

If chain 1 in Figure 6 were thrown in the reverse manner along with chain 2, then the sign matrix for the resulting Figure 7 would be

$$Y_S^{SC} = \begin{bmatrix} + & + & + & + \\ + & + & + & + \\ + & + & + & - \\ + & + & - & + \end{bmatrix} \quad (9)$$

For a more complicated example, see Figure 8 where the branch current and voltages have been omitted. (This is acceptable since their directions are implied by the regions.) For Figure 8:

$$Y_S^{SC} = \begin{bmatrix} + & + & - & - & - & - \\ + & + & - & - & - & - \\ - & - & + & + & - & - \\ - & - & + & + & - & - \\ - & - & - & - & + & + \\ - & - & - & - & + & + \end{bmatrix} \quad (10)$$

The examples selected have been largely arbitrary. It is worthwhile to include two more examples of very specific types, the "star" tree and the "linear" tree. The star tree with all regions disjoint is shown in Figure 9 and its sign matrix is:

$$Y_S^{SC} = \begin{bmatrix} + & - & - & - & - & - \\ - & + & - & - & - & - \\ - & - & + & - & - & - \\ - & - & - & + & - & - \\ - & - & - & - & + & - \\ - & - & - & - & - & + \end{bmatrix} \quad (11)$$

The linear tree with all regions containing one another is shown in Figure 10

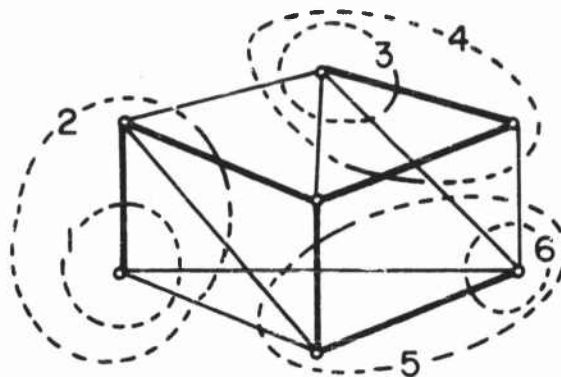

Figure 8. Second Example Network Graph.

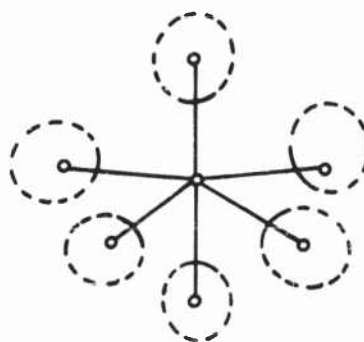

Figure 9. Star Network Tree.

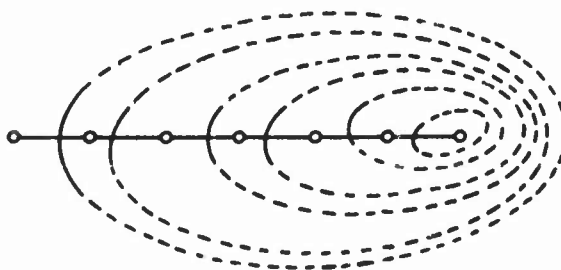

Figure 10. Linear Network Tree.

and has a sign matrix:

$$Y_S^{SC} = \begin{bmatrix} + & + & + & + & + & + \\ + & + & + & + & + & + \\ + & + & + & + & + & + \\ + & + & + & + & + & + \\ + & + & + & + & + & + \\ + & + & + & + & + & + \end{bmatrix} \quad (12)$$

The reason for their inclusion along with their generalizations should be obvious. They are two geometrical "limits" in the series of trees.

A natural question arising in this study is: When a short-circuit admittance matrix is specified, can the corresponding network be obtained? This is a difficult question to answer and must be broken into phases. First, in the simplest case, assume that one takes a network and obtains a Y^{SC} matrix in the manner just described. The network may then be obtained using only the Y^{SC} matrix. Furthermore, the Y^{SC} matrix may be altered by any combination of symmetric elementary operations without affecting the realizability of the network. Elementary operations are: (1) multiply any rows and corresponding columns by -1 , and (2) rearrange the rows and corresponding columns.

This analysis discussion concludes with an interesting observation concerning a tree and the set of "chains" related to that tree. When considering the tree by itself, the chains, which define the regions, may be interpreted as the dual of that tree. This is easy to visualize by considering the normal process of constructing a dual network. During this construction, each branch of the original network is associated with or "crossed" by a single dual branch. Since the tree branch current is identically zero, the terminals of the dual branch may be joined so that

its branch voltage is identically zero. Joining the two ends of each dual branch identifies it with the chain of its dual tree branch. Connectedness of the tree is retained in the dual graph by allowing the chains to touch, but not cross, in the manner stipulated by the tree geometry. For an example of this, see Figure 11. It is also worth while to note that since the co-tree is not necessarily planar (see Chapter I) it will not have a dual graph in general. Therefore this observation is not expected to carry over into the impedance analysis of Chapter III.

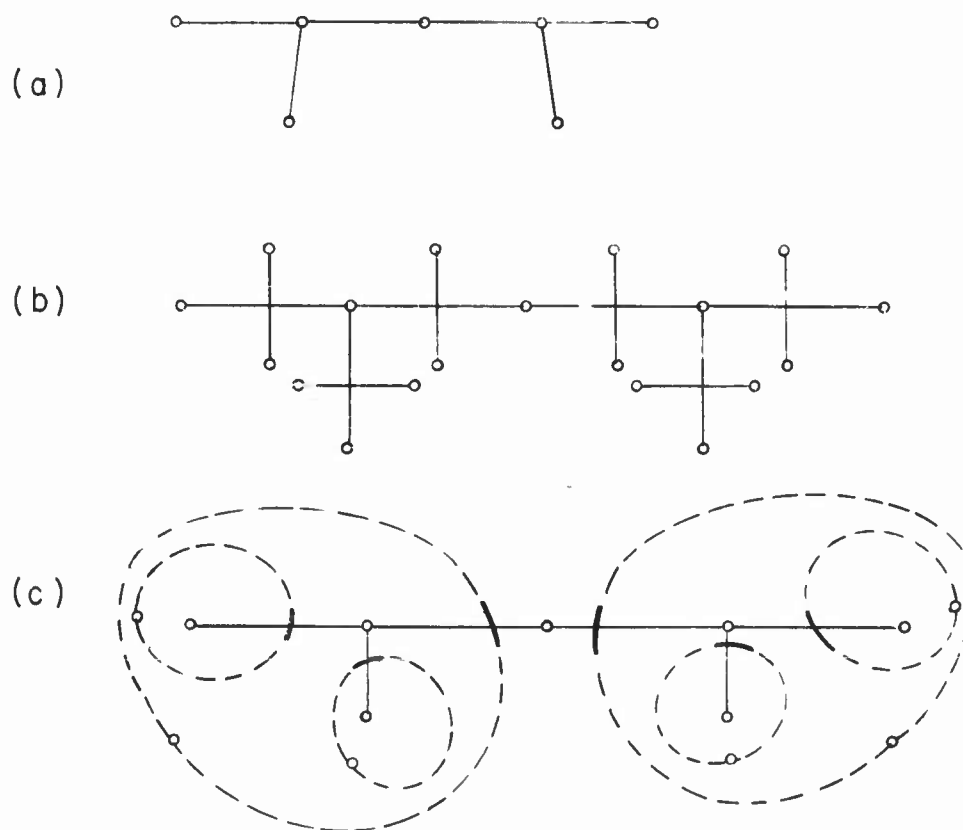

Figure 11. Construction of Network-Tree Dual. (a) Network Tree. (b) Network Tree with Dual Branches. (c) Network Tree with Dual Branches Short Circuited.

2.2 Direct Synthesis of a Completely Specified Y^{SC} Matrix

The process of building the tree and then the network from a given Y^{SC} (and thus Y_s^{SC}) hinges on the concept of two chains acting as one. Two chains, say i and j , act as one when the signs in row i and j of Y_s^{SC} are identical with the possible exception being the ij entries. The ii and jj entries are naturally plus and the ij and ji entries are plus if they are concentric, and minus if they are disjoint. When two chains act as one, and are concentric, the tree branches they cross form a linear subtree as indicated in matrix (6) rows 1 and 2, and Figure 5, branches 1 and 2. When two chains act as one, and are disjoint, the tree branches they cross form a star subtree as indicated in matrix (6) rows 3 and 4, and Figure 5, branches 3 and 4. Regardless of the size or shape of the tree, there are at least two sets of chains acting together. Figure 8 and matrix (10) are another obvious example of this effect.

This concept of linear and star subtrees must be extended even further. Elementary linear and star subtrees are shown in Figure 12a and 12b. Chains i and j act alike and thus the corresponding rows i and j must be identical as far as the rest of the network is concerned. Conversely, if rows i and j are alike except for the ij and ji entries, these rows correspond to linear or star subtrees, depending on the sign of the ij entry. More generally, two subtrees may be considered connected in the linear or star fashion shown in Figure 12c and 12d. Here the entries in all the rows corresponding to branches in the tree section i can be made identical in so far as the rest of the network, section j , is concerned. Conversely, if a set of rows are alike, except for those entries showing the interrelationships within that corresponding set of branches,

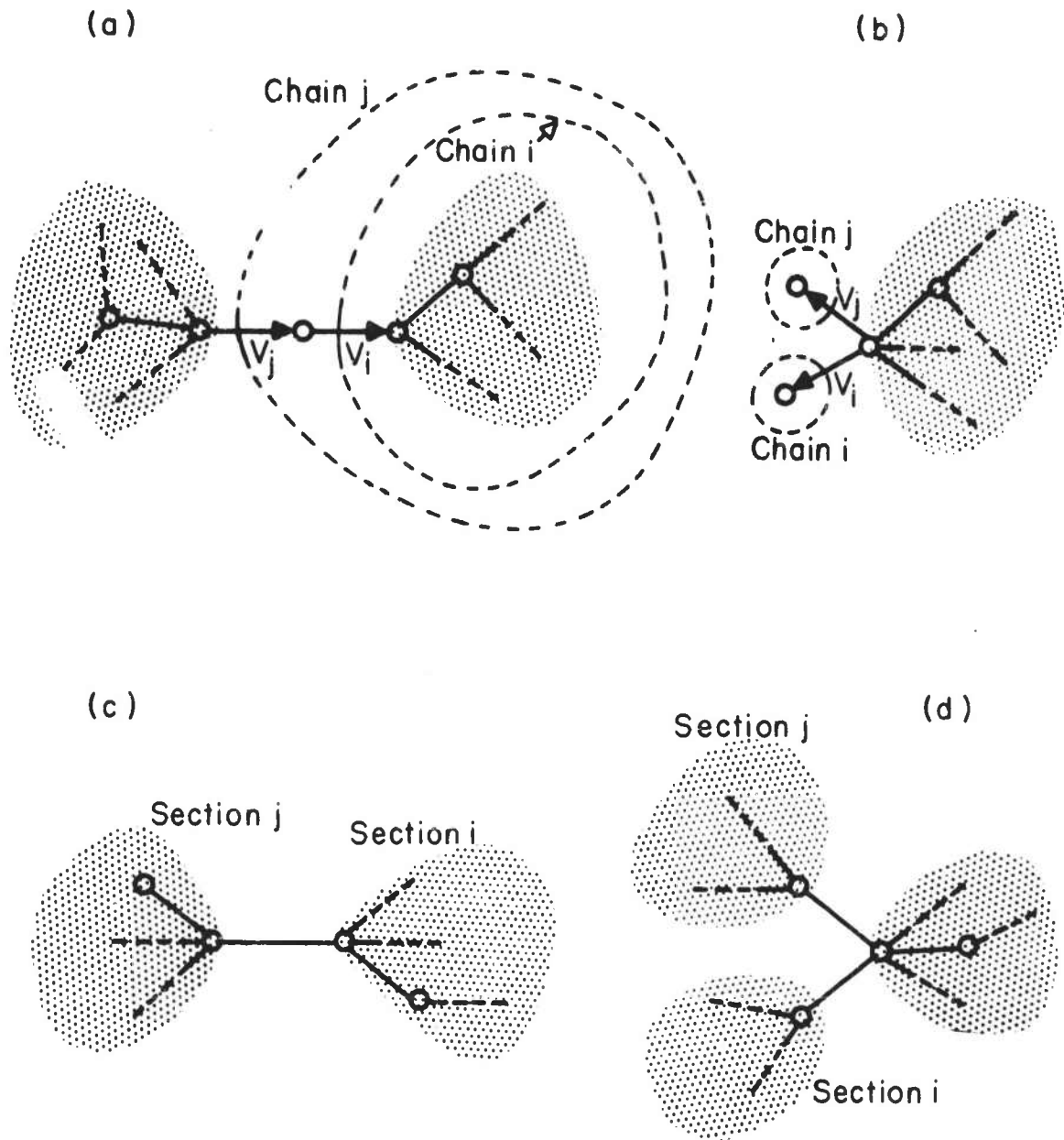

Figure 12. Subtrees (a) Linear Elementary Subtree, (b) Star Elementary Subtree, (c) Linear General Subtree, (d) Star General Subtree.

that corresponding set of branches must form a subtree that is connected to the rest of the network in either the linear or star method of Figure 12c and 12d.

When two branch chains act alike and their relationship to one another is known, one of the corresponding branches may be ignored; that is, all of the signs of one corresponding row are redundant as far as the rest of the network is concerned. Since this is true, the rows may be merged into one with the physical effect of reducing the number of branches in the tree. In other words, the size of the tree is reduced. Repeated application of this process is the means for producing the tree for a given sign matrix. For a better understanding of this process, visualize a tree. Consider each branch as a subtree or section of a tree. Gradually allow these sections to grow and thus absorb one another until, in the limit, Figures 12c or 12d result. This is the effect of gradually merging rows in the sign matrix. If this process is interrupted, thus indicating a contradiction, the tree does not exist.

This process of building a tree will be further explained in conjunction with the example shown in Figure 13 where the original complete sign matrix is Figure 13a. Start by removing all redundant rows corresponding to concentric chains, or linear portions of the tree (Figure 13b). These chains act alike and thus the doubly (or, in general, multiply) numbered branches (rows) are considered as single branches during the remainder of the process. Next remove all redundant rows that act alike and correspond to disjoint chains (there must be at least two of them), and draw these star-like ends of the tree. During this stage and the following stages, whenever two rows are compared, any of the columns whose corresponding rows

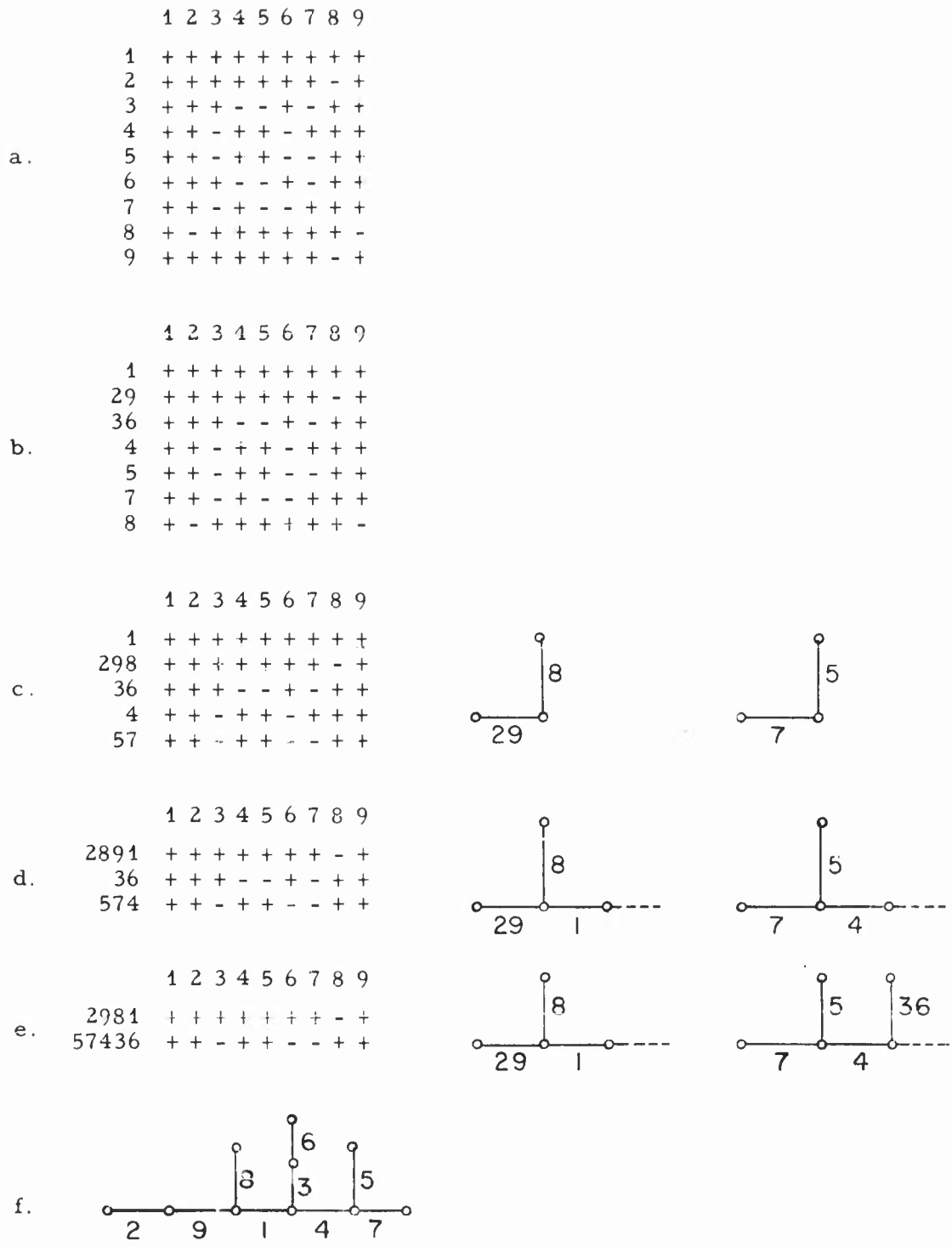

Figure 13. Example of Network-Tree Realization.

have been deleted may be ignored if one of the comparing rows is doubling for that deleted row. For instance, when comparing rows 29 and 8, column 9 may be ignored since row 9 was deleted and row 2 is doubling for row 9 (see Figure 13c). This basic process just repeats itself, and every time a row is deleted, that branch is added to the drawing. In Figure 13d, row 4 has been deleted, and branch 4 drawn linearly with 5 and 7, and similarly branch 1, linearly with 29 and 8. In Figure 13e branch 36 has been added star-like with branches 5, 7, and 4. At this stage, the tree has been reduced just as in Figure 12c. In Figure 13f the two halves have been brought together and the tree geometry has been completed.

This is a once-through process. If at any stage there are no two rows that act alike, then there is no corresponding tree for that sign matrix. When one of two rows is to be deleted during the process, it is immaterial which row is deleted. It may also be necessary mentally to multiply a row and a corresponding column by -1 to determine two rows that act alike. This is illustrated in a second example, Figure 14. Sign matrix (13) has been included as an example where no corresponding tree exists:

$$Y_{sc}^s = \begin{bmatrix} + & + & + & + & + \\ + & + & + & + & - \\ + & + & + & - & + \\ + & + & - & + & - \\ + & - & + & - & + \end{bmatrix} \quad (13)$$

After the tree corresponding to a given admittance matrix has been produced, the equations relating the branch admittances with the matrix elements are immediate, for example, see Equations (7). From these equations one may ascertain the realizability of the elements. It is important

	1	2	3	4	5	6	7	8	9
a.	1	+	+	+	-	-	+	+	-
	2	+	+	+	-	+	-	+	+
	3	+	+	+	-	+	-	-	+
	4	-	-	-	+	+	-	-	+
	5	-	+	+	+	+	+	+	+
	6	+	-	-	-	+	+	-	-
	7	+	+	-	-	+	-	+	+
	8	+	+	+	-	+	-	-	+
	9	-	+	+	+	+	-	+	+

	1	2	3	4	5	6	7	8	9
b.	14	+	+	+	-	-	+	+	-
	2	+	+	+	-	+	-	+	+
	38	+	+	+	-	+	-	-	+
	5	-	+	+	+	+	+	+	+
	6	+	-	-	-	+	+	-	-
	7	+	+	-	-	+	-	+	+
	9	-	+	+	+	+	-	+	+

	1	2	3	4	5	6	7	8	9
c.	14	+	+	+	-	-	+	+	-
	2	+	+	+	-	+	-	+	+
	387	+	+	+	-	+	-	-	+
	56	-	+	+	+	+	+	+	+
	9	-	+	+	+	+	-	+	+

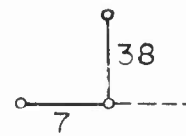
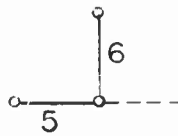

	1	2	3	4	5	6	7	8	9
d.	14	+	+	+	-	-	+	+	-
	3872	+	+	+	-	+	-	-	+
	569	-	+	+	+	+	+	+	+

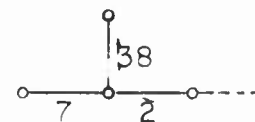
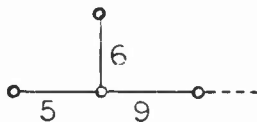

	1	2	3	4	5	6	7	8	9
e.	14569	+	+	+	-	-	+	+	-
	3872	+	+	+	-	+	-	-	+

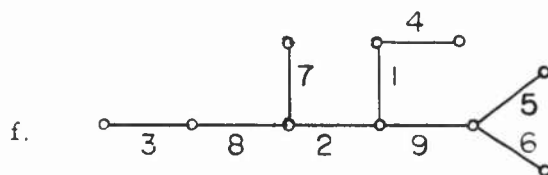
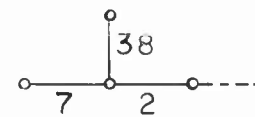
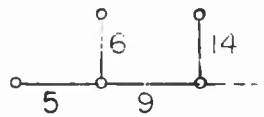

Figure 14. Second Example of Network Tree Realization.

to note that all the Y_{ij}^{sc} entries in the complete short-circuit admittance matrix must be driving-point admittances. This points out one of the difficulties in discussing the realization procedure only in terms of resistive networks. Any Y matrix of a resistive network automatically has driving-point functions for each and every entry. This follows since there is no difference between driving-point and transfer functions of a resistive network - each is merely a constant. This, however, does not hold for any Y matrix of an RLC network, because there is a definite distinction between transfer and driving-point functions. Therefore, throughout the description of the Y^{sc} realization, each entry Y_{ij}^{sc} must be a driving-point function multiplied by its associated positive or negative sign. Under this stipulation, the preceding and following realizations are not restricted to resistive networks, but are valid for general RLC networks. In the comments and general realization procedure that follows, however, the entries or "magnitudes" will be referred to as though they were resistive constants in order to make the theory easier to understand. Whenever an important distinction between the resistive case and the RLC case arises, this distinction will be pointed out and discussed.

In conjunction with the realization of a complete short-circuit admittance matrix, consider the linear subtree, branches 2 and 9, in Figure 13. In proceeding from step e to step f, these branches may be ordered in one of two ways. Although the proper order will reveal itself automatically through the magnitude equations, it is more convenient to order them properly during the transition from step e to step f. The correct order is learned by comparing the magnitudes of Y_{2k}^{sc} and Y_{9k}^{sc} where k is any other branch. If Y_{9k}^{sc} is the larger, then branch 9 is closer to

branch k than branch 2 is. In Figure 13, Y_{9k}^{sc} will always be the larger. This general characteristic becomes obvious upon considering Figure 12. In Figure 12, the order of branch i and branch j is specified by the magnitudes of Y_{ik}^{sc} and Y_{jk}^{sc} where k is any branch in the right or left extension. Let k be contained in the left extension. Since the magnitude of Y_{ik}^{sc} is the sum of all admittances cut by chains k and j , and since all branches cut by chains k and i are also cut by chains k and j but not the reverse, the magnitude of Y_{jk}^{sc} must be equal to or larger than the magnitude of Y_{ik}^{sc} . Should the magnitudes be equal for all k in both extensions, then only branches i and j meet at their common node in the complete network and their order is arbitrary. This comparison of magnitudes seems at first to apply only to resistive networks. It can easily be interpreted for RLC networks, however. The concept that Y_{ij}^{sc} is larger than Y_{rs}^{sc} means that $Y_{ij}^{sc} \geq Y_{rs}^{sc}$ for single-element kind networks only. When Y_{ij}^{sc} is a general positive real network function, then the concept Y_{ij}^{sc} is larger than Y_{rs}^{sc} means that $Y_{ij}^{sc} \supset Y_{rs}^{sc}$; which is equivalent to saying that $Y_{ij}^{sc} - Y_{rs}^{sc}$ is also a positive real network function.

The preceding method is a very quick and easy method which is guaranteed to be a once-through process in realizing the network. It tests for realizability through producing the network itself. Its primary application lies in realizing a network from a given complete short-circuit admittance matrix in which the vast majority of the entries are specified positive real network functions times ± 1 .

When the given matrix is large and contains several "arbitrary" unspecified entries, a more sophisticated approach is desirable. In such an approach, it is necessary to "preamble" (that is, analyze and rearrange) the problem before proceeding with the realization process. On the basis

of this, the following procedure is presented as a completely general solution of the problem. Rather than build the network tree directly, one rearranges the elements of the matrix and places them in such an arrangement that the corresponding network tree is as visible in the matrix as it would be if it were drawn on paper.

2.3 Realization of Y^{SC} with Zero Entries

A difficult problem in modern network theory has been that of reducing a given n^{th} order short-circuit admittance matrix to a realizable network. Although the entrance of unspecified ij entries into the matrix may reduce the number of restraints between various entries, such "arbitrary" entries tend to complicate this synthesis problem. This complication arises because the answer to the realizability problem is no longer a straightforward "yes" or "no," but rather is a "no" or a conditional "yes," where the conditions depend on the many restrained assignments of values to the unspecified entries. It should be obvious that such an assignment critically affects both the realizability and complexity of the final network.

In presenting a solution to this general problem, we break the problem into two parts, the first dealing with the matrix of the ij entry signs, and the second dealing with the magnitudes of the entries. The signs are referred to as s_{ij} , the sign matrix as Y_s^{SC} , and the magnitudes as simply y_{ij} . Thus y_{ij} represents the positive sum of branch admittances that are crossed by both the chains defining the i and j regions, and $Y_{ij}^{SC} = s_{ij} y_{ij}$. Whenever y_{ij} is said to contain y_{kr} , or $y_{ij} \supseteq y_{kr}$, all branch admittances comprising the sum y_{kr} are present in the sum of terms comprising y_{ij} .

The first problem concerns Y_s^{SC} and its corresponding network tree. Before developing the characteristics of Y_s^{SC} , however, a few comments on terminology are necessary. Where it is necessary to distinguish types of trees and subtrees, the following will be referred to (see Figure 15):

1. Maximal Tree: With regard to a particular network, any tree that contains every node of the network is a maximal tree.
2. Minor Tree: A subtree that can be completely severed from the maximal tree by splitting one node exactly in half is a minor tree.
3. Minor r-Tree: A subtree that can be completely severed from the maximal tree by "splitting" r nodes in half in a minor r-tree.

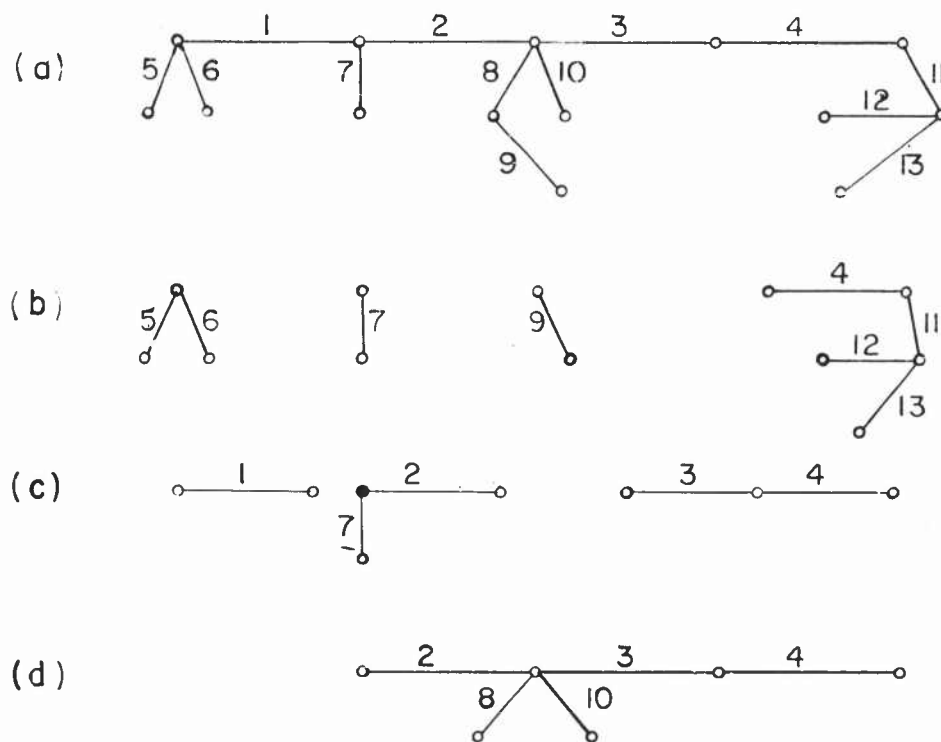

Figure 15. Examples of Subtree Types: (a) Maximal Tree; (b) Minor Trees; (c) Minor 2-Trees; (d) Minor 3-Trees.

Let us now examine the characteristics involving any two branches in the maximal tree, say b_1 and b_n . From the implicit characteristics of a tree, there is a unique linear subtree connecting b_1 to b_n such that b_1 and b_n define the two end branches in this linear subtree. This general case is shown in Figure 16a where the linear subtree branches connecting b_1 to b_n are termed Section A_2 and where the minor trees connected to the linear subtree nodes are termed Section A_1 , Section B_2 , Section B_3 , . . . , Section B_n , and Section A_n respectively proceeding from left to right as indicated. Assume that all tree-branch chains are thrown in the convenient manner indicated in Figure 16a such that:

1. All chain-defining regions of Section A_1 are contained in region b_1 and are disjoint from region b_n .
2. All chain-defining regions of Section A_n are contained in region b_n and are disjoint from region b_1 .
3. All chain-defining regions of Section A_2 contain either region b_n or region b_1 but not both.
4. All chain-defining regions of Section B_1 are disjoint from both region b_1 and region b_n .

Under these assumptions, Y_s^{sc} takes the partitioned form of matrix (15). (A complete, simplified partitioned example is shown in Figure 16b where n has been set equal to 6.) In matrix (15),

$$Y_s^{sc} = \begin{array}{c}
\begin{array}{c} b_1 \\ b_n \\ A_1 \\ \vdots \\ A_n \\ A_2 \\ \vdots \\ B \end{array} \left\{ \begin{array}{c} + \\ - \\ + \\ \vdots \\ + \\ - \\ + \\ \vdots \\ - \\ + \\ - \\ - \\ \vdots \\ - \end{array} \right\} \begin{array}{c} - \\ + \\ - \\ \vdots \\ - \\ + \\ - \\ \vdots \\ + \\ - \\ - \\ - \\ \vdots \\ - \end{array}
\end{array} \quad (15)$$

only the signs of immediate interest are indicated. In analyzing matrix (15), note that the branches may be grouped into two sets:

Set 1, where all branches i have $s_{1i} = s_{ni}$;

Set 2, where all branches j have $s_{1j} \neq s_{nj}$.

This grouping yields

Set 1 = Sections B_i = Section B ;

Set 2 = Sections A_1, A_2, A_n , and branches b_1 and b_n .

No elementary operation will destroy this grouping. One group will always consist only of Section B, while the other group contains the remainder regardless of how the chains were thrown. The most important element

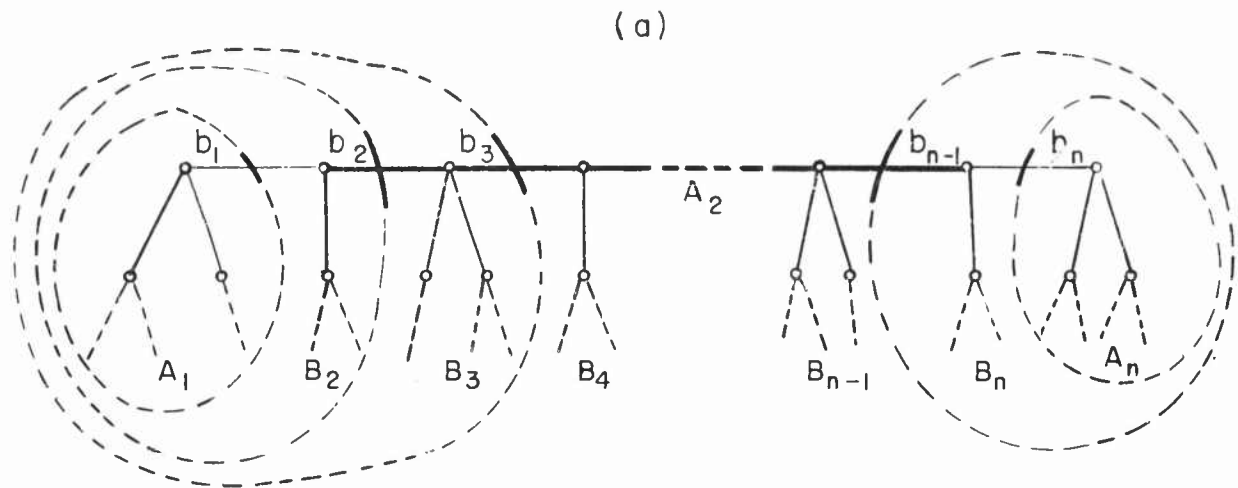

(b)

b_1	+	+	+	-	-	-	+	-	-	-	-	-	-
b_2	+	+	+	-	-	-	+	+	-	-	-	-	-
b_3	+	+	+	-	-	-	+	+	+	-	-	-	-
b_4	-	-	-	+	+	+	-	-	-	-	+	+	+
b_5	-	-	-	+	+	+	-	-	-	-	-	+	+
b_6	-	-	-	+	+	+	-	-	-	-	-	-	-
A_1	+	+	+	-	-	-	T_{A_1}	-	-	-	-	-	-
B_2	-	+	+	-	-	-	-	T_{B_2}	-	-	-	-	-
B_3	-	-	+	-	-	-	-	-	T_{B_3}	-	-	-	-
B_4	-	-	-	-	-	-	-	-	-	T_{B_4}	-	-	-
B_5	-	-	-	+	-	-	-	-	-	-	T_{B_5}	-	-
B_6	-	-	-	+	+	-	-	-	-	-	-	T_{B_6}	-
A_6	-	-	-	+	+	+	-	-	-	-	-	-	T_{A_6}

Figure 16. General Tree (a) and (b) Example Y^{sc} for $n = 6$. (Heavy line in general tree diagram represents Section A_2 .)

in this process is s_{1n} , since it determines which set is Section B, and which set is Section A_1 , A_2 , and A_n . As for the limiting case, if Set 1 is void, then branches b_1 and b_n form a linear minor 2-tree together with Section A_2 ; if Set 2 consists only of b_1 and b_n , then those two branches have a node in common and form a star subtree. In either of these limiting cases, b_1 and b_n may be merged appropriately. Thus in a sign matrix, two rows, i and j , effectively partition the sign matrix as indicated in matrix (15) due to the grouping of signs s_{ik} and s_{jk} .

Continue this partitioning by examining the corresponding sign relations that exist between any branch b_b in Section B_i and either branch b_1 or branch b_n . Branch b_b has been labeled in Figure 17 yielding a grouping, similar to Equation (16), as follows:

$$b_1 \text{ and } b_b \left\{ \begin{array}{l} \text{Set 1 } b_1, b_b, \text{ Sections } A_1, A_{21}, B_{iv} \\ \text{Set 2 } b_n, \text{ Sections } A_n, A_{2n}, B_j, B_{ix} \end{array} \right. \quad (17a)$$

$$b_n \text{ and } b_b \left\{ \begin{array}{l} \text{Set 1 } b_n, b_b, \text{ Sections } A_n, A_{2n}, B_{iv} \\ \text{Set 2 } b_1, \text{ Sections } A_1, A_{21}, B_j, B_{ix} \end{array} \right. \quad (17b)$$

where

$$b_b \in \text{Section } B_i,$$

$$i \neq j,$$

Sections A_{21} and A_{2n} are those portions of A_2 comprising part of the linear subtree connecting b_b to b_1 and b_n respectively;

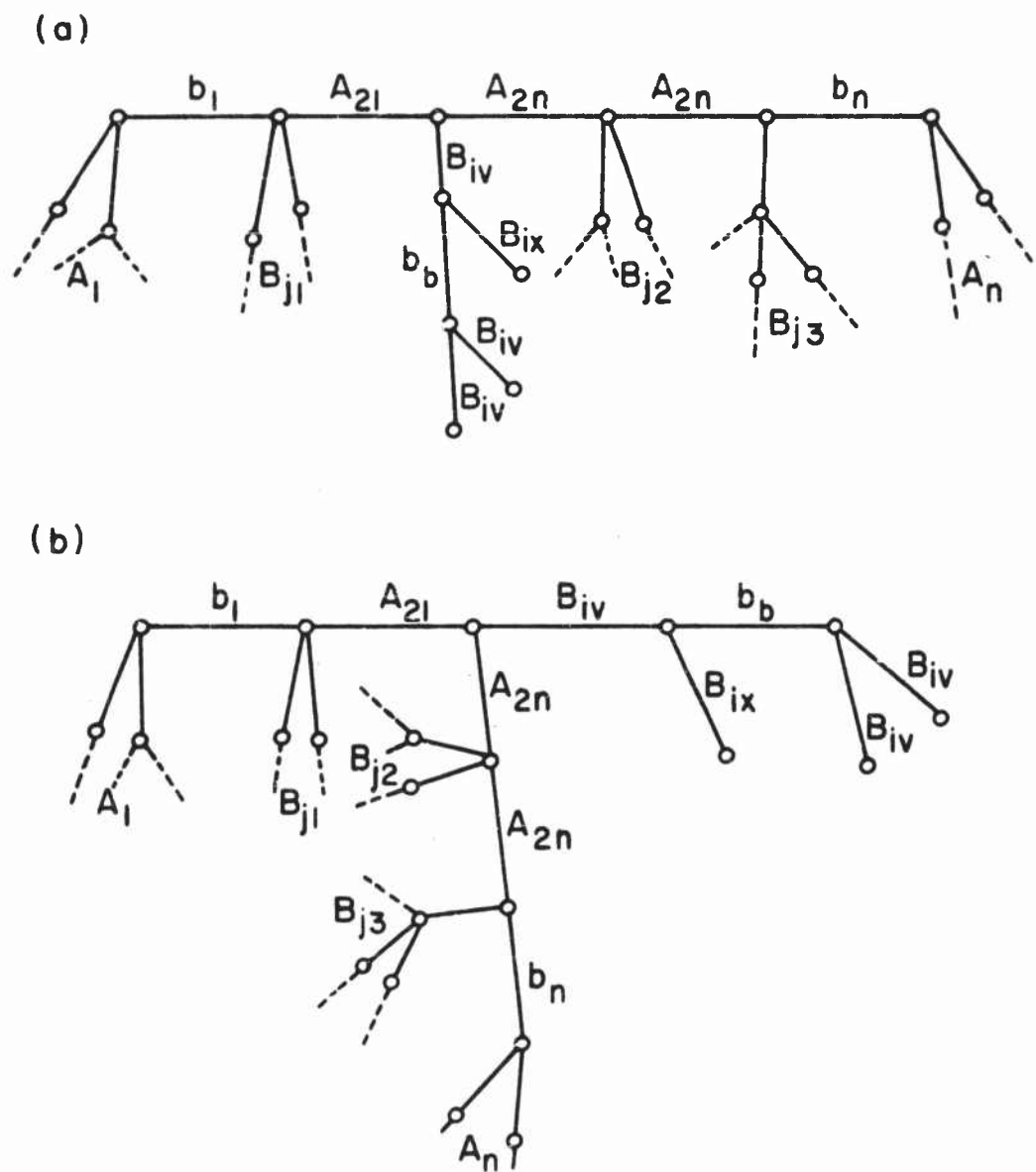

Figure 17. Example of b_b Branch. (a) Branch b_b as It Appears in General Tree, (b) Branch b_b as It Appears When b_b and b_1 Define the General Tree.

Section B_{iv} represents the branches of minor tree B_i that comprise a portion of any linear subtree that has branches b_b and b_1 or b_n as two of its components;

Section B_{ix} represents the branches of minor tree B_i that are not contained in Section B_{iv} .

Once again, no elementary operation will destroy the grouping of Equation (17a) or (17b). Note that branch b_b , which is any branch in one of the B_i sections, becomes any branch in minor tree B_i for this analysis. Combining the results of Equation (17a) or (17b) with Y_s^{sc} , Equation (15), the sign matrix may be further partitioned as follows:

$$Y_s^{sc} = \begin{array}{l} b_1 \\ b_n \\ A_1 \text{ and } A_{21} \\ A_n \text{ and } A_{2n} \\ b_b \\ B_{iv} \\ B_{ix} \text{ and } B_j \end{array} \left[\begin{array}{cccc|cccc} + & - & + & & - & - & - & - \\ - & + & - & & + & - & - & - \\ + & - & S_1 & & N & - & N & S_3 \\ - & + & N & & S_2 & - & N & S_4 \\ - & - & - & & - & + & + & - \\ - & - & N & & N & + & & N \\ - & - & S_3 & & S_4 & - & N & \end{array} \right] \quad (18)$$

Note that Y_s^{sc} of matrix (18) was developed in two independent ways simultaneously. First, if the network tree was given with the chains thrown

correctly, it was immediately known. Second, with just the matrix given, comparing signs yielded the labeled partitions, after which the signs in rows b_1 , b_n , and b_b were fixed to conform with the first method by multiplying the appropriate rows and columns by minus one. Making these signs conform guarantees that all chains were correctly thrown. Having been reduced to this form, matrix (18) vividly presents the first criterion for realizability as stipulated by the sign alone - all the signs in the partitions labeled N must be negative. The appearance of any positive signs in the N partitions indicates a geometric contradiction, as can be seen from Figure 16, and hence an unrealizable network.

Sign matrix (18) may be now further partitioned to separate A_1 from A_{21} , A_n from A_{2n} , and B_j from B_{ix} . These separations will provide the remaining sign criteria for the matrix to be realizable with respect to sign. The following separation is based on the original assumption that the chains were thrown correctly, an assumption that is guaranteed by fixing the signs in rows b_1 , b_n , and b_b of matrix (18).

2.31 A_1 and A_{21}

All A_{21} regions contain each other and contain all A_1 regions. Therefore, from matrix (18) any row through S_1 having a minus sign in S_1 must belong to A_1 along with the corresponding column. Each minus sign therefore specifies two A_1 branches. This essentially restricts particular branches from belonging to A_{21} , since a branch may exist in A_1 yet have no corresponding minus signs in S_1 . Any branches that conform to this latter situation exist together with b_1 as a minor 2-tree where one of the two "split" nodes connects b_1 to A_{21} and the other connects one of the conforming A_1 branches to the remaining branches in A_1 .

All A_1 regions are disjoint with all B regions; therefore any row through S_1 having a plus sign in S_3 must belong to A_{21} . This essentially restricts particular branches from belonging to A_1 , since a branch may exist in A_{21} yet have no corresponding plus signs in S_3 . Any branches that conform to this latter situation exist together with b_1 as a minor 2-tree where one of the two "split" nodes connects b_1 to A_1 and the other connects one of the conforming A_{21} branches to the remainder of the network.

Any row through S_1 having a minus sign in S_1 and a plus sign in S_3 represents a contradiction, hence an unrealizable network. This branch was relegated to the A_1 and A_{21} partition by columns b_1 , b_n , and b_b but is restricted from belonging to A_{21} by S_1 , and from belonging to A_1 by S_3 , therefore the contradiction.

Any rows through S_1 having no minus signs in S_1 and no plus signs in S_3 can be assigned to A_1 or A_{21} only by comparing appropriate y_{ij} magnitudes. Branches x illustrating this are shown in Figure 18. These

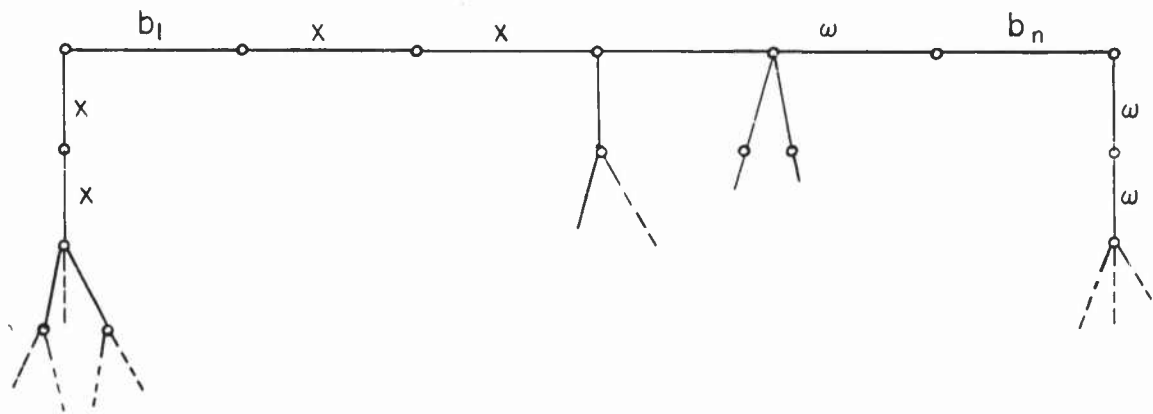

Figure 18. Examples of Branches Requiring Comparison of Magnitudes to Determine Correct Position.

branches may be separated by comparing y_{ij} magnitudes in, for example, column n since $y_{i1} \supseteq y_{1n} \supseteq y_{kn}$, where i and k are rows belonging to A_{21} and A_1 respectively. At the conclusion of this step, matrix (18) becomes

$$Y_s^{sc} = \begin{array}{c} \begin{array}{cccc|cccc} b_1 & + & - & + & + & - & - & - & - \\ b_n & - & + & - & - & + & - & - & - \\ A_1 & + & - & T_1 & P & N & - & N & N \\ A_{21} & + & - & P & P & N & - & N & S_3 \\ A_n \text{ and } A_{2n} & - & + & N & N & S_2 & - & N & S_4 \\ b_b & - & - & - & - & - & + & + & - \\ B_{iv} & - & - & N & N & N & + & & N \\ B_{ix} \text{ and } B_j & - & - & N & S_3 & S_4 & - & N & \end{array} \end{array} \quad (19)$$

where the added partition has been drawn heavy, the partitions labeled P contain all positive signs, and T_1 is the sign partition dealing exclusively with the minor tree A_1 .

2.32 A_n and A_{2n}

All A_{2n} regions contain each other and contain all A_n regions. Therefore, any row through S_2 having a minus sign in S_2 must belong to A_n along with the corresponding column. Each minus sign thus specifies two A_n branches. This essentially restricts particular branches from belonging to A_{2n} since a branch may exist in A_n yet have no corresponding

minus signs in S_2 and any such branches will exist together with b_n as a minor 2-tree, where one of the two "split" nodes connects b_n to A_{2n} and the other connects one of the conforming A_n branches to the remaining branches in A_n .

All A_n regions are disjoint with all B regions; therefore, any row through S_2 having a plus sign in S_4 must belong to A_{2n} . This essentially restricts particular branches from belonging to A_n , since a branch may exist in A_{2n} yet have no corresponding plus signs in S_4 , and any such branches will exist together with b_n as a minor 2-tree where one of the "split" nodes connects b_n to A_n and the other connects one of the conforming A_{2n} branches to the remainder of the network.

Any row through S_2 having a minus sign in S_2 and a plus sign in S_4 represents a contradiction and hence an unrealizable network. This branch was relegated to the A_n and A_{2n} partition by columns b_1 , b_n , and b_b , but is restricted from belonging to A_{2n} by S_2 and from belonging to A_n by S_4 , hence a contradiction.

Any rows through S_2 having no minus signs in S_2 and no plus signs in S_4 can be assigned to A_n or A_{2n} only by comparing appropriate y_{ij} magnitudes. Branches ω corresponding to this situation are shown in Figure 18. These branches may be separated by comparing y_{ij} magnitudes in, for example, column 1, since $y_{i1} \geq y_{in} \geq y_{kn}$, where i and k are rows belonging to A_{2n} and A_n respectively.

At the conclusion of this step, matrix (19) becomes

$$Y_s^{sc} = \begin{array}{c|cccc|cccc} b_1 & + & - & + & + & - & - & - & - & - \\ b_n & - & + & - & - & + & - & - & - & - \\ \hline A_1 & + & - & T_1 & P & N & N & - & N & N \\ \hline A_{21} & + & - & P & P & N & N & - & N & S_3 \\ \hline A_{2n} & - & + & N & N & P & P & - & N & S_4 \\ \hline A_n & - & + & N & N & P & T_n & - & N & N \\ \hline b_b & - & - & - & - & - & - & + & + & - \\ \hline B_{iv} & - & - & N & N & N & N & + & & N \\ \hline B_{ix} \text{ and } B_j & - & - & N & S_3 & S_4 & N & - & N & \end{array} \quad (20)$$

where the new partitions have been drawn dark, and T_n is the sign partition dealing exclusively with minor tree A_n .

2.33 B_j and B_{ix}

Section B_j consists of minor trees to the left of B_i and minor trees to the right of B_i as shown in Figure 16. Any row in the B_j and B_{ix} partition with a plus sign in S_3 belongs to a left-hand B_j minor tree and any row with a plus sign in S_4 belongs to a right-hand B_j minor tree. In addition, if A_{21} is not empty, then there must be a branch in A_{21} whose signs in S_3 are positive for every branch belonging to a left-hand, B_j minor tree, and negative for every branch in B_{ix} or in a right-hand minor tree. If A_{2n} is not empty, then there must be a branch in A_{2n} whose signs in S_4 are positive for every branch belonging to a right-hand B_j minor tree, and negative for every branch in B_{ix} or in a left-hand

B_j minor tree. Naturally, if A_{21} is empty, then no left-hand B_j minor trees exist; similarly if A_{2n} is empty, no right-hand B_j minor trees exist. The converse does not follow. Each branch in B_{ix} must have all negative signs in S_3 and S_4 , and the converse: all rows through S_3 and S_4 with all signs in S_3 and S_4 negative must be a B_{ix} branch. This process separates Section B into three parts; a "central" minor tree B_i that is comprised of B_{ix} , B_{iv} , and b_b , the Section B minor trees to the left of B_i , and the Section B minor trees to the right of B_i .

Any row through S_3 and S_4 having a plus sign in S_3 and a plus sign in S_4 represents a contradiction and hence an unrealizable network. This row is simultaneously assigned to both left-hand and right-hand minor trees, an obvious impossibility.

At the conclusion of this step, matrix (20) becomes:

$$Y_s^{sc} = \begin{matrix} b_1 \\ b_n \\ A_1 \\ A_{21} \\ A_{2n} \\ A_n \\ B_i \\ B_{jL} \\ B_{jR} \end{matrix} \left(\begin{array}{cccccccccc} + & - & + & + & - & - & - & - & - & - \\ - & + & - & - & + & + & - & - & - & - \\ + & - & T_1 & P & N & N & N & N & N & N \\ + & - & P & P & N & N & N & S_3 & N & N \\ - & + & N & N & P & P & N & N & S_4 & N \\ - & + & N & N & P & T_n & N & N & N & N \\ - & - & N & N & N & N & T_i & N & N & N \\ - & - & N & S_3 & N & N & N & D_1 & N & N \\ - & - & N & N & S_4 & N & N & N & D_2 & N \end{array} \right) \quad (21)$$

where the new partitions have been drawn with heavy lines and T_i is the sign partition dealing exclusively with minor tree B_i .

2.34 B_j Minor Trees

In step 3, Section B was partitioned into three parts; a central minor tree B_i , a left-hand set of minor trees B_{jL} , and a right-hand set of minor trees B_{jR} . This fourth step consists of separating the minor trees in B_{jL} and B_{jR} . Each one of these minor trees is connected to the maximal tree through a unique node in the A_2 linear subtree. The B_{jL} minor trees are connected to nodes of the A_{21} linear subtree and the B_{jR} minor trees are connected to nodes of the A_{2n} linear subtree. To separate these minor trees, examine S_3 and S_4 in detail. In matrix (21) the columns through A_{21} and A_{2n} that have plus signs only for the rows through B_{jL} and B_{jR} respectively, have been placed in evidence next to the line dividing A_{21} from A_{2n} .

All the rows corresponding to the unique B_{jL} minor tree connected to a unique A_{21} node must have the same number of positive signs in S_3 . No other minor tree connected to a different node can have that same number of positive signs per row in S_3 .

All the rows corresponding to the unique B_{jR} minor tree connected to a unique A_{2n} node must have the same number of positive signs in S_4 . No other minor tree connected to a different node can have that same number of positive signs per row in S_4 .

These last two statements follow because each of the unique B_{jL} minor trees connects through a unique node in A_{21} and therefore all of each minor tree's regions are contained in a unique number of A_{21} regions (plus signs in S_3) and disjoint with all other A_{21} regions (minus signs in S_3). The same concept holds for B_{jR} minor trees, A_{2n} regions,

and S_4 . Thus the rows of B_{jL} and B_{jR} may be ordered according to the number of positive signs per row in S_3 and S_4 respectively (obviously this ordering can proceed according to the negative signs per row just as well) and partitions introduced to separate the sets of rows having the same sign per row distribution. This partitioning extends through D_1 and D_2 in matrix (21) such that the new diagonal partitions within D_1 and D_2 deal exclusively with each B_{jL} and B_{jR} minor tree. All of the new off diagonal partitions in D_1 and D_2 must be entirely negative if the matrix is unrealizable as to sign. This is shown in matrix (22).

The columns through S_3 and S_4 can also be ordered because any A_{21} columns through S_3 with the same number of plus signs in S_3 comprise a linear minor 2-tree. Also, any A_{2n} columns through S_4 with the same number of plus signs in S_4 comprise a linear minor 2-tree. This means that there are no B_j minor trees connected to the nodes that connect the branches of these linear minor 2-trees together. When the columns and rows of S_3 and S_4 have been ordered according to the above, all the positive and negative signs must be separated in the stepwise manner suggested in matrix (22). All the plus and minus signs in S_3 and S_4 must be completely separated in this stepwise manner or the network is unrealizable. In matrix (22), the B_{jL} minor trees have been labeled B_2, B_3, \dots, B_{i-1} and the B_{jR} minor trees have been labeled $B_{i+1}, B_{i+2}, \dots, B_n$ to conform with Figure 16. Correspondingly, the diagonal minor tree partitions are $T_2, T_3, \dots, T_{i-1}, T_{i+1}, \dots, T_n$.

Thus it is relatively easy to complete the partitioning of the sign matrix. To place the matrix in a master form, reverse the direction in which the b_1 and A_{21} chains were thrown by multiplying partitions b_1 and A_{21} by minus one, and rearrange the partitions to conform more vividly with Figure 19 resulting in Y_{MS}^{sc} in matrix (23). In Figure 19, Section A_2 is composed of branches $b_2, b_3, b_4, \dots, b_{n-1}$.

In Figure 19 we are viewing the general network tree as a combination of several minor trees attached to the nodes of a linear subtree. Branches b_1 and b_n specify the extreme branches in the linear subtree. Minor trees A_1 and A_n are attached to the extreme nodes of the linear subtree. Minor tree B_i is attached to some node between branches b_1 and b_n . Section B_{jR} contains the several minor trees attached to the linear subtree nodes lying between those that join A_1 and B_i to the linear subtree. Section B_{jL} contains the several minor trees attached to the linear subtree nodes lying between those that join A_n and B_i to the linear subtree. The reasons for viewing the general tree as pictured in Figure 19 are very logical. First, from the basic definition, between any two branches there is one unique linear subtree connecting these two branches. These two branches we have called b_1 and b_n , and the linear subtree is uniquely Section A_2 . All the remaining branches must exist as sets of trees connected only through A_2 . These sets we have called A_1, A_n , and B , where $B = B_2, B_3, \dots, B_n$.

Two points remain to be discussed. The first concerns the order of branches in the A_1, A_n , and B_i partitions, and the second concerns the order of linear minor tree branches appearing in the partitions. Although this ordering does not affect the criteria for realizability based

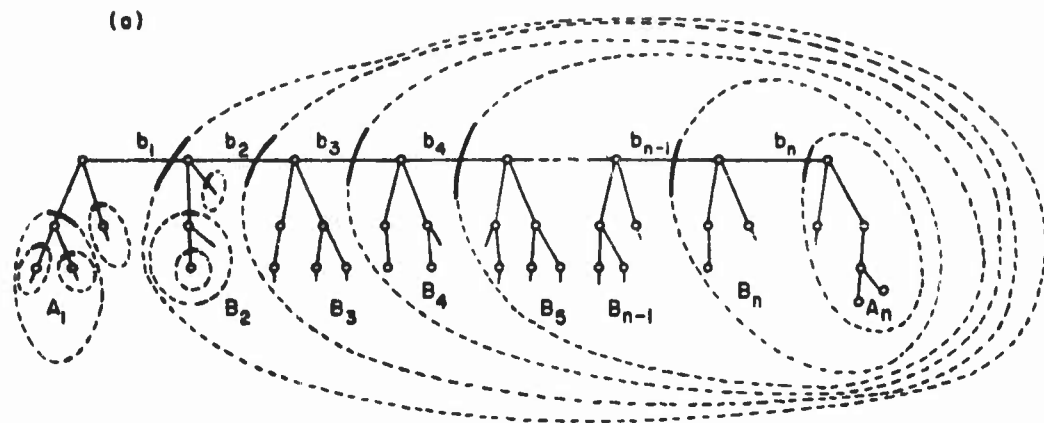

(b)

b_1	+	+	+	+	+	+	...	+	+	+	+	...	+	+	+	+	+	+	+	+				
b_2	+	+	+	+	+	+	...	-	-	+	+	+	+	...	+	+	+	+	+	+	+	+		
b_3	+	+	+	+	+	+	-	-	-	-	+	+	+	+	+	+	+	+			
b_4	+	+	+	+	+	+	+	+	+	+	+	+	+	+		
\vdots																								
b_n	+	+	+	+	+	+	+	+	+	+	+	+	+	+	
b_n	+	+	+	+	+	+	+	+	+	+	+	+	+	+
A_1	-	-	-	-	-	-	...	T_{A_1}	-	-	-	-	-	-	-	-	-	-	-	-	-	-	-	
B_2	-	-	-	-	-	-	...	-	T_{B_2}	-	-	-	-	-	-	-	-	-	-	-	-	-	-	
B_3	-	-	-	-	-	-	...	-	-	T_{B_3}	-	-	-	-	-	-	-	-	-	-	-	-	-	
B_4	-	-	-	-	-	-	...	-	-	-	T_{B_4}	-	-	-	-	-	-	-	-	-	-	-	-	
B_5	-	-	-	-	-	-	...	-	-	-	-	T_{B_5}	-	-	-	-	-	-	-	-	-	-	-	
\vdots																								
B_{n-1}	-	-	-	-	-	-	...	-	-	-	-	-	-	-	-	$T_{B_{n-1}}$	-	-	-	-	-	-	-	
B_n	-	-	-	-	-	-	...	-	-	-	-	-	-	-	-	-	T_{B_n}	-	-	-	-	-	-	
A_n	-	-	-	-	-	-	...	-	-	-	-	-	-	-	-	-	-	T_{A_n}	-	-	-	-	-	

Figure 19. (a) General Tree Form and (b) Matrix.

on the signs alone, it will prove indispensable for realizability as far as magnitude is concerned and for placing the network tree in more immediate evidence. First, it is desirable to order the branches in the diagonal minor tree partitions so that they comprise a miniature reproduction of the composite matrix Y_{MS}^{SC} , in which the first row in each diagonal partition, a branch like b_n , corresponds to the branch that attaches the minor tree to the node in the linear subtree composed of branches b_1 , A_2 , and b_n . This is very easily accomplished merely by treating the submatrix composed of the minor tree rows and the closest A_2 branch as the matrix to be ordered, with the A_2 branch taking the branch b_1 role. The closest A_2 branch in this case is either of the two vertical A_2 rows that define the step in the plus-minus staircase where the rows forming the minor tree comprise the landing

Secondly, it is desirable to order the A_2 branches such that the columns (and rows) read as the branches exist in the linear subtree. The only problem encountered is that of a linear minor 2-tree therein. A linear minor 2-tree is characterized by a set of rows indistinguishable in sign. To place them in proper order, it is necessary to revert to a study of magnitudes. If branches $i \dots k$ comprise a linear minor 2-tree within the A_2 linear subtree in order proceeding from branch b_1 to branch b_n , then

$$y_{ix} \supseteq \dots \supseteq y_{kx} \quad ,$$

and

$$y_{iy} \subseteq \dots \subseteq y_{ky} \quad ,$$

where b_x is any branch on any linear tree including branches $1 \dots k$ situated on the branch b_1 side of $1 \dots k$, and b_y is any branch on any linear subtree including branches $1 \dots k$ situated on the branch b_n side of $1 \dots k$.

A natural question that arises concerns the necessary number of partitions. If branches b_1 and b_n were discretely chosen such that they met at a common node, then the only nonempty partitions would be b_1 , b_n , A_1 , A_n , and the single minor tree B_1 . This is the most basic partitioning obtainable, and it is only obtainable through exercising discretion in choosing branches b_1 and b_n . This reduced matrix is, from matrix (22),

$$Y_{MS}^{sc} = \begin{bmatrix} b_1 & + & + & - & + & + \\ & + & + & - & - & + \\ & & - & - & T_{A1} & - \\ & & + & - & - & T_{Bi} \\ & & + & + & - & - & T_{An} \end{bmatrix} \quad (24)$$

This general reduction cannot be carried lower than five partitions, and there is only one way to reduce the matrix to five partitions. In matrix (24), rows b_1 , b_n , and B_1 specify all the remaining off-diagonal signs; here the only remaining sign is the A_1 , A_n entry. At this point it is interesting to compare matrix (24) with matrix (13). Note that the lowest order Y_s^{sc} that may be unrealizable is also five; e.g. the same order as the minimally reduced master sign matrix. If the trees A_1 , A_n , and B_1 in matrix (24) are reduced to single branches, the diagonal entries automatically become plus signs and the three reference branches b_1 , b_n ,

and $b_b = B_i$ specify the one remaining sign, which in matrix (13) has been changed to plus, thus rendering the matrix contrary to the master sign matrix and hence unrealizable.

2.4 Specification of Zero Entries

A careful analysis of the preceding material points out one of the characteristics that makes the complete short-circuit admittance matrix unique. The prominent characteristics, which, as we shall see, are absent in the complete open-circuit impedance matrix, are that the signs completely determine the network tree topology, and that each and every entry has an associated sign, even though the magnitude of the entry may be zero. Thus when an admittance matrix is presented with many unspecified entries, the correct signs of these entries should be determined first, and then limitations placed on their magnitudes. In other words, this realization problem has a very definite analysis phase of its own.

In rearranging a given matrix to conform with Y_{MS}^{sc} in matrix (23), the preceding procedure utilized only a fraction of the total number of possible signs. Only those signs that influenced the determination of the final partitions were used. Once these partitions were rigorously established, all signs were fixed. Thus the first step in sign assignment is to establish each and every row within a unique partition. This problem may be described as follows: In the determination of Y_{MS}^{sc} in matrix (23) and Figure 19 through the presence of "arbitrary" unspecified entries, the established signs may relegate a branch (row) to either Section B_3 or B_4 and yet be unable to specify exactly its unique assignment. To specify this row's unique position, it is necessary to examine the magnitude relationships

that may preclude its existing in B_3 or in B_4 . For example, if this ambiguous row is b_k and if $y_{kj} \subseteq y_{lm}$ does not hold for all j, l, m , where b_j and b_m are any branches in $B_5, B_6, \dots, B_n, A_n$, then b_k cannot belong to Section B_4 . Although formally requiring a very lengthy and tedious enumeration, such useful magnitude relationships become evident upon understanding of the preceding material.

Once the partitions are fixed, the network tree is determined and the realization of the physical elements proceeds in a straightforward manner. These elements may be obtained directly as shown in the first section of this chapter, or they may be obtained in an algorithmic fashion by transforming the matrix such that the new network tree is a star tree. As a star tree, each off-diagonal entry is the admittance of a single, unique branch. This method is perhaps more applicable to computer synthesis. Since the partitioned matrix presents the network tree in a perceptible algebraic manner, the matrix to transform it into a star-tree configuration is obvious.

2.5 Discussion

The preceding general synthesis method for RLC short-circuit admittance matrices is most useful for large-scale problem solution and computer synthesis. This method, with a different interpretation, also has been developed independently for resistive networks by Biorci and Civalleri.² Besides presenting an alternative interpretation and development of the general method, this synthesis is not restricted to single-element-kind networks but uses general RLC (excluding mutual inductance) networks. The inclusion of these three basic elements does not complicate

the problem as much as might be suspected. In some cases it may actually simplify matters since it forces a more articulate interpretation of quantities much of whose intrinsic nature is camouflaged in the single-element-kind discussion.

III. THE OPEN-CIRCUIT IMPEDANCE MATRIX

3.1 Analysis

The complete open-circuit impedance matrix is formulated to describe the response of a network to excitations in terms of a complete set of independent branch currents. This analysis is identical to the admittance analysis with the natural interchange of dual quantities. The independent tree branch voltages become the independent co-tree branch currents. The application of Kirchhoff's current law to a current region becomes the application of Kirchhoff's voltage law to a voltage circuit. In either procedure, the network is represented or modeled by its network graph. When the tree is specified, the elements of the co-tree, or chords, automatically define a complete set of independent branch currents. A branch orientation is assigned to each chord. A voltage circuit, which is defined by an independent branch, may traverse one and only one chord and thus the i^{th} circuit is uniquely specified by the assigned set of chords and specification of the i^{th} chord.

Consider the network graph of Figure 20 where the lines represent

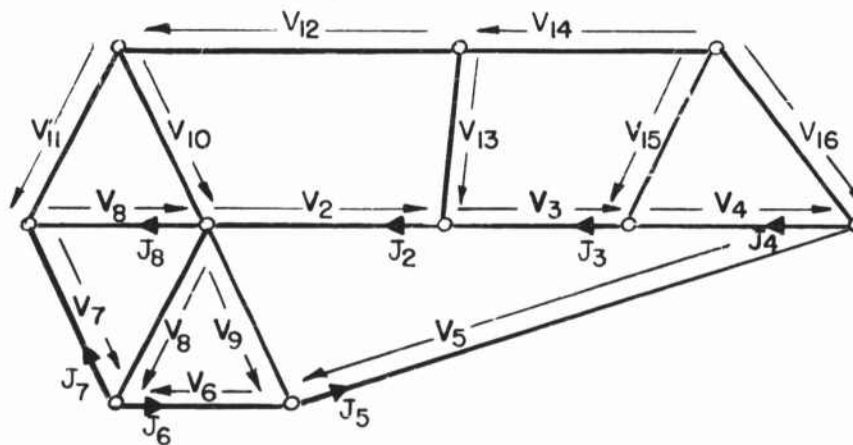

Figure 20. Example Network Graph with Independent Currents Based on Co-Tree.

generalized branches that are numbered and meet at the junctions or nodes. Assign branch voltage directions and select an arbitrary co-tree such as indicated in Figure 20. (For a particular branch, the direction of branch voltage rise is opposite to the direction of branch current flow.) The chord currents (that is, J_1, J_2, \dots, J_7) become the set of independent branch currents and appear in the final open-circuit impedance equations of the network.

The facts describing the network may be presented in the form of a Circuit Table. Let the orientation of a circuit proceed in the direction defined by the branch voltage of the independent branch. Then each entry in the Circuit Table is +1 if the branch voltage rise is in the direction of the circuit orientation, and -1 if it opposes the direction of the circuit orientation. As an example, consider the Circuit Table for Figure 20

Circuit Table

Circuit	Branch Numbers															
	1	2	3	4	5	6	7	8	9	10	11	12	13	14	15	16
1	1	0	0	0	0	0	0	0	0	-1	1	0	0	0	0	0
2	0	1	0	0	0	0	0	0	0	1	0	1	-1	0	0	0
3	0	0	1	0	0	0	0	0	0	0	0	0	1	1	-1	0
4	0	0	0	1	0	0	0	0	0	0	0	0	0	0	1	-1
5	0	0	0	0	1	0	0	0	-1	-1	0	1	0	-1	0	1
6	0	0	0	0	0	1	0	-1	0	0	0	0	0	0	0	0
7	0	0	0	0	0	0	1	-1	0	-1	-1	0	0	0	0	0

and z_i is the driving-point impedance in the i^{th} branch. Combining Equations (1) and (3) gives

$$v + E' = z(j + I') = z\beta_t J + zI' \quad (28)$$

Multiplying both sides by β and using relation (26) gives

$$\beta v + \beta E' = \beta E' = \beta z \beta_t J + \beta z I'$$

or

$$\beta E' - \beta z I' = \beta z \beta_t J$$

Since $\beta E' - \beta z I'$ replaces all excitations by voltage sources in the independent branches, it becomes

$$E = \beta z \beta_t J = Z^{\text{OC}} J \quad (29)$$

where

$$E = \begin{bmatrix} E_1 \\ E_2 \\ \cdot \\ \cdot \\ E_7 \end{bmatrix}$$

and where $\beta z \beta_t = Z^{\text{OC}}$ is the common complete open-circuit impedance matrix. Here Z^{OC} is called complete because it completely describes the response of the network in terms of the independent branch currents. It is called an open-circuit impedance matrix because the ij entry Z_{ij}^{OC} equals E_i/J_j with all $E_{k \neq i}$ assuming such values as are necessary to set all $J_{k \neq j} = 0$. When these conditions are fulfilled, all tree branches except the j^{th} branch may be open circuited without disturbing the state of the network

For a better understanding of these concepts, carefully examine the Circuit Table, Figure 20, and the impedance matrix Z^{oc} . This study involves the Z_{ij}^{oc} entry and shows the following:

1. Z_{ij}^{oc} is the unique sum of branch impedances z_k .
2. The several z_k appearing in the ij sum, Z_{ij}^{oc} , are the impedances of those branches common to both voltage circuits i and j .
3. The signs of the z_k comprising Z_{ij}^{oc} will be plus if the orientations of voltage circuits i and j are alike through branch b_k , and will be minus if the orientations of voltage circuits i and j are in opposition through branch b_k .
4. The Z_{ij}^{oc} entry is zero if voltage circuits i and j do not have a common branch voltage.
5. Since the circuits are based on a set of chords (and thus on a tree), all the several z_k comprising the sum Z_{ij}^{oc} will have the same sign.
6. If branch i is a co-tree branch, then z_i will appear only in the Z_{ii}^{oc} sum.

The conclusion drawn from the above is that given any network and a co-tree (and thus necessarily the branch source voltages and response currents), the open-circuit impedance matrix follows immediately. Note that orienting the tree branches has no effect on (1) the circuit orientation, (2) the matrix, and (3) this analysis.

A tree has many interesting properties that provide the necessary uniqueness along with the general approach. Here it is appropriate to give warning of a possible misconception. In the impedance analysis the network tree is a peculiar artifice. It must be used and considered cautiously because the voltage circuits form the paramount basis in impedance analysis

not the tree. The tree is used merely as a convenient and useful tool to prove many relationships. The tree, however, is secondary in importance to the co-tree. In this analysis, the co-tree defines the tree, rather than the reverse, which is the case in the admittance analysis. It is convenient to use the tree in the following discussion of circuits; however, one should not be misled as to its importance. Let a co-tree and its tree be selected. Although a large number of different trees exist in the network graph, each and every tree will conform to a general form shown in Figure 21. Select any two tree branches, b_1 and b_4 . These two branches together with their unique connecting tree path form a linear subtree. This linear subtree will be called the general linear subtree (for the selected two branches) to distinguish it from the several other linear subtrees existing in the tree.

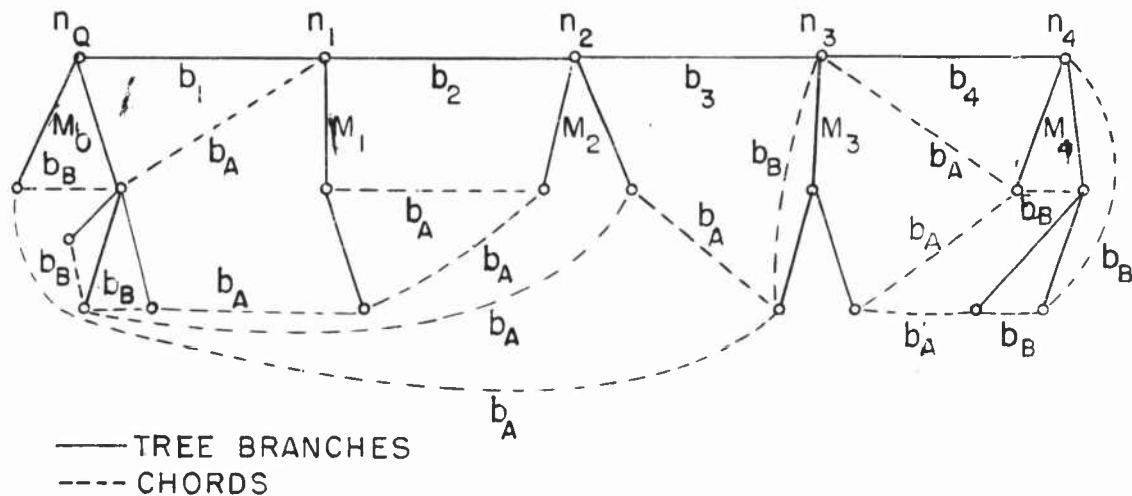

Figure 21. General Tree. General linear subtree = $n_0, b_1, n_1, b_2, n_2, b_3, n_3, b_4, n_4$; general minor trees = M_0, M_1, M_2, M_3 , and M_4 ; chords defining Type A circuits = b_A ; chords defining Type B circuits = b_B .

Let this general linear subtree have p branches. The remaining tree branches may be divided into $p + 1$ groups such that each group forms a minor tree connected to the whole by one of the $p + 1$ general linear subtree nodes. These minor trees are said to connect to the general linear subtree by their trunks; that is, those branches of a general minor tree that are incident on a node of the general linear subtree are the trunks of a general minor tree. Let the tree, in this general form, be drawn in a planar manner as indicated in Figure 21. Each of the remaining network graph branches, or chords, occupies a unique position specified by designating two nodes, which the chord connects, in the network tree. Each of these chords defines an independent branch current and voltage circuit that traverses that chord and some unique linear subtree within the general tree. Any circuit may be distinguished by designating it as:

Type A: A circuit that traverses a set of branches belonging to the general linear subtree, that is, its defining chord connects two different general minor trees.

Type B: A circuit that traverses no branch belonging to the general linear subtree.

In assigning orientations to the chords, it is convenient to adopt the convention of letting all Type A circuits traverse branches in the general linear subtree in the same direction. Now the matrix may be produced.

Each ij entry in the matrix contains information concerning the branches common to circuits i and j . If two circuits, i and j , have a linear subtree in common, then the magnitude of that ij entry is the sum of the impedances represented by that linear subtree. The sign of that entry is positive if the two circuits are in "phase" (same direction) through that

linear subtree, and negative otherwise. Note that if two Type A circuits traverse a common portion of the general linear subtree, the sign is positive. If two circuits have no linear subtree in common, then the entry is zero. Proceeding in this manner, the open-circuit impedance matrix can be written by inspection.

Before proceeding in the reverse direction (that is, obtain the network given a Z^{oc} matrix) it is worth while to take a close look at certain characteristics of a set of entries corresponding to a set of circuits. Let all the Type A circuits (Figure 21) traversing some portion of the general minor tree M_0 be numbered $1, 2, \dots, r$. Each ij entry in the open-circuit impedance matrix, $i, j \in (1, 2, \dots, r)$, is positive and bounded in magnitude from below by the impedance of branch b_1, z_{b_1} . If z_{b_1} is subtracted from all ij entries, $i, j \in (1, 2, \dots, r)$, the effect on the network in Figure 21 is to superimpose nodes n_1 and n_2 , that is, replace branch b_1 with a short circuit or zero impedance branch. In addition select any square partition Z_{pp}^{oc} of the open-circuit impedance matrix such that all the signs of Z_{pp}^{oc} are positive and such that if any of the remaining rows and corresponding columns are included in Z_{pp}^{oc} at least one zero or negative sign is simultaneously included. Then the circuits corresponding to the p rows and corresponding columns all traverse a common linear subtree. This statement will be proven in the theorems following. The concepts considered here are critical because they form the primary tools in building a network to conform with a given open-circuit impedance matrix, Z^{oc} . We now proceed to prove a number of lemmas and theorems concerning properties of the various types of circuits. These theorems will be used in developing realization techniques.

Let Z^{OC} be an impedance matrix based on the interaction of a set of independent circuits $\{\lambda\}$, defined by a set of chords $\{b_c\}$ that comprise a particular co-tree. For an LLFPB network, it is necessary that Z_{ij}^{OC} can be written,

$$Z_{ij}^{OC} = \pm \frac{\sum_{i=0}^n a_i s^i}{\sum_{j=0}^m b_j s^j},$$

where $a_i, b_j \geq 0$, and s is the complex frequency $\sigma + j\omega$. In other words all entries are driving-point impedances times ± 1 .

Lemma 1. Let Z_{ij}^{OC} be non-zero. Then circuits λ_i and λ_j traverse a common non-zero set of branches and all the branches that circuit λ_i and circuit λ_j have in common form a linear subtree.

Proof. By the definition of Z_{ij}^{OC} , circuits λ_i and λ_j have a non-zero set of branches in common. By the definition of a circuit, the only elements of a circuit available for intersection (interaction) with another circuit form a tree path that is by definition a linear subtree. Therefore, if Z_{ij}^{OC} is non-zero and all the elements that circuit λ_i and circuit λ_j have in common do not form a linear subtree, then they must form a set of two or more linear subtrees that are not connected. If this is true, then there are two different tree paths, one on λ_i and one on λ_j , that connect two different tree nodes, one of each of two of the sets of common linear subtrees, contrary to the definition of a tree.

Lemma 2. If Z_{ij}^{OC} is non-zero, then circuits λ_i and λ_j can be oriented such that the sign of z_{ij} is positive.

Proof: Assume Z_{ij}^{oc} is negative. Multiply row i and column j by -1 , thus reversing the orientation of circuit λ_i . Now the sign of Z_{ij}^{oc} is positive.

Lemma 3. Let $\{\lambda_1, \dots, \lambda_n\}$ be a set of n circuits that have the largest common non-zero linear subtree b_λ . Let each of the circuits $\{\lambda_1, \dots, \lambda_n\}$ be oriented such that all the signs of Z_{ij}^{oc} , where $\lambda_i, \lambda_j \in \{\lambda_1, \dots, \lambda_n\}$, are all positive. Then a circuit λ_p that traverses a non-zero portion of each of $\{\lambda_1, \dots, \lambda_n\}$ can be oriented such that the signs of Z_{ip}^{oc} , where $\lambda_i \in \{\lambda_1, \dots, \lambda_n\}$ are all positive, if and only if circuit λ_p traverses a non-zero portion of b_λ .

Proof: Let λ_p traverse a portion of b_λ . Adjust the orientation of λ_p such that Z_{1p}^{oc} has a positive sign. Then all Z_{ip}^{oc} , where $\lambda_i \in \{\lambda_1, \dots, \lambda_n\}$, are all positive. Let all Z_{ip}^{oc} , where $\lambda_i \in \{\lambda_1, \dots, \lambda_n\}$, have positive signs. Let λ_p be incident on λ_1 and immediately traverse a portion of a non-zero linear subtree. Then λ_p cannot cease traversing branches of λ_1 until after it has traversed a portion of all circuits in $\{\lambda_1, \dots, \lambda_n\}$, since to do so would imply either that Z_{ip}^{oc} is zero or has negative sign, where $\lambda_i \in \{\lambda_1, \dots, \lambda_n\}$, or that there is a closed path of tree branches. Since b_λ is the largest common linear subtree of the set of circuits $\{\lambda_1, \dots, \lambda_n\}$, then λ_p must pass through a non-zero portion of b_λ .

Theorem 1: Let $\{\lambda_1, \dots, \lambda_n\}$ be a set of n circuits. Then the circuits can be oriented such that all Z_{ij}^{oc} , where $\lambda_i, \lambda_j \in \{\lambda_1, \dots, \lambda_n\}$, have positive signs, if and only if all the circuits $\{\lambda_1, \dots, \lambda_n\}$ have a non-zero common linear subtree.

Proof: Immediately known from direct application of Lemmas 1, 2, and 3.

Definition: The set $\{\rho_a^\beta\}$ and the matrix $[\rho_a^\beta]$: Let a set of circuits $\{\lambda_a\}$ exist such that all Z_{ij}^{oc} are non-zero and such that all the signs of Z_{ij}^{oc} can be made positive simultaneously, where $\lambda_i, \lambda_j \in \{\lambda_a\}$. Let $\{\lambda_\beta\}$ be another set of circuits, not necessarily disjoint with λ_a . From the matrix Z^{oc} delete all rows and columns i , where λ_i is contained in $\{\lambda_\beta\}$ but not in $\{\lambda_a\}$. The set of circuits $\{\rho_a^\beta\}$ consists of the union of all circuits $\{\lambda_a\}$ with all circuits $\{\lambda_\gamma\}$, where the $\{\lambda_\gamma\}$ are taken from the remaining circuits in Z^{oc} that are not in $\{\lambda_a\}$ such that the following conditions hold:

1. Z_{ij}^{oc} is non-zero, where $\lambda_i, \lambda_j \in \{\rho_a^\beta\}$.
2. The signs of all Z_{ij}^{oc} can be made simultaneously positive, where $\lambda_i, \lambda_j \in \{\rho_a^\beta\}$.
3. If circuit $\lambda_k \notin \{\rho_a^\beta\}$ and the signs of Z_{ij}^{oc} are all positive, where $\lambda_i, \lambda_j \in \{\rho_a^\beta\}$, then either some Z_{ki}^{oc} is zero or the signs of Z_{ik}^{oc} are not all alike for all i , or both.

When no rows and columns are to be deleted in this process, then we say $\{\lambda_\beta\} = \phi =$ the empty set. The matrix $[\rho_a^\beta]$ is the partition of Z^{oc} such that the circuits pertaining to the rows and corresponding columns of $[\rho_a^\beta]$ exactly comprise $\{\rho_a^\beta\}$; that is $[\rho_a^\beta]$ is that partition of Z^{oc} , which describes only non-zero interactions among the circuits $\{\rho_a^\beta\}$. A particular entry in $[\rho_a^\beta]$ will be denoted by $[\rho_a^\beta]_{ij}$. Note that in general $\{\rho_a^\beta\}$ is not unique.

While this $\{\rho_a^\beta\}$ concept may seem a bit abstruse, it is very simple. The set of circuits $\{\lambda_a\}$ are seen to traverse a common, non-zero linear subtree. This common subtree is composed of $n \geq 1$ branches. Assume that there is only one branch in common, b_a , and that there is only one

other circuit, λ_γ that also traverses b_a and is not contained in $\{\lambda_a\}$; then $\{\rho_a^\beta\} = \{\lambda_a\} + \lambda_\gamma$. Now, assume that there are three branches in $b_a = b_1, b_2,$ and b_3 . Also, assume that there are sets of circuits not in $\{\lambda_a\}$; that is, $\{\lambda_{123}\}, \{\lambda_{12}\}, \{\lambda_{23}\}, \{\lambda_1\},$ and $\{\lambda_2\}$ that respectively traverse branches $b_1 b_2 b_3, b_1 b_2, b_2 b_3, b_1,$ and b_2 (see Figure 22). Then there are two unique sets $\{\rho_a^\beta\}$ as follows:

$$\{ {}_1\rho_a^\beta \} = \{ \lambda_a \} + \{ \lambda_{123} \} + \{ \lambda_{12} \} + \{ \lambda_1 \} \quad ,$$

$$\{ {}_2\rho_a^\beta \} = \{ \lambda_{123} \} + \{ \lambda_{23} \} + \{ \lambda_2 \} + \{ \lambda_{12} \} \quad .$$

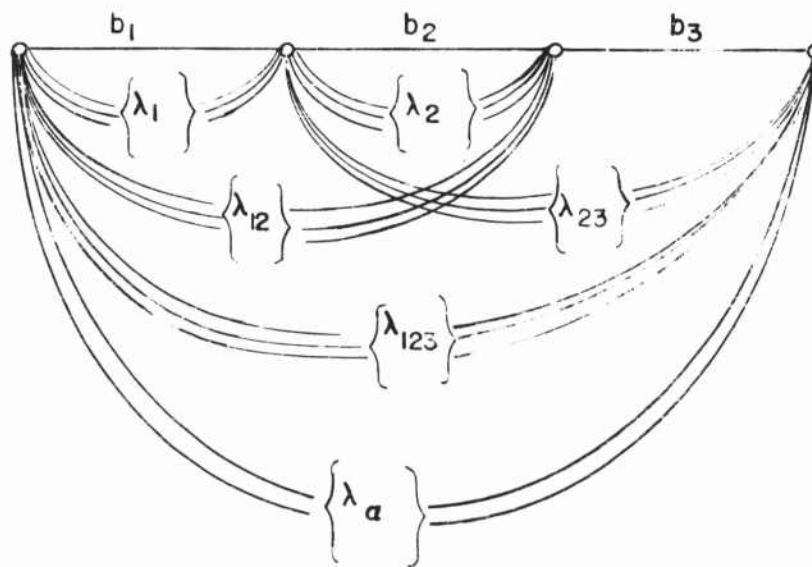

Figure 22. Example Circuits for $\{\rho_a^\beta\}$ Expansion.

For another example of this $\{\rho_a^\beta\}$ concept, let $\{\lambda_\beta\} = \phi$ and consider a matrix Z^{OC} . First, select a $\{\lambda_a\}$ set. Assume that the number of circuits in $\{\lambda_a\}$ is a . Let the rows and columns of Z^{OC} be rearranged such that the first a rows and columns exactly correspond to the set $\{\lambda_a\}$; that is, $\{\lambda_a\} = \{\lambda_1, \lambda_2, \dots, \lambda_a\}$. The only stipulation placed on a is that $a \geq 1$. The present state of Z^{OC} is shown in matrix (30).

$$Z^{OC} = \left[\begin{array}{c|cccc} \{\lambda_a\} & + & + & + & \dots & + \\ & + & + & + & \dots & + \\ & + & + & + & \dots & + \\ & \cdot & \cdot & \cdot & & \cdot \\ & \cdot & \cdot & \cdot & & \cdot \\ & \cdot & \cdot & \cdot & & \cdot \\ & + & + & + & \dots & + \\ \hline \lambda_1 & \text{all } + & & & & \\ \lambda_2 & \text{all } - & & & & \\ \lambda_3 & + \text{ and } - & & & & \\ \lambda_4 & +, -, \text{ and zero} & & & & \end{array} \right] \quad (30)$$

As shown in matrix (30), all the remaining rows not in $\{\lambda_a\}$ may be separated into four mutually exclusive groups: all rows i such that each Z_{ik}^{OC} is for

λ_1 : non-zero and has positive sign, where $k \in \{\lambda_a\}$;

λ_2 : non-zero and has negative sign, where $k \in \{\lambda_a\}$;

λ_3 : non-zero and such that at least one Z_{ik}^{OC} has positive sign and at least one Z_{ik}^{OC} has negative sign, where $k \in \{\lambda_a\}$;

λ_4 : zero, where $k \in \{\lambda_a\}$.

and thus

$$\bigcup_{i=1}^{\eta} \{i\lambda_Y\} = \{\lambda_Y\} \quad .$$

Note that for a given matrix, the set of expansions $\{i\rho_a^\phi\}$ is unique.

In the example of Figure 22 there are two unique expansions $\{1\rho_a^\beta\}$ and $\{2\rho_a^\beta\}$. Note that both expansions have circuits $\{\lambda_a\}$ and $\{\lambda_{123}\}$ in common. To describe expansions whose only common member is the defining set $\{\lambda_a\}$, the following extension is defined:

Definition: a proper α -set. Let there exist $n \geq 1$ unique expansions $\{i\rho_a^\beta\}$, where $i = 1, 2, \dots, n$. If $\bigcap_{i=1}^n \{i\rho_a^\beta\} = \{\lambda_a\}$, then $\{\lambda_a\}$ is a proper α -set.

Physically a proper α -set has definite significance. From the definition of $\{i\rho_a^\beta\}$, and thus $\{\lambda_a\}$ and also Lemma 3, there exists a unique non-zero linear subtree, say b_a , which is the largest and is traversed by all the circuits contained in $\{\lambda_a\}$. To say that $\{\lambda_a\}$ is a proper α -set is equivalent to saying that $\{\lambda_a\}$ includes each and every circuit that traverses b_a in its entirety.

Lemma 4: There are no circuits other than those possibly contained in $\{\lambda_\beta\}$ that are not contained in the set $\{i\rho_a^\beta\}$ and that traverse a portion of the largest linear subtree common to all the circuits $\{\lambda_a\}$.

Proof: Immediately known from Lemma 3 and the definition of $\{i\rho_a^\beta\}$.

Lemma 5: $[\rho_a^\beta]_{ij} = z_\rho + Z_{ij}^{(r)}$, where $Z_{ij}^{(r)}$ and z_ρ are driving-point impedances, and, in fact, z_ρ is the sum of the impedances in the largest linear subtree common to all circuits $\{i\rho_a^\beta\}$.

Theorem 2: There are λ_i and λ_j such that $[\rho_a^\beta]_{ij}$ is exactly the sum of the impedances and is the largest linear subtree that all circuits of the set $\{i\rho_a^\beta\}$ have in common.

Proof: Let Z_ρ be the sum of the impedances of the largest linear subtree having terminal nodes n_1 and n_2 common to all circuits $\{\rho_a^\beta\}$. Assume that λ_i and λ_j do not exist. Then by Lemma 5, each $[\rho_a^\beta] = z_\rho + z_{ij}^{(r)}$, where $z_{ij}^{(r)}$ is non-zero. Subtract z_ρ from all entries $[\rho_a^\beta]$ thus superimposing nodes n_1 and n_2 . Since all the remaining entries are positive, non-zero, there is another linear subtree common to all circuits contained in $\{\rho_a^\beta\}$ by Theorem 1; hence, a contradiction.

Lemma 6: Let the largest linear subtree common to the set of circuits $\{\lambda_a\}$ be a single tree branch b_a . Then $\{\rho_a^\beta\}$ is unique.

Proof: Assume that $\{\rho_a^\beta\}$ is not unique. Then there are at least two different sets, $\{\rho_a^\beta\}$ and $\{\rho_a^\beta\}$, where

$$\{\rho_a^\beta\} = \{\lambda_a\} + \{\lambda_{\gamma_1}\}$$

and

$$\{\rho_a^\beta\} = \{\lambda_a\} + \{\lambda_{\gamma_2}\}$$

By the assumption that $\{\lambda_{\gamma_1}\} \neq \{\lambda_{\gamma_2}\}$, there is $\lambda_{\gamma_1} \in \{\lambda_{\gamma_1}\}$ such that $\lambda_{\gamma_1} \notin \{\lambda_{\gamma_2}\}$. Since b_a is the only branch common to $\{\lambda_a\}$, then $\{\lambda_{\gamma_1}\}$ must circulate through b_a ; therefore, $\{\lambda_{\gamma_1}\} \in \{\rho_a^\beta\}$ and hence a contradiction.

Theorem 3: Let $\{\rho_a^\phi\}$ be unique; then the largest linear subtree traversed by all circuits $\{\rho_a^\phi\}$ is a single unique branch (Recall that ϕ is an empty set).

Proof: Call Z_a the largest linear subtree traversed by all circuits $\{\rho_a^\phi\}$. Assume that Z_a contains an interior node n_a . Let Z_a be the general linear subtree of the network; then a minor tree, M_a , is attached

to n_a . If no type A circuits traverse a non-zero portion of M_a , then the circuits within M_a comprise a separable part and thus M_a may be assumed to be attached to a terminal node of Z_a . If a type A circuit traverses a non-zero portion of M_a , then n_a is a terminal node of Z_a , hence a contradiction.

Corollary 1: Let $\{\rho_a^\phi\}$ be unique. Then there are λ_i and λ_j such that $\left[\rho_a^\phi\right]_{ij}$ is exactly the unique branch traversed by all circuits contained in $\{\rho_a^\phi\}$.

Corollary 2: There are λ_i and λ_j such that $\left[\rho_a^\phi\right]_{ij}$ is exactly a unique branch of the network tree.

Definition: A $\left[c_a^\beta\right]$ reduction. From each entry in the matrix partition $\left[\rho_a^\beta\right]$ subtract $\left[c_a^\beta\right]_{ij}$ where i, j are such that $\left[\rho_a^\beta\right]_{ij}$ is the sum of all impedances in the largest linear subtree common to all circuits, $\{\rho_a^\beta\}$. The effect of this reduction is to replace this largest linear subtree whose terminal nodes we will call n_1 and n_2 by a short circuit thus superimposing its terminal nodes n_1 and n_2 . If $\beta = \phi$, then "largest linear subtree" can be replaced by "unique tree branch".

The concept of a $\{\rho_a^\beta\}$ expansion and a $\left[c_a^\beta\right]$ reduction form the foundation for synthesizing a network with n circuits from a given n^{th} order open-circuit impedance matrix. In performing an expansion, all circuits having a common linear subtree are determined. In applying a reduction, the common branches are removed and the remaining matrix has its "unknowns" reduced by one. This dual process is repeated over and over until the synthesis is completed or until a contradiction is encountered that renders the matrix unrealizable or n circuits.

3.2 Realization of Z^{OC}

The following realization procedure constructs the network circuits

for a given open-circuit impedance matrix. It does not construct the circuits one by one, but instead progressively builds the dependent branches, or tree, thus gradually building all circuits more or less simultaneously. Briefly, it consists of four distinct phases. In the first phase, an arbitrary proper α -set of circuits is selected. The common linear subtree of this α -set then becomes the general linear subtree. All possible expansions $\{ \rho_{\alpha}^{\phi} \}$ yield the complete set of branches that make up the general linear subtree; therefore, at the conclusion of the first phase, all the branches of the general linear subtree are known and identified by the particular circuits that traverse each one. In the second phase, the branches of the general linear subtree are placed in their proper position. In general, the proper order is obtained immediately from the branch-circuit identifications found in phase one. It may, however, require information contained in the type B circuits to be certain of their proper order. Nevertheless, at the conclusion of the second phase, the general linear subtree is complete, and each type A circuit is identified by its two points of incidence with the general linear subtree. In the third phase, the minor tree branches and trunks that have two or more type A circuits traversing them are developed. In effect this completes the synthesis of all relations existing among type A circuits. Following this, the remaining circuits, type B, are grouped according to the minor tree through which each circulates. In phase four, the type B circuits are found by applying the preceding techniques to the general minor trees, thus completing the network. Like the admittance synthesis method, this procedure either terminates with the desired network or with a contradiction rendering the matrix unrealizable by n circuits defined by n independent branch currents.

When a given open circuit impedance matrix, Z^{OC} , is based on a tree, then that tree can be redrawn in several ways, each conforming to the general tree form. This realization develops the network tree and the graph from the matrix by means of successive applications of $\left[\rho_a^\beta \right]$ reductions. These applications successively develop a general tree form along with the manner of circuit interactions occurring within the general tree branches.

3.24 Phase 1

Let an open-circuit impedance matrix Z^{OC} be given. Reorder the rows and corresponding columns such that the first a rows and corresponding columns form a partition of all non-zero entries with positive signs. Let these first a circuits form a proper a -set. In general $\{\rho_a^\phi\}$ is not unique, however, if it is unique, let the common branch be the general linear subtree and proceed to Phase 3. If $\{\rho_a^\phi\}$ is not unique, let z_a denote the largest linear subtree common to all circuits λ_a . This linear subtree z_a will be produced branch by branch and will become the general linear subtree. This Phase 1 is concerned with producing all the individual branches that make up z_a .

Begin by determining all sets $\{\rho_a^\phi\}$ and call the i^{th} set $\{i\rho_a^\phi\} = \{\lambda_a\} + \{\lambda_i\}$. Each set $\{i\rho_a^\phi\}$ determines a single unique branch of the general linear subtree by Theorem 3, say z_i . Call the intersection of a set of the sets $\{\lambda_i\}, \{\lambda_i \cap j \cap \dots \cap k\}$. If $\lambda_p \in \{\lambda_i \cap j \cap \dots \cap k\}$, then λ_p traverses each of the unique branches z_i, z_j, \dots, z_k . Conversely, z_i, z_j, \dots, z_k are traversed by λ_p if and only if $\lambda_p \in \{\lambda_i \cap j \cap \dots \cap k\}$. Therefore, having determined the sets $\{i\rho_a^\beta\}$ and consequently z_i and $\{\lambda_i\}$, associate with each z_i all the circuits that traverse z_i .

To understand this process further, complete a $\left[{}_1\rho_a^\phi \right]$ reduction. As expected from the preceding discussion, this is accompanied by the appearance of zero entries in the $\left[{}_1\rho_a^\phi \right]$ partition. When such a zero appears in the ij entry of the $\left[{}_1\rho_a^\phi \right]$ partition, this obviously signifies that λ_i and λ_j have as their common linear subtree the single unique branch z_1 . Now, if there is a circuit $\lambda_k \in \{\lambda_1\}$, such that the only portion of the general linear subtree through which λ_k circulates is z_1 , then call such a circuit λ_{z_1} . The presence of a λ_{z_1} circuit is signaled by the appearance of zero in the ij entry, where $\lambda_j \in \{\lambda_1\}$ and $\lambda_i \in \{\lambda_a\}$. In general, if there is a $\lambda_j \in \{\lambda_1\}$ such that a zero appears in the ij entry with $\lambda_i \in \{\lambda_a\}$, then zeros will appear in all jk entries where $\lambda_k \in \{\lambda_a\}$. However, if zeros appear only in entries jk for $\lambda_j \in \{\lambda_1\}$ and all λ_k contained in a proper sub-set of $\{\lambda_a\}$, then z_1 must be an end branch of the general linear subtree z_a . This is true because only if z_1 is an end branch of the general linear subtree can a λ_{z_1} circuit have more than one branch in common with some $\lambda_k \in \{\lambda_a\}$. Let the set of λ_{z_1} circuits be called $\{\lambda_{z_1}\}$. Note that if $\lambda_k \in \{\lambda_{z_1}\}$ and if $\lambda_k \in \{\lambda_i\}$ for some $i \neq 1$, then this is a contradiction rendering the matrix unrealizable by a set of circuits based on co-trees. Since we know the accurate placement of all circuits in $\{\lambda_{z_1}\}$ in so far as z_a is concerned, e. g., through z_1 only, they will be ignored in the remainder of this initial synthesis phase. Note that at the conclusion of Phase 1, the set $\{\lambda_{z_1}\}$ is immediately known since z_1 is the only branch that associates and and all components of $\{\lambda_{z_1}\}$ with itself. Now, if a zero appears in the ij entry, where $\lambda_i, \lambda_j \in \{\lambda_1\}$, and all entries ik and jk , where $\lambda_k \in \{\lambda_a\}$, are not zero, then circuits λ_i and λ_j are left with no common linear subtree. However, they

both still circulate through a non-zero portion of the remaining general linear subtree. Consideration of this shows that all the circuits involved in the appearance of such zeros may be grouped into two sets such that for each set all the members have a non-zero portion of the remaining general linear subtree in common and such that no member of one set has any non-zero branch in common with any member of the other set. Call one of these two sets $\{\lambda_{1R}\}$ and the other set $\{\lambda_{1L}\}$. Call the remaining portion of $\{\lambda_1\}$, those circuits that are not involved with the appearance of any zeros, $\{\lambda_{1I,R}\}$. To clarify this selection by zero occurrence further, see matrix (32) and Figure 23, which together illustrate the occurrence of zeros following the $\left[\begin{smallmatrix} 1 \\ 1 \end{smallmatrix} \rho_a^\phi \right]$ reduction. Note that this illustration assumes that z_1 is not an end branch. If it were an end branch, then only $\{\lambda_{z_1}\}$ would be present together with either $\{\lambda_{1R}\}$ or $\{\lambda_{1L}\}$ but not both.

To continue this process, carry out a $\left[\begin{smallmatrix} 2 \\ 2 \end{smallmatrix} \rho_a^\phi \right]$ reduction. Once again, this reduction is accompanied by the appearance of zeros in the $\left[\begin{smallmatrix} 2 \\ 2 \end{smallmatrix} \rho_a^\phi \right]$ partition of Z^{OC} . The entrance of these zeros must now take into account the preceding reduction. This is a natural consequence of the possibly nonempty intersection $\{\lambda_1 \cap \lambda_2\}$. First determine if there are any λ_{z_2} loops, and if so, whether z_2 is an end branch of the general linear subtree. Recall that the existence of any λ_{z_2} circuits is signaled by the appearance of zeros in the ij entry, where $\lambda_j \in \{\lambda_c\}$, $\lambda_i \in \{\lambda_2\}$, and $\lambda_i \notin \{\lambda_2 \cap \lambda_k\}$ for all $k \neq 2$. Now, if any zeros appear in the ij entry where $\lambda_j \in \{\lambda_a\}$ and $\lambda_i \in \{\lambda_2 \cap \lambda_1\}$, then this signals the appearance of a $\lambda_{z_1 z_2}$ circuit, that is, a circuit that traverses the general linear subtree only through branches z_1 and z_2 and no other branch. Obviously, this means that z_1 and z_2 have a common node and may be drawn as such

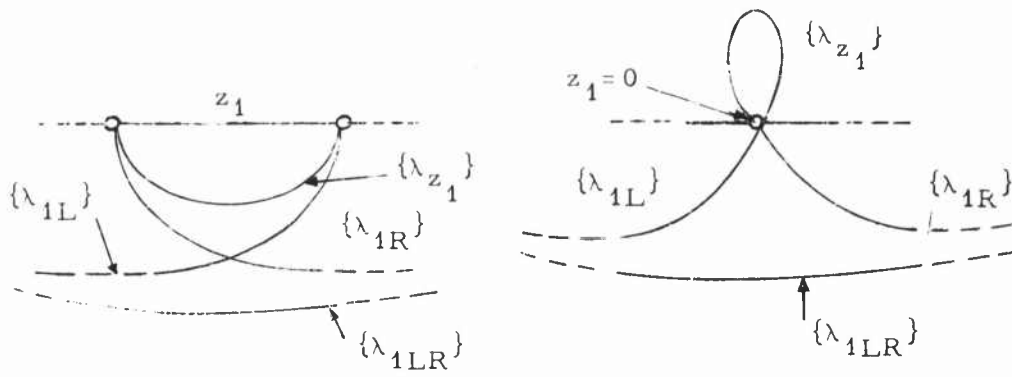

(a)

(b)

$$\left\{ \begin{array}{l} \{\lambda_a\} \\ \{\lambda_{1R}\} \\ \{\lambda_{1L}\} \\ \{\lambda_{1LR}\} \\ \{\lambda_{z_1}\} \end{array} \right\} \begin{bmatrix} + & + & + & + & 0 \\ + & + & 0 & + & 0 \\ + & 0 & + & + & 0 \\ + & + & + & + & 0 \\ 0 & 0 & 0 & 0 & \end{bmatrix} \quad (32)$$

Figure 23. Example of $\{\rho_a^\phi\}$ Reduction: (a) Before $\{ {}_1\rho_a^\phi \}$ Reduction, (b) After $\{ {}_1\rho_a^\phi \}$ Reduction [see matrix (32)].

along with $\{\lambda_{z_1}\}$, $\{\lambda_{z_2}\}$, and $\{\lambda_{z_1 z_2}\}$. The remaining circuits in $\{\lambda_2\}$ may be grouped in three sets, as was done for $\{\lambda_1\}$. These sets are $\{\lambda_{2R}\}$, $\{\lambda_{2L}\}$, and $\{\lambda_{2RL}\}$. By convention, these sets are to be labeled such that one of the following two intersections are empty, $\{\lambda_{1R}\} \cap \{\lambda_{2L}\}$ or $\{\lambda_{1L}\} \cap \{\lambda_{2R}\}$. Note once again that at the conclusion of Phase 1, the set $\{\lambda_{z_1 z_2}\}$ is immediately known since z_1 and z_2 are the only two branches that associate any component of $\{\lambda_{z_1 z_2}\}$ with themselves, and both z_1 and z_2 associate all components of $\{\lambda_{z_1 z_2}\}$ with themselves.

Continuing in this manner, consider the $\left[\begin{smallmatrix} \rho \\ i \end{smallmatrix} \beta \right]$ reduction. Again, this reduction is accompanied by the appearance of new zero entries in the $\left[\begin{smallmatrix} \rho \\ i \end{smallmatrix} \beta \right]$ partition of Z . The rows of this partition can be ordered such that the partition takes the form shown in matrix (32), where $\{\lambda_{1R}\} = \{\lambda_{iR}\}$, $\{\lambda_{1L}\} = \{\lambda_{iL}\}$, and $\{\lambda_{z_1}\} = \{\lambda'_{z_1}\}$. In order to take into account all of the preceding reductions, $\{\lambda'_{z_1}\}$ is subdivided into

$$\begin{aligned} & \{\lambda'_{z_1}\}, \quad \{\lambda'_{z_1 z_1}\}, \quad \{\lambda'_{z_1 z_2}\}, \quad \{\lambda'_{z_1 z_3}\}, \quad \dots, \\ & \{\lambda'_{z_1 z_1 z_2}\}, \quad \{\lambda'_{z_1 z_1 z_3}\}, \quad \dots, \quad \{\lambda'_{z_1 z_1 z_2 z_3}\}, \quad \dots \end{aligned}$$

These are sets of circuits that traverse the general linear subtree only through branches b_1, b_i and b_1, b_i and b_1, b_i and b_2, b_i and b_3, \dots, b_1, b_1 and b_2, b_1, b_1 and $b_3, \dots, b_1, b_1, b_2$ and b_3 and so forth respectively. These are determined by viewing the circuits as members of the possibly nonempty intersections $\{\lambda_i \cap 1\}, \{\lambda_i \cap 2\}, \{\lambda_i \cap 3\}, \dots, \{\lambda_i \cap 1 \cap 2\}, \{\lambda_i \cap 1 \cap 3\}, \dots, \{\lambda_i \cap 1 \cap 2 \cap 3\}, \dots$, and so forth respectively. To

review what is being done, it is worth while to look at the physical interpretation of what is happening. When $\left[{}_1\rho_a^\phi \right]$ is reduced, z_1 is reduced to a node as shown in Figure 23. This leaves four types of circuits in $\left[{}_1\rho_a^\phi \right]$. After each of the succeeding reductions, there are also four types of circuits in $\left[{}_i\rho_a^\phi \right]$. It is necessary, however, to distinguish between the self-circuit and sling type in order to position the branches properly within the general linear subtree. It is the nonempty intersection (and hence the timely occurrence of a zero) that determines the relative positions of the branches.

This first phase in the synthesis continues until all the $\left[{}_i\rho_a^\beta \right]$ have been reduced. When this has been done, if $\sum_i z_i = z_a$, then we proceed to the second phase. In this case, at the conclusion of Phase 1 all ij entries will be zero for all $\lambda_i \in \{\lambda_k\}$ and some $\lambda_j \in \{\lambda_a\}$. This indicates that no remaining circuits traverse a non-zero portion of the general linear subtree. If, however, $\sum_i z_i \neq z_a$, then some branches of the general linear subtree remain to be determined. This determination is accomplished by forming anew the $\left\{ {}_i\rho_a^\phi \right\}$ sets from what remains of the reduced Z matrix, and then repeating the foregoing procedure. When it is no longer possible to form a $\left\{ \rho_a^\phi \right\}$ set, and yet the circuits $\{\lambda_a\}$ still comprise a proper a -set, then the largest remaining linear subtree common to all circuits $\{\lambda_a\}$ is itself the last branch in the general linear subtree. This is the conclusion of Phase 1. All the branches in the general linear subtree and all type A circuits have been obtained. Not only have they been obtained, however, but in addition, their relative placement is, to a great extent, determined by the manner in which the type A circuits are associated with the branches. Specifically, what has been obtained is the totality of general

linear subtree branches with each branch identified by the totality of type A circuits that traverse that branch.

Briefly, Phase 1 is as follows:

1. Select a proper α -set in the given Z^{OC} matrix.
2. Form $\{i\rho_a^\phi\} = \{\lambda_a\} + \{\lambda_i\}$ from Z^{OC} , where $i = 1, 2, \dots, \eta$.
3. Associate with z_i each circuit that traverses z_i .
4. Reduce $[i\rho_a^\phi]$ for all i , where $i = 1, 2, \dots, \eta$.
5. Call $Z^{OC'}$ that matrix resulting when reductions have been applied to Z^{OC} .
6. Based on the same α -set, form $\{k\rho_a^\phi\}$ within $Z^{OC'}$, where $k = \eta + 1, \eta + 2, \dots, \eta + \mu$.
7. Associate with z_k each circuit that traverses z_k .
8. Continue until λ_a is no longer a proper α -set, and then call the final reduced matrix Z^{OC^r} .

3.22 Phase 2

In this phase the proper position of all branches Z_i that make up the general linear subtree, Z_a , will be determined. By doing this, the two incident points of each type A circuit on the general linear subtree will become evident simultaneously. At the conclusion of Phase 1, each branch of the general linear subtree has associated with it all the type A circuits that traverse it. This information, by itself, is normally sufficient to order the branches. Let Z_a be composed by n branches, Z_i . First, order the branches such that it is possible for each to be traversed by its associated circuits. Where it would be possible for a branch to take two or more positions, divide the branch into the necessary number of parts to

retain all possibilities. This places in evidence all information regarding the traversing of the type A circuits through the general linear subtree. Next, it is necessary to place in evidence the interactions between type A circuits exterior to the general linear subtree. Note here that if $Z_{ij}^{oc r}$ is non-zero, where $\lambda_i, \lambda_j \in \{\lambda_a\} + \bigcup_{i=1}^n \{\lambda_i\}$, $i \neq j$, then circuits λ_i and λ_j are incident on the general linear subtree at a common node. Remove such redundancies from the branch ordering to conform with this information. Finally, it is necessary to place in evidence the secondary interactions between type A circuits exterior to the general linear subtree. Therefore, express as a direct sum of matrices that partition of $Z^{oc r}$ whose rows and corresponding columns comprise all type B circuits. In effect, this reorders those rows and corresponding columns in the type B partition of $Z^{oc r}$, and subpartitions it so that all the entries of off-diagonal partitions are zero. Each of those subpartitions is a minor tree or section of it. Call these partitions $[{}_i \lambda_M]$ and the corresponding circuits $\{\lambda_M\}$. If $Z_{ij}^{oc r}$ and $Z_{kl}^{oc r}$ are non-zero, where λ_i and λ_k are type A circuits, and where λ_j and λ_l are both members of the same set $\{\lambda_M\}$, then circuits λ_i and λ_k are incident on the general linear subtree at the same node. With this information, the type A circuits are conclusively specified. At the end of this step, however, branches in the general linear subtree may still appear redundant. Such redundant branches may be erased at will, as the unique placement of those remaining branches is immaterial in the original Z matrix.

Thus the two points of incidence of each type A circuit on the general linear subtree have been specified. Simultaneously all the branches of Z_a have been properly ordered. In addition the minor trees and/or their sections

have been placed in evidence by the subpartitions $\left[\begin{smallmatrix} \lambda \\ i \\ M \end{smallmatrix} \right]$. Briefly, Phase 2 is as follows:

1. Order the branches in as general a manner as possible so that their placement allows the proper traversing of their associated circuits.
2. Use direct interaction among type A circuits exterior to the general linear subtree to remove part of the redundancy introduced in step 1.
3. Use secondary interaction among type A circuits within the minor trees to remove more of the redundancy.
4. Arbitrarily remove all remaining redundancy.

3.23 Phase 3

An example of the network at the conclusion of Phase 2 is presented in Figure 24a. In this phase the remaining specification of type A circuits as illustrated in Figure 24b is to be completed. This will involve definite specification of most circuits as well as some indefinite redundant specification that will be corrected in Phase 4. Indefinite redundant specification arises when two type A circuits are incident to the same two nodes and interact outside of the general linear subtree. In this case, it may be impossible to determine how much of the common "trunk" branch is at one incidence node and how much is at the other incidence node without examining type B circuits. To complete this specification of type A circuits, the off-diagonal terms in the $\{\lambda_a\}$ and $\left(\begin{smallmatrix} n \\ i=1 \end{smallmatrix} \right) \{\lambda_i\}$ partition of $Z^{oc r}$ will be used.

Let circuits λ_i and λ_j have a single common node of incidence on the general linear subtree at n_{ij} . Then $Z_{ij}^{oc r}$ is a trunk attached to

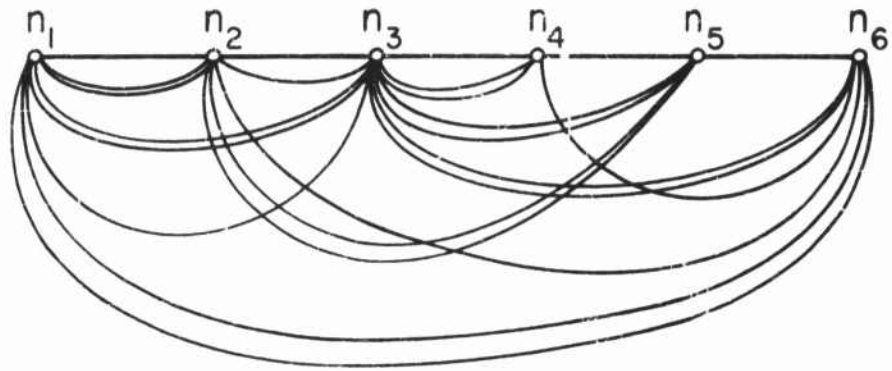

(a)

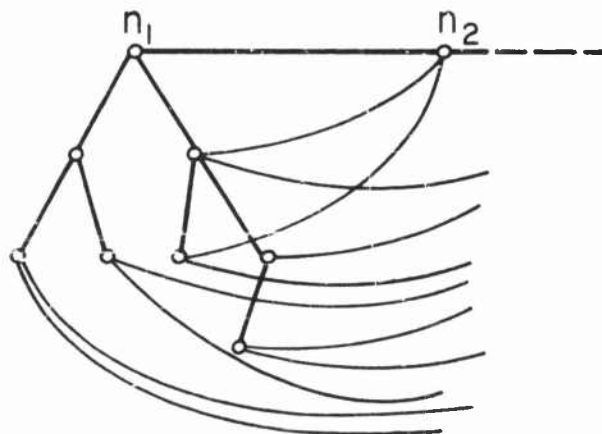

(b)

Figure 24. Final Phases of Complete Specification of Type A Circuits.

node n_{ij} , which both λ_i and λ_j traverse. Generalizing this concept, if $Z_{ij}^{oc^r}$ is non-zero, and if λ_i and λ_j each have an incidence node different from those of the other, then add that branch to the network. When all such $Z_{ij}^{oc^r}$ are operated on in this manner, the only remaining non-zero $Z_{ij}^{oc^r}$ will be those for circuits λ_i and λ_j traveling in parallel with each other. For such remaining entries, divide the branch into parts, placing one part at each of the two common incidence nodes. This places all type A circuits in their most general proper position relative to each other and completes their synthesis in so far as their interactions among themselves are concerned. Briefly, Phase 3 transfers the information from off-diagonal entries $Z_{ij}^{oc^r}$ to the network. Note that, in effect, this is merely another $\{\rho_a^\beta\}$ expansion and $[\rho_a^\beta]$ reduction, where a is now the trunk of a minor tree section, and $\{\lambda_\beta\}$ is a set of type B circuits.

3.24 Phase 4

In Phase 2 the subpartitions $[\lambda_M]$ were developed. Each of these partitions relates interactions among type B circuits within a particular minor tree. In this phase each minor tree section is developed by considering the branches added in Phase 3 as general linear subtrees and applying $\{\rho_a^\phi\}$ expansion-reduction techniques to uncover all circuits traversing them. Continuing in this fashion, the network is completely realized, or shown to be unrealizable.

This is but one procedure that uses the $\{\rho_a^\beta\}$ technique. Many variations will occur to the reader as he becomes familiar with the method. As an example of the preceding, consider matrix (33):

$$Z^{oc} = \begin{bmatrix} 8 & 5 & 2 & 1 & 1 & 1 & 3 & 1 & 0 & 1 \\ 5 & 8 & 4 & 1 & 1 & 3 & 3 & -2 & 0 & 3 \\ 2 & 4 & 9 & 3 & 1 & 3 & -2 & -2 & 0 & 3 \\ 1 & 1 & 3 & 5 & 3 & -2 & -2 & 0 & -2 & 0 \\ 1 & 1 & 1 & 3 & 4 & -2 & 0 & 0 & -2 & 0 \\ 1 & 3 & 3 & -2 & -2 & 6 & 0 & -2 & 2 & 3 \\ 3 & 3 & -2 & -2 & 0 & 0 & 10 & 0 & 0 & 0 \\ 1 & -2 & -2 & 0 & 0 & -2 & 0 & 8 & 0 & -2 \\ 0 & 0 & 0 & -2 & -2 & 2 & 0 & 0 & 6 & -2 \\ 1 & 3 & 3 & 0 & 0 & 3 & 0 & -2 & -2 & 8 \end{bmatrix} \quad (33)$$

Let λ_1 and λ_2 be the set $\{\lambda_u\}$. By inspection, the expansions are

$$\left. \begin{aligned} \{1\rho_a^\phi\} &= \lambda_1, \lambda_2, \lambda_7 \rightarrow Z_1 \\ \{2\rho_a^\phi\} &= \lambda_1, \lambda_2, \lambda_3, \lambda_4, \lambda_5 \rightarrow Z_2 \\ \{3\rho_a^\phi\} &= \lambda_1, \lambda_2, \lambda_3, \lambda_6, \lambda_{10} \rightarrow Z_3 \end{aligned} \right\} \quad (34)$$

It is therefore immediately known that λ_1, λ_2 comprise a proper α -set.

In addition it is immediately known that the circuits traversing Z_1 and Z_2 are only λ_1 and λ_2 ; that the circuits traversing Z_2 and Z_3 are λ_1, λ_2 , and λ_3 ; and that the circuits traversing Z_1 and Z_3 are only λ_1 and λ_2 .

The branches are given by

$$\begin{aligned} Z_1 &= Z_{17}^{oc} = Z_{27}^{oc} = 3 \\ Z_2 &= Z_{14}^{oc} = Z_{24}^{oc} = \dots = 1 \\ Z_3 &= Z_{16}^{oc} = Z_{1,10}^{oc} = 1 \end{aligned} \quad (35)$$

Removing Z_1 , Z_2 , and Z_3 from Z^{oc} , proceed as follows:

$$Z^{oc} \xrightarrow{\text{remove } Z_1} \begin{bmatrix} 5 & 2 & 2 & 1 & 1 & 1 & 0 & 1 & 0 & 1 \\ 2 & 5 & 4 & 1 & 1 & 3 & 0 & -2 & 0 & 3 \\ 2 & 4 & 9 & 3 & 1 & 3 & -2 & -2 & 0 & 3 \\ 1 & 1 & 3 & 5 & 3 & -2 & -2 & 0 & -2 & 0 \\ 1 & 1 & 1 & 3 & 4 & -2 & 0 & 0 & -2 & 0 \\ 1 & 3 & 3 & -2 & -2 & 6 & 0 & -2 & 2 & 3 \\ 0 & 0 & -2 & -2 & 0 & 0 & 7 & 0 & 0 & 0 \\ 1 & -2 & -2 & 0 & 0 & -2 & 0 & 8 & 0 & -2 \\ 0 & 0 & 0 & -2 & -2 & 2 & 0 & 0 & 6 & -2 \\ 1 & 3 & 3 & 0 & 0 & 3 & 0 & -2 & -2 & 8 \end{bmatrix}$$

$$\xrightarrow{\text{remove } Z_2} \begin{bmatrix} 4 & 1 & 1 & 0 & 0 & 1 & 0 & 1 & 0 & 1 \\ 1 & 4 & 3 & 0 & 0 & 3 & 0 & -2 & 0 & 3 \\ 1 & 3 & 8 & 2 & 0 & 3 & -2 & -2 & 0 & 3 \\ 0 & 0 & 2 & 4 & 2 & -2 & -2 & 0 & -2 & 0 \\ 0 & 0 & 0 & 2 & 3 & -2 & 0 & 0 & -2 & 0 \\ 1 & 3 & 3 & -2 & -2 & 6 & 0 & -2 & 2 & 3 \\ 0 & 0 & -2 & -2 & 0 & 0 & 7 & 0 & 0 & 0 \\ 1 & -2 & -2 & 0 & 0 & -2 & 0 & 8 & 0 & -2 \\ 0 & 0 & 0 & -2 & -2 & 2 & 0 & 0 & 6 & -2 \\ 1 & 3 & 3 & 0 & 0 & 3 & 0 & -2 & -2 & 8 \end{bmatrix}$$

$$\xrightarrow{\text{remove } Z_3} \begin{bmatrix} 3 & 0 & 0 & 0 & 0 & 0 & 0 & 1 & 0 & 0 \\ 0 & 3 & 2 & 0 & 0 & 2 & 0 & -2 & 0 & 1 \\ 0 & 2 & 7 & 2 & 0 & 2 & -2 & -2 & 0 & 2 \\ 0 & 0 & 2 & 4 & 2 & -2 & -2 & 0 & -2 & 0 \\ 0 & 0 & 0 & 2 & 3 & -2 & 0 & 0 & -2 & 0 \\ 0 & 2 & 2 & -2 & -2 & 5 & 0 & -2 & 2 & 2 \\ 0 & 0 & -2 & -2 & 0 & 0 & 7 & 0 & 0 & 0 \\ 1 & -2 & -2 & 0 & 0 & -2 & 0 & 8 & 0 & -2 \\ 0 & 0 & 0 & -2 & -2 & 2 & 0 & 0 & 6 & -2 \\ 0 & 2 & 2 & 0 & 0 & 2 & 0 & -2 & -2 & 7 \end{bmatrix} = Z^{oc^r} \quad (36)$$

In line with branch circuit identifications, the only possible branch orderings are shown in Figure 25a. Next since $Z_{47}^{oc^r}$ is non-zero, and λ_4 and λ_7 have no portion of Z_a in common, branch b_1 and b_2 must have a common node. This concludes Phase 1 and 2, with the resulting structure pictured in Figure 25b. Next, examine the entries in Z^{oc^r} pertinent to type A circuits. This information is transferred from matrix (36) to matrix (37):

$$\begin{array}{l}
 1 \\
 2 \\
 3 \\
 4 \\
 5 \\
 6 \\
 7 \\
 10
 \end{array}
 \begin{bmatrix}
 3 & 0 & 0 & 0 & 0 & 0 & 0 & 0 \\
 0 & 3 & 2 & 0 & 0 & 2 & 0 & 2 \\
 0 & 2 & 7 & 2 & 0 & 2 & -2 & 2 \\
 0 & 0 & 2 & 4 & 2 & -2 & -2 & 0 \\
 0 & 0 & 0 & 2 & 3 & -2 & 0 & 0 \\
 0 & 2 & 2 & -2 & -2 & 5 & 0 & 2 \\
 0 & 0 & -2 & -2 & 0 & 0 & 7 & 0 \\
 0 & 2 & 2 & 0 & 0 & 2 & 0 & 7
 \end{bmatrix}
 \quad (37)$$

Examining matrix (37) shows that:

1. λ_4 interacts with no type A loops off Z_a ;
2. $\lambda_3, \lambda_4, \lambda_7$ form a proper a-set;
3. $\lambda_6, \lambda_5, \lambda_4$ form a proper a-set; and
4. $\lambda_{10}, \lambda_6, \lambda_3, \lambda_2$ form a proper a-set.

This information yields Figure 25c. To finish the synthesis, return to matrix (36) and treat the minor tree trunks as was done in Phase 1 and Phase 2. This was done by expanding around each trunk as follows:

Step 1:

$$\left\{ \rho \lambda_{10}^\phi, \lambda_6, \lambda_3, \lambda_2 \right\} = \lambda_{10}, \lambda_6, \lambda_3, \lambda_2, \lambda_8 \rightarrow Z_4 = Z_{23}^{oc^r} = 2 \quad (38)$$

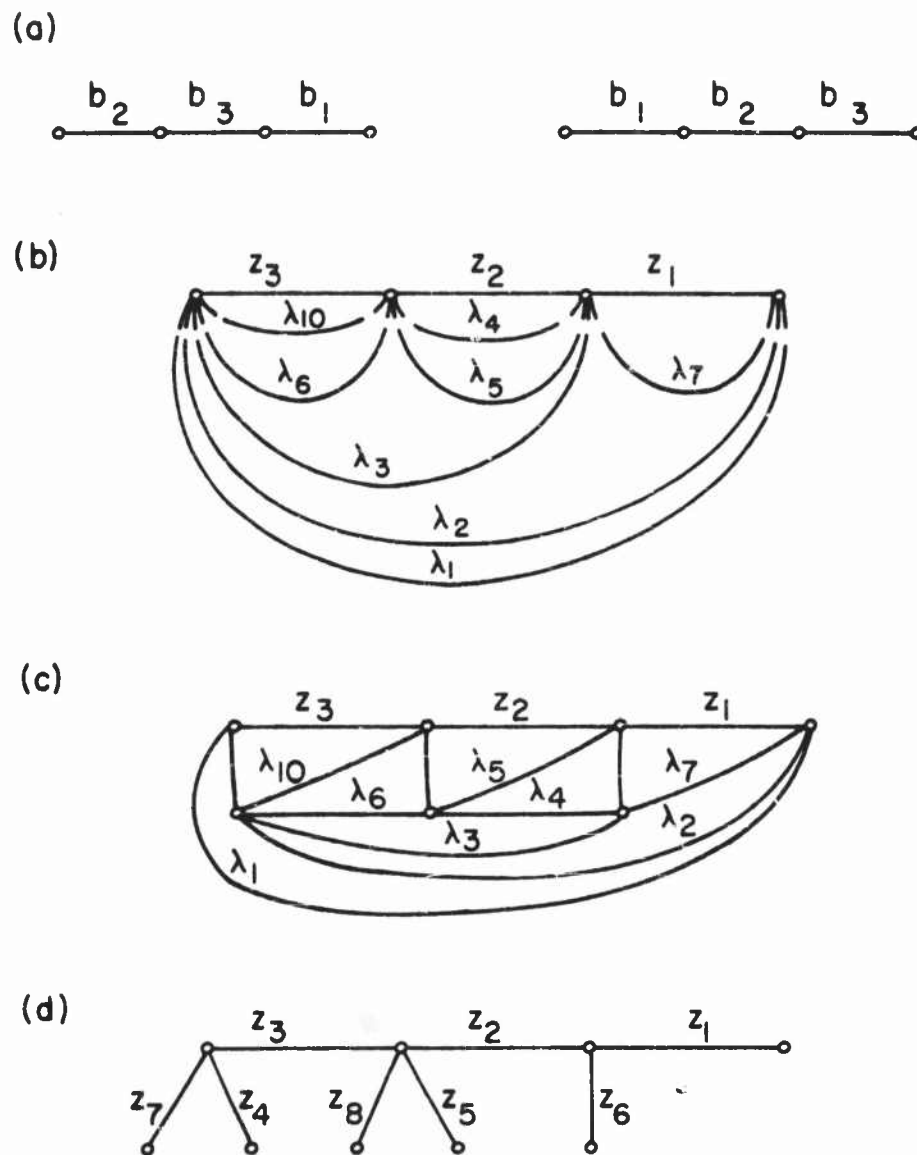

Figure 25. Realization of Matrix (33). (a) Possible Order at End of Phase 1. (b) Structure at End of Phase 2 (c) Structure at End of Phase 3. (d) Structure with All Trunks Developed.

$$z_1 = 3, \quad z_2 = 1, \quad z_3 = 1, \quad z_4 = 2,$$

$$z_5 = 2, \quad z_6 = 2, \quad z_7 = 1, \quad z_8 = 2,$$

Thus remove Z_4 from matrix (36), yielding matrix (39):

$$Z^{oc^r} \xrightarrow{\text{remove } Z_4} \begin{bmatrix} 3 & 0 & 0 & 0 & 0 & 0 & 0 & 1 & 0 & 0 \\ 0 & 1 & 0 & 0 & 0 & 0 & 0 & 0 & 0 & 0 \\ 0 & 0 & 5 & 2 & 0 & 0 & -2 & 0 & 0 & 0 \\ 0 & 0 & 2 & 4 & 2 & -2 & -2 & 0 & -2 & 0 \\ 0 & 0 & 0 & 2 & 3 & -2 & 0 & 0 & -2 & 0 \\ 0 & 0 & 0 & -2 & -2 & 3 & 0 & 0 & 2 & 0 \\ 0 & 0 & -2 & -2 & 0 & 0 & 7 & 0 & 0 & 0 \\ 1 & 0 & 0 & 0 & 0 & 0 & 0 & 6 & 0 & 0 \\ 0 & 0 & 0 & -2 & -2 & 2 & 0 & 0 & 6 & -2 \\ 0 & 0 & 0 & 0 & 0 & 0 & 0 & 0 & -2 & 5 \end{bmatrix} \quad (39)$$

Step 2:

$$\left\{ \rho \lambda_6^\phi, \lambda_5, \lambda_4 \right\} = \lambda_4, \lambda_5, \lambda_6, \lambda_9 \rightarrow Z_5 = Z_{45}^{oc^r} = 2 \quad (40)$$

Thus remove Z_5 from matrix (39), yielding matrix (41):

$$Z^{oc^r} \xrightarrow{\text{remove } Z_4, Z_5} \begin{bmatrix} 3 & 0 & 0 & 0 & 0 & 0 & 0 & 1 & 0 & 0 \\ 0 & 1 & 0 & 0 & 0 & 0 & 0 & 0 & 0 & 0 \\ 0 & 0 & 5 & 2 & 0 & 0 & -2 & 0 & 0 & 0 \\ 0 & 0 & 2 & 2 & 0 & 0 & -2 & 0 & 0 & 0 \\ 0 & 0 & 0 & 0 & 1 & 0 & 0 & 0 & 0 & 0 \\ 0 & 0 & 0 & 0 & 0 & 1 & 0 & 0 & 0 & 0 \\ 0 & 0 & -2 & -2 & 0 & 0 & 7 & 0 & 0 & 0 \\ 1 & 0 & 0 & 0 & 0 & 0 & 0 & 6 & 0 & 0 \\ 0 & 0 & 0 & 0 & 0 & 0 & 0 & 0 & 3 & -2 \\ 0 & 0 & 0 & 0 & 0 & 0 & 0 & 0 & -2 & 5 \end{bmatrix} \quad (41)$$

Step 3:

$$\left\{ \rho \lambda_3^\phi, \lambda_4, \lambda_7 \right\} = \lambda_3, \lambda_4, \lambda_7 \rightarrow Z_6 \rightarrow Z_{34}^{oc^r} = Z \quad (42)$$

3.3 Specification of Arbitrary Entries

In the Y^{SC} realization procedure, the question of arbitrary specification was dealt with in a straightforward manner. Here, for the Z^{OC} realization, the problem is at present not as clear cut. Not only is there a question of sign and magnitude as before, but in addition there is the sign-less zero entry to be specified. As in the admittance case, the realization of a portion of the whole matrix must conform to the realization of the whole matrix. To state this another way, at any point in the realization, that which remains to be done must conform to what has already been done. A constant awareness of this will provide for specifying arbitrary entries as the realization develops.

To begin specification, note the state of the network at the conclusion of Phase 2. At this stage of the procedure, all type A circuits are to have been specified; therefore, it is logical to check the remaining circuits to make sure that there are no type A circuits that have not been accounted for because of the presence of arbitrary entries. At the conclusion of Phase 2 it is possible to determine sets of two or more type A circuits that traverse a common portion of the general linear subtree, and that do not have any common branches except those contained in the general linear subtree. Let λ_i and λ_j be two such circuits. In this case, if there is a circuit λ_k that is not contained in the set of type A circuits such that Z_{ik}^{OC} and Z_{jk}^{OC} are non-zero and such that the signs of Z_{ij}^{OC} , Z_{ik}^{OC} , Z_{jk}^{OC} , Z_{ii}^{OC} , Z_{jj}^{OC} , and Z_{kk}^{OC} can be made positive simultaneously, then the Z_{kr}^{OC} entries, where r is a type A circuit, must be adjusted so that λ_k is included as a type A circuit. The reasoning behind this is obvious. If three or more circuits $\{\lambda_e\}$ traverse a common set of branches, $\{b_e\}$,

and if the largest linear subtree common to two or more of those circuits is contained in $\{b_c\}$ and is also contained in the general linear subtree, then all circuits $\{\lambda_e\}$ must be type A circuits. In this manner the arbitrary entries can be specified.

When a Z^{OC} matrix is given with a large number of arbitrary entries, such entries can be designated as ± 0 . The realization procedure may be then more conveniently approached by realizing a portion of the Z^{OC} matrix that is a concentration of specified entries. Following that realization, the remaining circuits are added and arbitrary entries specified until the whole is realized.

3.4 Remarks

This realization method for Z^{OC} is different from that for Y^{SC} . Here no general sign matrix is presented. In Y^{SC} every entry has an associated sign, while in Z^{OC} only about half the zeros can be assigned a plus or minus. The remaining zeros have no sign associated with them.

The preceding realization procedure is presented as sufficient to warrant further investigation. Except in the large-scale general case, the procedure is not preferable to a "common sense" approach using the expansion-reduction technique. It is presented because in the general case its termination is more readily visible. However, for a common realization problem, a good understanding of the $\{\rho_a^3\}$ expansion-reduction concept is by itself the more effective approach, since it is also directly applicable to the realization of Y^{SC} matrices. In addition, most of the concepts and methods in this chapter appear directly applicable to the mesh impedance matrices, but are harder to prove.

IV. MULTIPORTS AND RELATED TOPICS

4.1 Relations between Y^{SC} , Z^{OC} , and Multiports

In the description of a network by an admittance or impedance matrix it is important to know exactly how the matrix was obtained. This is necessary because many characteristics of complete open-circuit and short-circuit matrices are very different from those of multiport matrices.

The preceding discussions on analysis and synthesis were concerned with complete short-circuit admittance matrices, Y^{SC} , and with complete open-circuit impedance matrices, Z^{OC} , both of n^{th} order. "Complete" indicates that the originating network is completely described by the responses of n independent branch voltages, or that the originating network is completely described by the responses of n independent branch currents. The terms "short-circuit" and "open-circuit" indicate which network variables are the responses and what form the equivalent excitations assume. "Short-circuit" refers to the fact that the response of the network is in terms of independent branch voltages and to the fact that all excitations may be replaced by current sources acting in those independent branches. "Open-circuit" refers to the fact that the response of the network is in terms of a set of independent branch currents and to the fact that all excitations may be replaced by voltage sources acting in those independent branches. It is very important to realize that in these matrices, Y^{SC} and Z^{OC} , the role of excitation and response cannot be reversed without changing the network graph. This can be seen by examining one independent branch in which the roles of excitation and response are reversed (see Figure 27 and Figure 28). These two figures show how a reversal of excitation and response roles in Y^{SC} and

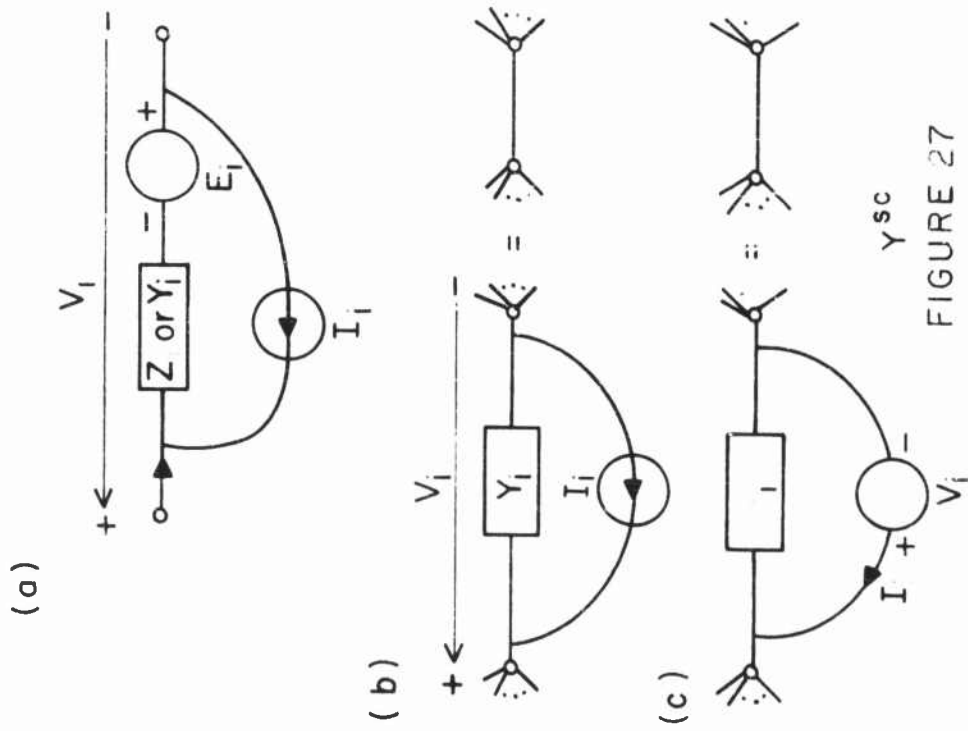

FIGURE 27

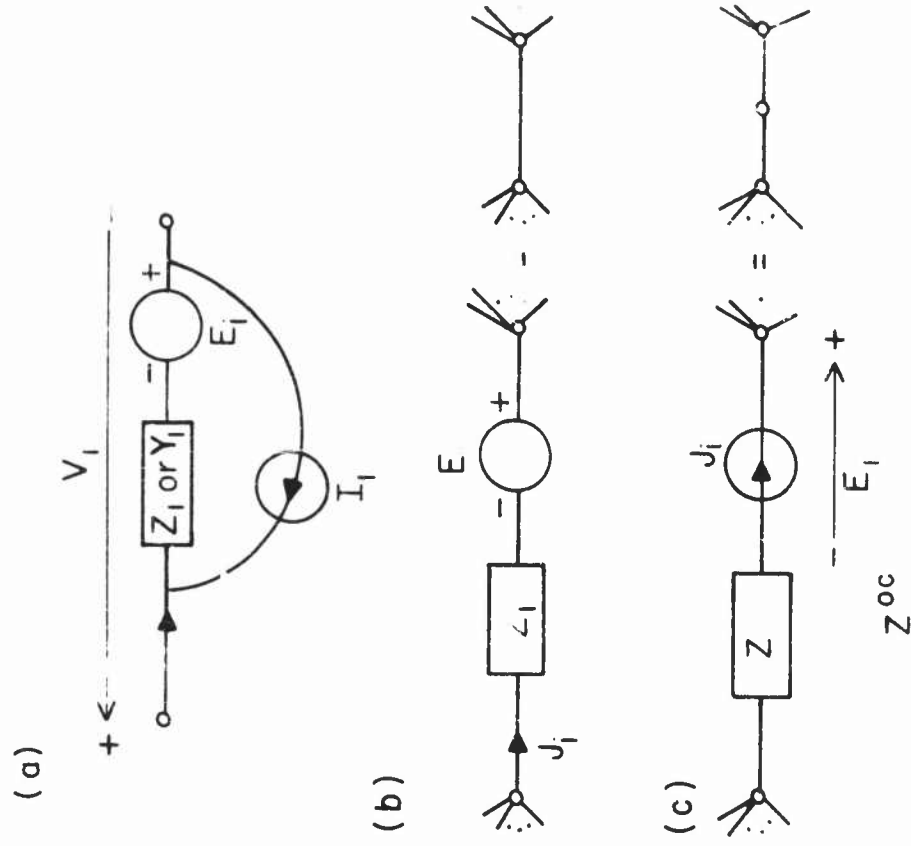

FIGURE 28

FIGURE 27, Figure 28.

Changes in Network Graph Accompanying Excitation and Response Changes: (a) Generalized Branch (b) Independent Branch and Corresponding Graph; (c) Branch with Excitation and Response Nodes Interchanged and Corresponding Graph.

Z^{OC} require that a new branch be added to contain the new source excitation. If this new branch were not added, the basic generalized branch definition would be violated, since a new voltage source would parallel an impedance, or a new current source would be in series with an admittance, thus violating the general branch shown in Figure 27a and 28a.

This change in network graph accompanying the reversal of excitation and response roles does not occur when the admittance or impedance matrix is viewed as an n-port matrix. This is because the port matrix essentially ignores the network topology and is concerned only with terminal behavior. It describes the network response only in so far as the terminal response is concerned and it demands that the excitation always occur at the specified terminals. If a graph is given for a network, and Z^{OC} and Y^{SC} are viewed as n-port impedance and admittance matrices, the role of excitation and response may be reversed with requiring any change in the network graph. As illustrated in Figure 29, this is because each excitation by itself is considered to be a separate network branch. Because of this, the previous statement concerned with Y^{SC} and Z^{OC} excitation and response reversal may be extended as follows

In Y^{SC} the response is in terms of a complete set of independent branch voltages and the excitation is in terms of equivalent current sources located within the same independent branches; in Z^{OC} the response is in terms of a complete set of independent branch currents, and the excitation is in terms of equivalent voltage sources. If at a particular independent branch the roles of excitation and response are reversed, then that reversal is accompanied by definite change in the network graph except in the isolated case where the network graph remains the same if and only if that independent branch admittance (impedance) is identically zero.

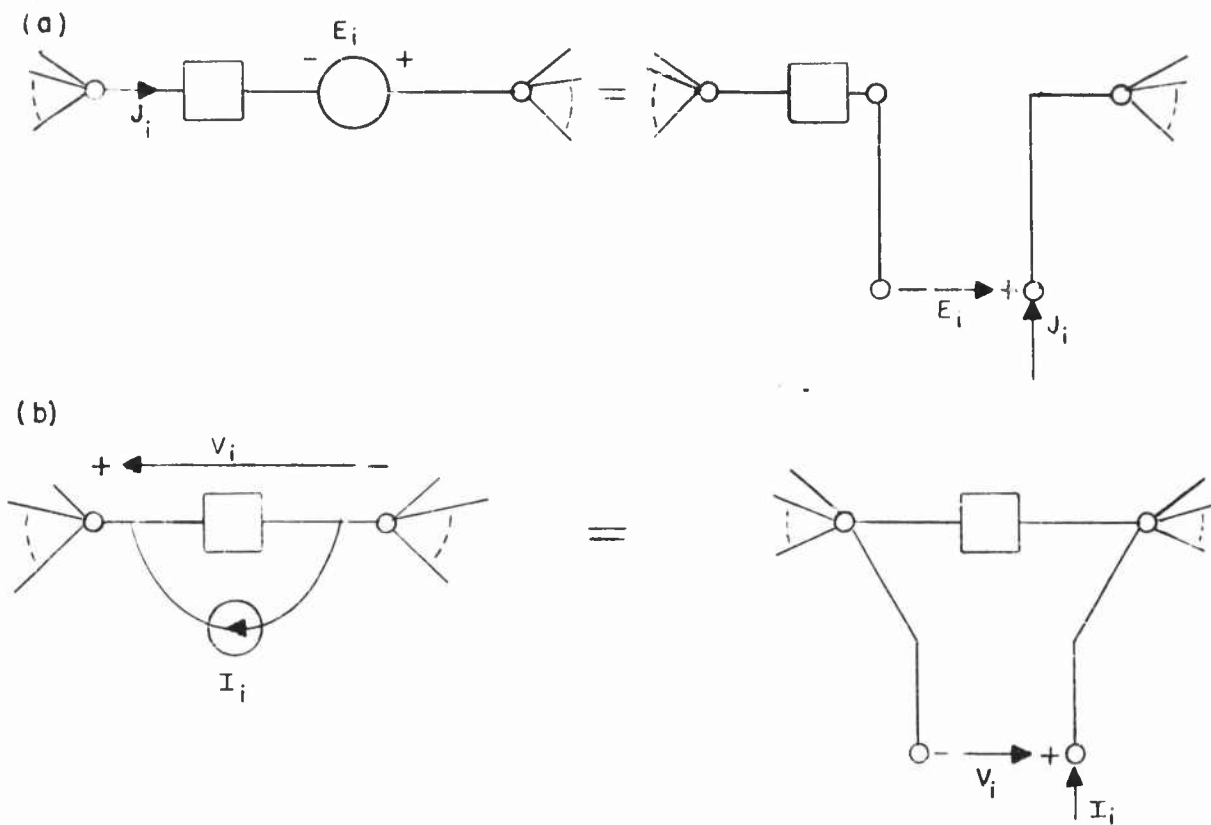

Figure 29. Change in Network Perspective When Z^{OC} or Y^{SC} Are Viewed as n-Port Matrices: (a) Z^{OC} Independent Branch Viewed as a Port, (b) Y^{SC} Independent Branch Viewed as a Port.

It should now be obvious that an n^{th} order complete short-circuit admittance matrix is automatically an n-port admittance matrix, that an n^{th} order complete open-circuit impedance matrix is automatically an n-port impedance matrix, and that the converse definitely does not hold.

If Z and Y represent n-port matrices, this may be expressed as

$$Y^{SC} \rightarrow Y \quad , \quad Z^{OC} \rightarrow Z \quad . \quad (48)$$

The necessary and sufficient conditions for the reverse to hold; that is,

$$Y \rightarrow Y^{sc} \quad , \quad Z \rightarrow Z^{oc} \quad , \quad (49)$$

is the existence of a network for which Equations (48) hold. One procedure for determining the existence of such a network is presented in Chapter II (admittance case) and Chapter III (impedance case). These two chapters bring out two strong dissimilarities between Y^{sc} and Y or Z^{oc} and Z . Most evident is the requirement that both the diagonal and the off-diagonal entries in Y^{sc} or Z^{oc} must involve sums of driving-point functions (therefore must be driving-point functions), and less evident are the dependence relations of the entry sign and zero entry.

In Y^{sc} and Z^{oc} equations, the independent variables (excitations) are given in terms of the dependent variables (responses); that is

$$E = Z^{oc} J \quad , \quad (50)$$

and

$$I = Y^{sc} V \quad , \quad (51)$$

where E and I refer to voltage and current sources, and J and V refer to current and voltage responses. Since the roles are interchangeable in port equations, it is the port equations that are desirable in network analysis because in them the dependent variables (responses) are expressible in terms of the independent variables (excitations). Port equations exist in varying degrees of completeness. The most complete admittance port equations are

$$J = [Z^{oc}]^{-1} E = Y^{sc} E \quad , \quad (52)$$

and the most complete impedance port equations are

$$V = [Y^{sc}]^{-1} I = Z^{oc} I \quad , \quad (53)$$

when these inverse matrices exist. Existence of the inverse matrices requires that $\det |Y^{SC}|$ and $\det |Z^{OC}|$ be non-zero; or, equivalently, that for $\det |Y^{SC}|$, there exists at least one network tree such that the product of its generalized branch admittance is greater than zero, and for $\det |Z^{OC}|$ there exists at least one network co-tree such that the product of its generalized branch impedances is greater than zero. The matrix $Y^{OC} (Z^{SC})$ is complete since the response of any branch current (voltage) to any set of source excitations is directly obtainable from simple algebraic combinations of the entries $Y_{ij}^{OC} (Z_{ij}^{SC})$. Their inverse matrices Y^{SC} and Z^{OC} , are, however, generally of little value as port equations that give responses of the network in terms of excitations, since by so doing they effectively destroy the network. This destruction should be clear upon considering Figures 30 and 31. In conjunction with this, let network N have b branches and n nodes, and be connected. Then if Y^{SC} is viewed as an $(n-1)$ -port matrix, the network has b independent branch currents; if viewed as a $(b-n+1)$ -port matrix, the network has b independent branch voltages.

4.2 Reduced Networks

The essential characteristic that excludes the consideration of most multiport matrices as Y^{SC} or Z^{OC} matrices is that many response variables within the network are not determinable. The equations $E = Z^{OC} J$ and $I = Y^{SC} V$ involve a complete independent set of n response currents and voltages respectively. Assume, however, that only the first k of these responses are of interest. It is then natural to eliminate the last $n-k$ variables as follows:

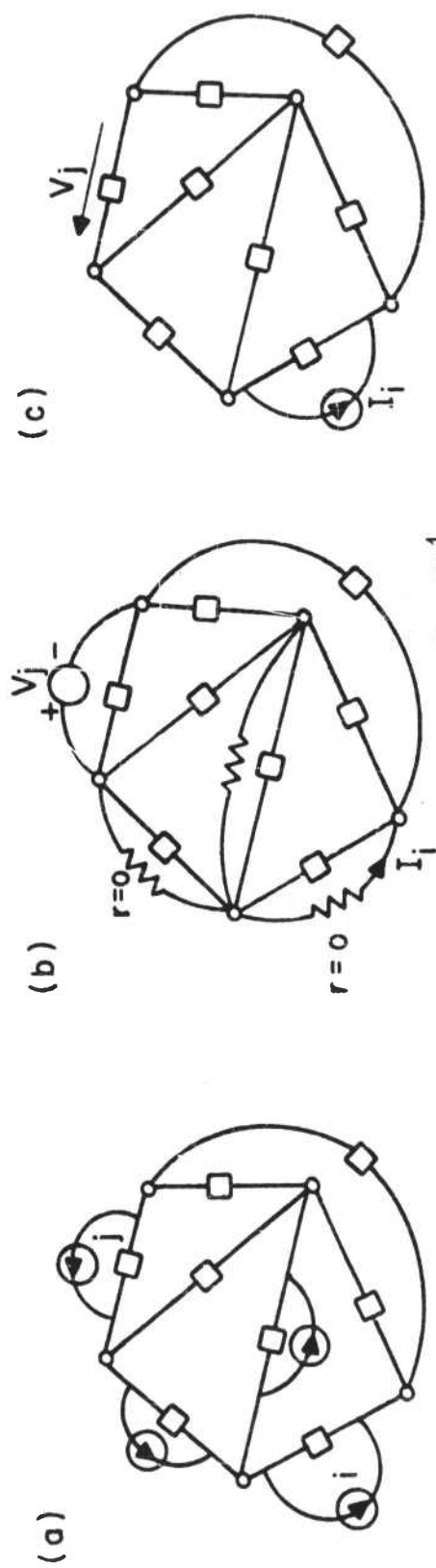

Figure 30. Interpretation of ij Entry in Y^{sc} and in $Z^{sc} = Y^{sc}{}^{-1}$: (a) Network Showing i and j Branches; (b) $Y_{ij}^{sc} = \frac{I_i}{V_j} = 0$; (c) $Z_{ij}^{sc} = \frac{V_j}{I_i} = 0$.

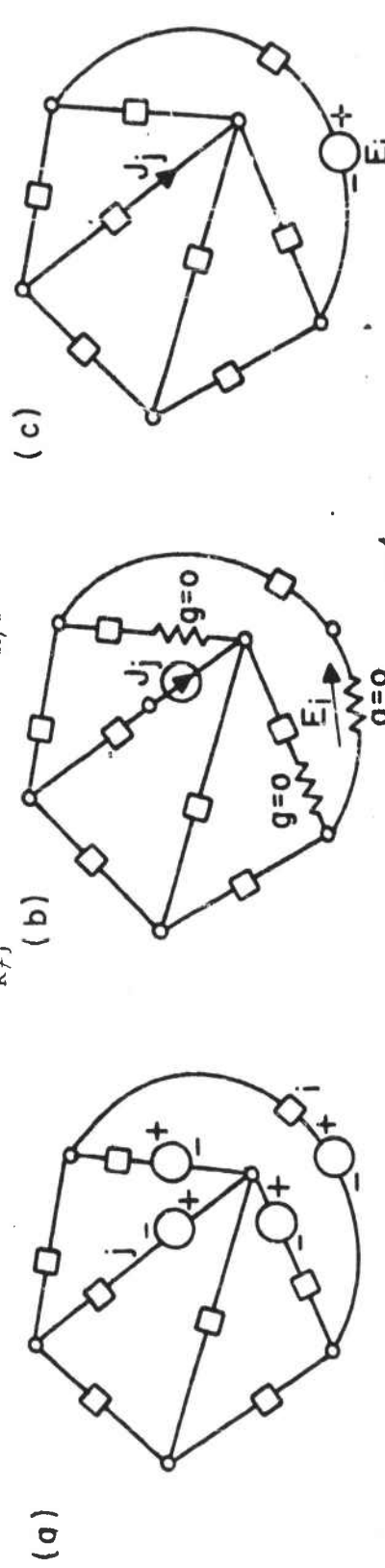

Figure 34. Interpretation of ij Entry in Z^{oc} and in $Y^{oc} = Z^{oc}{}^{-1}$: (a) Network Showing i and j Branches; (b) $Z_{ij}^{oc} = \frac{E_i}{I_j} = 0$; (c) $Y_{ij}^{oc} = \frac{I_j}{E_i} = 0$.

$$\begin{bmatrix} E_1 \\ \vdots \\ E_k \\ \hline E_{k+1} \\ \vdots \\ E_n \end{bmatrix} = \begin{bmatrix} Z_{k,k}^{oc} & Z_{k,n-k}^{oc} \\ \hline Z_{n-k,k}^{oc} & Z_{n-k,n-k}^{oc} \end{bmatrix} \begin{bmatrix} J_1 \\ \vdots \\ J_k \\ \hline J_{k+1} \\ \vdots \\ J_n \end{bmatrix} \quad (54)$$

or

$$E_{k,1} = Z_{k,k}^{oc} J_{k,1} + Z_{k,n-k}^{oc} J_{n-k,1}$$

$$Z_{k,n-k}^{oc} \left(Z_{n-k,n-k}^{oc} \right)^{-1} E_{n-k,1} = Z_{k,n-k}^{oc} \left(Z_{n-k,n-k}^{oc} \right)^{-1} Z_{n-k,k}^{oc} J_{k,1} + Z_{k,n-k}^{oc} J_{n-k,1}$$

(55)

where

$$\begin{bmatrix} E_{k,1} \\ \hline E_{n-k,1} \end{bmatrix} = \begin{bmatrix} E_1 \\ \vdots \\ E_k \\ \hline E_{k+1} \\ \vdots \\ E_n \end{bmatrix}$$

and

$$\begin{bmatrix} J_{k,1} \\ \dots \\ J_{n-k,1} \end{bmatrix} = \begin{bmatrix} J_1 \\ \dots \\ J_k \\ \dots \\ J_{k+1} \\ \dots \\ J_n \end{bmatrix}$$

Subtracting Equations (54) and (55) gives

$$E_{k,1} - Z_{k,n-k}^{oc} \left(Z_{n-k,n-k}^{oc} \right)^{-1} E_{n-k,1} = \left\{ Z_{kk}^{oc} - Z_{k,n-k}^{oc} \left(Z_{n-k,n-k}^{oc} \right)^{-1} Z_{n-k,k}^{oc} \right\} J_{k,1}$$

Rewriting this equation gives

$$E_{k,1} - E_{k,1}^n = E_{k,1}^o = \left\{ Z_{kk}^{oc} - Z_{k,n-k}^{oc} \left(Z_{n-k,n-k}^{oc} \right)^{-1} Z_{n-k,k}^{oc} \right\} J_{k,1} \quad (56)$$

where

$$E_{k,1}^n = Z_{k,n-k}^{oc} \left(Z_{n-k,n-k}^{oc} \right)^{-1} E_{n-k,1}$$

and

$$E_{k,1}^o = E_{k,1} - E_{k,1}^n$$

where $E_{k,1}^o$ represents the new equivalent voltage excitations acting in the first k independent branches. The interpretation of $E_{k,1}^o$ is significantly different from E . Recall that E represents all excitations in the network

replaced by an equivalent set of voltage excitations in the independent branches. However, $E_{k,1}^n$ is a set of voltage sources in the first k independent branches for the purpose of negating the effect of any sources in the "floating" portion of the network on the first k response currents. Therefore $E_{k,1}^o$ represents all excitations in the network replaced by an equivalent set of voltage excitations in the first k independent branches such that all excitations in the floating branches are effectively zero. As a natural consequence of this we assume $E_{n-k,1} = 0$, so that, for simplicity, we may write

$$E_{k,1}^o = E_{k1} = \left\{ Z_{kk}^{oc} - Z_{k,n-k}^{oc} \left(Z_{n-k,n-k}^{oc} \right)^{-1} Z_{n-k,k}^{oc} \right\} J_{k,1} \quad (57)$$

Similarly, for Y^{sc} ,

$$\begin{aligned} I_{k,1} - Y_{k,n-k}^{sc} \left(Y_{n-k,n-k}^{sc} \right)^{-1} I_{n-k,1} \\ = I_{k,1} - I_{k,1}^n = I_{k,1}^o = I_{k,1} = \left\{ Y_{kk}^{sc} - Y_{k,n-k}^{sc} \left(Y_{n-k,n-k}^{sc} \right)^{-1} Y_{n-k,k}^{sc} \right\} V_{k,1} \end{aligned} \quad (58)$$

In conjunction with Equations (54) and (58), note that if

$$\left[Z^{oc} \right]^{-1} = \left[\begin{array}{c|c} Z_{kk}^{oc} & Z_{k,n-k}^{oc} \\ \hline Z_{n-k,k}^{oc} & Z_{n-k,n-k}^{oc} \end{array} \right]^{-1} = \left[\begin{array}{c|c} Y_{k,k}^{oc} & Y_{k,n-k}^{oc} \\ \hline Y_{n-k,k}^{oc} & Y_{n-k,n-k}^{oc} \end{array} \right] = Y^{oc} \quad (59)$$

then

$$Y_{kk}^{oc} = \left\{ Z_{kk}^{oc} - Z_{k,n-k}^{oc} \left(Z_{n-k,n-k}^{oc} \right)^{-1} Z_{n-k,k}^{oc} \right\}^{-1} \quad (60)$$

This process of allowing certain independent branches to float leads to two types of matrices. If the remaining independent branches form a single subtree of the original maximal tree, then the resulting matrix will be called a complete multiport matrix. It is complete, because if the resulting matrix has k ports, then these ports form a tree and therefore require only $k + 1$ terminals. However, if the remaining independent branches form several unconnected subtrees of the original maximal tree, then the resulting matrix will be called an incomplete multiport matrix, or simply a multiport matrix.

The inclusion of multiterminal elements, which are mathematically described by a complete multiport matrix, in the discussion on admittance and impedance is a natural consequence of reducing the number of response voltages and currents described. The discussion following will describe network analysis of networks with multiterminal elements. This discussion assumes that sources are present only in the independent branches that are not floating. This assumption, as shown above, does not affect operations on the Z or Y matrices; it only simplifies the interpretation of the excitation source vector, and as such does not affect the results.

4.3 Network Analysis Involving Multiports

Let N be a network containing b branches and n nodes. Let the n nodes be grouped into three mutually exclusive sets n_1 , n_2 , and n_3 . Assume that no branch exists that is incident on both an n_1 node and an n_3 node (see Figure 32). Call a branch that is incident on an n_i node and an n_j node b_{ij} . Then there exist five types of branches in N : b_{11} , b_{22} , b_{33} , b_{12} , and b_{23} . In general, a maximal tree of N will contain all five

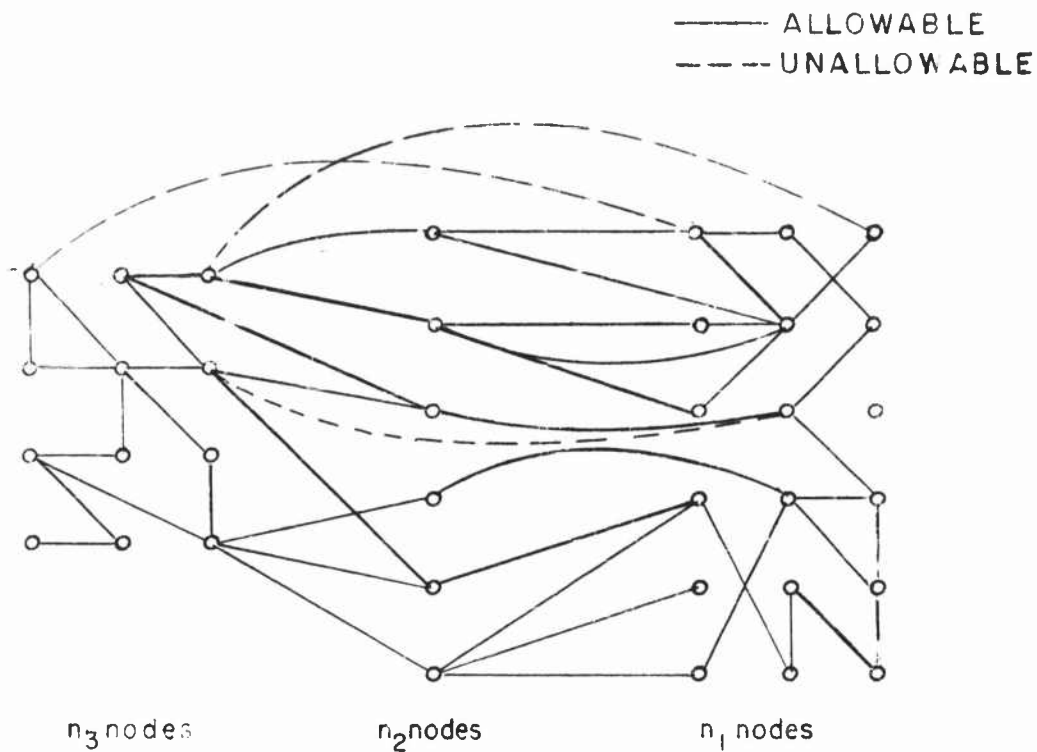

Figure 32. Example of Allowable and Unallowable Branches.

types of branches. Let a maximal tree be selected such that all b_{22} tree branches form a single subtree, such that all b_{22} , b_{11} and b_{12} tree branches taken together form a single subtree, and such that all b_{22} , b_{33} , and b_{23} tree branches taken together form a single subtree. Based on this maximal tree, the set of independent branch voltages, $\{V\}$, may be ordered such that

$$\{V\} = \{V_1, V_2, \dots, V_j, V_{j+1}, \dots, V_k, V_{k+1}, \dots, V_{n-1}\} \quad (61)$$

where

$\{V_1, \dots, V_j\}$ are response voltages across the b_{11} and b_{12} branches,

$\{V_{j+1}, \dots, V_k\}$ are response voltages across the b_{22} branches, and

$\{V_{k+1}, \dots, V_{n-1}\}$ are the response voltages across the b_{23} and b_{33} branches.

Since no b_{13} branches exist, and therefore no corresponding independent branch voltages from an n_1 node to an n_3 node, the complete short-circuit admittance matrix takes the form of matrix (62):

$$Y^{sc} = \begin{array}{c} 1 \\ \vdots \\ j \\ \hline j+1 \\ \vdots \\ k \\ \hline k+1 \\ \vdots \\ n-1 \end{array} \left[\begin{array}{c|c|c} & & \\ \hline & P_1 & A & 0 \\ \hline & A_t & C & B \\ \hline & 0 & B_t & P_3 \end{array} \right] \quad (62)$$

If the variables V_{k+1}, \dots, V_{n-1} are allowed to "float" and are thus removed from the admittance equations, the matrix Y^{sc} becomes a complete multiport admittance matrix Y , which is,

$$Y = \begin{bmatrix} P_1 & | & A \\ \hline A_t & | & C - BP_3^{-1} B_t \end{bmatrix} \quad (63)$$

In matrix (62) and matrix (63), P_1 is concerned solely with b_{11} and b_{12} branches; A is concerned solely with b_{12} branches, P_3 is concerned solely with b_{33} and b_{23} branches; B is concerned solely with b_{23} branches; and C is concerned with b_{11} , b_{12} , b_{22} , b_{23} , and b_{33} branches. Let C be written as a sum $C = C_1 + C_2$, where C_1 is concerned solely with b_{11} , b_{12} , and b_{22} branches, and C_2 is concerned solely with b_{33} , b_{23} , and b_{22} branches. Then, matrix (63) can be written as

$$Y = \begin{bmatrix} P_1 & A \\ A_t & C - BP_3^{-1} B_t \end{bmatrix} = \begin{bmatrix} P_1 & A \\ A_t & C_1 \end{bmatrix} + \begin{bmatrix} 0 & 0 \\ 0 & C_2 - BP_3^{-1} B_t \end{bmatrix} \quad (64)$$

$$= Y_1 + Y_3,$$

where

$$Y_1 = \begin{bmatrix} P_1 & A \\ A_t & C_1 \end{bmatrix},$$

$$Y_3 = \begin{bmatrix} 0 & 0 \\ 0 & C_2 - BP_3^{-1} B_t \end{bmatrix} \quad (65)$$

Now let N be represented as a union of two networks $N_1 \cup N_3$, where N_1 and N_3 have no common non-zero branches and have the set of n_2 for

common nodes. The specific branches in N_1 are the b_{11} , b_{12} , and b_{22} branches that appear in C_1 ; the specific branches in N_3 are the b_{33} , b_{23} , and b_{22} branches that appear in C_3 . Parallel branches in b_{22} must be allowed.

With respect to Y_1 , note that if all the branches in N_2 are removed from N (that is, all branch admittances in N_2 are set equal to zero) then matrix (62) becomes

$$Y^{sc} = \left[\begin{array}{cc|c} P_1 & A & 0 \\ A_t & C_1 & 0 \\ \hline 0 & 0 & 0 \end{array} \right] = \left[\begin{array}{c|c} Y_1 & 0 \\ \hline 0 & 0 \end{array} \right] \quad (66)$$

Therefore Y_1 is actually the complete short-circuit admittance matrix of N_1 ; that is,

$$Y_1 = Y_{N_1}^{sc} \quad (67)$$

With respect to Y_3 , note that if all the branches in N_1 are removed from N , then matrix (62) becomes

$$Y^{sc} = \left[\begin{array}{ccc} 0 & 0 & 0 \\ 0 & C_2 & B \\ 0 & B_t & P_3 \end{array} \right],$$

and if the variables V_{k+1}, \dots, V_{n-1} are allowed to float, then matrix (63) becomes

$$\begin{aligned}
 Y &= \begin{bmatrix} 0 & 0 \\ 0 & C_2 - BP_3^{-1} B_t \end{bmatrix} = Y_3, \\
 &= \begin{bmatrix} 0 & 0 \\ 0 & Y_{N_3}^{CMP} \end{bmatrix}
 \end{aligned} \tag{68}$$

where $Y_{N_3}^{CMP} = C_2 - BP_3^{-1} B_t$ is the complete multiport admittance matrix for network N_3 where all the b_{23} and b_{33} independent branch voltages are floating. Thus matrix (64) becomes

$$Y = Y_{N_1}^{sc} + Y_3 = Y_{N_1}^{sc} + \begin{bmatrix} 0 & 0 \\ 0 & Y_{N_3}^{CMP} \end{bmatrix} \tag{69}$$

Equation (69) is merely the multiport admittance matrix for a network N_1 into which a multiport network N_3 has been inserted. The important restrictions here are that the admittance matrix for the multiport N_3 be complete, and that the corresponding ports of N_1 into which it is plugged form a single subtree of the maximal tree of N_1 .

The impedance development follows the same text as the admittance development with the natural substitution of dual quantities. After this substitution, the following dual equation results:

$$Z = Z_{N_1}^{oc} + Z_3 = Z_{N_1}^{oc} + \begin{bmatrix} 0 & 0 \\ 0 & Z_{N_3}^{CMP} \end{bmatrix} \tag{70}$$

With reference to Equations (64) and (69), the only portion of $Y_{N_1}^{sc}$ that is affected is C_1 . A careful analysis of this shows that only the entry magnitudes are affected; that is, the signs of C_1 are identical to the signs of $C_1 + C_2 - BP_3^{-1} B_t$. In addition, one should observe that the common problem of circulating currents is nonexistent in this type of connection; that is, any "circulating currents," if they exist, are automatically taken care of throughout the process described in Section 4.3.

APPENDIX A: EXPLANATION OF TERMS

Primary Axiom: If M is an arbitrary finite or infinite collection of elements, and if to each (unordered) pair (A, B) of elements in M , a finite or infinite integer $M_{AB} = M_{BA} \geq 0$ is assigned such that for each A at least one M_{AB} is non-zero. Call this a graph, which designates the elements of M as nodes and in which any two nodes A and B are joined by M_{AB} branches. This axiom is used in this study only for the case where M and M_{AB} are finite.

Subgraph: If the nodes of graph G_1 are at the same time nodes of graph G and if the branches of graph G_1 are likewise the branches of G , then G_1 is a "subgraph" of G .

Incidence: If a branch AB terminates on a node A , then that node and branch are "incident" to one another.

Degree: The number of branches that are incident on a node P of a graph G is the "degree" of P in G .

Branch Sequence: If one can enumerate all the branches of a (finite) graph in a sequence of the form,

$$AB, BC, CD, \dots, KL, LM, \dots, \quad (74)$$

where each node and each branch can occur arbitrarily (finitely) often, the graph is called a "branch sequence." When $A \neq M$ call the branch

sequence "open;" when $A = M$, call it "closed." If a branch occurs in Equation (71) n -times, then call n the "multiplicative index" or "multiplicity" of the branch with reference to the branch sequence.

Branch Train: If no branch occurs twice in Equation (71), then call the branch sequence a "branch train" (open or closed). If, in addition, the points, A, B, \dots, L, M , are collectively different from one another, then call the open branch train a "path;" if $A = M$, but A, B, \dots, L collectively differ from one another, call the closed branch train a "circuit."

Connected Graph: If a path exists between each pair (A, B) of nodes in a graph G , then call G a "connected graph."

Tree: If G_1 is a connected subgraph of G , such that all the nodes of G are contained in G_1 and such that no circuits in G_1 exist, then call G_1 a "tree" with respect to G .

Co-Tree: If G_1 is a tree with respect to G , then call all the branches of G not contained in G_1 the complement of G_1 , or "co-tree."

Chord: Call a branch of a co-tree a "chord."

APPENDIX B: MAXIMUM NUMBER OF BRANCHES IN PLANAR GRAPH

Through a straightforward application of Euler's formula which relates the number of faces, edges, and vertices for a simple polyhedron one may surmise that the maximum number of branches in an n -node planar graph is $3n - 6$. Since there is some question as to whether this constitutes a valid proof, the following proof, which relies on Kuratowski's two basic nonplanar graphs, is offered. Three assumptions are made:

- i) A graph is composed of branches and nodes.
- ii) A branch always terminates on a node at both ends and does not terminate on the same node at both ends.
- iii) Given any two nodes, there exists at most one branch terminating on those two nodes.

Theorem: If a graph G contains n nodes and b branches and is said to be planar, then for $n \geq 3$, $b \leq 3n - 6$.

Proof. The maximum number of unique branches in any three node graph $n = 3$ is $\frac{n^2 - n}{2} = 3 = 3n - 6$ and any combination of those branches is trivially planar (see Figure 33a).

The maximum number of unique branches in any four node graph $n = 4$, is $\frac{n^2 - n}{2} = 6 = 3n - 6$, and any combination of those branches is trivially planar (see Figure 33b).

Assume a planar graph has $b = 3n - 6 + a$ for $n \geq 5$, $a > 0$. Since a graph is planar if and only if every subgraph is planar, it will suffice to erase any $a - 1$ branch and show that the remaining graph G' having n nodes and $3n - 5$ branches is nonplanar. For G' there exists

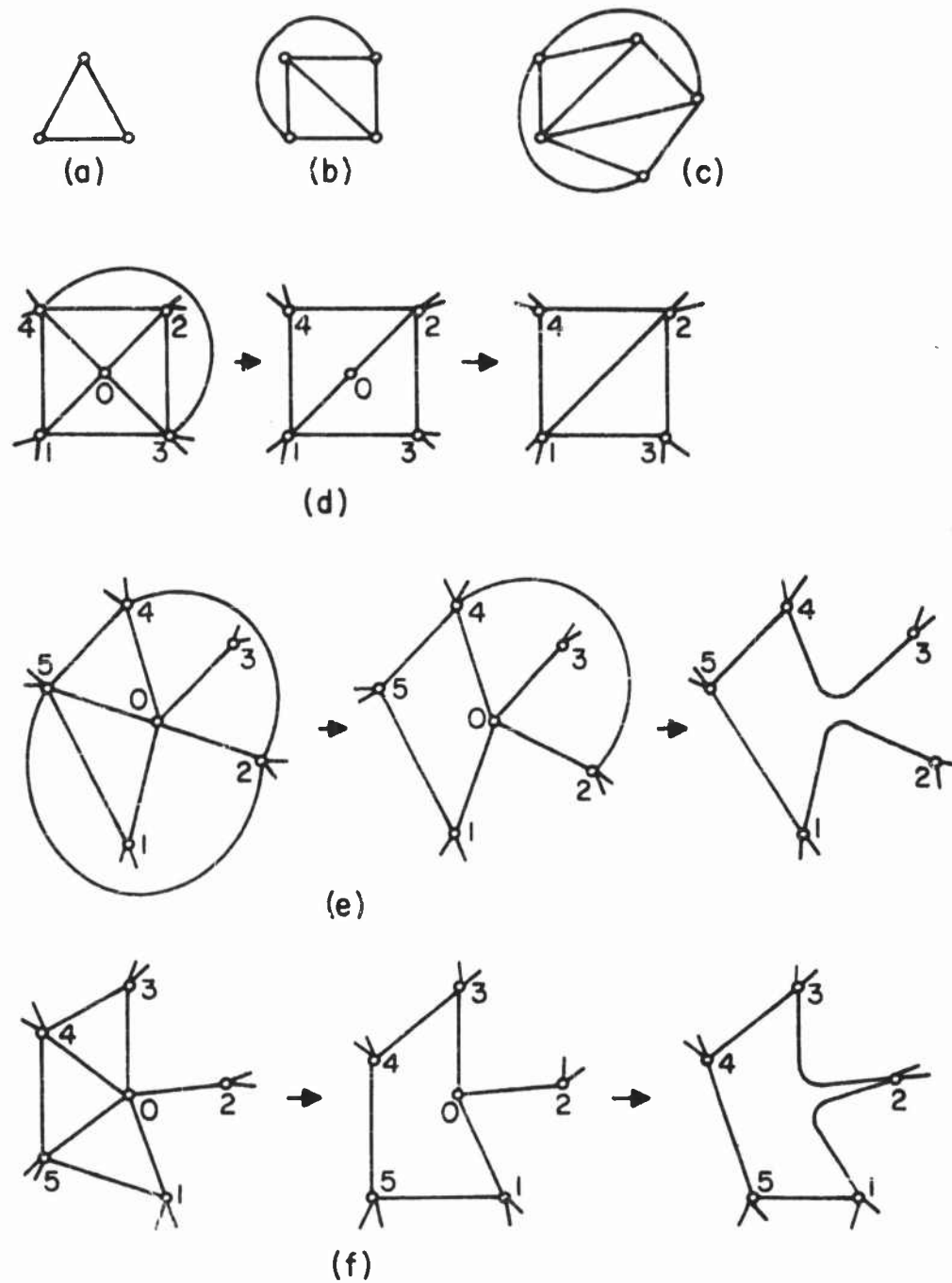

Figure 33 Examples of Geometrical Construction Used in Proof.

at least one node, n_0 , with five or fewer branches terminating on it. If not, there would be at least $6n/2 = 3n$ branches in G' contrary to construction.

Case 1: If n_0 has zero branches terminating on it, erase n_0 and three arbitrary branches in G' .

Case 2: If n_0 has one branch b_{01} terminating on it, erase n_0 and b_{01} and two other arbitrary branches in G' .

Case 3: If n_0 has two branches b_{01} and b_{02} terminating on it, erase n_0 , b_{01} , b_{02} , and one other arbitrary branch in G' .

Case 4: If n_0 has three branches b_{01} , b_{02} , and b_{03} terminating on it, erase n_0 , b_{01} , b_{02} , b_{03} .

Case 5: If n_0 has four branches b_{01} , b_{02} , b_{03} , b_{04} terminating on n_0 at one end and on n_1 , n_2 , n_3 , and n_4 at the other end respectively then there exists a pair of nodes n_i and n_j (where $i, j = 1, 2, 3, 4$; $i \neq j$), such that there is no branch b_{ij} connecting that pair of nodes in G' . If this were not the case, each of the five nodes would be connected to each of the other four nodes and thus the subgraph composed of the five nodes and their connecting branches would constitute Kuratowski's first basic nonplanar form thus requiring G' to be nonplanar. Erase n_0 , b_{01} , b_{02} , b_{03} , b_{04} , and add branch b_{ij} such that the planar characteristic is not altered. This is possible as follows: Let $i = 1$, $j = 2$. Erase b_{03} and b_{04} . Now replace the chain b_{01} , n_0 , b_{02} by the branch b_{12} thus not altering the planar characteristic of G' (see Figure 33d).

Case 6: If n_0 has five branches b_{01} , b_{02} , ..., b_{05} terminating on n_0 at one end and on n_1 , n_2 , ..., n_5 at the other end respectively, then there exist three different pairs of nodes n_i and n_j , n_k and n_l .

and n_m and n_n (where $i, j, k, m, n = 1, 2, \dots, 5$, when $i \neq j$, $k \neq j$, $m \neq n$, and either $m = i$ with $n \neq k$, or $m = j$ with $n \neq i, k$), such that there are no branches b_{ij} , b_{kj} , and b_{mn} connecting those pairs of nodes in G' . If this were not the case, then the six nodes n_0, n_1, \dots, n_5 could be grouped into two sets of three each with the property that there would exist a branch from each node in one set to each node in the other set and vice versa. This comprises a definition of Kuratowski's second basic nonplanar graph, thus requiring G' to be nonplanar. Erase node n_0 , branches $b_{01}, b_{02}, \dots, b_{05}$, and add two of the branches b_{ij}, b_{kj} , and b_{mn} such that the planar characteristic of G' is not altered. This is possible in a manner similar to the method indicated in Case 5. Let $i = 1, j = 2, k = 3$. If $m = 3, n = 4$, erase branch b_{05} and replace the chain b_{01}, n_0, b_{02} by branch b_{12} , and the chain b_{04}, n_0, b_{03} by the branch b_{43} (see Figure 1e). If $m = 2, n = 4$, erase branches b_{05} and b_{04} and replace the chain b_{01}, n_0, b_{02} by the branch b_{12} , and the chain b_{03}, n_0, b_{02} by the branch b_{23} (see Figure 33f).

In all the preceding cases let the resultant subgraph of G' be G'' . Then G'' has $n - 1$ nodes and $3n - 5 - 3 = 3(n - 1) - 5$ branches. Let $n - 1 = n'$. Then G'' has n' nodes and $3n' - 5$ branches. Continue this process until $n = 5$ and let this remaining subgraph of G' be called G^5 . Now G^5 has five nodes and $15 - 5 = 10$ branches. A graph with five nodes and ten branches must have each node connected to every other node and hence is Kuratowski's first basic nonplanar graph. Since G^5 is nonplanar, G must be nonplanar, resulting in a contradiction.

The equality in the theorem follows from the following construction. Place three nodes on a sphere. Add the three unique branches to the graph.

Add a node. It must fall within a "triangle" and thus there are three branches that may be added in a planar manner. Add these three branches. Add another node, ..., etc. to construct a planar graph containing n nodes and $b = 3n - 6$ branches.

Corollary: If a planar graph with $n \geq 3$ nodes and $3n - 6$ branches is mapped on a sphere, the only existing loop with no branches appearing within it (or without it, as the case may be) is a loop containing three nodes and the three unique branches connecting them.

Proof: If there were four or more nodes in the loop, it would be possible to add one branch in a planar manner thus bringing the total number of branches to $3n - 5$, resulting in a contradiction.

BIBLIOGRAPHY

1. S. Seshu and M. B. Reed, Linear Graphs and Electrical Networks, Reading, Mass.: Addison Wesley, 1961.
2. G. Biorci and P. P. Civalleri, "On the Synthesis of Resistive N-Port Networks," I.R.E. Trans., CT-8 (March 1961), pp. 22-28.
3. E. A. Guillemin, "On the Analysis and Synthesis of Single-Element-Kind Network," MIT QPR No. 56 (January 1960), pp. 223-235.