

UNCLASSIFIED

AD 276 881

*Reproduced
by the*

**ARMED SERVICES TECHNICAL INFORMATION AGENCY
ARLINGTON HALL STATION
ARLINGTON 12, VIRGINIA**



UNCLASSIFIED

NOTICE: When government or other drawings, specifications or other data are used for any purpose other than in connection with a definitely related government procurement operation, the U. S. Government thereby incurs no responsibility, nor any obligation whatsoever; and the fact that the Government may have formulated, furnished, or in any way supplied the said drawings, specifications, or other data is not to be regarded by implication or otherwise as in any manner licensing the holder or any other person or corporation, or conveying any rights or permission to manufacture, use or sell any patented invention that may in any way be related thereto.

27 6881

MASSACHUSETTS INSTITUTE OF TECHNOLOGY
LINCOLN LABORATORY

BY ASTIA
AS AD NO.

22 G - 4

ON OPTIMAL LINEAR CONTROL SYSTEMS WHICH MINIMIZE THE
TIME INTEGRAL OF THE ABSOLUTE VALUE OF THE CONTROL
FUNCTION (MINIMUM-FUEL CONTROL SYSTEMS)

Michael Athanassiades

276 881

10 May 1962

The work reported in this document was performed at Lincoln Laboratory, a center for research operated by Massachusetts Institute of Technology, with the joint support of the U.S. Army, Navy and Air Force under Air Force Contract AF 33(694)-7100.

MASSACHUSETTS

ABSTRACT

If in a control system the plant is described by $\dot{y} = Ay + Bu$, $|u_j| \leq 1$, and if

during a control action it is desired to minimize the functional $F = \int_0^t \sum_{j=1}^r |u_j(\tau)| d\tau$,

then it is shown that each control signal $u_j(t)$ must be piecewise constant, with the values +1, 0, or -1, and that each control signal is a nonlinear function of the adjoint system. If each control signal is proportional to rate-of-flow of fuel (or mass), the results obtained lead to a "minimum-fuel" control system. Plants with single control inputs are also analyzed.

The theory is applied to the analysis and design of the minimum-fuel controller for two specific second-order plants. The first plant has the transfer function $1/s^2$ and the second $1/(s+1)(s+2)$. The optimum feedback control function is obtained as a function of the plant state variables.

JUN 27 1962
N-62-3-6
NSA

INTRODUCTION

In the past five years the theory of control systems has been influenced by a host of elegant mathematical techniques, mostly based on the Calculus of Variations. Perhaps the most celebrated theoretical result is the "Maximum Principle" originated by Pontriagin and his colleagues, which is related to the theory of Dynamic Programming.

The best known optimum control system is the minimum time one, or as it is commonly called, the "bang-bang" control system. During the last year, however, the attention has shifted to other optimal control systems, such as the minimum energy one.

In this report we examine the so-called "minimum-fuel" optimum control system. We are concerned with systems for which the control signal is proportional to fuel, such as fuel exhaust in a missile or gas exhaust from a gas jet in an attitude control system. The total fuel consumed during a control action is proportional to the time integral of the absolute value of each control signal. If we are given a linear system which is to execute a given task, then we are interested in determining the control signal which requires the least amount of fuel to accomplish the given task. We also assume that each control signal is bounded in magnitude by unity.

In Section 1 of this report we define the problem mathematically, and we state the theoretical results which will be employed. In (1.5) we derive the optimal control law for minimum fuel operation which states that each control signal is piecewise constant and is ± 1 , 0 , or -1 , if unity is the bound on each control, and that the magnitude and polarity of each control signal is a nonlinear function of the output of the adjoint system.

In the second Section we examine the minimum fuel control of a plant described by an n^{th} - order linear differential equation with constant coefficients. We use the similarity transformation in order to define a convenient set of state variables.

In the third Section we use the theory to design a minimum fuel controller for a double integral plant. The system is analyzed using the trajectories in the phase plane and utilizing the information obtained from the adjoint system. The controller is shown in Fig. 8.

In the fourth Section we examine in great detail the optimum minimum fuel control of a second-order plant with two real, negative, and distinct poles. Through the use of phase-plane trajectories, and using the concept of equal fuel lines, we arrive at a separation of the phase plane into three regions of operation. For each region of operation there exists an optimal value of the control signal.

This study is not exhaustive. A general method for computing the optimal control for minimum fuel operation of any system is not given. However, the examples presented may be used to determine the optimal control of similar types of systems.

1. MATHEMATICAL THEORY

1.1 Introduction .

In this Section the problem of minimum-fuel control is stated in precise terms. The terminology is established. The available theory of optimal control systems is briefly reviewed and is used in order to derive the optimal control law for minimum fuel systems.

1.2 Statement of the Problem

We are given a dynamical system described by the matrix differential equation

$$\dot{\underline{y}} = \underline{A}\underline{y} + \underline{B}\underline{u}(t). \quad 1-1$$

We shall refer to the system described by Eq. 1-1 as the (controlled) plant. The plant is assumed to be linear, time-invariant, and stable.

In Eq. 1-1:

$\underline{y} = \{y_1, y_2, \dots, y_n\}$ is an n -column vector called the state of the plant.

$\underline{A} = (a_{ij})$ is an $n \times n$ real constant matrix.

$\underline{u}(t) = \{u_1, u_2, \dots, u_r\}$ is an r -column vector called the control.

$\underline{B} = (b_{ij})$ is an $r \times n$ real constant matrix.

n is the order of the plant in Eq. 1-1.

We assume that each element of the control vector $\underline{u}(t)$ is bounded in magnitude by unity, i. e.,

$$|u_j(t)| \leq 1 \quad ; \quad j = 1, 2, \dots, r \quad 1-2$$

The assumption that unity is the bound of each element of the control function is for the

sake of simplicity and it is immaterial to the theory which will follow.

We want to determine an admissible control $\underline{u}^0(t)$, i. e., a control vector which satisfies the restrictions imposed by Eq. 1-2, which will force the plant from an initial state \underline{y}_0 to a final state \underline{y}_f such that the functional

$$F = \int_0^{t_f} \left\{ \sum_{j=1}^r |u_j(t)| \right\} dt \quad 1-3$$

is minimum. We will call the time t_f the response time.^φ

Succinctly, the statement of the problem is as follows: Determine the control $\underline{u}^0(t)$ such that

$$\int_0^{t_f} \left\{ \sum_{j=1}^r |u_j^0(t)| \right\} dt < \int_0^{t'_f} \left\{ \sum_{j=1}^r |u_j(t)| \right\} dt \quad 1-4$$

for all $\underline{u}(t) \neq \underline{u}^0(t)$, with the constraints

$$\left. \begin{aligned} \dot{\underline{y}} &= \underline{A}\underline{y} + \underline{B}\underline{u}(t) \\ \underline{y}(0) &= \underline{y}_0 \quad ; \quad \underline{y}(t_f) = \underline{y}(t'_f) = \underline{y}_f \quad \text{fixed} \\ |u_j(t)| &\leq 1 \quad ; \quad j = 1, 2, \dots, r \end{aligned} \right\} \quad 1-5$$

where the response times t_f and t'_f are not fixed.

^φ The more general functional $\int_0^{t_f} \left\{ \sum_{j=1}^r |c_j u_j(t)| \right\} dt$, where c_j are some constants

can also be handled by the theory with some trivial changes.

1.3 Discussion of the Problem .

There are many physical systems which can be mathematically represented in the form of Eq. 1-1. Time-varying and nonlinear systems are excluded. It is also assumed that the systems are noise-free.

The control signals $u_j(t)$ act as the inputs to the controlled plants. There are many cases for which each control signal represents the reaction provided by the exhaust of mass as discussed in the Introduction. Then the absolute value of each control signal physically represents rate-of-flow of mass or fuel. Hence, the functional in Eq. 1-3 represents the total fuel consumption necessary for the control of the plant. Minimization of the fuel F_j by the appropriate choice of the controls $u_j(t)$, leads to a minimum-fuel control system. Throughout this report optimal control system will mean minimum-fuel control system.

The assumption on the bound of the control signals, as provided by Eq. 1-2, is due to the saturation phenomena of power-amplifying elements in electrical systems, or due to other physical considerations. For example, in an attitude control system there exists a maximum torque which the escaping gas can provide due to design considerations.

The plants examined are assumed to be controllable. For a precise mathematical definition of controllability the reader is referred to Refs. 1 and 2. Loosely speaking, controllability implies that the objectives of the control system, i. e., the transfer of the state from y_0 to y_f , must be consistent with its capabilities, which are determined from the nature of the matrix \underline{A} and the bound imposed on the control functions.

If the system is controllable, then there are, usually, many admissible controls which will force the plant from an initial state to a desired final state. Each of the controls will result in a certain amount of consumed fuel. The optimization procedure will lead to the determination of the control(s) which will require the least amount of fuel.

1.4 Theory of Optimal Control

In this Section we will state briefly the latest results in the mathematical theory of control. For details the reader is referred to Refs. 3, 4, 5, and 6. The terminology of Ref. 3 is used in this section.

We are given a system described by the differential equation

$$\dot{\underline{y}} = \underline{f}(\underline{y}, \underline{u}(t), t) \quad 1-6$$

where \underline{y} is the state vector and \underline{u} is the control vector. Let \underline{y}_0 denote the initial state at $t = t_0$. Let the solution of Eq. 1-6 be

$$\underline{\phi}(t) = \underline{\phi}_{\underline{u}}(t ; \underline{y}_0, t_0). \quad 1-7$$

Assume that the control $\underline{u}(t)$ is an element of a closed convex set Ω , i.e., $\underline{u}(t) \in \Omega$.

Let S be a surface in the state space. We are given the scalar functional

$$V(\underline{y}_0, t_0, S ; \underline{u}) = \int_{t_0}^{t_1} L(\underline{\phi}, \underline{u}, t) dt \quad 1-8$$

where t_1 is the time for which $\underline{\phi}(t) \in S$ for the first time.

It is desired to find the optimal control $\underline{u}^0(t), \underline{u}^0(t) \in \Omega$, such that the functional of Eq. 1-8 is minimum with respect to all other admissible controls.

The following steps must be followed in order to determine a set of necessary, but not sufficient, conditions on the optimal control $u^0(t)$.

Step 1: Form a scalar function H , called the Hamiltonian,

$$H(\underline{y}, \underline{p}, \underline{u}, t) = L(\underline{y}, \underline{u}, t) + \langle \dot{\underline{y}}, \underline{p} \rangle, \quad 1-9$$

where \underline{p} is a vector called the costate, and $\langle \dot{\underline{y}}, \underline{p} \rangle$ is the scalar product of the vectors $\dot{\underline{y}}$ and \underline{p} .

Step 2: Find the absolute minimum of the Hamiltonian H with respect to all admissible controls. Let

$$H^*(\underline{y}, \underline{p}, t) = \min_{\underline{u} \in \Omega} H(\underline{y}, \underline{p}, \underline{u}, t) \quad 1-10$$

Let \underline{u}^* be the control which minimizes H . Then

$$\underline{u}^* = \underline{u}^*(\underline{y}, \underline{p}, t) \quad 1-11$$

Hence,

$$H^*(\underline{y}, \underline{p}, t) = H(\underline{y}, \underline{p}, \underline{u}^*, t) < H(\underline{y}, \underline{p}, \underline{u}, t) \quad 1-12$$

for all $\underline{u} \neq \underline{u}^*$.

Step 3: Form the following canonical equations which describe the costate \underline{p} and the state \underline{y} .

$$\dot{y}_i = \frac{\partial H}{\partial p_i} \quad ; \quad i = 1, 2, \dots, n \quad 1-13$$

$$\dot{p}_i = - \frac{\partial H}{\partial y_i} \quad ; \quad i = 1, 2, \dots, n \quad 1-14$$

or, more succinctly,

$$\dot{y} = \frac{\partial H}{\partial p}$$
$$\dot{p} = - \frac{\partial H}{\partial y}$$

Step 4: Then, a necessary condition on the optimal control \underline{u}^0 , which minimizes the functional of Eq. 1-8, is that it also minimizes the Hamiltonian H of Eq. 1-9. Hence,

$$\underline{u}^*(y, p, t) = \underline{u}^0(t) \quad 1-17$$

represents a necessary condition.

In Refs. 3 and 6 sufficiency conditions are also given in the form of a Hamilton-Jacobi partial differential equation with split boundary conditions.

In the next Section it will become evident that the theory above may be used in order to determine the form of the optimal control function but not its exact time dependence or its dependence on the actual state of the system, i.e., the optimum feedback control problem.

1.5 The Optimal Minimum-Fuel Control Function

In this Section we utilize the theoretical results of Section 1.4 in order to determine the form of the optimal control function for minimum-fuel operation. For the minimum-fuel problem the functional F of Eq. 1-3 is a special form of the functional V of Eq. 1-8. It follows that for the minimum-fuel problem

$$L = \sum_{j=1}^r |u_j(t)|. \quad 1-18$$

We form the Hamiltonian H

$$H = \sum_{j=1}^r |u_j(t)| + \langle \dot{\underline{y}}, \underline{p} \rangle . \quad 1-19$$

Substituting Eq. 1-1 into 1-19 we obtain

$$H = \sum_{j=1}^r |u_j(t)| + \langle \underline{A}\underline{y}, \underline{p} \rangle + \langle \underline{B}\underline{u}, \underline{p} \rangle . \quad 1-20$$

The canonical equations 1-15 and 1-16 yield

$$\dot{\underline{y}} = \frac{\partial H}{\partial \underline{p}} = \underline{A}\underline{y} + \underline{B}\underline{u} \quad 1-21$$

$$\dot{\underline{p}} = -\frac{\partial H}{\partial \underline{y}} = -\underline{A}'\underline{p} \quad 1-22$$

where \underline{A}' is the transpose of matrix \underline{A} . Equation 1-21 is identical to Eq. 1-1, which describes the behavior of the state \underline{y} of the plant. Equation 1-22 is an ordinary homogeneous matrix differential equation, which has the solution

$$\underline{p}(t) = e^{-\underline{A}'t} \underline{p}(0) \triangleq e^{-\underline{A}'t} \underline{p}_0 . \quad 1-23$$

Equation 1-23 defines the time response of the costate \underline{p} . We shall refer to the system described by Eq. 1-22 as the adjoint system. Note that the costate $\underline{p}(t)$ is independent of the control $\underline{u}(t)$.

Now we must determine the control which absolutely minimizes the Hamiltonian H of Eq. 1-20. First, note that

$$\langle \underline{B}\underline{u}, \underline{p} \rangle = \langle \underline{u}, \underline{B}'\underline{p} \rangle . \quad 1-24$$

Let

$$\underline{q} = \{q_1, q_2, \dots, q_r\} = \underline{B}'\underline{p} = \underline{B}'e^{-\underline{A}'t}\underline{p}_0 \quad 1-25$$

Then

$$H^* = \min_{\substack{\underline{u}(t) \\ |u_j| \leq 1}} H = \min_{\substack{\underline{u}(t) \\ |u_j| \leq 1}} \left\{ \sum_{j=1}^r |u_j(t)| + \langle \underline{A}\underline{y}, \underline{p} \rangle + \sum_{j=1}^r u_j(t)q_j(t) \right\} \quad 1-26$$

Therefore,

$$H^* = \langle \underline{A}\underline{y}, \underline{p} \rangle + \sum_{j=1}^r \left\{ \min_{\substack{\underline{u}(t) \\ |u_j| \leq 1}} \{ |u_j(t)| + u_j(t)q_j(t) \} \right\} \quad 1-27$$

The above steps are justified since in the minimization procedure with respect to $\underline{u}(t)$, the state \underline{y} and the costate \underline{p} are to be treated as constants, and since the components $u_j(t)$ of the control $\underline{u}(t)$ are independent.

As is evident from Eq. 1-27, the evaluation of H^* hinges on the minimum of the quantity $\{ |u_j(t)| + u_j(t)q_j(t) \}$. Note that formal minimization techniques, i. e.,

$$0 = \frac{\partial}{\partial u_j} \left\{ |u_j(t)| + u_j(t)q_j(t) \right\} \quad 1-28$$

lead to

$$\text{sgn} \{u_j(t)\} + q_j(t) = 0 \quad 1-29$$

which is an unrealistic result because $\text{sgn}\{u_j(t)\} = \pm 1$ cannot equal some function of time. Thus, we are forced to determine the minimum of $\{ |u_j(t)| + u_j(t)q_j(t) \}$ by some other method.

Let

$$c_j(t) = |u_j(t)| + u_j(t)q_j(t) = |u_j(t)| + \text{sgn}\{q_j(t)\} u_j(t) |q_j(t)| \quad 1-30$$

Case 1: If $\text{sgn}\{q_j(t)\} = +1$.

(i) If $u_j(t) \geq 0$, then

$$c_j(t) = |u_j(t)| [1 + |q_j(t)|],$$

which implies

$$c_j(t) = 0, \text{ hence}$$

$$\min_{u_j} c_j(t) = 0 \text{ is obtained by}$$

$$u_j(t) = 0.$$

(ii) If $u_j(t) < 0$, then

$$c_j(t) = |u_j(t)| [1 - |q_j(t)|].$$

(a) If $[1 - |q_j(t)|] \geq 0$, then

$$c_j(t) \geq 0, \text{ hence}$$

$$\min_{u_j} c_j(t) = 0, \text{ obtained by}$$

$$u_j(t) = 0.$$

(b) If $[1 - |q_j(t)|] < 0$, then

$$c_j(t) < 0, \text{ hence}$$

$$\min_{u_j} c_j(t) = [1 - |q_j(t)|] \text{ is obtained by}$$

$$|u_j(t)| = 1.$$

Case 2: If $\text{sgn} \{q_j(t)\} = -1$.

(i) If $u_j(t) \geq 0$, then

$$c_j(t) = |u_j(t)| [1 - |q_j(t)|].$$

(a) If $[1 - |q_j(t)|] \geq 0$, then

$$c_j(t) \geq 0, \text{ hence}$$

$\min_{u_j} c_j(t) = 0$ is obtained by

$$u_j(t) = 0$$

(b) If $[1 - |q_j(t)|] < 0$, then

$$c_j(t) < 0, \text{ hence}$$

$\min_{u_j} c_j(t) = [1 - |q_j(t)|]$ is obtained by

$$|u_j(t)| = 1.$$

(ii) If $u_j(t) \leq 0$, then

$$c_j(t) = |u_j(t)| [1 + |q_j(t)|],$$

which implies

$$c_j(t) > 0, \text{ hence}$$

$\min_{u_j} = 0$ is obtained by

$$u_j(t) = 0.$$

From the above results one may state the following Theorem.

Theorem 1: For minimum-fuel control of the plant described by Eq. 1-1, and for control signals restricted by Eq. 1-2, the optimal control functions are determined by

$$\left. \begin{array}{ll}
 u_j(t) = 0 & \text{if } \operatorname{sgn}\{1 - |q_j(t)|\} = +1 \\
 u_j(t) = -\operatorname{sgn}\{q_j(t)\} & \text{if } \operatorname{sgn}\{1 - |q_j(t)|\} = -1 \\
 \text{for } j=1, 2, \dots, r & \text{and } q_j(t) \text{ defined by Eq. 1-25.}
 \end{array} \right\} 1-31$$

The above theorem states that the optimal control functions for minimum-fuel control must have the values +1, 0, or -1, as indicated by Eq. 1-31. Hence, the optimal control is piecewise constant. The magnitude and the polarity of each control signal depend on the costate \underline{p} , through Eq. 1-25, and hence, on the output of the adjoint system.

1.6 Discussion of the Results .

The results obtained in Section 1.5 are useful because they specify the form of the optimal control signals. The fact that each control $u_j(t)$ must be +1, 0, or -1 can be used in the preliminary design stage of a physical system. As an example, consider an attitude control system for which gas jets are to be used for control. Then, it is not necessary to build nozzles with intermediate settings but, rather, nozzles which open or close. Thus, the theory leads to a design which is simple and reliable from the mechanical point of view.

The results presented up to now cannot be used without additional work in the design of a practical control system. The reason is that each control signal $u_j(t)$ is a (nonlinear) function of the signal $q_j(t)$ which is a function of time and of the initial condition vector \underline{p}_0 of the adjoint system, since

$$\underline{q}(t) = \underline{B}' e^{-\underline{A}' t} \underline{p}_0 . \quad 1-32$$

Although the matrices \underline{B}' and \underline{A}' are known, the dependence of the constant vector \underline{p}_0 on the initial state \underline{y}_0 and the terminal state \underline{y}_f is not known. The conceptual block diagram of such a system is shown in Fig. 1. If for a given initial state \underline{y}_0 and terminal state \underline{y}_f the value of \underline{p}_0 could be determined, then the adjoint system could be built and its output, the costate $\underline{p}(t)$, after a linear transformation, would generate the q_1, q_2, \dots, q_r variables. The control law of Eq. 1.31 implies that u_1, u_2, \dots, u_r are obtained by passing q_1, q_2, \dots, q_r through nonlinear elements with the input-output characteristics of a relay with a dead-zone.

Additional information regarding the optimal control signals can be obtained from the plant described by Eq. 1-1. Suppose that in Eq. 1-1 the matrix \underline{A} has n distinct, real, and negative eigenvalues. We denote these eigenvalues by λ_i , $i = 1, 2, \dots, n$. Then, it is well known that each component $p_i(t)$ of the costate $\underline{p}(t)$ will have the form

$$p_i(t) = \sum_{k=1}^n \alpha_{ik} e^{-\lambda_k t} \quad ; \quad i=1, 2, \dots, n \quad 1-33$$

where the constants α_{ik} will be functions of the eigenvalues $\lambda_1, \lambda_2, \dots, \lambda_n$ and of the initial conditions $p_{10}, p_{20}, \dots, p_{n0}$. From Eq. 1-25 we can determine that each signal $q_j(t)$ will be of the form

$$q_j(t) = \sum_{k=1}^n \beta_{jk} e^{-\lambda_k t} \quad ; \quad j=1, 2, \dots, r \quad 1-34$$

where the constants β_{jk} are functions of the α_{ik} and b_{ij} . Since the λ_k 's were assumed to be real, negative, and distinct, it is well known that each function $q_j(t)$

is zero at most $n-1$ times. Then, it is clear that the control signal $u_j(t)$ will be zero at most $n-1$ times. However, if the function $q_j(t)$ changes sign exactly m times, $0 \leq m \leq n-1$, then the control $u_j(t)$ will be zero at most m times.

If some of the eigenvalues of \underline{A} are complex numbers with non-positive real parts, then there is no upper bound on the times that each signal $q_j(t)$ will change sign; hence, there exists no bound on the times that each control $u_j(t)$ is zero.

Each function $q_j(t)$ is continuous. From Eq. 1-31 and the continuity of each $q_j(t)$, we conclude that control sequences of the form

$$u_j(t) = \begin{cases} +1 & 0 \leq t < t_1 \\ -1 & t_1 \leq t < t_2 \\ \text{etc.} & \end{cases} \quad 1-35$$

cannot be optimal, since there must exist a finite interval of time during which the control $u_j(t)$ is zero. In other words, if at present $u_j(t) = +1$ is the correct control, and if at some time in the future $u_j(t) = -1$ is required, the change of the control signal from $+1$ to -1 cannot be instantaneous but the control must be zero for some finite time before it can jump to -1 . However, control sequences of the form

$$u_j(t) = \begin{cases} +1 & 0 \leq t < t_1 \\ 0 & t_1 \leq t < t_2 \\ +1 & t_2 \leq t < t_3 \\ \text{etc.} & \end{cases} \quad 1-36$$

can be optimal.

1.7 Uniqueness of the Optimal Control .

In this section we will discuss the uniqueness of the optimal control functions. In general, there exists more than one control function which will force the plant from an initial state to a terminal state using the same minimum amount of fuel. Each of these fuel-optimal controls will require a certain amount of time. We will show that the theory developed will lead to the control function which requires not only the least amount of fuel but, in addition, the least amount of time.

In this Section we were concerned with the minimization of the functional

$$F = \int_0^{t_f} \left\{ \sum_{j=1}^r |u_j(t)| \right\} dt \quad 1-37$$

Consider the minimization of the functional

$$J = \int_0^{t_f} dt + \int_0^{t_f} \left\{ \sum_{j=1}^r |u_j(t)| \right\} dt \quad 1-38$$

which implies the minimization of the sum of the response time and of the fuel required. The Hamiltonian corresponding to Eq. 1-38, is

$$H' = 1 + \sum_{j=1}^r |u_j(t)| + \langle \underline{A} \underline{y}, \underline{p} \rangle + \langle \underline{B} \underline{u}, \underline{p} \rangle . \quad 1-39$$

The minimization of the Hamiltonian H' , given by Eq. 1-39, with respect to the control $\underline{u}(t)$, leads to the control law given by Eq. 1-31, which was obtained from the minimization of the Hamiltonian given by Eq. 1-20. Thus, it is apparent that the

control law of Eq. 1-31 will result in a control function which will force the plant from an initial state to a final state using the least amount of fuel and requiring the least amount of time. An example of the above theory is given in Section 3.5.

1.8 The Time-Varying Case.

We have derived the optimal control law for time-invariant plants. In this Section we shall show that the results obtained carry through to the case of time-varying plants.

If the controlled plant is time-varying but linear, then its matrix differential equation is

$$\dot{\underline{y}} = \underline{A}(t)\underline{y}(t) + \underline{B}(t)\underline{u}(t) , \quad 1-40$$

The Hamiltonian is

$$H = \sum_{j=1}^r |u_j(t)| + \langle \underline{A}(t)\underline{y}, \underline{p} \rangle + \langle \underline{B}(t)\underline{u}, \underline{p} \rangle . \quad 1-41$$

The adjoint system satisfies the differential equation

$$\dot{\underline{p}}(t) = -\underline{A}'(t)\underline{p}(t) . \quad 1-42$$

If we define

$$\underline{q}(t) = \underline{B}'(t)\underline{p}(t) ,$$

then the optimal control law is the one given by Eq. 1-31. However, since the matrices $\underline{A}(t)$ and $\underline{B}(t)$ are functions of time, the comments of Section 1.6 regarding the number

of changes of the vector $\underline{p}(t)$ and $\underline{q}(t)$ are not valid.

1. 9 Summary and Conclusions.

In this chapter we have used the general theory of optimal control systems in order to determine the form of the optimal control for minimum-fuel operation. We have found that each control signal must be +1, 0, or -1, and that the exact time response of each control signal depends on the output of the adjoint system.

2. MINIMUM FUEL CONTROL OF A SINGLE INPUT PLANT

2.1 Introduction.

In this Section we will examine the minimum fuel control of a plant described by a transfer function $G(s)$ containing no zeroes. The input to the plant is the (single) control $u(t)$. The similarity transformation will be used in order to determine a more convenient set of state variables.

2.2 Definitions and Terminology.

We wish to control a plant described by the transfer function

$$G(s) = \frac{1}{(s-\lambda_1)(s-\lambda_2)\dots(s-\lambda_n)} \quad 2-1$$

Let $y_1(t)$ be the output of the plant and let $u(t)$ be the input signal, i. e., the control, to the plant. Assume that the control signal is bounded by unity,

$$|u(t)| \leq 1 \quad 2-2$$

The output $y_1(t)$ and the control $u(t)$ are related by the n -th order differential equation

$$(D - \lambda_1)(D - \lambda_2) \dots (D - \lambda_n) y_1(t) = u(t) \quad 2-3$$

or

$$\{D^n + a_{n-1}D^{n-1} + \dots + a_1D + a_0\} y_1(t) = u(t) \quad 2-4$$

where $D \triangleq \frac{d}{dt}$ is the differential operator.

Now we will define a set of variables such that the differential equation 2-4 will be in the form of Eq. 1-1. Let

$$y_i(t) \triangleq D^{i-1} y_1(t) \quad ; \quad i=1, 2, \dots, n \quad 2-5$$

Using Eqs. 2-5 and 2-4, we may write the matrix differential equation

$$\begin{bmatrix} \dot{y}_1 \\ \dot{y}_2 \\ \cdot \\ \cdot \\ \dot{y}_n \end{bmatrix} = \begin{bmatrix} 0 & 1 & 0 & \cdot & \cdot & \cdot & 0 \\ 0 & 0 & 1 & \cdot & \cdot & \cdot & 0 \\ \cdot & \cdot & \cdot & \cdot & \cdot & \cdot & \cdot \\ \cdot & \cdot & \cdot & \cdot & \cdot & \cdot & \cdot \\ -a_0 & -a_1 & -a_2 & \cdot & \cdot & \cdot & -a_{n-1} \end{bmatrix} \begin{bmatrix} y_1 \\ y_2 \\ \cdot \\ \cdot \\ y_n \end{bmatrix} + \begin{bmatrix} 0 \\ 0 \\ \cdot \\ \cdot \\ u(t) \end{bmatrix} \quad 2-6$$

which is of the form

$$\dot{\underline{y}} = \underline{A}\underline{y} + \underline{B}u(t) \quad 2-7$$

where the n-vector \underline{y} is defined by Eq. 2-5 and its elements are the output $y_1(t)$ and n-1 of its time derivatives. The matrix \underline{A} is defined by 2-6. The matrix \underline{B} is the identity matrix and the column vector $\underline{u}(t)$ is

$$\underline{u}(t) = \begin{bmatrix} 0 \\ 0 \\ \cdot \\ \cdot \\ \cdot \\ 0 \\ u(t) \end{bmatrix} \quad 2-8$$

Now we will use the well-known similarity transformation in order to define a new set of variables. Assume that the poles $\lambda_1, \lambda_2, \dots, \lambda_n$ of the transfer function $G(s)$ are distinct. Note that the eigenvalues of the matrix \underline{A} are also $\lambda_1, \lambda_2, \dots, \lambda_n$. Then there exists a diagonal matrix $\underline{\Lambda}$ of the form

$$\underline{\Lambda} = \begin{bmatrix} & & & & & & \\ & \lambda_1 & & & & & \\ & & \lambda_2 & & & & \\ & & & \cdot & & & \\ & & & & \cdot & & \\ & & & & & \cdot & \\ & & & & & & \lambda_n \end{bmatrix} \quad 2-9$$

and a nonsingular matrix \underline{P} of the form (the Vandermonde matrix)

$$\underline{P} = \begin{bmatrix} 1 & 1 & \cdot & \cdot & \cdot & 1 \\ \lambda_1 & \lambda_2 & \cdot & \cdot & \cdot & \lambda_n \\ \lambda_1^2 & \lambda_2^2 & \cdot & \cdot & \cdot & \lambda_n^2 \\ \cdot & \cdot & \cdot & \cdot & \cdot & \cdot \\ \cdot & \cdot & \cdot & \cdot & \cdot & \cdot \\ \cdot & \cdot & \cdot & \cdot & \cdot & \cdot \\ \lambda_1^{n-1} & \lambda_2^{n-1} & \cdot & \cdot & \cdot & \lambda_n^{n-1} \end{bmatrix} \quad 2-10$$

such that

$$\underline{\Lambda} = \underline{P}^{-1} \underline{A} \underline{P} \quad . \quad 2-11$$

Define a new set of variables x_1, x_2, \dots, x_n by

$$\underline{x} = \underline{P}^{-1} \underline{y} \quad 2-12$$

Then, it is easy to show that the \underline{x} variables satisfy the matrix differential equation

$$\dot{\underline{x}} = \underline{\Lambda} \underline{x} + \underline{P}^{-1} \underline{u}(t) \quad . \quad 2-13$$

Let the n -th column of the matrix \underline{P}^{-1} be the column vector $\underline{r} = (r_1, r_2, \dots, r_n)$.

Then, Eq. 2-13 together with Eq. 2-8 yield

$$\dot{x}_i = \lambda_i x_i + r_i u(t) \quad ; \quad i=1, 2, \dots, n \quad 2-14$$

It is easy to show that the constant r_i is the residue at the pole λ_i of the transfer function $G(s)$, i.e.,

$$r_i = \frac{1}{(\lambda_i - \lambda_1) \dots (\lambda_i - \lambda_{i-1}) (\lambda_i - \lambda_{i+1}) \dots (\lambda_i - \lambda_n)} \quad . \quad 2-15$$

Physically, each variable x_i is a linear combination of y_1, y_2, \dots, y_n as indicated by Eq. 2.12.

If some of the eigenvalues (or poles) λ_i are the same, then the $\underline{\Lambda}$ matrix is not diagonal, but it is of the Jordan-Canonical form.[‡]

[‡] B. Friedman "Principles and Techniques of Applied Mathematics", J. Wiley and Sons, New York, 1956, pp 76-89.

In this section we have defined, for future ease of computation, a new set of variables which in the rest of this Section we will use as the state variables. Note that each value of the \underline{y} -variables yields a unique value for the \underline{x} -variables and vice-versa.

2.3 Minimum-Fuel Control.

The problem which we want to solve is: Given an initial value of the output and $n-1$ of its time derivatives, i. e., an initial state \underline{y}_0 , and a desired fixed terminal state \underline{y}_f , then determine a control $u(t)$, $|u(t)| \leq 1$, which will force the plant from \underline{y}_0 to \underline{y}_f and which will minimize the functional

$$F = \int_0^{t_f} |u(t)| dt \quad . \quad 2-16$$

The initial condition \underline{y}_0 will define a initial state \underline{x}_0 using Eq. 2-12. Similarly, the terminal state \underline{y}_f will define a terminal state \underline{x}_f . Hence, the problem of minimum-fuel control may be restated as follows: Find the control $u(t)$, $|u(t)| \leq 1$, which will force a system described by Eq. 2-14 from an initial state \underline{x}_0 to a fixed terminal state \underline{x}_f such that the performance index of Eq. 2-16 is minimum.

For the sake of brevity, define $\underline{\xi} = (\xi_1, \xi_2, \dots, \xi_n)$

$$\underline{\xi} \triangleq \underline{x}_0 \quad . \quad 2-17$$

The Hamiltonian for this problem is

$$H = |u(t)| + \langle \underline{\Lambda} \underline{x}, \underline{p} \rangle + u(t) \langle \underline{r}, \underline{p} \rangle \quad 2-18$$

or

$$H = |u(t)| + \sum_{j=1}^n \lambda_j x_j p_j + u(t) \sum_{j=1}^n r_j p_j \quad 2-19$$

The costate \underline{p} is defined by

$$\dot{\underline{p}} = - \frac{\partial H}{\partial \underline{x}} = - \underline{\Lambda}' \underline{p} = - \underline{\Lambda} \underline{p} \quad 2-20$$

hence,

$$\dot{p}_i(t) = - \lambda_i p_i(t) \quad ; \quad i=1, 2, \dots, n \quad 2-21$$

For the sake of brevity, define $\underline{\eta} = (\eta_1, \eta_2, \dots, \eta_n)$.

$$\underline{\eta} \triangleq \underline{p}(0) \quad 2-21a$$

Then, solution of 2-21 yields

$$p_i(t) = \eta_i e^{-\lambda_i t} \quad i=1, 2, \dots, n \quad 2-22$$

To minimize the Hamiltonian H , we follow the steps in Section 1.5 and find the optimal control law.

$$\left. \begin{aligned} u(t) &= 0 & \text{if} & \quad \text{sgn} \{1 - |q(t)|\} = +1 \\ u(t) &= -\text{sgn}\{q(t)\} & \text{if} & \quad \text{sgn} \{1 - |q(t)|\} = -1 \end{aligned} \right\} \quad 2-23$$

$$q(t) \triangleq \sum_{i=1}^n r_i p_i(t) = \sum_{i=1}^n r_i \eta_i e^{-\lambda_i t} \quad 2-24$$

Thus, the control signal $u(t)$ must be +1, 0, or -1 in order to accomplish a given control action with a minimum amount of fuel. The comments of Section 1.6 apply in this case too.

2.4 Evaluation of the Hamiltonian.

In this Section we shall show that the Hamiltonian defined by Eq. 2-18 is a constant scalar function if the control law Eq. 2-23 is used.

Consider the equation of the x -variables

$$\dot{x}_i = \lambda_i x_i + r_i u(t) \quad 2-25$$

Case 1: If

$$u(t) = 0 \quad 2-26$$

then

$$x_i(t) = \xi_i e^{\lambda_i t} \quad ; \quad i = 1, 2, \dots, n \quad 2-27$$

Hence, the Hamiltonian H , using Eqs. 2-26, 2-27, and 2-22, is

$$H = \sum_{i=1}^n \lambda_i x_i p_i = \sum_{i=1}^n \lambda_i \xi_i e^{\lambda_i t} \eta_i e^{-\lambda_i t} = \sum_{i=1}^n \lambda_i \xi_i \eta_i \quad 2-28$$

which is a constant.

Case 2: If

$$u(t) = \Delta = \pm 1$$

then

$$x_i(t) = \left[\xi_i + \frac{r_i}{\lambda_i} \Delta \right] e^{\lambda_i t} - \frac{r_i}{\lambda_i} \Delta \quad 2-30$$

for $i = 1, 2, \dots, n$.

Hence, the Hamiltonian is

$$H = |\Delta| + \sum_{i=1}^n \lambda_i x_i p_i + \Delta \sum_{i=1}^n r_i p_i \quad 2-31$$

and after some manipulation,

$$H = 1 + \sum_{i=1}^n \lambda_i \xi_i \eta_i + \Delta \sum_{i=1}^n r_i \eta_i \quad 2-32$$

From Eqs. 2-28 and 2-32 we conclude that during the response of a minimum fuel system, the Hamiltonian is piecewise constant. From Theorem 5 of Ref. 6, which states that the Hamiltonian must be continuous and piecewise differentiable, it follows that the Hamiltonian is a constant.

2.5 Discussion of the Results

The unknown relationship between the initial conditions η_i of the adjoint system and of the initial states ξ_i of the controlled plant makes the actual design of a minimum-fuel control system impossible without additional work. It is expected that the difficulties encountered in the design of minimum time (or bang-bang) control systems will also be found in the design of minimum-fuel systems. The author has shown in Ref. 7 that for the minimum time problem, the relation between the state of the plant and that of the adjoint system cannot be found unless the problem of control has been completely solved using the concept of switching sets. In the case of the minimum time problem, the concept of the switching sets has been used to advantage.

In the following two Sections we will examine two second-order systems and

design the minimum fuel control using geometrical concepts. The design is not carried out in terms of the adjoint system, but the results obtained in Sections 1 and 2 are fully exploited in order to simplify the arguments which are based on the geometrical point of view.

In addition to the comments and conclusions of Section 1.6, the following conclusions may also be obtained.

Suppose that all the eigenvalues (or poles) $\lambda_1, \lambda_2, \dots, \lambda_n$ are either negative or have negative real parts. If the desired final state is the origin of the y (or x) state space, that is, we wish to bring the output and its $n-1$ time derivatives to zero, then $u(t) = 0$ is the optimal control. This is due to the fact that such a plant will always dissipate energy and, theoretically, after an infinite amount of time, the output and all of its derivatives will become zero. Since $u(t) = 0$ was used, there is no fuel consumed. If we examine the costate \underline{p} in Eq. 2-22, we observe that each term of the form $e^{-\lambda_i t}$ will become infinite for any $\eta_i \neq 0$. Since physical considerations lead to the conclusion that $u(t) = 0$ must be used in order to reach the origin, it follows that for this problem $\eta_1 = \eta_2 = \dots = \eta_n = 0$. In short:

(I) If $\text{Re}[\lambda_i] < 0$, $i=1, 2, \dots, n$, and if $\underline{y}_f = 0$, then $u(t) = 0$, $0 \leq t \leq \infty$, leads to $F = 0$, which implies that $\eta_i = 0$, for all $i=1, 2, \dots, n$, hence $p_i(t) = 0$, for all i .

Now suppose that the terminal point is not the origin, but is a point of the solution of the homogeneous matrix differential equation $\dot{\underline{y}} = \underline{A}\underline{y}$ or $\dot{\underline{x}} = \underline{\Lambda}\underline{x}$, which implies that

$$\underline{y}_f = e^{\underline{A}t_f} \underline{y}_0 \quad 2-33$$

or

$$\underline{x}_f = e^{\frac{\Lambda t_f}{\xi}} .$$

2-34

Once more, physical considerations lead to the result that $u(t) = 0$ is the optimal control in the interval $0 \leq t \leq t_f$ since no fuel is used. There is no restriction on the eigenvalues λ_i . Then, since t_f may be quite large, the initial conditions of the adjoint system must be zero, i. e., $\eta_i = 0$, for all $i = 1, 2, \dots, n$, which implies that $p_i(t) = 0$ for all $i = 1, 2, \dots, n$ and all t , $0 \leq t \leq t_f$. In short:

(II) If $\underline{x}_f = e^{\frac{\Lambda t_f}{\xi}}$, then $u(t) = 0$, $0 \leq t \leq t_f$, leads to $F = 0$, which implies that $\eta_i = 0$, for all $i = 1, 2, \dots, n$, and $p_i(t) = 0$, for all $i = 1, 2, \dots, n$, and all t in the interval $0 \leq t \leq t_f$.

3. MINIMUM-FUEL CONTROL OF A DOUBLE INTEGRAL PLANT

3.1 Introduction.

In this Section we will examine in detail the optimal minimum-fuel control of a plant with the transfer function $G(s) = 1/s^2$, which in the control literature is known as a double-integral plant. Using the phase plane as a guide, the actual design of the controller will be obtained.

3.2 The Equations of Motion.

We assume that the controlled plant has the transfer function

$$G(s) = \frac{1}{s^2} \quad . \quad 3.1$$

Let $x_1(t)$ be the output and $u(t)$ be the input (and control) signal. Assume that

$$|u(t)| \leq 1 \quad . \quad 3.2$$

Define

$$x_2(t) = \frac{dx_1(t)}{dt} \quad . \quad 3.3$$

Since the plant is governed by the differential equation

$$\frac{d^2 x_1(t)}{dt^2} = u(t), \quad 3.4$$

then the states x_1 and x_2 satisfy the matrix differential equation.

$$\begin{bmatrix} \dot{x}_1 \\ \dot{x}_2 \end{bmatrix} = \begin{bmatrix} 0 & 1 \\ 0 & 0 \end{bmatrix} \begin{bmatrix} x_1 \\ x_2 \end{bmatrix} + \begin{bmatrix} 0 \\ u(t) \end{bmatrix} ; \quad \begin{array}{l} x_1(0) = \xi_1 \\ x_2(0) = \xi_2 \end{array} \quad 3.5$$

Equation 3.5 is in the Jordan Canonical form; hence, no further transformation of variables is necessary .

The fuel consumed is given by

$$F = \int_0^{t_f} |u(t)| dt . \quad 3.6$$

The adjoint system satisfies the differential equation

$$\begin{bmatrix} \dot{p}_1 \\ \dot{p}_2 \end{bmatrix} = \begin{bmatrix} 0 & 0 \\ -1 & 0 \end{bmatrix} \begin{bmatrix} p_1 \\ p_2 \end{bmatrix} ; \quad \begin{aligned} p_1(0) &= \eta_1 \\ p_2(0) &= \eta_2 \end{aligned} \quad 3.7$$

which we may solve readily and obtain

$$\begin{aligned} p_1(t) &= \eta_1 = \text{constant} \\ p_2(t) &= \eta_2 - \eta_1 t \end{aligned} \quad 3.8$$

The optimal control law is

$$\left. \begin{aligned} u(t) &= 0 & \text{if} & \quad \text{sgn}\{1 - |p_2(t)|\} = +1 \\ u(t) &= -\text{sgn}\{p_2(t)\} & \text{if} & \quad \text{sgn}\{1 - |p_2(t)|\} = -1 \end{aligned} \right\} \quad 3.9$$

Hence, for minimum fuel control

$$\left. \begin{aligned} u(t) &= 0 & \text{or} \\ u(t) &= \Delta = \pm 1. \end{aligned} \right\} \quad 3.10$$

Now we may solve Eq. 3-5.

Case 1: If $u(t) = 0$, then

$$\left. \begin{aligned} x_1(t) &= \xi_1 + \xi_2 t \\ x_2(t) &= \xi_2 \end{aligned} \right\} \quad 3.11$$

Case 2: If $u(t) = \Delta = \pm 1$, then

$$\left. \begin{aligned} x_1(t) &= \xi_1 + \xi_2 t + \frac{1}{2} \Delta t^2 \\ x_2(t) &= \xi_2 + \Delta t \end{aligned} \right\} \quad 3.12$$

The time t may be eliminated in Eqs. 3-11 and 3-12, and the response of the system may be described by trajectories in the $x_1 - x_2$ phase plane. The arrows on the trajectories indicate direction of motion for positive time. In Fig. 2 the trajectories, for $u(t) = 0$, are shown. The trajectories are straight lines for which $x_2 = \text{constant}$. Eliminating the time t from Eq. 3-12, we obtain the trajectory equations

$$x_1 = \xi_1 + \frac{1}{2} \Delta x_2^2 - \frac{1}{2} \Delta \xi_2^2 \quad 3-13$$

The above trajectories are parabolas in the $x_1 - x_2$ plane. They are illustrated in Fig. 3. The solid curves are for $\Delta = +1$, while the broken curves are for $\Delta = -1$.

3.3 Information From the Adjoint System.

From Eq. 3-9 it is quite evident that the control depends on the function $p_2(t)$. From Eq. 3-8

$$p_2(t) = \eta_2 - \eta_1 t \quad 3-14$$

and since η_2 and η_1 are (unknown) constants, it is clear that Eq. 3-14 is the equation

of a straight line. In Fig. 4 six different "shapes" of the function $p_2(t)$ are shown for different ranges of the constants η_1 and η_2 . Using Fig. 4 and Eq. 3-9, we conclude that the following control functions are optimal.

$$u(t) = \begin{cases} 0 & 0 \leq t < t_1 \\ -1 & t_1 \leq t \leq t_f \end{cases}, \quad 3-15$$

$$u(t) = \begin{cases} 0 & 0 \leq t < t_1 \\ +1 & t_1 \leq t \leq t_f \end{cases}, \quad 3-16$$

$$u(t) = \begin{cases} +1 & 0 \leq t < t_1 \\ 0 & t_1 \leq t < t_2 \\ -1 & t_2 \leq t \leq t_f \end{cases}, \quad 3-17$$

$$u(t) = \begin{cases} -1 & 0 \leq t < t_1 \\ 0 & t_1 \leq t < t_2 \\ +1 & t_2 \leq t \leq t_f \end{cases}, \quad 3-18$$

$$u(t) = 0 \quad 0 \leq t \leq t_f \quad 3-18a$$

$$u(t) = -1 \quad 0 \leq t \leq t_f \quad 3-19$$

and

$$u(t) = +1 \quad 0 \leq t \leq t_f \quad 3-20$$

We have found that examination of the costate as a function of time has resulted in six possible forms of the optimal control function. The times t_1, t_2 , and t_f in the above equations are usually not the same. We shall call control signals of

the same type as those given by Eqs. 3-15 through 3-20 allowable.

3.4 The Origin as the Terminal Point.

In this Section we consider the problem of reaching the origin of the $x_1 - x_2$ phase plane from any initial condition with a minimum amount of fuel.

Consider all points in the phase plane $x_1 - x_2$ with the property that if $u(t) = 0$ is applied, then the resulting trajectory will pass through the origin. We let $x_1 = x_2 = 0$ in Eq. 3-11 and we obtain the equations

$$\begin{aligned} \xi_1 + \xi_2 t &= 0 \\ \xi_2 &= 0 \end{aligned} \quad , \quad 3-21$$

hence,

$$\xi_1 = \xi_2 = 0. \quad 3-22$$

We conclude that the only point from which one may reach the origin using $u(t) = 0$ is the origin itself.

Consider all points in the phase plane from which one may reach the origin using $u(t) = +1$. Substituting $\Delta = +1$, $x_1 = x_2 = 0$ in Eq. 3-13, we obtain

$$\xi_1 = \frac{1}{2} \xi_2^2 \quad 3-23$$

Since the motion must be for positive time, Eq. 3-23 is valid only in the region

$$\xi_1 \geq 0 \quad ; \quad \xi_2 \leq 0 \quad 3-24$$

The curve defined by Eq. 3-23 and 3-24 is shown in Fig. 5 and it is denoted as the γ_+ curve.

Consider all points in the phase plane from which one may reach the origin using $u(t) = -1$. Substituting $\Delta = -1$, $x_1 = x_2 = 0$ in Eq. 3-13, we obtain

$$\xi_1 = -\frac{1}{2} \xi_2^2 \quad 3-25$$

Since the motion must be for positive time only, Eq. 3-25 is valid only in the region

$$\xi_1 \leq 0 \quad ; \quad \xi_2 \geq 0 \quad 3-26$$

The curve defined by Eqs. 3-25 and 3-26 is referred to as the γ_- curve and is shown in Fig. 5.

Now we will establish the optimality of the curves γ_+ and γ_- using the results of Section 3.3; that is, we shall show that, if $(\xi_1, \xi_2) \in \gamma_+$, then $u(t) = +1$ is the optimal control policy and if $(\xi_1, \xi_2) \in \gamma_-$, then $u(t) = -1$ is the optimal policy. Suppose that (ξ_1, ξ_2) is on the γ_+ curve; then the allowable controls are given by Eqs. 3-15 through 3-20. It is easy to see, using Fig. 2 and Fig. 3, that any control of the form of Eqs. 3-15 through 3-19 will not bring the state (ξ_1, ξ_2) to the origin. Hence, $u(t) = +1$ is optimal, and the optimality of γ_+ has been established. One may use the same argument and show that if $(\xi_1, \xi_2) \in \gamma_-$, then $u(t) = -1$ is the optimal control policy; hence γ_- is an optimal minimum fuel trajectory. To recapitulate:

If $(\xi_1, \xi_2) \in \gamma_+$, then the control $u(t) = +1$ will force the state to $(0, 0)$ with a minimum amount of fuel. If $(\xi_1, \xi_2) \in \gamma_-$, then the control $u(t) = -1$ will force the state to $(0, 0)$ with a minimum amount of fuel.

Consider Region IV in Fig. 5 defined by

$$\left. \begin{aligned} x_1 &> \frac{1}{2} x_2^2 \\ x_1 &> 0 \quad ; \quad x_2 < 0 \end{aligned} \right\} \quad 3.27$$

Suppose that the initial state (ξ_1, ξ_2) is in Region IV. Consider the allowable controls given by Eqs. 3-15 through 3-20. It is easy to conclude that controls of the type given by Eqs. 3-15, 3-17, 3-19, and 3-20, cannot transfer the state point (ξ_1, ξ_2) to the origin. Thus, we must consider the allowable controls defined by Eqs. 3-16 and 3-18. The control function described by Eq. 3-16 implies that $u(t) = 0$ must be applied until the state point is on the γ_+ curve and $u(t) = +1$ from the point of intersection until the origin is reached. This control policy results in the trajectory ABO in Fig. 6. The control function given by Eq. 3-18 will result in a trajectory of the form of ACDO in Fig. 6. Now we shall show that for any (ξ_1, ξ_2) in Region IV, the optimal policy is to use $u(t) = 0$ until the state point is forced on the γ_+ curve and then to apply $u(t) = 1$.

The fuel consumed in order to bring the point $A = (\xi_1, \xi_2)$, in Fig. 6, to the point B on γ_+ is

$$F_{AB} = 0 \quad 3-28$$

since $u(t) = 0$ was used. The time required to take point B to the origin O using $u(t) = 1$ is, from Eq. 3-12,

$$t_{AB} = -\xi_2 = |\xi_2| \quad 3-29$$

Hence, the fuel to take point B to the origin is

$$F_{BO} = \int_0^{t_{AB}} |1| dt = t_{AB} = |\xi_2| \quad 3-30$$

Hence, the total fuel consumed in order to bring point A = (ξ_1, ξ_2) to the origin is

$$F_{ABO} = F_{AB} + F_{BO} = |\xi_2| \quad 3-31$$

Now consider the trajectory ACDO in Fig. 6. Let point C have the coordinates

C = (ξ'_1, ξ'_2). Then point D has the coordinates D = (ξ''_1, ξ'_2). Clearly

$$\xi'_2 < \xi_2, \quad \text{or,} \quad |\xi'_2| > |\xi_2| \quad 3-32$$

From Eq. 3-12

$$t_{AC} = \xi_2 - \xi'_2 \quad 3-33$$

and

$$t_{DO} = -\xi_2 \quad 3-34$$

Therefore,

$$F_{AC} = |\xi'_2| - |\xi_2| \quad 3-35$$

$$F_{CD} = 0 \quad 3-35a$$

$$F_{DO} = |\xi'_2| \quad 3-36$$

Hence, the total fuel along the trajectory ACDO is

$$F_{ACDO} = |\xi_2'| - |\xi_2| + |\xi_2'| = 2|\xi_2'| - |\xi_2| \quad 3.37$$

and it is clear, because of Eq. 3-32, that

$$F_{ABO} < F_{ACDO} . \quad 3.38$$

The conclusion is:

If (ξ_1, ξ_2) is in Region IV, defined by Eq. 3-27, then, for minimum fuel control apply $u(t) = 0$ until the curve γ_+ is reached and then apply $u(t) = +1$.

Consider Region II in Fig. 5. Region II is defined by

$$\left. \begin{aligned} x_1 &< -\frac{1}{2} x_2^2 \\ x_1 &< 0 \quad ; \quad x_2 > 0 \end{aligned} \right\} \quad 3.39$$

Using identical arguments as above, one may draw the conclusion:

If (ξ_1, ξ_2) is in Region II, defined by Eq. 3-39, then, for minimum fuel control, apply $u(t) = 0$ until the curve γ_- is reached and then apply $u(t) = -1$.

The trajectory EGO in Fig. 6 is an example of a minimum-fuel trajectory.

We consider points in Region I, defined by

$$\left. \begin{aligned} x_1 &> -\frac{1}{2} x_2^2 \\ x_2 &\geq 0 \end{aligned} \right\} . \quad 3-40$$

Examine Eqs. 3-15 through 3-20. From Figs. 2 and 3 it is apparent that controls of the type given by Eqs. 3-15, 3-16, 3-17, 3-19, and 3-20, cannot force the state point

to the origin. The only type of control left is that of Eq. 3-18 which is

$$u(t) = \begin{cases} -1 & 0 \leq t < t_1 \\ 0 & t_1 \leq t < t_2 \\ +1 & t_2 \leq t \leq t_f \end{cases} \quad 3-41$$

The time t_1 at which the control changes from -1 to 0 must be such that the state point is in Region IV. Otherwise, the state point cannot be forced to the origin.

Furthermore, for minimum fuel control it is easy to see that the control must change from -1 to 0 at a point $(\xi'_1, -\delta)$, where δ is a very small positive number. In Fig. 6 the trajectory HJIO is optimal. The control $u(t) = -1$ forces the state from $H = (\xi_1, \xi_2)$ to $J = (\xi'_1, -\delta)$. At J the control $u(t) = 0$ is applied, which forces the state from $J = (\xi'_1, -\delta)$ to $I = (\xi''_1, -\delta)$. The point I is on the curve γ_+ . Hence, application of $u(t) = +1$ will force the state from I to the origin. It is easy to verify that the fuel consumed is

$$F_{HJIO} = |\xi_2| + 2\delta \approx |\xi_2| \quad 3-42$$

since δ is a very small positive number. Hence, we arrive at the following conclusion:

If (ξ_1, ξ_2) is in Region I, defined by Eq. 3-40, then the optimal control policy is to apply $u(t) = -1$ until the state point just enters Region IV, defined by Eq. 3-27, then apply $u(t) = 0$ which will force the state to the curve γ_+ ; at the instant the state is on γ_+ , apply $u(t) = +1$ in order to force it to the origin.

Finally, we consider initial conditions in Region III, defined by

$$\left. \begin{array}{l} x_1 < \frac{1}{2} x_2^2 \\ x_2 \leq 0 \end{array} \right\} \quad 3-43$$

Using similar arguments as above, we draw the conclusion.

If (ξ_1, ξ_2) is in Region III, defined by Eq. 3-43, apply $u(t) = +1$ until the state is forced into Region II; apply $u(t) = 0$ until the state is forced onto the γ curve, and apply $u(t) = -1$ in order to bring the state to the origin.

The trajectory KLMO, in Fig. 6, illustrates this policy.

The above results are summarized in Table 1.

TABLE I

Initial Conditions in	Optimal Control for Minimum Fuel.
Region I	(1) Apply $u(t) = -1$ to just enter Region IV (2) Apply $u(t) = 0$ to go to γ_+ curve (3) Apply $u(t) = +1$ to go to $(0^+, 0)$.
Region II	(1) Apply $u(t) = 0$ to go to γ_- curve (2) Apply $u(t) = -1$ to go to $(0, 0)$.
Region III	(1) Apply $u(t) = +1$ to just enter Region II (2) Apply $u(t) = 0$ to go to γ_- curve (3) Apply $u(t) = -1$ to go to $(0, 0)$.
Region IV	(1) Apply $u(t) = 0$ to go to γ_+ curve (2) Apply $u(t) = +1$ to go to $(0, 0)$.
γ_+	Apply $u(t) = +1$ to go to $(0, 0)$.
γ_-	Apply $u(t) = -1$ to go to $(0, 0)$.

3.3 The Non-Uniqueness of the Optimal Control Function.

In the previous Section we have arrived at a method of control based on the values of the state variables. The control functions thus defined will bring the state to the origin using a minimum amount of fuel.

Now we will pose the question: Do there exist other control functions which will bring the state point to the origin using the same minimum fuel but different response times? The answer to this question is YES. To illustrate the point, we consider Fig. 7. Suppose that our initial point is at $A = (1, -1)$. Consider the admissible controls which lead to the trajectories ABO, ADEO, and AFGO. The trajectory ABO is obtained through the use of the theory of the previous section, i. e., $u(t) = 0$ in the segment AB and $u(t) = +1$ in the segment BO. The trajectory ADEO is obtained by using $u(t) = +1$ in the segment AD, $u(t) = 0$ in the segment DE, and $u(t) = +1$ in the segment EO. This control sequence $+1, 0, +1$ is a violation of the control suggested from the adjoint system. Similarly, the trajectory AFGO is obtained by using $u(t) = +1$ in the segment AF, $u(t) = 0$ in the segment FG, and $u(t) = -1$ in the segment GO. Table 2 below contains the response time and the consumed fuel along each trajectory.

TABLE II (Refer to Fig. 7)

Trajectory	Consumed Fuel	Time
ABO	1.000	1.500
ADEO	1.000	1.625
AFGO	1.000	2.250

From the above table it is evident that all three trajectories require the

same amount of fuel but different response time. The trajectory ABO is the one which requires the least amount of time. This phenomenon is to be expected as pointed out in Section 1.7. Hence, the control law of Table 1 will result in a minimum-fuel trajectory which takes the least time to reach the origin.

3.6 The Design of the Controller

In this section we shall present the elements of design of a controller which will force any initial state to the origin with a minimum amount of fuel. The design is carried out using the results of Section 3.4.

A possible physical realization of the controller is shown in Fig. 8. In this figure the output x_1 of the plant $G(s)$ is differentiated in order to obtain $x_2 = \dot{x}_1$. The signal x_2 passes through a square-law nonlinearity, which may be realized by a biased diode network, and then through an attenuator to produce the signal $-\frac{1}{2} x_2 |x_2|$. The signal x_1 and $\frac{1}{2} x_2 |x_2|$ are added to produce the signal z . If the signal z is positive, then the state point is in Region I of IV; if the signal z is negative, then the state point is in Region II or III (refer to Fig. 5). We pass the signals z and x_2 through identical relays and add their outputs and then change the sign to obtain the signal w . The signal w is

$$w = \begin{cases} -2 & \text{if } (x_1, x_2) \text{ is in Region I} \\ 0 & \text{if } (x_1, x_2) \text{ is in Region II or IV} \\ +2 & \text{if } (x_1, x_2) \text{ is in Region III} \end{cases} \quad 3-44$$

The signal w is the input to a relay with a dead zone, as shown in Fig. 8, whose output drives the plant.

This suggested design requires a differentiating network, a square-law-type nonlinearity (which may be a biased diode network) two summing amplifiers, one inverter, two ideal relays, and one relay with dead zone. It is slightly more complicated than the controller required for the bang-bang control of the same plant.

3.7 Arbitrary Terminal States

In the previous Sections we have examined the minimum-fuel control of the plant $G(s) = 1/s^2$ when the terminal point was at the origin of the phase plane. In this Section we shall examine the control policy when the terminal point is not the origin. Note that due to the double integrating action of the plant $G(s)$, the plant is completely controllable; i. e., given any initial condition and any terminal state, one may reach that terminal state with controls $|u(t)| \leq 1$.

Suppose that the terminal point is $T = (1, 1)$, as shown in Fig. 9. We define three curves γ_0, γ_+ , and γ_- as follows:

- γ_0 is the locus of all points in the plane from which one may reach T using $u(t) = 0$.
- γ_+ is the locus of all points in the plane from which one may reach T using $u(t) = +1$.
- γ_- is the locus of all points in the plane from which one may reach T using $u(t) = -1$.

The curves γ_0, γ_+ , and γ_- are shown in Fig. 9. These curves also define Regions I, II, III, and IV, as shown in Fig. 9. It is easy to show that for minimum-fuel control and the least time of response, the control policy given in Table 3 is the optimal one.

TABLE III (Refer to Fig. 9)

Initial Conditions in	Optimal Control Policy
γ_0	Apply $u(t) = 0$ to reach T.
γ_+	Apply $u(t) = +1$ to reach T.
γ_-	Apply $u(t) = -1$ to reach T.
Region I	(1) Apply $u(t) = -1$ to just reach Region IV. (2) Apply $u(t) = 0$ to reach γ_+ curve. (3) Apply $u(t) = +1$ to reach T.
Region II	(1) Apply $u(t) = 0$ to reach γ_- curve. (2) Apply $u(t) = -1$ to reach T.
Region III	(1) Apply $u(t) = +1$ to reach γ_0 curve. (2) Apply $u(t) = 0$ to reach T.
Region IV	(1) Apply $u(t) = 0$ to reach γ_- curve. (2) Apply $u(t) = +1$ to reach T.

A controller, of analog nature, is shown in Fig. 9A. The controller was designed using the information of Table 3 and of Fig. 9. The signal x_2 passes through a nonlinearity which duplicates the γ_+ and γ_- of Fig. 9. The output signal of the nonlinearity is compared to the measured value of x_1 to yield the signal z . If z is positive, then the state point is to the right of the γ_- and γ_+ curves. If z is negative, the state point is to the left of the γ_- and γ_+ curves. The signal v indicates the polarity of the x_2 signal. The x_2 signal is compared with x_{2f} and w is the sign of the difference. But,

- (a) If $z > 0$ and $v = +1$, the state is in Region I.
- (b) If $z > 0$ and $v = -1$, the state is in Region IV.
- (c) If $z < 0$ and $w = +1$, the state is in Region II.
- (d) If $z < 0$ and $w = -1$, the state is in Region III.

The remaining relays, multipliers, and summers make a logical network which guarantees that the control law of Table 3 is used.

3.8 Summary and Conclusions.

In this Section we have examined the optimal control of a plant with the transfer function $G(s) = 1/s^2$. We have used the available information furnished by the adjoint system in order to establish an optimal minimum-fuel control policy for any set of initial conditions. The method of analysis was primarily geometrical in nature and it was necessary to use the shape of the trajectories in the phase plane resulting from the allowable values of the control function in order to design the controller, which can be of analog or digital nature. Thus, any set of initial conditions

can be forced to zero using a minimum amount of fuel. Furthermore, among the control policies leading to minimum fuel response, the controller automatically selects the one which require the least amount of response time.

The physical computer suggested is only slightly more complicated than the one for minimum time control of the same plant.

4. MINIMUM-FUEL CONTROL OF THE PLANT $G(s) = \frac{1}{(s+1)(s+2)}$

4.1 Introduction.

In this Section we examine the minimum-fuel control of a second-order plant described by the transfer function

$$G(s) = \frac{1}{(s+1)(s+2)} \quad \text{4-1}$$

This plant is not conservative, as the one described in Section 3, but it continually dissipates energy. The optimal control of this plant will be derived again through the use of the phase plane.

4.2 The Equations of Motion.

We are given the plant described by the transfer function of Eq. 4-1. Let $y_1(t)$ be the output of the plant and $u(t)$ be the input (control signal) to the plant. We assume that

$$|u(t)| \leq 1. \quad \text{4-2}$$

The output $y_1(t)$ is the solution of the differential equation

$$(D+1)(D+2)y_1(t) = (D^2+3D+2)y_1(t) = u(t) \quad \text{4-3}$$

where $D \triangleq d/dt$ is the differential operator. We define the variables

$$\begin{aligned} y_1(t) &= y_1(t) \\ y_2(t) &= \dot{y}_1(t) \end{aligned} \quad \text{4-4}$$

¶ The numbers 1 and 2 in the transfer function were chosen for computational facility. Many algebraic equations turn out to be quadratic, and roots may be determined easily without the use of digital computers. Although the ideas presented will be true for arbitrary values for the poles, the actual computation of various curves will be more difficult.

which satisfy the matrix differential equation

$$\begin{bmatrix} \dot{y}_1 \\ \dot{y}_2 \end{bmatrix} = \begin{bmatrix} 0 & 1 \\ -2 & -3 \end{bmatrix} \begin{bmatrix} y_1 \\ y_2 \end{bmatrix} + \begin{bmatrix} 0 \\ u(t) \end{bmatrix} \quad 4-5$$

which is of the form $\dot{\underline{y}} = \underline{A}\underline{y} + \underline{B}u$.

Let $\underline{\Lambda}$ be the diagonal matrix

$$\underline{\Lambda} = \begin{bmatrix} -1 & 0 \\ 0 & -2 \end{bmatrix} \quad 4-6$$

Then there exists a nonsingular matrix \underline{P}

$$\underline{P} = \begin{bmatrix} 1 & 1 \\ -1 & -2 \end{bmatrix} \quad 4-7$$

with the inverse \underline{P}^{-1}

$$\underline{P}^{-1} = \begin{bmatrix} 2 & 1 \\ -1 & -1 \end{bmatrix} \quad 4-8$$

such that

$$\underline{\Lambda} = \underline{P}^{-1} \underline{A} \underline{P} \quad 4-9$$

Define the state variables x_1, x_2 by

$$\underline{x} = \underline{P}^{-1} \underline{y} \quad 4-10$$

which implies

$$\left. \begin{aligned} x_1 &= 2y_1 + y_2 \\ x_2 &= -y_1 - y_2 \end{aligned} \right\} \quad 4-11$$

Then, the \underline{x} -variables satisfy the differential equation

$$\begin{bmatrix} \dot{x}_1 \\ \dot{x}_2 \end{bmatrix} = \begin{bmatrix} -1 & 0 \\ 0 & -2 \end{bmatrix} \begin{bmatrix} x_1 \\ x_2 \end{bmatrix} + \begin{bmatrix} 2 & 1 \\ -1 & -1 \end{bmatrix} \begin{bmatrix} 0 \\ u(t) \end{bmatrix} \quad 4-12$$

or

$$\left. \begin{aligned} \dot{x}_1 &= -x_1 + u(t) & ; & & x_1(0) \triangleq \xi_1 \\ \dot{x}_2 &= -2x_2 - u(t) & ; & & x_2(0) \triangleq \xi_2 \end{aligned} \right\} \quad 4-13$$

It is desired to determine the optimal control $u(t)$ which will force the system described by Eq. 4-12 from an initial state (ξ_1, ξ_2) to a terminal state $T = (x_{1f}, x_{2f})$ such that the fuel

$$F = \int_0^t |u(t)| dt \quad 4-14$$

is minimum.

The Hamiltonian H is given by

$$H = |u(t)| + \langle \underline{\Lambda}, \underline{x}, \underline{p} \rangle + \left\langle \begin{bmatrix} u(t) \\ -u(t) \end{bmatrix}, \begin{bmatrix} p_1 \\ p_2 \end{bmatrix} \right\rangle \quad 4-15$$

where the costate \underline{p} is the solution of the adjoint system

$$\dot{\underline{p}} = - \underline{\Lambda} \underline{p} = - \underline{\Lambda} \underline{p} \quad ; \quad \underline{p}(0) = \underline{\eta} \quad 4-16$$

which implies

$$\begin{aligned} p_1(t) &= \eta_1 e^t \\ p_2(t) &= \eta_2 e^{2t} \end{aligned} \quad 4-17$$

The optimal control law is

$$\begin{aligned} u(t) &= 0 & \text{if} & \quad | \eta_1 e^t - \eta_2 e^{2t} | < 1 \\ u(t) &= -\text{sgn} \left\{ \eta_1 e^t - \eta_2 e^{2t} \right\} & \text{if} & \quad | \eta_1 e^t - \eta_2 e^{2t} | \geq 1 \end{aligned} \quad 4-18$$

Therefore, for minimum-fuel control

$$\begin{aligned} u(t) &= 0 & \text{or} & \\ u(t) &= \Delta = \begin{matrix} + \\ - \end{matrix} 1 \end{aligned} \quad 4-19$$

Substituting Eq. 4-19 in Eq. 4-13, we find:

Case 1: If $u(t) = 0$, then

$$\begin{aligned} x_1(t) &= \xi_1 e^{-t} \\ x_2(t) &= \xi_2 e^{-2t} \end{aligned} \quad 4-20$$

Case 2: If $u(t) = \Delta = \pm 1$, then

$$\left. \begin{aligned} x_1(t) &= (\xi_1 - \Delta)e^{-t} + \Delta \\ x_2(t) &= (\xi_2 + 0.5\Delta)e^{-2t} - 0.5\Delta \end{aligned} \right\} \quad 4-21$$

Eliminating the time t from Eq. 4-20, we obtain the equations of the free trajectories

$$x_2 = \frac{\xi_2}{\xi_1} x_1^2 \quad 4-22$$

These trajectories are shown in Fig. 10. The arrows indicate motion of the state points for positive time.

Eliminating the time t from Eq. 4-21, we obtain the equations of the forced trajectories

$$x_2 = -0.5\Delta + (\xi_2 + 0.5\Delta) \left[\frac{x_1 - \Delta}{\xi_1 - \Delta} \right]^2 \quad 4-23$$

The forced trajectories are shown in Fig. 11 for $\Delta = +1$ and in Fig. 12 for $\Delta = -1$.

4.3 Information From the Adjoint System.

The control law of Eq. 4-18 indicates that the value of the control depends on the function

$$q(t) \triangleq \eta_1 e^t - \eta_2 e^{2t} \quad 4-24$$

Examination of the possible forms of $q(t)$, for all values of η_1, η_2 and time, leads to

the following allowable forms of the control $u(t)$:

$$u(t) = 0 \qquad 0 \leq t \leq t_f \qquad 4-25$$

$$u(t) = +1 \qquad 0 \leq t \leq t_f \qquad 4-26$$

$$u(t) = -1 \qquad 0 \leq t \leq t_f \qquad 4-27$$

$$u(t) = \begin{cases} 0 & 0 \leq t < t_1 \\ +1 & t_1 \leq t \leq t_f \end{cases} \qquad 4-28$$

$$u(t) = \begin{cases} 0 & 0 \leq t < t_1 \\ -1 & 0 \leq t \leq t_f \end{cases} \qquad 4-29$$

$$u(t) = \begin{cases} +1 & 0 \leq t < t_1 \\ 0 & t_1 \leq t \leq t_f \end{cases} \qquad 4-30$$

$$u(t) = \begin{cases} -1 & 0 \leq t < t_1 \\ 0 & t_1 \leq t \leq t_f \end{cases} \qquad 4-31$$

$$u(t) = \begin{cases} +1 & 0 \leq t < t_1 \\ 0 & t_1 \leq t < t_2 \\ -1 & t_2 \leq t \leq t_f \end{cases} \qquad 4-32$$

$$u(t) = \begin{cases} -1 & 0 \leq t < t_1 \\ 0 & t_1 \leq t < t_2 \\ +1 & t_2 \leq t \leq t_f \end{cases} \qquad 4-33$$

$$u(t) = \begin{cases} +1 & 0 \leq t < t_1 \\ 0 & t_1 \leq t < t_2 \\ +1 & t_2 \leq t \leq t_f \end{cases} \quad 4-34$$

$$u(t) = \begin{cases} -1 & 0 \leq t < t_1 \\ 0 & t_1 \leq t < t_2 \\ -1 & t_2 \leq t \leq t_f \end{cases} \quad 4-35$$

$$u(t) = \begin{cases} 0 & 0 \leq t < t_1 \\ +1 & t_1 \leq t < t_2 \\ 0 & t_2 \leq t < t_3 \\ -1 & t_3 \leq t \leq t_f \end{cases} \quad 4-36$$

$$u(t) = \begin{cases} 0 & 0 \leq t < t_1 \\ -1 & t_1 \leq t < t_2 \\ 0 & t_2 \leq t < t_3 \\ +1 & t_3 \leq t \leq t_f \end{cases} \quad 4-37$$

4.4 The Origin as the Terminal Point.

The problem for which the origin is the terminal point is trivial since $u(t) = 0$ must be applied, as explained in Section 2.5.

4.5 Terminal Point $T = (0.4, -0.2)$.

In this section we consider the problem of forcing the plant from an arbitrary initial state (ξ_1, ξ_2) to the terminal state $T = (0.4, -0.2)$. We will analyze the system for that specific terminal point in order to present in the clearest way the concepts which will be required. Otherwise, the symbols and terminology might overshadow the essential concepts and ideas and lead to confusion.

Define three curves called the γ_0 , γ_+ , and γ_- curves as follows:

γ_0 is the locus of all points in the $x_1 - x_2$ phase plane which, using $u(t) = 0$, are forced to the terminal point $T = (0.4, -0.2)$. The equation of the γ_0 curve is

$$x_2 = -0.2 \left[\frac{x_1}{0.4} \right]^2 = -1.25 x_1^2 \quad 4-38$$

and is defined in the region

$$x_1 \geq 0.4 \quad ; \quad x_2 \leq -0.2 \quad . \quad 4-39$$

γ_+ is the locus of all points in the $x_1 - x_2$ plane which, using $u(t) = -1$, are forced to the terminal point $T = (0.4, -0.2)$. The equation of the γ_+ curve is, from Eq. (4-23),

$$x_2 = 0.5 - 0.834 (x_1 - 1)^2 \quad 4-40$$

in the region defined by

$$x_1 \leq 0.4 \quad ; \quad x_2 \geq -0.2 \quad 4-41$$

γ_- is the locus of all points in the $x_1 - x_2$ plane which, using $u(t) = -1$, are forced to the terminal point $T = (0.4, -0.2)$.
The equation of the γ_- curve is, from Eq. 4-23,

$$x_2 = 0.5 - 0.357(x_1 + 1)^2 \quad 4-42$$

in the region defined by

$$x_1 \geq 0.4 \quad ; \quad x_2 \leq -0.2 \quad 4.43^{\varphi}$$

The curves γ_0, γ_+ , and γ_- are shown in Fig. 13.

It is clear that the curve γ_0 is optimal. Hence, if $(\xi_1, \xi_2) \in \gamma_0$, then $u(t) = 0$ is the minimum fuel optimal control policy.

Now we will determine the fuel required to force the plant from an initial state at the origin, i.e., at $(0, 0)$, to the point $T = (0.4, -0.2)$. The control policy of Eq. 4-30 must be followed. Hence, if the initial state is at the origin, then we must apply $u(t) = +1$ until the curve γ_0 is reached and then switch to $u(t) = 0$. It is easy to compute that the fuel required is

$$F_m = 0.84 \text{ units}^{\varphi\varphi} \quad 4-53$$

But we know that any initial state in the $x_1 - x_2$ plane may be taken to the origin with zero fuel. Hence, we may draw the following conclusion:

In order to reach the terminal state $T = (0.4, -0.2)$ from any initial state, the maximum fuel required is 0.84 units.

φ Through error in numbering, Eq. 4-43 is followed by Eq. 4-53.

$\varphi\varphi$ All numerical results are within slide rule accuracy.

Consider all initial states $(\hat{\xi}_1, \hat{\xi}_2)$ which may be forced to the γ_0 curve using $u(t) = +1$. Since along the trajectories the time elapsed is equal to the fuel consumed, the equation of the above trajectories is, from Eq. 4-21,

$$\begin{aligned} x_1 &= 1 + (\hat{\xi}_1 - 1)e^{-F} \\ x_2 &= -0.5 + (\hat{\xi}_2 + 0.5)e^{-2F} \end{aligned} \quad 4-54$$

But the γ_0 curve has the equation

$$x_2 = -1.25 x_1^2 \quad 4-54a$$

Therefore, for intersection of the trajectories defined by Eq. 4-54a with the γ_0 curve

$$-0.5 + (\hat{\xi}_2 + 0.5)e^{-2F} = -1.25 \left[1 + (\hat{\xi}_1 - 1)e^{-F} \right]^2 \quad 4-55$$

or

$$\hat{\xi}_2 = -0.5 + 0.5 e^{2F} - 1.25 \left[e^F + \hat{\xi}_1 - 1 \right]^2 \quad 4-56$$

Equation 4-56 defines a family of curves in the phase plane with F as a parameter. We shall call these curves equal-fuel curves, since any initial state satisfying Eq. 4-56 may be taken to T , using the control policy of Eq. 4-30, with the same amount of fuel F . In Fig. 14 we show some equal-fuel lines for the values $F = 0$, $F = 0.2$, $F = 0.5$, $F = 0.84$, and $F = 1.0$. Note that the $F = 0$ curve is the γ_0 curve and that all equal fuel curves terminate on the γ_+ curve. The $F = 0.84$ curve passes

through the origin.

Now consider any free trajectory

$$x_2 = \beta x_1^2 \quad 4-57$$

Each of the free trajectories will intersect many equal fuel lines. Denote the points of intersection by (\hat{x}_1, \hat{x}_2) . Then,

$$\beta \hat{x}_1^2 = -0.5 + 0.5e^{2F} - 1.25 \left[e^F + \hat{x}_1 - 1 \right]^2 \quad 4-58$$

Equation 4-58 is quadratic in \hat{x}_1 ; hence,

$$\hat{x}_1 = \frac{1}{2a} \left[b \pm \sqrt{b^2 - 4ac} \right] \quad 4-59$$

where

$$a = \beta + 1.25 \quad 4-60$$

$$b = 2.50 (1 - e^F) \quad 4-61$$

$$c = 0.75 e^{2F} - 2.50 e^F + 1.75 \quad 4-62$$

If

$$b^2 - 4ac = 0, \quad 4-63$$

then the free trajectory will be tangent to an equal-fuel line. Equation 4-63 implies

$$(2.50 - 3\beta)e^{2F} + 10\beta e^F - 2.50 - 7\beta = 0 \quad 4-64$$

which is quadratic in e^F , with the two solutions

and

$$e^F = 1 \quad 4-65$$

$$e^F = - \frac{2.50 + 7\beta}{2.50 - 3\beta} \quad 4-66$$

The point of tangency (\hat{x}_1, \hat{x}_2) is given by

$$\left. \begin{aligned} \hat{x}_1 &= \frac{2.50(1 - e^F)}{2(\beta + 1.25)} \\ \hat{x}_2 &= \beta \hat{x}_1^2 \end{aligned} \right\} \quad 4-67$$

where e^F is given by Eq. 4-66. The solution $e^F = 1$ in Eq. 4-65 implies $F = 0$, and it represents the tangency point at the origin between any free trajectory and the extension of the γ_0 curve; hence it is discarded.

Substituting Eq. 4-66 into 4-67, we find

$$\left. \begin{aligned} \hat{x}_1 &= \frac{5}{2.50 - 3\beta} \\ \hat{x}_2 &= \beta \hat{x}_1^2 \end{aligned} \right\} \quad 4-68$$

We plot the curve defined by Eq. 4-68 in Fig. 15, and we denote it as the γ_2 curve.

It is plotted for β in the range

$$-\infty < \beta < -1.25 \quad 4-69$$

To recapitulate:

- (1) We have found the locus of all points $(\hat{\xi}, \hat{\xi}_2)$ which may be forced to the γ_0 curve with $u(t) = +1$ and which require the same fuel F

order to reach the terminal point $T = (0.4, -0.2)$. Equation 4-56 is the equation of these curves.

(2) We have determined the equal-fuel curve which is tangent to a given free trajectory. This tangent equal-fuel line is described by F obtained from Eq. 4-66, and the point of tangency (\hat{x}_1, \hat{x}_2) is given by Eq. (4-68). The locus of all (\hat{x}_1, \hat{x}_2) points is the γ_2 curve in Fig. 15.

The next step in the analysis is to find whether the curve γ_+ is optimal. We will have to use all the facts assembled up to now in order to be able to make this decision.

Suppose that the initial state (ξ_1, ξ_2) is on the γ_+ curve, described by Eqs. 4-40 and 4-41. We know that the control policy $u(t) = +1$ will force the state (ξ_1, ξ_2) to T . In Fig. 14 the point $Q = (-0.4, 1.15)$ is the intersection of the $F = 0.84$ equal-fuel curve and the γ_+ curve. From the point Q there are two ways of reaching T using the same amount of fuel equal to 0.84 units. One way is to apply $u(t) = +1$ until T is reached. The other way is to apply $u(t) = 0$ until we reach the origin, then apply $u(t) = +1$ until we reach the curve γ_0 , and then apply $u(t) = 0$ to reach T . The former policy requires the least time.

Now suppose that $(\xi_1, \xi_2) \in \gamma_+$ in the region defined by

$$-0.4 < x_1 < +0.4 \quad . \quad 4-70$$

At (ξ_1, ξ_2) terminates an equal-fuel line. Let the fuel required be denoted by F . If the control $u(t) = 0$, instead of $u(t) = +1$, is applied at (ξ_1, ξ_2) then the resulting free

trajectory will intersect equal-fuel lines with parameter F such that

$$F > \hat{F} \quad 4-71$$

as is apparent from Figs. 10 and 14. The same thing happens if $u(t) = -1$ is applied.

Thus, we may draw the conclusion:

$$\begin{aligned} \underline{\text{If}} (\xi_1, \xi_2) \in \gamma_+ \text{ in the region} \\ x_1 < -0.4, \end{aligned} \quad 4-72$$

if $u(t) = +1$ is applied, then the fuel required will be greater than 0.84 units. Hence, $u(t) = +1$ is not the optimal control, since we can always reach T with a maximum amount of fuel equal to 0.84 units.

Consider all points in the plane such that they may be taken to the curve γ_0 using $u(t) = -1$. We shall denote these points by $(\tilde{\xi}_1, \tilde{\xi}_2)$. Their equation is

$$\begin{aligned} x_1 &= (\tilde{\xi}_1 + 1)e^{-F} - 1 \\ x_2 &= (\tilde{\xi}_2 - 0.5)e^{-2F} + 0.5 \end{aligned} \quad 4-73$$

Since the γ_0 curve has the equation

$$x_2 = -1.25 x_1^2, \quad 4-74$$

it follows that

$$(\tilde{\xi}_2 - 0.5)e^{-2F} + 0.5 = -1.25 \left[(\tilde{\xi}_1 + 1)e^{-F} - 1 \right]^2 \quad 4-75$$

or

$$\tilde{\xi}_2 = 0.5 - 0.5e^{2F} - 1.25 \left[\tilde{\xi}_1 + 1 - e^F \right]^2 \quad 4-76$$

Equation 4-76 is the equation of another family of equal-fuel curves. They are plotted in Fig. 16. They terminate on the γ_- curve. The reason that the line $F = 0.262$ is included is as follows: Consider the intersection of the γ_+ curve with the x_1 axis. The point of intersection is at (0.22, 0). The fuel required to go along the γ_+ curve to the terminal state T is 0.262 units.

Now consider points to the right of the γ_+ and γ_- curves and in the fourth quadrant of the x_1 - x_2 plane. It is easy to see that the optimal control policy is to apply $u(t) = 0$ until the γ_+ curve is reached and then to apply $u(t) = +1$. The intersection of the free trajectory with the γ_+ curve will occur in the region

$$\left. \begin{array}{l} 0.22 < x_1 < 0.4 \\ 0 < x_2 < -0.2 \end{array} \right\} \quad 4-77$$

and the maximum fuel required is

$$F_m^* = 0.262 \text{ units.} \quad 4-78$$

Now consider points in the region between the γ_0 and γ_- curves. There are three ways of forcing them to T.

- (1) Apply $u(t) = -1$ until γ_0 is reached and then apply $u(t) = 0$.
- (2) Apply $u(t) = 0$ until γ_- is reached and then apply $u(t) = -1$.
- (3) Apply $u(t) = 0$ until γ_+ is reached and then apply $u(t) = 1$.

Now we shall show that policy (2) above is not optimal with respect to (1). Suppose that (ξ_1, ξ_2) is on the equal-fuel curve with $F = F_1$. Equation 4-76 is the equation of a parabola with vertex at the point $(e^{F_1} - 1, 0.5 - 0.5e^{2F_1})$, which is a point in the fourth

quadrant of the x_1 - x_2 plane. It follows that a free trajectory will intersect the γ_- curve at a point for which $F = F_2$ such that

$$F_2 > F_1 \quad 4-79$$

Now we shall compare policies (1) and (3) above. Given a point $(\tilde{\xi}_1, \tilde{\xi}_2)$ in the region between γ_0 and γ_- curves, if $u(t) = -1$ is applied until the γ_0 curve is reached, then the fuel required is found to be, from Eq. 4-76

$$e^F = \frac{1}{3.50} \left[2.50(\tilde{\xi}_2 + 1) - \sqrt{1 - 7\tilde{\xi}_2 - 2.50\tilde{\xi}_1^2 - 5\tilde{\xi}_1} \right] \quad 4-80$$

Now suppose that at $(\tilde{\xi}_1, \tilde{\xi}_2)$ we apply $u(t) = 0$ until the γ_+ curve is reached, in the region defined by Eq. 4-77, and then $u(t) = +1$ is applied to reach T. Let the fuel required be denoted by F' . The free trajectory has the equation

$$x_2 = \frac{\tilde{\xi}_2}{\tilde{\xi}_1^2} x_1^2 \quad 4-81$$

The γ_+ curve is defined by

$$\left. \begin{aligned} x_1 &= \frac{1}{2} - 0.6e^{F'} \\ x_2 &= -0.5 + 0.3e^{2F'} \end{aligned} \right\} \quad 4-82$$

Hence,

$$-0.5 + 0.3e^{2F'} = \frac{\tilde{\xi}_2}{\tilde{\xi}_1^2} \left[\frac{1}{2} - 0.6e^{F'} \right]^2 \quad 4-83$$

which may be solved for $e^{F'}$ to yield

$$e^{F'} = \frac{1}{0.6 \left[\tilde{\xi}_1^2 - 1.2 \tilde{\xi}_2 \right]} \left[-1.2 \tilde{\xi}_2 + \tilde{\xi}_1 \sqrt{0.6 \left[\tilde{\xi}_1^2 + 0.8 \tilde{\xi}_2 \right]} \right] \quad 4-84$$

The locus of all points $(\tilde{\xi}_1, \tilde{\xi}_2)$ such that

$$e^F = e^{F'} \quad 4-85$$

have the property that either policy (1) or policy (3) will require the same amount of fuel. This locus is denoted as the γ_3 curve and is shown in Fig. 17. Note that γ_3 terminates at the terminal point $T = (0.4, -0.2)$. We may draw the following conclusions:

If the initial state is between the γ_0 and γ_3 curves, then the optimal control policy is to apply $u(t) = -1$ until the curve γ_0 is reached and then to apply $u(t) = 0$.

If the initial state is to the right of the γ_3 curve, the optimal control policy is to apply $u(t) = 0$ until the curve γ_+ is reached and then to apply $u(t) = +1$.

Since the γ_- curve is to the right of the γ_3 curve, it follows that the curve γ_- is not optimal.

In Fig. 18 we show the division of the phase plane into regions of operation for optimal control. As a partial summary we identify the various curves shown and their equations.

γ_+ : The defining equation of the γ_+ curve is

$$x_2 = -0.5 + 0.834(x_1 - 1)^2 \quad 4-86$$

in the region

$$\left. \begin{array}{l} -0.4 < x_1 < +0.4 \\ -0.2 < x_2 < +1.15 \end{array} \right\} \quad 4-87$$

γ_0 : The defining equation of γ_0 is

$$x_2 = -1.25 x_1^2 \quad 4-88$$

in the region

$$x_1 \geq 0.4 \quad ; \quad x_2 < -0.2 \quad 4-89$$

γ_1 : The curve γ_1 is a portion of the $F = 0.84$ equal-fuel curve. Its equation is, letting $F = 0.84$ in Eq. 4-56

$$x_2 = 2.3 - 1.25 \left[1.365 + x_1 \right]^2 \quad 4-90$$

in the region

$$\left. \begin{array}{l} -0.4 < x_1 < 0 \\ 0 < x_2 < 1.15 \end{array} \right\} \quad 4-91$$

γ_2 : The curve γ_2 in the locus of the tangency points of free trajectories with equal-fuel curves. Its equation is, from Eq. 4-68,

$$x_2 = \frac{1}{3} \left[2.50 x_1^2 - 5 x_1 \right] \quad 4-92$$

in the region

$$\left. \begin{array}{l} 0 < x_1 < 0.8 \\ -0.8 < x_2 < 0 \end{array} \right\} \quad 4-93$$

γ_3 : The curve γ_3 is obtained from Eqs. 4-80, 4-84, and 4-85, and is valid in the region

$$0.4 < x_1 \quad ; \quad x_2 > -0.2 \quad . \quad 4-94$$

In Fig. 18 we also define three regions of operation. Region I is the slice between the γ_0 and γ_3 curves, including the γ_3 curve but not the γ_0 curve. Region II is the set of points enclosed by the γ_+ , γ_1 , γ_2 , and γ_0 curves. The curves γ_1 and γ_2 are parts of Region II, but not the curves γ_0 and γ_+ . Region III is the rest of the space.

We shall now present the optimal control law using the region in Fig. 18. The optimal control is given in Table 4.

TABLE IV (Refer to Fig. 18)

Initial State in	Control Policy
γ_+	Apply $u(t) = +1$ to reach T.
γ_0	Apply $u(t) = 0$ to reach T.
Region I	1) Apply $u(t) = -1$ to reach γ_0 curve. 2) Apply $u(t) = 0$ to reach T.
Region II	1) Apply $u(t) = +1$ to reach γ_0 curve. 2) Apply $u(t) = 0$ to reach T.
Region III	1) Apply $u(t) = 0$ to reach Region II or γ_+ curve. 2) Apply $u(t) = +1$ to reach γ_0 or T. 3) If γ_0 is reached, apply $u(t) = 0$ to reach T.

We have already discussed how the optimal policy in Region I was derived. Let us now explain the control policy in Region II.

Consider any state (ξ_1, ξ_2) in Region II. From Fig. 14 it is evident that the point (ξ_1, ξ_2) will be on an equal-fuel curve with $0 \leq \hat{F} \leq 0.84$. Initial application of $u(t) = 0$ or $u(t) = -1$ will result in a trajectory which will intersect equal-fuel curves with $F > \hat{F}$. A little thought will convince the reader that $u(t) = +1$ is the optimum control.

Now we will examine states in Region III. Consider the points in the first quadrant and in Region III. The application of $u(t) = 0$ will force them to the γ_+ curve. Any other policy will require more fuel. Consider the points in the second quadrant and in Region III. If the initial state is to the right of a free trajectory terminating at the point Q, then $u(t) = 0$ will force the state point to the γ_+ curve. Otherwise, $u(t) = 0$ will force them to the origin. From the origin $u(t) = +1$ will force the state to γ_0' , etc. Points in the third quadrant will be forced to the origin by $u(t) = 0$. In the fourth quadrant initial states to the right of the γ_+ and γ_3 curves will be forced to γ_+ with $u(t) = 0$, as already explained. Now consider initial states in the fourth quadrant and Region III. At the curve γ_2 the free trajectory is tangent to an equal-fuel curve. From the shape of the equal-fuel curves in Fig. 14, it is evident that the control $u(t)$ must change from 0 to +1 on the curve γ_2 .

4.6 Summary and Conclusions.

We have discussed in detail the optimum control of a plant with the transfer function of Eq. 4-1. The major part of the Section 4 was devoted to the study of the minimum-fuel control for a terminal point not at the origin of the phase plane. It was necessary to introduce the concept of the equal-fuel curves in order to arrive at the optimal control policy. It was found that the phase plane was divided into three regions of

operation, and that for each region, an optimal control was specified in Table 4.

The whole problem was examined with the greatest detail possible in order to bring into focus the steps which must be followed in problems similar to the one treated.

5. CONCLUSIONS AND SUGGESTIONS FOR FUTURE RESEARCH

In this report we have shown that for minimum-fuel control of a linear time invariant plant, each component of the control vector should have the values +1, 0, or -1 if unity is the bound on the magnitude of the control vector components. Furthermore, we have shown that the magnitude and polarity of the control depends on the output of the adjoint system.

We have used the properties of the output of the adjoint system in order to analyze the optimal response of two second-order plants. The analysis was primarily geometrical and was carried out in the phase plane, using as a guide the system trajectories and the concept of the equal-fuel curves.

One of the second-order systems examined was a double integral plant. It was found that the analysis in the phase plane was quite easy and a complete controller was designed using the results. The other system examined was a second-order plant with two real and negative poles. It was found that the phase plane can be separated into three regions of operation and that in each region corresponds an optimal value for the control function.

5.2 The Unsolved Problems.

The first problem which must be solved, in the opinion of the author, is the general second-order system. The second-order system with arbitrary distinct real poles will give a lot of insight into the operation of high-order systems. Second-order systems with complex poles are very important and they should also be examined in detail. The experience and results obtained from the two examples in this report indicate that the concepts of equal-fuel lines and of the region of operation will be

helpful in the determination of the optimal feedback control function.

A natural follow-up is the design of higher-order systems. However, if high-order systems are expensive, and if the use of digital computers is economically justifiable, then a set of control equations could be obtained which may be solved by the digital computers.

In this report we have assumed that the response time was not fixed. There are many problems for which the response time is fixed, and one is interested in determining the control which will accomplish the required control task in the given fixed time with a minimum amount of fuel. For such problems the results given in this report can be used to advantage, but their extension is not trivial. The requirement that the response time is fixed would require different regions of operation, which will be defined by the equations of both equal-fuel curves and equal-time curves (isochrones). The control functions for these fixed-time, minimum-fuel systems will again have the values +1, 0, or -1. Similar problems to the above are systems for which the fuel is fixed and it is required to minimize the response time.

REFERENCES

1. R. E. Kalman, Y. C. Ho, and K. S. Narendra, "Controllability of Linear Dynamical Systems," to be published.
2. R. E. Kalman, "Canonical Structure of Linear Dynamical Systems," to be published.
3. R. E. Kalman "The Theory of Optimal Control and the Calculus of Variations," RIAS Technical Report 61-3, Baltimore, Md., 1961.
4. L. S. Pontriagin, "Optimum Control Processes," Automation Express, Vol. 1, No. 10, 1959, pp. 15-18, and Vol. 2, No. 1, 1959, pp. 26-30.
5. E. Boltianskii et al, "The Maximum Principle in the Theory of Optimal Processes of Control," Proc. First International Congress on Autom. Control, Moscow, 1960, pp. 454-459.
6. L. I. Rozonoer, "L. S. Pontriagin's Maximum Principle in the Theory of Optimum Systems," Automation and Remote Control, Vol. 20, Oct., Nov., Dec., 1959, pp. 1288-1302, pp. 1405-1421, pp. 1517-1532.
7. M. Athanassiades, "Bang-Bang Control of Real Pole Systems," Electronics Research Laboratory, Series No. 60, Issue No. 377, University of California, Berkeley, Calif., June 1961.

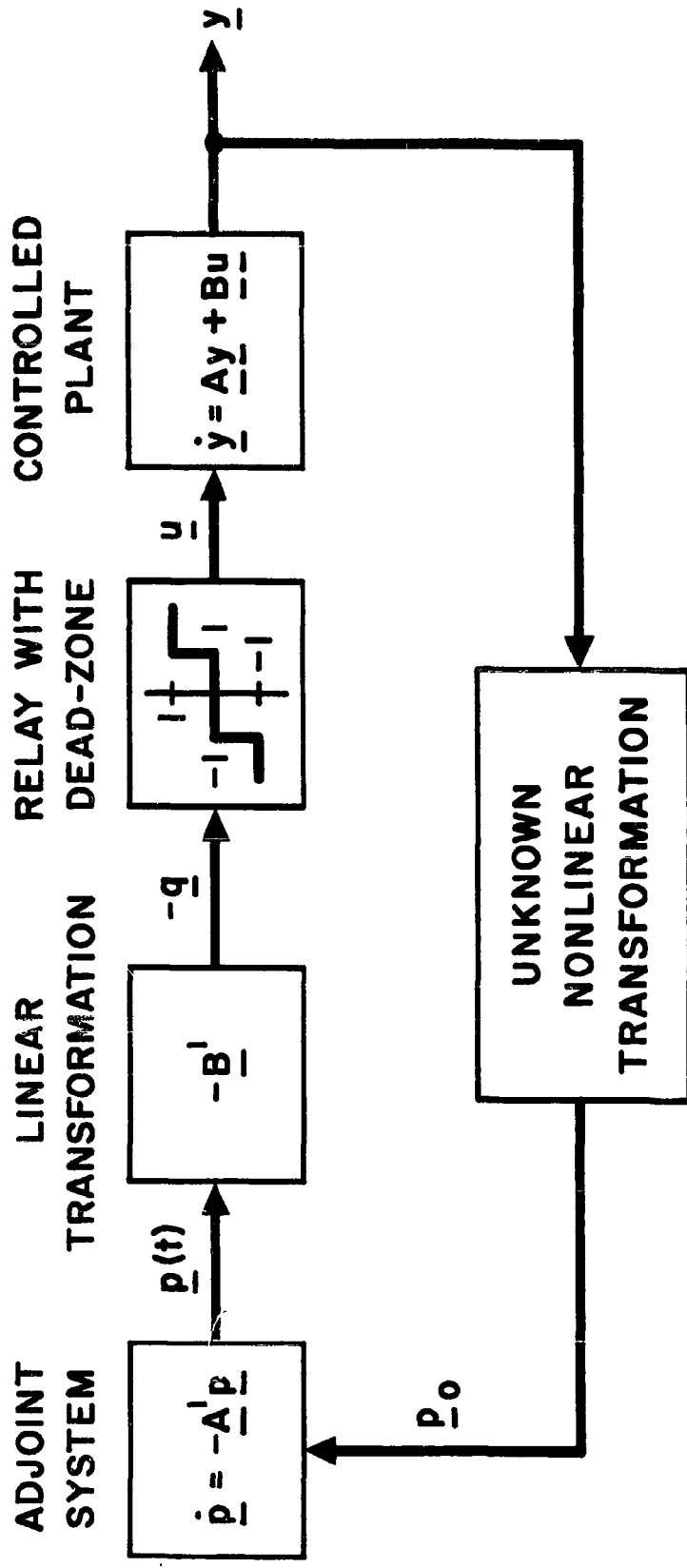

FIG. 1 CONCEPTUAL BLOCK DIAGRAM OF A MINIMUM FUEL SYSTEM USING THE ADJOINT SYSTEM.

3-22-3769

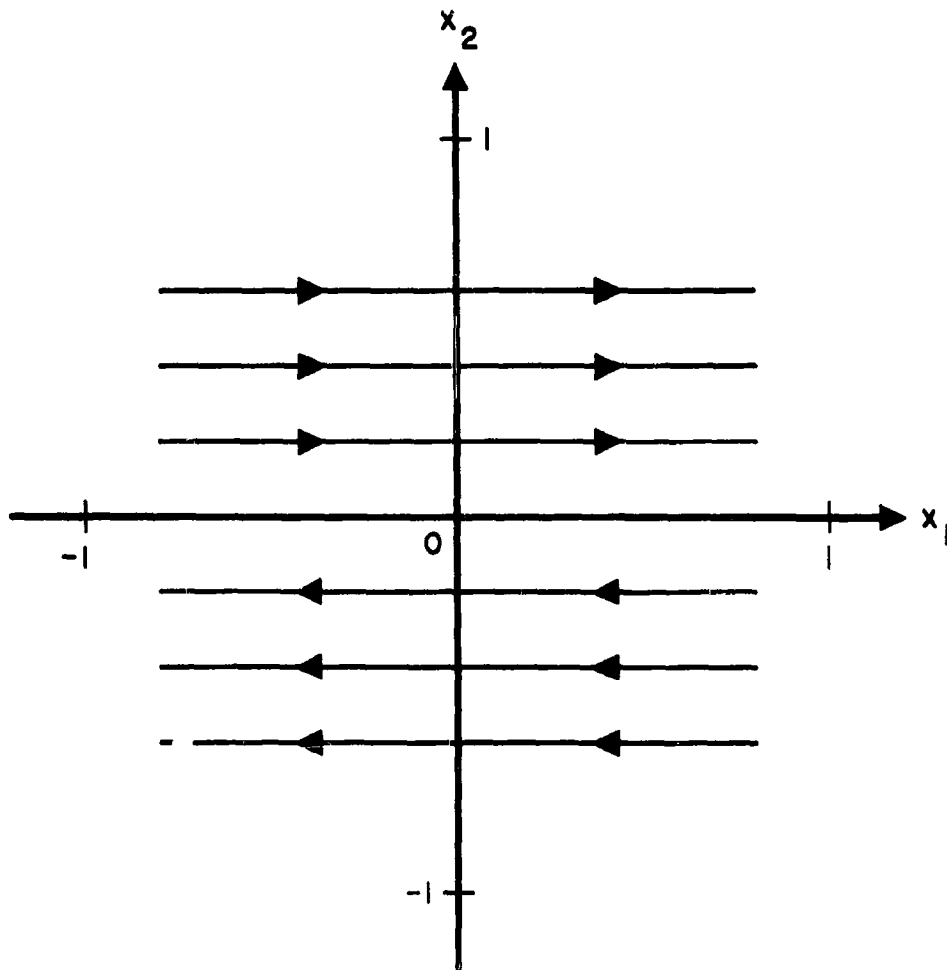

FIG. 2 PHASE PLANE TRAJECTORIES OF $1/s^2$ FOR $u(t) = 0$.

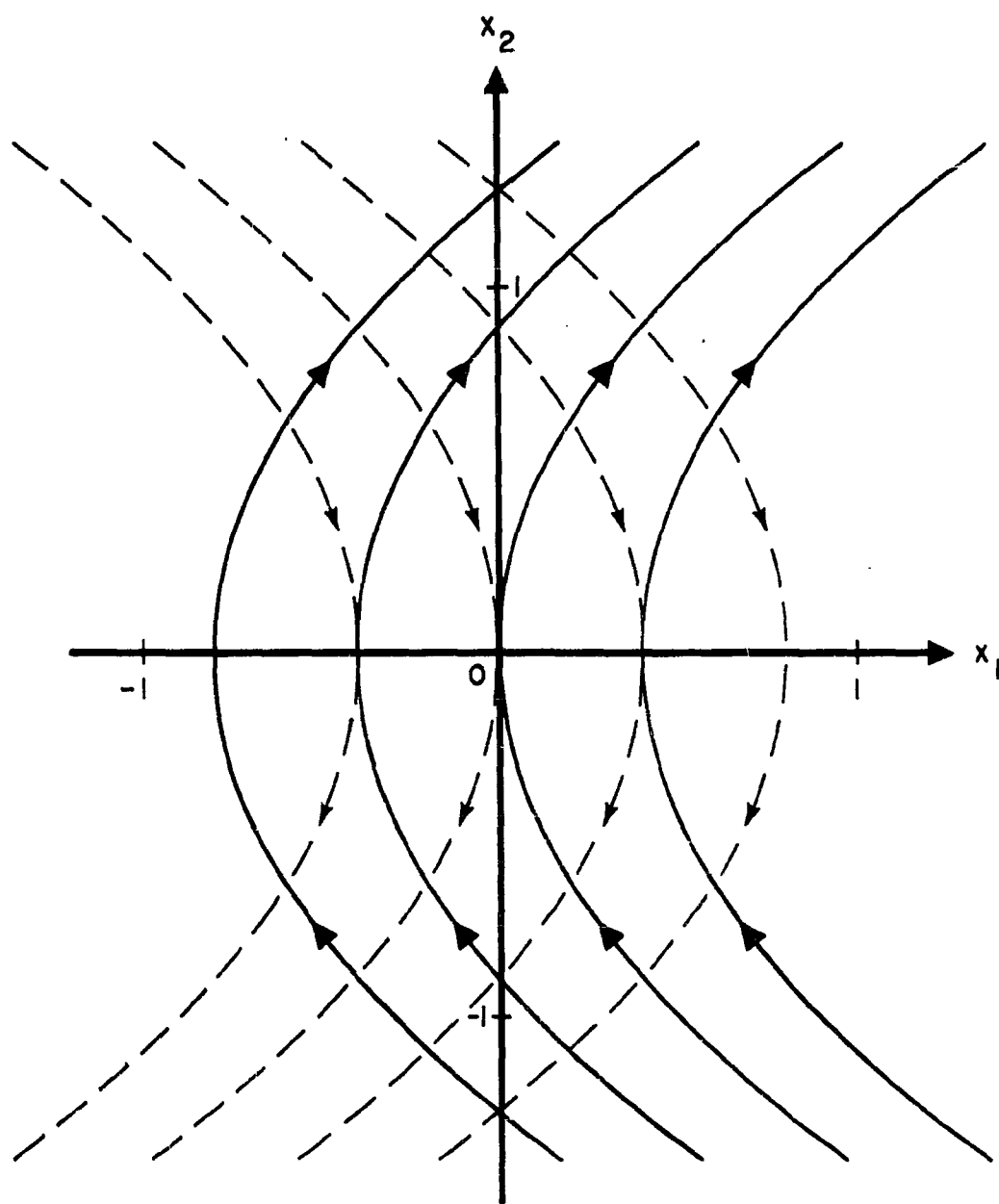
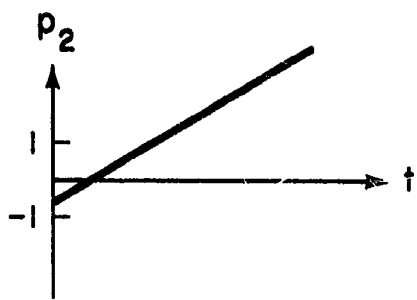
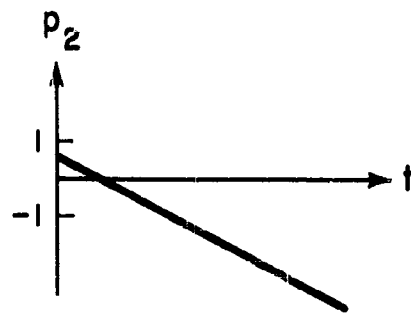

FIG. 3 PHASE PLANE TRAJECTORIES OF $1/s^2$ FOR $u(t) = +1$ (SOLID CURVES) AND FOR $u(t) = -1$ (DOTTED CURVES).



$\eta_1 < 0; -1 < \eta_2 < 1$
(a)



$\eta_1 > 0; -1 < \eta_2 < 1$
(b)

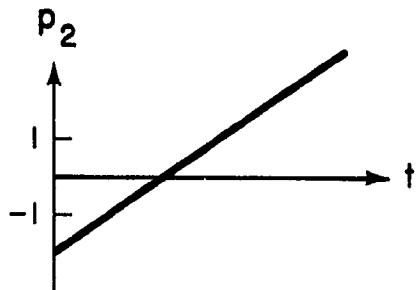

$\eta_1 < 0; \eta_2 < -1$
(c)

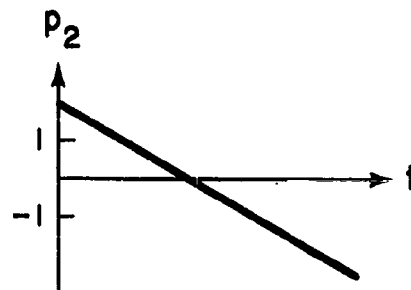

$\eta_1 > 0; \eta_2 > -1$
(d)

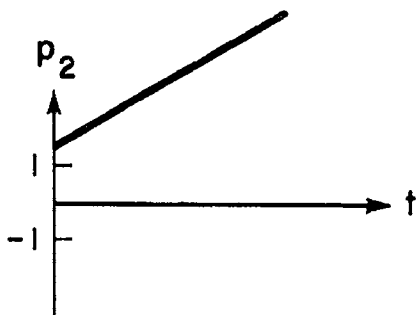

$\eta_1 < 0; \eta_2 > 1$
(e)

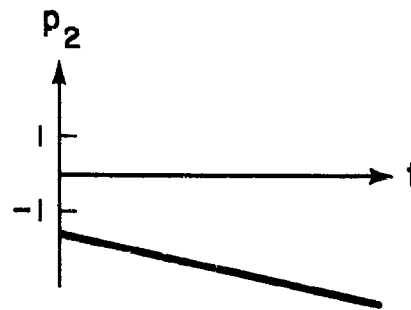

$\eta_1 > 0; \eta_2 < -1$
(f)

FIG. 4 THE SIX POSSIBLE FORMS OF THE FUNCTION $p_2(t) = \eta_2 - \eta_1 t$.

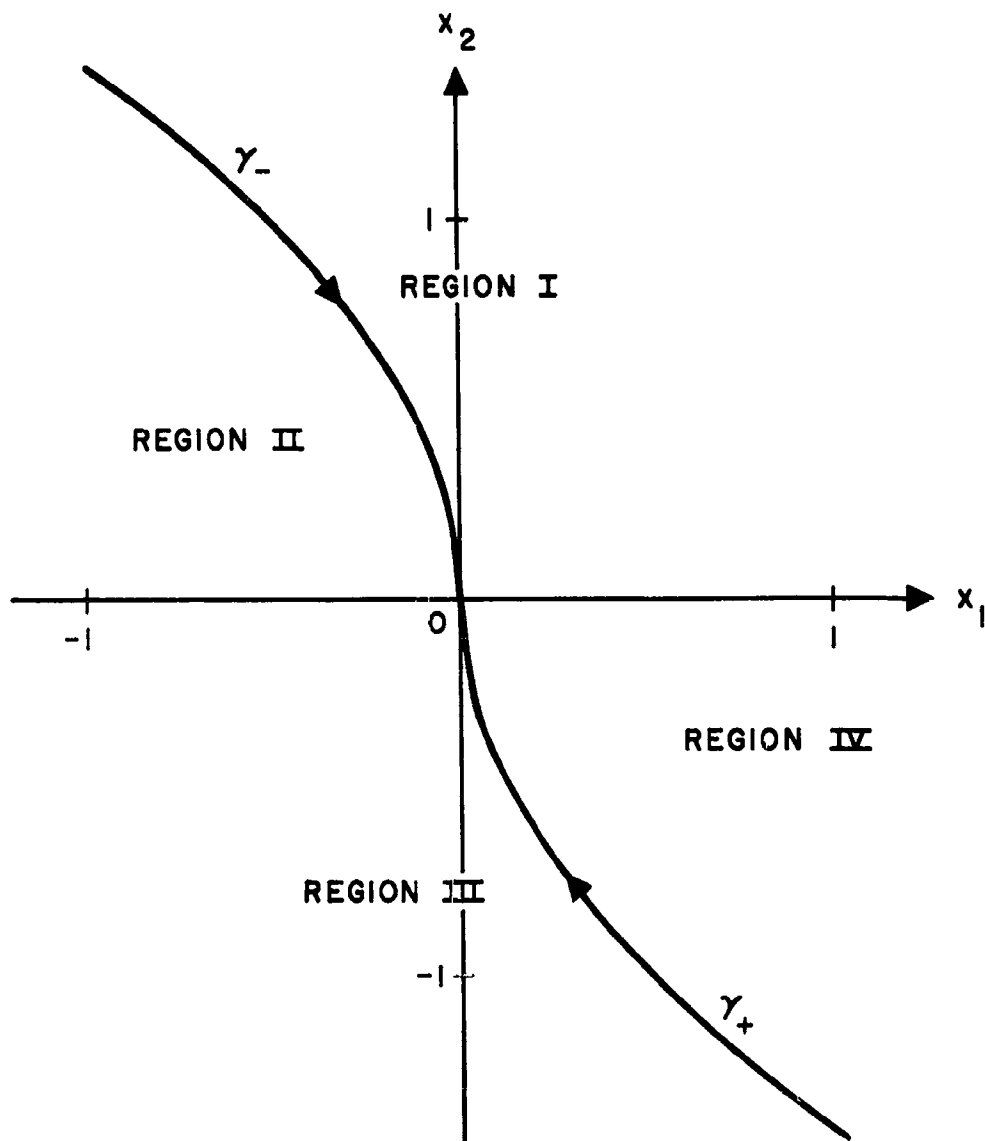

FIG. 5 PLOT OF THE γ_+ and γ_- CURVES DEFINING THE FOUR REGIONS OF OPERATION IN THE PHASE PLANE.

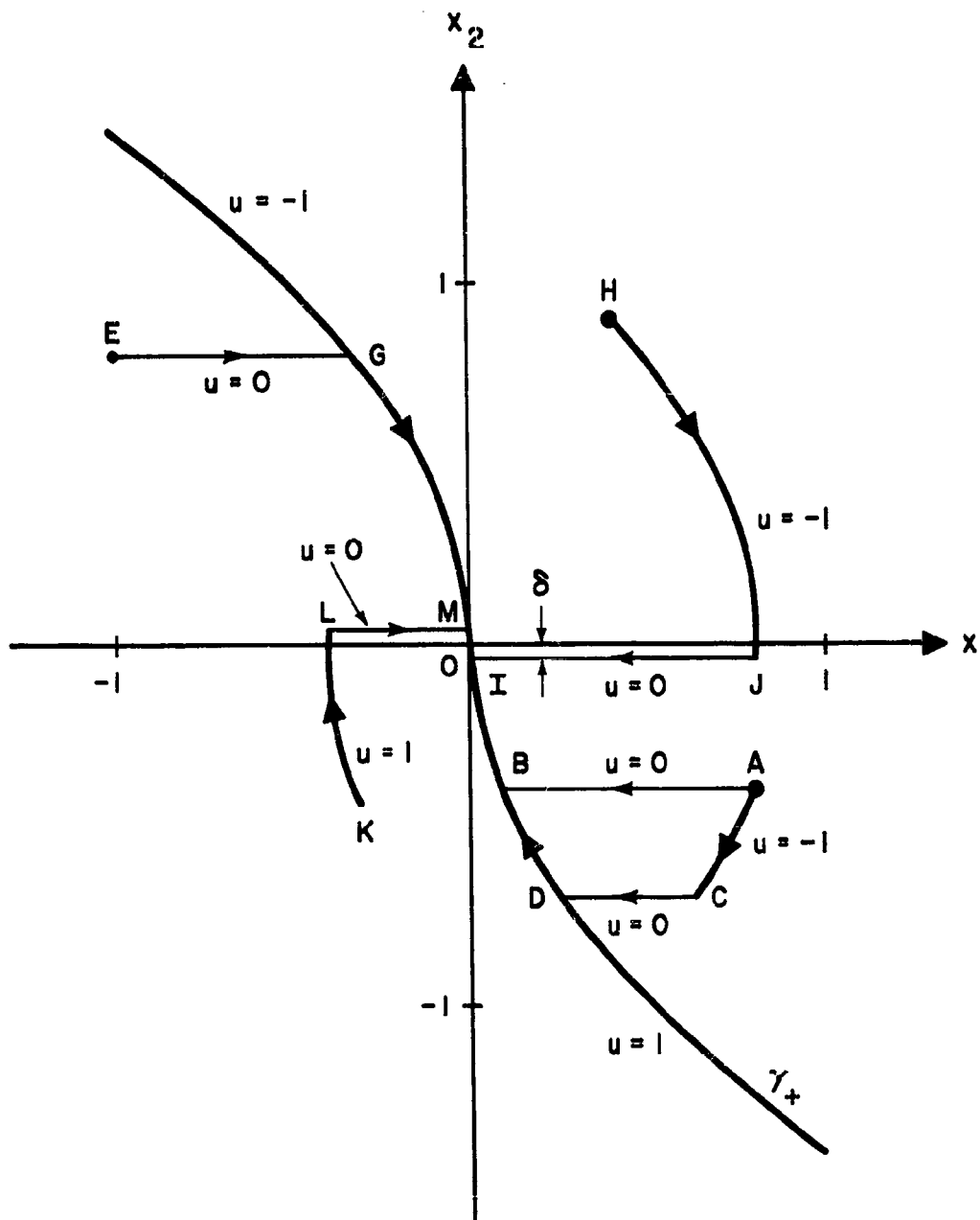

FIG. 6 EXAMPLES OF MINIMUM FUEL TRAJECTORIES
(EXCEPT FOR TRAJECTORY ACDO).

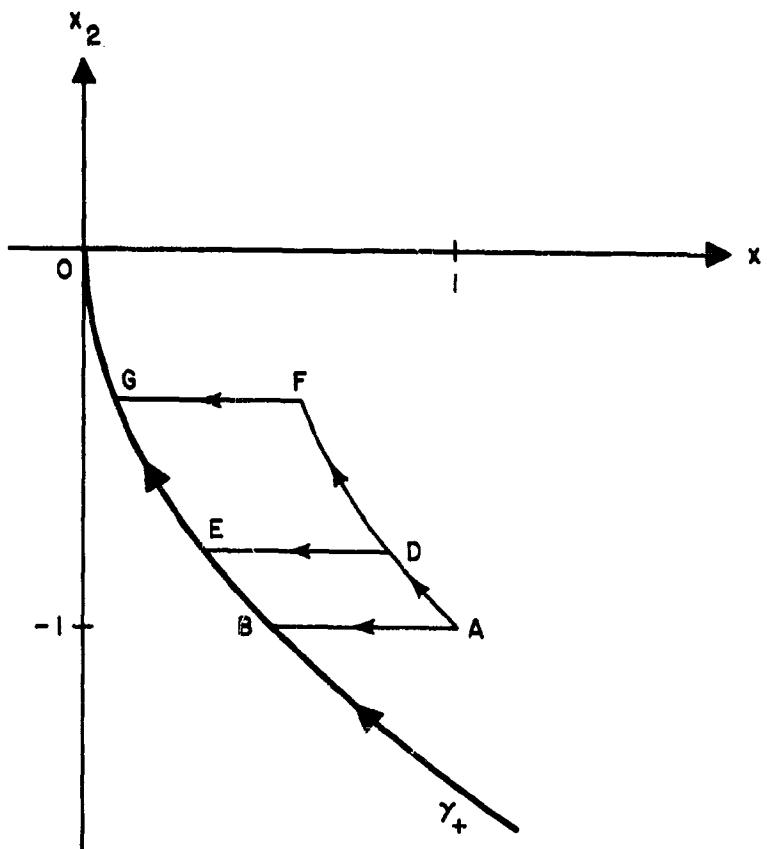

FIG. 7 EXAMPLE OF EQUAL FUEL TRAJECTORIES, WITH DIFFERENT RESPONSE TIMES. (FUEL $F = 1.000$).

3-22-3775

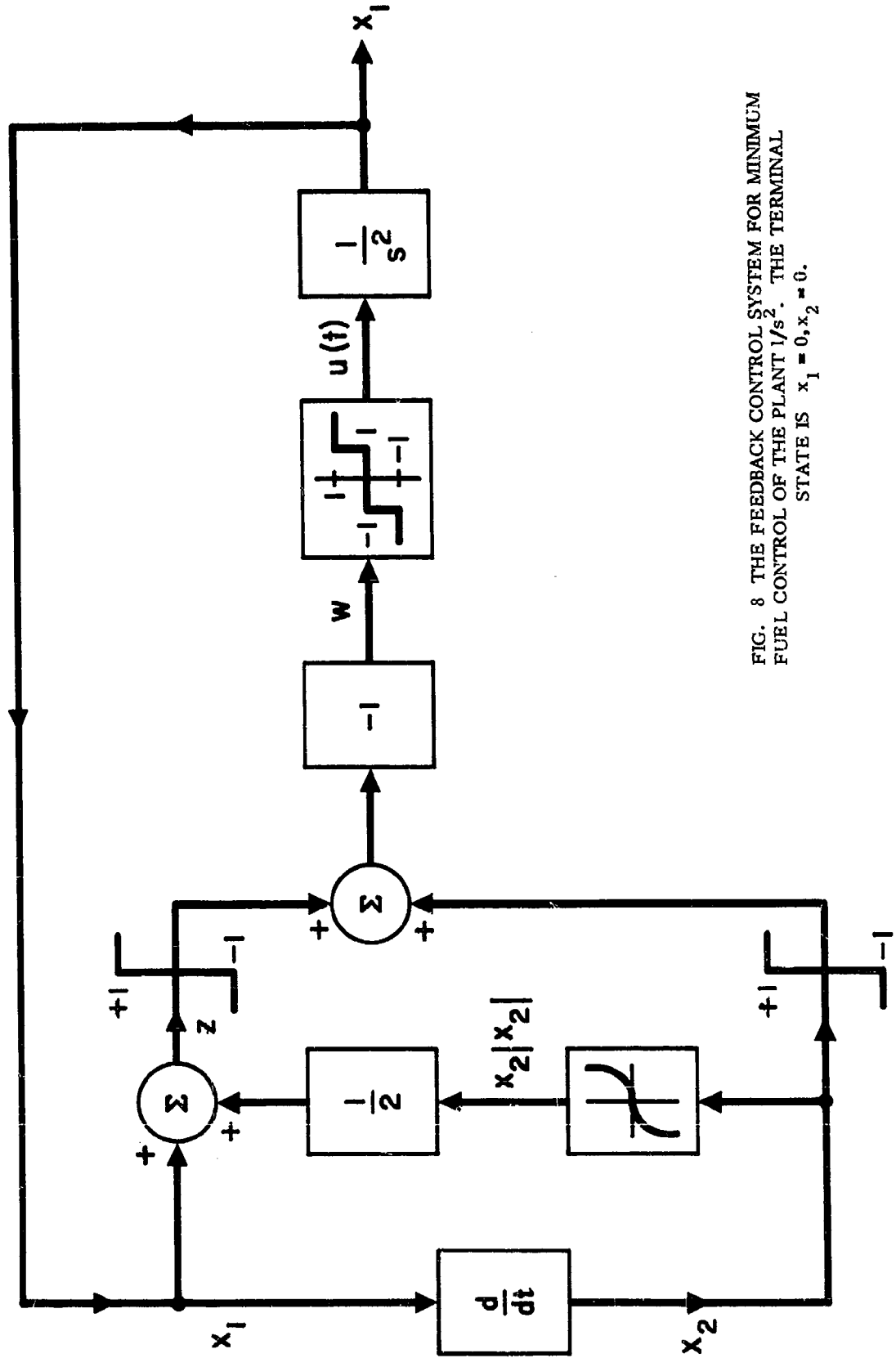

FIG. 8 THE FEEDBACK CONTROL SYSTEM FOR MINIMUM FUEL CONTROL OF THE PLANT $1/s^2$. THE TERMINAL STATE IS $x_1 = 0, x_2 = 0$.

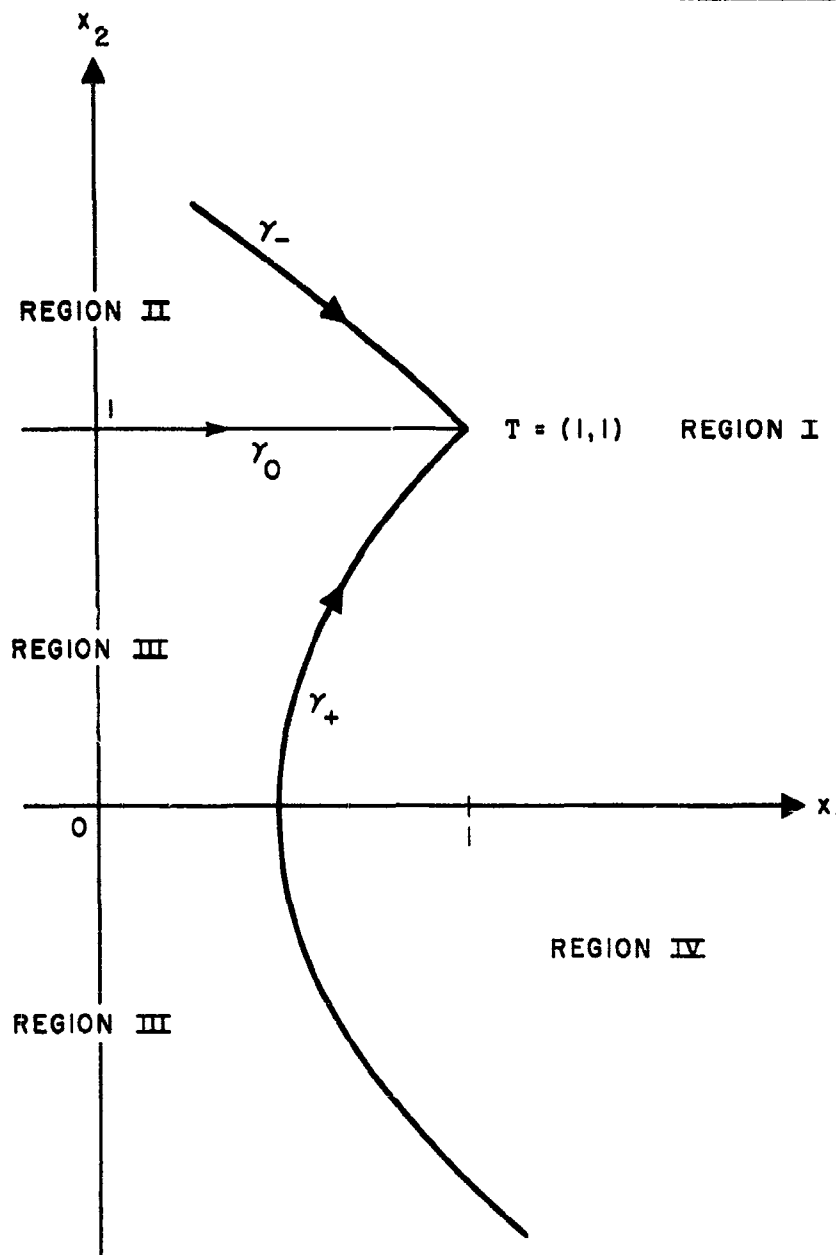

FIG. 9 THE γ_+ , γ_0 , and γ_- CURVES AND THE REGIONS OF OPERATION FOR MINIMUM FUEL CONTROL TO THE TERMINAL STATE $T = (1, 1)$.

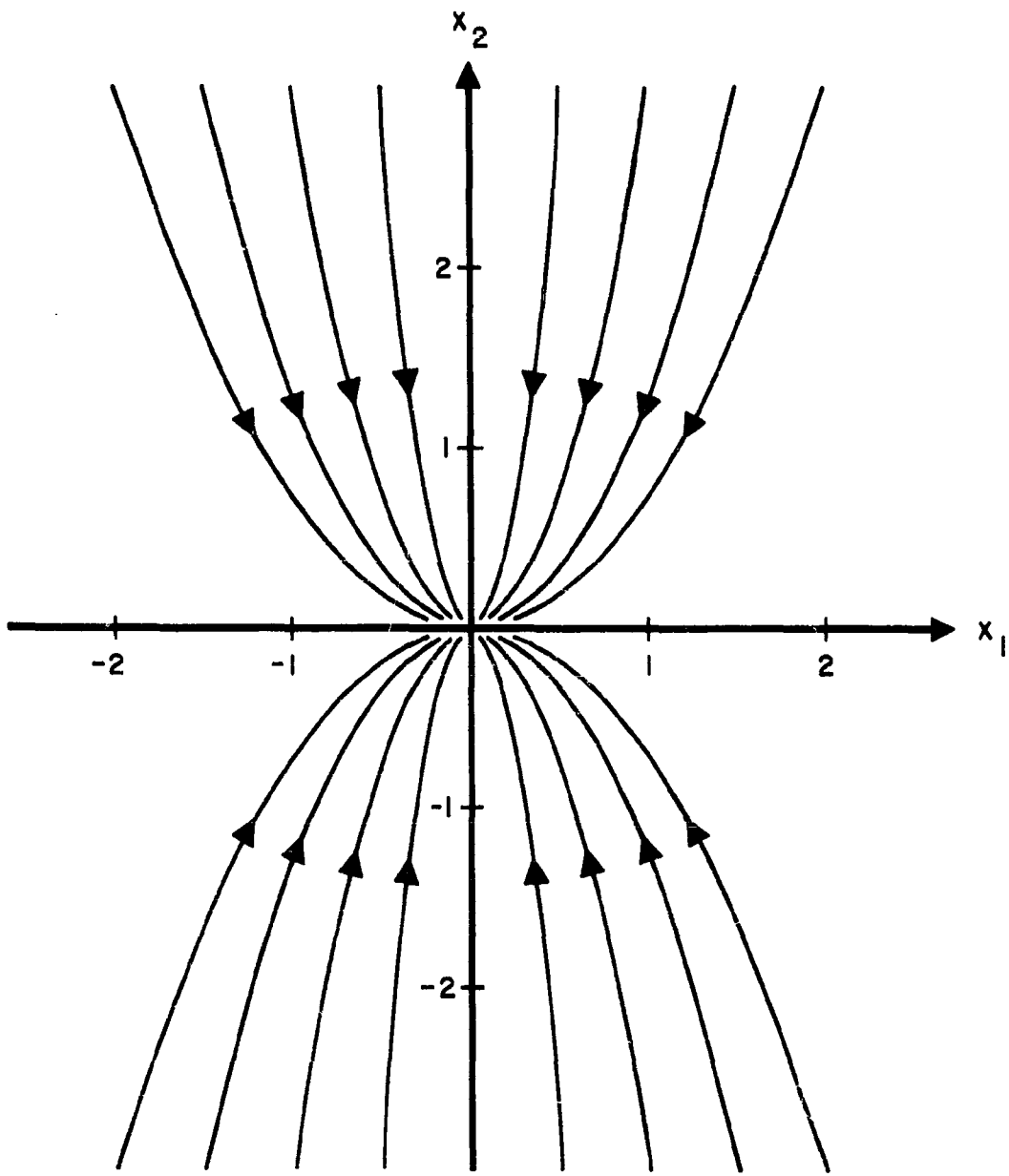

FIG. 10 PHASE PLANE TRAJECTORIES OF $1/(s+1)(s+2)$
FOR $u(t) = 0$.

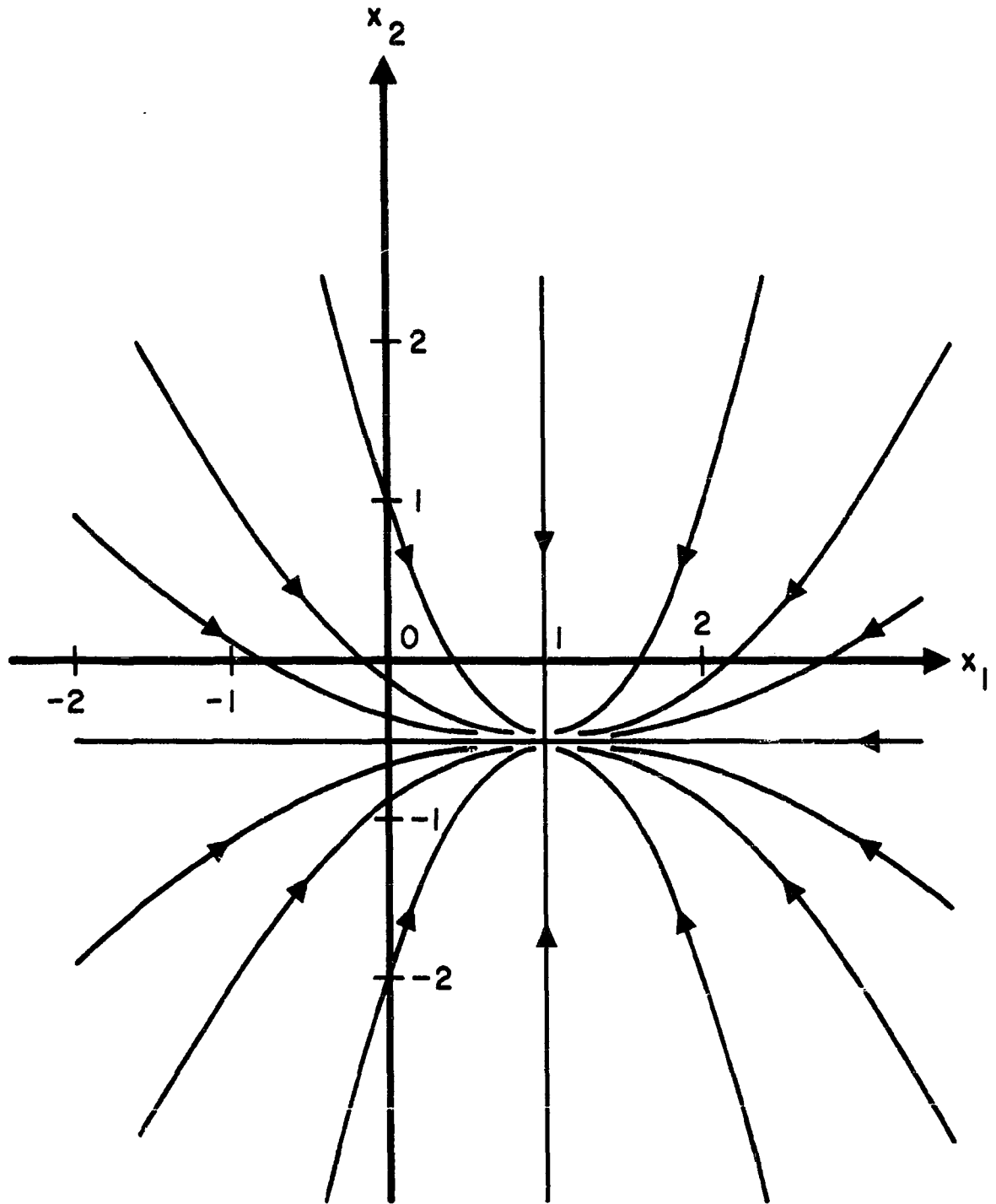

FIG. 11 PHASE PLANE TRAJECTORIES OF $1/(s+1)(s+2)$
FOR $u(t) = +1$.

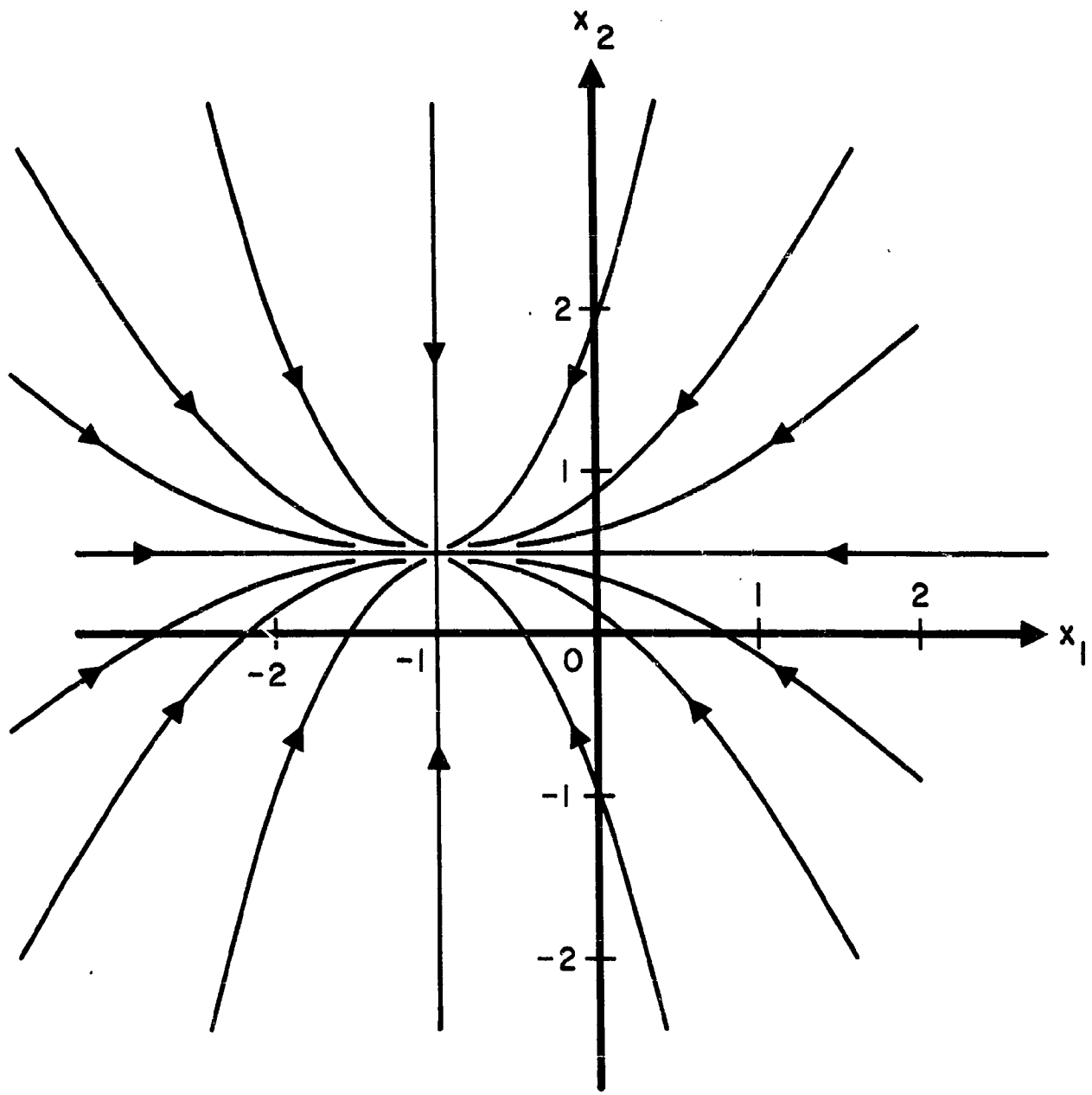

FIG. 12 PHASE PLANE TRAJECTORIES OF $1/(s+1)(s+2)$
FOR $u(t) = -1$.

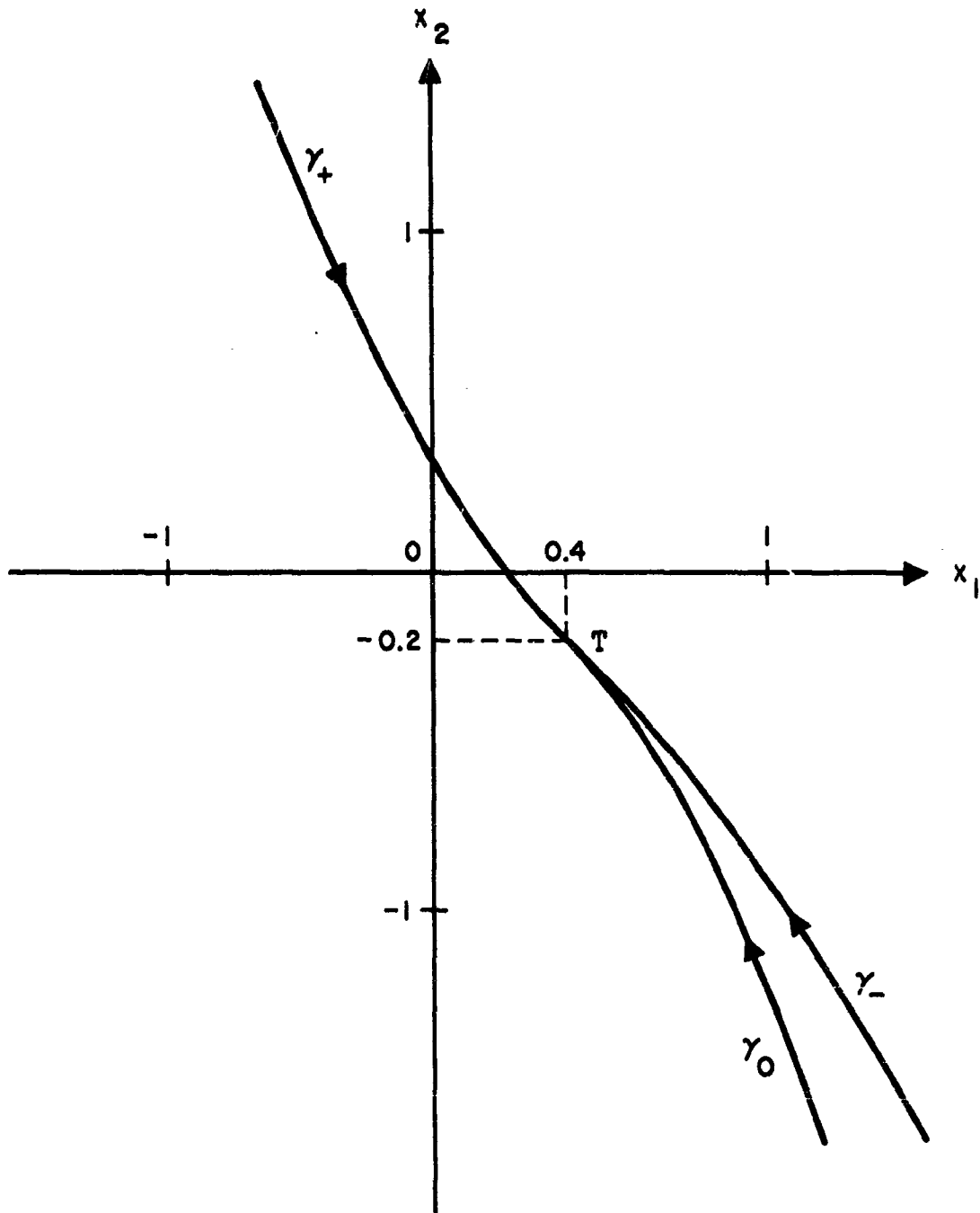

FIG. 13 THE γ_0 , γ_+ , and γ_- CURVES.

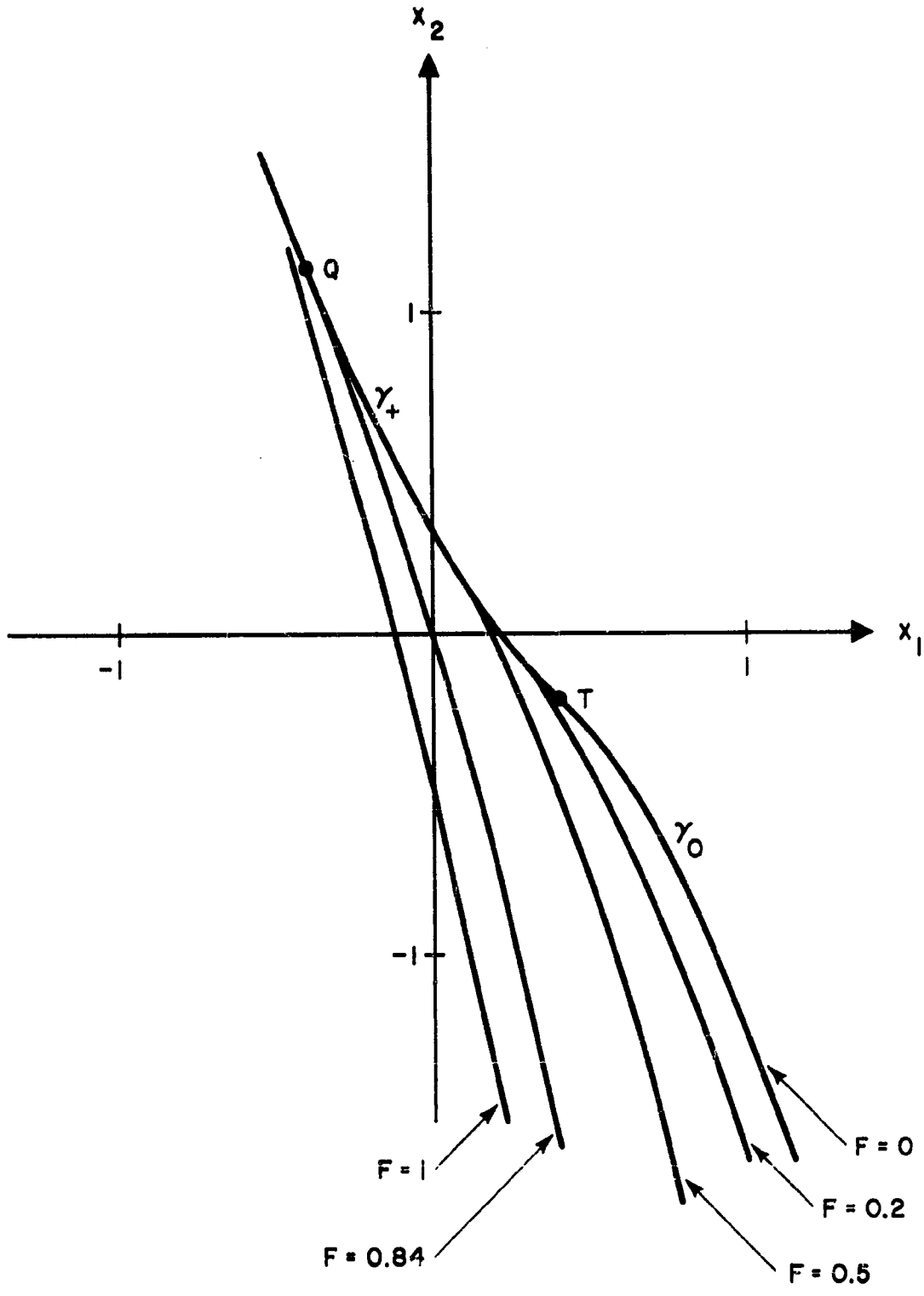

FIG. 14 THE EQUAL FUEL CURVES

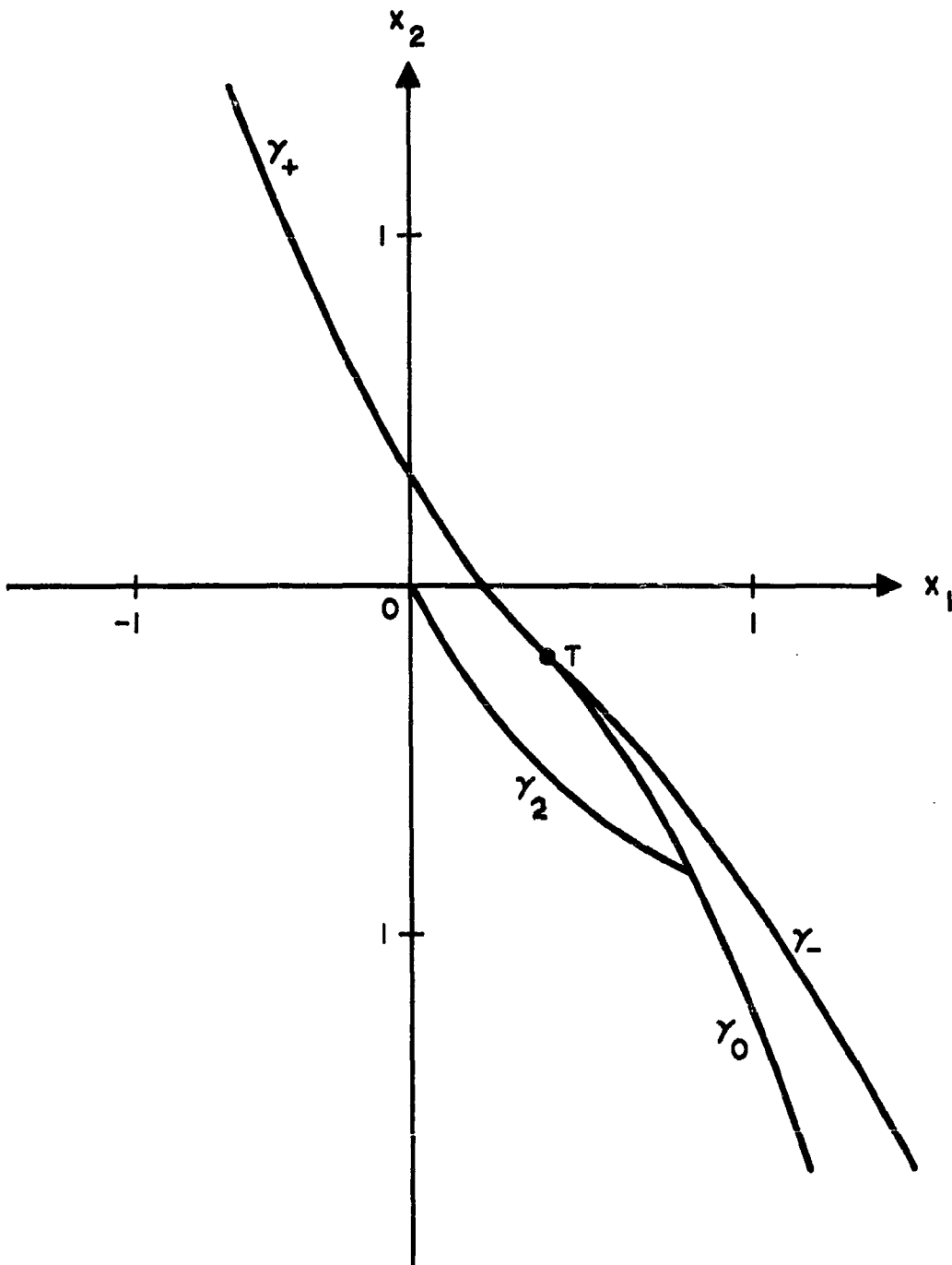

FIG. 15 PLOT OF THE γ_2 CURVE

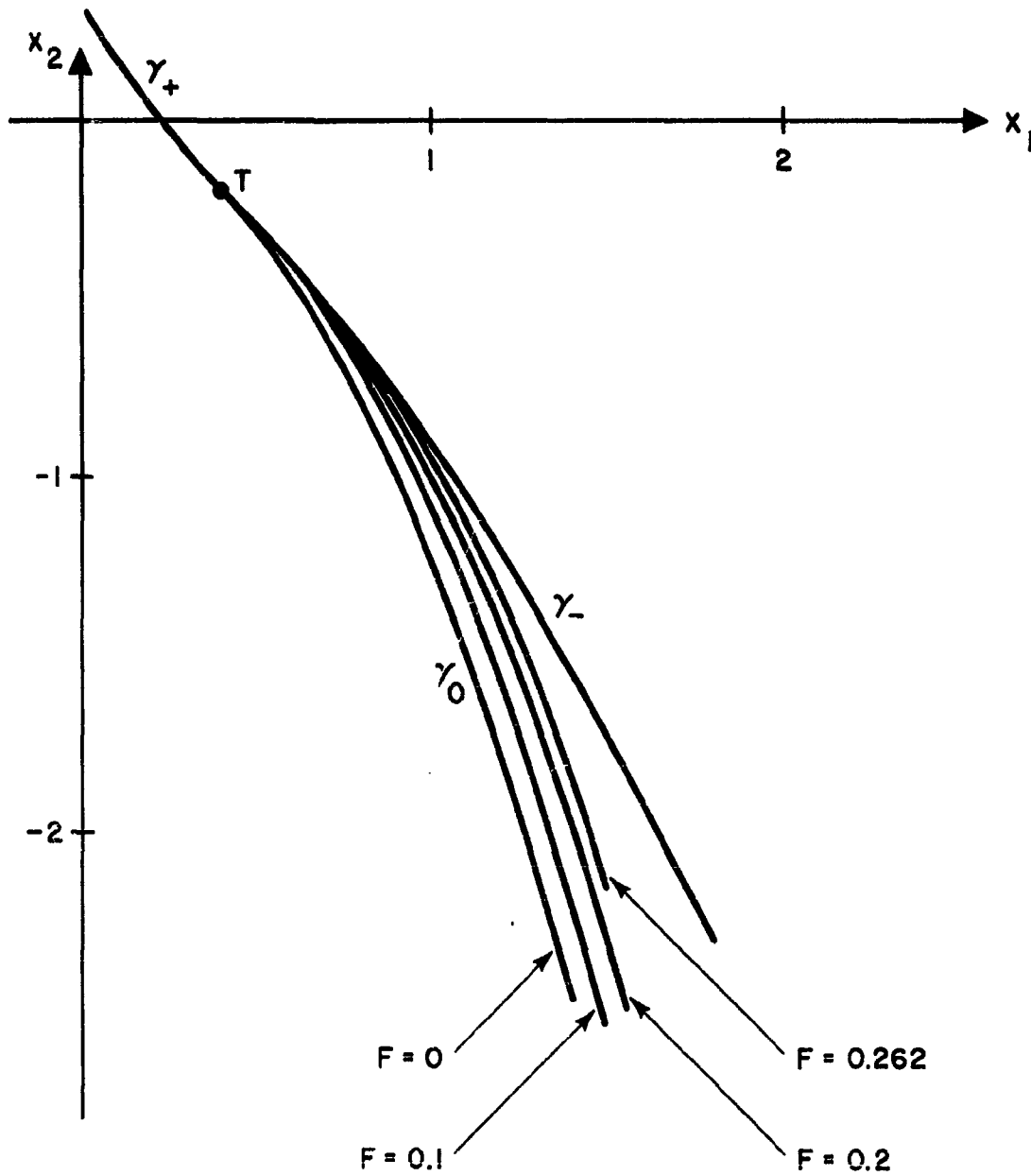

FIG. 16 PLOT OF EQUAL FUEL CURVES

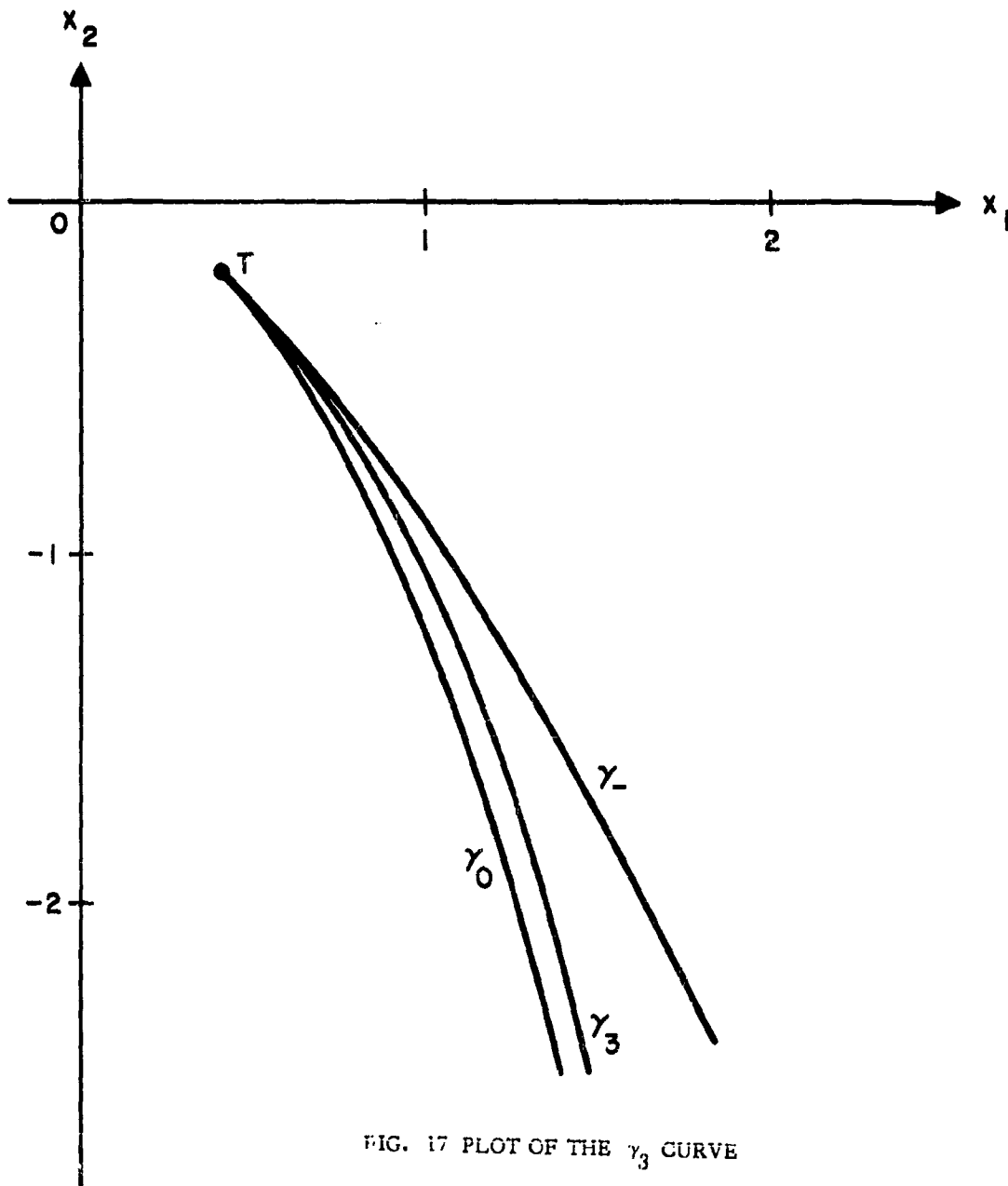

FIG. 17 PLOT OF THE γ_3 CURVE

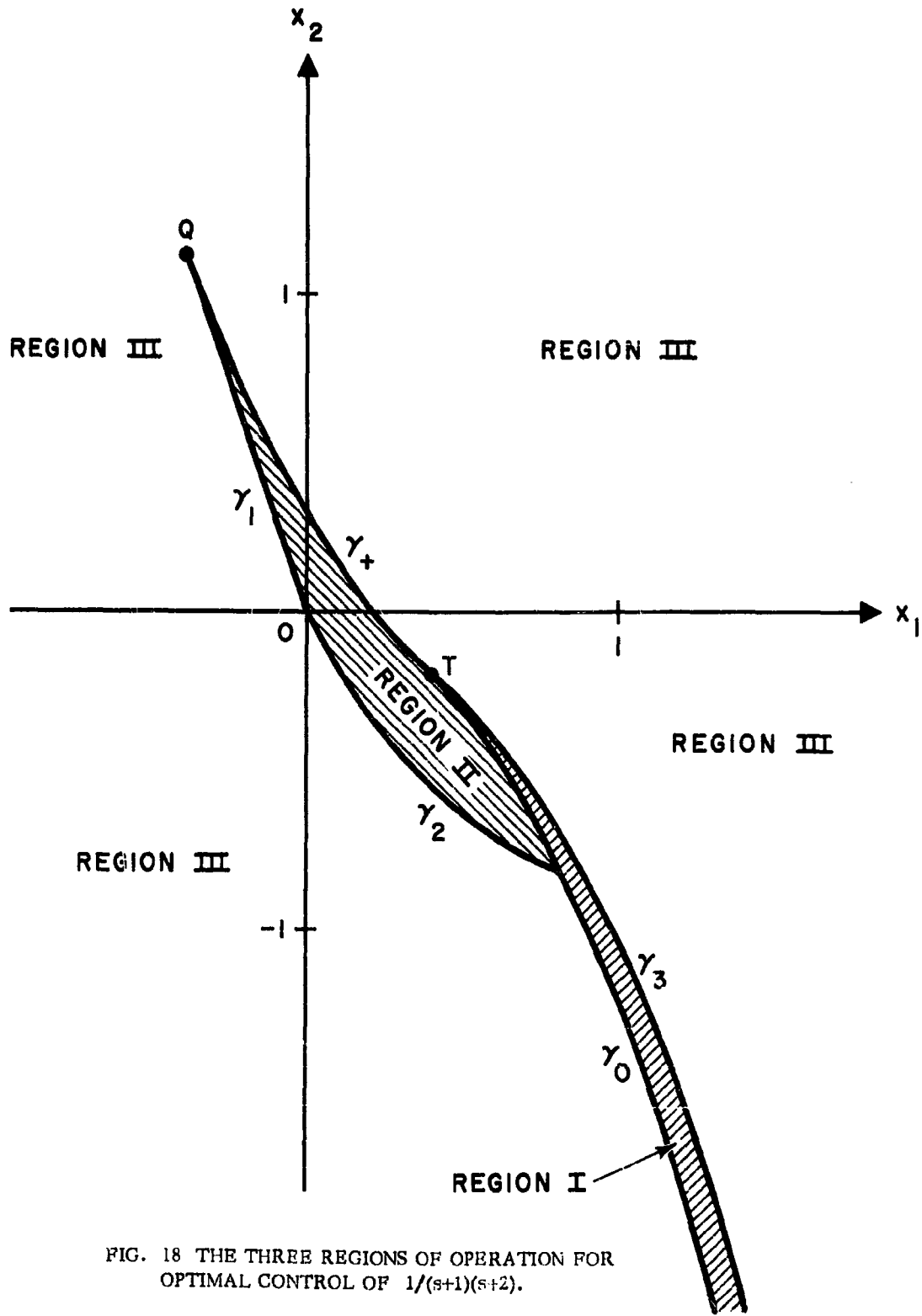

FIG. 18 THE THREE REGIONS OF OPERATION FOR OPTIMAL CONTROL OF $1/(s+1)(s+2)$.

DISTRIBUTION LIST

Division 2

C. R. Wieser
S. H. Dodd

Group 22

V. A. Nedzel
J. F. Nolan
W. I. Wells

M. Athanassiades (40)
A. W. Armenti
Charles R. Arnold
T. C. Bartee
R. J. Bergemann
N. A. Brigham
D. Clapp
P. L. Falb
J. J. FitzGerald
L. A. Gardner
A. A. Grometstein
J. H. Halberstein
R. C. Holland
C. Hopkins
L. Kleinrock
A. Knoll
E. Korngold
H. J. Kushner
W. Z. Lemnios
M. D. Marill
L. M. Meixsell
R. C. Norris
D. Reiner
D. Sakrison
B. J. Schafer

Group 22 (cont.)

F. C. Schweppe
C. W. Uskavitch
J. L. Vernon
J. B. Williams
P. Wood
M. Schneider
D. L. Lovenvirth
D. Schneider
J. M. Winett
A. Freed

Group 25

H. Sherman

Group 28

H. E. Meily
A. J. Morency
J. Slesers

Dr. R. E. Kalman
RIAS Inc.
7212 Bellona Ave.
Baltimore 12, Md.

Dr. E. B. Lee
RIAS Inc.
7212 Bellona Ave.
Baltimore 12, Md.

Prof. L. Zadeh
Dept. of Elect. Engineering
University of California
Berkeley 4, California

Prof. C. A. Desoer
Dept. of Electr. Engineering
University of California
Berkeley 4, California

Prof. O. J. M. Smith
Dept. of Electrical Engineering
University of California
Berkeley 4, California

Prof. E. Polak
Dept. of Electr. Engineering
University of California
Berkeley 4, California

Prof. O. Elgerd
Dept. of Electrical Engineering
University of Florida
Gainesville, Florida

Dr. B. Friedland
Melpar, Inc.
11 Gallen St.
Watertown, Mass.

Prof. Y. C. Ho
Computation Laboratory
Harvard University
Cambridge, Mass.

Dr. M. Masarovic
Case Institute of Technology
Cleveland 6, Ohio

Prof. S. S. K. Chang
Dept. of Electr. Engineering
New York University, New York, N. Y.

Prof. I. Flugge-Lotz
Dept. of Engineering
Stanford University
Stanford, California

Dr. George Lendaris, Defense Systems Div.
General Motors Corp.
Santa Barbara, California

Dr. C. Harvey
Minneapolis Honeywell Reg. Co.
Minneapolis, Minn.

Mr. Jack Wing
Dept. of Electr. Engineering
University of California
Berkeley 4, California

Dr. R. Kalaba
The Rand Corporation
Santa Monica, California

Dr. J. Aseltine
The Aerospace Corp.
Los Angeles, California

Mr. Ken. Blay
Dept T-210-Avco RAD Corp.
Wilmington, Mass.

Mr. Ernest Holzmann
Rm. 116, Bldg. 3., General Electric Co.
Electronics Lab., P. O. Box 1122
Syracuse, New York

Dr. C. Merriam
Research Labs., General Electric Co.
Schenectady, New York

Prof. R. Bach
112 G, Northeastern University., Huntington A
Boston, Mass.

Dr. M. Aoki, Dept. of Engineering
University of California, Los Angeles, Calif.

Also distribute to NASA Distribution List.

UNCLASSIFIED

UNCLASSIFIED