

UNCLASSIFIED

---

---

AD 276 950

*Reproduced  
by the*

ARMED SERVICES TECHNICAL INFORMATION AGENCY  
ARLINGTON HALL STATION  
ARLINGTON 12, VIRGINIA



---

---

UNCLASSIFIED

NOTICE: When government or other drawings, specifications or other data are used for any purpose other than in connection with a definitely related government procurement operation, the U. S. Government thereby incurs no responsibility, nor any obligation whatsoever; and the fact that the Government may have formulated, furnished, or in any way supplied the said drawings, specifications, or other data is not to be regarded by implication or otherwise as in any manner licensing the holder or any other person or corporation, or conveying any rights or permission to manufacture, use or sell any patented invention that may in any way be related thereto.

276 950

# AUXILIARY PROPELLED

## 105<sub>MM</sub> HOWITZER

CONCEPT, FEASIBILITY AND DESIGN STUDY

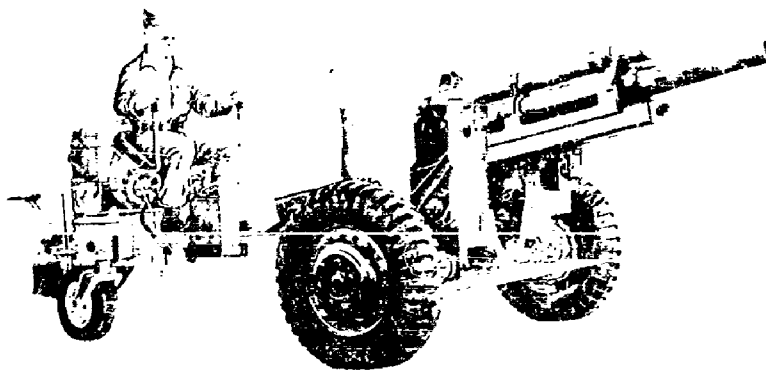

SUNDSTRAND AVIATION

DIVISION OF SUNDSTRAND CORPORATION

**SUNDSTRAND**

Sundstrand Aviation  
Division of Sundstrand Corporation

F I N A L   T E C H N I C A L   R E P O R T

DESIGN, AND DETAIL OF AN  
AUXILIARY - PROPELLED 105 mm HOWITZER

Phase II

Contract DA-11-070-508-ORD-1343  
P.O. 61-5323

Under the Technical Supervision of the Project Officer,  
Rock Island Arsenal

Under the Cognizance of Chicago Ordnance District

Written By:

W. J. Zwierzycki  
W. J. Zwierzycki  
Project Engineer

Approved By:

P. G. Myers  
P. G. Myers  
Group Engineer

Submitted By:

J. E. French  
J. E. French  
Contract Program Manager

E. W. Kruger  
E. W. Kruger  
Section Manager

E. W. Erikson  
E. W. Erikson *By D.A.S.*  
Chief Engineer

April 1962



TABLE OF CONTENTS

Table of Contents	1
List of Figures	11
List of Drawings	11
Abstract	111
A. Introduction	1
B. Review of Phase I	1
C. Overall Considerations	4
1. Final Drive Ratio.....	4
2. Weapon Top Speed.....	5
3. Weapon Range.....	5
4. Splitter Drive Ratio.....	5
5. Line Losses Due to Oil Flow.....	6
6. System.....	7
7. Summary.....	9
D. Component Design and Selection	9
1. Pumps.....	9
2. Motors.....	9
3. Engine.....	10
4. Splitter Drive.....	10
5. Final Drive.....	12
6. Hydraulic Lines and Fittings.....	13
7. Reservoir.....	14
8. Pivot Wheel and Bracket.....	14
9. Trail Jack.....	15
10. Seal.....	15
11. Foot Rest.....	15
E. Drawings	16
F. Conclusions	16
G. Recommendations	16
H. Appendix	21

## LIST OF FIGURES

<u>Figure Number</u>	<u>Description</u>	<u>Page</u>
I	Characteristics of Several Systems	3
II	General Schematic	8
III	Performance of the Auxiliary Propelled 105mm Howitzer	11

## LIST OF DRAWINGS

<u>Drawing Number</u>	<u>Description</u>	<u>Page</u>
4000105	Auxiliary Propulsion Installation	17,18
4000115	Splitter Drive Assembly	19
4000128	Final Drive Assembly, R.H.	20

## A. INTRODUCTION

The general objective of this contract is to perform engineering concept, feasibility and design studies of an Auxiliary - Propelled 105mm Howitzer Carriage, M2A2.

In this connection, during Phase I Airborne Operations, it is important that weapon systems be built with as much utility as possible. These systems must be light, compact, mobile and have the ability to be employed immediately. It is, therefore, a definite advantage to be able to air drop a 105mm Howitzer that could provide its own mobile power, rather than relying on a separate prime mover.

An auxiliary propelled weapon is capable of meeting the requirements mentioned in the preceding paragraph and, in addition, of providing mobility superior to that of the towed weapon in cross country operation. An auxiliary propelled weapon is capable of operating in mud conditions and through wooded areas that would halt a towed weapon.

Phase I of this contract examined the concept, established the feasibility and completed initial design studies. Phase II of the contract provides for the design of a prototype system. In addition, Phase II provides that layouts and drawings be furnished to the technical supervisor at Rock Island Arsenal.

## B. REVIEW OF PHASE I

Desired and required operating modes were set forth in Phase I of the contract to serve as guides in examining the concept of applying an auxiliary propulsion system to the 105mm Howitzer. Such items as weapon top speed, negotiable mud depth, negotiable slopes, range, fordability, operation at high altitudes and added weight were specified.

Preliminary calculations were made to define the range of horsepower required to provide the desired performance. This information was then used to examine energy sources, prime movers, power transmissions and propulsion methods. Unconventional units and items still in the basic research stage were examined as well as conventional units. From this study a military standard gasoline engine, a hydrostatic transmission and conventional tires were determined to be the best suited for the application.

Considerable work was done in examining the mobility of various tires in cross country operation. Because of the nature of the calculations involved, a computer program was developed to examine as many tire and soil combinations as possible. From this study it was felt that the wheel must have an input torque of 48,600 in-lbs to meet severe conditions.

On this basis a number of hydrostatic transmissions were studied to determine the one best suited to the application. Figure I, page 3, summarizes several of the systems; their components, operating characteristics and weights are tabulated. From this work, the system listed in the second column was selected to be used in the preliminary design studies. This selection was made because the system most nearly met all of the "desired" performance requirements of the contract. This system also used the largest motor and thereby presented the most installation problems. The fact that it was possible to prepare drawings showing this system installed on the weapon clearly demonstrated the feasibility of applying an auxiliary propulsion system to the 105mm Howitzer.

Eleven installation, layout and outline drawings showing this system and its major components were presented in the final report covering Phase I. In addition, two pictorial drawings were included showing the auxiliary propelled weapon in its firing and travelling modes of operation.

At the conclusion of Phase I, a meeting was held between Rock Island Arsenal personnel and Sundstrand personnel in which the results of the study were discussed. The systems shown in Figure I, and others were discussed. and on the basis of this discussion the system shown in the last column of Figure I was selected as the system to be pursued further. Modification 1 to the contract was then prepared to encompass the design and detailing of this system. This work is defined as Phase II of the contract.

**FIGURE I**  
**SEVERAL POSSIBLE AUXILIARY P**  
**SYSTEMS FOR THE 105mm HO**

SYSTEM COMPONENTS

Engine	4A032	2A042
Pumps	1.00 V	1.00 V
Motors	1.00 F	4.47 V
Final Drive Ratio	45.2:1	20.5:1
Splitter Drive Ratio	1:1	1:1
Hydraulic Line I. D. Inches	.75	.75

SYSTEM OPERATING CHACTERISTICS

Maximum Torque/Wheel, in-lbs	21,600	48,600
Maximum Weapon Speed, MPH	9.1	15
Maximum System Pressure, PSI	3,000	3,600
Pump RPM	4,000	4,000
Maximum Motor RPM	3,600	2,985
Maximum Oil Flow, GPM	17.3	17.3

SYSTEM WEIGHT

Engine & Accessories	113.1	183.6
Pivot Wheel & Related Parts	92.7	140.0
Trail Jack & Related Parts	10.3	16.3
Seat	10.9	10.9
Splitter Drive & Related Parts	30.4	32.7
Pumps (2)	76.0	80.0
Motors (2)	53.2	190.0
Hydraulic Components	74.9	113.5
Final Drives (2)	110.6	119.8
Controls	8.0	43.0
Sub Total	580.1	929.8
Brakes	- 101.3	- 101.3
Total Estimated Weight, lbs.	478.8	828.5

1

FIGURE I

POSSIBLE AUXILIARY PROPULSION

EMS FOR THE 105mm HOWITZER

2A042	2A042	2A042	2A042	2A042	2A042
1.00 V	1.65 V	2.71 V	1.00 V	1.00 V	3.2 V
4.47 V	1.65 F	2.71 F	1.00 F	2.71 V	3.2 F
20.5:1	46.4:1	28.2:1	76.25:1	28.2:1	37.2:1
1:1	1.3:1	1:1	1.5:1	.65:1	.63:1
.75	1.0	1.25	.75	.5	1.0
48,600	48,600	48,600	48,600	48,600	48,600
15	12.5	15	8.1	15	7.7
3,600	4,000	4,000	4,000	4,000	3,000
4,000	5,200	4,000	6,000	2,600	2,500
2,985	4,680	3,600	5,400	3,700	2,500
17.3	37	47	26	11.2	34.7
183.6	183.6	183.6	183.6	183.6	183.6
140.0	140.0	140.0	140.0	140.0	140.0
16.3	16.3	16.3	16.3	16.3	16.3
10.9	10.9	10.9	10.9	10.9	10.9
32.7	32.7	32.7	36.4	32.7	36.8
80.0	90.0	120.0	76.0	80.0	126.0
190.0	65.0	95.0	53.2	120.0	90.0
113.5	138.5	153.5	113.5	96.0	120.0
119.8	136.0	119.8	136.0	136.0	140.0
43.0	8.0	8.0	8.0	43.0	10.0
929.8	821.0	896.0	773.9	858.5	873.6
- 101.3	- 101.3	- 101.3	- 101.3	- 101.3	- 101.3
828.5	719.7	794.7	672.6	757.2	772.3

### C. OVERALL CONSIDERATIONS

The work done in Phase I and the meeting at its conclusion resulted in the following decisions pertaining to the auxiliary propulsion system to be designed and detailed in Phase II.

1. Pumps shall be Sundstrand Model 32PVL-4000 units
2. Motors shall be Sundstrand Model 32MC-4000 units
3. Torque input to each wheel shall be in the range of 48,600 in-lbs.
4. The model 2A042 military standard engine shall be used with brackets and spacing of components such that the 4A042 engine may be interchanged with relatively little modification. One engine is to be used per weapon.
5. Top weapon speed shall be approximately 8 mph.

These five factors pretty well define the auxiliary propulsion system and its operating characteristics. The selection of the motors and the wheel input torque define the final drive ratio in the following manner.

#### 1. Final Drive Ratio

The maximum pressure the motor is designed to handle safely as a normal working pressure is 3000 psi. With an outlet pressure of 120 psi, the maximum pressure drop across the unit becomes 2880 psi. The torque that the motor is theoretically capable of developing is given by  $T = \frac{\Delta P \times \text{Displacement}}{2\pi}$

Maximum torque can be developed only at low speeds due to engine horsepower limitations. At low speeds the oil flow is also low since speed is proportional to flow and the flow losses in the lines, which lower the  $\Delta P$  available at the motor to do work, may safely be neglected. On this basis then,  $T = \frac{2880 \times 3.2}{2\pi}$

$$T = 1470 \text{ in-lbs} \\ \text{(theoretical)}$$

Assuming a 92% motor torque efficiency, 1360 in-lbs will actually be developed. Further assuming a final drive efficiency of 97.5% a final drive ratio of:

$$\frac{48,600}{1360 \times .975} : 1 \text{ or } 36.7:1 \text{ is required.}$$

## 2. Weapon Top Speed

The tire used on the 105mm Howitzer is the 9.00 x 20 Nondirectional Cross Country (NDCC) type. As loaded by the 105mm Howitzer it has a 19.2" rolling radius. Then,

$$\frac{5280}{2\pi \times \frac{19.2}{12}} = 525 \text{ tire revolutions/mile}$$

$$\frac{525}{60} = 8.75 \text{ tire rpm/mpg}$$

and  $8.75 \times 36.7 = 321 \text{ motor rpm/mpg}$ .

Since the maximum motor speed is limited to 2400 rpm, the top weapon speed is  $\frac{2400}{321} = 7.5 \text{ mph}$ .

## 3. Weapon Range

Fuel consumption curves for the 2A042 (17.06 max. hp) and the 4A084 (35 max. hp) show that they require .70 and .69 lbs/hour respectively at 3600 rpm and maximum horsepower output. At maximum horsepower output, then, they consume 12.3 and 24.2 lbs of fuel per hour, respectively. With a five gallon fuel supply they are capable of operating for 2.68 and 1.37 hours at maximum horse power output. If this time is all spent at the maximum speed, the weapon's range becomes 20 and 10.3 miles respectively. The range at maximum horsepower output at lower speeds is reduced proportionately. At lower horsepower requirements, the range is increased at any given speed.

## 4. Splitter Drive Ratio

A single engine is used to drive two pumps. Since the pumps are limited to a maximum speed of 2500 rpm and the engine has a maximum speed of 4000 rpm, a 1.6 reduction ratio must be provided between the engine and pumps.

## 5. Line Losses Due to Oil Flow

At a speed of 2500 rpm and maximum displacement, the pump is capable of delivering  $\frac{3.2 \times 2500}{231} = 34.7$  gpm

assuming 100% volumetric efficiency. The inside diameter of the hydraulic lines required to keep the maximum oil velocity below 15 fps may be found from

$$ID = \sqrt{\frac{GPM}{36.7}} = \sqrt{\frac{34.7}{36.7}} = .973" \text{ or } 1 \text{ inch.}$$

The hydraulic fluid used in the system is MIL-H-5606. At 150°F its absolute viscosity is 8.4 centipoise and its specific gravity is 0.85. Assuming (1) an equivalent line length of 100 feet, to at least partially account for the fittings that are used, and (2) a line coefficient of friction of 0.035, the main circuit drop in pressure may be calculated.

$$\begin{aligned} \Delta P &= 0.0215 \times \frac{f \times SG \times 62.4 \times GPM}{ID^5} \\ &= 0.0215 \times \frac{0.035 \times 0.85 \times 62.4 \times 34.7}{1.0} \end{aligned}$$

$$\Delta P = 48 \text{ psi}$$

Maximum displacement, used in this calculation corresponds to the top weapon speed. To convert this loss to horsepower,

$$\begin{aligned} HP &= \frac{\Delta P \times GPM}{1715} \\ &= \frac{48 \times 34.7}{1715} \end{aligned}$$

$$HP = 0.97 \text{ loss at maximum speed.}$$

For the 2A042 engine, this loss amounts to 6% at maximum horsepower output; for the 4A084 engine, 3%.

If the line size were reduced from one inch to .875 inch the fluid velocity would increase to 19 fps, the  $\Delta P$  loss would be 96 psi and 1.95 hp would be lost at maximum speed. For the 2A042 engine this would represent an 11% loss. With a .750 inch line, these factors would become 26 fps, 202 psi, 4.08 hp and 23% respectively.

## 6. System

Figure II, page 8 , shows the general schematic of the auxiliary propelled 105mm Howitzer. Major components discussed to this point are shown and labelled. The details of the hydraulic circuit are also shown.

## 7. Summary

Figure II also summarizes the work of this section. The calculations are presented in tabulated form in the Appendix.

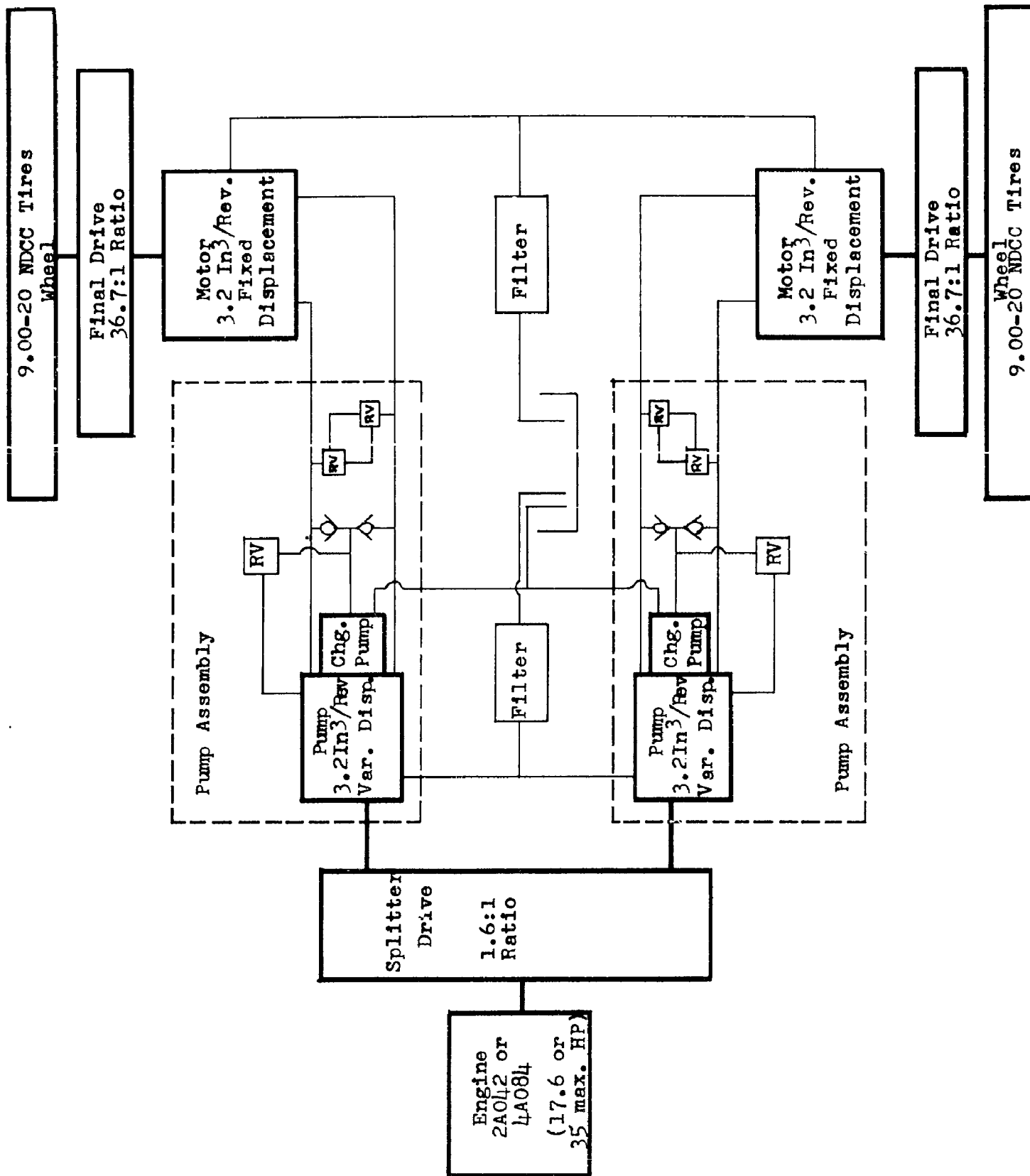

FIGURE II  
GENERAL SCHEMATIC  
AUXILIARY PROPELLED 105mm HOWITZER

## D. COMPONENT DESIGN AND SELECTION

In the design and arrangement of the individual components, the requirements of the auxiliary propulsion system in such matters as strength, speeds, life, size and weight were considered along with commercial availability. Commercially available items were used to the maximum extent possible.

### 1. Pumps

As indicated in the concept and feasibility study final report, there are theoretically an infinite number of pumps that would perform satisfactorily in the auxiliary propulsion system. The choice narrows down considerably when only commercially available units are considered. Of the commercially available units the Sundstrand Model 32PV pump was selected for use, primarily on the basis of its performance on the auxiliary propelled 155mm Howitzer. Besides its performance, the use of this unit is desirable from the logistics viewpoint; i.e., fewer spares and service parts are necessary to service both auxiliary propelled weapons.

These pumps are axial piston variable displacement units, with a maximum displacement of 3.2 cubic inches per revolution "forward" or "reverse". They may be operated at pressures up to 3000 psi and speeds up to 2500 rpm.

A certain amount of accessory equipment is essential to complete the hydraulic circuit with the motor. This equipment consists of a charge pump, charge pump relief valve, check valves, and main circuit relief valves. All of this equipment is an integral part of the pump.

### 2. Motors

Again, as indicated in the concept and feasibility study final report, there are, theoretically, an infinite number of motors that, with the proper final drive ratio, could be used. Of the commercially available units, the Sundstrand Model 32 MC motor was selected for use for the reasons set forth in the preceding section. In this application the added complexity of using a variable displacement (or bi-displacement) motor was not justified since all that would be gained would be an increase in the top weapon speed from 7.5 to slightly over 9 mph.

These motors are axial piston fixed displacement units, 3.2 cubic inches per revolution displacement and capable of operating at pressures up to 3000 psi and speeds up to 2400 rpm.

### 3. Engine

The choice of an engine as the prime mover was made during the concept and study after an examination of many conventional and unconventional power sources. The only other prime mover that warranted consideration was the gas turbine which was eliminated from consideration on the basis of its high fuel consumption. Fuel consumption of the gas turbine has not improved sufficiently in the period since the concept and feasibility study to warrant its further consideration **at this time.**

As recommended in the concept and feasibility study report, a military standard engine will be used. The 2A042 (17.5 max. hp) and the 4A084 engines will both be tried to determine if the added performance using the 4A084 engine is sufficient to justify its use. There is a 50 lb. weight penalty in its use. This added performance to be expected is shown in the area between the two engine lines in Figure III, page 11.

It is seen from this figure that the limits of performance in the form of maximum torque and top weapon speed are not improved by use of the larger engine. The speed at which the maximum torque can be developed and the grade the weapon can negotiate at maximum speed are increased. Whether these increases are important in the actual operation of the weapon will be evaluated. To change from one to the other involves moving one bracket and reassembly of the splitter drive.

Both engines operate at a governed speed of 3600 rpm (Nominal), 4000 rpm (maximum). They are equipped with Donaldson Company, Inc. #5001P2 mufflers. Two mufflers are used on the 4A084 engine, one on the 2A042.

### 4. Splitter Drive

The use of a single engine to drive two pumps requires a splitter gearbox. In order to reduce the 4000 rpm (max.) engine speed to the 2500 rpm (max.) that the pumps are capable of turning, a .625 (output/input) gear ratio is necessary.

The pumps to be used have a displacement controlling shaft that can come out either wobbler trunnion. The operator's control levers (or other actuating means) are intended to fasten to these shafts. The most

Figure III

AUXILIARY PROPULSION SYSTEM CHARACTERISTICS

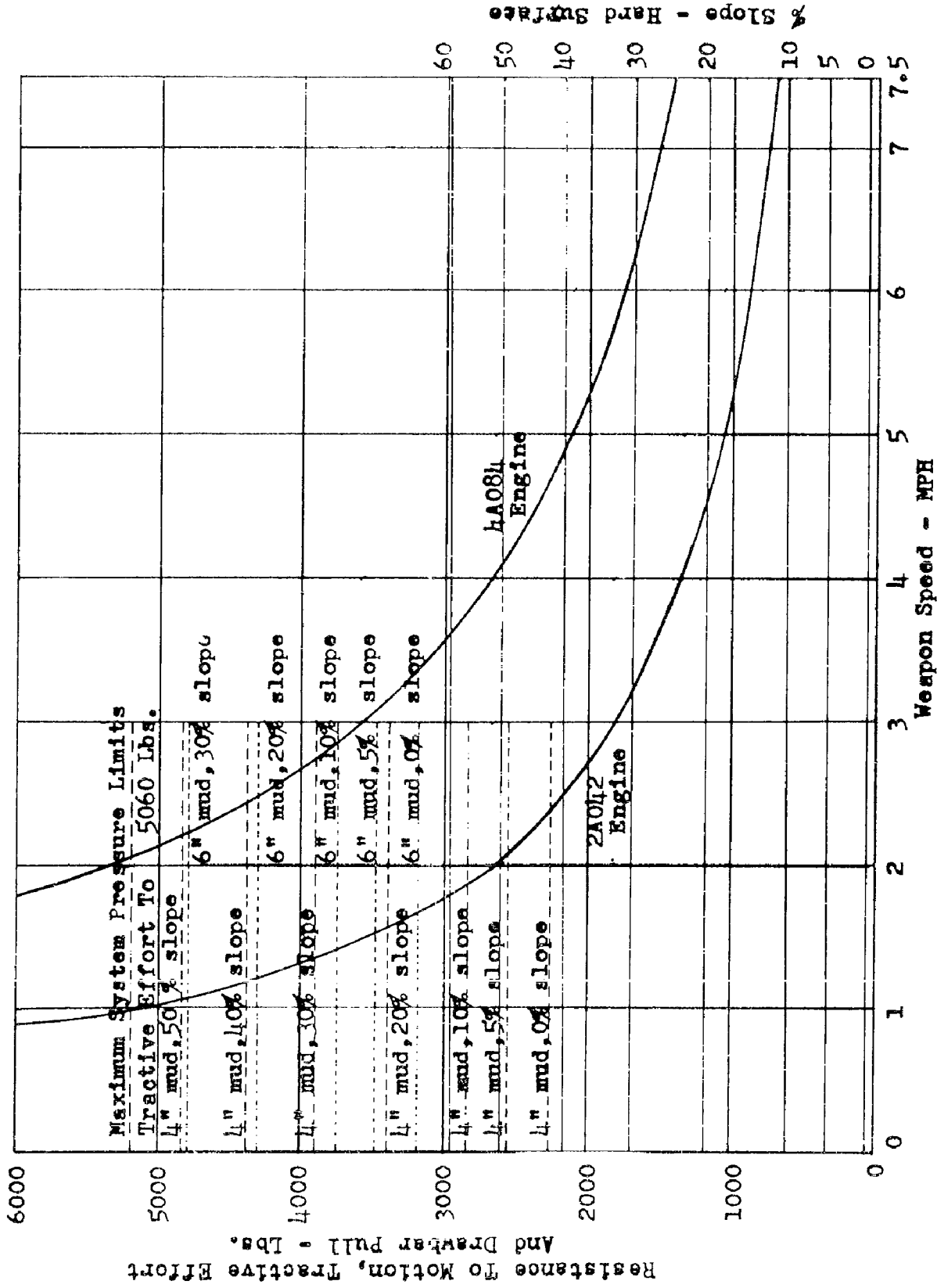

straight forward approach is to have the pumps side by side with the displacement controlling shafts away from each other and spaced so straight levers can be properly located for convenient operation.

These factors establish the splitter gearbox design in broad terms and all that remains is to size the gears for adequate strength, size the bearings for adequate life and fix the input and output coupling means. Calculations showing the adequacy of the design are presented in the Appendix.

It is the recommendation of the Continental Motors Corporation that cantilever mounting of the pumps and splitter drive on the engine be avoided to avoid failures of the engine inlet housing. Since it therefore becomes necessary to support the pumps, advantage of this is taken in the design of the splitter drive in the form of thinner wall sections than would be possible with a cantilever mounting arrangement.

## 5. Final Drives

Of prime consideration in the design of the final drive is that they be adequate to handle the torque required to provide the 48,600 in-lbs wheel torque the concept and feasibility study indicated was necessary to cope with extremes in terrain.

In addition, the final drive must not materially affect ground clearance, must permit installation with minimum rework of the weapon and must contain a clutch or other means of dis-engaging the drive so the weapon can be towed. The final drives must also permit mounting the motors and hydraulic lines with a minimum of rework to the weapon and so as not to interfere with the firing of the weapon in any of its normal extreme positions.

The 105mm Howitzer has band type parking brakes in the most desirable location for the final drive. Removing these parking brakes means that this function must be provided, either by relocating band type brakes or by building the function into the final drives. The latter proved simplest and provided a substantial weight savings.

It is possible to change from the towing mode to the parking brake mode or the auxiliary propelled mode through the use of a single sliding splined shaft. This is shown in the assembly drawing of the final drive presented later in this report.

Calculations are presented in the Appendix that show teeth loading (both Lewis and Hertz stresses), bearing loads and life and spline loads. Gear loads, bearing loads and bearing lives are shown for maximum torque conditions and for maximum speed conditions at three horsepower levels.

Prediction of bearing life is difficult because, (1) the loads applied to the drives vary over a considerable range, (2) no two weapons will be subjected to the same operating conditions and (3) the basic variation in life of a given bearing size. It is expected that the lives of the bearings used will be more than adequate for the application.

The final drive design permits removal of the wheel for wheel bearing inspection in the conventional automotive manner. Removal of the cotter key and the spindle nut allows the wheel to be removed along with the final gear of the drive. Care is of course necessary in removal and replacement to avoid damage to the wheel bearing seal as well as the final drive seal.

Inspection and removal of all the gears and bearings is possible without removing the final drive housings from the weapon. The hydraulic motors may be removed for servicing without removal of the final drives.

## 6. Hydraulic Lines and Fittings

System requirements of flow and pressure dictate that the main circuit hydraulic lines be 1" I.D. to keep flow losses to a minimum and capable of withstanding a maximum working pressure of 3000 psi. Rigid tubing is lighter and more durable than flexible hose; it would, therefore, be desirable to use rigid tubing throughout. The use of some flexible hose is necessary, however, to permit splitting of the trails and to help take up vibrations.

Rigid steel tubing of 1.25 O.D. and .120 wall thickness provides an inside diameter of one inch and a bursting pressure of 10,500 psi. This line size provides area sufficient to keep the maximum line velocity below 15 fps and the maximum HP loss to less than 1 HP. The tube weighs 1.45 lbs/ft.

The flexible hose selected for use is Anchor Coupling's 16CHX which is a 3 ply braided hose which has a maximum recommended working pressure of 3000 psi and a 12,000 psi burst pressure. It weighs 1.6 lbs/ft. Flange type couplings are used on these large lines.

Steel tubing and Imperial Hi-Seal type fittings are used on the remaining lines. These fittings do not require flaring and are capable of withstanding considerably higher pressures than they will encounter.

Considerable savings in weight could be realized by using stainless steel tubing throughout due to the thinner walls required to carry a given pressure. The tubing cost would be about three times as much as for steel tubing.

#### 7. Reservoir

The reservoir used is of special design to fit between the trails under the pumps. Its capacity is 4.0 gallons. A breather cap is provided to avoid contamination of the oil by blown-in dust. A charge pump suction line filter is provided within the reservoir.

#### 8. Pivot Wheel and Bracket

The pivot wheel used is the Saginaw Products Corporation number 14181. This is the same pivot wheel that is used on the original auxiliary propelled 155mm Howitzer. Two were used in that application. Some difficulties were encountered in that application, however, it is felt that most were caused by terrain conditions causing one pivot wheel to support the entire load thus overloading it. This resulted in bending of the pivot wheel swivel and of the cantilever shaft used to support the pivot wheel assembly. On a production basis the pivot wheel can be strengthened, the wheel bearing seals improved, and the fork redesigned to give greater clearance for accumulated mud.

The bracket used to support the pivot wheel is designed to support both ends of the shaft, thus eliminating the cantilever effect. It is provided with a means of swinging the wheel assembly up out of the way for towing and firing.

Other commercial sources were investigated but none could be located that offered a pivot wheel suitable for this application.

9. Trail Jack

The trail jack, manufactured by Ryerson & Haynes, Inc., Jackson, Michigan, provided to raise and lower the trails in changing operating modes is a conventional automotive type bumper jack with a special bracket bolted directly to the trail. One is furnished. It is intended to modify the handspike so it can serve as the jack handle.

The jack has a capacity of 1800 lbs. and a stroke of 42" although the latter can be varied easily by replacing the jack column. The jack column may be quickly moved to the point at which load is applied and once the load is removed it may be quickly moved to its fully retracted position.

10. Seat

A stamped aluminum seat of the type used on agricultural implements was selected on the basis of light weight, availability and low cost. The seat, manufactured by the Milsco Manufacturing Co., offers somewhat greater side stability for the operator and has a higher rear rim than does the relatively flat pan seat used on the original auxiliary propelled 155mm Howitzer. It weighs approximately 3.5 lbs.

A second type seat will be put on one weapon for a trial. This seat is of welded tube construction with a back rest and padded seat. It is available with arm rests although they probably would interfere with side arms and other equipment carried at the belt. This seat is slightly heavier than the aluminum one but appears to offer greater operator comfort. If the trial shows the seat warrants further consideration it will be left on the weapon when it is shipped.

11. Foot Rest

A fabricated aluminum foot rest is provided that can also serve as a floatation pad for the trail jack in soft terrain. The foot rest is fabricated of aluminum plate and has a slip resistant pattern on the top surface.

E. DRAWINGS

Reduced size prints of the following drawings are included in this report.

<u>Drawing</u>	<u>Title</u>	<u>Pages</u>
4000105	Auxiliary Propulsion Installation	17,18
4000115	Splitter Drive Assembly	19
4000128	Final Drive Assembly (R.H.)	20

A complete set of drawings has been supplied to Rock Island Arsenal in accordance with the requirements of the contract. The contract required that these drawings be in accordance with Rock Island Arsenal's Research and Development Drawing Manual and subject to the provisions of the data article of Title II of the contract (ASPR 9-203.1 and 9-203.4).

F. CONCLUSIONS

The design and detailing of an auxiliary propulsion system for the 105mm Howitzer has been completed. No insurmountable design problems were encountered.

G. RECOMMENDATIONS

It is recommended that one or more 105mm Howitzers be equipped with the auxiliary propulsion system designed in this phase of the contract for test and evaluation purposes.

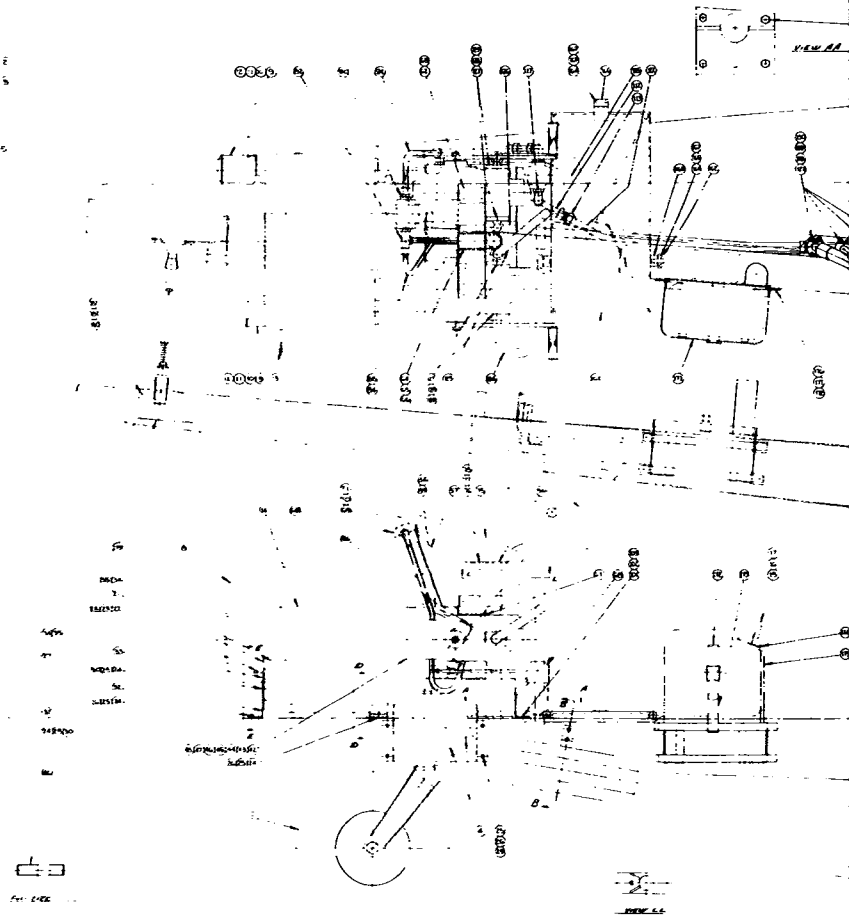
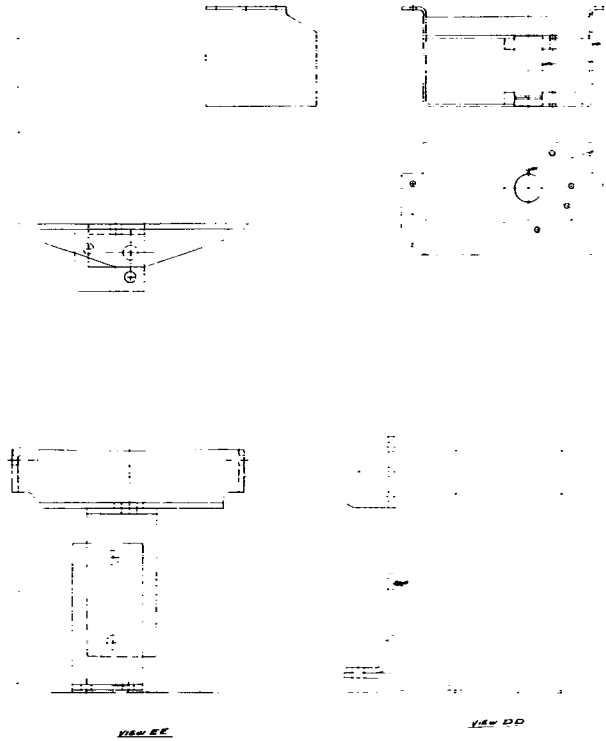

1



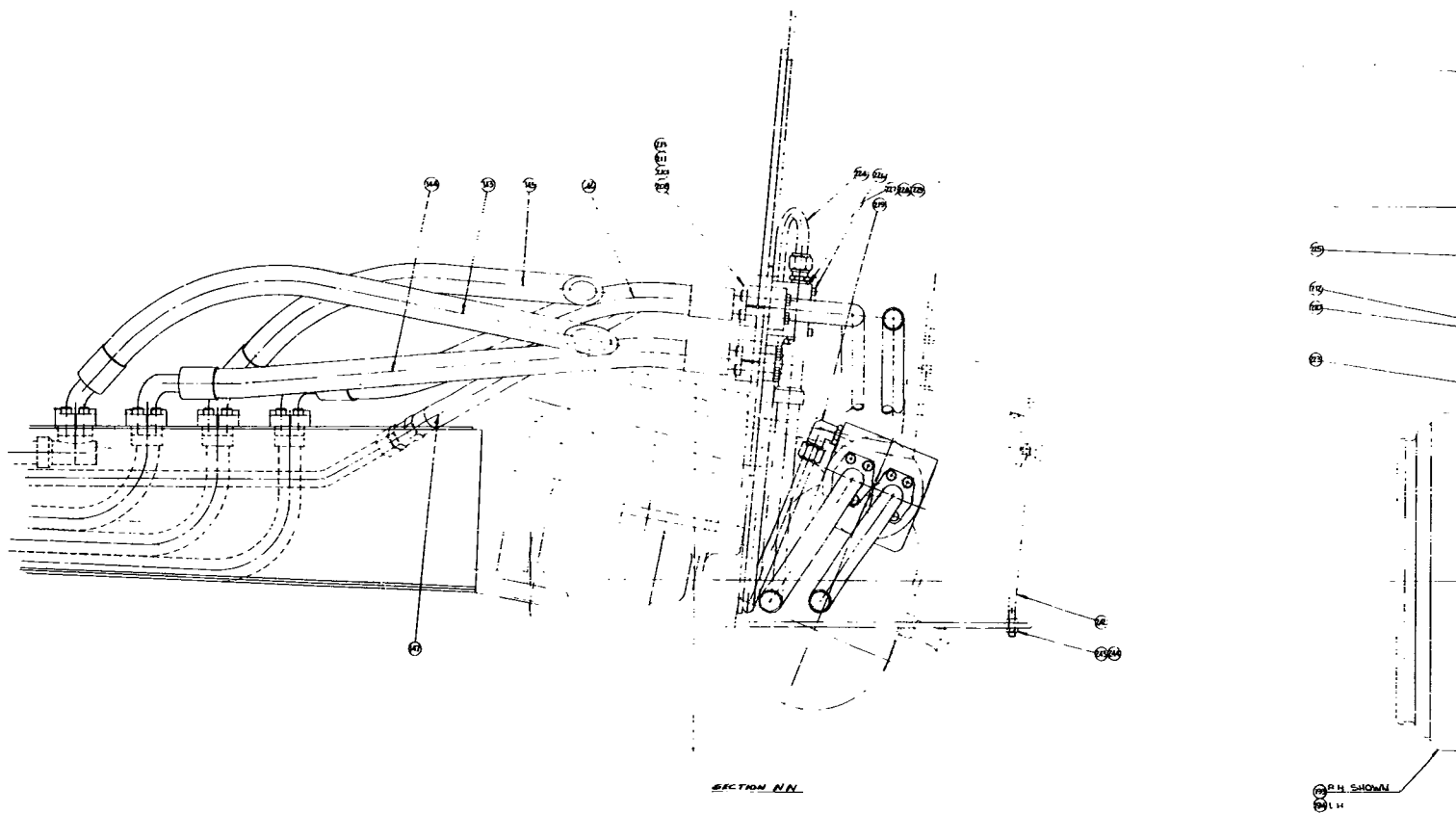

**1**

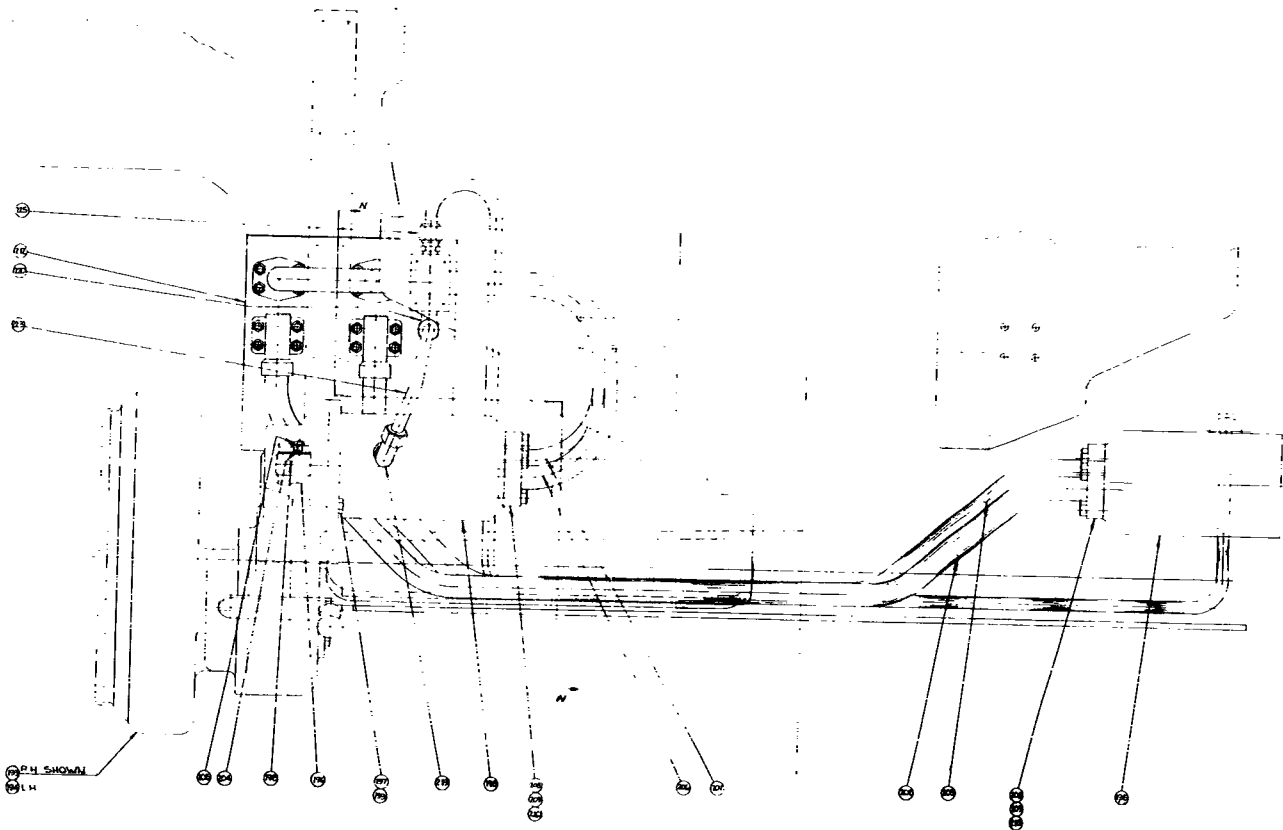

2

SUNDBRAND AVIATION	
AUXILIARY PROPULSION SYSTEM INSTALLATION	
Part No.	4000105
Rev.	J
Date	9/16/7
Drawn by	
Checked by	
Approved by	
Part No.	4000105
Rev.	J
Date	9/16/7
Drawn by	
Checked by	
Approved by	

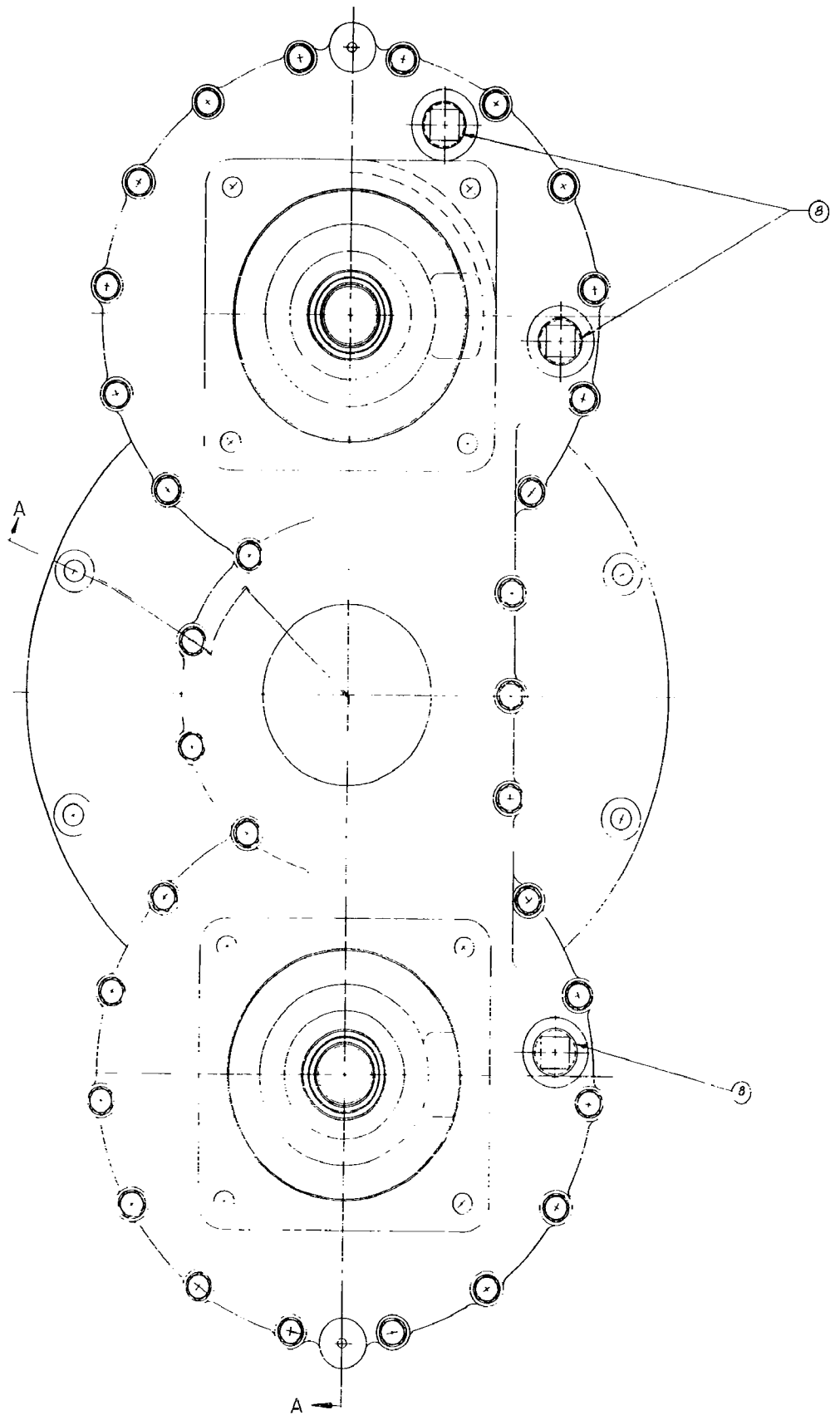

1



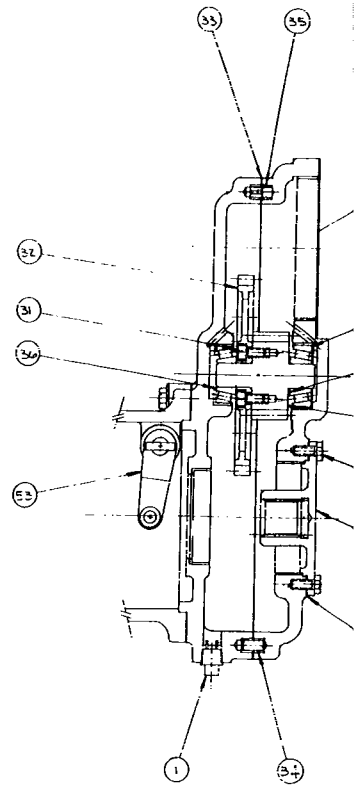
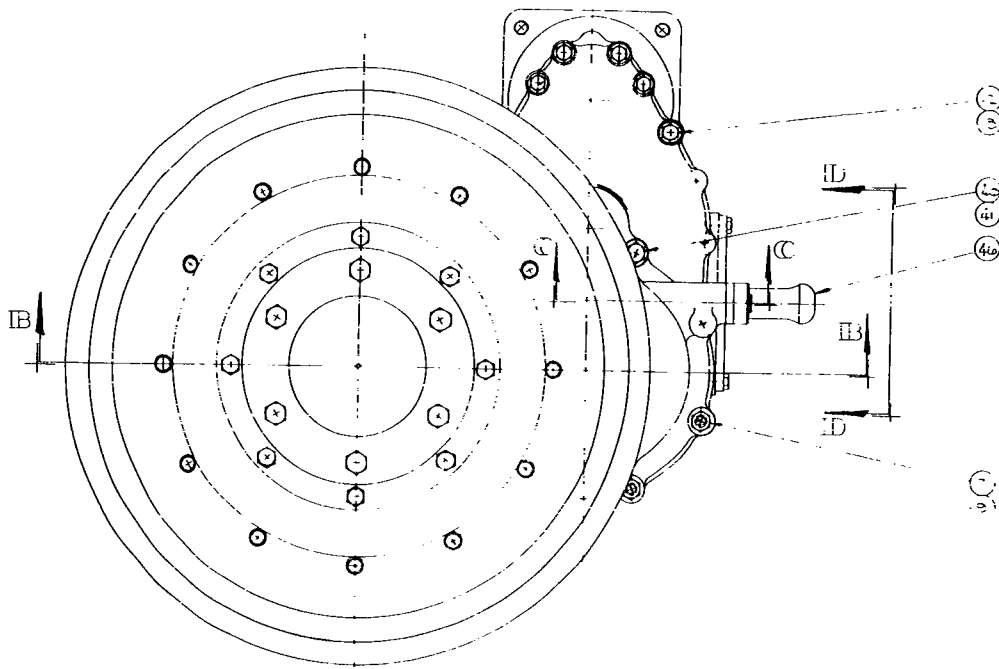

SECTION I-A-I A

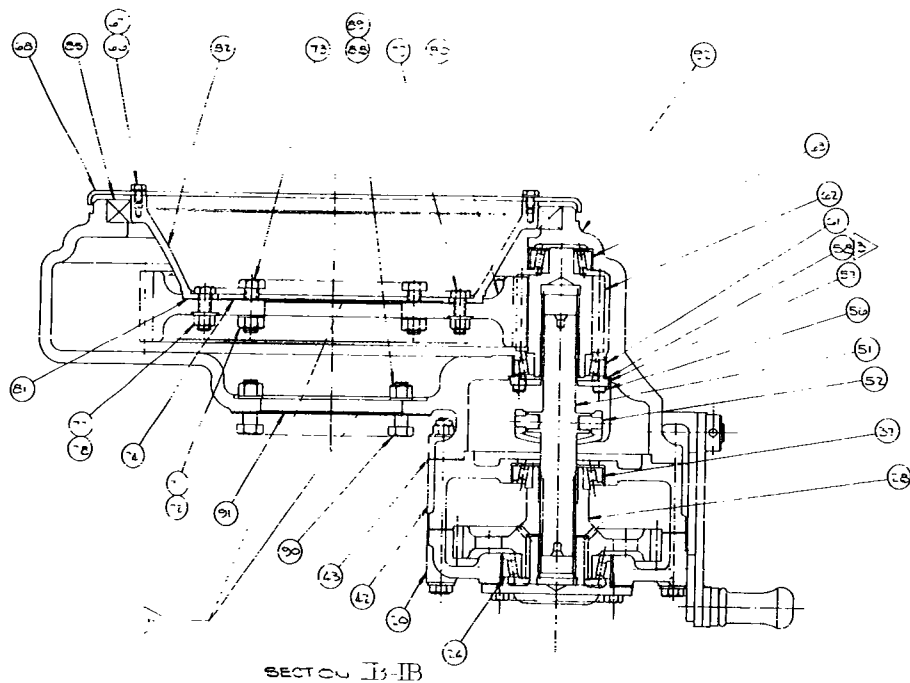

SECTION I-B-I B

**1**



## APPENDIX

## INDEX TO THE APPENDIX

	<u>Page</u>
General Considerations	23
Final Drive Gear and Bearing Calculations	26
Final Drive Spline Calculations	35
Splitter Drive Gear and Bearing Calculations	38
Splitter Drive Spline Calculations	41

# 105mm Howitzer System Based On 3.2 Units

## GENERAL CONSIDERATIONS

1. Engine: 2A042 Military Standard Engine  
17.6 Max. HP Output  
10.0 Cont. HP Output
2. Pumps: 3.2 In<sup>3</sup>/Rev. Variable Displacement  
Axial Piston Type Max. RPM = 2500
3. Motors: 3.2 In<sup>3</sup>/Rev. Fixed Displacement  
Axial Piston Type Max. RPM = 2400
4. Splitter Drive:  $\frac{2500}{4000} = 0.625 \frac{\text{Output}}{\text{Input}}$
5. Hydraulic Line Size And Flow: Oil Flow =  $\frac{3.2 \text{ In}^3/\text{Rev.} \times 2500 \text{ RPM}}{23.1 \text{ In}^3/\text{Gal.}} = 34.7 \text{ GPM}$

A 1" I.D. Hydraulic Line is required to keep the maximum line velocity to about 15 FPS.

6. Hydraulic Line Loss: From "Fluid Flow" a Crane Co. Publication,

$$\Delta P_{100} = 0.0215 \frac{f \rho Q^2}{d^5}$$

f = Friction Factor  $\cong$  0.035

$\rho$  = Oil Density  $\cong$  53 Lbs/FT<sup>3</sup>

Q = Oil Flow = 34.7 GPM

d = Line Size = 1.0 Inches

$\Delta P_{100}$  = Pressure Drop, PSI/100 Ft.

Assume an equivalent length of 100 ft. to compensate for fittings and bends.

$$\Delta P_{100} = 0.0215 \times \frac{0.035 \times 53 \times 34.7^2}{(1.0)^5}$$

$\Delta P_{100} = 48 \text{ PSI/100 Feet at maximum speed}$

GENERAL CONSIDERATIONS

6. (Cont.)

$$\begin{aligned} \text{HP Loss} &= \frac{\Delta P \times 6PM}{1715} \\ &= \frac{48 \times 34.7}{1715} \end{aligned}$$

HP Loss = 0.97 HP at maximum speed

$$\begin{aligned} \Delta P \text{ at Motor} &= 3000 - 120 - 50 = 2830 \text{ PSI,} \\ &\text{say } 2800 \text{ PSI at maximum} \\ &\text{speed} \end{aligned}$$

$$= 3000 - 120 = 2880 \text{ PSI at stall.}$$

7. Motor  
Torque:

Theoretical ~

$$\begin{aligned} T_{TH} &= \frac{\Delta P \times \text{Displacement}}{2} \\ &= \frac{2880 \times 3.2}{2} \end{aligned}$$

$$T_{TH} = 1470 \text{ In-Lbs}$$

Actual ~

$$\begin{aligned} T_a &= T_{TH} \times \text{Torque Efficiency} \\ &= 1470 \times .92 \\ T_a &= 1360 \text{ In-Lbs} \end{aligned}$$

8. Final  
Drive  
Ratio:

It was determined in the study contract that  
48,600 In-Lbs Wheel Torque is required:

$$\frac{48,600}{1360 \times .975} = 36.7:1 \text{ Ratio Required}$$

9. Top  
Vehicle  
Speed:

Rolling Radius of a 9.00 - 20 Tire is 19.2 Inches

$$\frac{5280}{2\pi \times \frac{19.2}{12}} = 525 \text{ Revolutions/Mile}$$

$$\frac{525}{60} = 8.75 \text{ RPM/MPH}$$

$$8.75 \times 36.7 = 321 \text{ Motor RPM/MPH}$$

$$\frac{2400 \text{ RPM (Motor Max.)}}{321} = 7.5 \text{ MPH}$$

105mm Howitzer System Based On 3.2 Units

GENERAL CONSIDERATIONS

10. Vehicle Range:  $\frac{.75 \text{ Lbs/BHP} \times 17.6 \text{ HP}}{6.6 \text{ Lbs/Gal}} = 2 \text{ GPH Fuel Consumption -- Max.}$

2.5 Hours Operation with a 5 Gallon Fuel Tank

$2.5 \times 7.5 = 18.75 \text{ Miles} = \text{Maximum Range at Maximum HP Output}$

105mm Howitzer Final Drive

GEAR CALCULATIONS

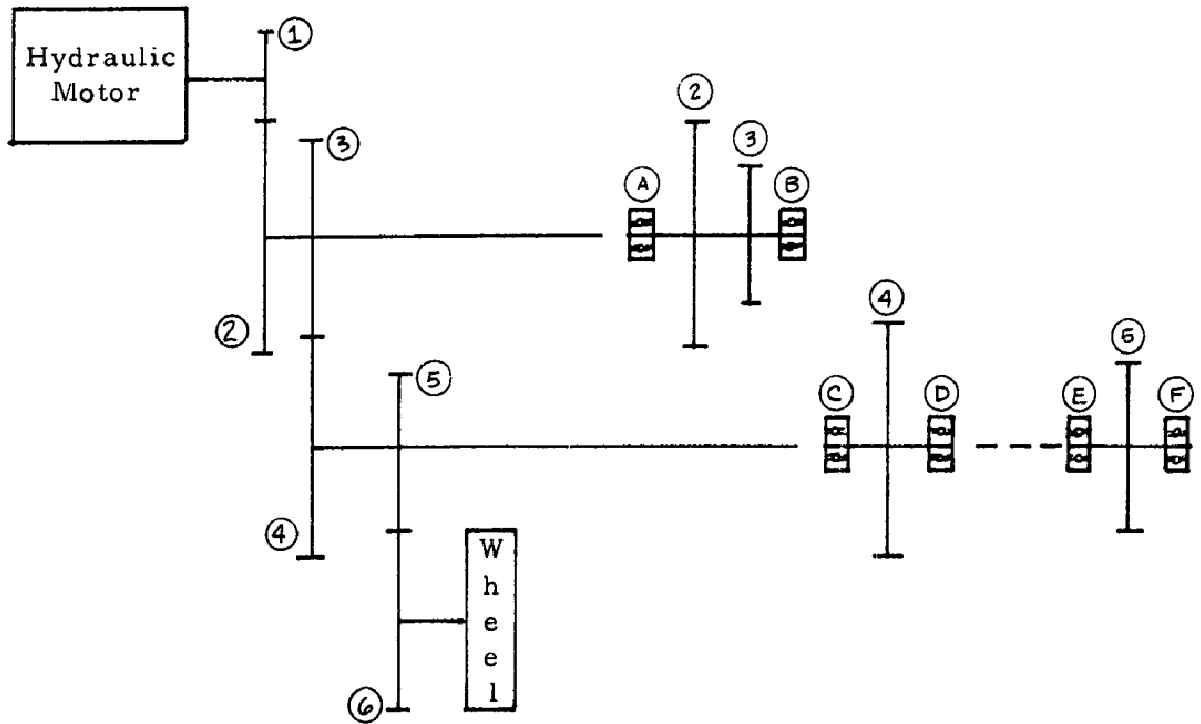

Gear Number	Pitch Diameter	Ratio	Diametral Pitch	Number of Teeth	Face Width
1	2.0	3	8	16	.5
2	6.0			48	
3	2.5	2.55	8	20	1.0
4	6.375			51	
5	2.5	4.8	6	15	2.19
6	12			72	

105mm Howitzer Final Drive

GEAR CALCULATIONS

Maximum Torque Conditions

Gear Number	Maximum Torque	RPM At ——— HP Input			Lewis Stress	Hertz Stress
		28	14	7		
1	1350	1310	655	327	70,000	223,000
2	4050	436	218	109	44,300	223,000
3					73,500	223,000
4	10,350	170	85	42.5	52,500	223,000
5					76,500	224,000
6	49,500	35.8	17.8	8.9	43,400	224,000

Bearing Letter	Catalog <sup>③</sup> Number	Load	Catalog <sup>②</sup> Rating	Life at Max. Torque <sup>③</sup>		
				28 HP In	14 HP In	7 HP In
A	LM11910/ LM11949	2395	3880	200	390	770
B	09195/09067	2340	5020	500	970	1920
C	L507910/ L507949	2390	8460	6,400	12,800	25,600
D	18520/18590	1225	6040	20,000	40,000	80,000
E	18520/18590	4790	6040	210	420	840
F	09195/09067	4350	5020	155	310	620

① Timken & SKF (Tyson)

② "Basic Dynamic Load Rating" - The load that will result in a B-10 life of 1,000,000 revolutions. 90% of the bearings will last longer.

③ B-10 Life.

105mm Howitzer Final Drive

GEAR CALCULATIONS

Maximum Speed Conditions

Gear Number	Maximum Speed	HP Input	Lewis Stress	Hertz Stress
1	2400	28	38,200	164,300
		14	19,100	116,000
		7	9,550	82,000
2	800	28	24,100	164,300
		14	12,050	116,000
		7	6,040	82,000
3	800	28	39,900	164,700
		14	20,000	116,000
		7	10,000	82,200
4	314	28	28,600	164,700
		14	14,300	116,000
		7	7,200	82,200
5	314	28	41,500	165,00
		14	20,750	116,500
		7	10,400	82,500
6	65	28	23,450	165,000
		14	11,700	116,500
		7	5,850	82,500

## 105mm Howitzer Final Drive

GEAR CALCULATIONSMaximum Speed Conditions

Brg.	Catalog Number	Max. Torque Loads		HP Input	Max. Speed Loads		Catalog Rating C Lbs	C/P	RPM	Brg Life Hrs.
		Gear In-Lbs	Bearing Lbs		Gear In-Lbs	Bearing (P) Lbs				
A	LM11910 - LM11949	4050	2395	28	2200	1300	3880	2.98	800	830
				14	1100	650				8,000
				7	550	325				77,000
B	09195 - 09067	4050	2340	28	2200	1270	5020	3.95	800	2,000
				14	1100	635				20,000
				7	550	320				200,000
C	L507910 - L507949	10,350	2390	28	5610	1295	8460	6.50	314	29,000
				14	2800	650				260,000
				7	1400	325				∞
D	18520 - 18590	10,350	1225	28	5610	665	6040	9.07	314	83,000
				14	2800	333				∞
				7	1400	167				∞
E	18520 - 18590	10,350	4790	28	5610	2600	6040	2.32	314	900
				14	2800	1300				9,000
				7	1400	650				90,000
F	09195 - 09067	10,350	4350	28	5610	2340	5020	2.15	314	700
				14	2800	1170				7,000
				7	1400	585				70,000

105mm Howitzer Final Drive

GEAR CALCULATIONS

Maximum Torque Conditions

Gear 1

$$\frac{1350}{1.0} = 1350 \text{ Lbs Tangential Load}$$

$$1350 \text{ Tan } 25^\circ = 630 \text{ Lbs Radial Load}$$

$$\text{Lewis Stress} = \frac{1350 \times 8}{.5 \times .308} = 70,100 \text{ PSI}$$

$$\text{Hertz Stress} = 3240 \sqrt{\frac{1350 (1/2 + 1/6)}{.5 \times .381}} = 223,000 \text{ PSI}$$

Gear 2

$$1350 \text{ Lbs Tangential Load}$$

$$630 \text{ Lbs Radial Load}$$

$$\text{Lewis Stress} = \frac{1350 \times 8}{.5 \times .487} = 44,300 \text{ PSI}$$

$$\text{Hertz Stress} = 223,000 \text{ PSI}$$

Gear 3

$$\frac{4050}{1.25} = 3240 \text{ Lbs Tangential Load}$$

$$3240 \text{ Tan } 25^\circ = 1510 \text{ Lbs Radial Load}$$

$$\text{Lewis Stress} = \frac{3240 \times 8}{1 \times .353} = 73,500 \text{ PSI}$$

$$\text{Hertz Stress} = 3240 \sqrt{\frac{3240 (1/2.5 + 1/6.375)}{1.0 \times .381}} = 223,000 \text{ PSI}$$

105mm Howitzer Final Drive

GEAR CALCULATIONS

Gear 4

3240 Lbs Tangential Load

1510 Lbs Radial Load

$$\text{Lewis Stress} = \frac{3240 \times 8}{1 \times .493} = 52,500 \text{ PSI}$$

Hertz Stress = 223,000 PSI

Gear 5

$$\frac{10,350}{1.25} = 8280 \text{ Lbs Tangential Load}$$

8280 Tan 25° = 3860 Lbs Radial Load

$$\text{Lewis Stress} = \frac{8280 \times 6}{2.19 \times .257} = 76,500 \text{ PSI}$$

$$\text{Hertz Stress} = 3240 \sqrt{\frac{8280(1/2.5 \times 1/12)}{2.19 \times .381}} = 224,000 \text{ PSI}$$

Gear 6

8280 Lbs Tangential Load

3860 Lbs Radial Load

$$\text{Lewis Stress} = \frac{8280 \times 6}{2.19 \times .522} = 43,400 \text{ PSI}$$

Hertz Stress = 224,000 PSI

BEARING LOADS & LIFE

Maximum Torque Conditions

Bearings A & B

$$\sum M_{xB} = 0$$

$$1510 \times .9 - 630 \times 1.74 - 2.21 A_x = 0$$

$$1360 - 1095 - 2.21 A_x = 0$$

$$A_x = \frac{265}{2.21}$$

$$\underline{A_x = 120\#}$$

$$\sum M_{yB} = 0$$

$$3240 \times .9 + 1350 \times 1.74 - 2.21 A_y = 0$$

$$2920 + 2350 - 2.21 A_y = 0$$

$$A_y = \frac{5270}{2.21}$$

$$\underline{A_y = 2390\#}$$

$$A = \sqrt{2390^2 + 120^2}$$

$$\underline{A = 2395 \text{ Lbs}}$$

$$\sum M_{xA} = 0$$

$$630 \times .47 - 1510 \times 1.31 + 2.21 B_x = 0$$

$$296 - 1980 + 2.21 B_x = 0$$

$$B_x = \frac{1684}{2.21}$$

$$\underline{B_x = 760\#}$$

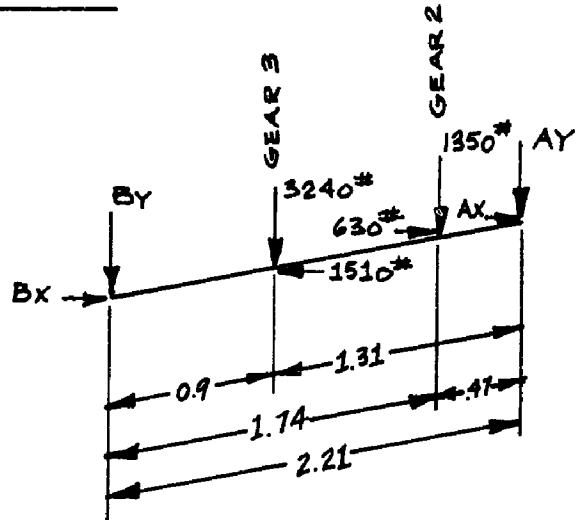

# 105mm Howitzer Final Drive

## BEARING LOADS & LIFE

$$\sum M_{yA} = 0$$

$$1350 \times .47 + 3240 \times 1.31 + 2.21 B_y = 0$$

$$635 + 4250 + 2.21 B_y = 0$$

$$B_y = - \frac{4885}{2.21}$$

$$B_y = - 2210 \#$$

$$B = 2210 + 760$$

$$\underline{\underline{B = 2340 \text{ Lbs}}}$$

Bearing	RPM	Load (P) Lbs	Basic Dynamic Load Rating (C) Lbs	C/P	B-10 Life Hrs
A	436				200
A	218	2395	3880	1.62	390
A	109				770
B	436				500
B	218	2340	5020	2.14	970
B	109				1920

### Bearings C & D

$$D_x = \frac{0.79}{2.31} \times 1510 \# = 516 \text{ Lbs}$$

$$D_y = \frac{0.79}{2.31} \times 3240 \# = 1110 \text{ Lbs}$$

$$D = \sqrt{1110^2 + 516^2} = 1225 \text{ Lbs}$$

$$C_x = \frac{1.52}{2.31} \times 1510 \# = 994 \text{ Lbs}$$

$$C_y = \frac{1.52}{2.31} \times 3240 \# = 2130 \text{ Lbs}$$

$$C = \sqrt{2130^2 + 994^2} = 2390 \text{ Lbs}$$

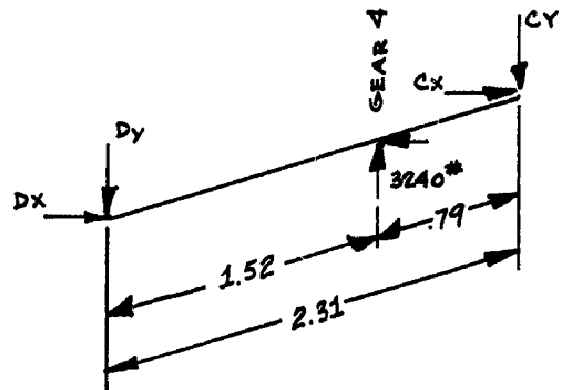

105mm Howitzer Final Drive

BEARING LOADS & LIFE

Maximum Torque Conditions

Bearing	RPM	Load (P) Lbs	Basic Dynamic Load Rating (C) Lbs	C/P	B-10 Life Hrs
C	170	2390	8460	3.54	6,400
C	85				12,800
C	42.5				25,600
D	170	1225	6040	4.93	20,000
D	85				40,000
D	42.5				80,000

Bearings E & F

$$E_x = \frac{1.53}{2.92} \times 3860 \# = 2020 \text{ Lbs}$$

$$E_y = \frac{1.53}{2.92} \times 8280 \# = 4340 \text{ Lbs}$$

$$E = \sqrt{4340^2 + 2020^2} = 4790 \text{ Lbs}$$

$$F_x = \frac{1.39}{2.92} \times 3860 \# = 1840 \text{ Lbs}$$

$$F_y = \frac{1.39}{2.92} \times 8280 \# = 3940 \text{ Lbs}$$

$$F = \sqrt{3940^2 + 1840^2} = 4350 \text{ Lbs}$$

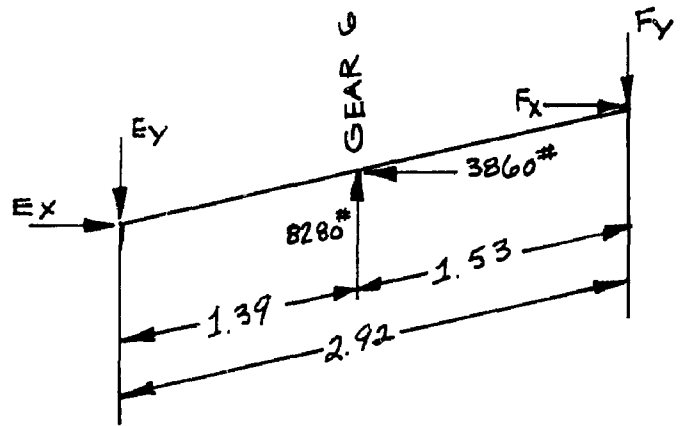

Bearing	RPM	Load (P) Lbs	Basic Dynamic Load Rating (C) Lbs	C/P	B-10 Life Hrs
E	35.8	4790	6040	1.26	210
E	17.8				420
E	8.9				840
F	35.8	4350	5020	1.153	155
F	17.8				310
F	8.9				620

SPLINE CALCULATIONS

10,350 In-Lbs Torque is the maximum that must be transmitted.

Shaft Stress

$$S_s' \geq S_s \frac{K_a}{L_f}$$

$$L_f = 0.8$$

$$K_a = 1.3$$

$$S_s' = 50,000 \text{ PSI for case hardened steel}$$

$$S_s \leq 50,000 \times \frac{0.8}{1.3} \leq 30,800$$

$$D_{rc}^3 = \frac{S_s \pi}{16 \pi}$$

$$= \frac{30,800 \pi}{10,350 \times 16}$$

$$= .585 \text{ In}$$

$$D_{rc} = .765 \text{ In} \quad \text{Use } 1.0 \text{ In.}$$

Tooth Stress - Shear

$$S_s = \frac{4TK_m}{DNF_{etc}}$$

$$= \frac{4 \times 10,350 \times 1.5}{1.063 \times 17 \times 1 \times .095}$$

$$S_s = 36,200 \text{ PSI}$$

Slightly high but will use anyway since  $K_m$  could be slightly lower.

These calculations have been based on a 17 tooth 16/32 Spline.

105mm Howitzer Final Drive

SPLINE CALCULATIONS

Tooth Stress - Compressive

$$S_c = \frac{2TK_m}{DNEwh}$$

$$= \frac{2 \times 10,350 \times 1.5}{1.063 \times 17 \times 1 \times .1}$$

$$S = 17,200 \text{ PSI}$$

$$K_a = 1.3$$

$$L_w = 2.0 \text{ for } 1 \times 10^6 \text{ Revolutions } 170 \text{ RPM} \times 60 \times 500 = 5,100,000 \text{ Revolutions}$$

Use  $1 \times 10^6$  because unit will not be operating at max. torque and max. (170) RPM at all times.

$$S_c \geq S_c \frac{K_a}{L_w} \geq 17,200 \frac{1.3}{2.0} = 11,200 \text{ PSI}$$

A crowned spline is required.

Bursting Stresses

I. Radial Force Component at the Pitch Line

$$S_1 = \frac{T \tan \phi}{\pi D t w F}$$

$$= \frac{10,350 \tan 30^\circ}{\pi \times 1.063 \times .225 \times 1.}$$

1.625
<u>1.175</u>
2 <u>1.450</u>
.225

$$S_1 = 4,480 \text{ PSI}$$

II. Centrifugal Force

$$S_2 = 0.828 \times 10^{-6} \times n^2 (2D_{oi}^2 + 0.424 D_{rt}^2)$$

$$= 0.828 \times 10^{-6} \times (336)^2 (2 \times 1.625^2 + 0.424 \times 1.175^2)$$

$$= 0.0934 (5.3 + .59)$$

$$S_2 = 0.55 \text{ PSI}$$

SPLINE CALCULATIONS

## III. Beam Loading of the Teeth

$$S_3 = \frac{4T}{D^3 F_e Y}$$

$$= \frac{4 \times 10,350}{(1.063)^3 \times 1 \times 1.5}$$

$$S_3 = 24,400 \text{ PSI}$$

## IV. Total Stress

$$S_T = K_a K_m (S_1 + S_3) + S_2$$

$$= 1.3 \times 1.5 (28,880)$$

$$S_T = 56,400 \text{ PSI}$$

$$S_T' = 55,000 \text{ PSI} \quad \text{Allowable}$$

Crowning

$$r_1 = 0.90 \frac{D}{2} \tan \phi$$

$$= 0.45 \times 1.063 \tan 30^\circ$$

$$r_1 = .155$$

$$r_2 = r_1 / \tan \phi$$

$$= .155 / \tan 30^\circ$$

$$r_2 = .478$$

105mm Howitzer Splitter Drive

BEARING & GEAR CALCULATIONS

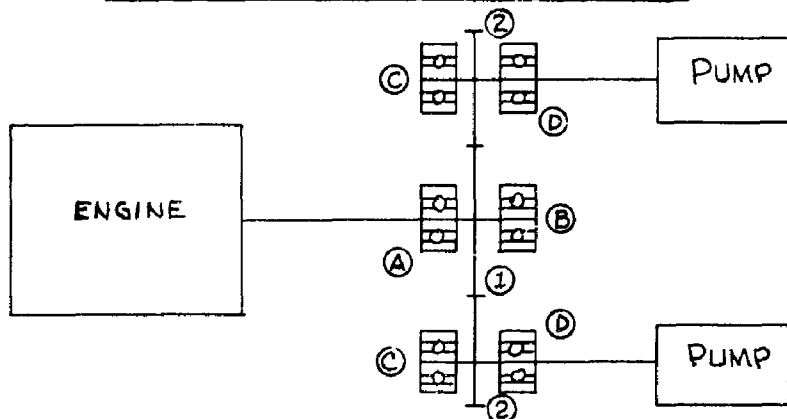

Gear Number	Fitch Diameter	Ratio	Diametral Pitch	Number of Teeth	Face Width
1	5.1667	1.6	12	62	.25
2	8.25		12	99	.25

Gear Number	RPM	HP	Torque In-Lb	Lewis Stress <sub>psi</sub>	Hertz Stress <sub>psi</sub>
1	4000 Max.	35	551	24,200	296,000
		28	431	18,900	262,000
		21	331	14,500	230,000
		14	221	9,670	187,300
		7	110	4,820	132,000
2	2500 Max.	28	705	17,900	262,000
		21	530	13,700	230,000
		14	353	9,150	187,300
		7	177	4,560	132,000

Bearing Letter	Catalog Number	Load @ 35 HP (Lbs)	Catalog <sup>①</sup> Rating (Lbs)	RPM	B-10 Life (Hrs.)
A	SKF 6908	93	2370	4000	72,500
B	SKF 6908	135	2370	4000	110,000
C	SKF 6908	93	2370	2500	23,000
D	SKF 6908	135	2370	2500	37,000

① Basic Dynamic Load Rating

105mm Howitzer Splitter Drive

BEARING & GEAR CALCULATIONS

$$\frac{C}{P} = \frac{2370}{93} = 25.5 \text{ (Brgs. A \& C)}$$

B-10 Life at 4000 RPM = 72,500 Hours - Bearing A  
at 2500 RPM = 110,000 Hours - Bearing C

$$\frac{C}{P} = \frac{2370}{135} = 17.6 \text{ (Brgs. B \& D)}$$

B-10 Life at 4000 RPM = 23,000 Hours - Bearing B  
at 2500 RPM = 37,000 Hours - Bearing D

# 105mm Howitzer Splitter Drive

## BEARING & GEAR CALCULATIONS

### Gear 1

$$\text{Lewis Stress} = \frac{2 \times \text{Torque} \times 12}{5.1667 \times .423 \times .25} = \begin{array}{l} 24,200 \text{ PSI at 35 HF} \\ 18,900 \text{ PSI at 28 HP} \\ 14,500 \text{ PSI at 21 HP} \\ 9,670 \text{ PSI at 14 HP} \\ 4,820 \text{ PSI at 7 HP} \end{array}$$

$$\begin{aligned} \text{Hertz Stress} &= 3240 \sqrt{\frac{2 \times \text{Torque}}{5.1667} \left( \frac{1}{5.1667 \times .25} + \frac{1}{8.25 \times .321} \right)} \\ &= 3240 \sqrt{15.12 \times \text{Torque}} \\ &= 12,600 \sqrt{\text{Torque}} = \begin{array}{l} 296,000 \text{ PSI at 35 HP} \\ 262,000 \text{ PSI at 28 HP} \\ 230,000 \text{ PSI at 21 HP} \\ 187,300 \text{ PSI at 14 HP} \\ 132,000 \text{ PSI at 7 HP} \end{array} \end{aligned}$$

### Gear 2

$$\text{Lewis Stress} = \frac{2 \times \text{Torque} \times 12}{8.25 \times .25 \times .448} = \begin{array}{l} 17,900 \text{ PSI at 28 HP} \\ 13,700 \text{ PSI at 21 HP} \\ 9,150 \text{ PSI at 14 HP} \\ 4,560 \text{ PSI at 7 HP} \end{array}$$

### Bearings A & B (and C & D)

35 HP Input - 35 HP Output to One Pump

$$\frac{551 \text{ In-Lbs}}{2} = 214\# \text{ Tangential Load}$$

$$\frac{214}{20^\circ} = 228 \text{ Lbs.}$$

$$A = \frac{.40}{.98} \times 228 = 93 \text{ Lbs}$$

$$B = \frac{.58}{.98} \times 228 = 135 \text{ Lbs}$$

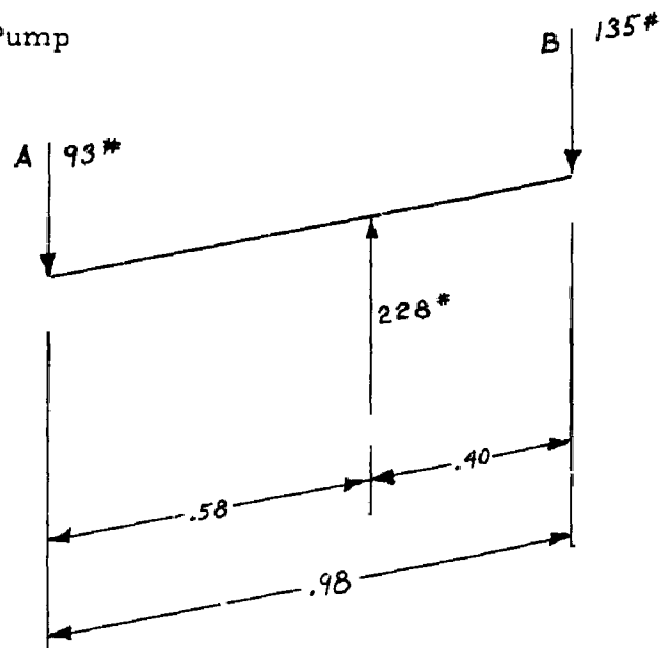

# 105mm Howitzer Splitter Drive

## SPLINE CALCULATIONS

Calculations are based on "When Splines Need Stress Control"

By D. W. Dudley, Product Engineering - December 23, 1957

### Input Spline

17 Teeth, 16/32 Pitch, 1.062 Pitch Dia., .562 Long

### Shear Stresses in Teeth

$$S_s = \frac{4TK_m}{DNF_e t_c}$$
$$= \frac{4 \times 551 (35\text{HP}) \times 2 \times 17 \times 1}{1.062 \times 17 \times .562 \times 1.062}$$

$$S_s = 6960 \text{ PSI}$$

Application Factor = 2.2

$$S_s = 15,300 \text{ PSI}$$

Maximum Allowable  $S_s$  is 50,000 PSI

### Compressive Stresses in Teeth

$$S_c = \frac{2TK_m}{DNF_e h}$$
$$= \frac{2 \times 551 \times 1}{1.062 \times 17 \times .562 \times .062}$$

$$= 1750 \text{ PSI}$$

Application Factor ( $K_A$ ) = 2.2

Wear Life Factor ( $L_W$ ) = 1.4

$$S_c = 1750 \times \frac{2.2}{1.4}$$

$$S_c = 2750 \text{ PSI}$$

Maximum Allowable  $S_c$  is 4000 PSI

$T$  = Torque, In-Lbs

$K_m$  = Load Distribution Factor

$D$  = Pitch Diameter, Inches

$F_e$  = Effective Face Width, In.

$t_c$  = Chordal Thickness at  
Pitch Line, In. ( $\approx 0/2N$ )

$N$  = Number of Teeth

$h$  = Radial Height of the  
Tooth in Contact, In.

$d_o$  = Shaft Diameter, In.

$M$  = Shaft Bending Moment,  
In. Lbs.

$K_A$  = Application Factor

$L_W$  = Weak Life Factor

$L_f$  = Fatigue Life Factor

$\phi$  = Pressure Angle

$t_w$  = Wall Thickness, In.

$n$  = RPM

$D_{oi}$  = Outside Diameter of an  
Internally Splined Part

$D_{ri}$  = Major Diameter of an  
Internally Splined Part

$Y$  = Factor (same as Y-Factor  
used in the Lewis Equation  
for Gears)

# 105mm Howitzer Splitter Drive

## SPLINE CALCULATIONS

### Shaft Stresses

$$S_{s \text{ MAX.}} = \frac{16}{\pi d_o^3} \sqrt{M^2 + T^2}$$
$$= \frac{16}{\pi (.50)^3} 551$$

$$S_{s \text{ MAX.}} = 22,400 \text{ PSI}$$

Application Factor ( $K_A$ ) = 2.2  
Fatigue Life Factor ( $L_f$ ) = 1.0

$$\underline{S_{s \text{ MAX.}} = 49,400 \text{ PSI}}$$

Maximum Allowable  $S_{s \text{ MAX.}}$  is 50,000 PSI

### Bursting Stresses (Internally Splined Parts)

#### Radial Force Component at the Pitchline ( $S_1$ )

$$S_1 = \frac{T \tan \phi}{\pi D t w F}$$
$$= \frac{551 \tan 30^\circ}{\pi \times 1.062 \times .131 \times .781}$$

$$\underline{S_1 = 931 \text{ PSI}}$$

#### Centrifugal Force ( $S_2$ )

$$S_2 = 0.828 \times 10^{-6} \times n^2 \times (2 D o i^2 + 0.424 D r i^2)$$
$$= 0.828 \times 10^{-6} \times 4000^2 \times (2 \times 1.438^2 + 0.424 \times 1.175^2)$$
$$= 0.828 \times 16 \times (4.13 + .59)$$

$$\underline{S_2 = 62.5 \text{ PSI}}$$

#### Tangential Force Components at the Pitchline ( $S_3$ )

$$S_3 = \frac{4T}{D^2 F_e Y}$$
$$= \frac{4 \times 551}{1.062^2 \times .562 \times 1.5}$$

$$\underline{S_3 = 2320 \text{ PSI}}$$

# 105mm Howitzer Splitter Drive

## SPLINE CALCULATIONS

### Total Stresses Tending to Burst Rim

$$S_t = K_A K_m (S_1 + S_3) + S_2$$
$$= 2.2 \times 1 (931 + 2320) + 62.5$$

$$S_t = \underline{7310 \text{ PSI}}$$

Life Factor = 1.0

Maximum Allowable  $S_t$  is 50,000 PSI

On The Basis Of These Calculations,  
The Input Shaft And Splines Are  
Adequately Designed.

### Output Spline

17 Teeth, 16/32 Pitch, 1.062 Pitch Dia., 0.8 Long

### Shear Stresses in Teeth

$$S_s = \frac{4T K_m}{DNF_e t_c}$$
$$= \frac{4 \times 705 \times 1 \times 2 \times 17}{1.062 \times 17 \times .8 \times 1.062}$$

$$S_s = 6230 \text{ PSI}$$

Application Factor = 2.2

$$S_s = \underline{13,700 \text{ PSI}}$$

Maximum Allowable  $S_s$  is 50,000 PSI

### Compressive Stresses in Teeth

$$S_c = \frac{2TK_m}{DNF_e h}$$
$$= \frac{2 \times 705 \times 1}{1.062 \times 17 \times .8 \times .062}$$

105mm Howitzer Splitter Drive

SPLINE CALCULATIONS

$$S_c = 1575 \text{ PSI}$$

$$\text{Application Factor} = 2.2$$

$$\text{Wear Life Factor} = 1.4$$

$$S_c = \frac{1575 \times 2.2}{1.4}$$

$$\underline{S_c = 2480 \text{ PSI}}$$

Maximum Allowable  $S_c$  is 4000 PSI

Bursting Stresses (Internally Splined Parts)

Radial Force Component at Pitchline ( $S_1$ )

$$S_1 = \frac{T \tan \phi}{\pi D t w F}$$
$$= \frac{705 \tan 30^\circ}{\pi \times 1.062 \times .131 \times .8}$$

$$\underline{S_1 = 1165 \text{ PSI}}$$

Centrifugal Force ( $S_2$ )

$$S_2 = 0.828 \times 10^{-6} \times n^2 \times (2D_o i^2 + 0.4240 r i^2)$$
$$= 0.828 \times 10^{-6} \times 2500^2 \times (2 \times 1.58^2 + 0.424 \times 1.175^2)$$
$$= 0.828 \times 6.25 \times (5.0 + .59)$$

$$\underline{S_2 = 28.9 \text{ PSI}}$$

Tangential Force at the Pitchline ( $S_3$ )

$$S_3 = \frac{4T}{D^2 F_c Y}$$
$$= \frac{4 \times 705}{1.062^2 \times .8 \times 1.5}$$

$$\underline{S_3 = 2080 \text{ PSI}}$$

105mm Howitzer Splitter Drive

SPLINE CALCULATIONS

Total Stresses Tending to Burst Rim

$$\begin{aligned} S_t &= K_A K_M (S_1 + S_2) + S_3 \\ &= 2.2 \times 1.0 \times (1165 + 2080) + 29 \end{aligned}$$

$$\underline{S_t = 7170 \text{ PSI}}$$

Life Factor = 1.0

Maximum Allowable  $S_t$  is 50,000 PSI

On The Basis Of These Calculations, The Output Spline Is Adequately Designed.

<p>CLASSIFIED</p> <p>1 105MM HOWITZER</p> <p>2 AUXILIARY PROPELLION</p> <p>3 CONTRACT NO DA-11-070-ORD-134</p>	<p>SECRET</p> <p>AD _____ ACCESSION NO. _____</p> <p>Sundstrand Aviation, Division of Sundstrand Corporation, Rockford, Illinois.</p> <p>DESIGN AND DETAIL OF AN AUXILIARY PROPELLED 105mm HOWITZER - Walter J. Zierzycki 45 pages - Illustrations - Tables - Unclassified Report - April 1962</p> <p>Contract No DA-11-070-ORD-134 Modification 1</p> <p>This report summarizes the considerations involved in the design and detailing of an auxiliary propulsion system for the 105mm Howitzer.</p> <p>The design is based on 3.2 in<sup>3</sup> rev. hydraulic pumps and motors which use the same basic parts as the hydraulic unit used on the auxiliary propelled 155mm Howitzer.</p> <p>The basis for selecting the engine, pump and hydraulic motor is discussed along with the calculations used to arrive at the final drive ratio, the weapon's top speed and range and the magnitude of the hydraulic line losses. All of the remaining items required by the system are treated separately.</p> <p>Four layout and 89 assembly and detail drawings were prepared during the contract and reproducible copies of all on Ordnance Department format were supplied to Rock Island Arsenal.</p>	<p>CLASSIFIED</p> <p>1 105MM HOWITZER</p> <p>2 AUXILIARY PROPELLION</p> <p>3 CONTRACT NO DA-11-070-ORD-134</p>
<p>CLASSIFIED</p> <p>1 105MM HOWITZER</p> <p>2 AUXILIARY PROPELLION</p> <p>3 CONTRACT NO DA-11-070-ORD-134</p>	<p>SECRET</p> <p>AD _____ ACCESSION NO. _____</p> <p>Sundstrand Aviation, Division of Sundstrand Corporation, Rockford, Illinois.</p> <p>DESIGN AND DETAIL OF AN AUXILIARY PROPELLED 105mm HOWITZER - Walter J. Zierzycki 45 pages - Illustrations - Tables - Unclassified Report - April 1962</p> <p>Contract No DA-11-070-ORD-134 Modification 1</p> <p>This report summarizes the considerations involved in the design and detailing of an auxiliary propulsion system for the 105mm Howitzer.</p> <p>The design is based on 3.2 in<sup>3</sup> rev. hydraulic pumps and motors which use the same basic parts as the hydraulic unit used on the auxiliary propelled 155mm Howitzer.</p> <p>The basis for selecting the engine, pump and hydraulic motor is discussed along with the calculations used to arrive at the final drive ratio, the weapon's top speed and range and the magnitude of the hydraulic line losses. All of the remaining items required by the system are treated separately.</p> <p>Four layout and 89 assembly and detail drawings were prepared during the contract and reproducible copies of all on Ordnance Department format were supplied to Rock Island Arsenal.</p>	<p>CLASSIFIED</p> <p>1 105MM HOWITZER</p> <p>2 AUXILIARY PROPELLION</p> <p>3 CONTRACT NO DA-11-070-ORD-134</p>
<p>SECRET</p> <p>AD _____ ACCESSION NO. _____</p> <p>Sundstrand Aviation, Division of Sundstrand Corporation, Rockford, Illinois.</p> <p>DESIGN AND DETAIL OF AN AUXILIARY PROPELLED 105mm HOWITZER - Walter J. Zierzycki 45 pages - Illustrations - Tables - Unclassified Report - April 1962</p> <p>Contract No DA-11-070-ORD-134 Modification 1</p> <p>This report summarizes the considerations involved in the design and detailing of an auxiliary propulsion system for the 105mm Howitzer.</p> <p>The design is based on 3.2 in<sup>3</sup> rev. hydraulic pumps and motors which use the same basic parts as the hydraulic unit used on the auxiliary propelled 155mm Howitzer.</p> <p>The basis for selecting the engine, pump and hydraulic motor is discussed along with the calculations used to arrive at the final drive ratio, the weapon's top speed and range and the magnitude of the hydraulic line losses. All of the remaining items required by the system are treated separately.</p> <p>Four layout and 89 assembly and detail drawings were prepared during the contract and reproducible copies of all on Ordnance Department format were supplied to Rock Island Arsenal.</p>	<p>CLASSIFIED</p> <p>1 105MM HOWITZER</p> <p>2 AUXILIARY PROPELLION</p> <p>3 CONTRACT NO DA-11-070-ORD-134</p>	

UNCLASSIFIED

UNCLASSIFIED