

AEDC-TDR-62-137



**INDUCTIVE POWER SUPPLY
FOR A HOTSHOT-TYPE TUNNEL**

By

A. H. Fillers, Jr.

**von Kármán Gas Dynamics Facility
ARO, Inc.**

TECHNICAL DOCUMENTARY REPORT NO. AEDC-TDR-62-137

July 1962

PROPERTY OF U. S. AIR FORCE
AEDC LIBRARY
AF 40(600)-600

(Prepared under Contract No. AF 40(600)-1000 by ARO, Inc., contract operator of AEDC, Arnold Air Force Station, Tennessee.)

**ARNOLD ENGINEERING DEVELOPMENT CENTER
AIR FORCE SYSTEMS COMMAND
UNITED STATES AIR FORCE**

NOTICES

Qualified requesters may obtain copies of this report from ASTIA. Orders will be expedited if placed through the librarian or other staff member designated to request and receive documents from ASTIA.

When Government drawings, specifications or other data are used for any purpose other than in connection with a definitely related Government procurement operation, the United States Government thereby incurs no responsibility nor any obligation whatsoever; and the fact that the Government may have formulated, furnished, or in any way supplied the said drawings, specifications, or other data, is not to be regarded by implication or otherwise as in any manner licensing the holder or any other person or corporation, or conveying any rights or permission to manufacture, use, or sell any patented invention that may in any way be related thereto.

INDUCTIVE POWER SUPPLY
FOR A HOTSHOT-TYPE TUNNEL

By

A. H. Fillers, Jr.

von Kármán Gas Dynamics Facility

ARO, Inc.

a subsidiary of Sverdrup and Parcel, Inc.

July 1962

FOREWORD

Acknowledgment is given for the valuable preliminary work on this report by Mr. R. H. Guess of the General Electric Company, formerly of the von Karman Gas Dynamics Facility, ARO, Inc.

ABSTRACT

This report covers the development and operation of a 5×10^6 joule, inductive-storage power supply for a hotshot-type wind tunnel. A discussion of the equipment and its auxiliaries is given.

CONTENTS

	<u>Page</u>
ABSTRACT	v
NOMENCLATURE	ix
1.0 INTRODUCTION	1
2.0 PRINCIPLE OF OPERATION	1
3.0 THEORY OF OPERATION	2
4.0 DESCRIPTION OF COMPONENTS	
4.1 Unipolar Generator.	4
4.2 Drive Motor	5
4.3 Magnetic Clutch	6
4.4 Flywheel	6
4.5 Shear-Pin Coupling	6
4.6 Induction Coil	6
4.7 Charge Loop Switch, S-1	7
4.8 Discharge Loop Switch, S-2	7
4.9 Shorting Switch	7
4.10 Bus Work	8
4.11 Nitrogen System	8
4.12 NaK Bubbler	9
5.0 INSTRUMENTATION	9
6.0 MODE OF OPERATION	10
6.1 Discharge Shorting Switch	12
6.2 System Grounding	12
7.0 CALIBRATION OF THE UNIPOLAR GENERATOR	12
7.1 Saturation Curve	13
7.2 Open Circuit Pulse Test	13
7.3 Closed Loop Pulse Test	13
8.0 MAINTENANCE	13
9.0 OVERHAUL	14
9.1 NaK Handling	15
9.2 Reassembly	16
9.3 NaK Oxidation	16
10.0 RESULTS	16
11.0 CONCLUDING REMARKS	17
REFERENCES	17
APPENDIX I: History of System Development	19

ILLUSTRATIONS

<u>Figure</u>	<u>Page</u>
1. Curve of Buildup and Decay of Current	23
2. Typical Current, Voltage, and Resistance Traces with and without Short Circuit Switch	24
3. Calculated Generator Performance	25
4. Unipolar Generator Drive Unit	26
5. Cross Section - Unipolar Generator	27
6. Unipolar Generator	28
7. M-G Exciter and Electrical Equipment	29
8. Drive Motor and Magnetic Clutch	30
9. Flywheel and Koppers Shear-Pin Coupling	31
10. Magnetic Energy Storage Coil	32
11. S-1 CA Breaker	33
12. Breaker Contact Modification	34
13. S-2 Switch	35
14. Shorting Switch	36
15. Bus	37
16. Flywheel Insulation Damage	38
17. NaK Transfer Tank	39
18. Schematics of Circuits Used in 50" Hyper- velocity Tunnel Development	40
19. Resumé of Performance of Stages of 50" Hyper- velocity Tunnel Development	41
20. Selenium Rectifier and Temporary Coil	42
21. Collector	43
22. Breaker	43

NOMENCLATURE

C	Capacitance analagous to flywheel and generator, farads
di/dt	Rate of change of current
E_c	Energy stored in inductance during charge cycle
$^{\circ}F$	Temperature, degrees Fahrenheit
G	Generator
H	Hydrogen
hp	Horsepower
I	Current, amperes
K	Potassium
kv	Kilovolt
L	Inductance, henries
mcm	Million circular mils area
Na	Sodium
O	Oxygen
R	Resistance, ohms
R_a	Resistance of the arc
R_c	Equivalent charge loop resistance
V	Volts
V_o	Terminal voltage of generator at start of pulse
V_t	Terminal voltage
μ	Micro
τ_D	Time constant for discharge cycle
ϕ	Flux from field coils
Ω	Ohms
ω	Angular velocity

1.0 INTRODUCTION

Studies at the University of Michigan (Ref. 1) indicated that in the energy levels desired for operation of a large hotshot-type tunnel*, an inductive power supply would be more economical than a capacitive type. Therefore an inductive system was developed as a drive for the 50-in. Hypervelocity Tunnel, Hotshot 2, of the von Kármán Gas Dynamics Facility (VKF), Arnold Engineering Development Center (AEDC), Air Force Systems Command (AFSC).

This 5×10^6 joule, inductive-storage power supply uses a unipolar generator with flywheels to charge an air core coil that is discharged by an arc inside an arc chamber. At the present time the supply is operating at two-thirds energy level.

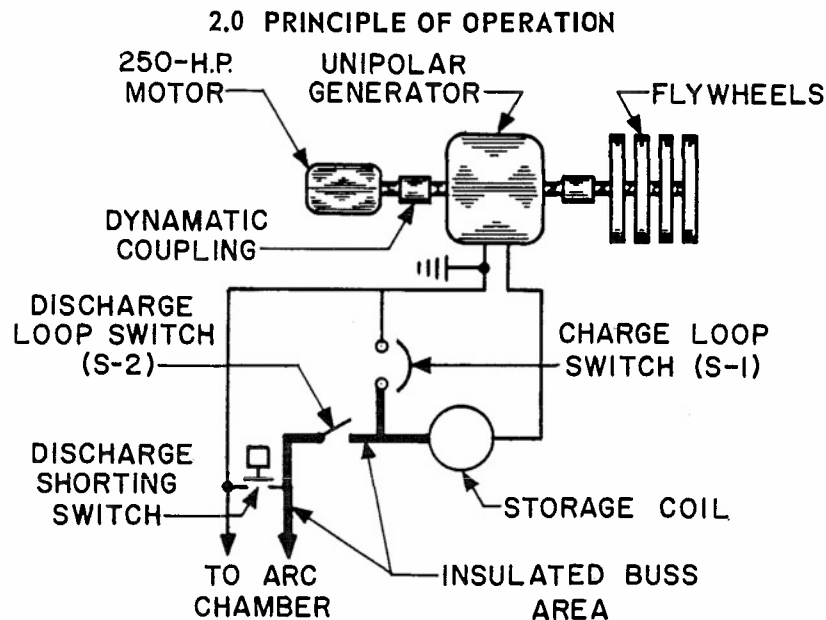

A circuit diagram of the inductive power supply for the 50-in. Hypervelocity Tunnel, as presently used**, is shown above. The current flows from the generator through the charge loop switch S-1 to the coil and back to the generator. This current builds up from $I = 0$ at $T = 0$ to $I = I_{max}$ at $T = T_1$ (Fig. 1). At the present time the operating procedure is to decrease the generator voltage during the charge cycle. This method and an alternate one are discussed in section 6.0.

* See Ref. 2 for information on hotshot tunnels.

Manuscript released by author June 1962.

** Earlier configurations of the power supply and history of its development are described in the Appendix, p. 19.

At $T = T_1$ the discharge loop switch S-2 closes, placing the arc chamber in parallel with S-1. The generator current divides, and approximately five-percent current transfers to the arc chamber. S-1 is now opened, and the generator field is opened. When S-1 clears its arc, all the current has been transferred to the arc chamber. A copper fuse is connected across the electrodes in the arc chamber. This fuse is sized to carry the full current for approximately ten milliseconds before blowing apart. When the fuse blows, it ionizes the gas between the electrodes and pulls an arc. The arc introduces a higher resistance into the circuit changing di/dt . Since the coil voltage $E_c = -L di/dt$, the voltage rises to a value sufficient to continue the current through the arc (Fig. 2). Experimental data show that the arc resistance R_a starts at approximately 0.01 ohm and increases to in excess of 0.02 ohm (Fig. 2). The average value is from 0.019 to 0.020 ohm.

The decay of current is practically linear over the total time instead of having a normal exponential decay because the arc resistance is changing. The decay of current is essentially over in two time constants instead of four.

$$\tau_D = \frac{L}{R_a} = \frac{340 \times 10^{-6}}{0.02} = 17 \text{ milliseconds}$$

so

$$2 \tau_D = 34 \text{ milliseconds}$$

At 2τ little energy remains in the coil, and the arc extinguishes.

3.0 THEORY OF OPERATION

The power supply is analogous to a simple RLC circuit. When the generator and flywheel are at rated speed, the stored energy E_c is contained in the rotating mass.

$$E_c = 1/2 I \omega^2$$

I = Moment of inertia

ω = Angular velocity

It was pointed out by Boyajian (Ref. 3) that a freely turning d-c motor or generator with negligible internal inductance and a constant applied field would behave effectively as a condenser. The terminal voltage of such a machine will be a linear function of the angular velocity ω ,

and the rotational kinetic energy stored in such a machine will be proportional to the square of ω and hence proportional to the square of the terminal voltage, as in condenser storage. Thus

$$E_c = (\text{constant}) \times V^2$$

where constant capacitance is equal to

$$C = 2 E_c / V^2$$

or

$$E_c = C V^2 / 2$$

Thus, a flywheel-driven generator charging an inductance with resistance in the circuit represents a familiar RLC circuit. Depending on the relative values of R , L , and C , the system can be overdamped, critically damped, or oscillatory. The particular values obtained for this system are:

$$L = 340 \mu\text{h}$$

$$R_c = 135 \mu\Omega$$

$$E_c = 4.6 \times 10^7 \text{ joules}$$

$$V_0 = 70 \text{ volts}$$

This system will operate close to the critically damped condition up to approximately 40.8 volts. Above this value it becomes oscillatory. The charge circuit can be represented as follows:

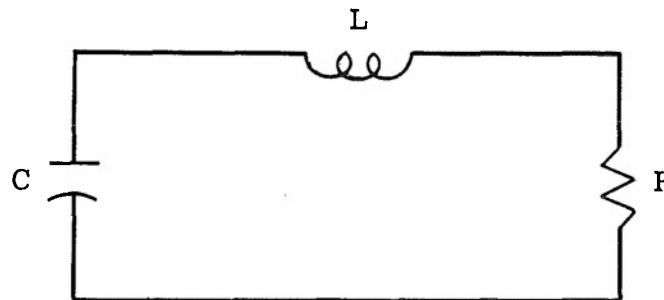

The voltage drops may be written:

$$L \frac{di}{dt} + Ri + 1/C \int i dt = 0$$

$$i = K_1 e^{(-a + b)t} + K_2 e^{(-a - b)t}$$

where

$$a = R/2L \text{ and } b = \sqrt{R^2/4L^2 - 1/LC}$$

Solving for the current (see Ref. 4),

$$i = \frac{C V}{\sqrt{R^2 C^2 - 4LC}} \left[e^{(-R/2L + \sqrt{R^2/4L^2 - 1/LC}) t} - e^{(-R/2L - \sqrt{R^2/4L^2 - 1/LC}) t} \right]$$

Using the previous expressions, the generator performance has been calculated for $E_c = 4.6 \times 10^7$ joules and for voltages of 20, 30, and 40 volts (Fig. 3).

4.0 DESCRIPTION OF COMPONENTS

4.1 UNIPOLAR GENERATOR

The unipolar generator drive unit is shown in Fig. 4. The generator (Figs. 5 and 6) consists of a solid steel rotor turning within a stator on which are mounted annular field coils. A potential is produced between the two quarter points of the rotor, and current is extracted from the rotor circumference at two stator collector areas. The surface of the rotor is insulated except at the collector areas. The running clearance is small, and the current is carried from the rotor to the collector rings on the stator by a bath of liquid metal. The unipolar principle is not new (Ref. 5); it was invented by Barlow in 1823. Later versions were developed by Faraday in 1831, Siemens in 1878, and Meyer in 1896. These early versions of the unipolar generator were hampered by low speed, low voltage, and poor efficiency, approximately 88 to 90 percent. The most important innovation made was the use of liquid metal to collect current from the rotor.

The liquid metal is an alloy of 56-percent potassium and 44-percent sodium, known as NaK (Ref. 6). It is a silver-colored metal whose specific gravity is 0.8, and it solidifies at 68°F. When NaK is exposed to air, an oxide forms on its surface. Oxide is prevented in normal operation by keeping the liquid under an inert (N₂) atmosphere. The oxide is a thick, grey substance resembling putty. NaK reacts violently with water according to $\text{NaK} + 2\text{H}_2\text{O} \rightarrow \text{NaOH} + \text{KOH} + \text{H}_2 + \text{heat}$. The heat of reaction is usually sufficient to ignite the hydrogen as it comes in contact with the oxygen of the air, and it is this reaction which is highly explosive. The hydroxides occur as toxic white smoke. Normal fire-fighting methods cannot be used on NaK fires because of reaction with either water or carbon tetrachloride. Best results are obtained by smothering with treated sodium chloride powder called "Metl-X" or with powdered graphite.

The NaK is continually circulated through the generator by a pumping system. The original pumps were magnetic pumps consisting of a stainless steel sleeve surrounded by a three-phase motor winding. The flux from these coils created a motor force on the NaK when current was passed through the windings perpendicular to the desired path of NaK circulation. Flow rate was adjusted by varying the voltage supplied to the motor windings. In 1958 new self-priming centrifugal pumps

were installed to provide a higher pumping rate. The new pumps are driven directly by a 3/4-hp, three-phase, 220/440-volt motor.

The d-c excitation for the unipolar generator field coils is supplied by a 15-kw motor-generator set (Fig. 7). The induction motor is 20 hp, 440 v, and three-phase. The generator is directly coupled to the motor and has a variac connected in its own field circuit to vary the open circuit voltage from 0 to 150 v.

The generator and flywheel bearings are lubricated by a system which includes three oil pumps. An electrically driven pump is used as a lift pump during the initial starting process. A 475-psi pressure is attained against the flywheel shaft. This provides a lift of less than one mil, but this oil is sufficient to lubricate the bottom of the shaft.

Another pump is considered to be the main oil pump. It is driven by a 1/2 hp, 440 v, three-phase motor and puts out 18 psi into a 1 1/4-in. header. Taps are made through 1/4-in. throttling valves to the four bearings. The third pump is belt-driven from the flywheel shaft. The system is designed so that through a pressure regulator both pumping systems are normally operating in parallel. The belt-driven pump will not maintain pressure below 400 rpm. A gravity feed system has also been provided to cover the speed range from 400 rpm to zero speed in case of a power failure.

A single-pass, oil-to-water cooler is located in the oil feed line to the bearings. Temperature bulbs in the flywheel bearing return lines monitor the oil temperature and give a visual warning on the control panel. The temperature bulbs are set for 160°F.

4.2 DRIVE MOTOR

The prime mover for the unipolar generator and flywheel is a 3570-rpm, 250-hp, 440 v, three-phase, 60-cycle, a-c, squirrel cage, induction motor (Fig. 8). The full load motor current is 287 amperes. The motor is of open-frame construction and is started across-the-line. The control equipment used is a 400-ampere, manual-closed, air circuit breaker with 115-percent overload protection and a size 6 contactor. The control of the contactor is 125 v, d-c, supplied by a selenium rectifier. The contactor is closed remotely from the main control panel. A 400-ampere, three-pole, double throw, manual switch is installed between the circuit breaker and contactor for reversing the motor (Fig. 7). A braking action is obtained by reversing the motor and energizing the magnetic clutch.

4.3 MAGNETIC CLUTCH

The clutch device used between the drive motor and the generator is a water-cooled, magnetic coupling rated at 250-hp with 220 v, d-c, excitation coils (Fig. 8). The principle of operation is similar to a motor action. The drive motor end is fastened to a thin drum about 1/16-in. thick, and the generator end, to a heavy, corrugated casting. The clearance between the rotating and stationary parts is 0.020 in. nominal. Rotation of the drum in the magnetic field produced by the coils wound in the stator causes eddy currents in the drum. The added flux lines from the eddy currents are used to pull the generator casting, thereby rotating the generator. The coupling excitation is raised slowly, and the generator is accelerated to full speed. The slip in the magnetic coupling at full speed is 20 rpm.

4.4 FLYWHEEL

The variable, energy-storage flywheel (Fig. 9) was added to increase the rotational kinetic energy storage from 1.3×10^7 to 4.6×10^7 joules. The flywheel consists of five equal segments of stored energy, i. e., a shaft plus four removable disks. This arrangement makes it possible for the power supply to be operated in six separate energy steps: (1) the unipolar generator alone, (2) the generator plus the flywheel shaft, (3 to 6) the generator and shaft plus 1 to 4 disks.

4.5 SHEAR-PIN COUPLING

A shear-pin coupling (Fig. 9) was placed between the generator and flywheel to protect the generator from severe short circuits. The shear pins are designed to break if the decelerating torque exceeds 20,000 lb-ft, thus removing the energy of the flywheel from the generator, minimizing damage. The coupling is designed so that upon breaking the shear pins, springs pull the coupling plates apart and the two shaft sections are separated.

4.6 INDUCTION COIL

The coil (Fig. 10) has an air core and is wound with 36 parallel 850-mcm cables. Each cable is fully transposed to make all cables the same length. Each cable is insulated for 15 kv. Ceramic spacers support the layers of cables, and 18-kv pedestal-type insulators support the whole coil. The terminals are brought out at the top and bottom

of the coil. The coil is 8 ft in diameter by 10 ft high, weighs 40,000 lb, and has an inductance of 340×10^{-6} henries and a resistance of 135×10^{-6} ohms. It is designed to carry 300,000 amperes and store 1.53×10^7 joules.

4.7 CHARGE LOOP SWITCH, S-1

A switch is required in the charge loop of the bus to open under load and extinguish the resulting arc (transferring the current into the discharge loop) and to carry the slow build-up current to the coil.

This switch, S-1, is in parallel with the arc chamber. At the present time a stripped version of a 14.4-kv, 4000-ampere, three-phase, air blast breaker (Fig. 11) with modified arcing contacts (Fig. 12) has proved capable of handling currents of 176,000 amperes with a minimum of trouble. It has dissipated the total stored energy of the coil when the discharge circuit malfunctioned with only minor damage.

4.8 DISCHARGE LOOP SWITCH, S-2

S-2 is a switch which was designed and fabricated locally to transfer the charge loop current into the discharge loop. Investigation of the requirements proved that there were no commercially available switches for this purpose. The switch consists of an air-operated piston, copper bars, and insulators (Fig. 13). Early attempts to operate the discharge loop in parallel with S-1 during the charge cycle caused excessive heating of the arc chamber electrodes. The installation of S-2 allows the required heat capacity of the electrodes to be quite low, easing the design requirements of the high pressure arc chamber.

4.9 SHORTING SWITCH

A shorting switch (Fig. 14) has been fabricated and installed in parallel with the arc chamber electrodes to extinguish the arc at a predetermined time.

The switch consists of an angle and channel steel frame. A 6-in. air cylinder is mounted on the frame, and the rod is fastened through an insulator to a copper plate. The copper plate has two "G-14" tungsten alloy bars silver-soldered to the plate to serve as contacts. Matching contacts are provided on the stationary bus work on the

positive and negative buses. The switch uses a fulcrum and lever arm principle to hold the movable parts prior to operation. The lever arm is attached to a fuse wire which is blown by current in a secondary loop wrapped around the large energy storage coil. When the switch is set up for a test, the fuse wire is installed with the air cylinder and movable contact de-energized; then pressure is admitted to the air cylinder. When the fuse wire blows, releasing the lever arm, the piston pushes the copper plate into the stationary bus.

The control of timing is accomplished by varying the gap and by changing the pressure. With this switch arc times may be varied from 5 to 15 milliseconds.

The shorting switch closes in on approximately 100,000 amperes and returns the system into a closed-loop condition. The current requires from six to eight seconds to decrease to zero.

4.10 BUS WORK

The bus work (Fig. 15) was locally fabricated to have 14 percent of the total charge loop resistance. Whenever possible, coaxial or low inductive bus was used to minimize the forces on the bus. The bus was designed so that its inductance would be mutually coupled additionally to that of the coil so as not to decrease the energy storage available. This effect is five percent of the total inductance or 17 microhenries.

4.11 NITROGEN SYSTEM

A nitrogen system is furnished to supply a continuous flow of nitrogen into the unipolar generator. The nitrogen provides an inert atmosphere to prevent oxidation of the liquid metal NaK in the generator.

The system is fed through a pipe line from a central storage system at 2000 psi. A check valve is installed in the line before it ties into a ten-bottle manifold system. The manifold system may be separated into a six-bottle and a four-bottle bank. A separate flow regulator with a maximum flow of 40 CFH is used from each bank to the generator. A pressure switch arrangement opens the line to the six-bottle bank and holds the four-bottle bank in reserve. At 300 psi the pressure switch operates and places the four-bottle bank in service. Indicating pilot lights monitor the two systems.

4.12 NaK BUBBLER

A tank has been installed in the nitrogen line to the generator. The tank has a quantity of NaK in the bottom and a filter near the top. The inlet nitrogen line extends into the tank and terminates below the surface of the NaK. The nitrogen bubbles through the NaK and up through the filter which removes any NaK particles picked up by the nitrogen. An outlet line leaves the bubbler tank and continues to the generator.

The purpose for this equipment is to remove any impurities such as moisture or oxygen which are mixed with the nitrogen.

The bubbler gradually accumulates oxide and is drained, cleaned, and refilled with fresh NaK.

5.0 INSTRUMENTATION

The instrumentation is divided into two basic classes. These are the instruments normally associated with rotating machines and those especially developed for monitoring the energy pulse.

The conventional instrumentation includes:

- (1) exciter voltage,
- (2) generator voltage,
- (3) generator rpm,
- (4) coupling cooling water temperature,
- (5) NaK temperature, and
- (6) drive motor current.

The pulse instrumentation is continually under development. The high magnetic field level and the electrical noise during arc discharge makes improvement quite difficult. The principal units now being used are:

1. The coil voltage is recorded on a recording oscillograph to indicate power supply performance and to determine timing of the arc discharge. The trace also indicates peak voltage which is of interest from the insulation requirements. The rapid rise of coil voltage is also used as a timing signal for tunnel instrumentation.

2. The arc voltage is recorded similarly to the coil voltage. Two sensitivities are used for measuring this item. The more sensitive voltage trace is used for determining timing and arc initiation accurately. The less sensitive arc voltage trace is used to interpret the performance and to calculate arc resistance, power input, and energy delivered.

3. Inductive loops are placed around different sections of the bus and around the coil to study switching and timing. These loops give the di/dt of the current under study, and these signals are also recorded on the high speed recorder.

4. The pressure in the arc chamber is measured by two pressure transducers and is recorded on a high speed oscillograph through a carrier amplifier with appropriate circuitry. This measurement is of primary concern to the tunnel data but also gives useful information to the power supply in determining energy transfer, efficiency, grounding, or faults.

5. Generator current is measured by a circuit employing a Hall Effect Generator. This circuit has a linearity that is well within the two-percent accuracy of the high speed oscillograph on which its output is recorded. Circuits have been developed and are now undergoing calibration for measuring the power input and energy input to the arc chamber.

A recorder, operating at a speed of one cm/sec, is being used to record the generator speed, voltage, and current during the charge cycle. This recorder is located in the control room and is monitored while the generator is operating. This recorder indicates generator trouble, and the operator can shut down the generator before further damage can occur.

Future developments are planned to use the output of the present instrumentation to calculate instantaneously the energy stored in the flywheel, energy in the coil, the arc resistance, and the efficiency of transfer from machine to coil and from coil to the arc chamber gas.

6.0 MODE OF OPERATION

The power supply may be operated in two different ways. The mode followed from December 1956 until May 1961 was as follows:

1. The charge loop switch S-1 is closed.
2. The generator and flywheel are accelerated to full speed.

3. The exciter m-g set is started, and an open circuit voltage is preset.
4. The exciter voltage is applied to the generator coils.
5. The voltage and current build up in the field coils.
6. The generator terminal voltage builds up exponentially, and current increases in the charge loop.
7. The generator voltage (V_t) reaches its peak and starts to reduce slowly as the rpm is falling off.
8. The current lags the voltage and peaks at a later time.
9. At peak current (I_{max}) timers close S-2, putting the arc chamber in parallel with S-1.
10. S-1 opens, putting all the current through the arc chamber fuse.
11. When the fuse blows, the coil voltage rises and the rapid discharge is accomplished.

The present mode of operation differs in several respects from the original one and results in better repeatability.

This method is as follows:

1. The generator and flywheel are brought up to rated speed.
2. Field excitation is applied to the generator, and the generator's terminal open circuit voltage (V_o) is set to a predetermined value.
3. The charge loop switch S-1 is closed, applying the inductive load to the generator.
4. The current rises to maximum exponentially, reaches peak (I_{max}), and starts to decay (Fig. 3).
5. No steady-state condition exists because the speed of the flywheel and generator decreases as they convert rotational energy into electrical energy.

The voltage falls off during the charging cycle since

$$V_o = KN\phi$$

$$K = \text{constant}$$

$$N = \text{rpm}$$

$$\phi = \text{applied flux}$$

The transfer to the arc chamber is accomplished as described before.

6.1 DISCHARGE SHORTING SWITCH

The discharge in the arc chamber must be made in the shortest time practical because of the aerodynamic considerations. The discharge shorting switch, described in section 4-9 above, is used for that purpose. To obtain a given energy into the gas in a shorter time, it was necessary to increase the initial current I_0 .

When the shorting switch closes (Fig. 2), the arc goes out, and the current decays to zero at a much slower rate. The remaining energy is given up as heat in the bus.

6.2 SYSTEM GROUNDING

Initially the power supply was operated ungrounded or floating. Since it was impossible at this time to prevent grounding at least at one spot, the generator was left floating to prevent a return path through the reinforcing steel, conduits, etc. Occasionally a voltage flashover to ground occurred and in turn broke down the insulation on the generator or flywheel (Fig. 16). Current passing through the bearings caused damage to the bearings and shaft.

In 1961 a decision was made to properly insulate the high voltage bus and ground one terminal of the generator. The arc chamber block was kept insulated, and the one electrode was tied to the bus which was grounded. In this manner only one ground is on the system. The part of the bus which is subjected to the coil voltage is insulated to withstand in excess of 10 kv.

A mechanical knife blade switch has been installed in the ground connection to permit the bus work insulation to be checked for each run.

7.0 CALIBRATION OF THE UNIPOLAR GENERATOR

Calibrating the generator is required after each overhaul period and periodically between overhauls. There is no way at present of setting a particular value of current. The only adjustable variables are excitation and time.

7.1 SATURATION CURVE

The saturation curve for the generator shows the variation of generator terminal voltage as a function of excitation voltage or flux. This can be compared to the calculated curve and also with previously obtained curves to show the condition of the generator.

The values for this curve are obtained by preventing the motor from disconnecting from the generator after it has reached full speed. The generator is open circuited, the excitation is raised, and the generator terminal voltage is read for various excitation levels.

7.2 OPEN CIRCUIT PULSE TEST

Several open circuit pulse tests are run to test the excitation system and the generator's ability to generate voltage. Any internal insulation problems would be detected in this manner.

7.3 CLOSED LOOP PULSE TEST

The closed loop tests are the most important tests to be run with the generator prior to actually firing into the arc chamber. These tests are made with the charge loop switch S-1 closed and S-2 open. Pulses are made at varying voltages from five volts up to 54 volts at the present time. Instrumentation monitors the terminal voltage rise and also the current rise. When the current reaches its maximum, $di/dt = 0$, the coil voltage is measured, and the current is calculated by Ohm's Law, $I = V/R_c$. Therefore the deflection of the current measuring device can be calibrated, and also the time from initiation of the pulse to peak current can be determined. This time is used in setting up the automatic timers so that transfer into the arc chamber occurs at peak current. With the data points from this series of runs, the generator controls can be set for the desired level of current.

8.0 MAINTENANCE

There is very little maintenance which can be performed while the system is operating. The oil pumps run 24 hours a day and periodically may wear out the bearings. There is a spare pump which can be installed while a defective pump is being repaired. A daily check is made of the insulation level. Every two months the bus and bus insulators are cleaned with a solvent.

One of the most critical hurdles in the operation of an inductive power supply is the commutation of current from the charge loop to the discharge loop. A discharge loop of low resistance and inductance is required. A high current switch S-1 or circuit breaker must be able to withstand the forces during the charge cycle and also be able to carry currents in excess of 160,000 amperes. This switch must open under load and interrupt the resulting arc with only a small percentage of energy lost. A switch of this type does not have the advantage of an a-c circuit breaker which is aided by current zero. A development of switches has taken place to determine a suitable type (See Appendix I). The switch (S-1) being used at the present time is a 14.4-kv, 4000-ampere, three-pole, a-c switch. This breaker uses an air blast to lengthen and cool the arc during interruption. The maintenance on the original contacts was excessive in both time and cost. The male and female contacts experienced burning which eroded the contact areas. The male contacts were furnished with a small tip of tungsten. Because of the higher currents used in this service, the arc would leave the small piece of tungsten and travel to the unprotected copper alloy portions. The male contact was also tapered to act as a wedge into the female contact. This resulted in only a line contact area on the sides. As the breaker started to open, arcing was experienced in the gap portion between the male and female parts. It became necessary to rebuild the contacts after every three runs. This was accomplished by brazing the damaged areas and attempting to reshape them on a milling machine.

A modification to reduce the maintenance was performed (Fig. 12). Tungsten alloy inserts were installed to cover over twice the area of the original tungsten piece. The male contact was built up to avoid the taper. In this way the contact area and the wiping action on interruption were increased. Little internal arcing occurs to the female contact. The arc stays on the G-14 tungsten as the arc is pulled, and only minor damage occurs. Replacement rates on the modified contacts are 1 in 40 runs. The contacts can be rebuilt and reused.

9.0 OVERHAUL

Experience has proven that an overhaul of the unipolar generator is desired every six to eight months in normal use.

9.1 NaK HANDLING

Removing the NaK from the generator requires careful planning. The craftsman wears a hood with a plexiglass face shield, a waist length jacket, and long pants made of chrome leather and elbow length gloves and leggings to prevent any exposure.

NaK transfer tanks are provided to take the NaK as it is drained from the generator (Fig. 17). The tanks are dried and cleaned; nitrogen is used to purge the tanks. A small amount of mineral oil is poured into the tanks to help prevent air contacting the NaK during transfer.

The tanks have an opening on top with a cover which is removed during transfer of NaK. A valve admits nitrogen, and a gage regulates the pressure. A drain valve is located on one end. Copper tubing is connected to the valve on the bottom of the NaK sump tanks and inserted through the opening into the transfer tank. This tubing is also held into the mineral oil. The sump tank valve is opened, and the NaK drains by gravity. The mineral oil floating on the NaK provides a seal. When the NaK has drained, the tubing is removed, the cover is replaced, and seven pounds of nitrogen pressure are sealed into the transfer tanks. The tanks may be stored temporarily or the NaK can be burned.

A small amount of NaK and NaK oxide remains in the generator and piping. The piping is dropped into a large tank of water, and the resulting reaction cleans the pipe thoroughly. The water becomes a dilute solution of sodium hydroxide, which is a caustic, and care must be taken in removing the piping from the tank. A good rinsing will remove the hydroxide, and then the pipe is dried, preferably in an oven, and is then ready for installation.

The generator is then disassembled, and the rotor is removed. The stator must now be cleaned to remove the remaining NaK and NaK oxide that coats the inner passages. The firemen spray water into all the openings until all traces of the NaK are removed. This is a very violent cleaning job, and safety procedures are followed to protect personnel and equipment in the immediate area. Large volumes of toxic smoke and flame result when the water reacts with NaK. The stator is next cleaned and then baked in an oven at 210°F for 16 hours to remove the moisture and to obtain the necessary insulation values.

9.2 REASSEMBLY

Reassembly of the generator involves no safety hazards. The prime consideration is insuring that clearances are maintained, and the insulation is good. A 100-volt megger is used at each step. After the generator assembly is completed, it must be aligned and balanced in the drive group. At this time the new NaK is put in, and the generator is ready for calibration.

9.3 NaK OXIDATION

Before putting NaK into the generator, nitrogen is forced into all passages and allowed to escape through open ports. This purging is designed to replace all air trapped in the generator with dry inert nitrogen. NaK will oxidize easily with even a small percentage of air in the system. Oxidation of the NaK is harmful because it

- (1) clogs passageways and restricts NaK flow, and it
- (2) becomes a contaminant and changes the characteristics of the NaK.

The oxide is finally deposited in the sump tanks. Its appearance is grey to black. Usually an amount of nitrogen is trapped in the pile which helps to make the substance light enough to float. Gradually the oxide will also accumulate in the pipes and fittings until adequate flow of NaK to the collectors is no longer possible. An overhaul is required to clean the system.

All piping must be tight to prevent loss of nitrogen and also inleakage of air. Tapered tubing fittings have been used with a pipe sealer. The nitrogen use rate is monitored daily to detect any leaks.

10.0 RESULTS

The power supply has been operated since December 22, 1956, to drive either the 50-in. Hypervelocity Tunnel (HS-2) or the electric gun. A resumé of the performance is as follows:

1. Over 1200 runs have been made, not counting numerous calibration operations.
2. The maximum current to date is 176,000 amperes.

3. The maximum stored energy is 4.46×10^6 joules.
4. The nominal arc chamber voltage is 2500 to 3000 volts.
5. The nominal arc resistance is 0.02 ohms.
6. Maximum insulation level at present is 10,000 volts.

To accomplish these results, several significant components have been under continual development. The more important of these have been NaK collector design, circuit breaker pole design, switching techniques, insulation improvements, and arc chamber design.

11.0 CONCLUDING REMARKS

Inductive power supplies can be adapted to drive hotshot tunnels at substantial savings in installed cost for large amounts of stored energy. However, fairly long arc durations, caused by the low values of arc impedance are characteristic. The discharge time can be controlled by the addition of an arc shorting switch. By presetting the mechanical timing it is possible to extinguish the arc at a desired time from five milliseconds and up. The load demands are so small that this type of supply can be built almost anywhere without considering the power system capacity, power schedules, or other limits normally encountered in locating large testing facilities.

REFERENCES

1. Early, H. C. and Walker, R. C. "Economics of Multimillion-Joule Inductive Energy Storage." Transactions of the AIEE, Vol. 76, Part 1, No. 31, July 1957, pp. 320-324.
2. Lukasiewicz, J., Jackson, R., and van der Blik, J. A. "Development of Capacitance and Inductive Driven Hotshot Tunnels." AEDC-TN-60-222, January 1961, p. 7.
3. Boyajian, Aram. "The D-C Motor as a Capacitor." Electrical Engineering, Vol. 72, No. 2, February 1953, pp. 154-155.
4. Kerchner, R. M. and Corcoran, G. F. Alternating-Current Circuits. November 1956, pp. 565-566, John Wiley and Sons, Inc., New York. (Third Edition).

5. Treible, J. "Unipolar Generators." Marquette Engineer,
April 1955, pp. 1-8.
6. Jackson, Carey B., Editor-in-Chief. Liquid Metals Handbook,
Sodium-NaK Supplement. TID 5227, July 1, 1955, AEC,
Navy Department, Washington, D. C.

APPENDIX I

HISTORY OF SYSTEM DEVELOPMENT

Hotshot 2 power supply has gone through numerous component changes since its initial operation in October 1956 because of various delays in procuring the various system components, inadequacies which were discovered in operation, and the urgency to have an operating tunnel at the earliest possible date (Figs. 18 and 19).

Some of the major items of interest in the development are listed with a short discussion of each.

COILS

Two temporary storage coils (Fig. 20) were made to begin operation. They had an inductance of approximately 406 microhenries and were cast in concrete. These were replaced by the present permanent coil having an inductance of 340 microhenries with an additional 30 microhenries in the generator and bus.

FLYWHEEL

The sectionalized flywheel as furnished had a very high noise level at the higher speeds, which was caused by protruding assembly bolt heads and handling holes drilled into the wheels. The bolt heads were countersunk, and the handling holes were plugged, greatly reducing the noise level. Modifications to the pedestal were made to increase the insulation level to 8000 volts.

BUS

A bus of suitable cross section, adequately braced, was installed to accommodate the maximum anticipated current capability of the power supply which is 300,000 amp. The inductance of this circuit was designed to be additive to that of the coil to increase the storage capability. The discharge portion of the bus is coaxial to minimize forces due to very high currents. Because of insufficient information regarding the switching capabilities of commercial circuit breakers for this unusual type of operation, the discharge bus impedance proved to be excessive. The excessive impedance caused circuit breaker damage. This situation was improved during the April 1959, generator shutdown.

MAGNETIC CLUTCH

The initial magnetic clutch furnished with the power supply was sized for the unipolar generator alone. Because of several failures with this clutch and the addition of the flywheel, a larger unit was obtained, installed, and operated successfully. To furnish adequate cooling for the new clutch, a booster pump was incorporated in the water system.

Since the coasting down time of the power supply was in excess of one hour, a procedure with associated equipment for reversing and braking with the drive motor was incorporated. Braking time was reduced to 11 minutes with maximum flywheel load.

INSULATION

During the initial stages of the 50-in. Hypervelocity Tunnel (HS-2) operation, the generator (although insulated for 600 volts to ground) and the flywheel were essentially grounded. The arc chamber was adequately insulated from ground. However, during high vacuum (1μ Hg up to 100μ Hg) operation, the insulation between the arc chamber and the tunnel broke down because of surface creepage; thus, one good ground was present, and low insulation existed at the generator. During the arc discharge, high voltage would jump the generator insulation, providing a completed ground path. This path was capable of extensive damage to the system components such as welding of the arc chamber, bearings, hold-down bolts, and occasionally the power supply instrumentation. Attempts were made to increase the insulation values to prevent this damage. The upper limit was 5000 volts on the generator unless drastic and expensive modifications were made (Fig. 16).

Several studies were made of this situation, and it was decided to ground the arc chamber and the generator negative terminal and housing; thus the need for insulation was eliminated. The high voltage can now appear only between one terminal of the energy storage coil and the arc chamber positive terminal. This portion of the bus has been insulated for 10 to 20 kv.

CURRENT SOURCE

Early in the history of the power supply development, the main current source was derived from a temporary selenium rectifier bank (Fig. 20). A maximum current of 40,000 amp, obtainable from this system, was far below the projected requirements for the 50-in. Hypervelocity Tunnel. It did provide valuable experience in developing techniques for switching, timing, fusing and for general familiarization with inductive power supplies.

UNIPOLAR GENERATOR

The high-current, low-voltage, unipolar generator required considerable development to reach its present capacity of 176,000 amperes actual, but predicted, capacity of 250,000 amperes. The principal modifications required were two redesigns of the current collector rings that contain the NaK (Fig. 21). Additional modifications were made to the NaK and nitrogen piping to simplify assembly and disassembly during the required periodic overhauls for cleaning and inspecting the generator.

TRANSFER SWITCHES

A number of transfer switches were used during the course of the power supply development. In chronological order, these were:

1. 600 amp, 600 v, a-c
2. 1200 amp, 15 kv, a-c, magneblast
3. 10,000 amp, 750 v, d-c (Fig. 22)
4. 4,000 amp, 15 kv, a-c, airblast (Fig. 11)

The breaker (4), after arc contact modification (Fig. 12), was found to perform satisfactorily up to the present current level.

POWER SUPPLY OPERATION

The evolution of the power supply is shown schematically in Fig. 18. These circuits and components were actually installed and used. External fuses across the load were used in an effort to increase the performance of the available switches. No particular conclusions were drawn as to their ultimate performance since the modified type breaker and lower impedance discharge bus are presently satisfactory. Further increases in current levels may require additional work in this area.

TIMING STUDIES

During the various stages of development of the power supply circuitry, a number of timing studies were made. These studies included determination of the following times:

1. current buildup
2. commutation
3. switch operation
4. fuse breakdown and
5. arc duration.

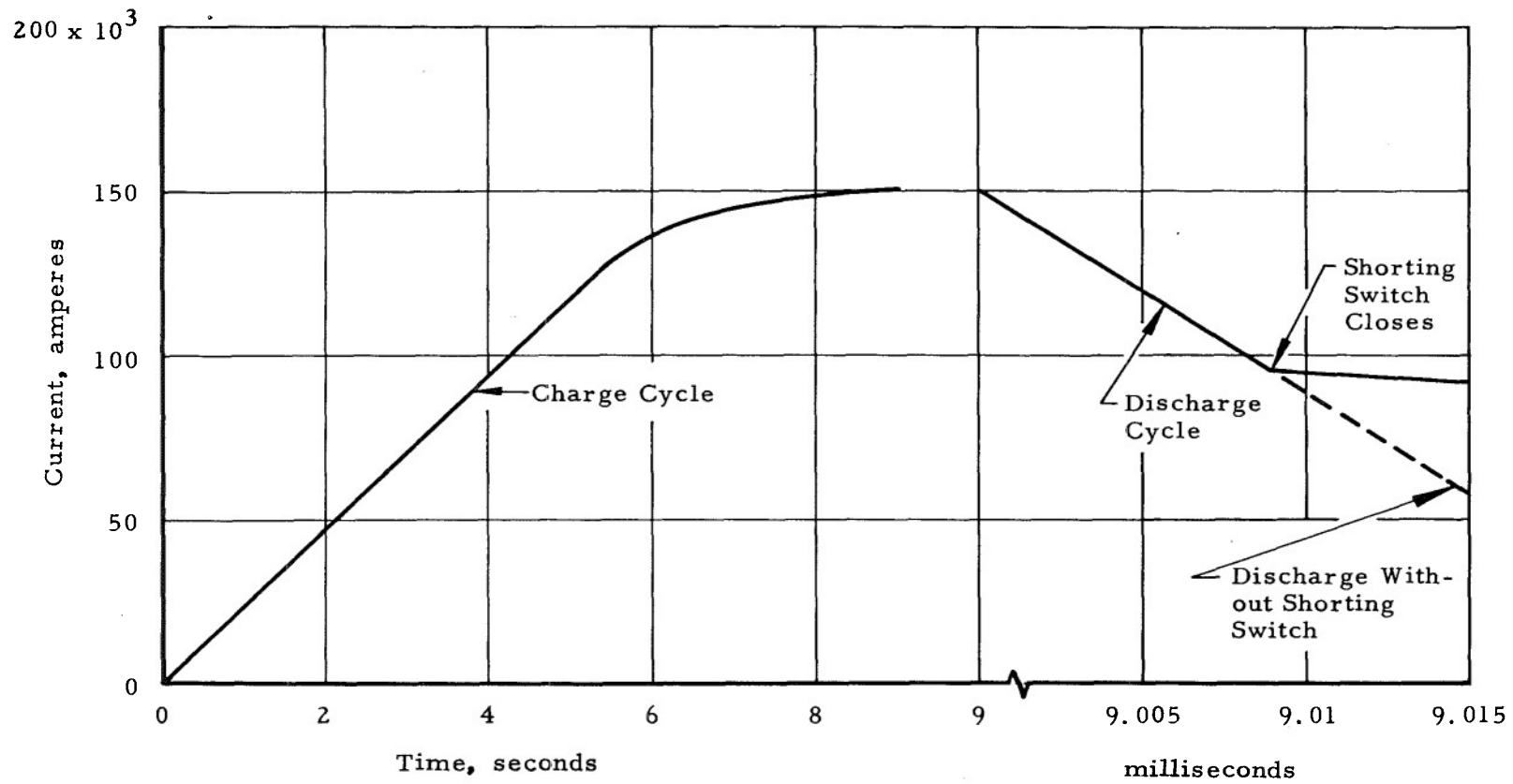

Fig. 1 Curve of Buildup and Decay of Current

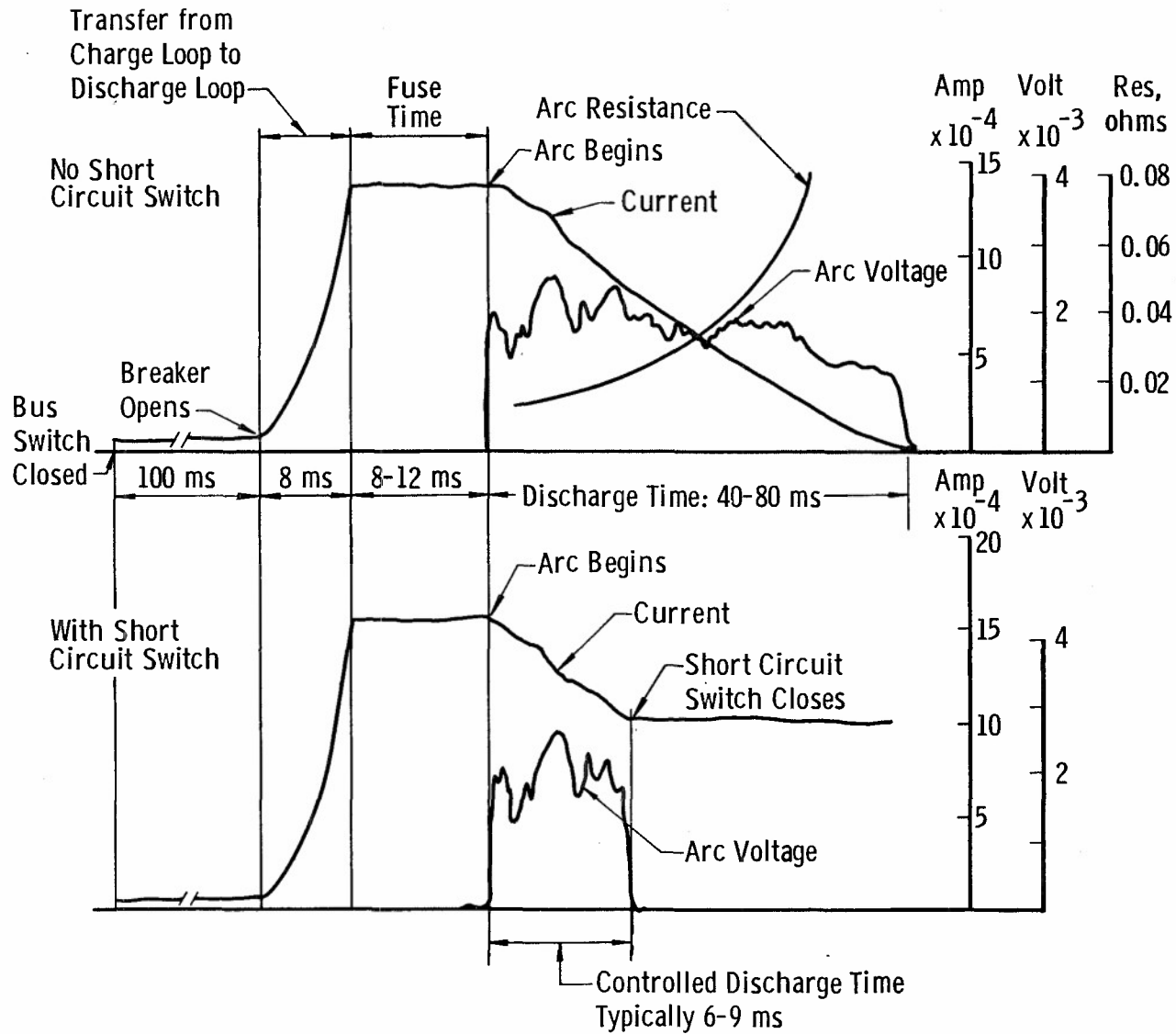

Fig. 2 Typical Current, Voltage, and Resistance Traces with and without Short Circuit Switch

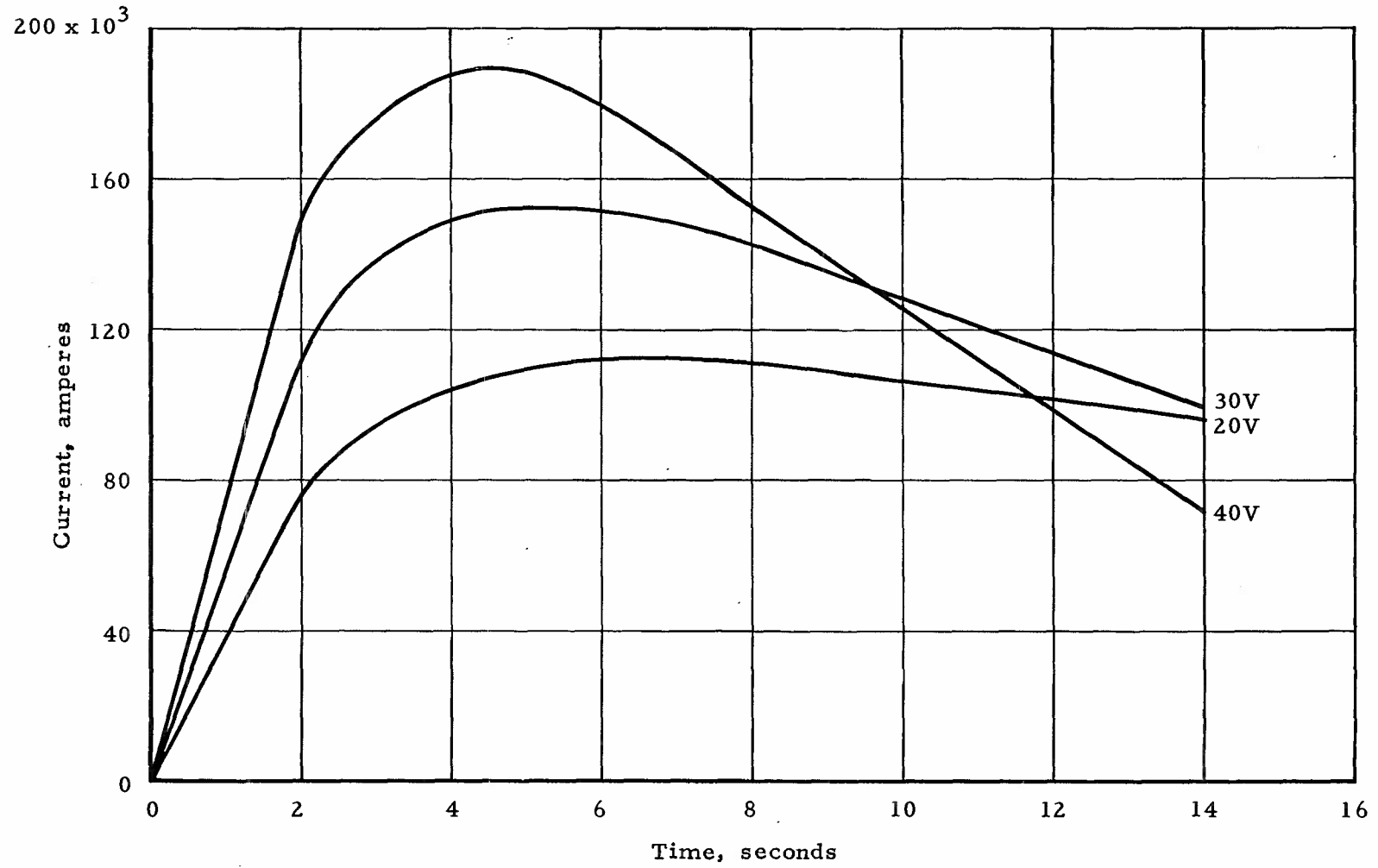

Fig. 3 Calculated Generator Performance

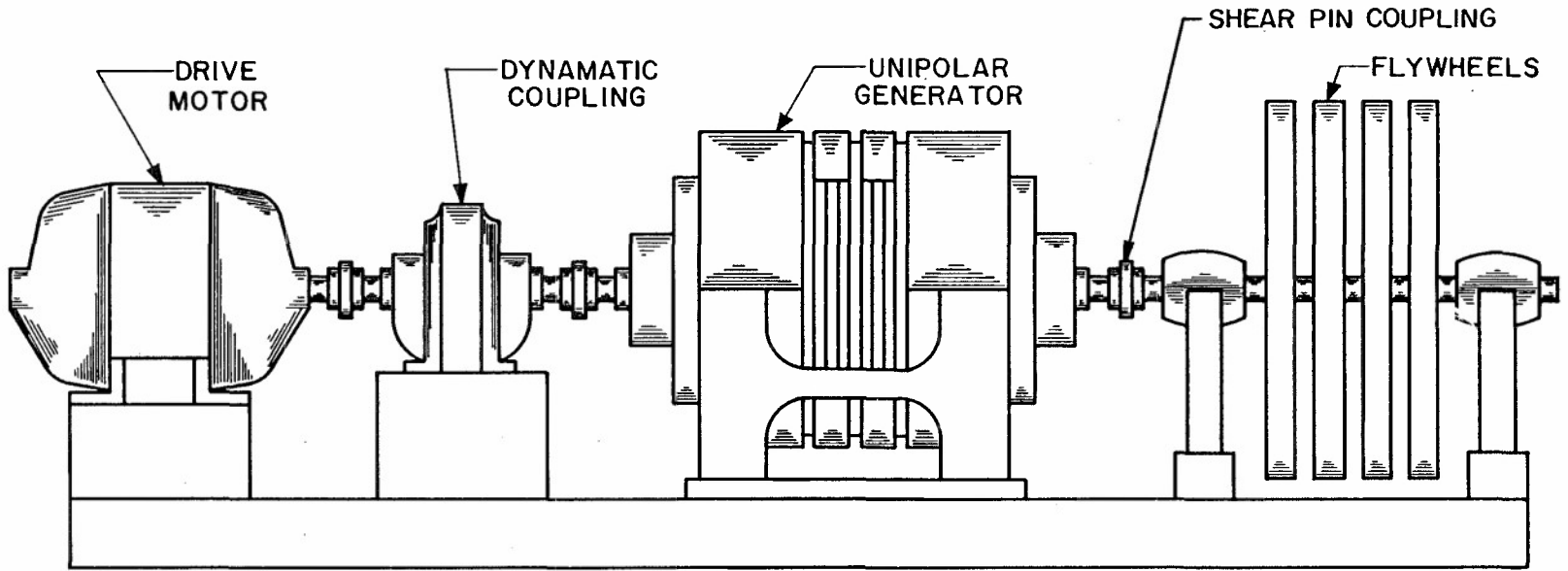

Fig. 4 Unipolar Generator Drive Unit

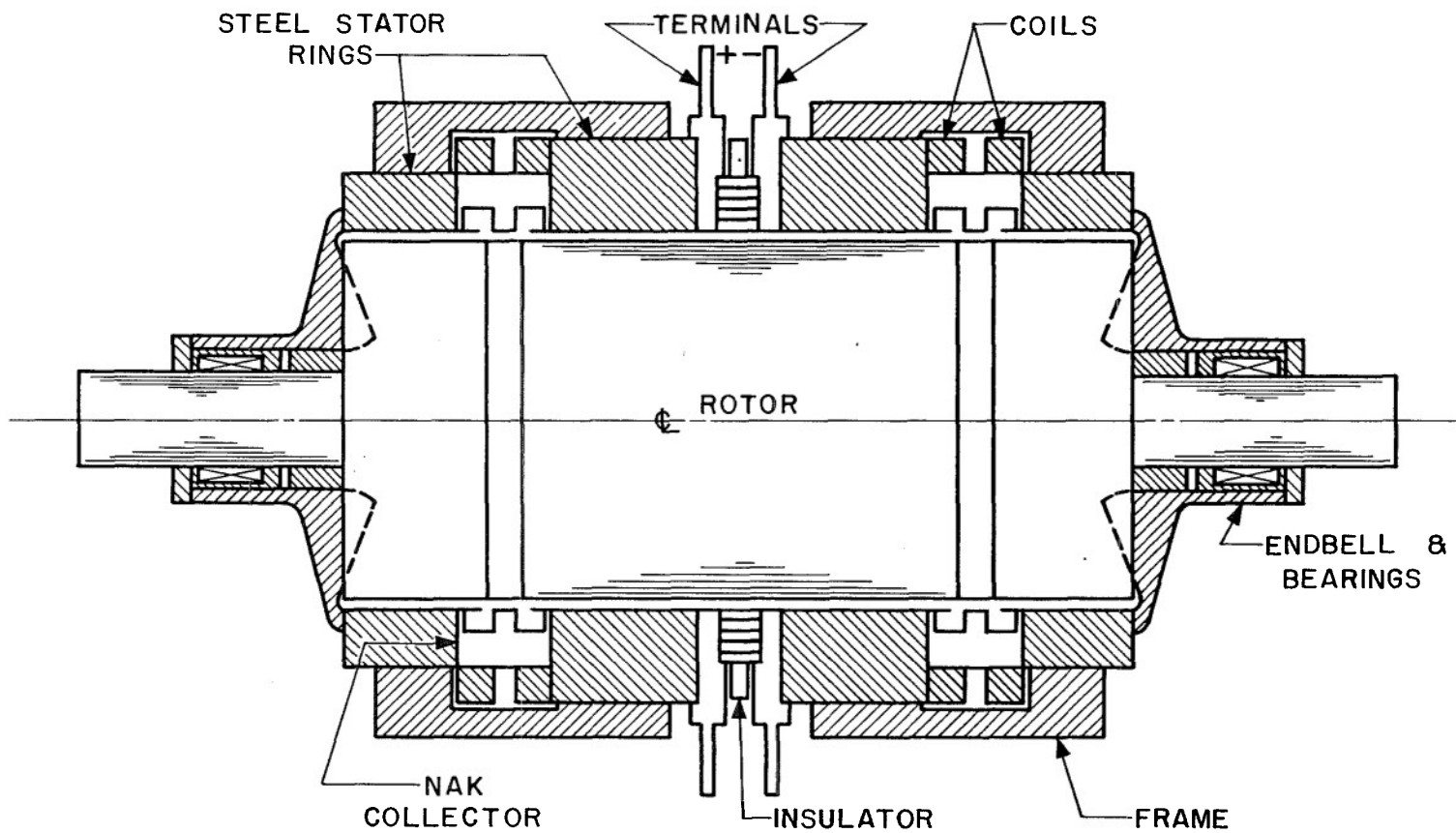

Fig. 5 Cross Section - Unipolar Generator

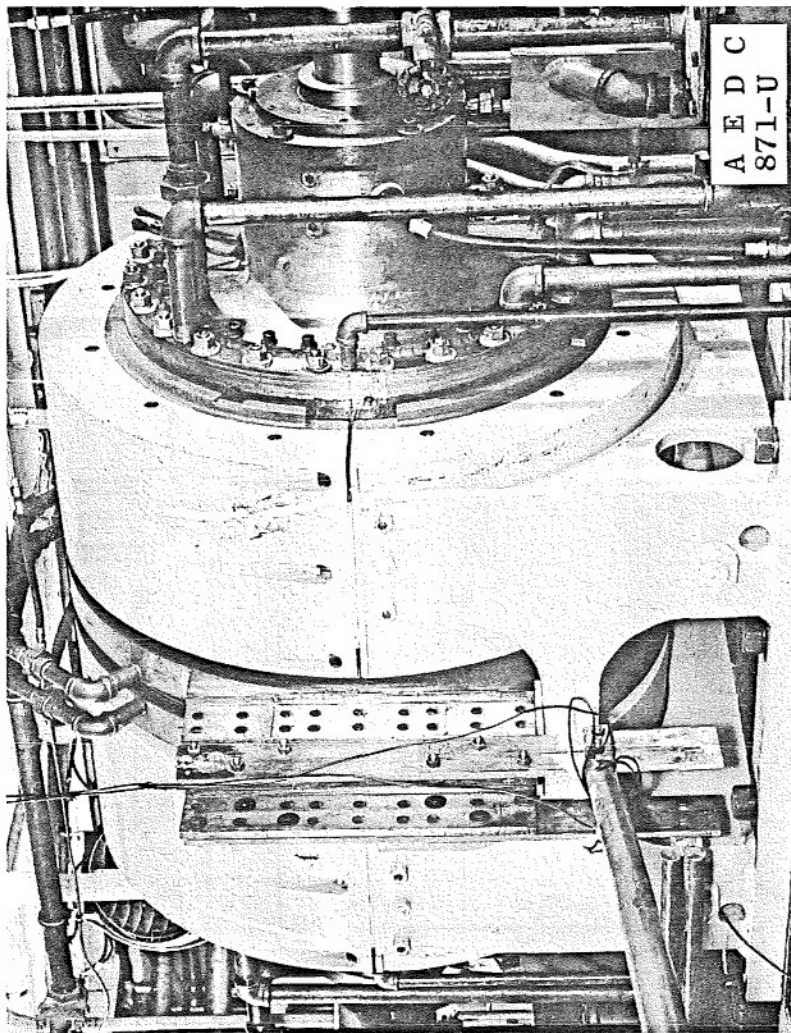

Fig. 6 Unipolar Generator

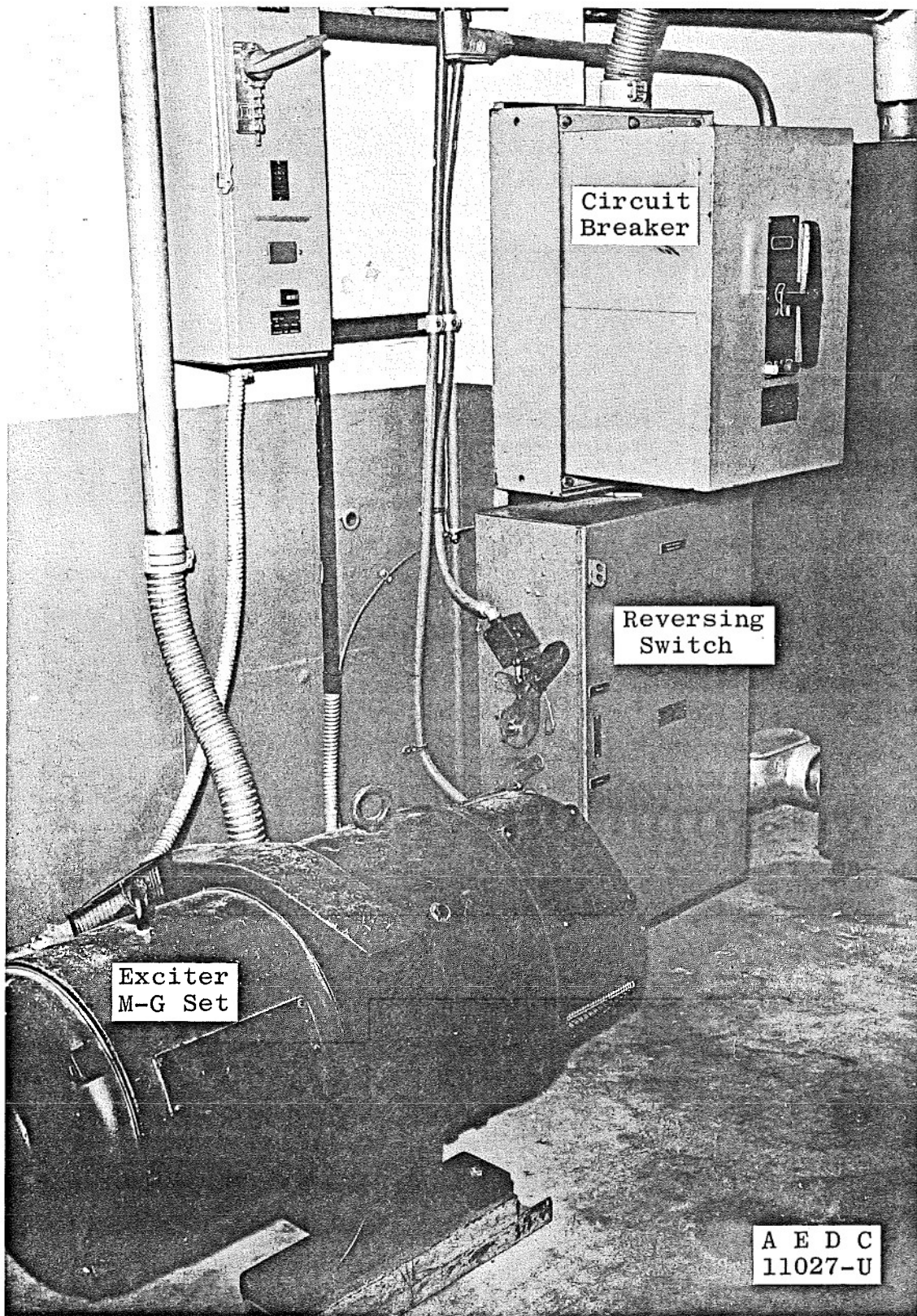

Fig. 7 M-G Exciter and Electrical Equipment

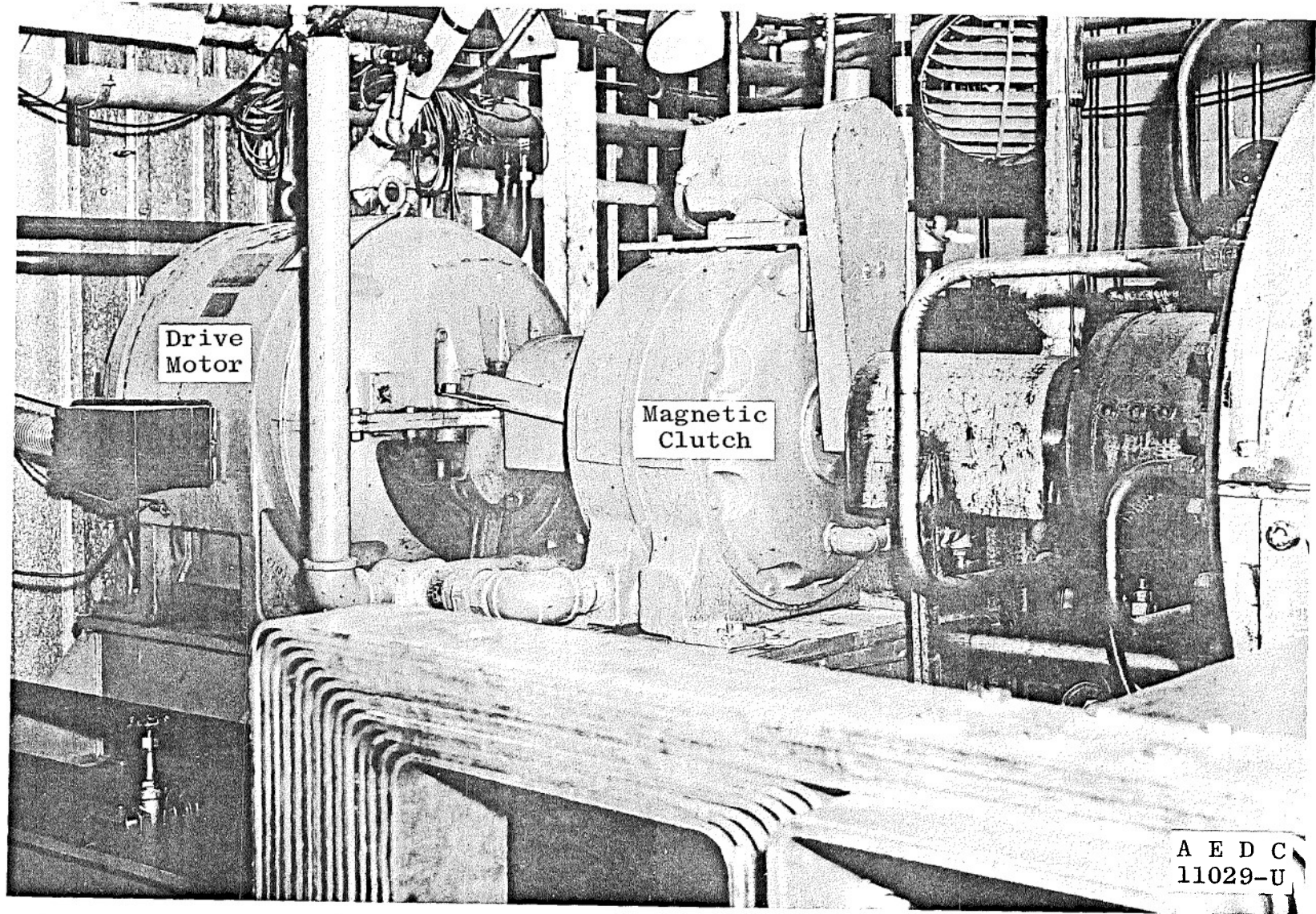

Fig. 8 Drive Motor and Magnetic Clutch

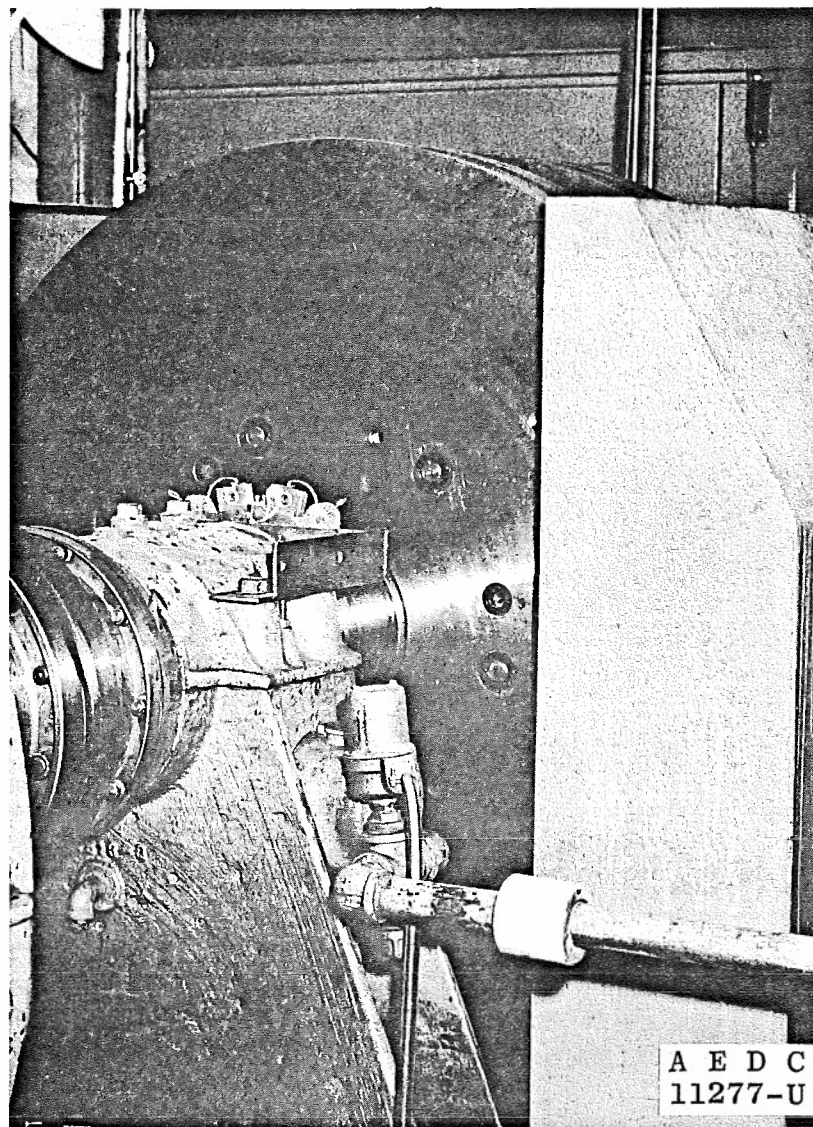

Fig. 9 Flywheel and Koppers Shear-Pin Coupling

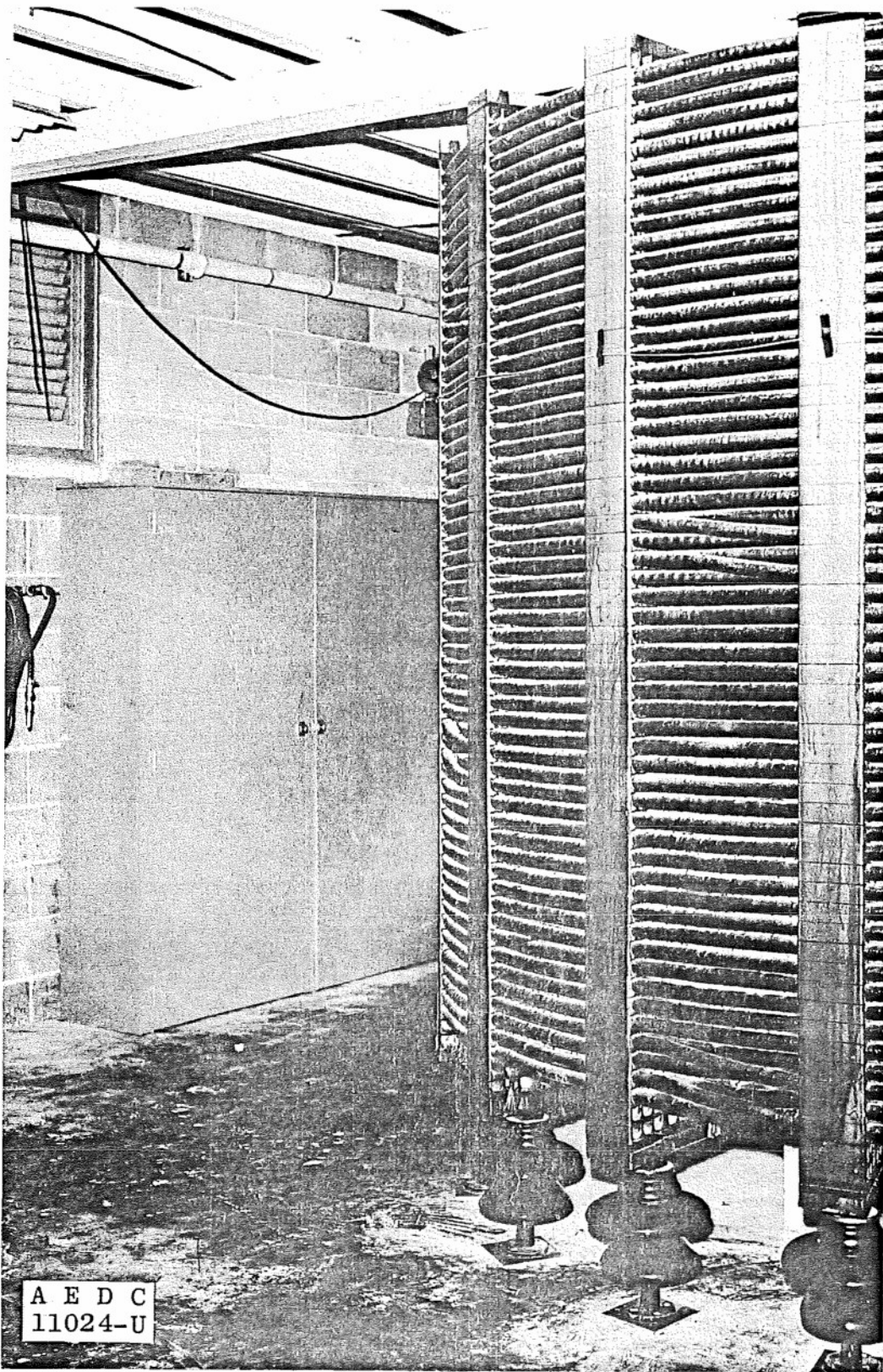

Fig. 10 Magnetic Energy Storage Coil

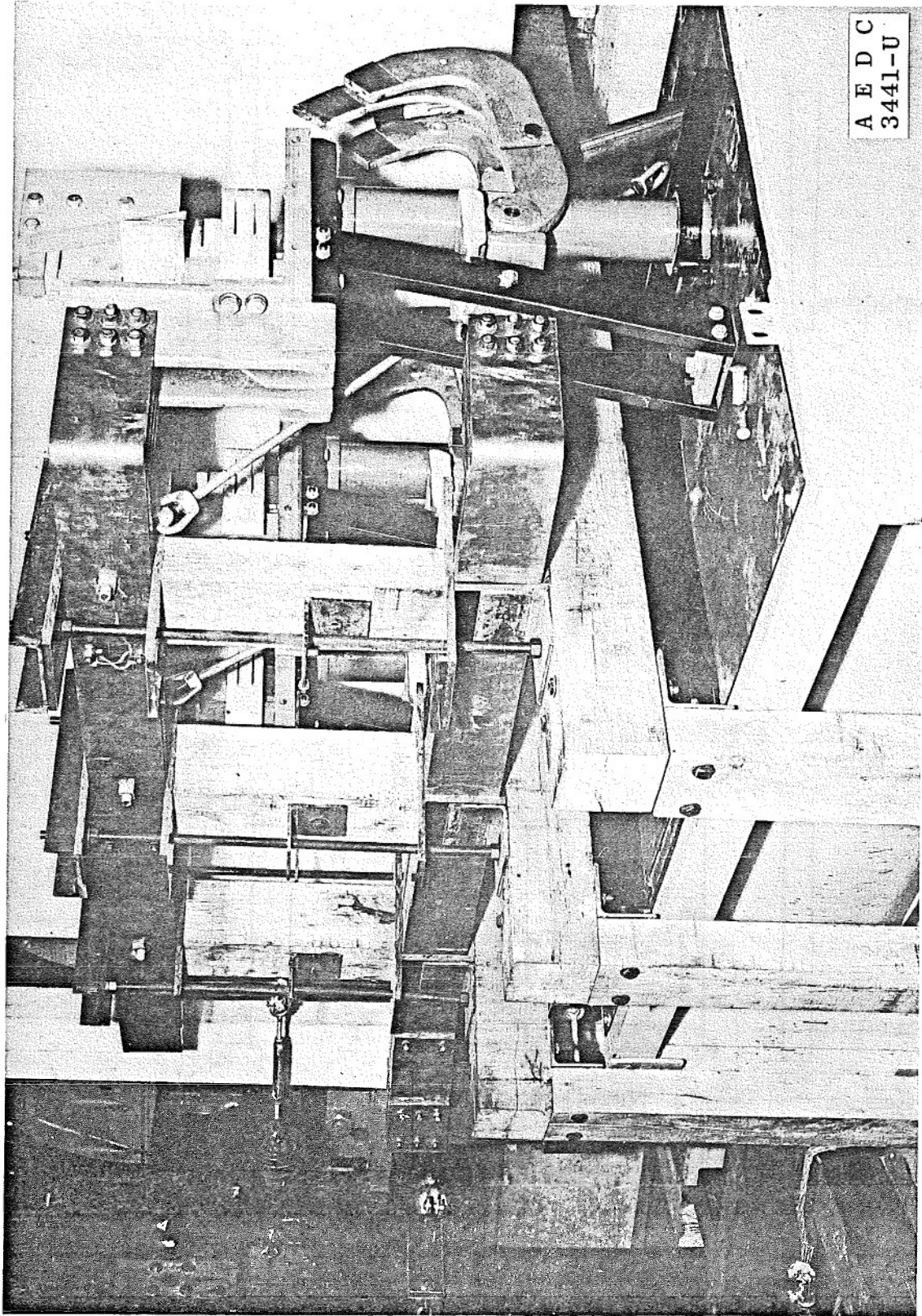
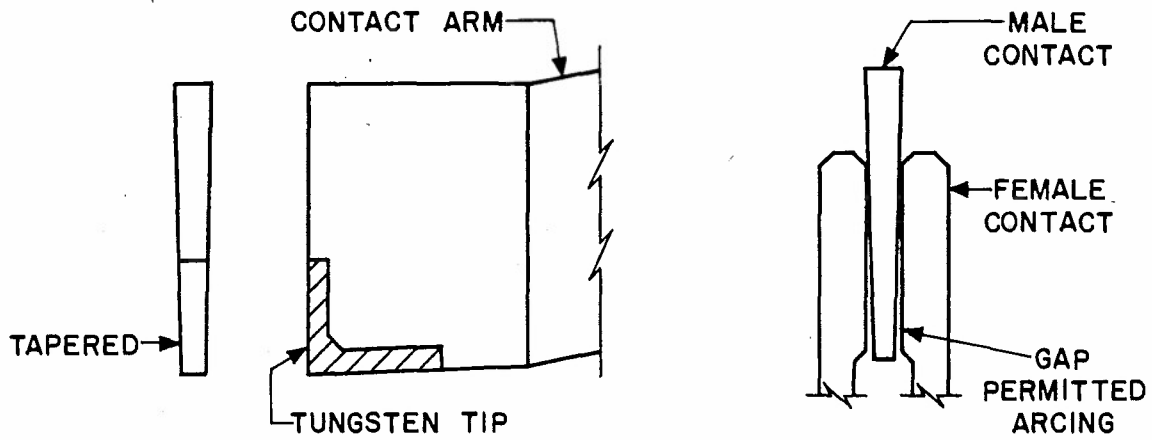
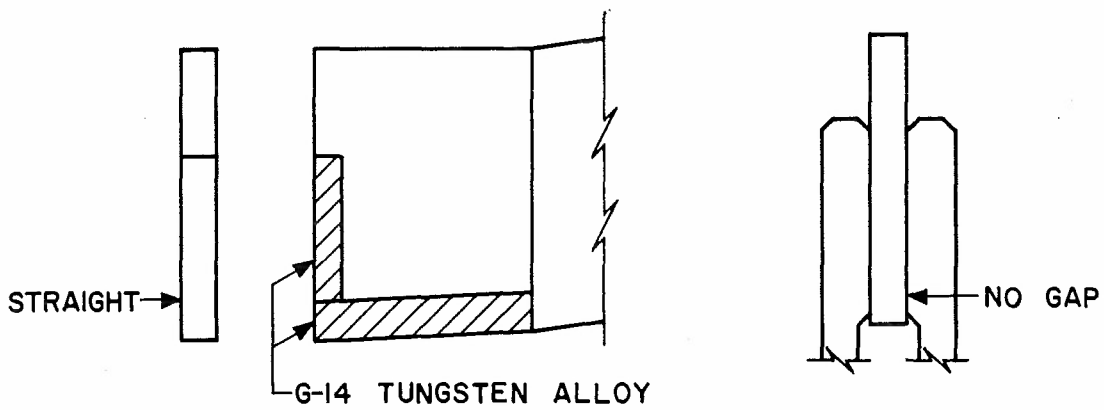

Fig. 11 S-1 CA Breaker



ORIGINAL EQUIPMENT



MODIFIED EQUIPMENT

Fig. 12 Brecker Contact Modification

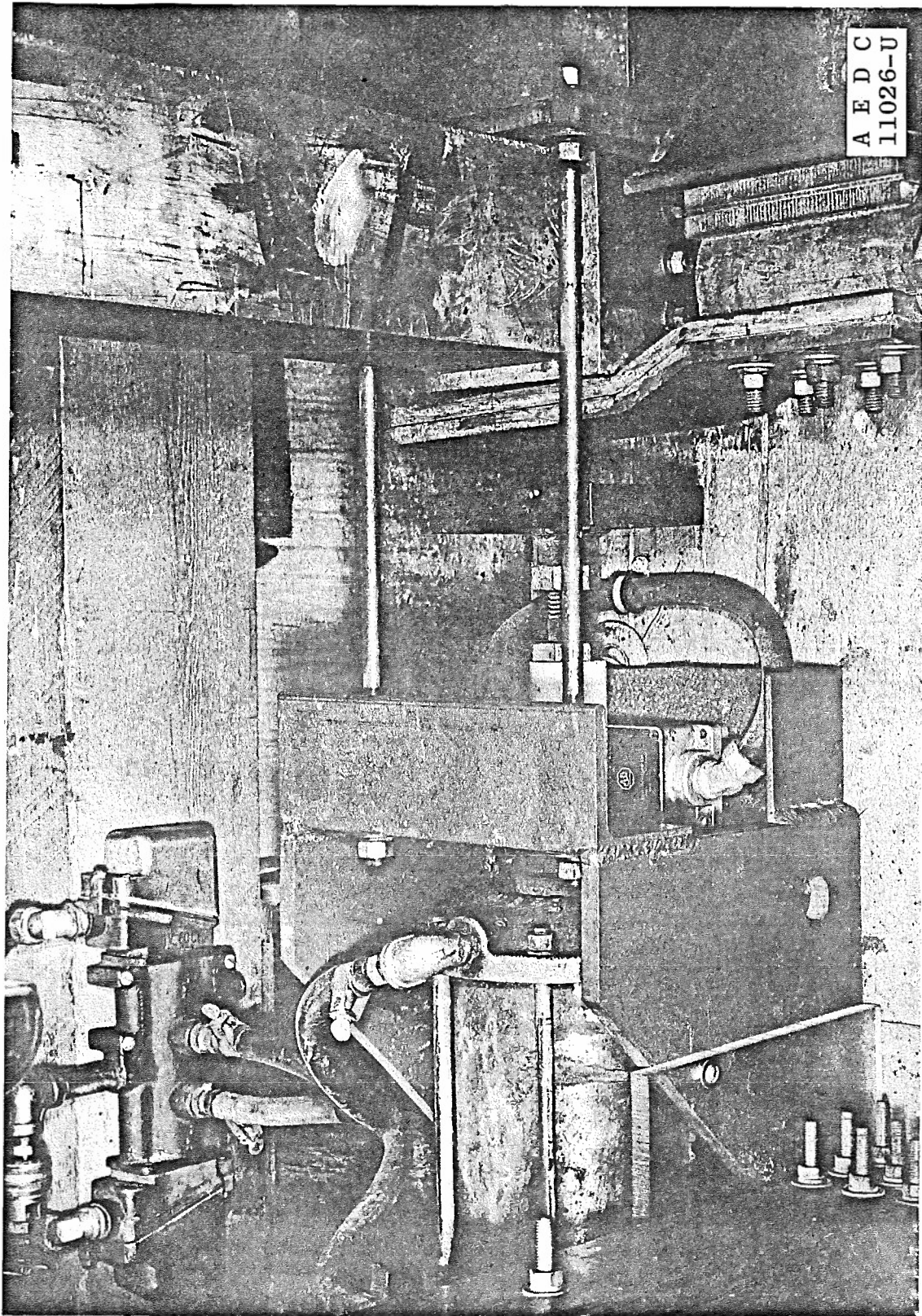

Fig. 13 S-2 Switch

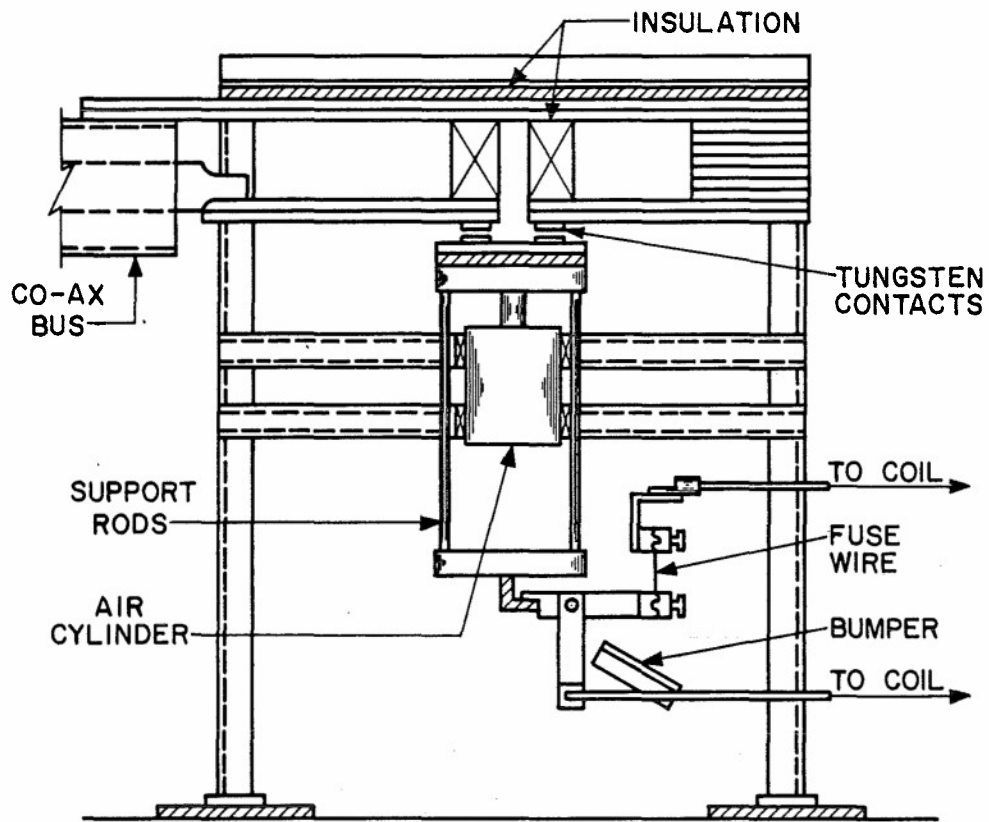

Fig. 14 Shorting Switch

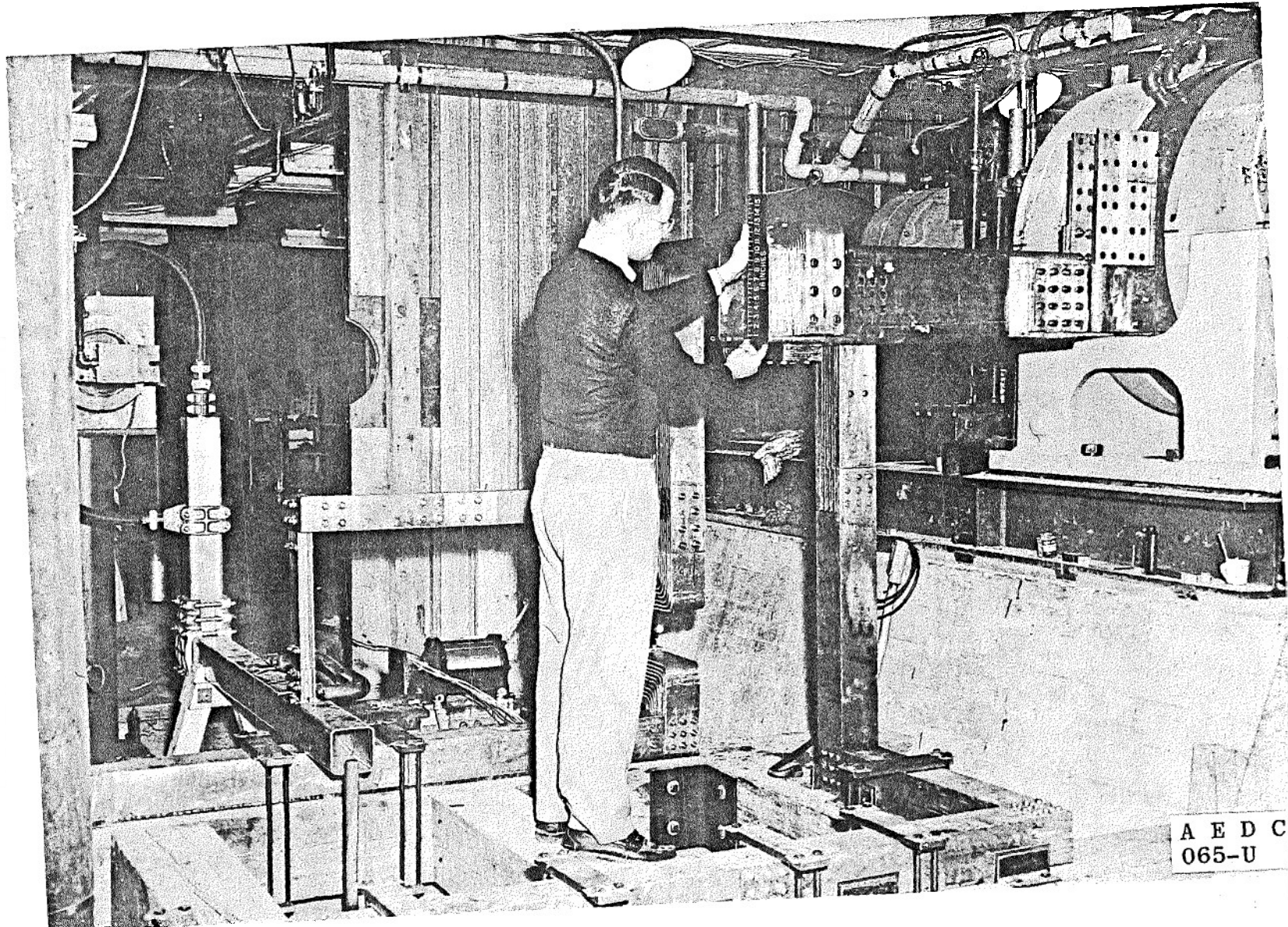

Fig. 15 Bus

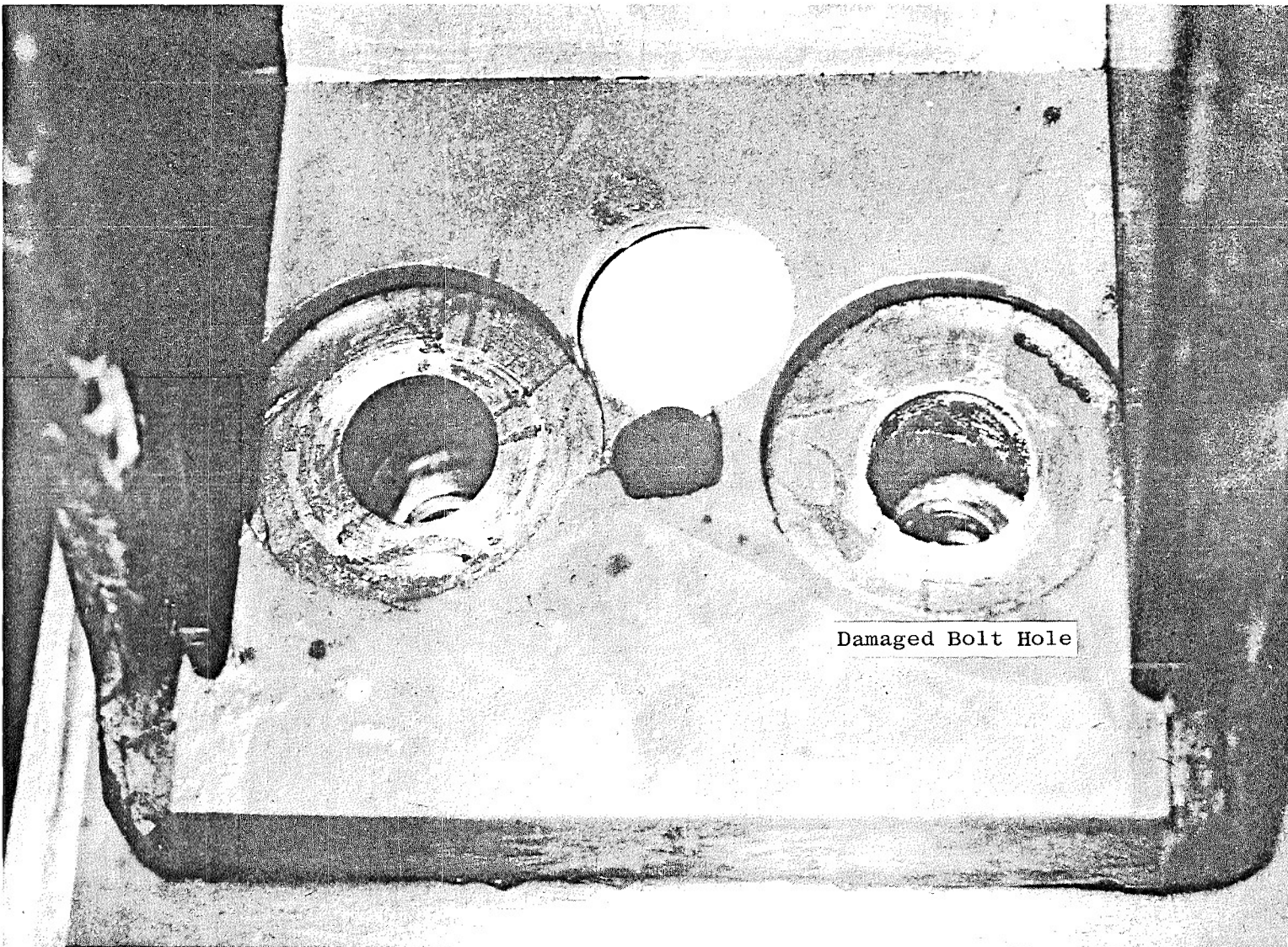

Fig. 16 Flywheel Insulation Damage

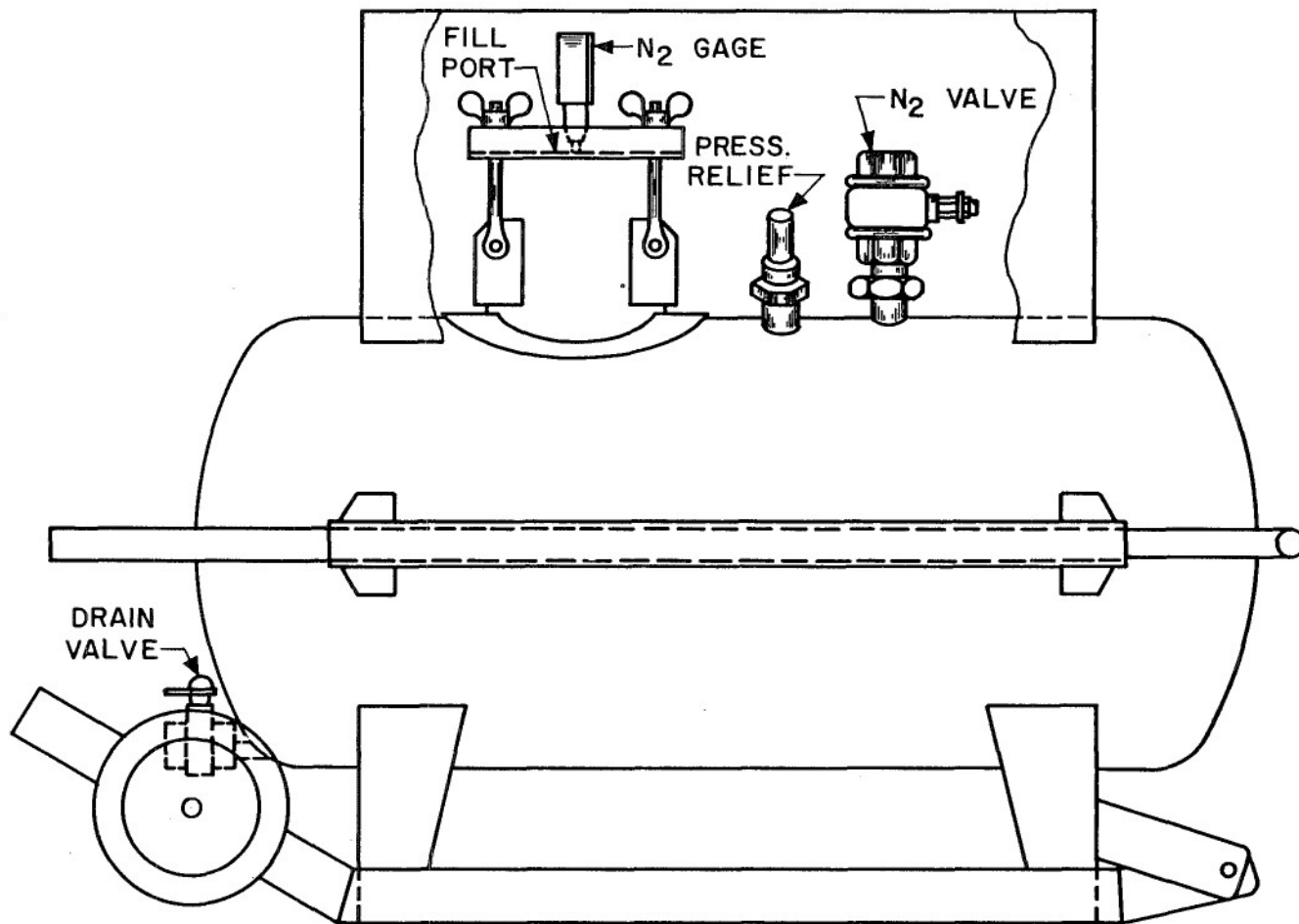
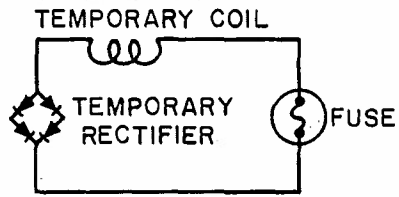
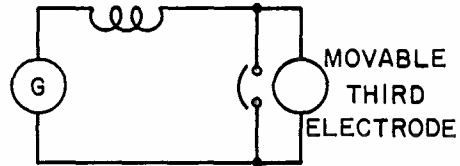

Fig. 17 NaK Transfer Tank

(1) SPRING 1956



(6) SPRING 1957



(2) SUMMER 1956

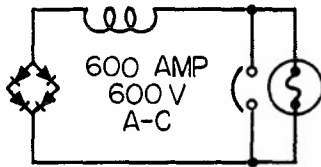

(7) SUMMER 1957

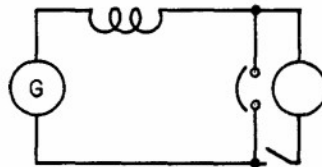

(3) SUMMER 1956

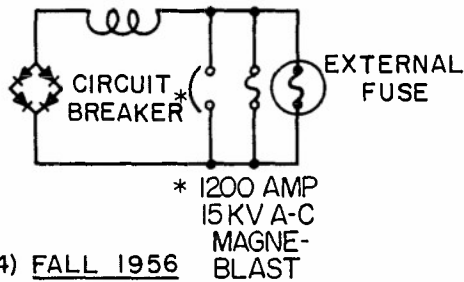

(8) JANUARY 1958

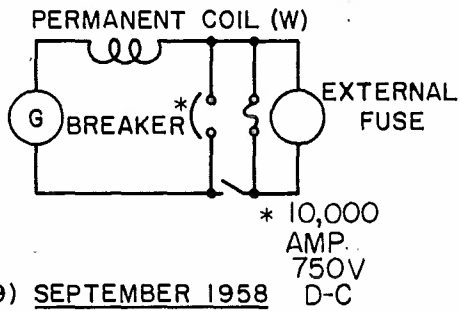

(4) FALL 1956

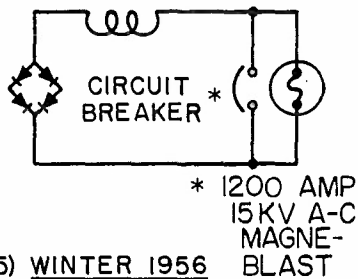

(9) SEPTEMBER 1958

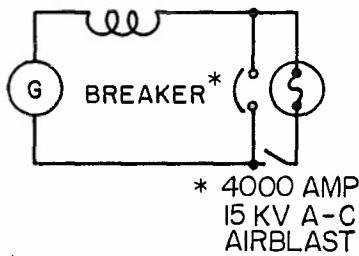

(5) WINTER 1956

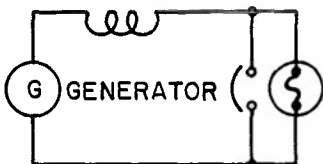

(10) SUMMER 1961

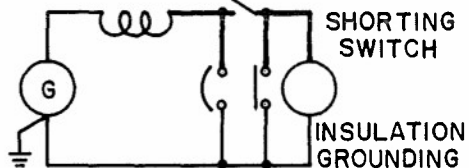

Fig. 18 Schematics of Circuits Used in 50" Hypervelocity Tunnel Development

<u>CONFIGURATION</u>	<u>CURRENT SOURCE</u>	<u>COIL</u>	<u>CHARGE LOOP SWITCH</u>	<u>LOAD</u>	<u>CHARGE LOOP SWITCH</u>	<u>CURRENT (AMPS)</u>	<u>ENERGY (JOULES)</u>
1. Spring, 1956	Rectifier/Transformer	AEDC	Fuse	Fuse in A/C	---	8,500	45,100
2. Summer, 1956	Rectifier/Transformer	AEDC	600 amp, 600 v, a-c	Fuse in A/C	---	8,500	45,100
3. Summer, 1956	Rectifier/Transformer	AEDC	1200 amp, 15 kv, a-c, magneblast	Fuse in A/C	Ext. Fuse	18,000	37,260
4. Fall, 1956	Rectifier/Transformer	AEDC	"	Fuse in A/C	Ext. Fuse	40,000	92,000
5. Fall, 1956	Unipolar Generator	AEDC	"	Fuse in A/C	Ext. Fuse	40,000	92,000
6. Spring, 1957	Unipolar Generator	AEDC	"	3rd Electrode in A/C	---	120,000	1,105,000
7. Summer, 1957	Unipolar & Flywheel	AEDC	"	3rd Electrode in A/C	Bus Switch	47,000	460,000
8. January, 1958	Unipolar & Flywheel	Westing- house	10,000 amp, 750 v, d-c	3rd Electrode in A/C	Bus Switch & Fuse	124,000	610,000
9. September, 1958	Unipolar & Flywheel	Westing- house	4,000 amp, 15 kv, a-c, airblast	3rd Electrode in A/C	Bus Switch & Fuse	145,000	3,580,000
10. November, 1958	Unipolar & Flywheel	Westing- house	"	Fuse in A/C	Bus Switch	146,200	3,650,000
11. January, 1961	Unipolar & Flywheel	Westing- house	"	Fuse in A/C + Shorting Switch	Bus Switch	162,000	4,460,000

Fig. 19 Resumé of Performance of Stages of 50" Hypervelocity Tunnel Development

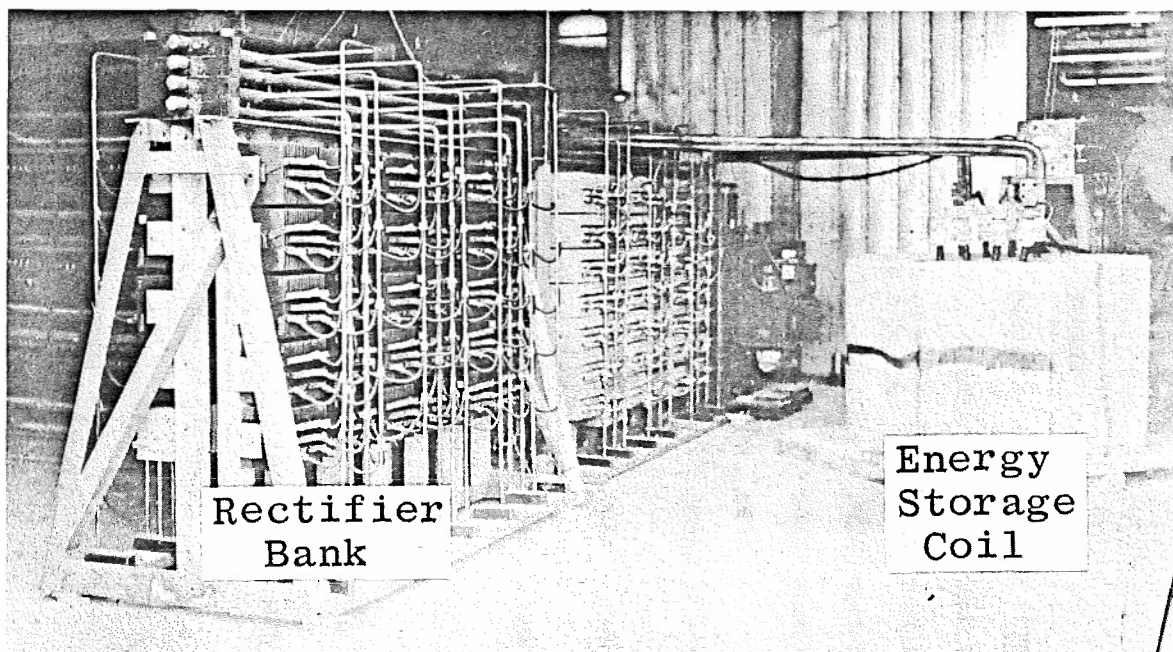

Fig. 20 Selenium Rectifier and Temporary Coil

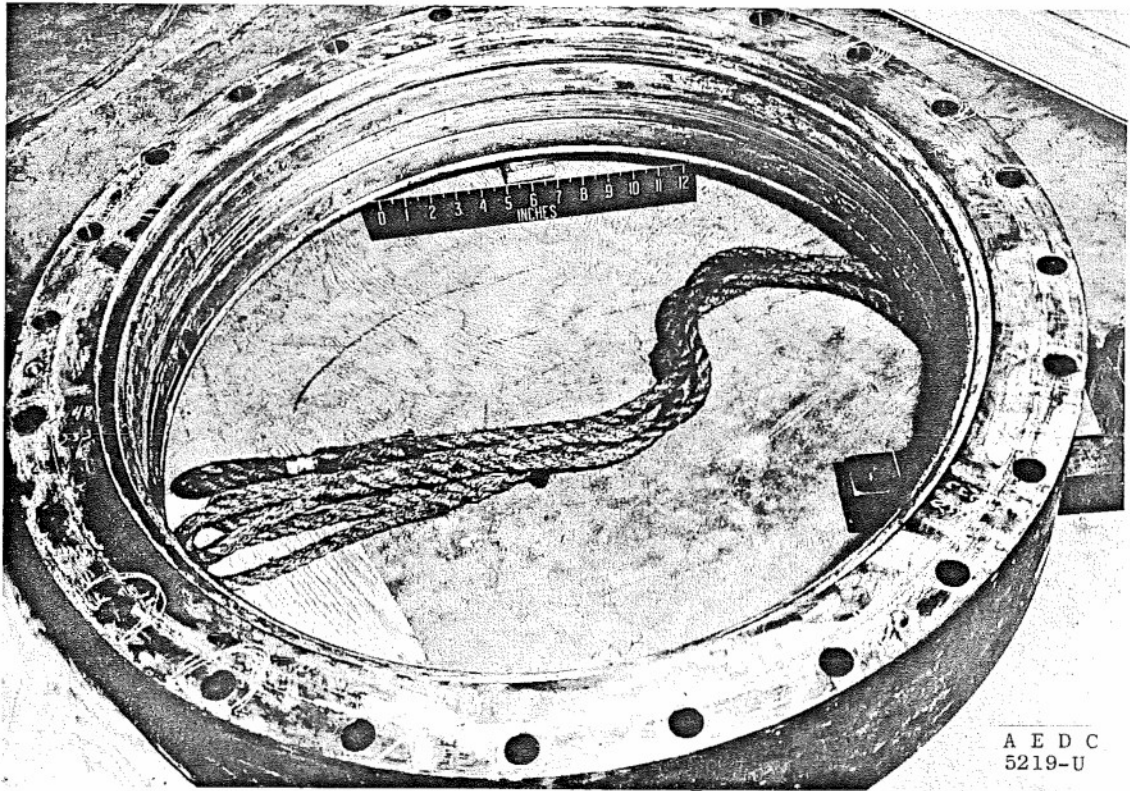

Fig. 21 Collector

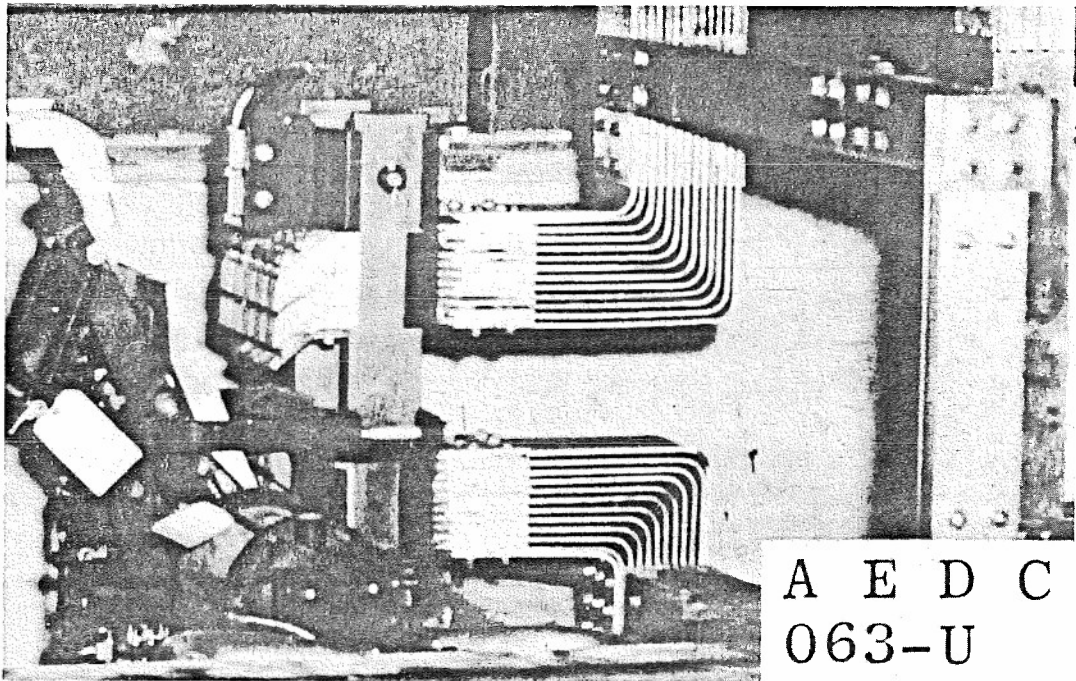

Fig. 22 Breaker