

UNCLASSIFIED

AD NUMBER
AD280189
NEW LIMITATION CHANGE
TO Approved for public release, distribution unlimited
FROM Distribution authorized to U.S. Gov't. agencies and their contractors; Foreign Government Information; APR 1961. Other requests shall be referred to British Embassy, 3100 Massachusetts Avenue, NW, Washington, DC 20008.
AUTHORITY
DSTL, AVIA 10/536, 13 Aug 2008

THIS PAGE IS UNCLASSIFIED

UNCLASSIFIED

AD 280 189

*Reproduced
by the*

**ARMED SERVICES TECHNICAL INFORMATION AGENCY
ARLINGTON HALL STATION
ARLINGTON 12, VIRGINIA**



UNCLASSIFIED

NOTICE: When government or other drawings, specifications or other data are used for any purpose other than in connection with a definitely related government procurement operation, the U. S. Government thereby incurs no responsibility, nor any obligation whatsoever; and the fact that the Government may have formulated, furnished, or in any way supplied the said drawings, specifications, or other data is not to be regarded by implication or otherwise as in any manner licensing the holder or any other person or corporation, or conveying any rights or permission to manufacture, use or sell any patented invention that may in any way be related thereto.

280 189

7

AD 100-600-50

FILE COPY

**STRENGTH AND STIFFNESS TESTS ON
MULTI-WEB BOXES IN STEEL AND
TITANIUM AT ELEVATED TEMPERATURES**

**REPORT OF WORK CARRIED OUT BY SAUNDERS-ROE
LIMITED UNDER MINISTRY OF AVIATION
CONTRACT No. 6/AIRCRAFT/11020/CB.7(b)**

THE RECIPIENT IS WARNED THAT INFORMATION
CONTAINED IN THIS DOCUMENT MAY BE SUBJECT
TO PRIVATELY-OWNED RIGHTS.

**ISSUED
APRIL 1961
BY
TECHNICAL INFORMATION AND LIBRARY SERVICES
MINISTRY OF AVIATION**

UNCLASSIFIED

ASTIA
APR 24 1962
TISIA

S & T Memo 3/61

STRENGTH AND STIFFNESS TESTS ON MULTI-WEB BOXES
IN STEEL AND TITANIUM AT ELEVATED TEMPERATURES.

Part I - Tests

Part II - Analysis

Strength and Stiffness Tests on Multi-Web
Boxes in Steel and Titanium at Elevated Temperatures.

SUMMARY

The report contains the results of a theoretical and experimental study of the pure bending strength and torsional stiffness of stainless steel (D.T.D.166 and Firth Vickers 520) and titanium alloy (I.C.I.317) box beams. This research forms a continuation of the work already carried out on aluminium boxes at ambient temperatures reported in S & T Memo 1/61. The new work has formed an extension of the original Ministry of Supply Contract No: 6/Aircraft/11020 CB.7(b).

Part I of the report covers, in full detail, the results of experimental work on a total of nine box-beams, three in each material. Each box was subjected to torsional stiffness tests and then broken in pure bending, these tests being carried out on identical boxes, in each material, at ambient temperatures and at steady temperatures of 200°C and 300°C. In order to reduce costs the boxes were somewhat smaller than the aluminium alloy ones of the original programme and contained only three cells instead of the original five.

Part II of the report compares the experimental results with the same theories used in Part II of the original report S & T Memo 1/61. It is concluded that there is reasonably good agreement between the theory of pure bending failure of Reference 2 and the experimental results. The agreement is not so good at elevated temperatures as that in the original report, but this can be attributed to the greater scatter in experimental results which would be expected when temperature effects are introduced in addition to the applied loading. Good agreement is reported between simple torsion theory and the torsional stiffness measurements, the theoretical results being in the range +11% to -3% of the experimental results. It is noted, however, that the titanium alloy specimens show effective moduli of rigidity of about 1% less than would be expected in relation to their moduli of elasticity. This result was confirmed by material control tests carried out at the National Physical Laboratory. Thus the particular titanium alloy (I.C.I.317) used in the test is a relatively inefficient sheet material when used in an application where torsional stiffness is the design criterion.

**Strength and Stiffness Tests on Multi-Web Boxes
in Steel and Titanium at elevated temperatures.**

Part I - Tests.

PART I.I N D E X

	<u>Sheet No.</u>
1. Introduction	1
2. Test Programme	1
3. Description of Specimens	1
4. Description of Rigs	
4.1. Torsion Rig	2
4.2. Bending Rig	2
4.3. Heating System	2
5. Method of Test	3
6. Results	
6.1. Torsion Tests	4
6.2. Bending Tests	4
7. Control Specimens	5
8. Measured Modulus of Rigidity	5

LIST OF TABLES

A Temperature distribution over beams - Torsion	6
B Dial Gauge Deflections - Torsion	7 - 10
C Relative deflections over test length only - Torsion	11 - 12
D Overall dimensions of beams	13
E Calculated and experimental angle of twist of beams	14
F Temperature distribution over beams - bending	15
G Dial gauge deflections - Bending	16-18
H Maximum bending moments and failing stresses	19
J Summary of Control Test Results	20
K Measured Modulus of Rigidity by Ultrasonic method	21

LIST OF FIGURES

1 - 2 Titanium and Steel Box Beam Specimen	
3 - 5 Thermocouple positions for Box Beam	
6 Torsion Test Rig for Box Beams	
7 Bending Test Rig for Box Beams	
8 - 11 Dial Gauge positions for Box Beams (Torsion Tests)	
12-14 " " " " " " (Bending Tests)	
15-23 Chordwise relative deflections over test length (Torsion)	
24-32 Variation of angle of twist over test length (Torsion)	
33 Variation of strength and stiffness of Beams with temperature	
34-51 Mean deflections of specimens (Bending Tests)	
52-60 Deflections at centre relative to the inner supports (Bending)	
61-69 Beam curvature at 10,000 lb. (330,000 lb.ins. Bending Moment)	
70-75 Stress-Strain Curves for Control Specimens	
76-78 Variation of 'E' of Control Specimens with Temperature	

I N D E X (Contd.)LIST OF PLATES

1	Arrangement of Torsion Rig
2 - 3	" " Bending Rig
4	" " Lamp trays for Bending Tests
5	Beam No. 1 after failure
6	" " 2 " "
7	" " 3 " "
8	" " 4 " "
9	" " 5 " "
10	" " 6 " "
11	" " 7 " "
12	" " 8 " "
13	" " 9 " "

STRENGTH AND STIFFNESS TESTS ON MULTI-WEB BOXES
IN STEEL AND TITANIUM AT ELEVATED TEMPERATURES.

PART I. TESTS.

1. INTRODUCTION

In continuance of the research on Multi-Web Box construction the first part of which - Aluminium Alloy Boxes - has been covered by S & T Memo 1/61, it was decided to extend the Ministry of Supply Contract 6/Aircraft/11020/CB.7(b) to include tests to determine the effect of temperature on the strength and stiffness of boxes in steel and titanium. This report contains the results of these tests.

2. TEST PROGRAMME

For the purpose of the tests two representative steel alloys were selected - D.T.D.166 and Firth-Vickers F.V.520 - and a relatively high strength titanium alloy I.C.I.517. A torsional stiffness test followed by a bending test to failure were to be carried out on each specimen and three specimens in each material were required so that tests at normal ambient temperature, at 200°C and 300°C could be made.

3. DESCRIPTION OF SPECIMENS

The specimens were manufactured to Drawing No. 14716-9, and particulars of the main dimensions, plate gauges and riveting are given in Figs. 1 and 2. Each specimen consisted of a centre section and two outer sections which were common to all specimens.

The centre sections were basically composed of four formed channel section webs riveted to flat top and bottom sheets of equal thicknesses. Intercostal diaphragms were located in pairs at the load application sections and reinforcing flange angles were added to the webs outside of the test length. All sheet material was to the following specification:-

<u>Specimen No.</u>	<u>Specification</u>	<u>Drawing No.</u>
1 - 3	D.T.D.166	14718
4 - 6	F.V.520	14719
7 - 9	I.C.I.517	14717

Due to manufacturing difficulties experienced with the titanium alloy the webs of Specimens 7 - 9 were made with a 4T inside bend radius whereas those of Specimens 1 - 6 were made with an inside bend radius of 5T as specified.

The two outer sections used with all nine specimens were of slightly heavier construction in D.T.D.166 material and were joined to the centre section by means of butt straps on the skins and angles on the webs.

The main test portion (24" long) on the centre section was well away from the joints between the centre and outer sections.

A number of Chromel-Alumel thermocouples were electrically resistance-welded to the skins and outer webs of the specimens both inside and out so that adequate measurement of the temperature distribution over the test lengths could be made. The positions of these thermocouples are shown in Figures 3 - 5.

4. DESCRIPTION OF RIGS

4.1. Torsion Rig

The rig was manufactured to Drawing No. 14745 and is shown in Fig. 6 and in Plate No. 1. The specimen was clamped rigidly at one end and pivoted on the centre-line about its horizontal axis at the other where a pure couple was applied by means of a lever system loaded by a hydraulic jack and a spring balance.

$$\text{The applied torque} = \frac{\text{Total load}}{2} \times 30 = 15 P \text{ lb.in.}$$

P being the total applied load.

Dial gauges were attached in pairs to the top and bottom skin at several chordwise stations along the length of the specimen, as shown in Figs. 8 - 11, to determine the angular deflections. During the elevated temperature tests the gauges were mounted above the lamp trays as shown in Plate No. 4.

4.2. Bending Rig

The rig was manufactured to Drawing No. 14720 and is shown in Fig. 7 and Plate Nos. 2 and 3.

The specimens were supported at two points at 24" centres by links pivoted at the mid-depth of the specimen and the load was applied by means of a calibrated hydraulic jack and pressure gauge to two points at 156" centres through links similarly pivoted. Thus the mid-length of 24" was subjected to a constant bending moment and no shear.

$$\text{Bending moment} = \frac{\text{Total load}}{2} \times 66 = 33 P \text{ lb.in.}$$

where P = total applied load.

Dial gauges and four Vernier tapes were used in the positions shown in Figs. 12 - 14 to measure the deflections of the specimen.

During the elevated temperature tests the gauges were mounted above the lamp trays (Plate No. 4).

4.3. Heating System

Heat was supplied to the specimens from three lamp trays suspended above the top skin, and three below the bottom skin, each tray being backed by a reflector. The centre trays contained eight quartz infra-red lamps, and the outer trays each four similar lamps. The

output of each lamp was 1,000 watts at a nominal 250 volts, power being drawn from the 440-volt 3-phase mains and supplied to the lamps by way of a triple-gang 3-phase Variac transformer, allowing infinite manual control of the heat radiated, from zero to maximum.

The arrangement of the lamp trays is shown in Figs. 6 and 7.

The lamps in the centre tray were in two staggered rows pitched at 2.75" in each row and those in the outer tray at 5.5", transverse to the length of the specimen in all cases. The upper lamps were 4.25" above and the lower ones 4.25" below the specimen.

For the torsion test the trays were adjacent to each other but for the bending test they had to be separated to clear the rig (Plate No. 4). In both cases the lamps extended only over the centre section and the reduced number of lamps in the outer tray resulted in a graduation of temperature from the ends of the centre section to the test length.

5. METHOD OF TEST

The procedure adopted was the same for each set of specimens.

The torsional stiffness test at normal temperature was first carried out, followed by the bending test to failure on the same specimen. This programme was followed for the next specimen at 200°C and then the third at 500°C.

Prior to commencing the tests at elevated temperature a comprehensive series of preliminary heating tests was carried out on the first steel specimen after it had failed at normal temperature. The upper and lower surfaces were painted a matt black to assist heat absorption. These preliminary tests were made to determine the best arrangement of lamps to give as uniform a distribution of temperature as possible both in the skins and webs over the test length. It was found to be impossible to obtain a uniform temperature down the outer webs even with the side reflectors, and to reduce heating losses to a minimum the outside webs were left unblackened.

Because of the difference in conductivity between steel and titanium, similar preliminary check tests were also made on the first titanium specimen.

As no more uniform temperature distribution was obtained with the blackened surfaces subsequent specimens were left unpainted.

For the tests at elevated temperature the lamps were switched on and the heating continued until the required stabilised conditions were obtained. This took three to four hours.

A small load (torsion or bending as appropriate) was applied to settle the load system and then removed. Dial gauges were zeroed and loading commenced in increments, dial gauge readings being noted at each step. Temperature checks were also made at the termination of the stiffness tests.

For the stiffness tests the loadings were continued until the deflections were no longer linear.

6. RESULTS6.1. Torsion tests

A number of tests were carried out on each beam due to the difficulty in obtaining consistent readings, and only that which gave the most reasonable result has been included.

Each test took approximately $\frac{1}{2}$ -hour from the start of loading. The temperature distribution over the specimen was checked before and after each test and the observations together with the percentage variation are given in Table A. The dial gauge readings and the deflections are given in Tables B and C, and from these have been plotted the torsional deflections of the stations over the central test length, Figs. 15 - 23. These curves have been extrapolated linearly to a torque of 80,000 lb.in. and the equivalent deflections at this torque used to calculate the angular twist at the four stations. These twists have been plotted in Figs. 24 - 32 and used to determine the torsional stiffness of the specimens over a 20" length as shown in these figures and plotted in Fig. 33 against temperature.

The theoretical stiffnesses for the same torque and length of specimen have been calculated by Batho theory using the actual gauge thicknesses of the specimens. These have been taken as the mean of the thicknesses of the appropriate tensile and compressive control specimens as given in Table J. The actual width of the skins and depth of the Boxes as recorded in Table D have also been used. The theoretical and experimental stiffnesses are summarised in Table E. The value of 'E' in this table is the mean of the values determined for the control specimens from the top and bottom skins in tension and compression as given in Table J.

The predicted and effective moduli of rigidity used in determining the theoretical and experimental stiffnesses respectively are also given in Table E and are based on the formulae $G_p = \frac{E}{2(1+\mu)}$ and $G_E = \frac{T\theta_E}{J\theta_E}$ respectively, where μ = Poisson's Ratio, T = Torque, θ_E = length over which θ_E , the experimental angle of twist, was measured, and J = the torsional constant.

Measured moduli of rigidity, G_M , were obtained ultrasonically from specially made up specimens as described in paragraph 8. The effective moduli G_E obtained from these torsional tests are in reasonably close agreement with the measured values G_M .

6.2. Bending tests

The loading to destruction took approximately one hour in each case. The temperature distribution over the specimen was measured at the commencement of the test and is given in Table F.

The dial gauge deflection readings are given in Table G and the mean deflections at the various sections are plotted in Figs. 34 - 51.

Some of the support deflections are erratic, but the errors are negligible and may be due to sticking in the dial gauges. The deflections of the centres of the beams relative to the inner supports are plotted in Figs. 52 - 60, and the overall deflections of the beams at 10,000 lb. load (330,000 lb.in. Bending Moment) in Figs. 61 - 69.

The maximum loads at failure, the bending moments and the failing stresses based on the simple Engineer's theory are given in Table H.

Failure in each case was due to buckling of the compression skin and web flange and is shown in Plates 5 to 13.

The skins of the D.T.D.166 specimens (Nos. 1 - 3) buckled outwards and there was some tearing of the web in way of one web/skin attachment rivet. The F-V.520 specimens (Nos. 4 - 6) buckled inwards with no sign of any web tearing, whilst the titanium specimens (Nos. 7 - 9) buckled inwards and the web plates split along the heel of the flanges.

The effect of temperature on the ultimate bending stress is shown in Fig. 33.

7. CONTROL SPECIMENS

Standard tensile control specimens and compression specimens 2.65" x .625" with accurately squared ends were cut from the same sheets as the skins and webs of the Box Beams. The web specimens were used only for thickness measurements but the skin specimens were tested in the Avery test machine under the appropriate temperature conditions.

For the elevated temperature tests an oven was fitted to the machine and the specimens heated at approximately the same rates and for the same times to give the same temperatures as the test beams.

The stress-strain curves are given in Figs. 70 - 75 and the results summarised in Table J.

The variations of 'E' with temperature for the three materials are shown in Figs. 76 - 78.

8. MEASURED MODULUS OF RIGIDITY

As a result of the inconsistencies between the predicted and effective modulus of rigidity for titanium I.C.I.317 on test and shown in Table E, further small specimens (see sheet 21) were cut from each of the materials used for the skins and sent to the Basic Physics Division, N.P.L., Teddington, for determination of the modulus of rigidity in three planes by an ultra-sonic method. These results are given in Table K and show the material I.C.I.317 especially, to be anisotropic. These measured moduli were obtained at ambient temperatures only and the values for the plane LT are those given in Table E. The values quoted in this table for 200°C. and 300°C. have been obtained by decreasing the ambient value in the ratio of the appropriate E.

TABLE A

FORBION TESTS. TEMPERATURE DISTRIBUTION OVER BEAMS.

Thermo- couple No.	BEAM 2		BEAM 3		BEAM 5		BEAM 6		BEAM 8		BEAM 9	
	Before Test	After Test	Before Test	After Test	Before Test	After Test	Before Test	After Test	Before Test	After Test	Before Test	After Test
1	W157° C-	145	W230° C-	231° C-	W157° C-	154° C-	W221° C-	221° C-	W133° C-	134° C-	W231° C-	221° C-
2	W161-	145-	W-	-	W160-	160-	W230-	226-	W147-	148-	W227-	234-
3	193-	181-	274-	284-	186-	187-	269-	269-	192-	188-	265-	270-
4	197-	177-	285-	295-	191-	193-	267-	269-	192-	188-	297-	298-
5	207+	184-	276-	281-	193-	193-	252-	254-	193-	190-	299-	297-
6	200+	189-	284-	295-	202+	204+	304+	309+	190-	185-	286-	285-
7	188-	161-	261-	288-	198-	199-	267-	269-	202+	157-	287-	285-
8	188-	181-	296-	305+	188-	190-	264-	266-	202+	197-	307+	303+
9	195-	188-	277-	284-	198-	198-	280-	283-	202+	198-	280-	275-
10	200+	198-	282-	290-	203+	204+	303+	307+	194-	189-	-	-
11	W168-	W160-	W222-	228-	W159-	158-	W226-	226-	196-	192-	-	-
12	W180-	W171-	W242-	249-	W167-	167-	W225-	225-	199-	195-	290-	292-
13	194-	198-	273-	282-	207+	208+	291-	292-	W138-	134-	W243-	246-
14	-	-	291-	300+	222+	222+	316+	316+	W145-	141-	W193-	193-
15	201+	211+	279-	289-	212+	212+	314+	314+	187-	183-	285-	283-
16	192-	205+	282-	292-	216+	212+	314+	314+	199-	194-	305+	301+
17	182-	199-	278-	287-	215+	217+	296-	297-	192-	189-	-	-
18	175-	192-	273-	282-	206+	206+	300+	300+	199-	195-	290-	290-
19	182-	195-	280-	292-	310+	218+	310+	310+	192-	187-	297-	297-
20	175-	176-	280-	287-	305+	210+	309+	309+	197-	196-	295-	292-
21	-	-	280-	289-	315+	216+	316+	316+	202+	200+	304+	299-
22	-	-	277-	288-	312+	206+	315+	315+	192-	190-	275-	270-
23	-	-	-	-	-	-	-	-	195-	192-	295-	298-
24	-	-	-	-	-	-	-	-	193-	189-	293-	289-
% Vari- ation	16%	17%	13%	12.5%	18%	17.5%	12%	11%	7.5%	8.5%	10%	11%

See Figs. 3 - 5 for Thermocouple positions.

Prefix W. indicates Web temperatures.

TABLE B

DIAL GAUGE DEFLECTIONS - TORSTON TESTS

All Deflections given in ins.

Gauge Nos.	1	2	3	4	5	6	7	8	9	10	11	12	13	14	15	16	17	18	19	20	21	22
BEAM 1																						
0	0	0	0	0	0	0	0	0	0	0	0	0	0	0	0	0	0	0	0	0	0	0
15,000	.001	.005	.007	.016	.010	.011	.013	.014	.027	.014	.011	.009	.009	.008	.006	.005	.003	.001				
22,500	.003	.009	.019	.024	.021	.021	.027	.030	.045	.030	.022	.020	.020	.019	.012	.010	.007	.002				
30,000	.004	.015	.028	.031	.030	.032	.038	.043	.061	.044	.034	.030	.029	.026	.018	.015	.012	.003				
45,000	.009	.027	.043	.048	.052	.055	.066	.073	.095	.074	.060	.055	.050	.044	.031	.027	.021	.005				
52,500	.012	.033	.052	.058	.063	.068	.080	.088	.113	.089	.075	.064	.060	.053	.038	.033	.025	.007				
60,000	.015	.040	.061	.067	.074	.080	.094	.104	.131	.104	.086	.076	.071	.062	.045	.039	.030	.008				
75,000	.022	.054	.080	.086	.098	.107	.123	.136	.167	.135	.114	.100	.092	.081	.058	.051	.040	.010				
90,000	.025	.069	.099	.106	.124	.133	.152	.168	.204	.174	.140	.123	.114	.100	.72	.063	.050	.013				
BEAM 2																						
0	0	0	0	0	0	0	0	0	0	0	0	0	0	0	0	0	0	0	0	0	0	0
15,000	.001	.001	.003	.006	.010	.014	.017	.018	.018	.011	.009	.009	.008	.007	.006	.005	.004	.001				
22,800	.002	.005	.009	.013	.020	.026	.031	.033	.035	.025	.023	.019	.017	.015	.012	.010	.008	.002				
30,000	.003	.009	.011	.020	.029	.036	.046	.049	.061	.037	.035	.033	.028	.022	.019	.015	.012	.003				
37,500	.004	.013	.016	.028	.037	.047	.059	.062	.065	.052	.049	.044	.037	.031	.026	.022	.017	.003				
45,000	.006	.020	.022	.036	.049	.061	.074	.077	.080	.067	.062	.054	.046	.036	.033	.027	.022	.004				
52,500	.007	.025	.027	.043	.058	.072	.087	.092	.095	.082	.076	.067	.056	.046	.039	.034	.026	.0045				
60,000	.009	.030	.032	.054	.070	.085	.101	.106	.109	.097	.091	.079	.066	.055	.046	.040	.031	.006				
67,500	.011	.036	.040	.063	.082	.098	.117	.123	.126	.112	.103	.091	.076	.062	.053	.045	.035	.007				

TABLE B (Contd.)
DIAL GAUGE DEFLECTIONS - TORSION TESTS,
 All Deflections given in ins.

Gauge Nos.	1	2	3	4	5	6	7	8	9	10	11	12	13	14	15	16	17	18	19	20	21	22
BEAM 3																						
Torque Lb. In.																						
0	0	0	0	0	0	0	0	0	0	0	0	0	0	0	0	0	0	0	0	0	0	0
15,000	.001	.003	.006	.007	.007	.011	.009	.016	.017	.009	.007	.013	.003	0	.006	.004	0	0	0	0	0	0
22,500	.003	.007	.013	.014	.018	.022	.022	.029	.033	.025	.019	.025	.021	.017	.013	.010	.008	.001	.002	.002	.002	.002
30,000	.005	.013	.018	.020	.028	.033	.033	.044	.049	.040	.035	.038	.032	.027	.021	.019	.014	.004	.004	.004	.004	.004
37,500	.007	.020	.025	.030	.035	.044	.047	.060	.068	.056	.046	.051	.044	.036	.028	.025	.018	.005	.005	.005	.005	.005
45,000	.010	.025	.035	.038	.048	.060	.058	.077	.086	.072	.058	.064	.056	.046	.036	.031	.023	.006	.006	.006	.006	.006
52,500	.014	.034	.044	.047	.057	.072	.074	.094	.108	.086	.072	.076	.066	.054	.044	.038	.027	.007	.007	.007	.007	.007
60,000	.017	.042	.052	.059	.072	.085	.087	.112	.128	.102	.087	.087	.076	.061	.052	.042	.030	.008	.008	.008	.008	.008
BEAM 4																						
0	0	0	0	0	0	0	0	0	0	0	0	0	0	0	0	0	0	0	0	0	0	0
15,000	.003	.008	.010	.012	.013	.019	.020	.022	.026	.023	.021	.018	.016	.012	.010	.009	.007	.002	.002	.002	.002	.002
22,500	.005	.015	.017	.020	.023	.031	.033	.038	.043	.039	.035	.030	.027	.021	.016	.015	.011	.003	.003	.003	.003	.003
30,000	.008	.022	.025	.028	.033	.044	.047	.053	.060	.055	.049	.043	.038	.030	.023	.022	.016	.004	.004	.004	.004	.004
37,500	.011	.029	.034	.037	.044	.057	.061	.068	.078	.071	.065	.055	.049	.039	.031	.028	.020	.006	.006	.006	.006	.006
45,000	.015	.037	.042	.046	.055	.072	.075	.086	.096	.088	.076	.068	.060	.048	.038	.034	.025	.007	.007	.007	.007	.007
52,500	.019	.044	.051	.056	.066	.086	.090	.102	.114	.106	.091	.080	.071	.058	.045	.041	.030	.009	.009	.009	.009	.009
60,000	.024	.053	.060	.065	.078	.101	.104	.115	.127	.122	.107	.093	.083	.067	.053	.048	.035	.010	.010	.010	.010	.010
67,500	.033	.065	.073	.079	.093	.119	.123	.139	.155	.141	.123	.108	.096	.078	.060	.055	.040	.011	.011	.011	.011	.011
BEAM 5																						
0	0	0	0	0	0	0	0	0	0	0	0	0	0	0	0	0	0	0	0	0	0	0
15,000	.003	.007	.008	.009	.011	.014	.016	.018	.020	.019	.016	.013	.010	.007	.006	.007	.005	.002	.002	.002	.002	.002
22,950	.008	.015	.017	.019	.023	.029	.032	.035	.039	.035	.029	.022	.026	.020	.015	.015	.008	.003	.003	.003	.003	.003
30,150	.012	.022	.025	.028	.035	.043	.047	.053	.056	.051	.043	.034	.037	.027	.019	.018	.011	.004	.004	.004	.004	.004
37,500	.017	.030	.033	.037	.046	.055	.061	.068	.073	.069	.057	.045	.047	.038	.026	.026	.016	.005	.005	.005	.005	.005
45,000	.021	.038	.041	.048	.056	.070	.075	.085	.091	.085	.071	.059	.060	.048	.032	.032	.020	.006	.006	.006	.006	.006
52,500	.027	.047	.053	.058	.069	.086	.092	.103	.109	.103	.086	.072	.070	.056	.040	.041	.024	.008	.008	.008	.008	.008
60,000	.032	.056	.063	.068	.079	.100	.107	.119	.124	.120	.101	.085	.082	.065	.048	.047	.029	.009	.009	.009	.009	.009

TABLE B (Contd.)

DIAL GAUGE DEFLECTIONS - TORSION TESTS.

All Deflections given in ins.

Gauge No.	1	2	3	4	5	6	7	8	9	10	11	12	13	14	15	16	17	18	19	20	21	22	
TEAM 6																							
TORSION																							
lb. ins.																							
0	0	0	0	0	0	0	0	0	0	0	0	0	0	0	0	0	0	0	0	0	0	0	
15,300	.007	.011	.009	.013	.013	.013	.017	.020			.015	.014	.011	.009	.006	.005	.004						
22,950	.014	.020	.018	.023	.022	.023	.031	.035			.030	.026	.020	.018	.015	.012	.008						
30,000	.023	.030	.025	.038	.035	.038	.046	.054			.045	.037	.034	.022	.020	.019	.015						
37,500	.032	.041	.037	.047	.047	.053	.062	.073			.060	.051	.044	.035	.026	.025	.017						
45,000	.041	.051	.048	.060	.060	.067	.080	.092			.071	.061	.053	.045	.033	.031	.021						
52,500	.051	.062	.061	.075	.075	.082	.096	.112			.083	.071	.061	.051	.037	.036	.025						
60,000	.061	.073	.074	.090	.090	.099	.115	.132			.097	.081	.072	.059	.044	.041	.028						
0	0	0	0	0	0	0	0	0	0	0	0	0	0	0	0	0	0	0	0	0	0	0	0
15,000	.005	.005	.008	.009	.014	.018	.019	.024	.027	.029	.024	.021	.019	.014	.011	.0085	.007	.002					
22,500	.005	.009	.015	.0165	.024	.030	.033	.041	.045	.047	.039	.035	.030	.025	.017	.014	.012	.003					
30,000	.003	.014	.021	.0245	.036	.043	.049	.058	.065	.066	.056	.049	.043	.034	.025	.020	.017	.004					
37,500	.004	.019	.0285	.033	.047	.056	.064	.078	.084	.085	.071	.063	.055	.043	.032	.026	.021	.006					
45,000	.004	.0245	.036	.042	.059	.070	.080	.093	.104	.104	.088	.078	.068	.053	.039	.032	.025	.007					
52,500	.004	.030	.044	.051	.071	.084	.096	.117	.1245	.125	.106	.093	.082	.063	.047	.039	.030	.008					
60,000	.014	.036	.053	.060	.083	.098	.114	.131	.146	.145	.123	.110	.095	.074	.055	.045	.035	.010					
67,500	.013	.042	.061	.069	.095	.112	.130	.149	.165	.165	.140	.125	.109	.085	.062	.052	.040	.011					
0	0	0	0	0	0	0	0	0	0	0	0	0	0	0	0	0	0	0	0	0	0	0	0
15,000	.004	.004	.009	.012	.012	.019	.017	.018	.025	.019	.027	.024	.017	.018	.020	.015	.011	.013	.011	.005	.003	.001	.001
22,500	.001	.014	.021	.027	.028	.038	.037	.036	.046	.040	.053	.038	.025	.027	.027	.021	.018	.016	.012	.006	.003	.001	.001
30,000	.002	.022	.034	.045	.045	.056	.056	.058	.065	.063	.077	.050	.034	.035	.034	.032	.023	.018	.015	.007	.003	.001	.001
37,500	.001	.031	.048	.061	.063	.077	.079	.085	.090	.090	.105	.065	.044	.044	.043	.034	.028	.023	.017	.008	.003	.001	.001
45,000	.001	.040	.060	.078	.080	.097	.099	.104	.115	.116	.120	.077	.054	.054	.052	.041	.034	.033	.020	.007	.003	.001	.001
52,500	.001	.048	.071	.093	.096	.115	.116	.125	.137	.137	.153	.091	.064	.061	.060	.050	.040	.030	.024	.008	.003	.001	.001
57,250	.001	.051	.076	.098	.102	.124	.126	.133	.145	.147	.165	.096	.073	.074	.064	.052	.042	.032	.026	.008	.003	.001	.001

TABLE B (Contd.)

DIAL GAUGE DEFLECTIONS - TORSION TESTS.All deflections given in ins.

Gauge Nos.	1	2	3	4	5	6	7	8	9	10	11	12	13	14	15	16	17	18	19	20	21	22
<u>BEAM 2</u>																						
<u>Torque -</u>																						
<u>lb. ins.</u>																						
0	0	0	0	0	0	0	0	0	0	0	0	0	0	0	0	0	0	0	0	0	0	0
15,000	.001	.003	.010	.009	.014	.017	.020	.019	.020	.012	.011	.013	.07	.09	.007	.004	.001	.000				
22,500	.002	.008	.018	.021	.028	.033	.033	.034	.042	.030	.026	.028	.016	.020	.016	.010	.003	.001				
30,000	.003	.013	.027	.034	.041	.046	.048	.051	.064	.046	.037	.038	.029	.031	.022	.016	.006	.001				
37,500	.005	.020	.037	.048	.054	.063	.066	.069	.088	.064	.052	.049	.041	.040	.032	.023	.009	.002				
45,000	.007	.025	.048	.059	.073	.081	.085	.098	.110	.088	.072	.069	.053	.055	.049	.032	.015	.003				
52,500	.009	.029	.056	.069	.083	.096	.096	.110	.130	.110	.089	.087	.073	.070	.056	.040	.020	.004				

TABLE C

TORSION TESTS

All Deflections given in ins.

<u>BEAM 1</u>	<u>CHORDWISE RELATIVE DEFLECTIONS</u>			
	<u>GAUGES -</u>	<u>5/14</u>	<u>6/13</u>	<u>7/12</u>
<u>TORQUE - LB. INS.</u>				
0	0	0	0	0
15,000	.018	.020	.022	.025
22,500	.038	.040	.047	.052
30,000	.056	.061	.068	.077
45,000	.096	.105	.119	.133
52,500	.116	.128	.144	.161
60,000	.136	.151	.170	.190
75,000	.179	.199	.223	.250
90,000	.224	.247	.275	.308
<u>BEAM 2</u>				
<u>TORQUE - LB. INS.</u>				
0	0	0	0	0
15,000	.0175	.022	.026	.027
22,800	.035	.043	.050	.056
30,000	.051	.064	.079	.084
37,500	.068	.084	.103	.111
45,000	.085	.107	.128	.139
52,500	.104	.128	.154	.168
60,000	.125	.151	.180	.197
67,500	.144	.174	.208	.226
<u>BEAM 3</u>				
<u>TORQUE - LB. INS.</u>				
0	0	0	0	0
15,000	.015	.019	.022	.023
22,500	.035	.043	.047	.048
30,000	.055	.065	.071	.077
37,500	.071	.088	.098	.106
45,000	.094	.116	.122	.135
52,500	.111	.138	.150	.166
60,000	.133	.161	.174	.199
<u>BEAM 4</u>				
<u>TORQUE - LB. INS.</u>				
0	0	0	0	0
15,000	.025	.035	.038	.043
22,500	.044	.058	.063	.073
30,000	.063	.082	.090	.102
37,500	.083	.106	.116	.131
45,000	.103	.132	.143	.162
52,500	.124	.157	.170	.193
60,000	.145	.184	.197	.226
67,500	.171	.215	.231	.262

TABLE C (Contd.)

TORSION TESTS

All Deflections given in ins.

<u>BEAM 5</u>	<u>CHORDWISE RELATIVE DEFLECTIONS</u>				
<u>GAUGES</u>	<u>5/14</u>	<u>6/13</u>	<u>7/12</u>	<u>8/11</u>	
<u>Torque - lb.ins.</u>					
0	0	0	0	0	
15,000	.022	.029	.029	.034	
22,950	.043	.055	.054	.064	
30,150	.062	.080	.081	.096	
37,500	.084	.102	.106	.125	
45,000	.104	.130	.134	.156	
52,500	.125	.158	.164	.189	
60,000	.144	.182	.192	.220	
<u>BEAM 6</u>					
0	0	0	0	0	
15,300	.022	.024	.031	.035	
22,950	.040	.053	.057	.065	
30,000	.057	.072	.083	.099	
37,500	.082	.097	.113	.133	
45,000	.105	.120	.141	.163	
52,500	.126	.145	.167	.195	
60,000	.149	.171	.196	.229	
<u>BEAM 7</u>					
0	0	0	0	0	
15,000	.028	.037	.040	.048	
22,500	.047	.060	.068	.080	
30,000	.070	.086	.098	.114	
37,500	.090	.111	.127	.146	
45,000	.112	.138	.158	.182	
52,500	.134	.166	.189	.223	
60,000	.157	.193	.224	.254	
67,500	.180	.221	.255	.289	
<u>BEAM 8</u>					
<u>GAUGES:</u>	<u>5/18</u>	<u>6/17</u>	<u>7/16</u>	<u>8/15</u>	<u>9/14</u>
0	0	0	0	0	0
15,000	.025	.030	.032	.038	.043
22,500	.044	.056	.058	.063	.073
30,000	.063	.079	.088	.092	.100
37,500	.086	.105	.113	.128	.134
45,000	.113	.131	.140	.156	.169
52,500	.126	.155	.166	.185	.198
57,250	.134	.166	.178	.197	.219
<u>BEAM 9</u>					
<u>GAUGES:</u>	<u>4/15</u>	<u>5/14</u>	<u>6/13</u>	<u>7/12</u>	<u>8/11</u>
0	0	0	0	0	0
15,000	.016	.023	.024	.033	.030
22,500	.037	.048	.049	.061	.060
30,000	.056	.072	.075	.086	.088
37,500	.080	.094	.104	.115	.121
45,000	.108	.128	.134	.154	.170
52,500	.125	.153	.169	.183	.199

TABLE D
MULTI-WEB BOX BEAM DIMENSIONS

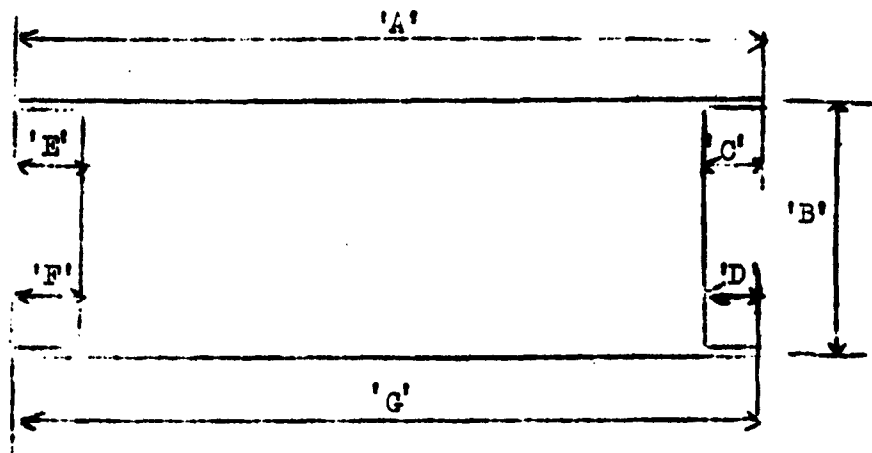

Dimensions in inches.

BEAM NO.	A	B	C	D	E	F	G
1	12.50"	4.10"	.69"	.69"	.72"	.71"	12.50"
2	12.52	4.07	.70	.70	.71	.71	12.52
3	12.50	4.14	.71	.71	.69	.69	12.50
4	12.53	4.10	.72	.73	.70	.70	12.53
5	12.50	4.09	.70	.70	.73	.73	12.50
6	12.56	4.14	.73	.72	.72	.72	12.56
7	12.72	4.10	.77	.76	.77	.77	12.5
8	12.70	4.12	.77	.75	.75	.75	12.5
9	12.74	4.12	.75	.75	.75	.75	12.6

TABLE E
THEORETICAL AND EXPERIMENTAL ANGLES OF TWIST MEASURED OVER 20"

Spec. No.	Material	Temp. °C.	Torsional Constant J - in. ⁴	E 10 ⁶ lb/in ²	Predicted Modulus of Rigidity G_p -10 ⁶ lb/in ²	Predicted Angle of Twist θ_p - Rad.	Measured Modulus of Rigidity G_M -10 ⁶ lb/in ²	Angle of Twist based on G_M -Rad.	Experimental Angle of Twist. θ_E - Rad.	Effective Modulus of Rigidity. G_E -10 ⁶ lb/in ²
1	D.V.D. 166	Amb.	22.6	24.7	9.5	.0075	10.55	.00685	.0072	9.8
2	"	200°	22.4	21.59	8.29	.0086	9.03	.00793	.0082	8.7
3	"	300°	23.4	20.46	7.88	.00874	8.59	.00796	.0090	7.6
4	F.V. 520	Amb.	22.0	26.5	10.18	.00718	10.59	.00685	.0066	11.09
5	"	200°	20.82	24.029	9.25	.0083	9.64	.00796	.0075	10.2
6	"	300°	22.2	22.06	8.48	.00868	8.83	.00825	.0082	8.82
7	I.C.I. 317	Amb.	27.2	15.97	6.14	.0093	5.57	.01058	.0115	5.12
8	"	200°	27.2	14.13	5.44	.0108	4.94	.01192	.0127	4.64
9	"	300°	27.6	12.95	4.98	.01154	4.53	.0128	.0143	4.05

TABLE F

BENDING TESTS

TEMPERATURE DISTRIBUTION OVER BEAMS

THERMO- COUPLE NOS.	BEAM 2	BEAM 3	BEAM 5	BEAM 6	BEAM 8	BEAM 9
1	W 149°C-	W 242°C-	W 157°C-	W 219°C-	W 143°C-	W 213°C-
2	W 149 -	W 234 -	W 158 -	W 226 -	W 162 -	W 226 -
3	190 -	299 -	206 +	255 -	194 -	256 -
4	192 -	282 -	209 +	275 -	197 -	289 -
5	180 -	282 -	178 -	256 -	177 -	282 -
6	194 -	296 -	194 -	288 -	179 -	266 -
7	191 -	287 -	208 +	273 -	200 +	277 -
8	199 -	289 -	201 +	278 -	195 -	295 -
9	-	282 -	-	277 -	187 -	291 -
10	200 +	290 -	194 -	288 -	183 -	273 -
11	W 150 -	W 243 -	W 159 -	W 226 -	192 -	311 +
12	W 159 -	W 236 -	W 161 -	W 223 -	195 -	296 -
13	188 -	294 -	194 -	-	W -	W 239 -
14	215 +	322 +	204 +	295 -	W -	W 221 -
15	210 +	300 +	207 +	294 -	180 -	271 -
16	209 +	314 +	201 +	306 +	196 -	293 -
17	-	312 +	188 -	284 -	184 -	270 -
18	199 -	304 +	214 +	277 -	200 +	294 -
19	201 +	297 -	215 +	294 -	200 +	289 -
20	194 -	302 +	217 +	291 -	179 -	284 -
21	204 +	294 -	211 +	301 +	202 +	316 +
22	202 +	-	209 +	290 -	191 -	291 -
23	-	-	-	-	195 -	317 +
24	-	-	-	-	197 -	309 +
% Variation:	17½%	13½%	19½%	17%	12½%	20½%

See Figs. 3 - 5 for Thermocouple positions.

Prefix 'W' indicates Web temperatures.

TABLE C

DIAL GAUGE DEFLECTIONS - BEADING

All Deflections Given in in.

GAUGE NOS.	T1	T2	1	2	3	4	5	6	7	8	9	10	11	12	13
BEAM 1															
Lead - 1b.															
0	0	0		0	0	0	0	0	0	0	0	0			0
1,200	.238	.238		.087	.045	.003	.001	.004	.001	.003	.042	.087			.088
2,400	.493	.494		.181	.094	.007	.003	.011	.004	.008	.091	.179			.191
3,600	.740	.745		.272	.141	.010	.007	.017	.006	.012	.137	.272			.273
4,000	1.035	1.042		.378	.194	.013	.010	.025	.009	.016	.192	.380			.380
6,200	1.302	1.313		.475	.244	.016	.014	.032	.012	.020	.243	.478			.478
7,600	-	1.632		.585	.299	.019	.018	.040	.016	.025	.302	.593			.593
8,800	1.982	2.005		.716	.368	.023	.024	.052	.021	.030	.371	.729			.727
10,100	2.263	2.318		.805	.423	.027	.029	.061	.025	.034	.430	.844			.838
11,400	2.585	2.645		.955	.955	.030	.035	.074	.030	.038	.500	.965			.966
BEAM 2															
0	0	0	0	0	0	0	0	0	0	0	0	0	0	0	0
440	.090	.200	.070	.004	.005	.004	.003	.002	.070	.079	.006	.008	.005	.008	.070
1,200	.300	.310	.106	.005	.006	.009	.008	.001	.110	.115	.006	.009	.014	.009	.104
2,400	.550	.595	.197	.005	.015	.016	.015	.00	.203	.209	.003	.018	.023	.009	.213
3,650	.885	.891	.306	.008	.025	.028	.026	.00	.292	.308	.003	.029	.033	.012	.310
4,950	1.230	1.220	.411	.015	.035	.042	.039	.010	.420	.422	.010	.042	.043	.016	.425
6,320	1.580	1.415	.519	.020	.050	.057	.052	.012	.518	.523	.017	.055	.060	.024	.529
7,560	1.930	1.900	.620	.024	.068	.076	.069	.018	.642	.654	.024	.072	.076	.030	.647
8,800	2.310	2.35	.741	.035	.092	.102	.093	.030	.763	.773	.038	.096	.100	.041	.770
10,020	2.740	2.700	.860	.046	.112	.127	.114	.042	.873	.873	.046	.119	.120	.052	.807
11,350	3.24	-	1.062	-	-	-	-	-	1.052	1.054	-	-	-	-	1.062
BEAM 3															
0	0	0	0	0	0	0	0	0	0	0	0	0	0	0	0
440	.210	.050	.060	.003	0	.0035	.001	.004	.049	.045	.003	5	6	.008	.075
1,200	.410	.240	.110	.001	.005	.005	.005	.007	.095	.083	.006	.011	.011	0	.126
2,400	.610	.550	.208	.004	.010	.016	.010	.013	.2064	.201	.009	.019	.016	.002	.217
3,650	.950	.790	.300	.005	.019	.024	.020	.013	.319	.299	.010	.025	.025	.001	.315
4,950	1.360	1.170	.417	.007	.027	.032	.024	.013	.441	.434	.007	.035	.033	.0005	.429
6,320	1.670	1.470	.525	.008	.035	.0405	.035	.010	.555	.547	.006	.040	.041	.0015	.548
7,560	2.020	1.780	.640	.003	.046	.0515	.042	.008	.687	.667	.008	.046	.052	.003	.667
8,200	2.250	2.030	.714	.004	.0525	.0585	.046	.008	.768	.750	.004	.049	.055	.002	.733
8,800	2.460	2.230	.780	.005	.056	.0625	.049	.010	.843	.810	.005	.052	.062	.001	.805
9,400	2.650	2.400	.839	.005	.0625	.0675	.055	.007	.911	.883	.004	.060	.065	.001	.875
10,020	2.860	2.630	.916	.0045	.071	.0765	.063	.004	1.000	.970	.003	.069	.077	.0015	.952
10,700	3.120	2.860	1.003	.003	.081	.0825	.079	.002	1.097	1.070	.001	.083	.087	.0034	1.088
11,360	3.390	3.120	1.100	-	-	-	-	-	1.189	1.150	.002	-	-	-	1.130
12,000	3.61	3.320	1.179	-	-	-	-	-	1.278	1.240	.004	-	-	-	1.215



TABLE G

BEAM DEFLECTIONS - HEMLOCK TEST.

All Deflections given in in.

Sheet No. 16

9	10	11	12	13	14	15	16	17	18	19	20	21	T ₁	T ₂
0	0			0	0	0	0	0	0	0	0	0	0	0
.042	.087			.088	.045	.002	.002	.005	.001	.003	.046	.089	.238	.238
.091	.179			.191	.093	.004	.005	.012	.004	.006	.095	.178	.493	.497
.137	.272			.273	.142	.0075	.010	.020	.007	.009	.142	.273	.742	.745
.192	.380			.380	.197	.008	.013	.028	.006	.012	.197	.381	1.037	1.038
.243	.478			.478	.248	.011	.018	.036	.014	.014	.247	.478	1.307	1.306
.302	.593			.593	.307	.015	.023	.045	.018	.017	.304	.590	1.620	1.608
.371	.729			.727	.377	.018	.030	.057	.023	.021	.372	.718	1.984	1.966
.430	.844			.838	.449	.020	.035	.074	.026	.024	.428	.830	2.300	2.250
.500	.965			.966	.512	.033	.044	.075	.028	.028	.504	.950	2.624	2.580
0	0	0	0	0									0	0
.006	.008	.005	.008	.070									.210	.170
.006	.009	.014	.009	.104									.300	.340
.003	.018	.023	.009	.213									.605	.600
.003	.029	.033	.012	.310									.892	.915
.010	.042	.043	.016	.425									1.230	1.230
.017	.055	.060	.024	.529									1.715	1.590
.024	.072	.076	.030	.647									1.910	1.940
.038	.096	.100	.041	.770									2.47	2.410
.046	.119	.120	.052	.907									2.730	2.740
-	-	-	-	1.062									-	3.24
0	0	0	0	0									0	0
.003	5	6	.008	.075									.140	.200
.006	.011	.011	0	.126									.250	.330
.009	.019	.016	.002	.217									.540	.620
.010	.025	.025	.001	.315									.810	.980
.007	.035	.033	.0005	.429									1.160	1.260
.006	.040	.041	.0015	.548									1.470	1.580
.008	.046	.052	.003	.667									1.810	1.900
.004	.049	.055	.002	.735									2.060	2.16
.005	.052	.062	.001	.805									2.240	2.350
.004	.060	.065	.001	.875									2.410	2.530
.003	.069	.077	.0015	.952									2.610	2.750
.001	.083	.087	.003	1.028									2.800	3.000
.002	-	-	-	1.130									3.160	3.300
.004	-	-	-	1.215									3.380	3.550



TABLE G (Contd)

DIAL GAUGE DEFLECTIONS - BEAMING

All Deflections given in in

GAUGE NOS.	T1	T2	1	2	3	4	5	6	7	8	9	10	11	12
BEAM 4														
Load - 1b ₄														
0	0	0	0	0	0	0	0	0	0	0	0	0	0	0
440	.140	.140	.040	.005	.003	.0025	.002	.001	.030	.032	.023	.004	.003	.025
1,200	.240	.260	.080	.004	.006	.009	.006	.002	.072	.074	.021	.00065	.007	.024
2,400	.490	.470	.164	.004	.010	.015	.012	.002	.156	.156	.021	.012	.014	.022
3,650	.730	.750	.248	.0035	.016	.023	.018	.001	.242	.244	.021	.018	.020	.022
4,950	1.000	1.010	.338	.003	.022	.030	.024	.000	.332	.334	.021	.0245	.027	.022
6,320	1.250	1.300	.426	.003	.030	.038	.030	.000	.423	.425	.021	.032	.034	.022
7,560	1.540	1.580	.524	.003	.036	.044	.037	.001	.510	.516	.020	.038	.039	.020
8,800	1.840	1.860	.612	.003	.042	.051	.043	0	.610	.614	.020	.045	.046	.020
10,020	2.120	2.140	.709	.003	.050	.059	.051	0	.710	.714	.020	.053	.051	.020
11,350	2.420	2.442	.810	.003	.059	.068	.060	.0005	.810	.816	.021	.062	.060	.020
BEAM 5														
0	0	0	0	0	0	0	0	0	0	0	0	0	0	0
440	.100	.175	.038	0	.003	.004	.002	0	.036	.04	0	.004	.003	0
1,200	.200	.23	.080	.011	.006	.008	.006	.001	.085	.086	.001	.008	.006	0
1,800	.325	.36	.132	.002	.009	.011	.010	0	.137	.139	0	.010	.010	0
2,400	.465	.51	.174	.003	.012	.014	.012	.001	.186	.186	.001	.014	.012	0
3,000	.580	.62	.222	.003	.015	.0175	.015	.001	.237	.239	.001	.0165	.016	0
3,700	.725	.76	.326	.0035	.018	.022	.018	.0015	.347	.348	.001	.020	.020	0
5,000	1.02	1.0	.422	.004	.025	.0315	.025	.001	.45	.453	.001	.027	.026	0
6,200	1.300	1.30	.532	.0045	.033	.0395	.035	.0005	.574	.575	0	.035	.035	0
7,600	1.58	1.66	.651	.0015	.042	.0495	.041	.001	.701	.705	.001	.045	.0425	0
8,800	1.950	2.0	.762	0	.052	.061	.053	.003	.820	.822	.004	.054	.053	.001
10,100	2.250	2.29	-	.0025	.063	.071	.062	.004	-	-	.006	.063	.063	.002
BEAM 6														
0	0	0	0	0	0	0	0	0	0	0	0	0	0	0
1,800	.334	.404	.112	.026	.035	.037	.034	.020	.098	.099	.020	.035	.039	.024
2,400	.524	.520	.150	.026	.042	.043	.040	.022	.140	.142	.022	.040	.043	.029
3,650	.820	.815	.244	.040	.062	.063	.057	.035	.234	.235	.036	.059	.064	.042
4,950	1.150	1.120	.344	.054	.084	.088	.080	.046	.335	.337	.048	.082	.085	.054
6,320	1.41	1.400	.422	.066	.100	.110	.102	.062	.416	.417	.063	.103	.112	.069
7,560	1.700	1.69	.508	.08	.128	.132	.123	.075	.500	.504	.077	.124	.129	.082
8,800	1.990	1.955	.590	.097	.150	.157	.146	.092	.593	.594	.093	.151	.160	.101
10,020	2.300	2.28	.680	.1010	.162	.170	.160	.097	.694	.695	.098	.161	.164	.102
11,350	2.66	2.60	.752	.120	-	.212	-	-	.853	.854	-	-	-	.1300



TABLE G (Contd.)

DIAL GAUGE DEFLECTIONS - BEARING TEST.

All Deflections given in in.

Sheet No. 17

	8	9	10	11	12	13	14	15	16	17	18	23	24
0	0	0	0	0	0	0						0	0
10	.032	.023	.004	.003	.025	.043						.140	.150
20	.074	.021	.0005	.007	.024	.084						.280	.250
30	.156	.021	.012	.014	.022	.166						.480	.490
40	.244	.021	.018	.020	.022	.251						.770	.740
50	.334	.021	.0245	.027	.022	.339						1.020	1.000
60	.425	.021	.032	.034	.022	.429						1.310	1.260
70	.516	.020	.038	.039	.020	.525						1.590	1.550
80	.614	.020	.045	.046	.020	.615						1.87	1.850
90	.710	.020	.053	.051	.020	.713						2.15	2.130
100	.816	.021	.062	.060	.020	.811						2.46	2.430
110	0	0	0	0	0	0						0	0
120	.04	0	.004	.003	0	.041						.225	.200
130	.086	.001	.008	.006	0	.084						.240	.400
140	.139	0	.010	.010	0	.133						.370	.525
150	.186	.001	.014	.012	0	.178						.520	.665
160	.239	.001	.0165	.016	0	.226						.630	.796
170	.348	.001	.020	.020	0	.328						.780	.925
180	.453	.001	.027	.026	0	.425						1.10	1.230
190	.575	0	.035	.035	0	.534						1.360	1.520
200	.705	.001	.045	.0425	0	.652						1.67	1.800
210	.822	.004	.054	.053	.001	.762						2.01	2.200
220	-	.006	.063	.063	.002	-						2.305	2.500
230	0	0	0	0	0	0						0	0
240	.099	.020	.035	.039	.024	.116						.406	.336
250	.142	.022	.040	.043	.029	.158						.530	.526
260	.235	.036	.059	.064	.042	.248						.815	.820
270	.337	.048	.082	.085	.054	.348						1.130	1.160
280	.417	.063	.103	.112	.069	.423						1.40	1.410
290	.504	.077	.124	.129	.082	.510						1.690	1.700
300	.594	.093	.151	.160	.101	.601						1.965	2.010
310	.695	.098	.161	.164	.102	.684						2.300	2.310
320	.854	-	-	-	.1300	.760						2.610	2.680



DIAL GAUGE DEFLECTIONS - BEAM
All Deflections given in

GAUGE NOS.	T1	T2	1	2	3	4	5	6	7	8	9	10	11	12
BEAM 7														
Lead - 1b.														
0	0	0	0	0	0	0	0	0	0	0	0	0	0	0
1,200	.340	.300	.140	.040	0	.010	.012	.015	.002	.032	.102	.106	.036	0
1,800	.470	.480	.180	.054	.001	.014	.016	.016	.012	.060	.170	.184	.070	.001
2,400	.600	.690	.230	.070	.001	.018	.018	.018	.018	.084	.230	.240	.088	.002
3,000	.800	.860	.296	.091	.001	.023	.024	.022	.0185	.100	.300	.302	.114	.002
3,600	.960	.990	.350	.110	.001	.026	.029	.029	.0185	.120	.352	.362	.134	.002
5,000	1.310	1.320	.475	.150	.0015	.036	.039	.037	.0185	.165	.480	.482	.169	.001
6,300	1.660	1.685	.596	.192	.003	.047	.050	.047	.017	.205	.600	.604	.209	0
7,000	1.820	1.830	.650	.200	.003	.052	.056	.052	.0165	.220	.663	.663	.230	.0005
7,600	2.000	2.000	.712	.210	.004	.058	.062	.058	.016	.241	.714	.718	.247	.0015
8,200	2.160	2.170	.770	.240	.004	.063	.068	.062	.0155	.261	.776	.776	.265	.002
8,800	2.370	2.320	.821	.265	.002	.066	.070	.064	.018	.280	.826	.830	.288	.002
9,400	2.530	2.540	.892	.290	.002	.074	.076	.070	.017	.300	.900	.904	.314	.0015
10,000	2.700	2.680	.950	.300	.002	.072	.079	.074	.017	.320	.950	.954	.328	.002
10,600	3.820	2.920	1.013	.330	.0011	.080	.086	.080	.017	.336	1.016	1.020	.340	.002
11,400	3.000	3.090	1.090	.354	.001	.085	.093	.086	.016	.365	1.060	1.064	.371	.003
12,000	3.200	3.225	1.160	.376	.001	.090	.096	.091	.015	.390	1.084	1.090	.390	.005
12,600	3.460	3.450	-	-	-	-	-	-	-	-	-	-	-	-
13,400	3.650	3.650	-	-	-	-	-	-	-	-	-	-	-	-
14,000	3.860	3.793	-	-	-	-	-	-	-	-	-	-	-	-
14,600	4.000	4.035	-	-	-	-	-	-	-	-	-	-	-	-
BEAM 8														
0	0	0	0	0	0	0	0	0	0	0	0	0	0	0
600	.22	.26	.075	.031	.002	.007	.008	.01	.02	.054	.108	.093	.058	.001
1,200	.40	.49	.1335	.054	.002	.009	.011	.01	.031	.096	.201	.173	.073	.004
1,800	.62	.76	.207	.083	.002	.013	.013	.015	.037	.138	.298	.265	.107	.006
2,400	.79	.940	.266	.105	.002	.020	.017	.019	.038	.165	.357	.330	.131	.008
3,600	1.13	1.310	.386	.152	.003	.026	.027	.029	.04	.215	.489	.450	.178	.007
5,000	1.50	1.660	.507	.198	.002	.037	.038	.039	.041	.261	.612	.571	.221	.007
6,300	1.90	2.06	.630	.249	0	.048	.053	.052	.041	.312	.731	.697	.269	.003
7,600	2.30	2.49	.777	.306	.002	.06	.065	.060	.042	.371	.880	.841	.323	.003
8,800	2.700	2.88	.908	.351	.002	.074	.081	.078	.036	.417	1.015	.974	.365	.001
10,000	3.13	3.30	1.050	.399	.011	.09	.105	.098	.026	.466	1.160	1.115	.409	.010
11,400	3.6	3.79	1.207	.445	.025	.126	.135	.130	.012	.515	1.310	1.261	.450	.014
12,600	4.0	3.85	-	-	-	-	-	-	-	-	-	-	-	-
BEAM 9														
0	0	0	0	0	0	0	0	0	0	0	0	0	0	0
600	.120	.110	.051	.019	.002	.019	.01	.011	.009	.024	.052	.056	.021	.008
1,210	.450	.350	.164	.067	.003	.021	.01	.012	.013	.060	.140	.145	.067	.0085
1,800	.610	.560	.271	.114	.004	.022	.012	.014	.013	.088	.212	.222	.086	.0065
3,080	1.15	.980	.419	.174	.004	.032	.128	.026	.012	.140	.350	.360	.139	.003
4,360	1.50	1.340	.541	.226	.002	.044	.04	.04	.007	.187	.472	.486	.186	.0025
5,680	1.900	1.740	.680	.282	.001	.054	.05	.05	.010	.240	.609	.624	.238	.0035
7,000	2.440	2.190	.836	.339	0	.066	.063	.063	.009	.295	.762	.780	.298	.005
8,280	2.750	2.570	.971	.392	.003	.077	.075	.08	.007	.340	.892	.912	.332	.005
9,480	3.200	3.010	1.124	.444	.006	.093	.092	.091	.002	.381	1.035	1.060	.381	.007
10,680	3.650	3.360	-	-	-	-	-	-	-	-	-	-	-	-



TABLE G (Contd.)

DIAL GAUGE DEFLECTIONS - BENDING TEST.
All Deflections given in ins.

Sheet No. 18

8	9	10	11	12	13	14	15	16	17	18	T ₃	T ₄
0	0	0	0	0	0	0	0	0	0	0	0	0
.032	.102	.106	.036	0	.017	.016	.014	0	.048	.142	.310	.380
.060	.170	.184	.070	.001	.018	.018	.016	.001	.062	.196	.490	.510
.084	.230	.240	.088	.002	.020	.020	.018	.0015	.074	.234	.650	.640
.100	.300	.302	.114	.002	.026	.026	.025	.002	.095	.300	.870	.800
.120	.352	.362	.134	.002	.031	.033	.030	.002	.114	.362	1.000	.980
.145	.480	.482	.169	.001	.041	.043	.040	.004	.154	.479	1.350	1.330
.165	.600	.604	.209	0	.057	.054	.051	.005	.192	.600	1.685	1.660
.180	.663	.663	.230	.0005	.056	.060	.056	.0055	.220	.658	1.860	1.840
.191	.714	.718	.247	.0015	.060	.064	.060	.006	.250	.714	2.010	2.000
.201	.776	.776	.265	.002	.066	.070	.065	.007	.258	.774	2.200	2.180
.210	.826	.830	.288	.002	.068	.072	.070	.005	.273	.827	2.330	2.390
.220	.880	.904	.314	.0015	.074	.078	.078	.006	.296	.900	2.550	2.550
.230	.950	.954	.328	.002	.078	.083	.078	.006	.318	.952	2.710	2.700
.245	1.016	1.020	.340	.002	.082	.090	.082	.006	.334	1.017	2.950	2.860
.255	1.060	1.064	.371	.003	.090	.097	.089	.007	.358	1.094	3.100	3.180
.260	1.084	1.090	.390	.005	.095	.100	.094	.007	.380	1.168	3.225	3.400
-	-	-	-	-	-	-	-	-	-	-	3.480	3.480
-	-	-	-	-	-	-	-	-	-	-	3.660	3.670
-	-	-	-	-	-	-	-	-	-	-	3.797	3.800
-	-	-	-	-	-	-	-	-	-	-	4.035	4.120
0	0	0	0	0	0	0	0	0	0	0	0	0
.108	.093	.058	.001	.014	.007	.008	0	.021	.067	.260	.220	
.201	.173	.073	.004	.014	.012	.010	0	.048	.125	.490	.400	
.298	.265	.107	.006	.017	.014	.014	0	.072	.197	.730	.600	
.357	.330	.131	.008	.021	.018	.021	0	.091	.257	.920	.760	
.489	.450	.178	.007	.031	.028	.029	0	.136	.377	1.280	1.120	
.612	.571	.221	.007	.041	.039	.038	.0015	.181	.500	1.650	1.500	
.731	.697	.269	.003	.054	.056	.051	.003	.231	.615	2.040	1.890	
.880	.841	.323	.003	.066	.066	.061	.003	.288	.761	2.46	2.310	
1.015	.974	.365	.001	.082	.082	.075	.004	.333	.894	2.860	2.690	
1.160	1.115	.409	.010	.102	.102	.091	.015	.379	1.033	3.280	3.120	
1.310	1.261	.450	.024	.136	.136	.127	.029	.428	1.777	3.730	3.560	
-	-	-	-	-	-	-	-	-	-	4.170	3.980	
0	0	0	0	0	0	0	0	0	0	0	0	0
.052	.056	.021	.008	.014	.015	.010	-	.028	.061	.160	.160	
.140	.145	.067	.0085	.017	.016	.012	-	.085	.184	.400	.460	
.212	.222	.086	.0065	.021	.018	.014	-	.141	.301	.620	.760	
.350	.360	.139	.003	.034	.032	.024	-	.201	.453	1.020	1.180	
.472	.486	.186	.0025	.045	.043	.035	-	.249	.588	1.400	1.570	
.609	.624	.238	.0035	.055	.053	.046	-	.300	.729	1.800	1.960	
.762	.780	.298	.0005	.070	.070	.062	-	.355	.889	2.240	2.430	
.891	.912	.332	.003	.083	.084	.071	-	.401	1.023	2.62	2.810	
1.036	1.060	.381	.007	.098	.097	.088	-	.451	1.167	3.07	3.260	
-	-	-	-	-	-	-	-	-	-	3.25	3.750	



TABLE H

Spec. No.	Temp. °C.	Failing Load. lb.	Bending Moment at failure. lb.ins.	Calculated Failing Stress. lb/in. ²
1	Ambient	13,000	430,000	68,500
2	200°	12,150	400,000	63,600
3	300°	12,300	406,000	64,700
4	Ambient	12,760	420,000	68,800
5	200°	10,900	360,000	59,000
6	300°	11,000	363,000	59,500
7	Ambient	15,400	508,000	67,500
8	200°	13,500	436,000	58,000
9	300°	11,200	370,000	49,200

TABLE J
CONTROL SPECIMENS

SPECIFICATION BEAM NO. TEST TEMPERATURE °C POSITION IN BEAM SPEC. NO. THICKNESS - INS. C.S. AREA in. ² .1% PROOF STRESS lb/in. ² 'E' 10 ⁶ lb/in. ²	D.T.D. 166						FIRTH VICKERS			
	1 Ambient		2 200		3 300		4 Ambient		5 200	
	BOTTOM SKIN - TENSILE						BOTTOM SKIN - TENSILE			
	B1A	B1B	B2A	B2B	B3A	B3B	B4A	B4B	B5A	B5B
	.114	.111	.108	.111	.113	.114	.108	.111	.1075	.107
	.0568	.0532	.0542	.0553	.0564	.0572	.0537	.0548	.0538	.053
	101,700	97,500	78,000	77,200	74,000	-	107,500	110,000	96,500	96,500
	25.4	23.1	23.4	20.8	20.8	-	26.7	26.7	24.6	24.6
POSITION IN BEAM SPEC. NO. THICKNESS - INS. C.S. AREA in. ² .1% PROOF STRESS lb/in. ² 'E' 10 ⁶ lb/in. ²	TOP SKIN - TENSILE						TOP SKIN - TENSILE			
	T1A	T1B	T2A	T2B	T3A	T3B	T4A	T4B	T5A	T5B
	.108	.111	.112	.113	.1125	.114	.108	.108	.109	.109
	.0533	.055	.0561	.0566	.0553	.0572	.0515	.0535	.0537	.0537
	88,500	97,200	78,000	72,000	76,000	75,000	110,000	113,000	100,100	100,100
	24.9	23.5	20.2	21.85	19.8	20.0	26.05	26.05	24.15	24.15
POSITION IN BEAM SPEC. NO. THICKNESS - INS.	WEB - TENSILE						WEB - TENSILE			
	OW1	IW1	OW2	IW2	OW3	IW3	OW4	IW4	OW5	IW5
	.052	.0525	.051	.05	.051	.051	.049	.051	.051	.051
POSITION IN BEAM SPEC. NO. THICKNESS - INS. C.S. AREA in. ² .1% PROOF STRESS lb/in. ² 'E' 10 ⁶ lb/in. ²	BOTTOM SKIN - COMPRESSION						BOTTOM SKIN - COMPRESSION			
	B1C	B1D	B2C	B2D	B3C	B3D	B4C	B4D	B5C	B5D
	.113	.1135	.114	.109	.1135	.1135	.108	.109	.107	.107
	.0708	.0713	.0716	.0685	.0713	.0713	.0678	.0685	.0673	.0673
	88,500	92,000	-	65,200	66,000	76,000	108,000	104,000	-	-
	24.9	24.57	-	21.7	21.1	19.9	27.1	25.1	-	-
POSITION IN BEAM SPEC. NO. THICKNESS - INS. C.S. AREA in. ² .1% PROOF STRESS lb/in. ² 'E' 10 ⁶ lb/in. ²	TOP SKIN - COMPRESSION						TOP SKIN - COMPRESSION			
	T1C	T1D	T2C	T2D	T3C	T3D	T4C	T4D	T5C	T5D
	.109	.110	.113	.113	.112	.112	.106	.106	.107	.107
	.0684	.0692	.071	.0708	.0702	.0701	.0666	.0666	.0672	.0672
	88,500	90,500	69,500	70,500	72,800	72,500	117,000	115,000	101,000	101,000
	25.6	25.6	21.5	21.7	20.8	20.8	26.2	27.4	22.2	22.2
POSITION IN BEAM SPEC. NO. THICKNESS - INS.	WEB - COMPRESSION						WEB - COMPRESSION			
	W1C	W1D	W2C	W2D	W3C	W3D	W4C	W4D	W5C	W5D
	.051	.051	.052	.052	.052	.054	.053	.047	.049	.049



TABLE J

CONTROL SPECIMENS

FIRTH VICKERS 520					TITANIUM ALLOY I.C.I. 317						
4 Ambient		5 200			6 300	7 Ambient		8 200		9 300	
BOTTOM SKIN - TENSILE					BOTTOM SKIN - TENSILE						
B4B	B5A	B5B	B6A	B6B	B7A	B7B	B8A	B8B	B9A	B9B	
.111	.1075	.107	.111	.111	.125	.123	.128	.126	.127	-	
.0548	.0538	.0534	.0556	.0557	.0618	.062	.064	.063	.0637	.0633	
110,000	96,500	98,000	93,500	93,500	105,000	106,000	65,500	66,000	54,000	54,000	
26.7	24.6	25.4	23.8	23.2	15.1	15.7	13.7	13.7	12.5	12.85	
TOP SKIN - TENSILE					TOP SKIN - TENSILE						
T4B	T5A	T5B	T6A	T6B	T7A	T7B	T8A	T8B	T9A	T9B	
.108	.109	.107	.107	.107	.129	.130	.129	.130	.131	.131	
.0535	.0537	.0535	.0545	.0536	.0593	.0645	.0642	.065	.0644	.0655	
113,000	100,100	99,000	92,500	89,500	117,000	116,000	72,000	70,000	56,000	55,500	
26.05	24.15	24.4	23.25	23.25	15.4	15.95	14.3	13.75	12.88	12.55	
WEB - TENSILE					WEB - TENSILE						
IW4	OW5	IW5	OW6	IW6	OW7	IW7	OW8	IW8	OW9	IW9	
.051	.051	.0475	.049	.05	.066	.064	.063	.065	.064	.067	
BOTTOM SKIN - COMPRESSION					BOTTOM SKIN - COMPRESSION						
B4D	B5C	B5D	B6C	B6D	B7C	B7D	B8C	B8D	B9C	B9D	
.109	.107	.107	.111	.111	.124	.123	.127	.128	.129	.128	
.0685	.0673	.0673	.0697	.0697	.0775	.0766	.0794	.0808	.081	.0805	
104,000	-	98,000	91,000	-	-	109,000	66,000	-	51,000	-	
25.1	-	23.75	19.0	19.4	16.15	16.7	14.4	14.6	12.82	13.3	
TOP SKIN - COMPRESSION					TOP SKIN - COMPRESSION						
T4D	T5C	T5D	T6C	T6D	T7C	T7D	T8C	T8D	T9C	T9D	
.106	.107	.107	.105	.108	.128	.128	.130	.130	.131	.132	
.0666	.0672	.0672	.066	.0678	.08	.0805	.082	.0817	.0818	.0826	
115,000	101,000	94,000	93,500	86,000	116,000	118,000	75,000	72,500	58,000	55,500	
27.4	22.2	23.7	22.3	22.3	16.5	16.4	14.2	14.6	13.45	13.1	
WEB - COMPRESSION					WEB - COMPRESSION						
W4D	W5C	W5D	W6C	W6D	W7C	W7D	W8C	W8D	W9C	W9D	
.047	.049	.048	.05	.05	.065	.065	.065	.065	.065	.065	

2

TABLE K

Measured Modulus of Rigidity from Ultra-sonic method. G_u .

Material Plane in which Modulus is measured	D.T.D.166	F.V.520	I.C.I.317
	$G_u \times 10^6 \text{ lb/in.}^2$		
LT	10.77	11.41	7.37
LB	10.35	10.59	5.57
BT	9.76	10.93	7.45

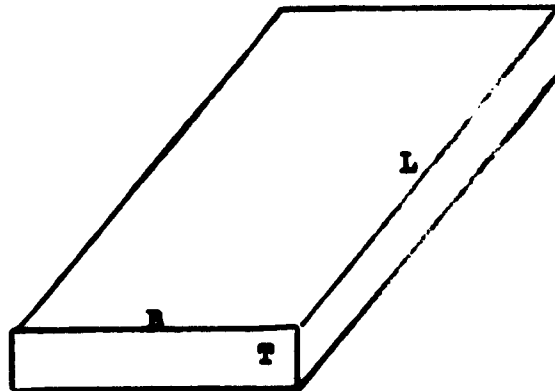

SECTIONS FOR ULTRA-SONIC
DETERMINATION OF G_u .

- L = 0.5"
- B = 0.375"
- T = SKIN THICKNESS OF MATERIAL

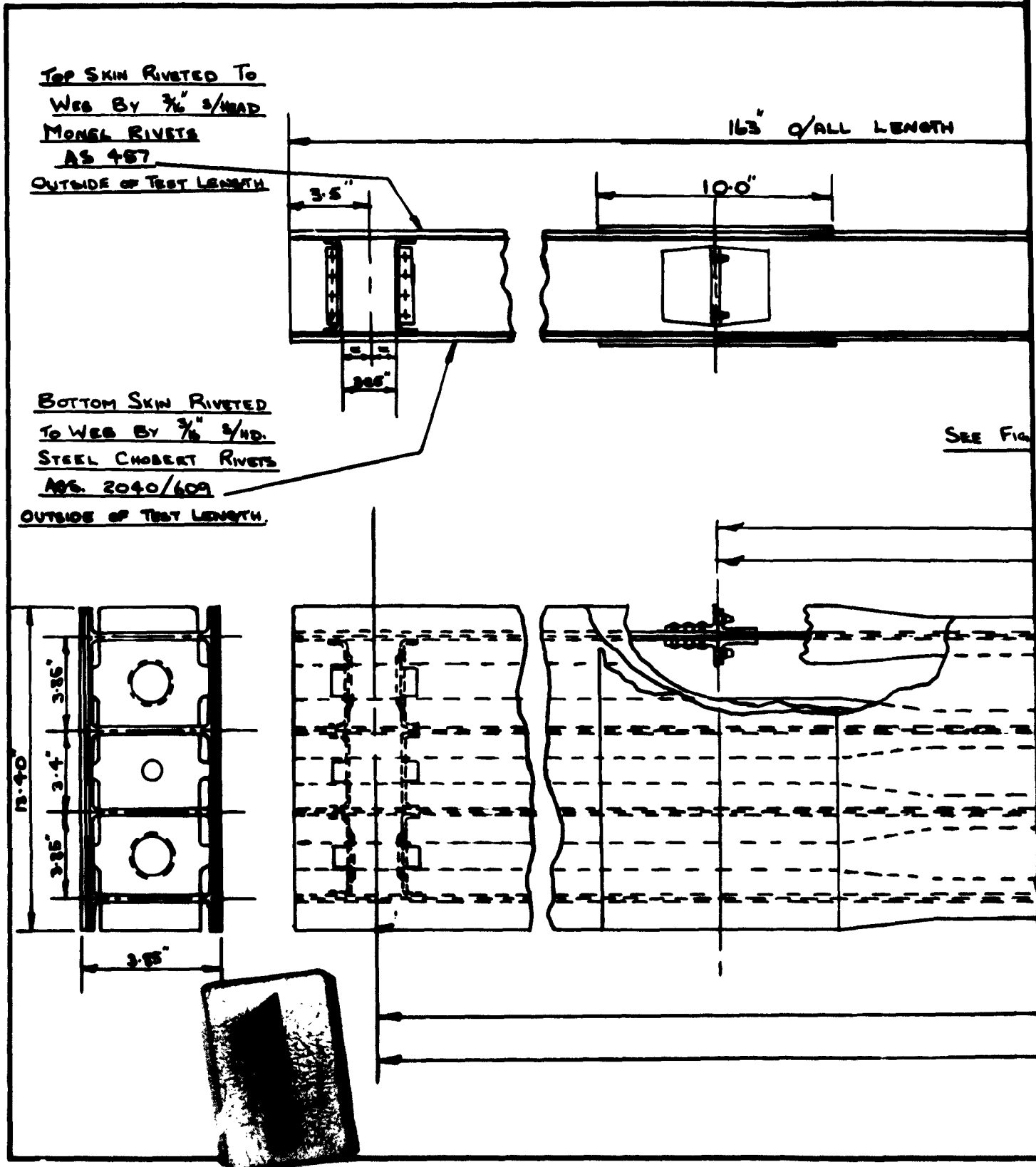

TITANIUM AND STEEL MULTIWEB BOX BEAM

163" O'ALL LENGTH

20"

TEST LENGTH 24" CRS.

STRAINING POINT

SEE FIG. 2 FOR DETAILS OF TEST LENGTH.

SPECIMEN

71.0" CRS.

156.0" CRS.

DRG. No. 14716-9

BOX BEAM SPECIMEN

FIG. 1



NOTE: FOR SPECIMENS 7-9, BOLTS WERE CUT 0.2" UNDERSTILE AND THESE WERE PLACED ON THE TENSION SIDE. SPECIMENS 7-9 HAD A 4T INSIDE BEND RADIUS OF THE WEB, WHEREAS SPECIMENS 1-6 HAD A 3T BEND RADIUS.

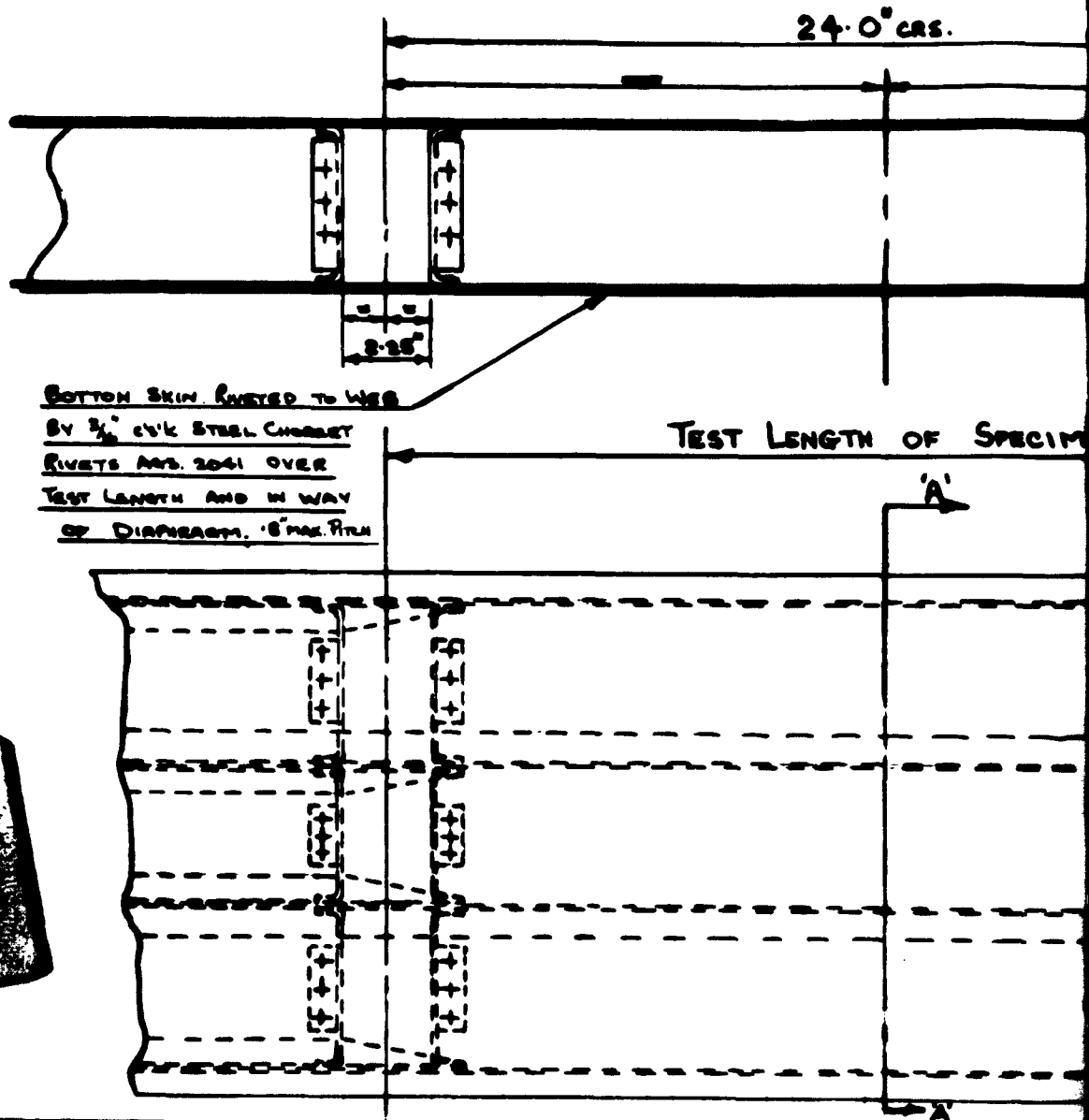

	SKIN	WEB	DIAPHRAGM	FLANGE WIDTH
SPECS. 1,2,3 B.T.D. 146	12.000	18.000	18.000	7.000
SPECS. 4,5,6 Form Vickers 620	12.000	18.000	14.000	7.000
SPECS. 7,8,9 Titanium Alloy 101 217	10.000	16.000	16.000	8.000

TITANIUM AND STEEL MULTIWEB BOX BEAM S

TOP SKIN RIVETED TO WEB
 BY $\frac{3}{16}$ " C&K MONEL RIVETS AS462
 OVER TEST LENGTH & IN WAY OF DIAPHRAGMS.
 5" MAX. PITCH.

24" O' CRS.

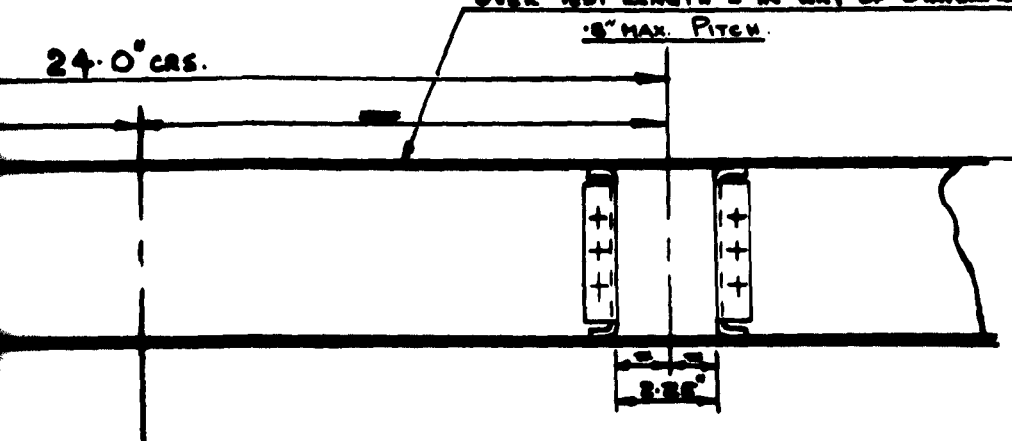

LENGTH OF SPECIMEN

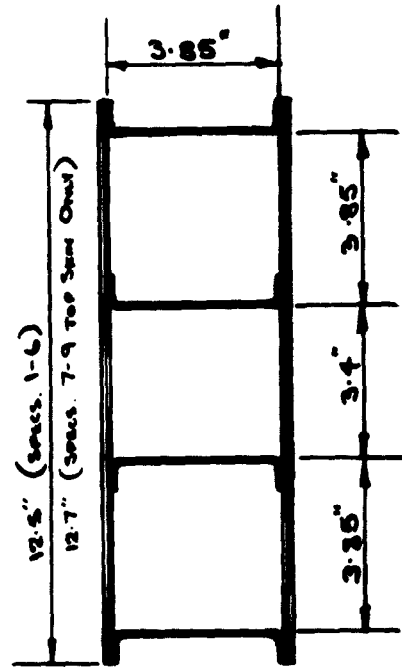
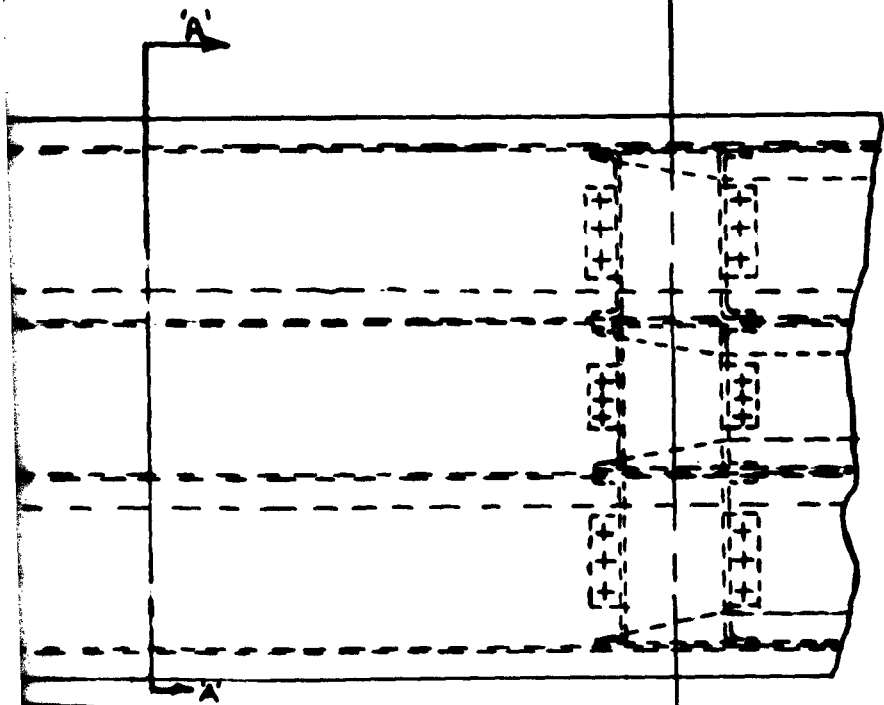

SECTION 'A-A'

DRG. No. 14716-9

BEAM SPECIMEN

FIG.
2

2

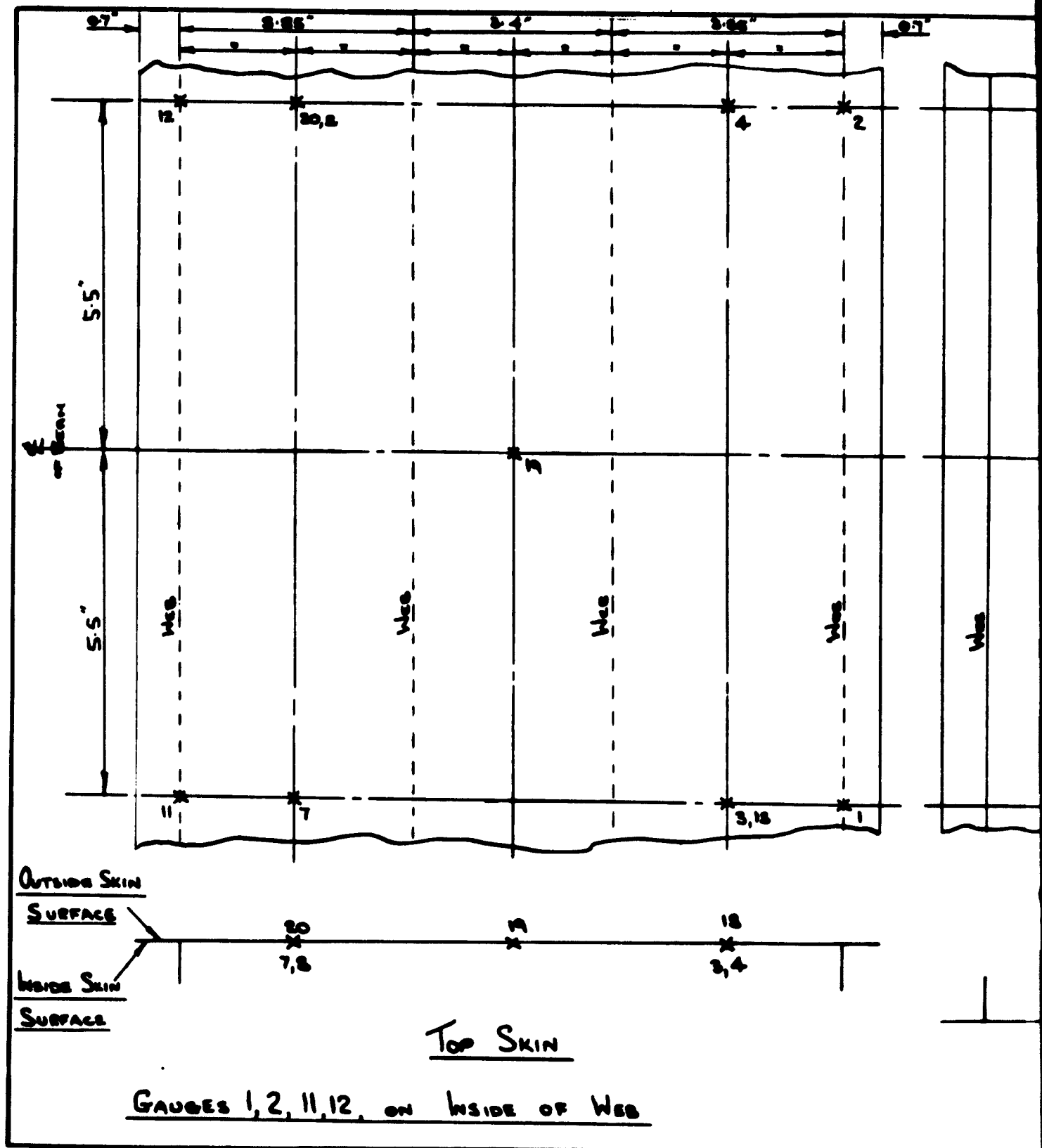

THERMOCOUPLE POSITIONS FOR MULTIPLE WEB BEAM 67

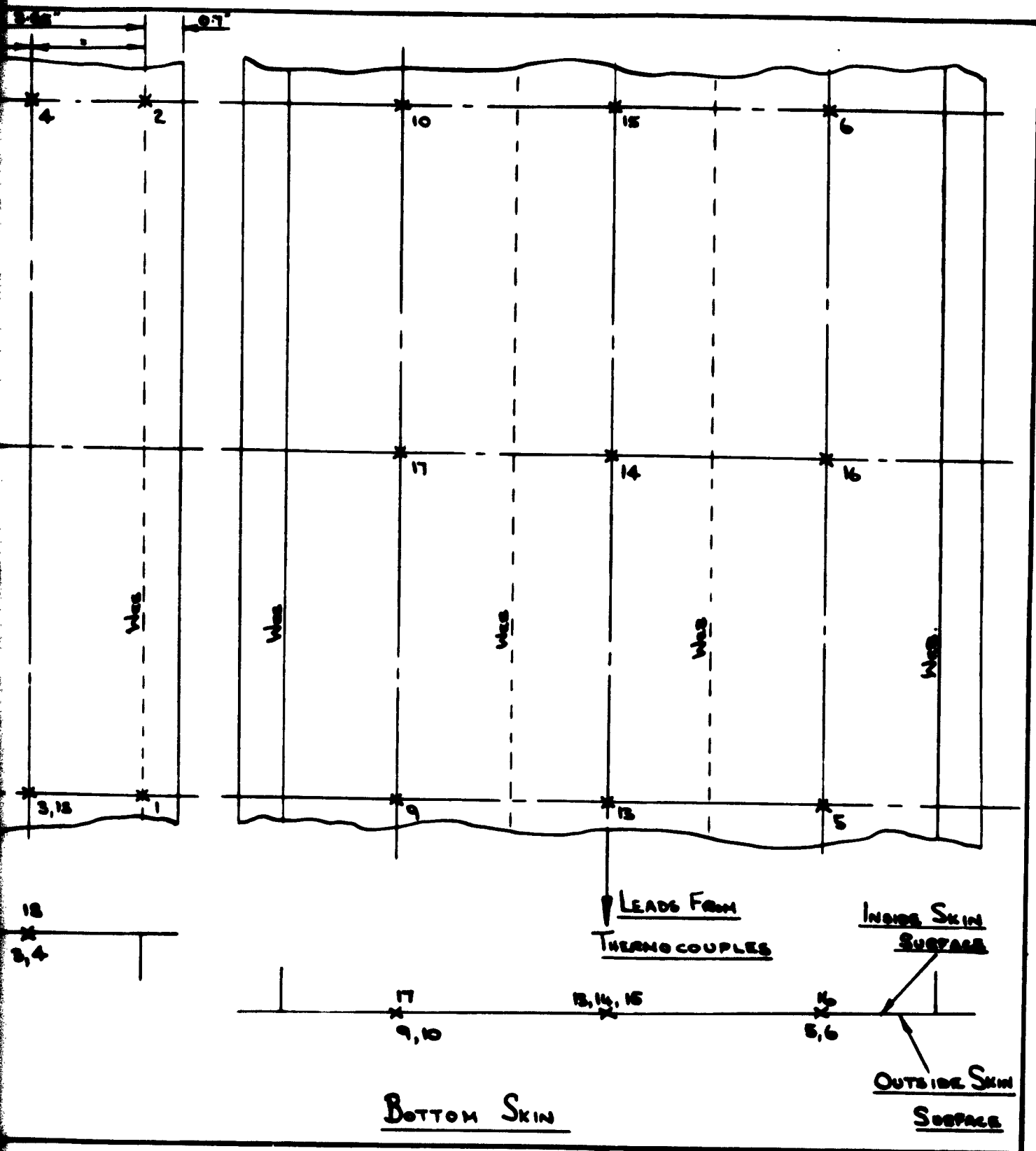

Box Beams (D.T.D. 166) SPEC. 2.

SEE TABLES A AND F FOR BEAM TEMPERATURES.

FIG. 3



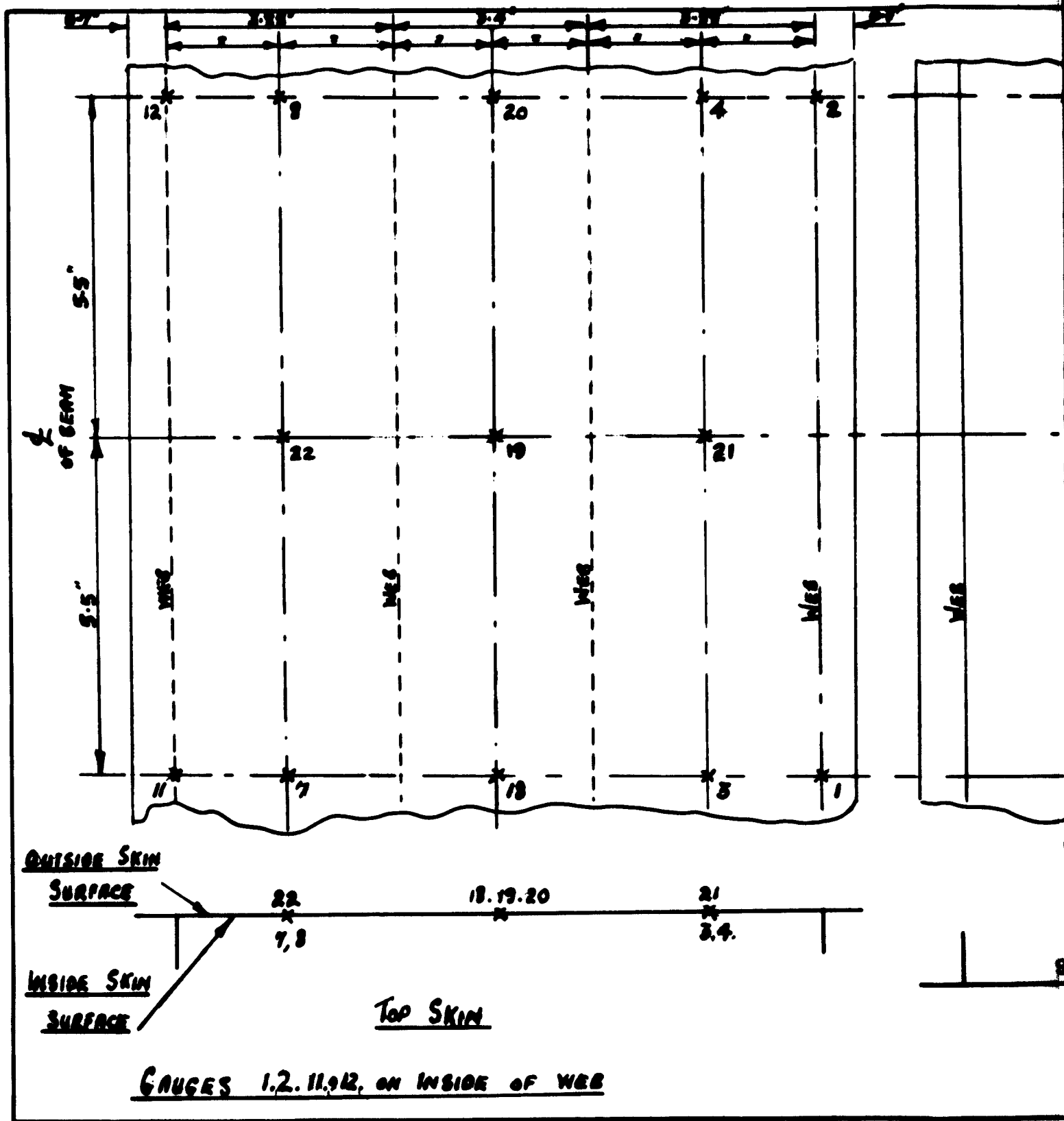

THERMOCOUPLE POSITIONS FOR MULTINEB BOX BEAMS (D.T.O. 166)

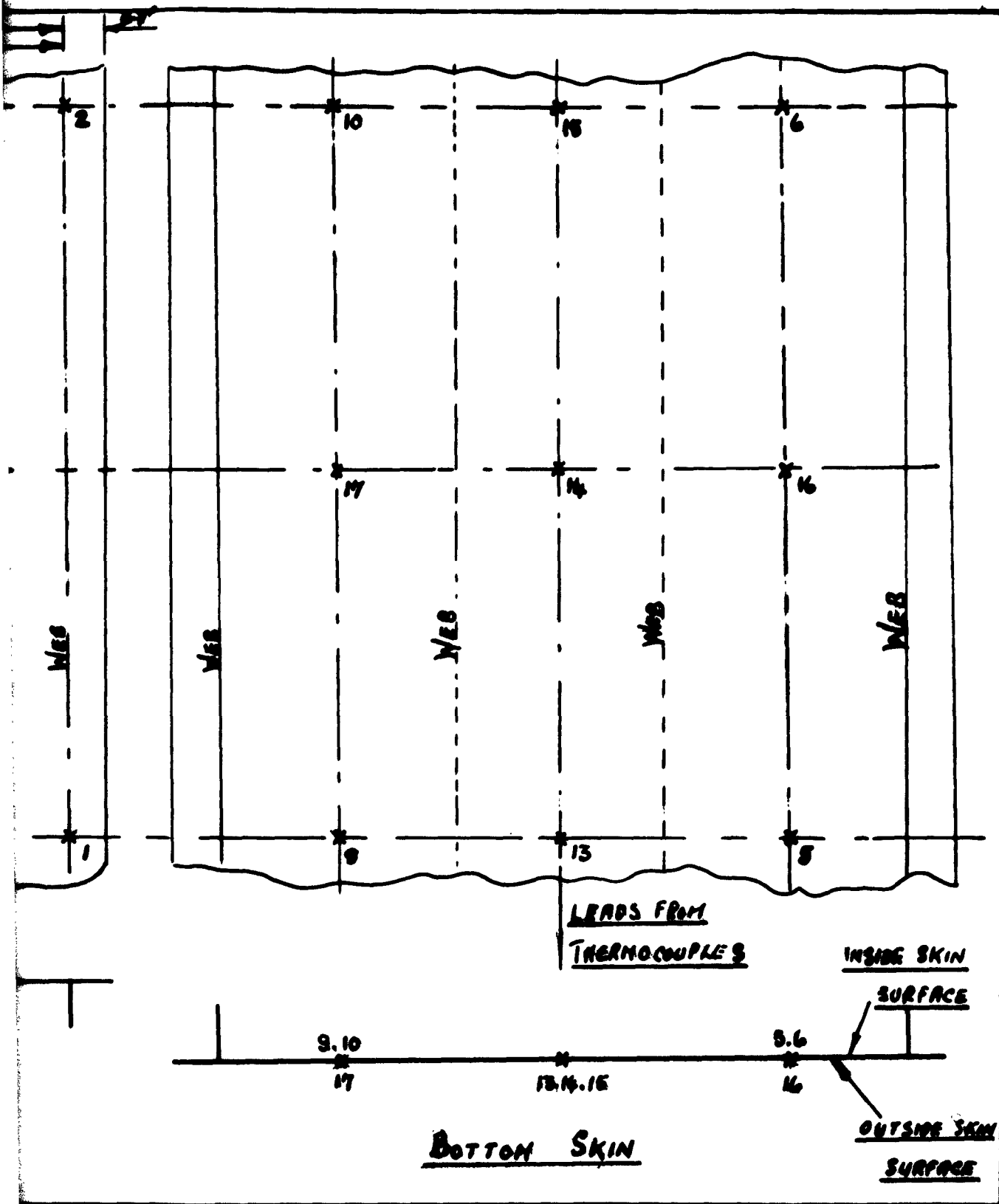

BOX BEAMS (D.T.O.166) SPEC 3 (FY 520) SPEC 5+6 SEE TABLES A + F FIG. FOR BEAM TEMPERATURES ↑

2

SAUNDERS-ROE LTD.

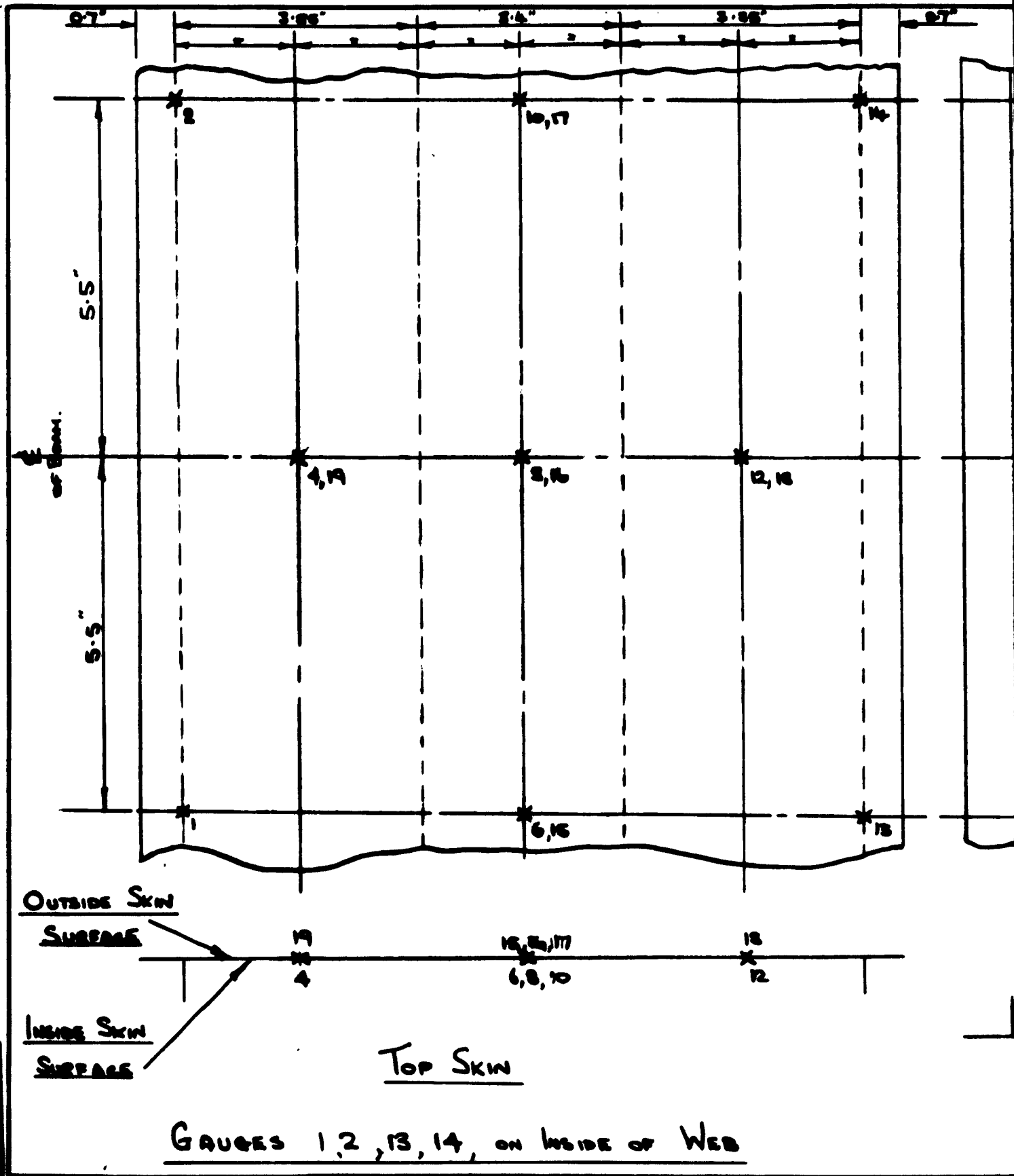

THERMOCOUPLE POSITIONS FOR MULTILED BOX BEAMS (I.C.I. 297) SPEC

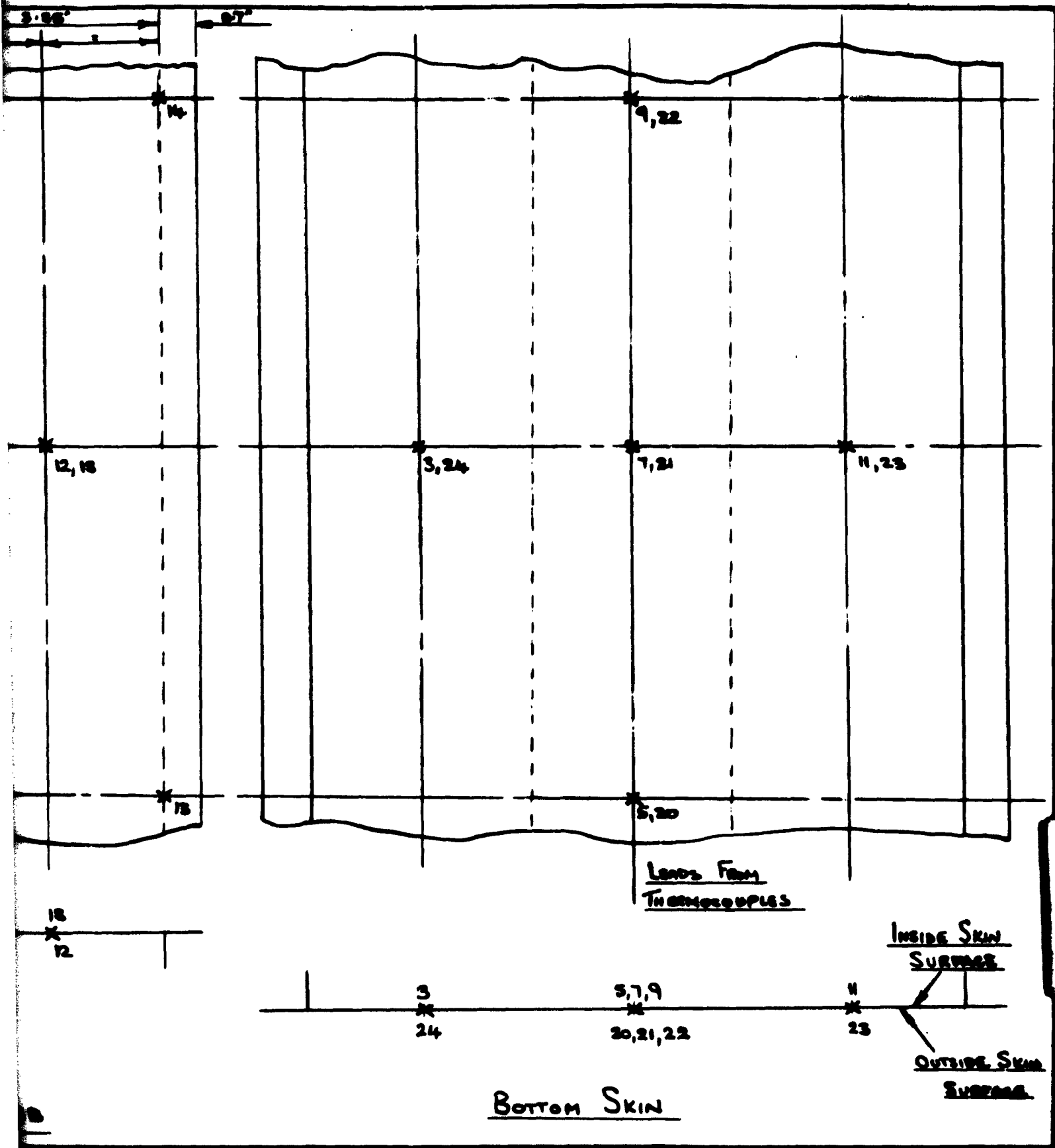

MS (I.C.I. 217) SPECS. 8,9 SEE TABLES A & F FOR BEAM TEMPERATURES.

FIG. 5

W.20A.

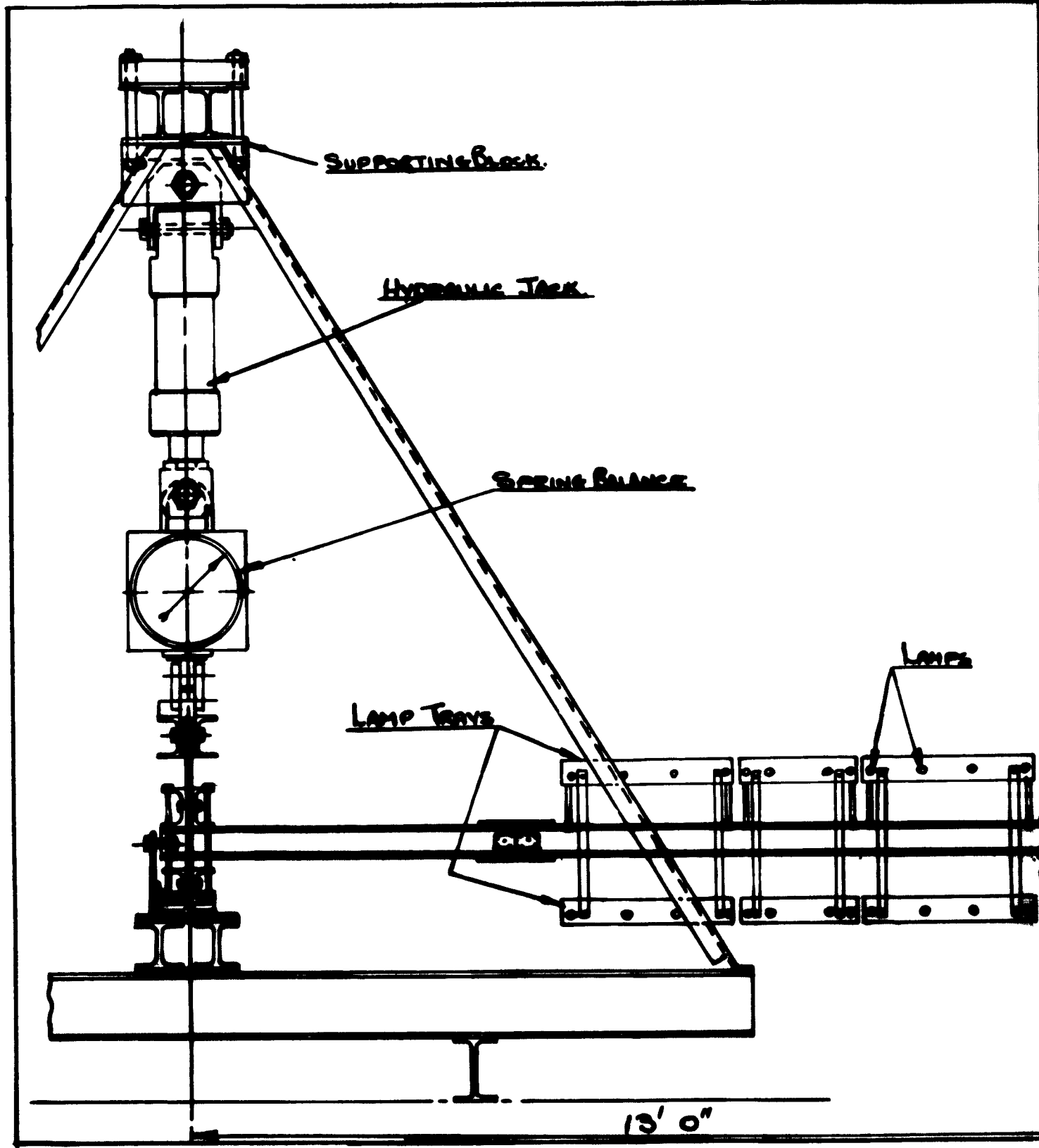

TORSION TEST RIG FOR TITANIUM & STEEL BOX

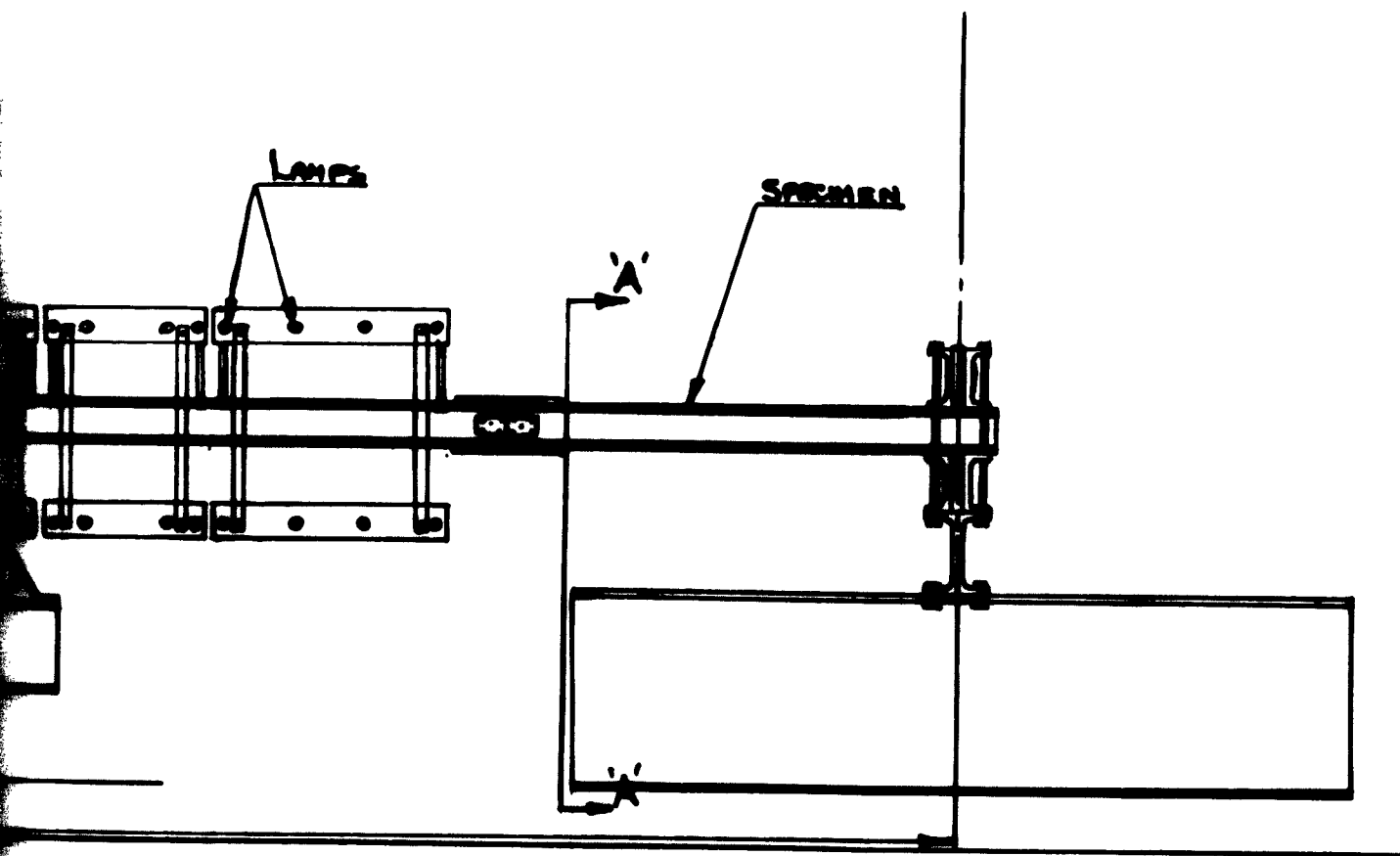

STEEL BOX BEAMS.

FIG
6

2

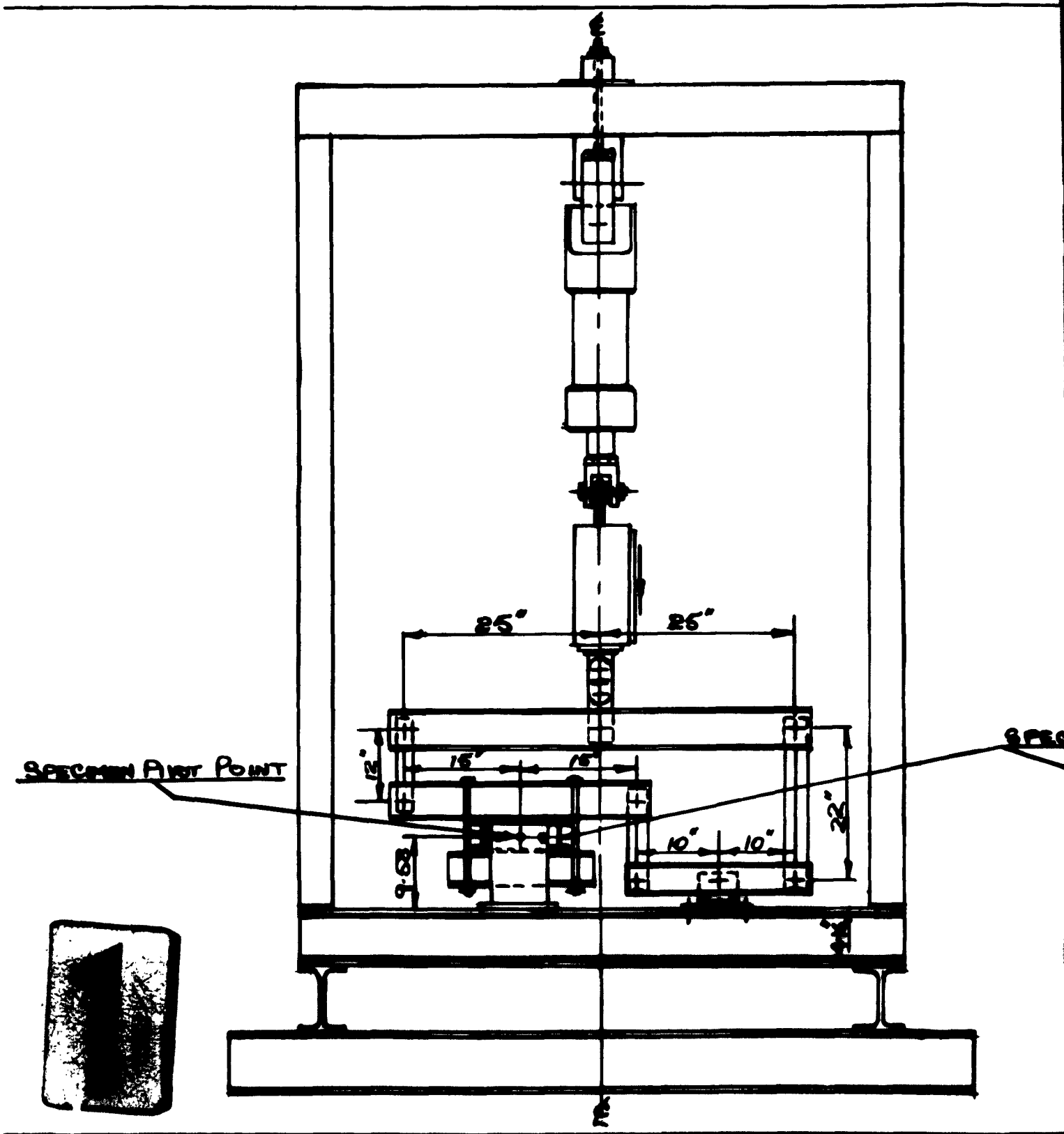

DRG. No. 15313

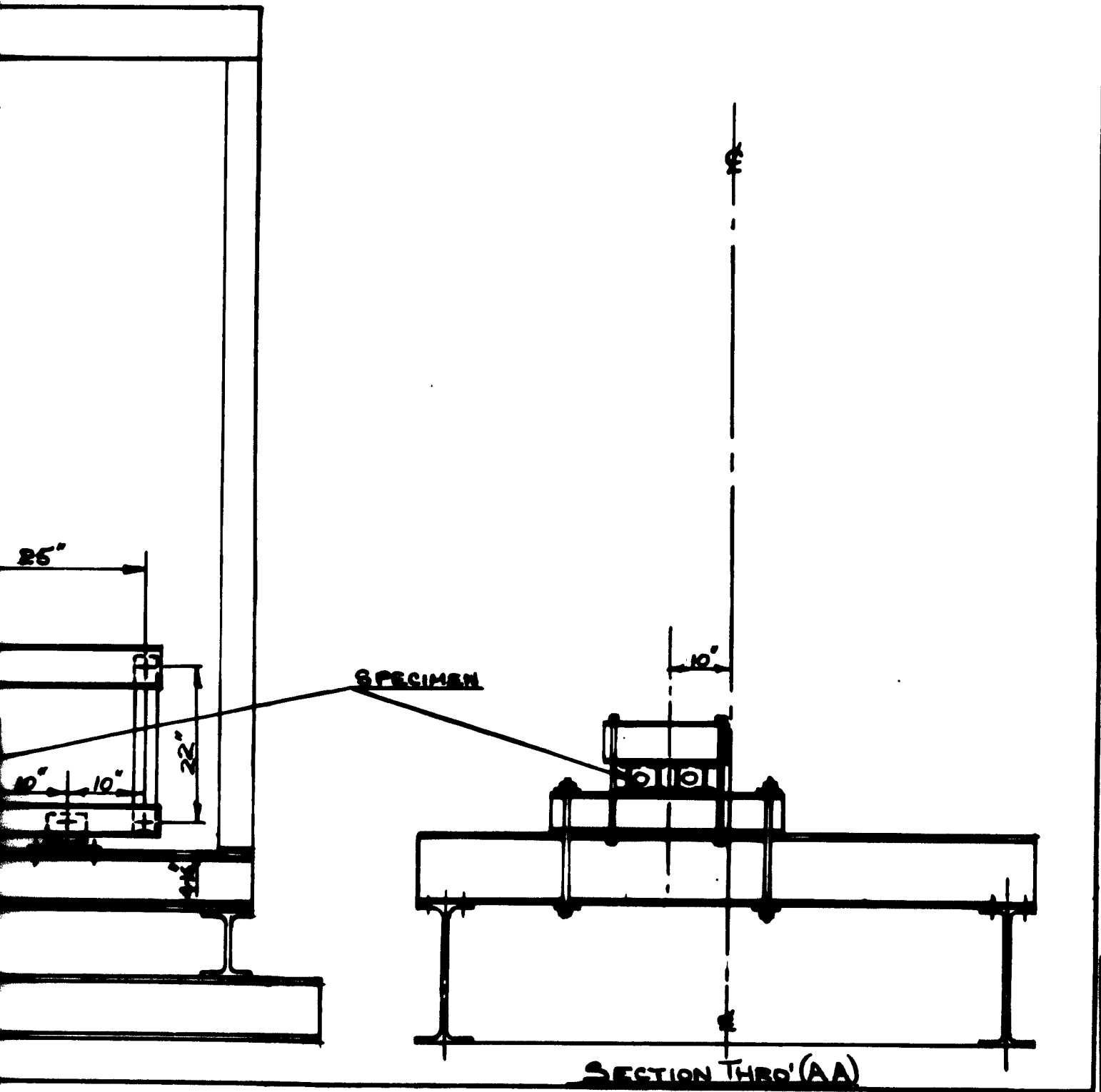

2

FIG
6A

DRG. No 14720

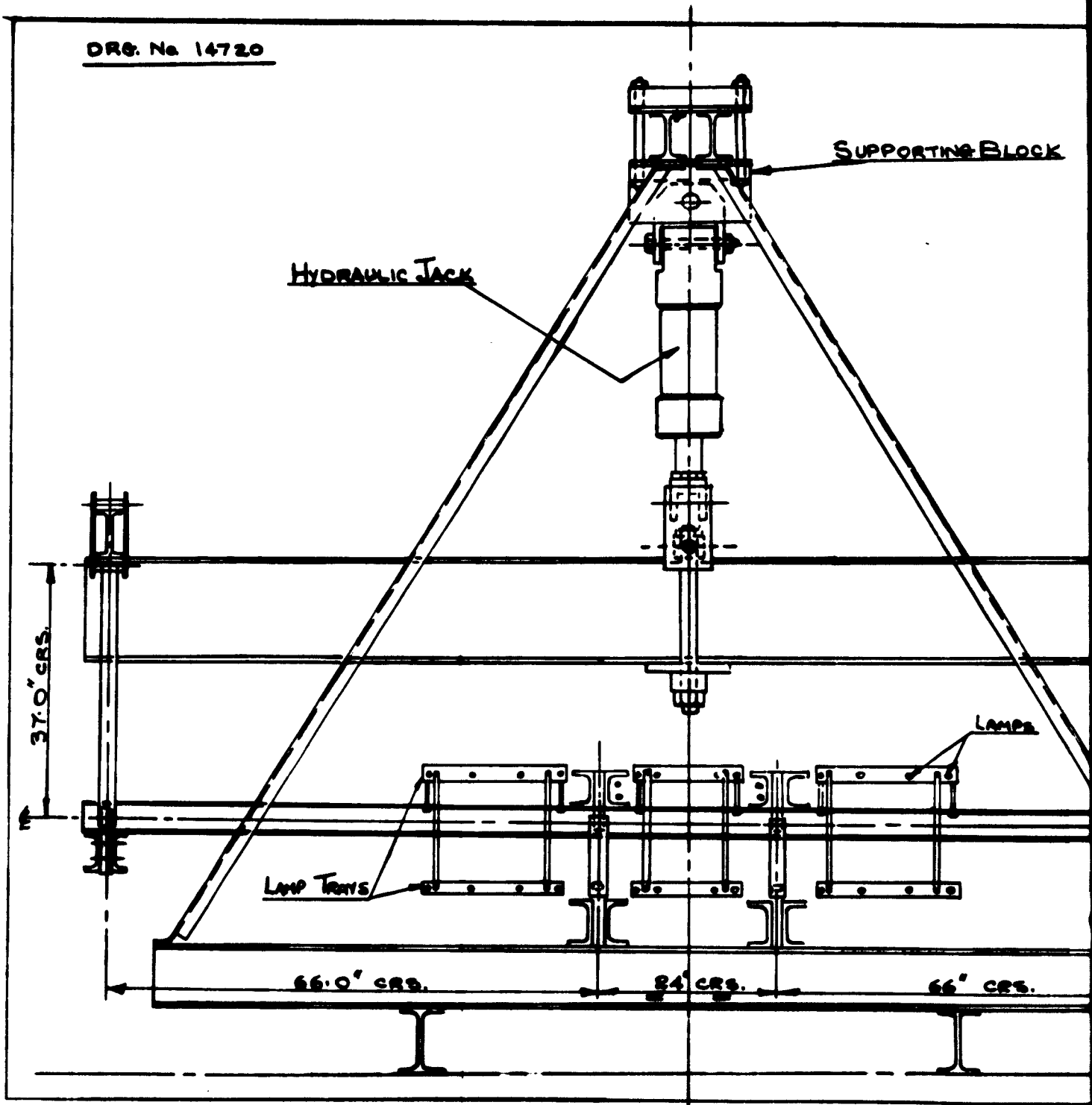

BENDING TEST RIG FOR TITANIUM & STEEL BOX BEAM

SUPPORTING BLOCK

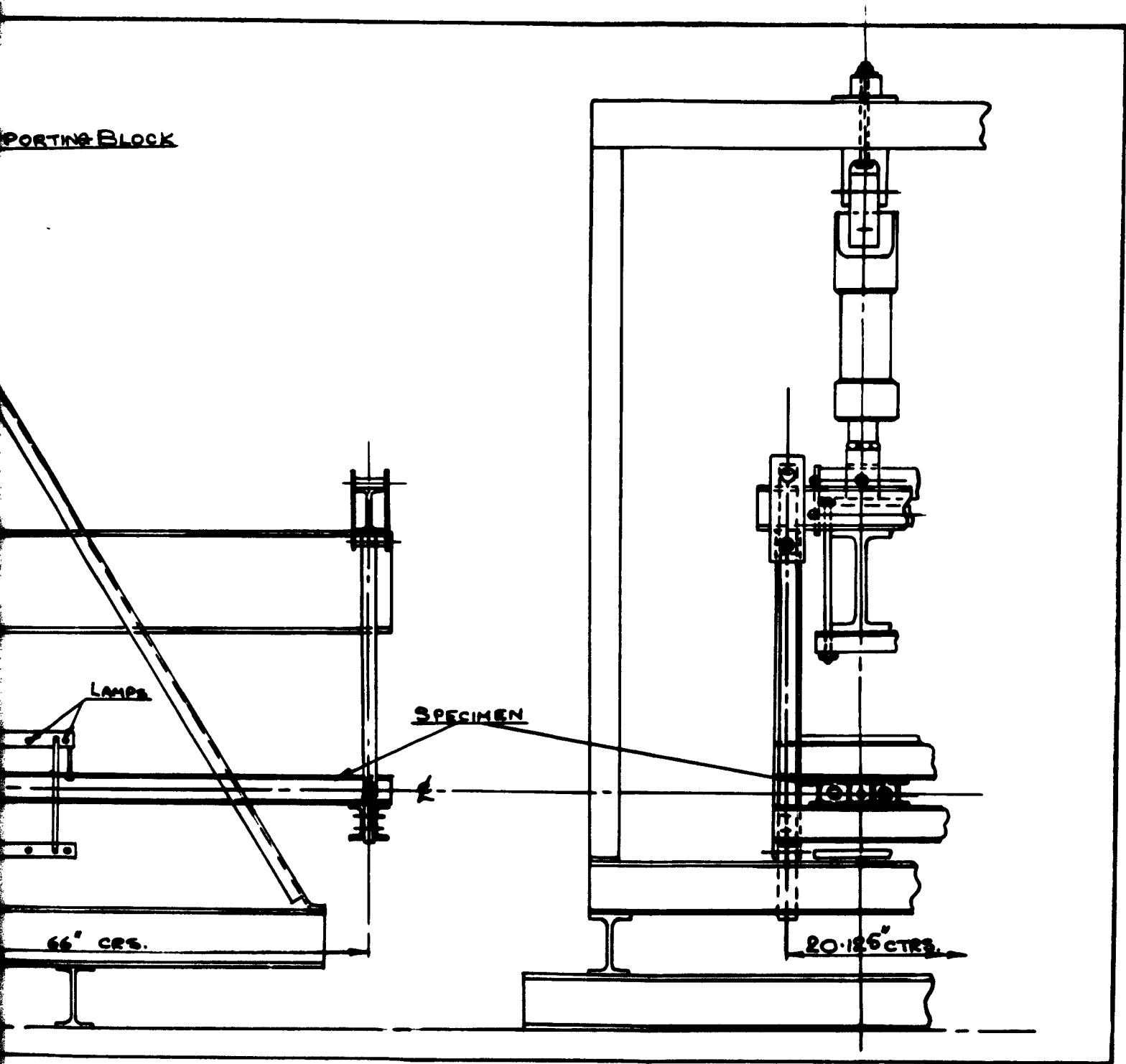

BOX BEAMS.

2

FIG. 7

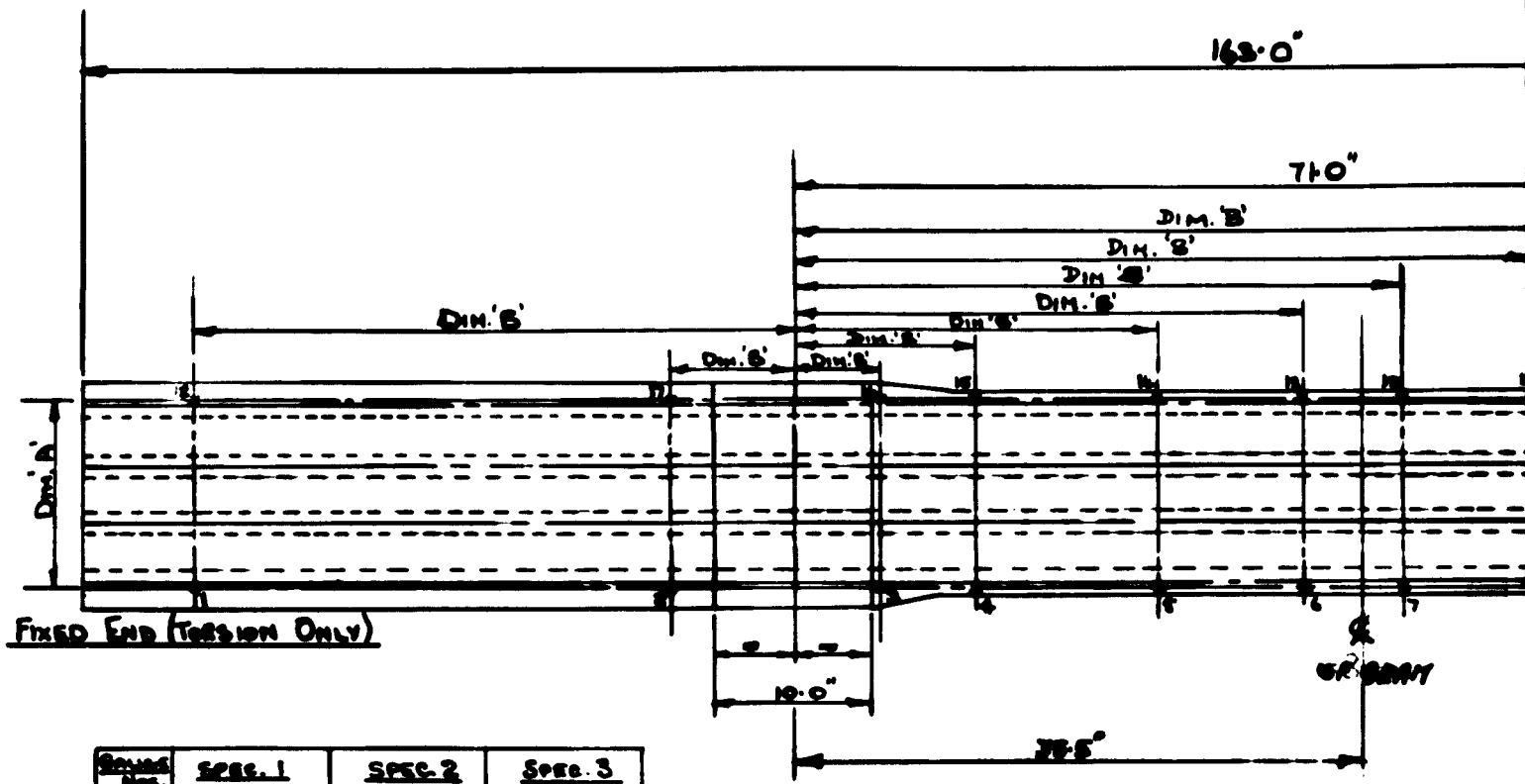

GAUGE NO.	SPEC. 1		SPEC. 2		SPEC. 3	
	DIM. A	DIM. B	DIM. A	DIM. B	DIM. A	DIM. B
1-18	11.1	38.65	11.2	38.7	11.2	38.5
2-17	"	8.0	11.5	8.0	11.25	7.9
3-16	"	6.0	9.6	6.25	11.2	6.5
4-15	"	11.6	11.1	11.5	11.15	11.5
5-14	"	25.9	11.4	25.5	11.3	23.2
6-13	"	32.3	11.5	31.75	11.35	32.4
7-12	"	35.7	11.4	35.75	11.3	35.6
8-11	"	45.1	11.2	47.5	11.2	47.1
9-10	"	54.6	11.2	54.5	11.15	54.5



DIAL GAUGE POSITIONS FOR MULTIVES BOX BEAMS (D.T.D. 166) SPECS. 1, 2 & 3

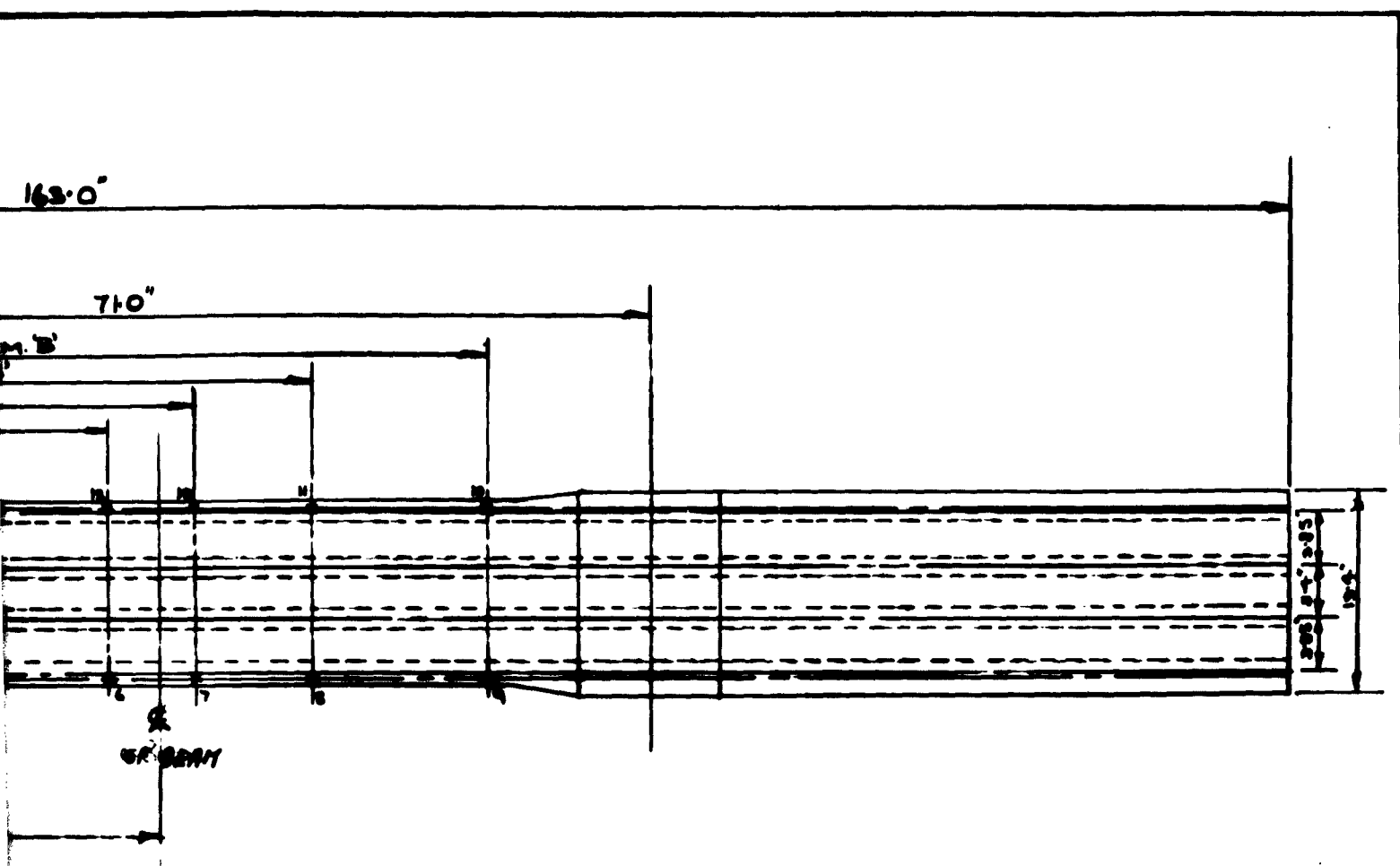

2

b) SPECS. 1,2 & 3 TORSION TESTS.

8

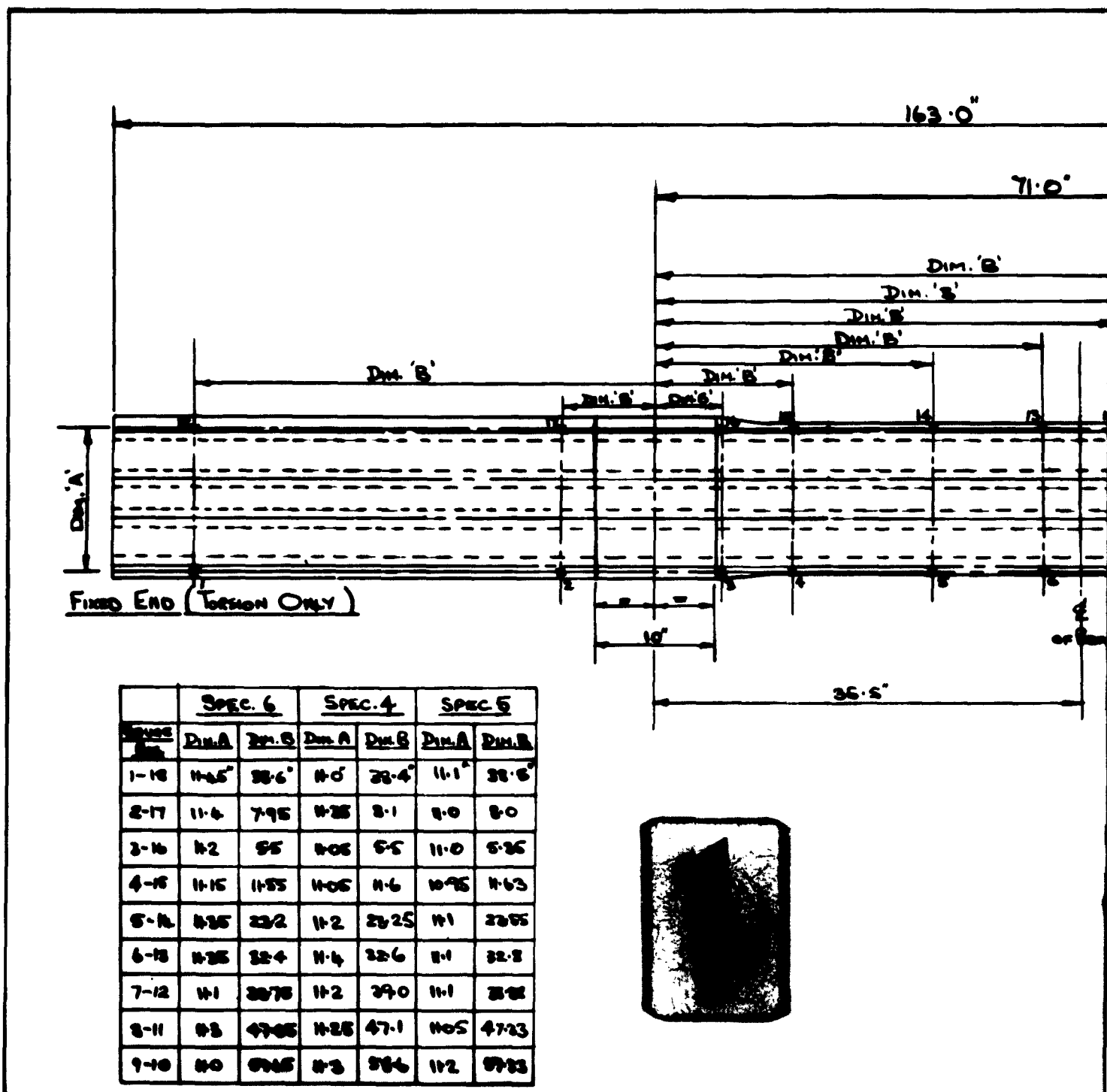

DIAL GAUGE POSITIONS FOR MULTIBES, BOX BEAMS (FIRM)

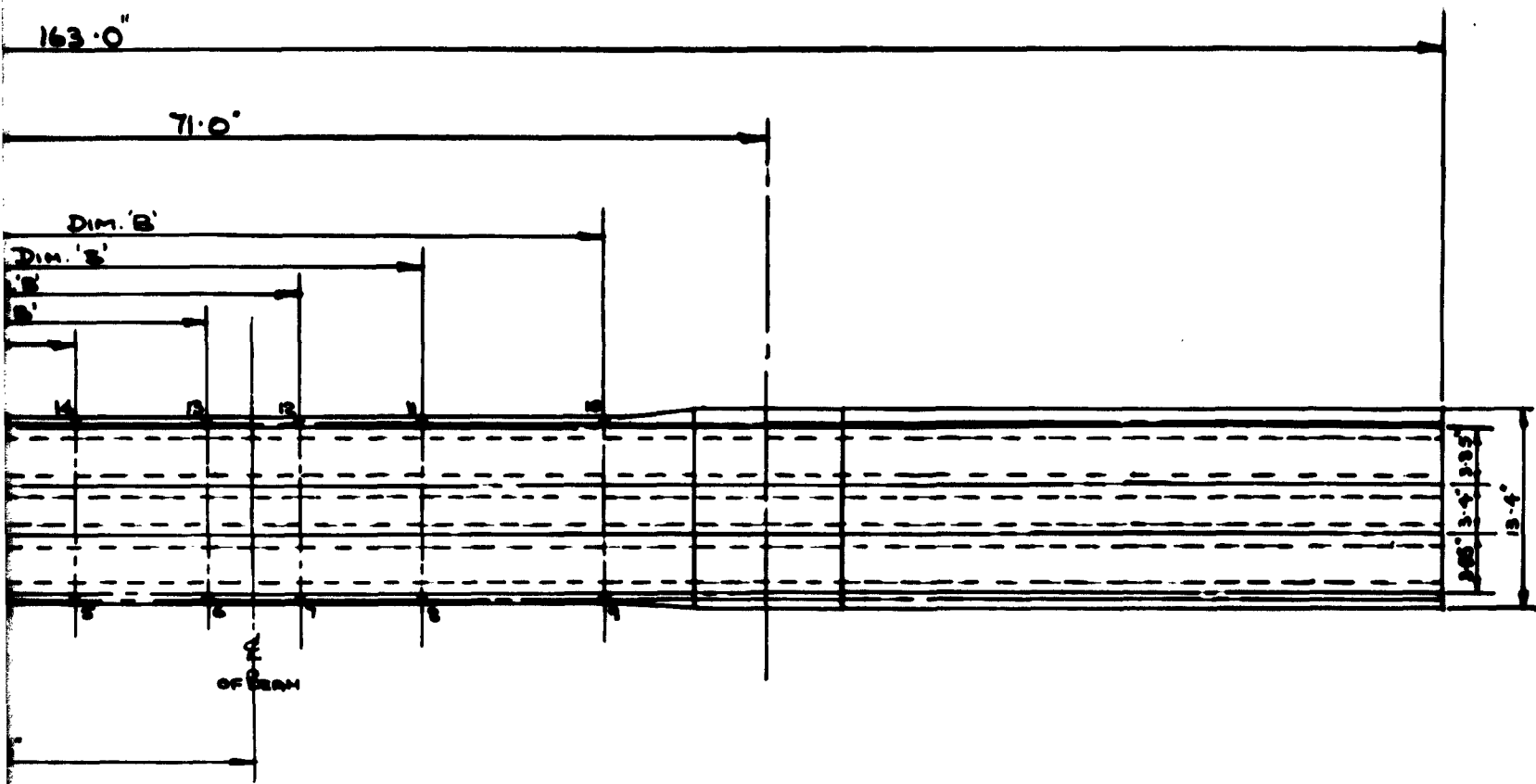

2

10x BEAMS (FIRTH VICKERS 520) SPECS. 4.5 & 6 TORSION TESTS

FIG. 9

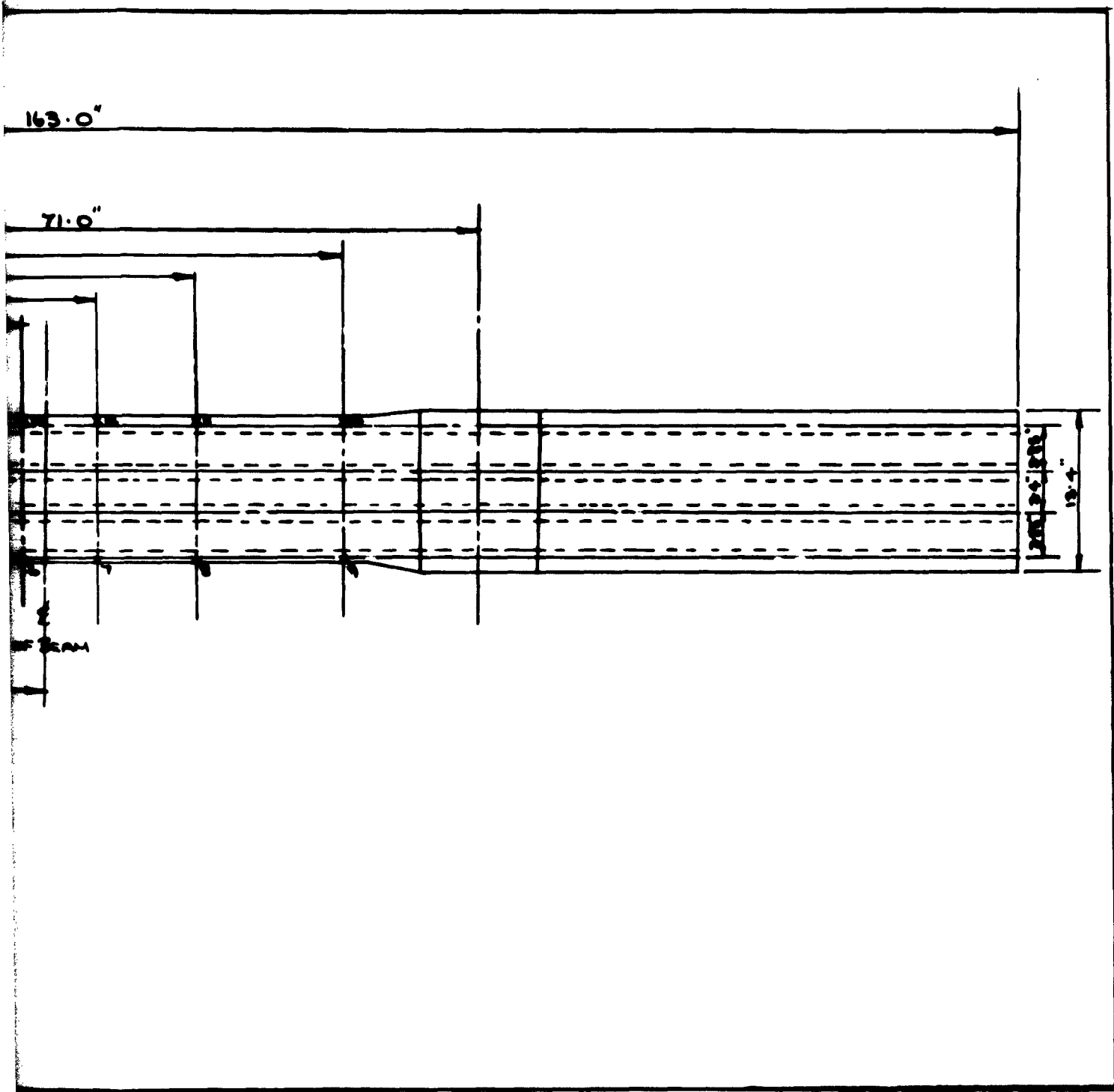

ALLOY (101 217) SPECS. 729

TORSION TESTS.

10



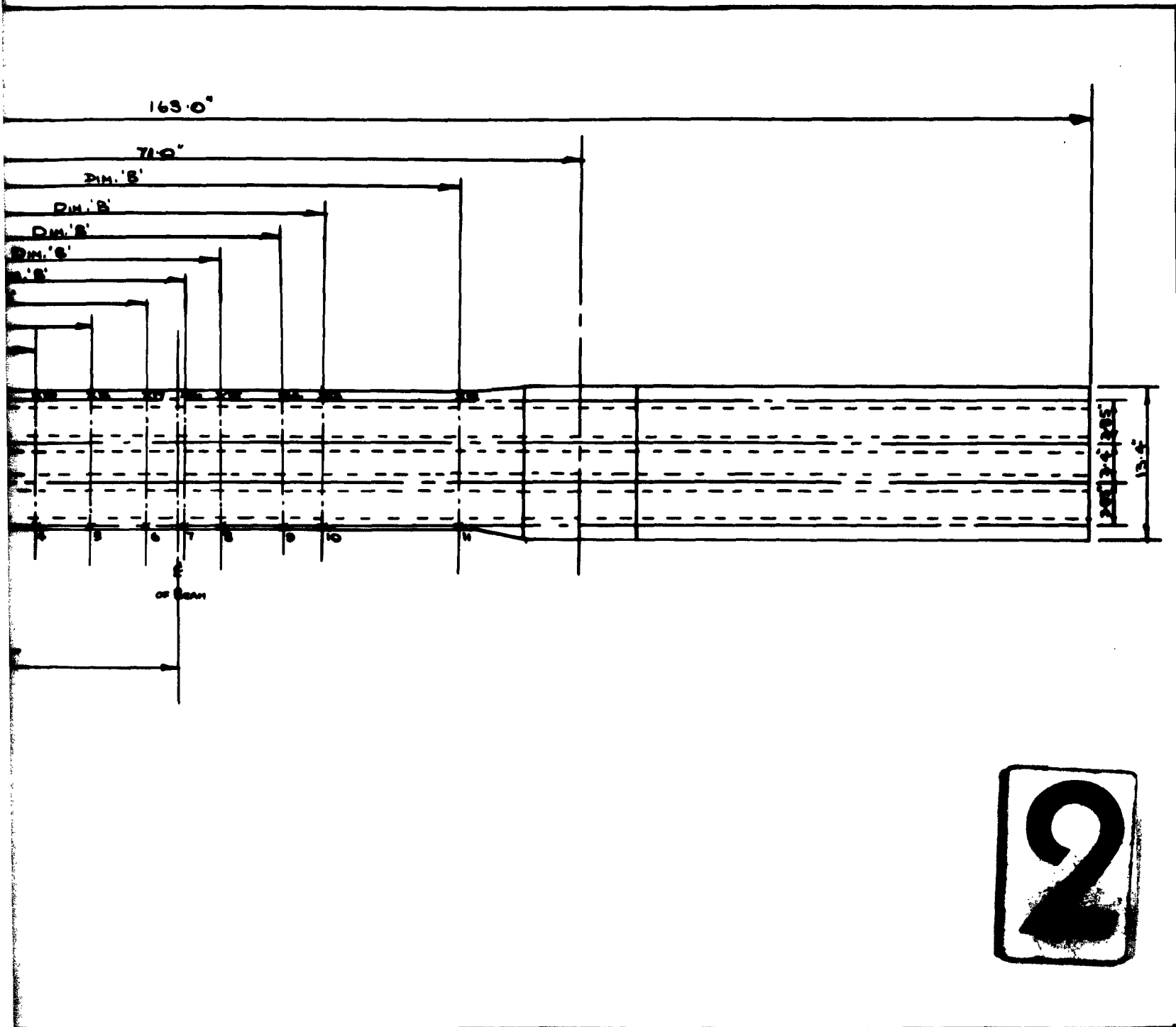

2

3. SPECIMEN 8: TORSION TESTS.

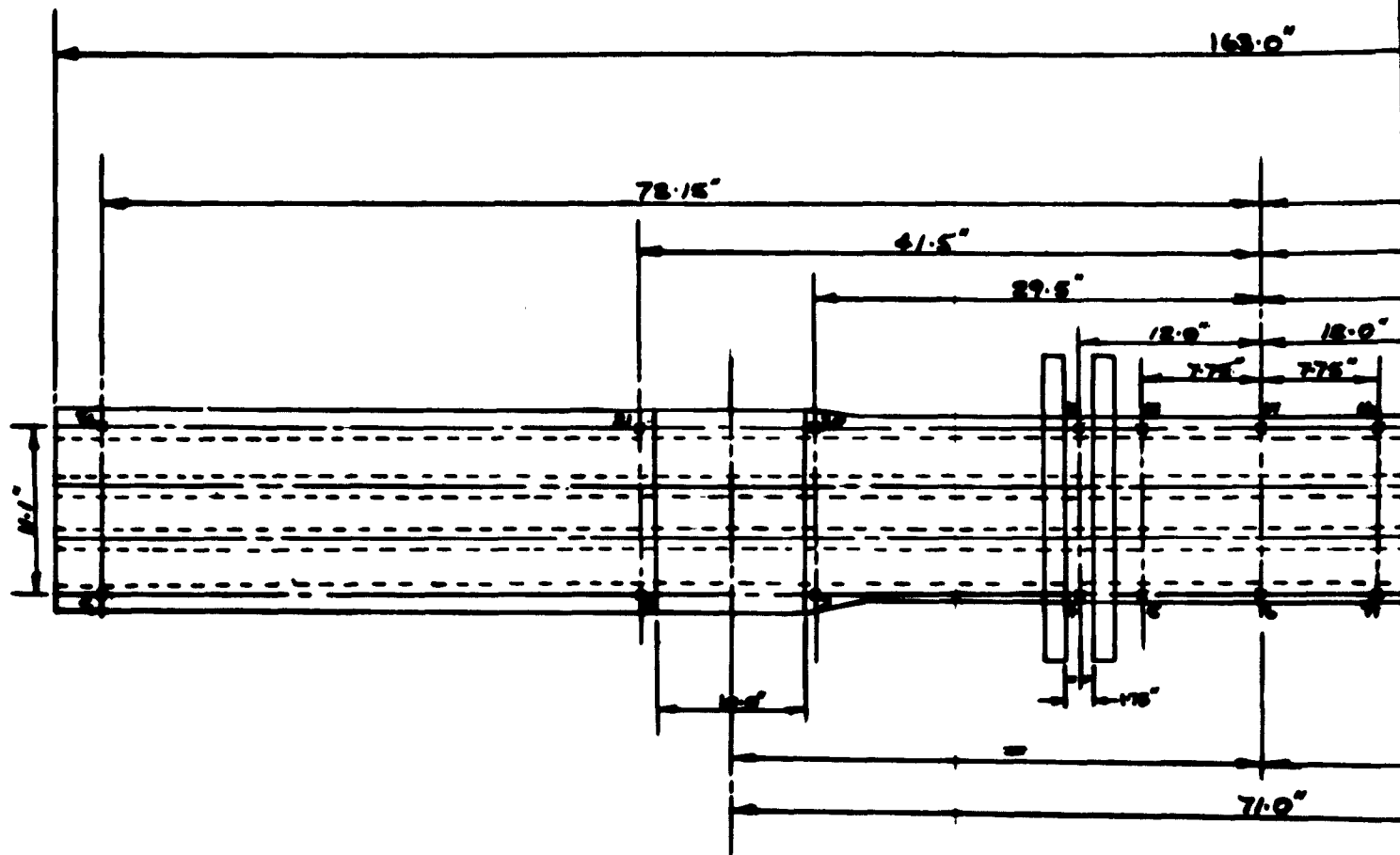

DIAL GAUGE POSITIONS FOR MULTIWEB BOX BEAMS (D.T.D. 166) SPEC. 1

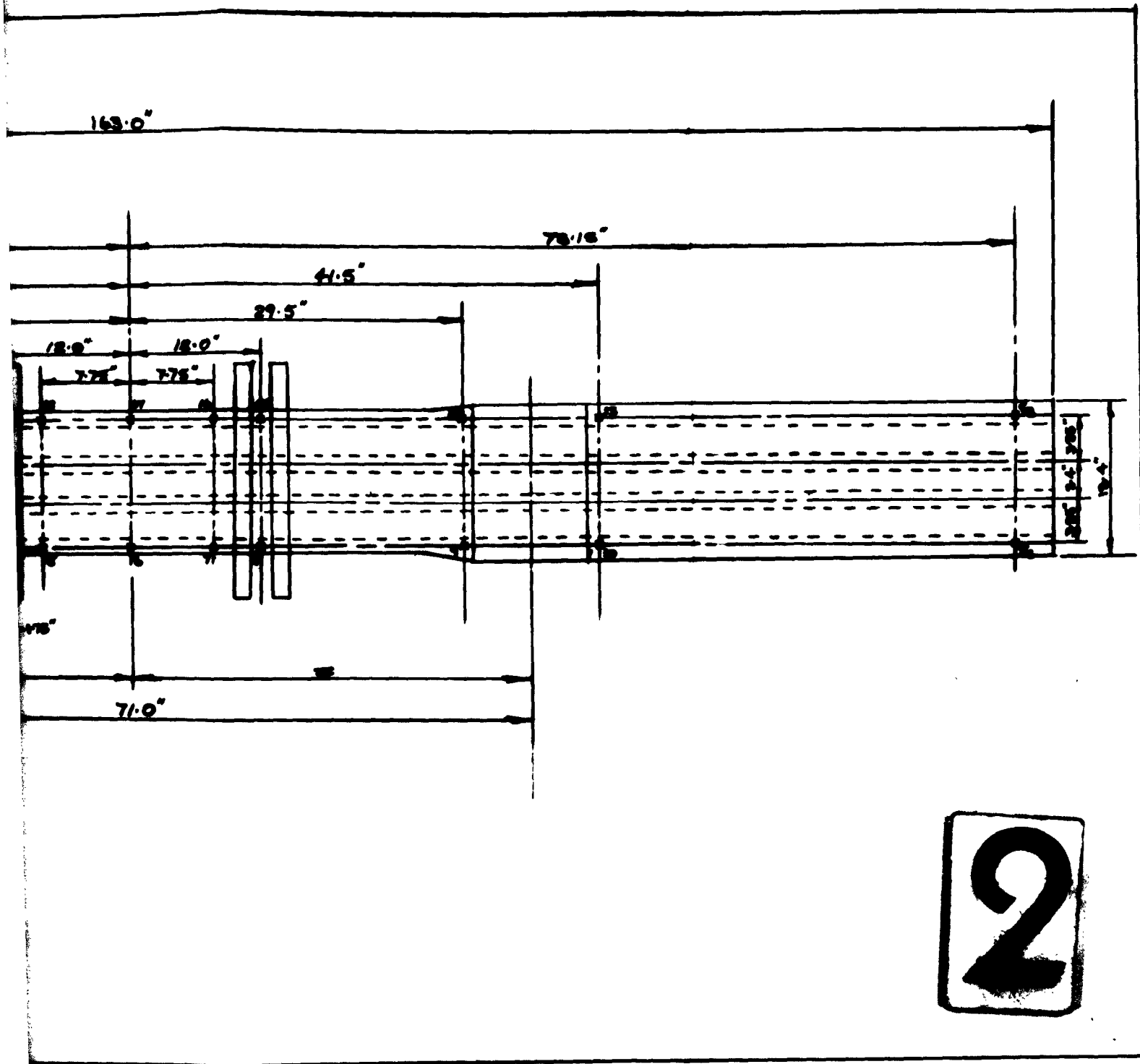

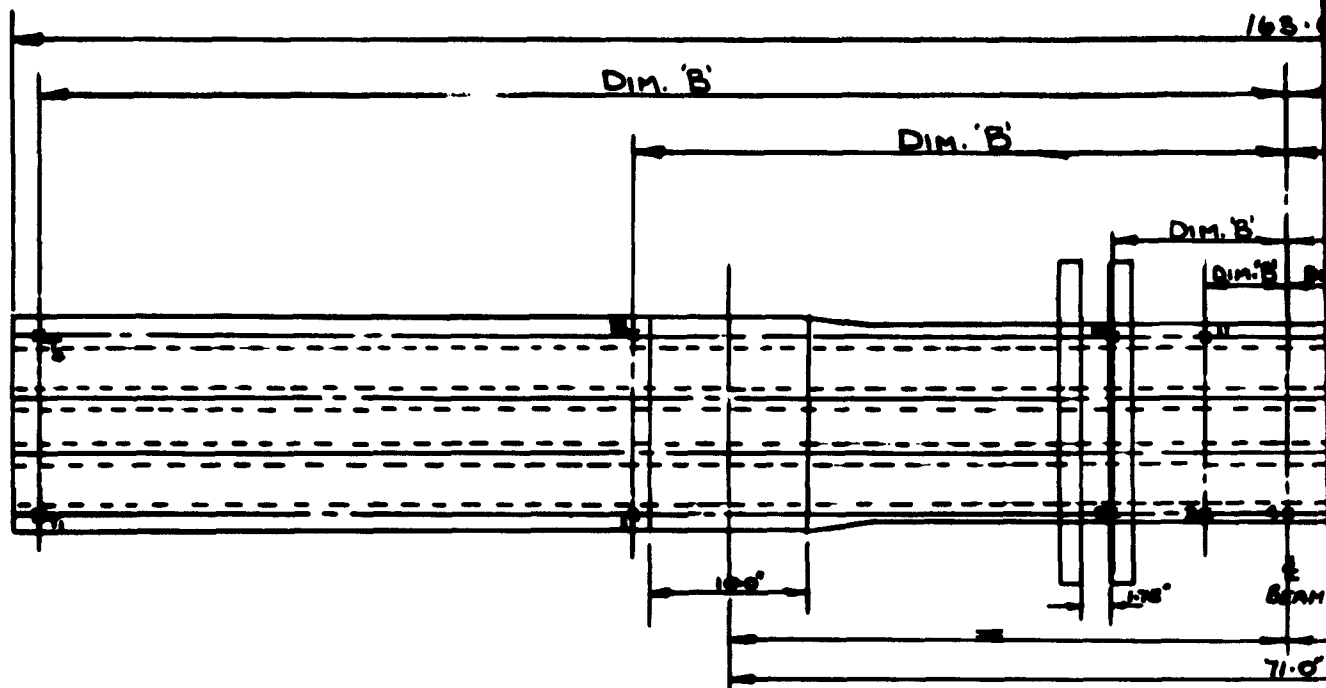

	DIM 'B'				
Spec. 2	Spec. 3	Spec. 4	Spec. 5	Spec. 6	Spec. 7
T ₁ -T ₂	80.6	80.6	80.26	80.68	80.275
1-10	41.25	41.4	41.3	41.52	42.24
2-12	10.73	10.8	10.60	10.85	10.08
3-11	3.23	3.2	2.90	3.35	3.075
5-10	3.23	3.2	3.20	3.10	2.375
6-9	10.73	10.8	11.10	10.7	10.98
7-8	41.26	42.0	41.65	41.4	42.85
T ₂ -T ₃	80.44	80.5	80.35	80.5	80.175



DIAL GAUGE POSITIONS FOR MULTIWEB BOX BEAMS SPEC. 2.3

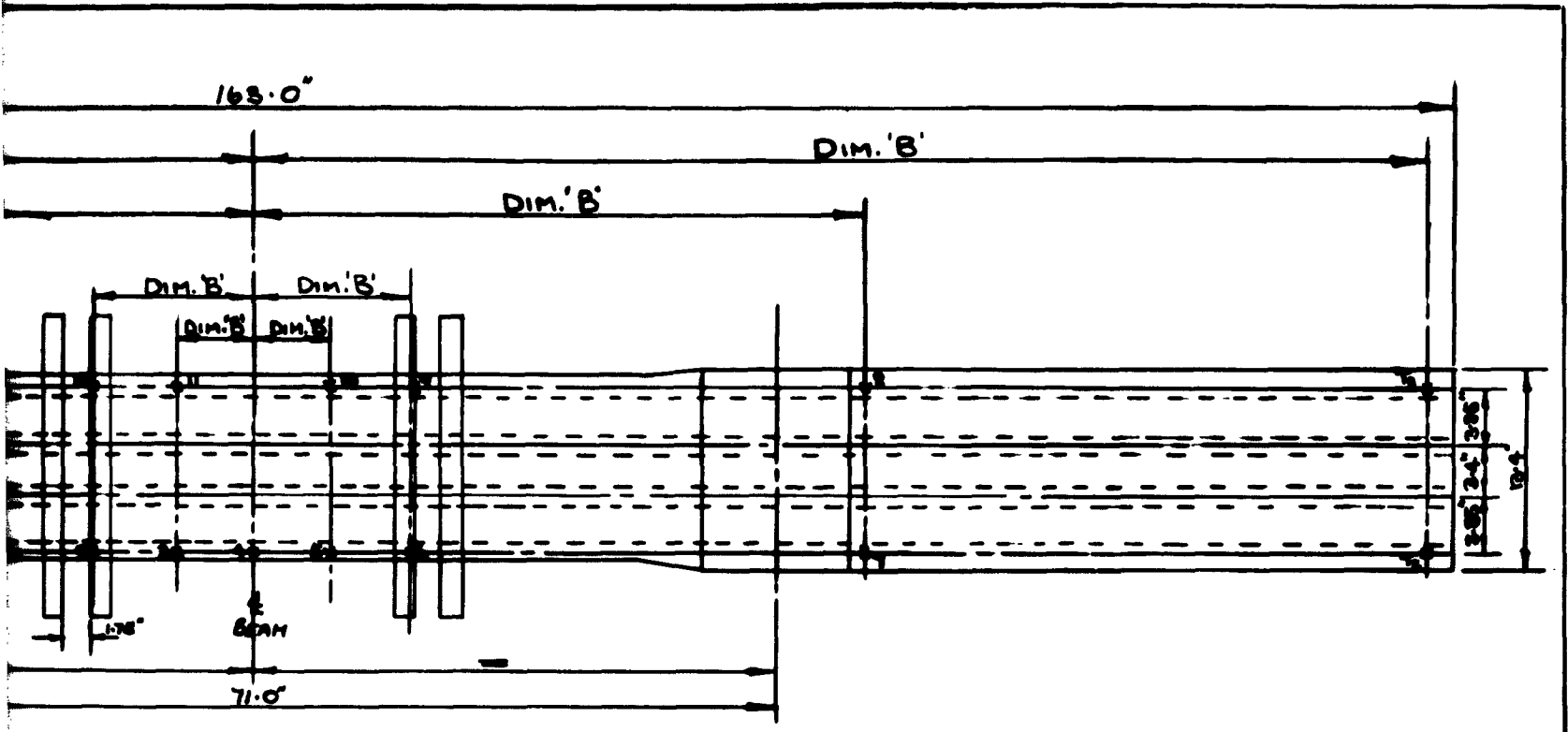

2

BENDING TESTS

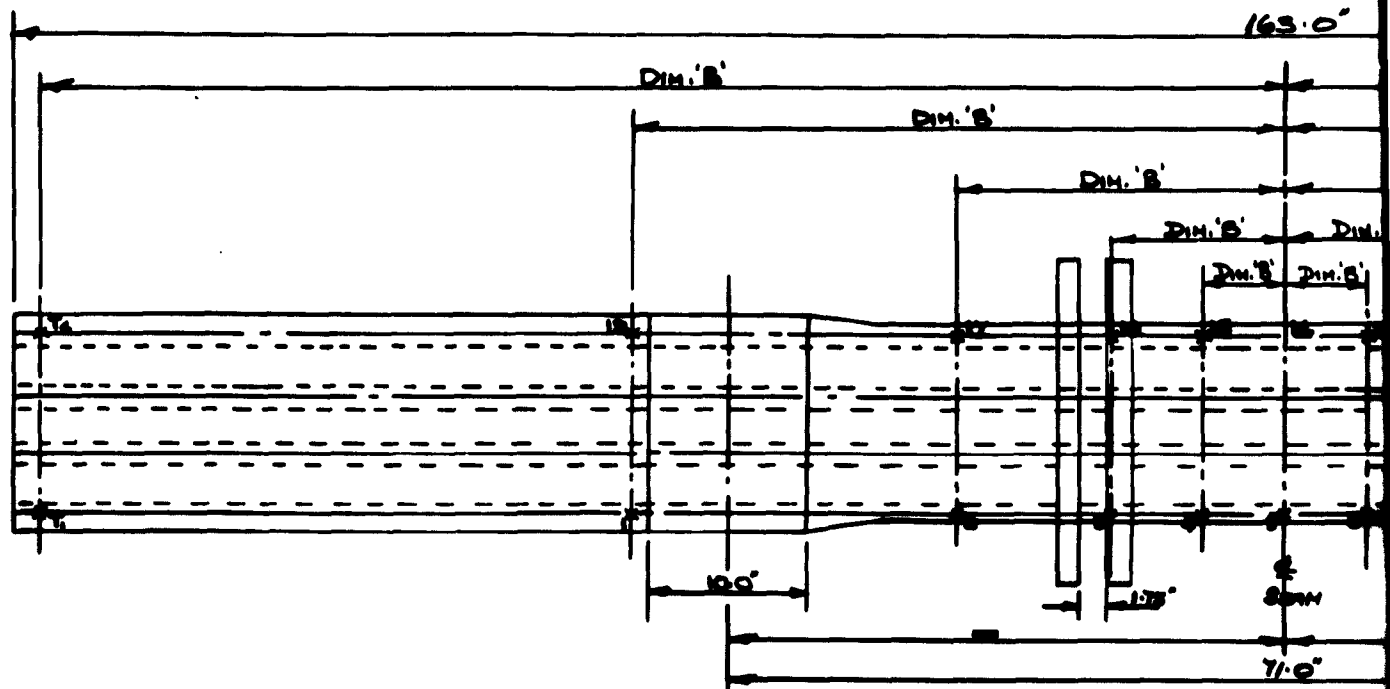

Gauge Loc.	DIM. 'B'		
	Spec. 7	Spec. 8	Spec. 9
T-T ₄	80.6	80.7	80.25
1-18	41.53	39.55	41.5
2-17	24.95	25.3	25.5
3-16	18.25	16.75	16.75
4-15	3.1	3.45	3.975
5-14	0	0	0
6-13	3.25	2.65	3.325
7-12	18.3	16.725	16.75
8-11	24.31	23.7	23.4
9-10	41.85	41.3	41.3
T-T ₃	80.5	80.4	80.2



DIAL GAUGE POSITIONS FOR MULTIRIBBED BOX BEAMS SPEC. 7.22

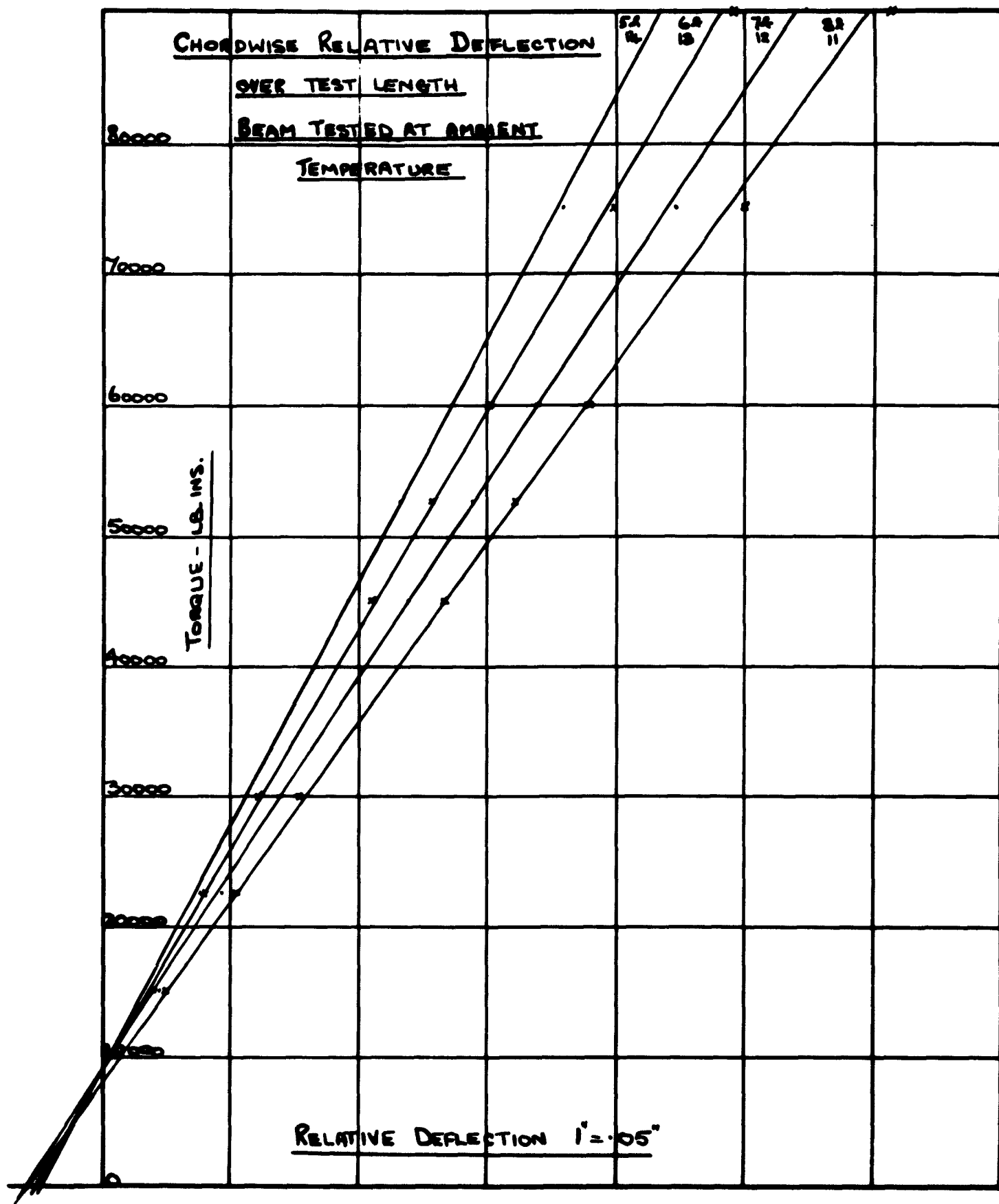

TORSION TEST ON BOX BEAMS (D.T.D. 146) SPEC. 1. FG. 15

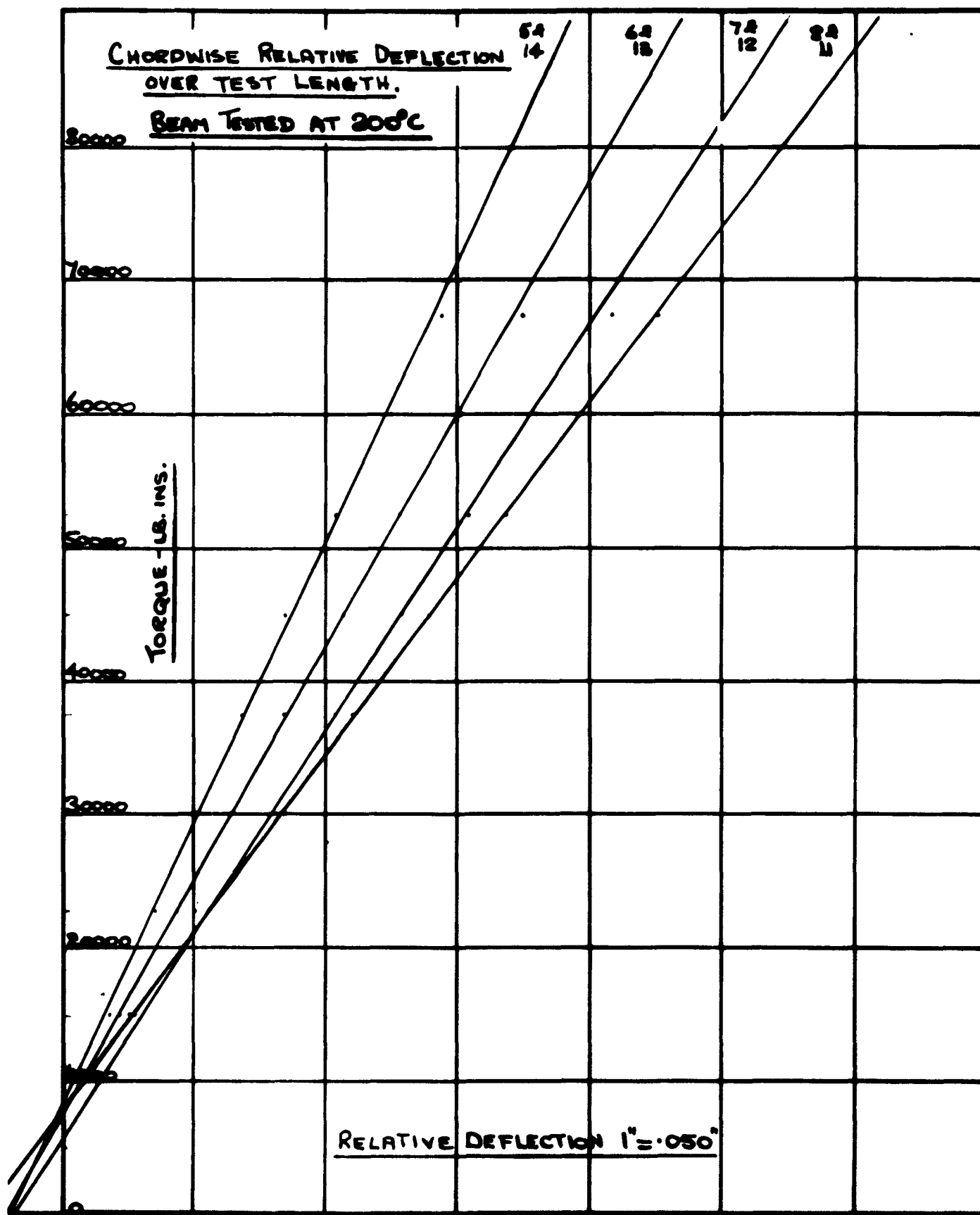

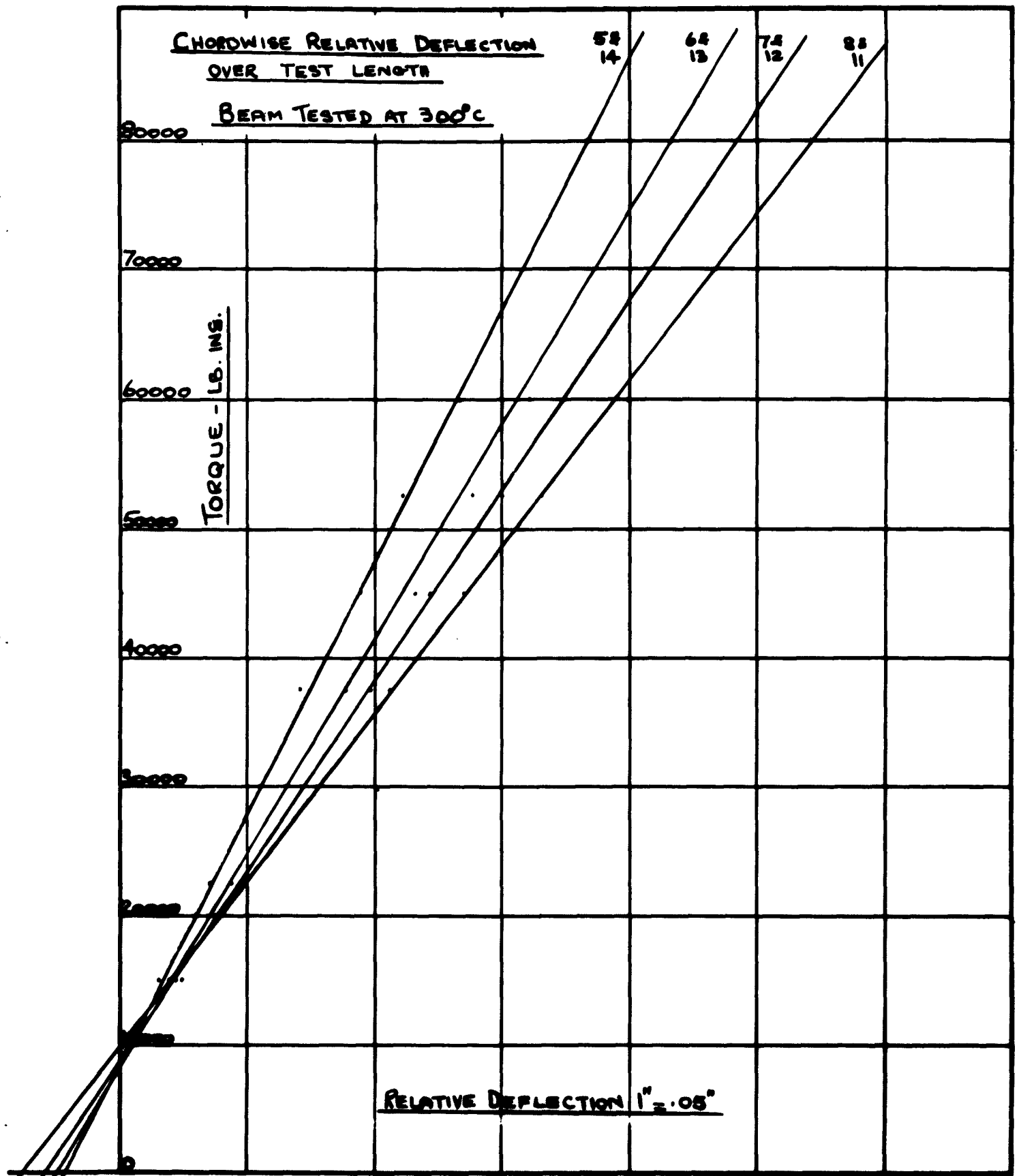

TORSION TEST ON BOX BEAMS (D.T.D. 166) SPEC. 3

FIG.
17

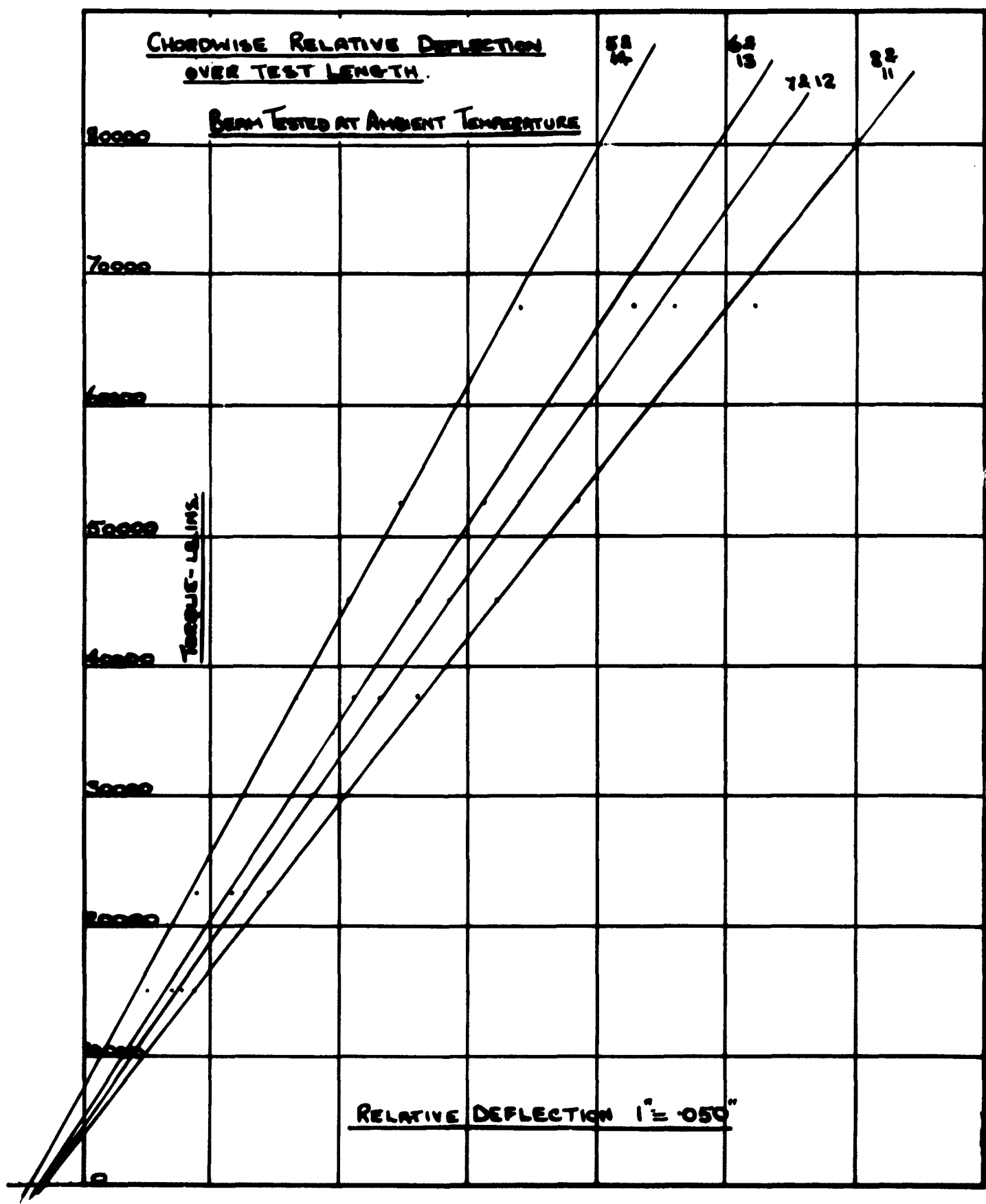

TORSION TEST ON BOX BEAMS (FIRTH VICKERS 520) SPEC. 4 | PG 18

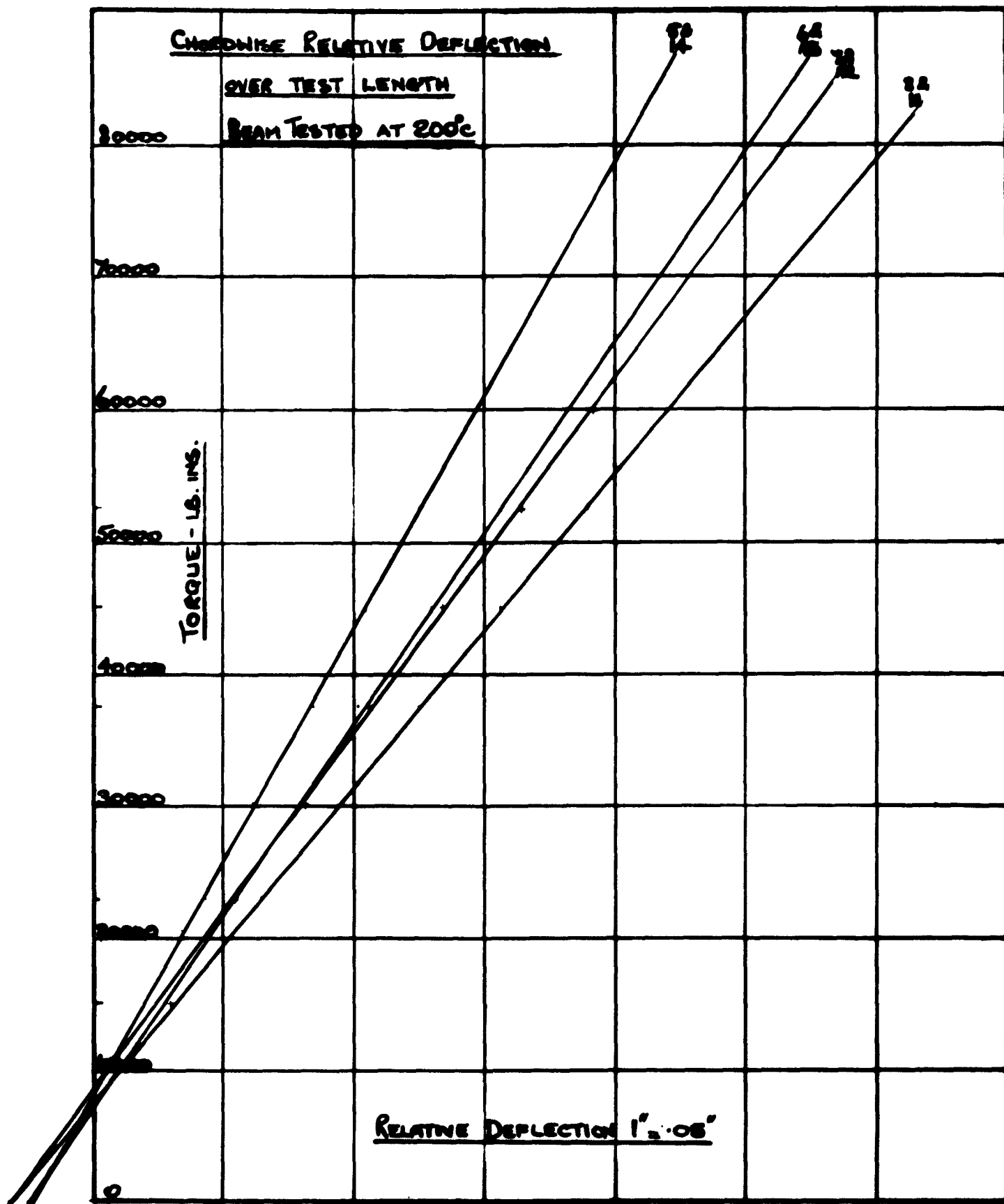

TORSION TEST ON BOX BEAMS (FIRTH VICKERS 520) SPEC. 5

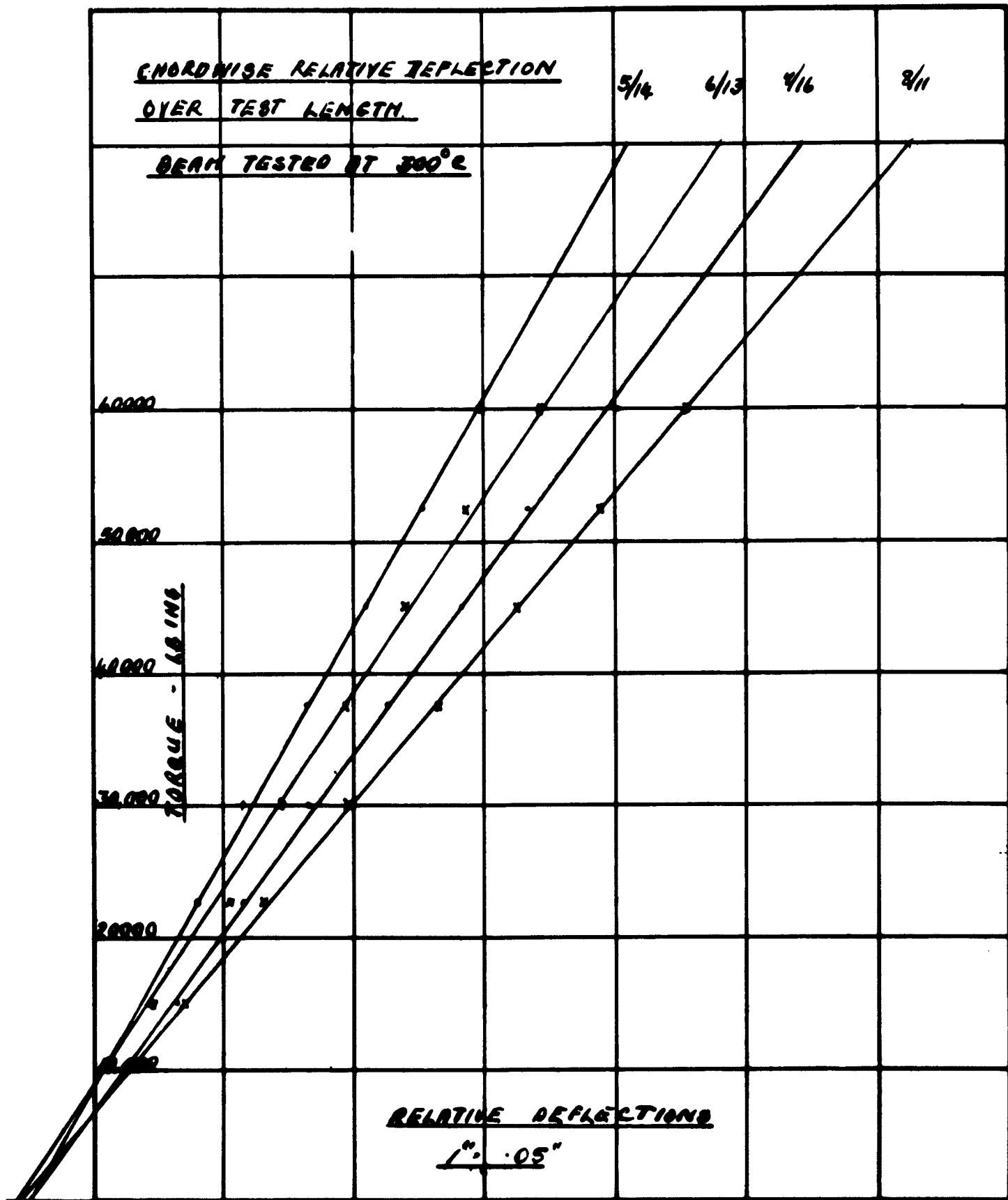

TORSION TESTS ON BOX BEAMS (FIRST VICKERS 920) SPEC 6

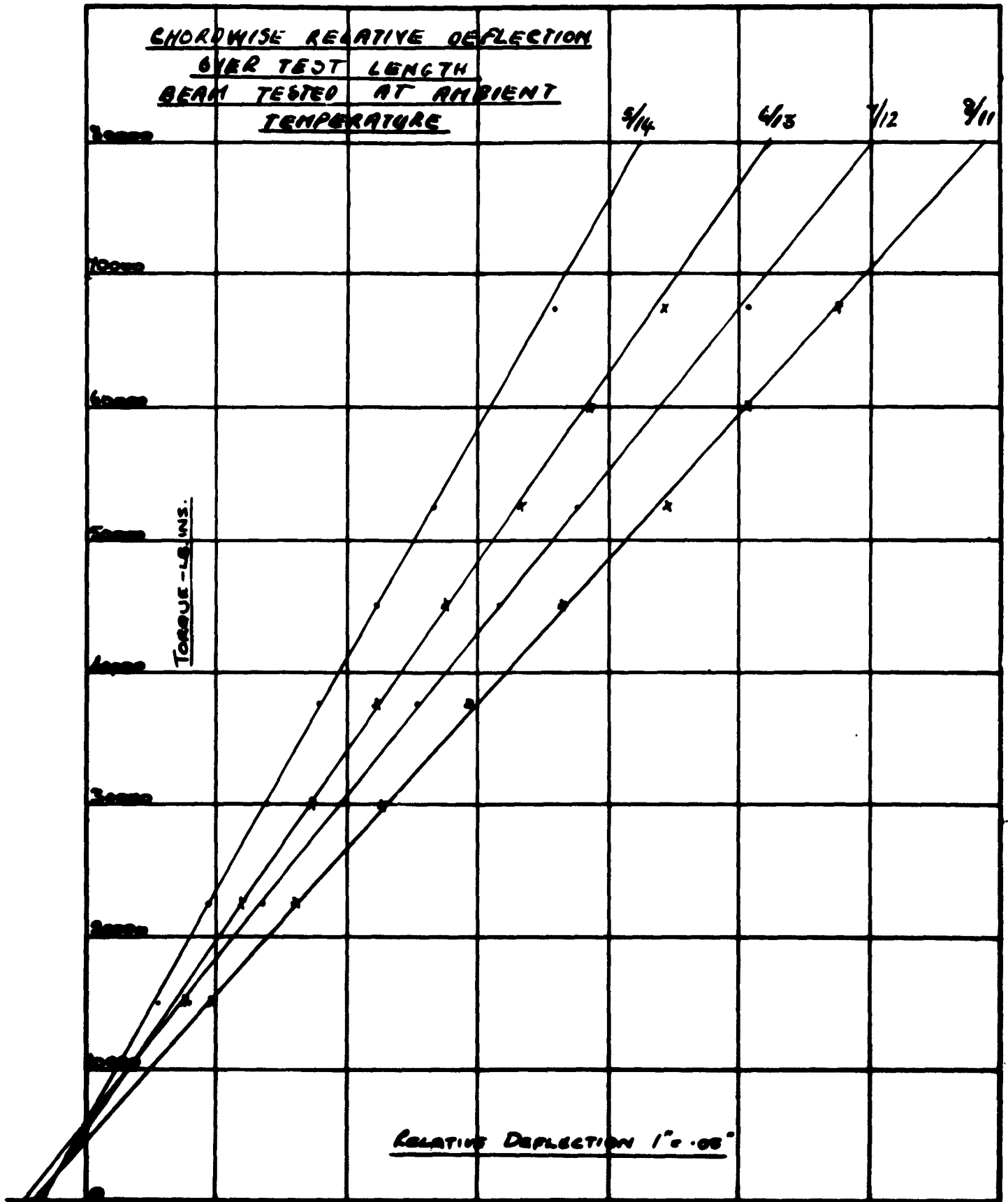

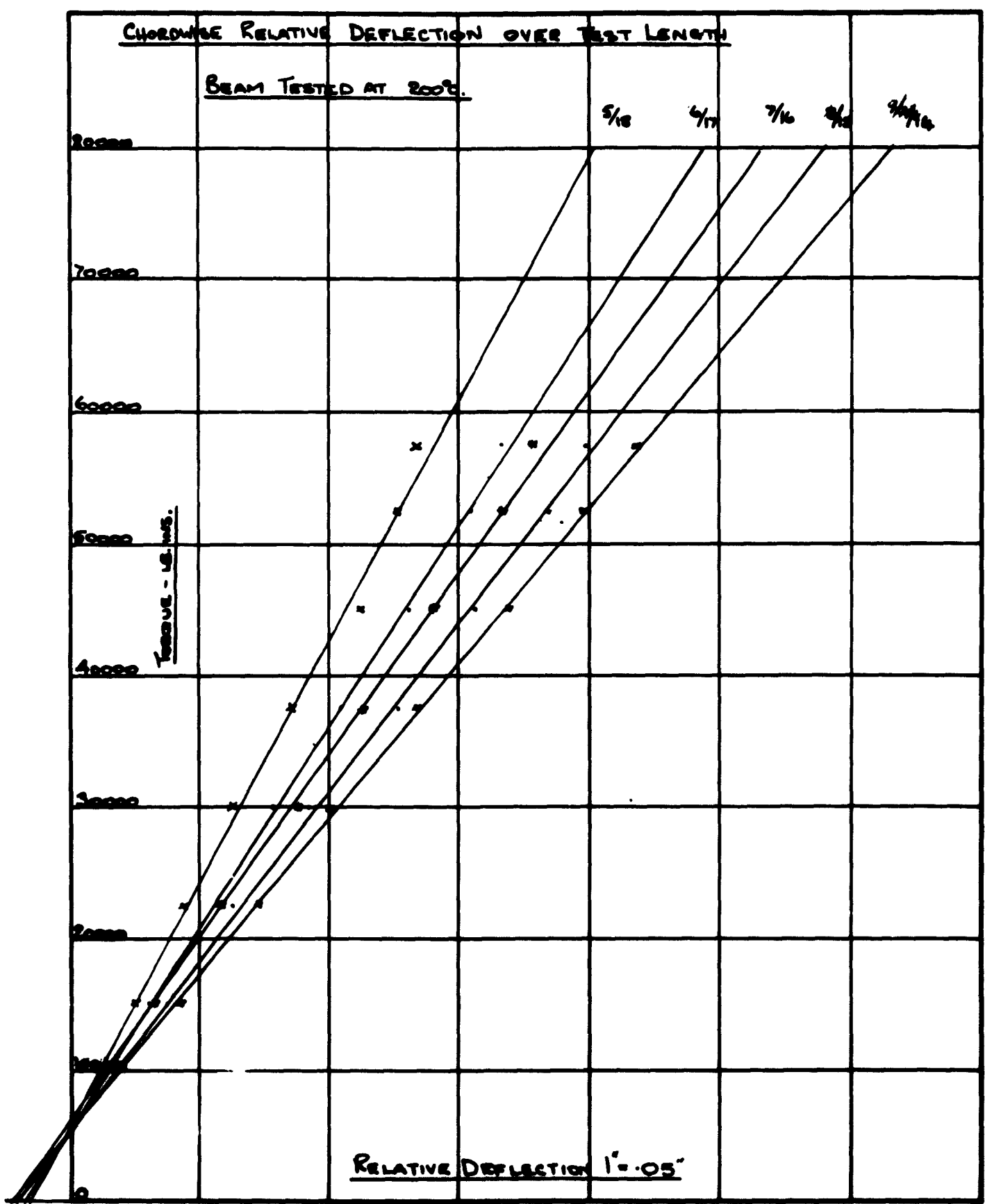

TORSION TEST ON BOX BEAMS (I.C.I. 717) SPEC. No. 8. FG. 22

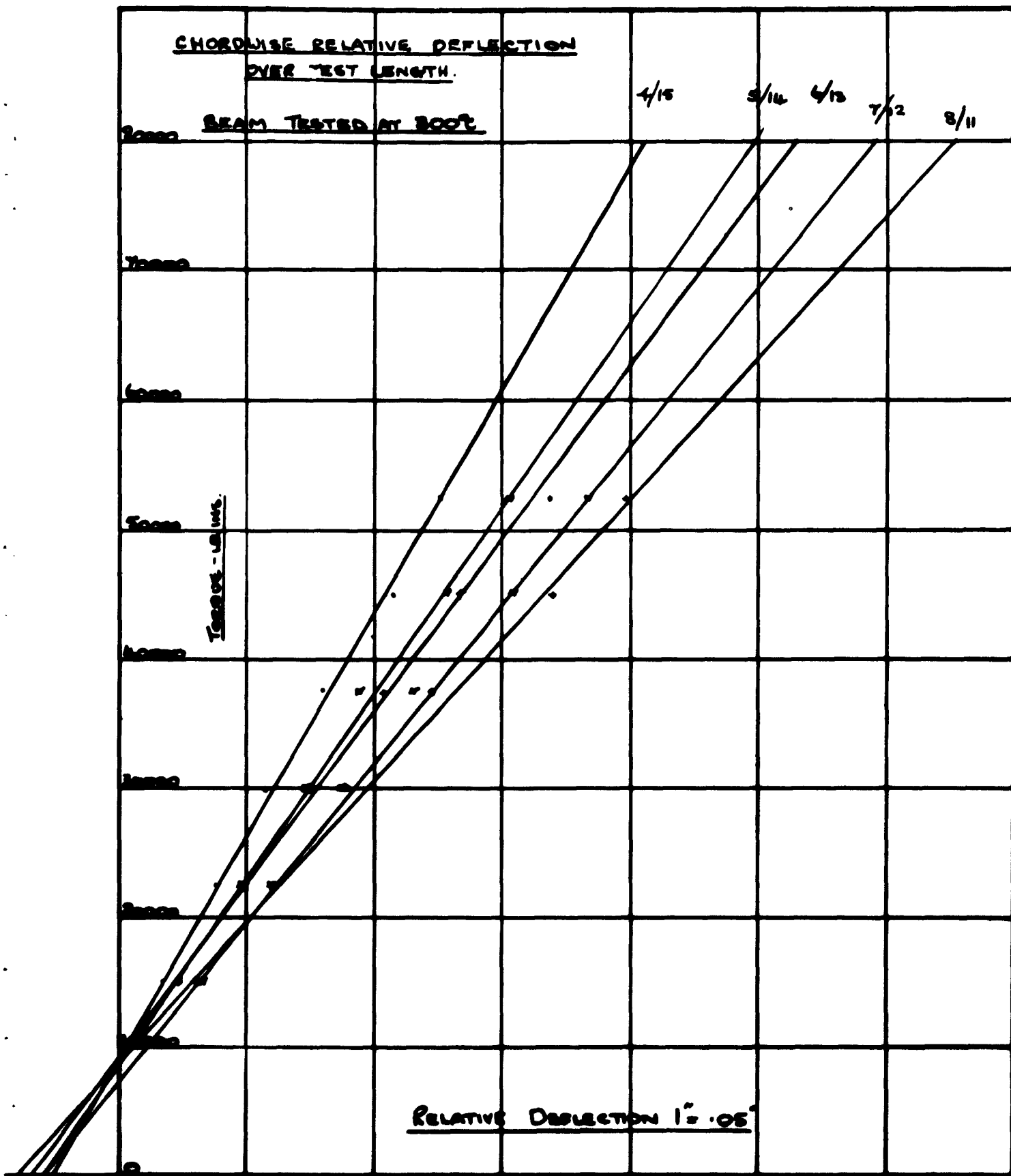

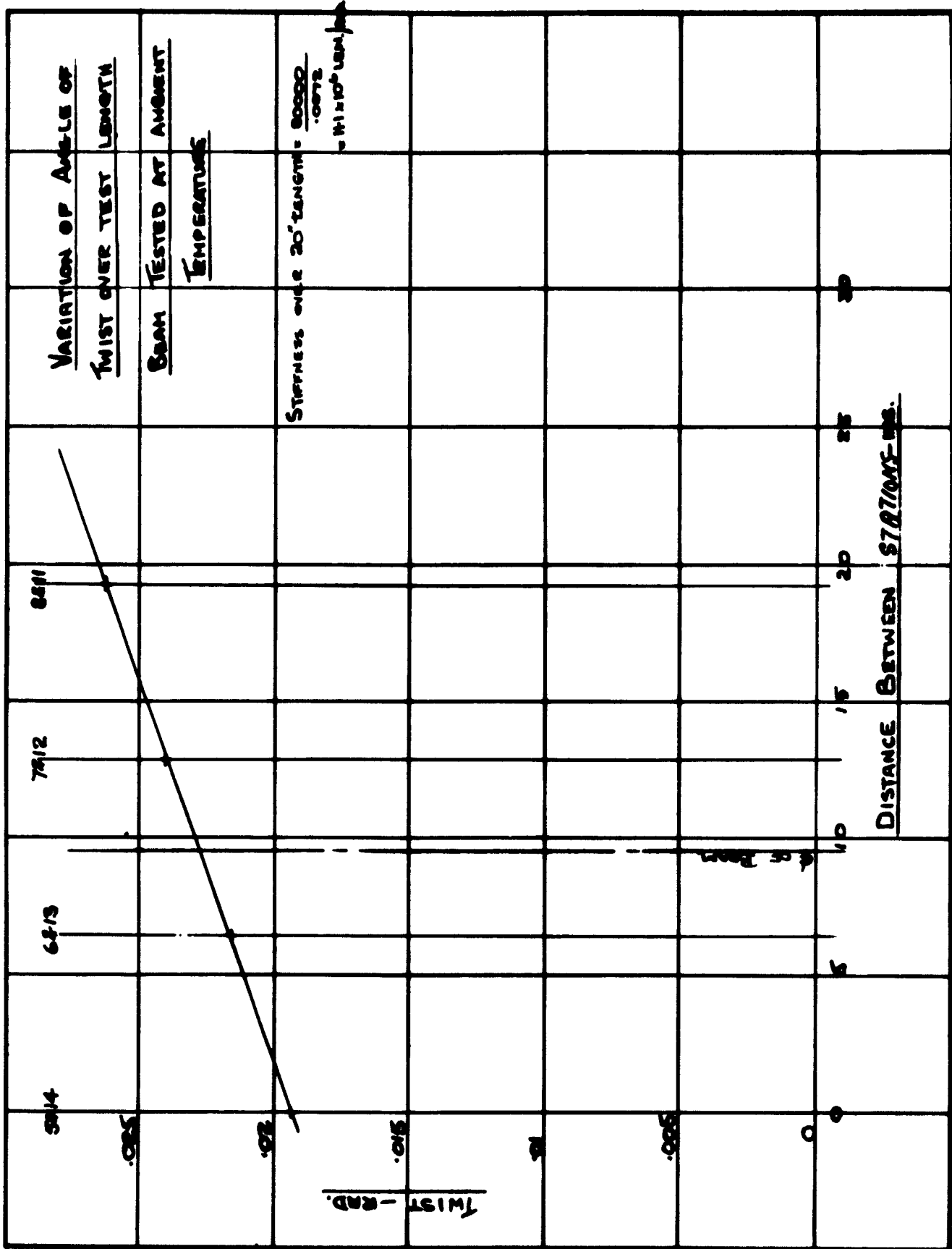

TORSION TEST ON BOX BEAMS (B.T.D. 166) SPEC. 1.

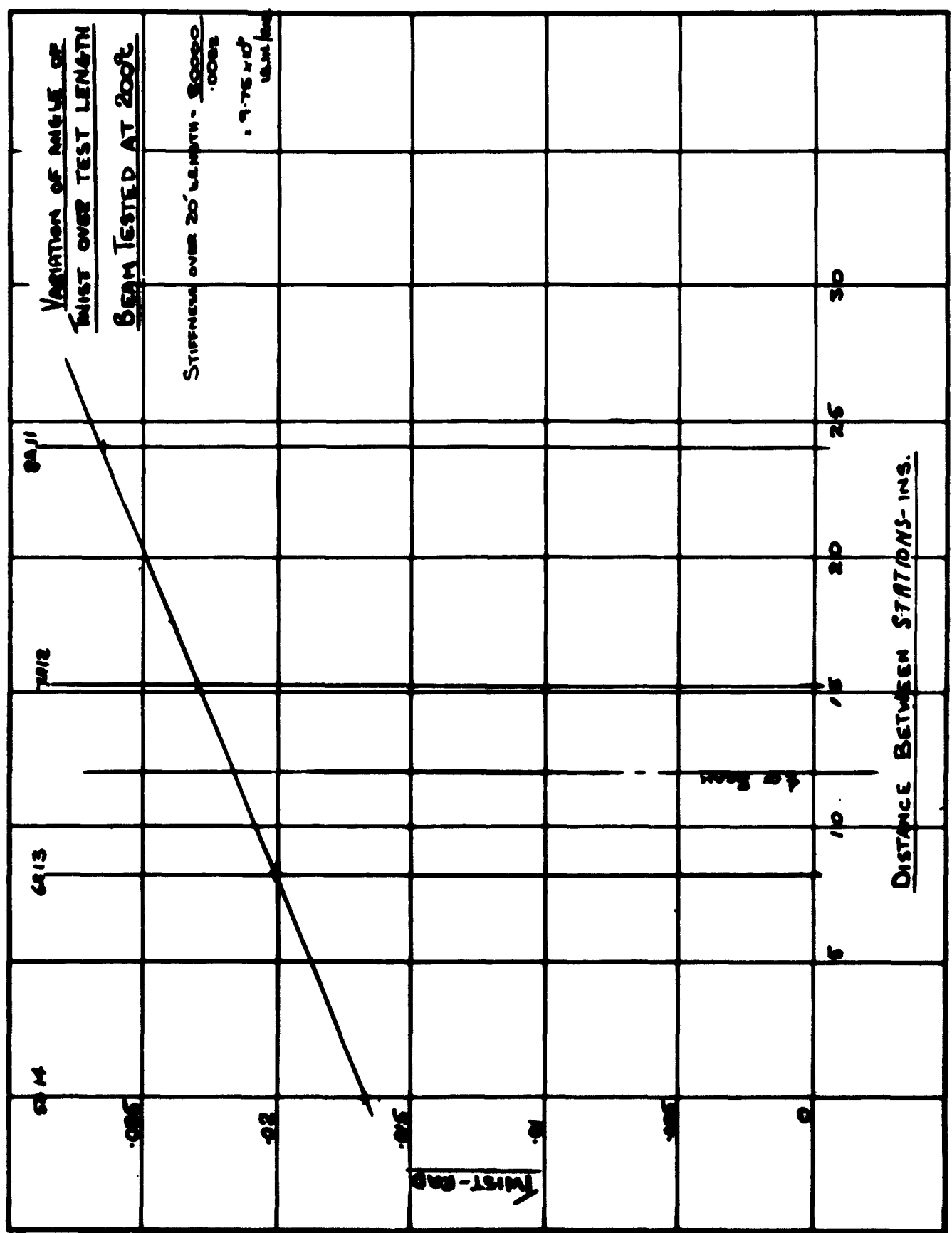

TORSION TEST ON BOX BEAM (A.T.D. 166) SPEC. 2

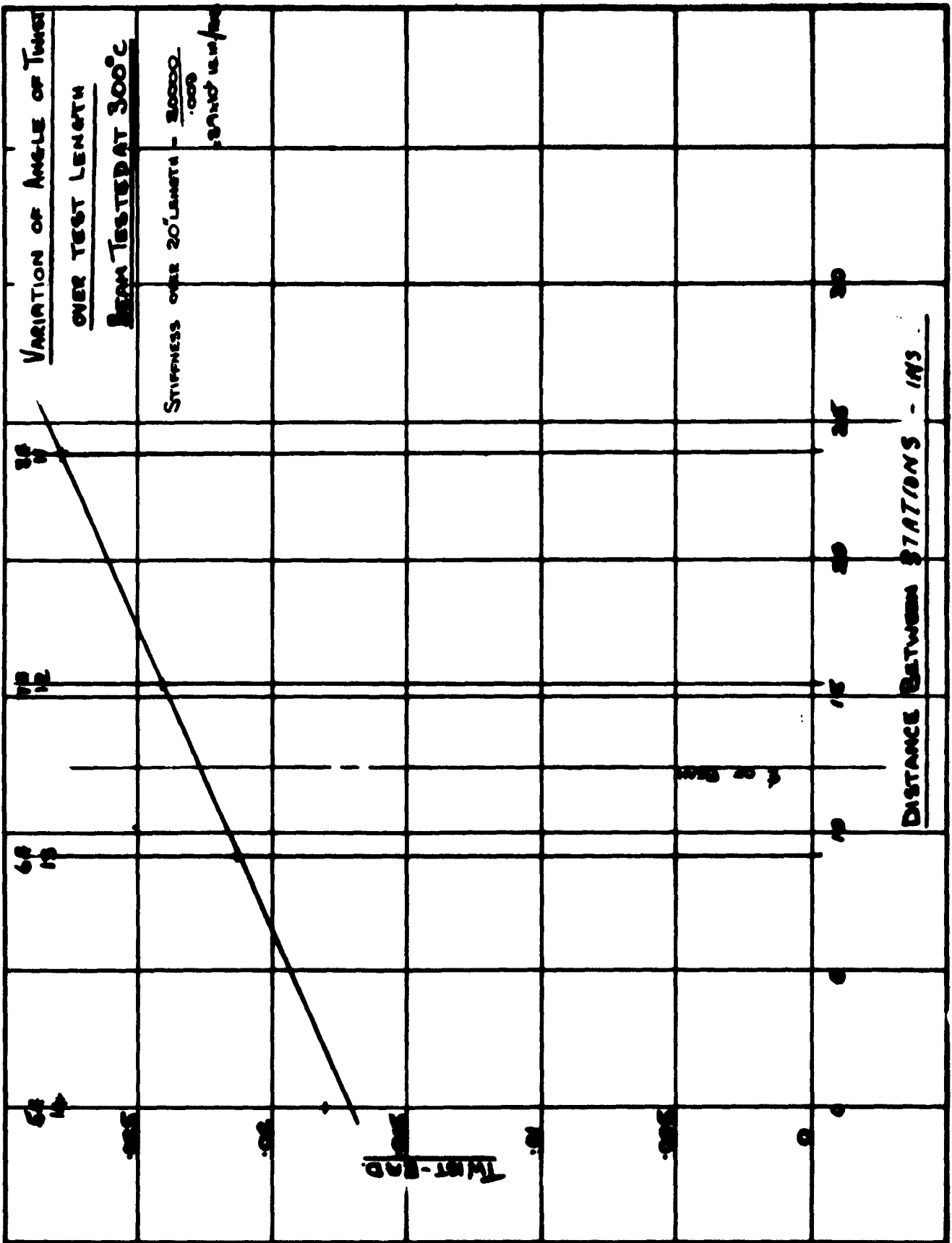

TORSION TEST ON BOX BEAMS (D.T.D. 166) SPEC. 3

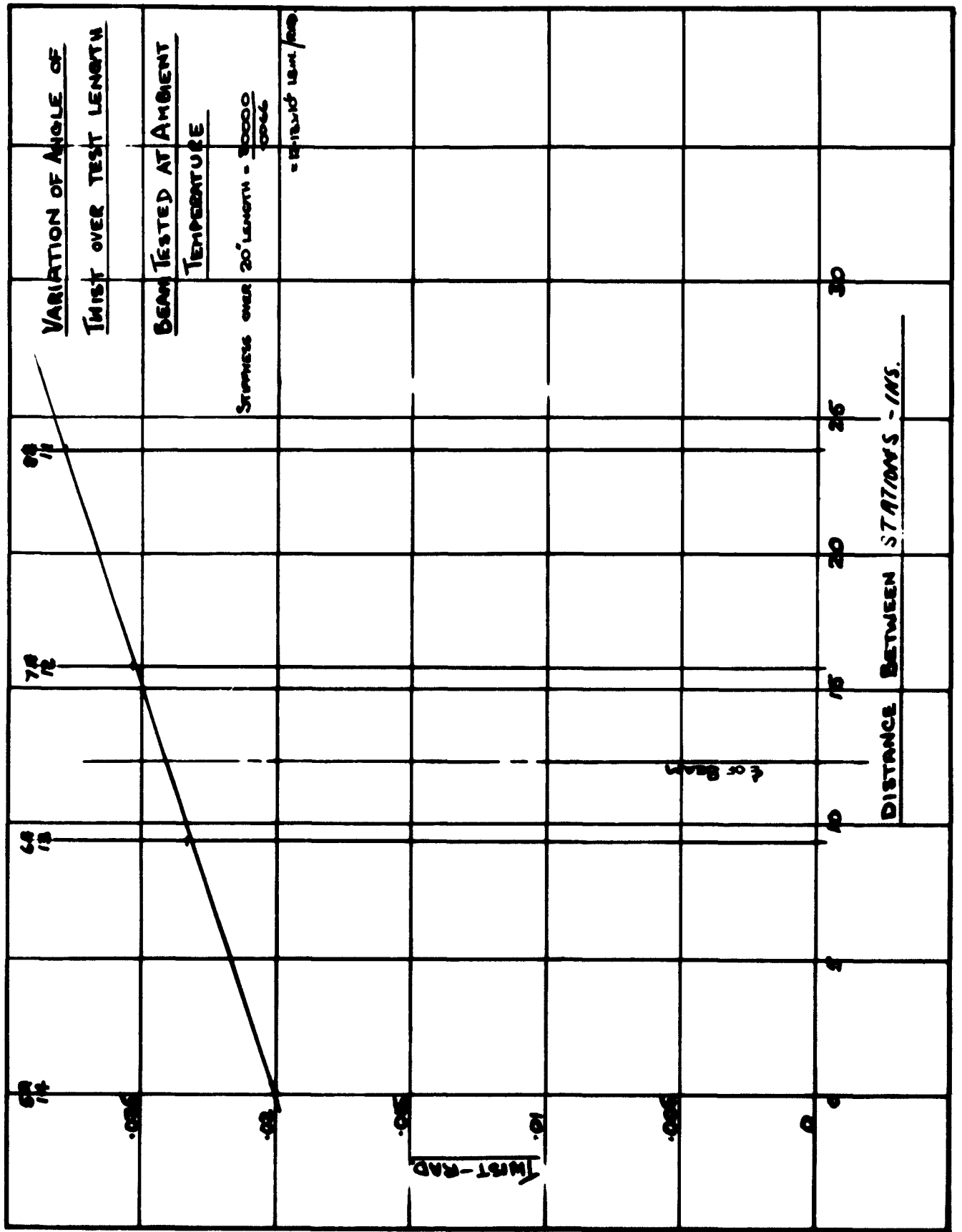

TORSION TEST ON BOX BEAMS (FIRTH VICKERS 820) SPEC. 4

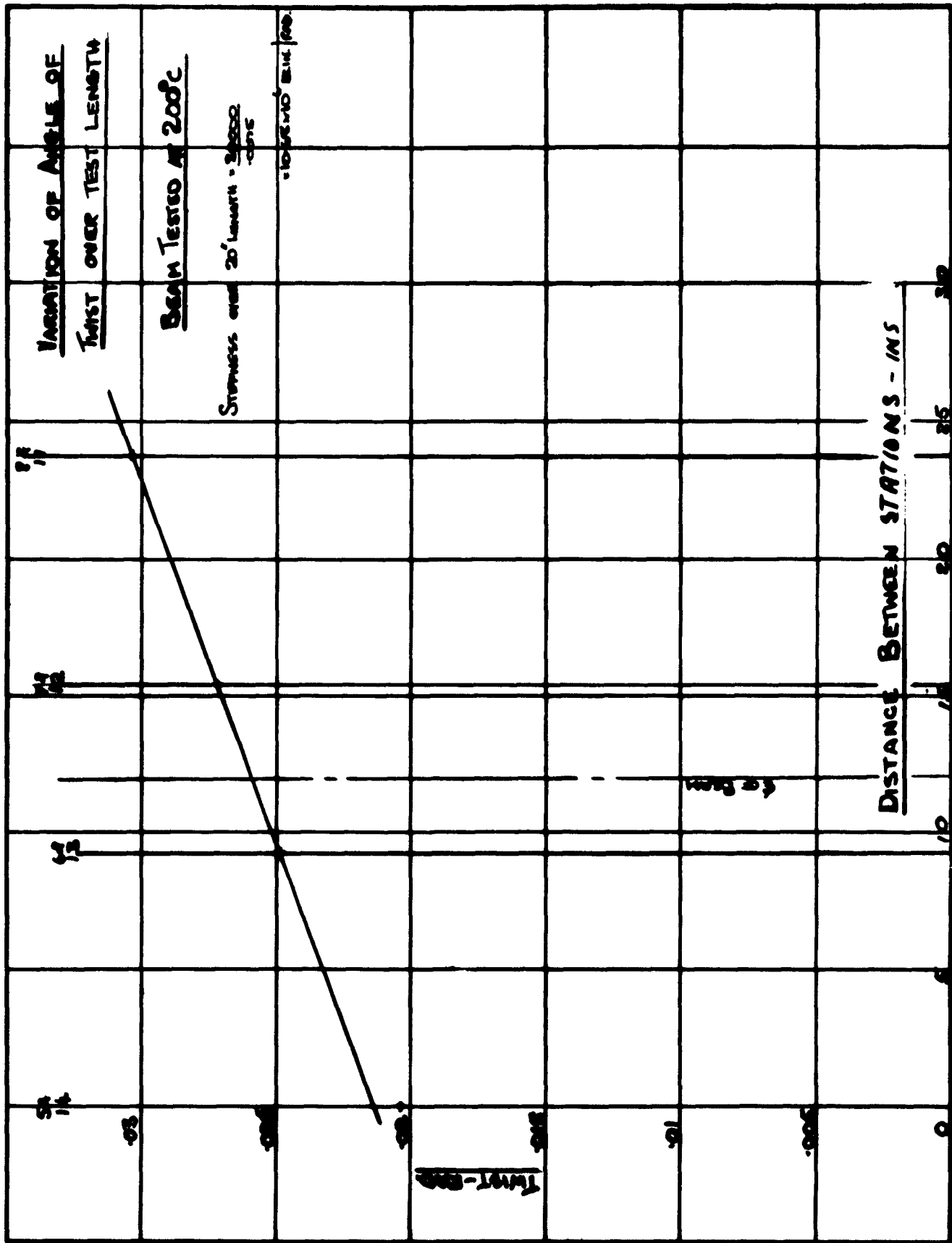

TORSION TEST ON BOX BEAMS (FIRTH VICKERS 520) SPEC. 5

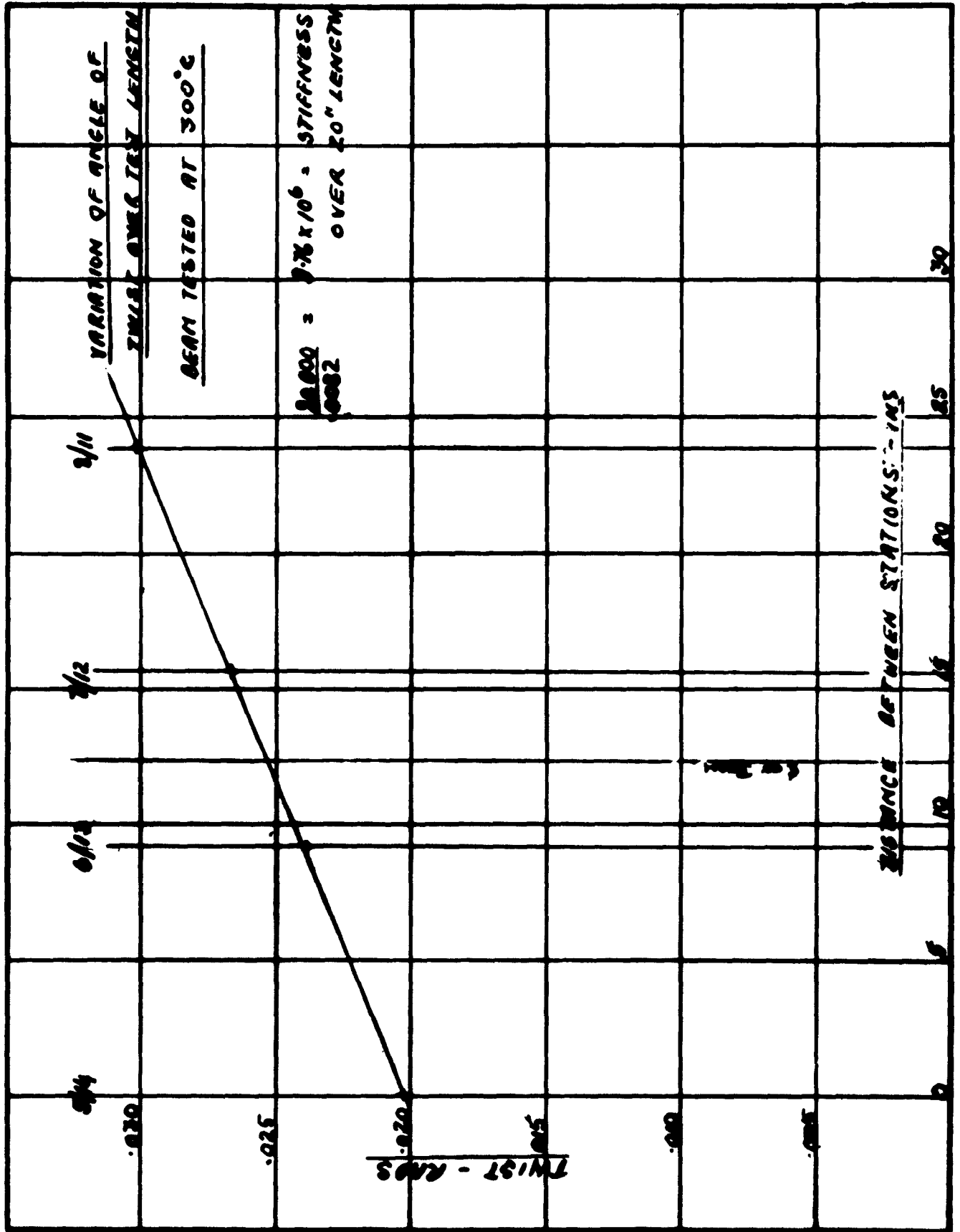

TORSION TEST ON BOX BEAMS (PART 1) (PICKER 520) SPEC N° 6

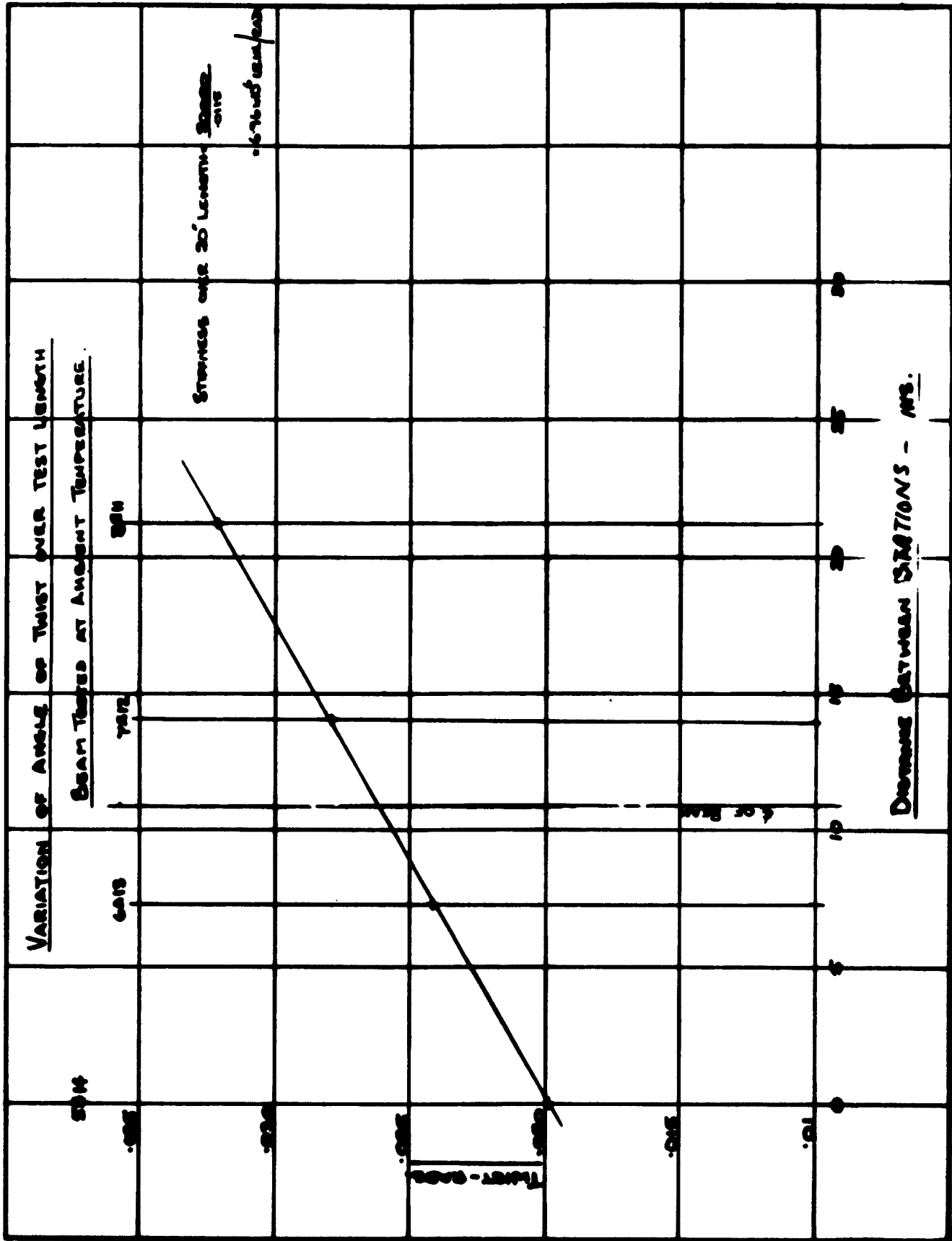

TORSION TEST ON BOX BEAMS (I.C.I. 37) SPEC. NO. 7.

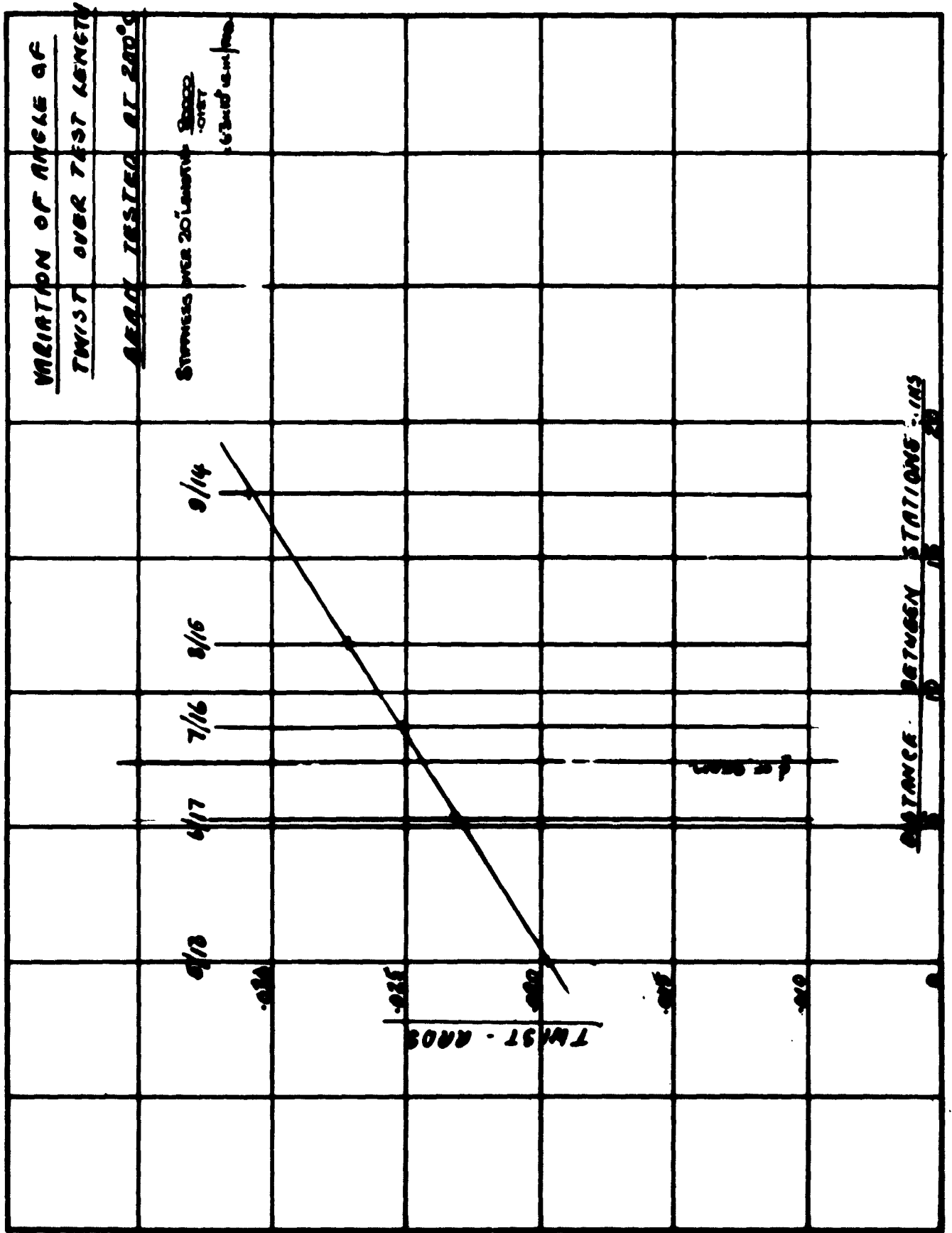

TORSION TEST ON BAR GRAMS (12,327) SPEC N° 2

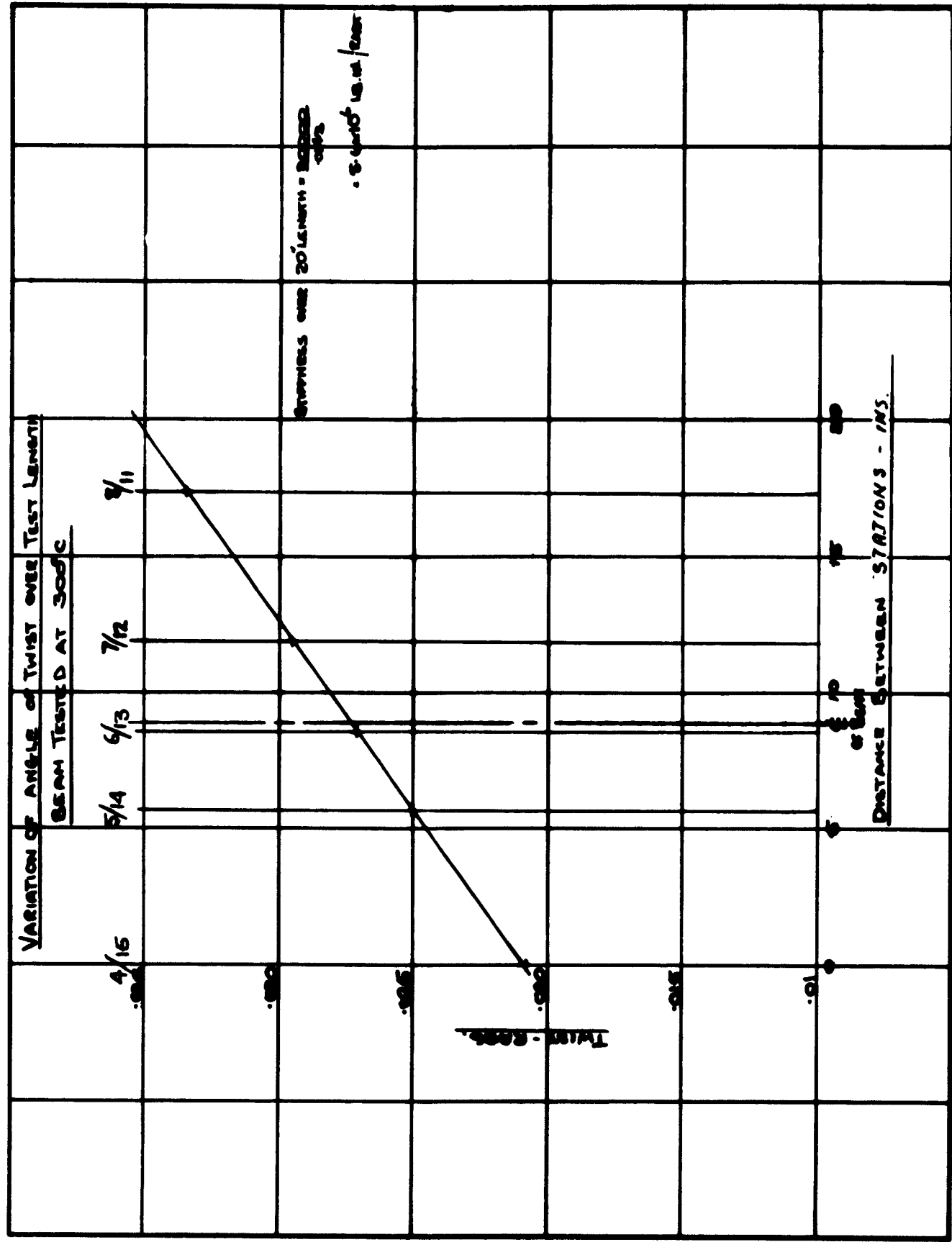

TORSION TEST ON BOX BEAMS (I.C.I. 317) SPEC. No. 9.

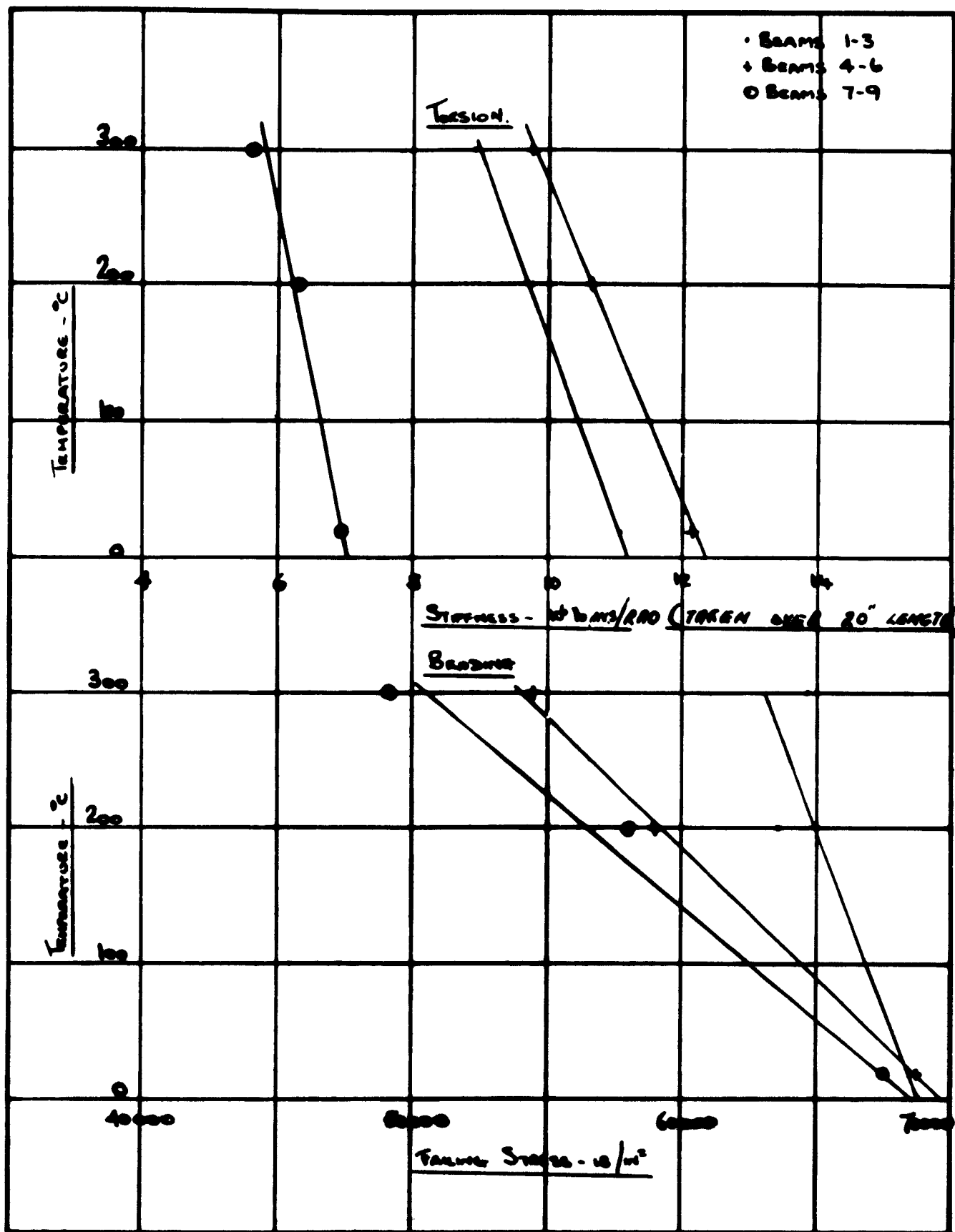

VARIAION OF BEAM STRENGTH WITH TEMPERATURE

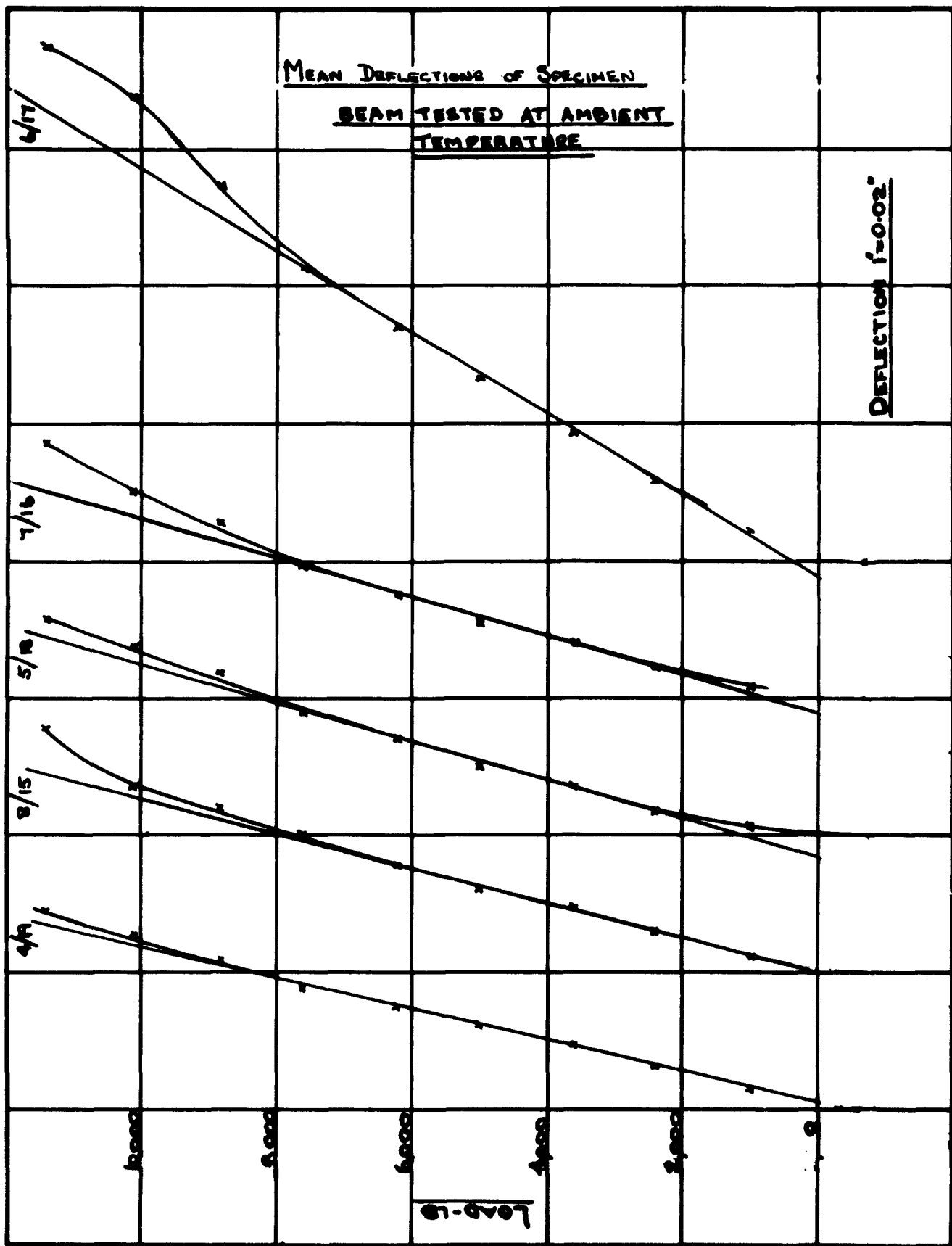

BENDING TEST ON BOX BEAMS (D.T.D. 146) SPEC. No. 1.

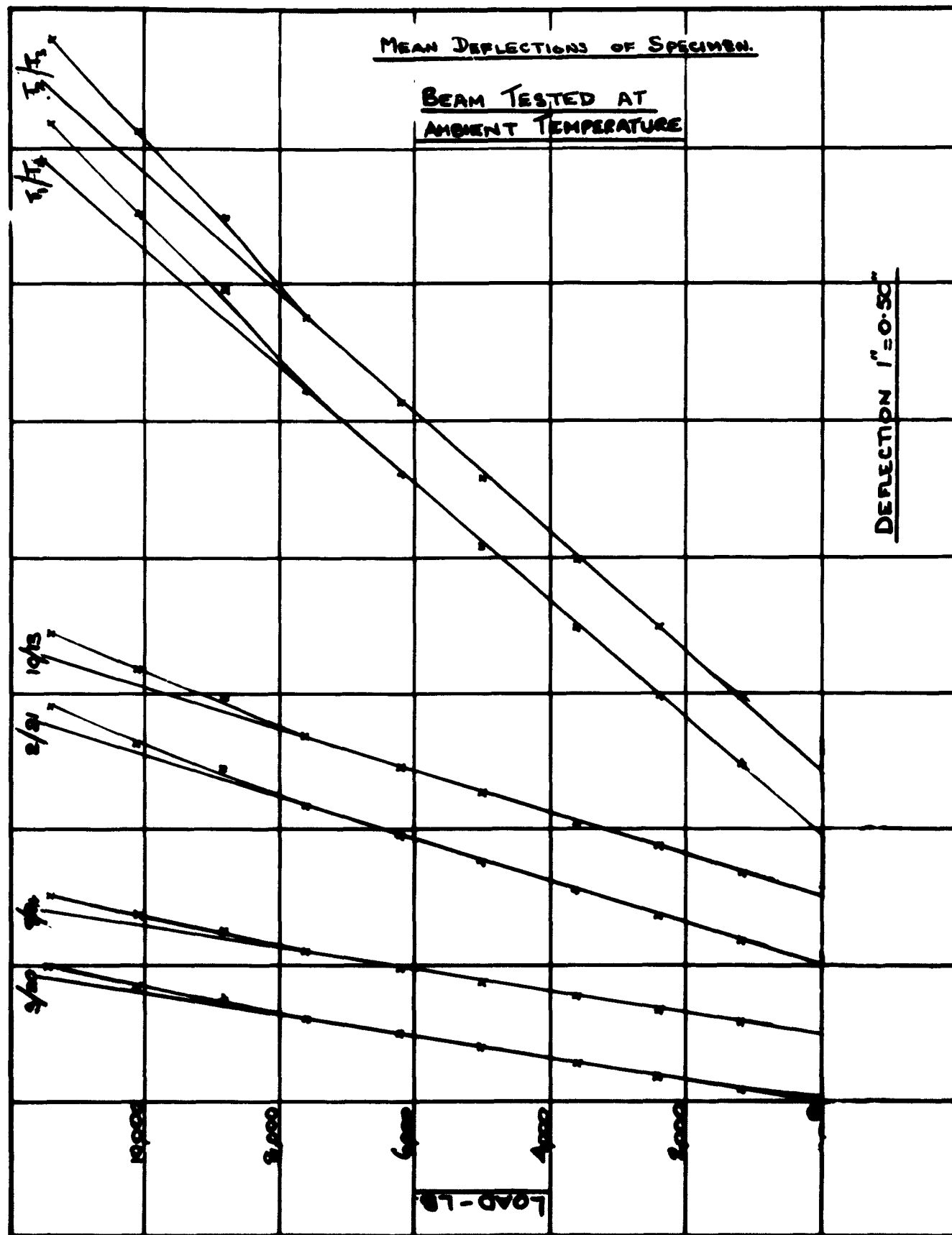

BENDING TEST ON BOX BEAMS (D.T.D 166) SPEC. No. 1

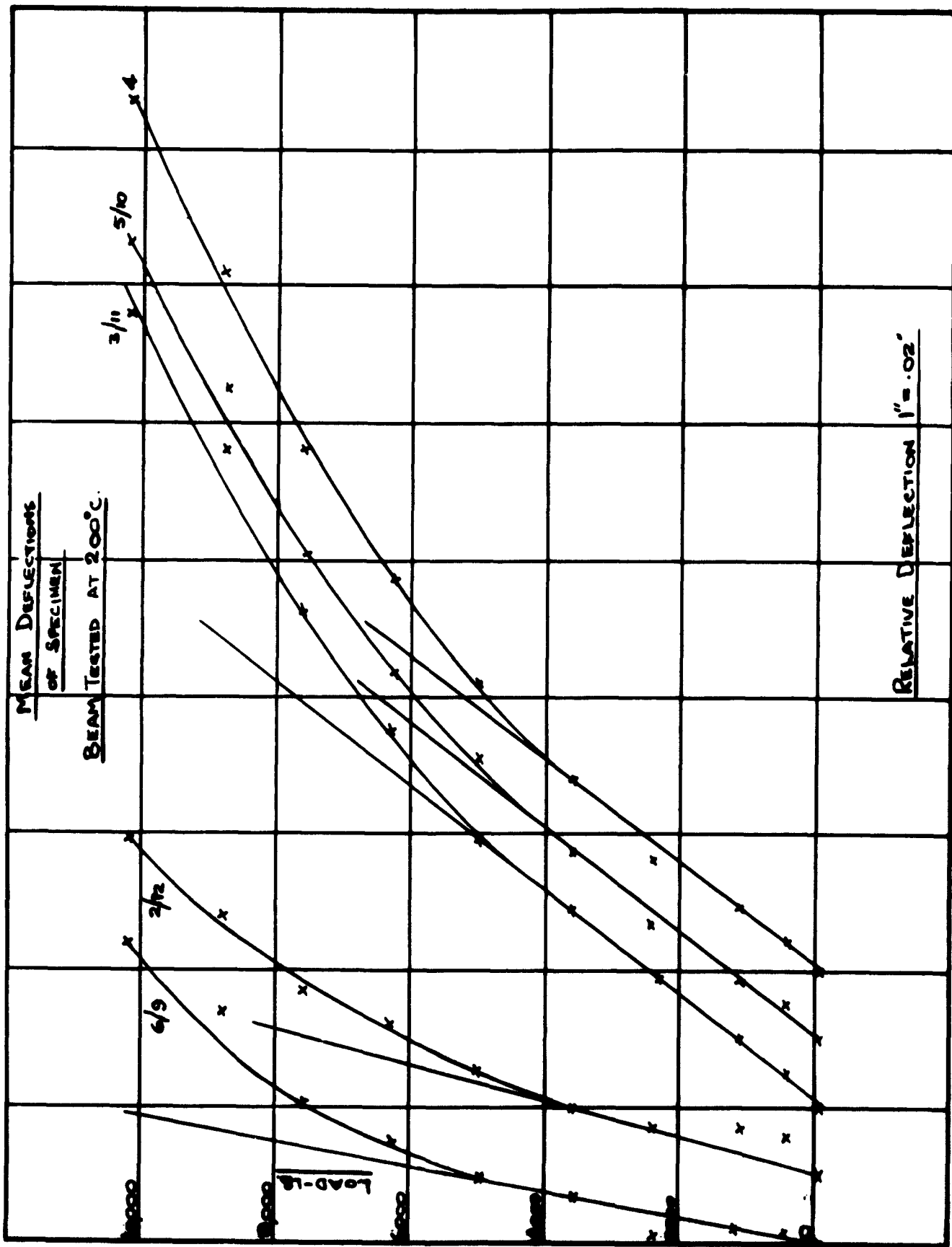

BENDING TEST ON BOX BEAMS (D.T.O. 166) SPEC. NO. 2

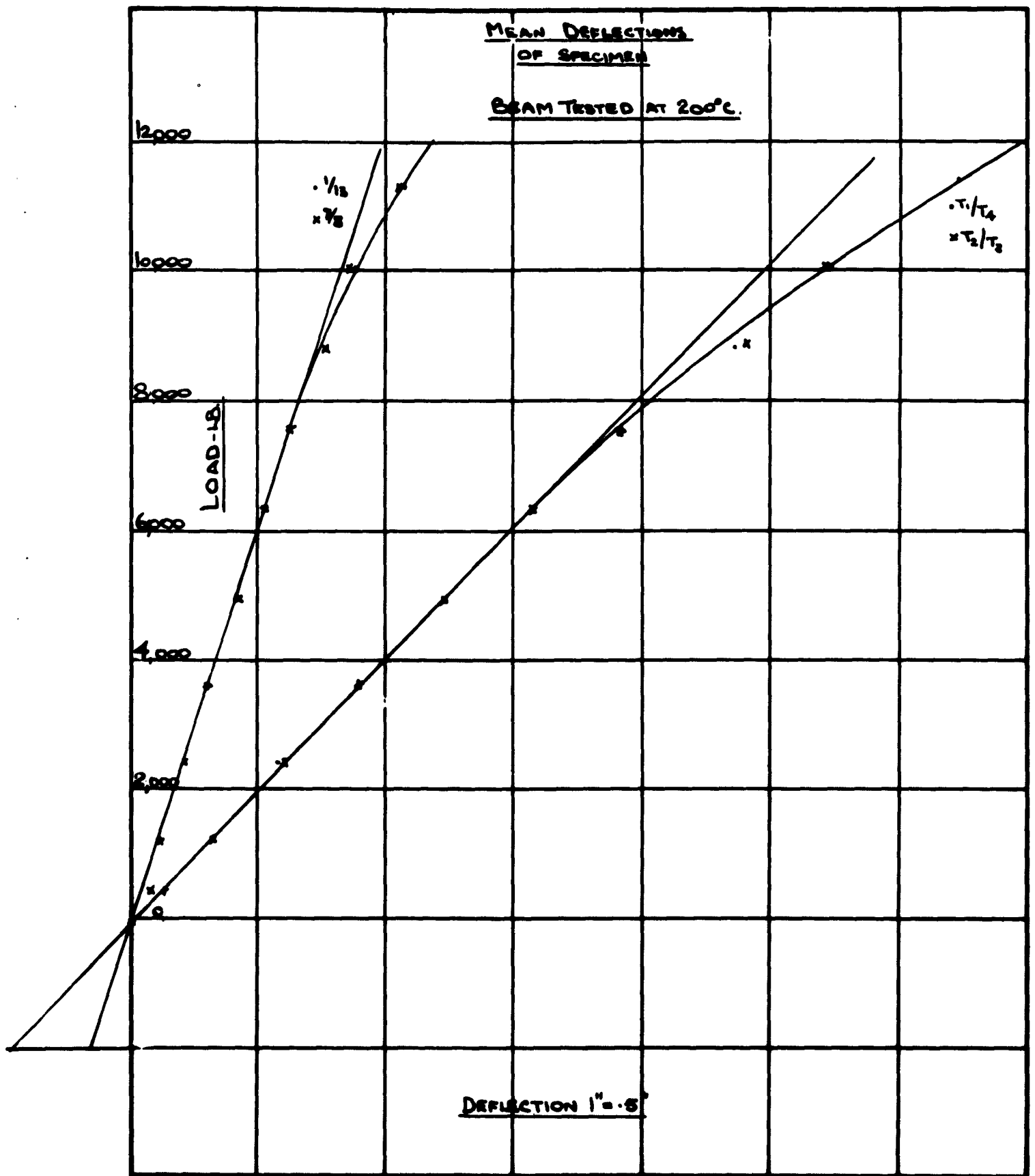

BENDING TEST ON BOX BEAMS (Q.T.D 166) SPEC. NO. 2.

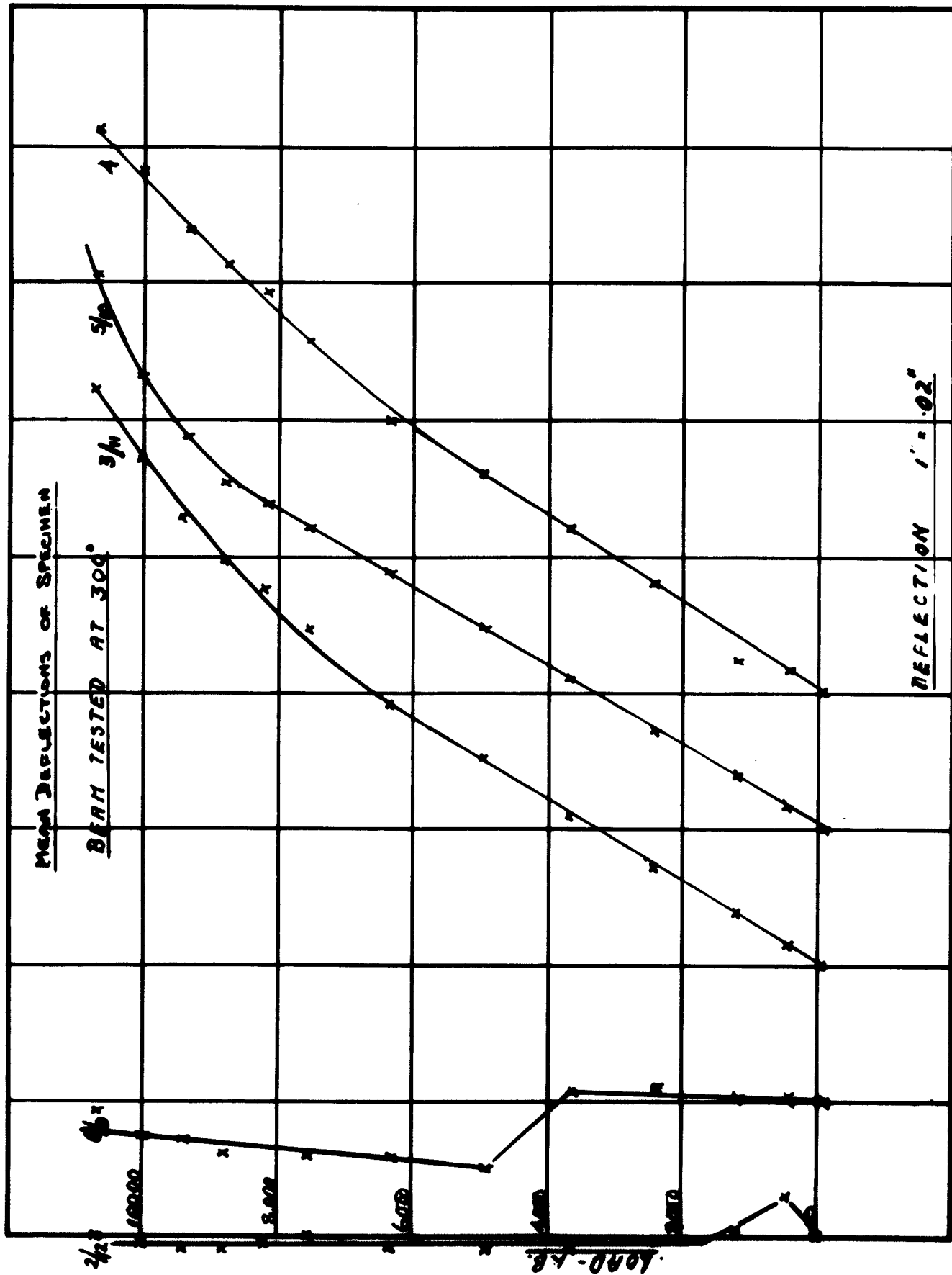

BENDING TEST ON BOX BEAM (DT0166) SPEC N° 3

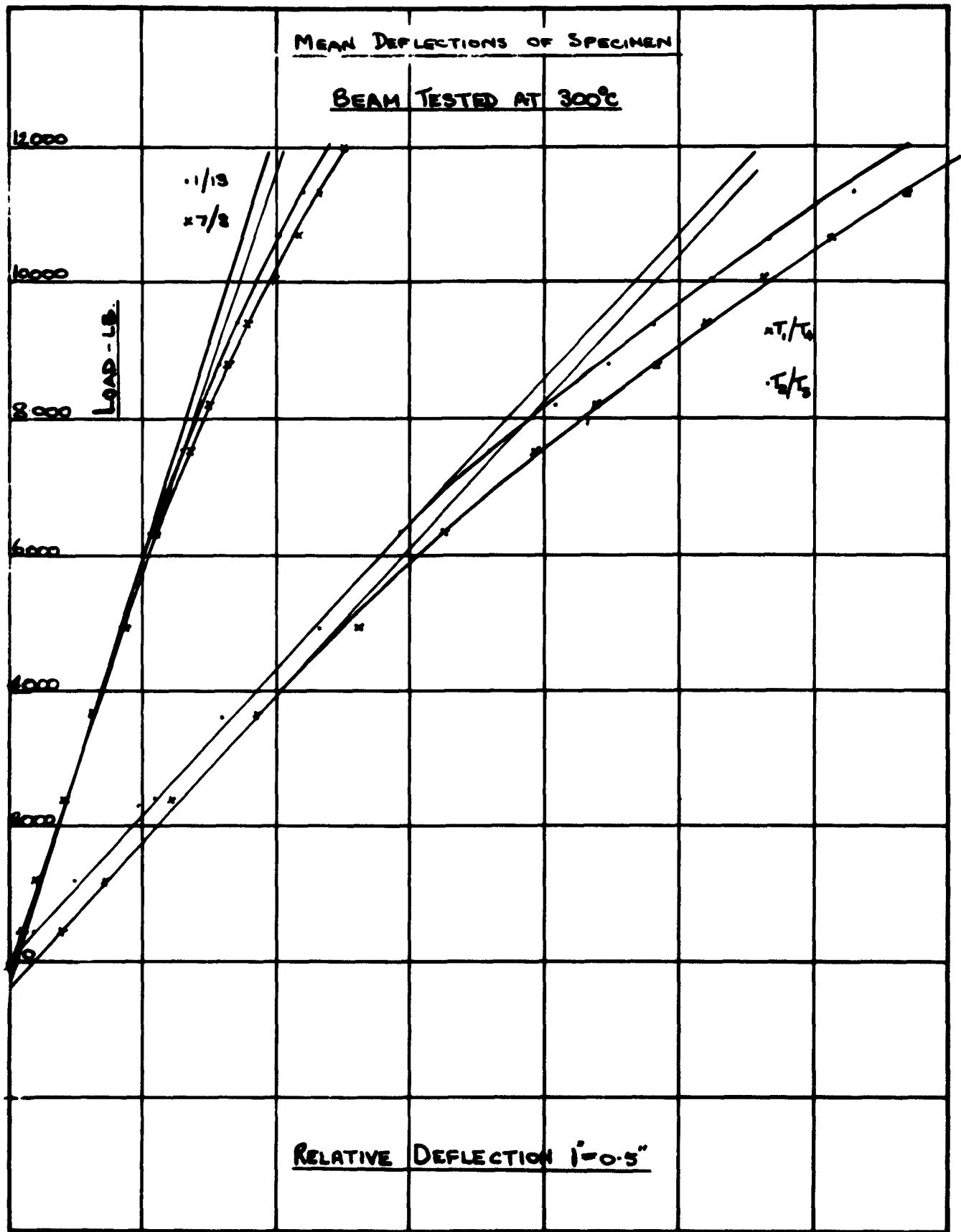

BENDING TEST ON BOX BEAMS (B.T.D. 166) SPEC. No. 3

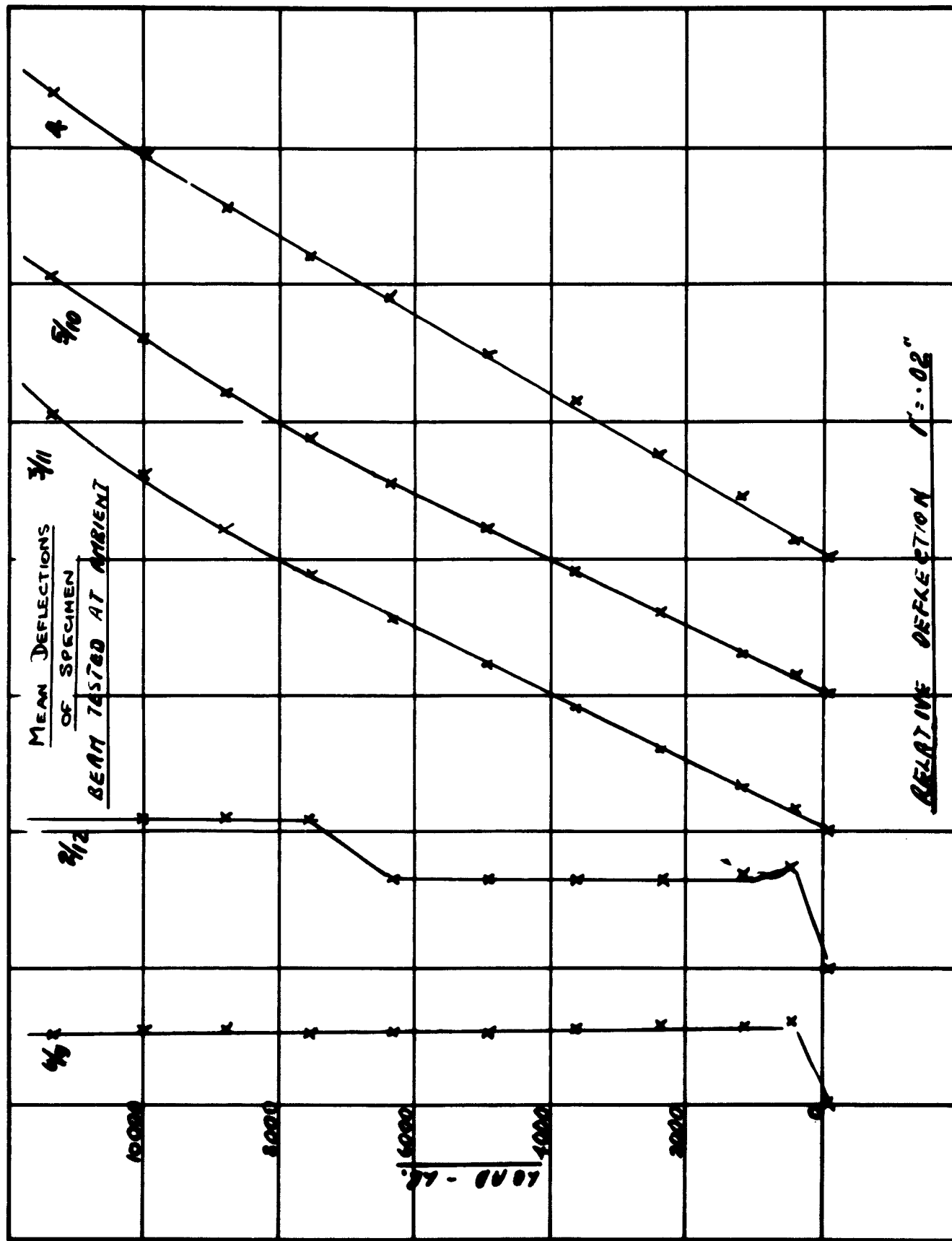

BENDING TEST ON BOX BEAM (ARTY VICORS 520) SPEC N° 4. FIG. 40

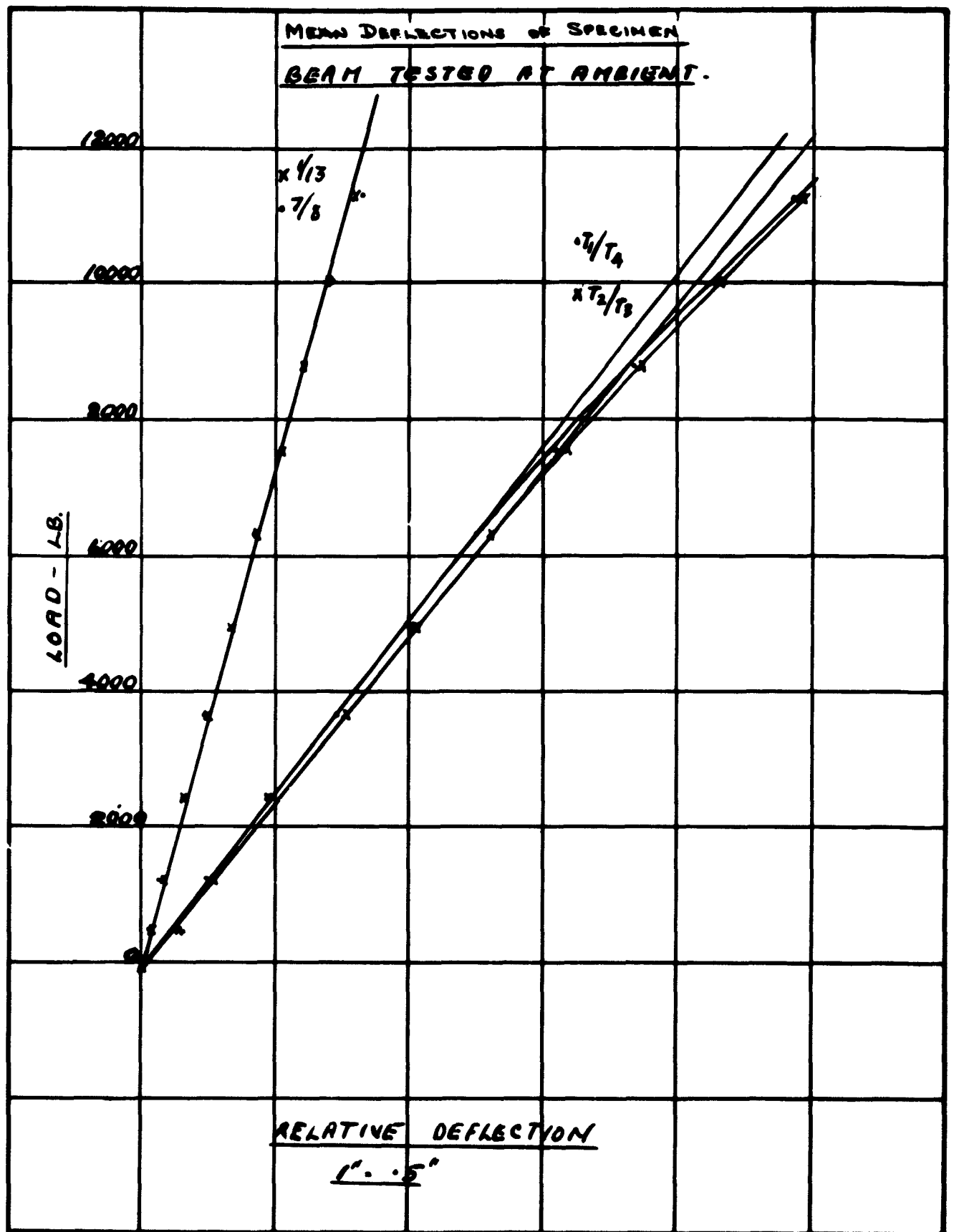

BENDING TEST ON BOX BEAM (ARTH VICKERS 520) SPEC N° 4.

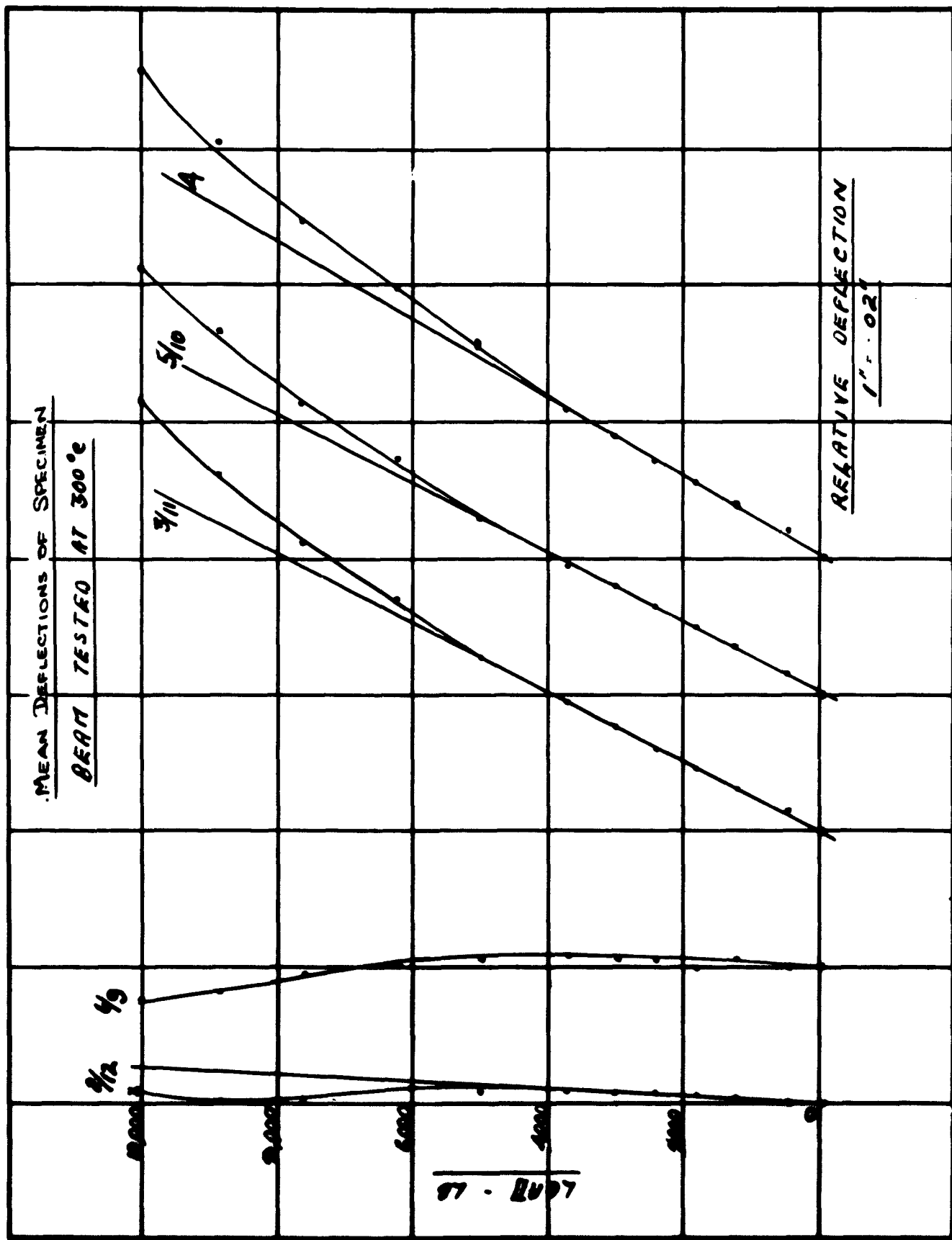

BENDING TEST ON BOX BEAMS (F.V. 520) SPEC. No. 5.

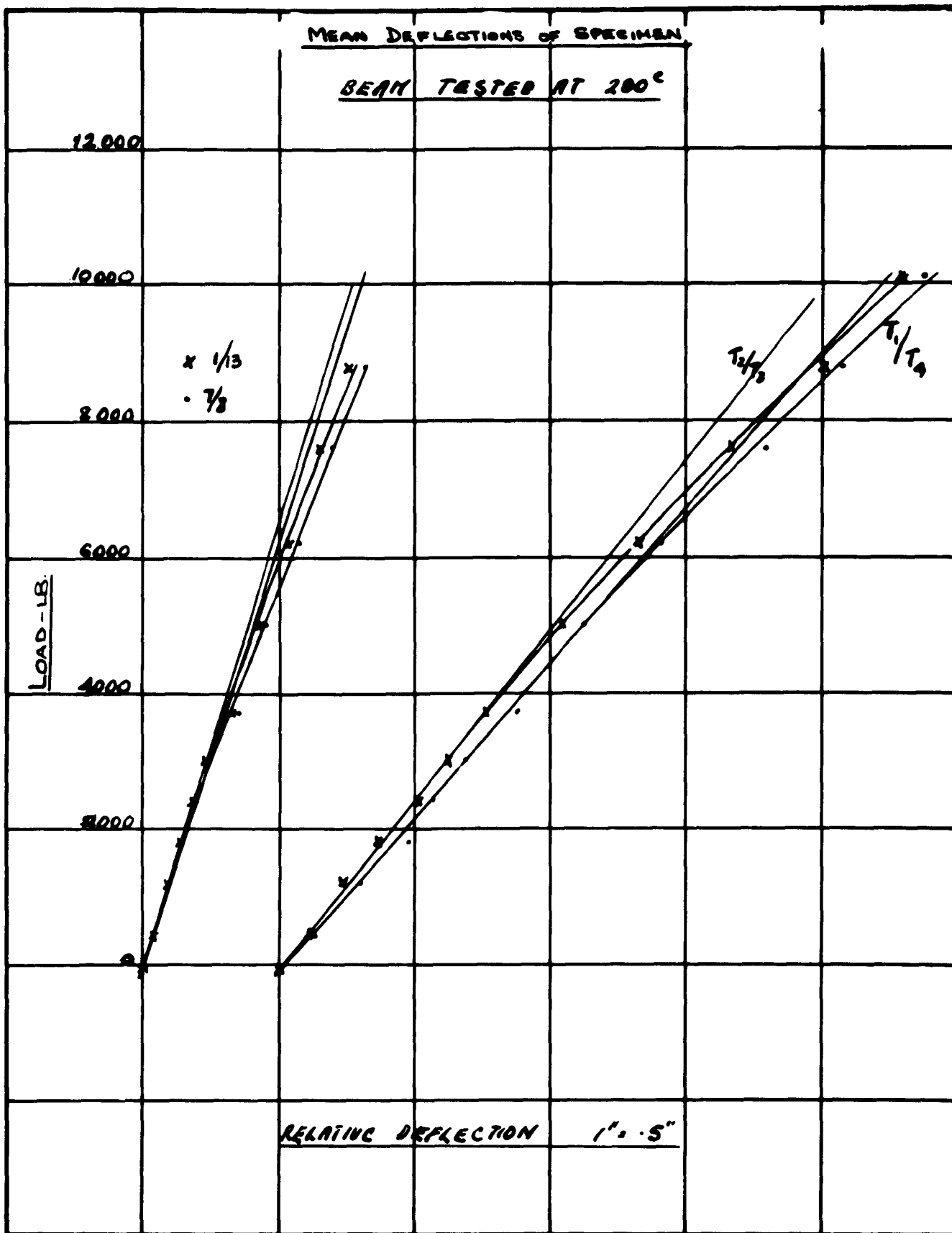

BENDING TEST ON BOX-BEAMS (FIRTH VICKERS 520) SPEC N° 5

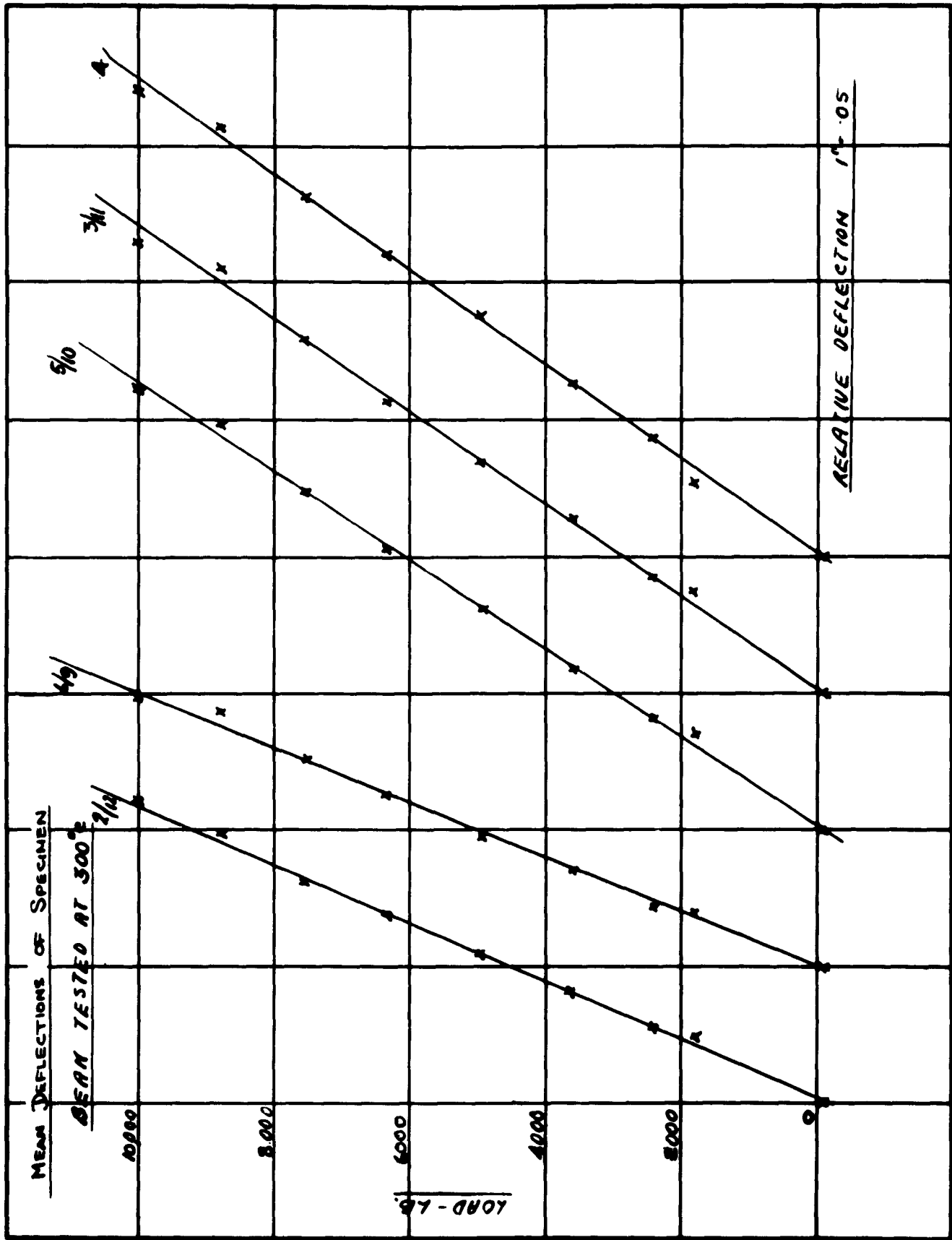

BENDING TEST ON BOX BEAMS (FIRTH VICKERS 520) SPEC NO 6

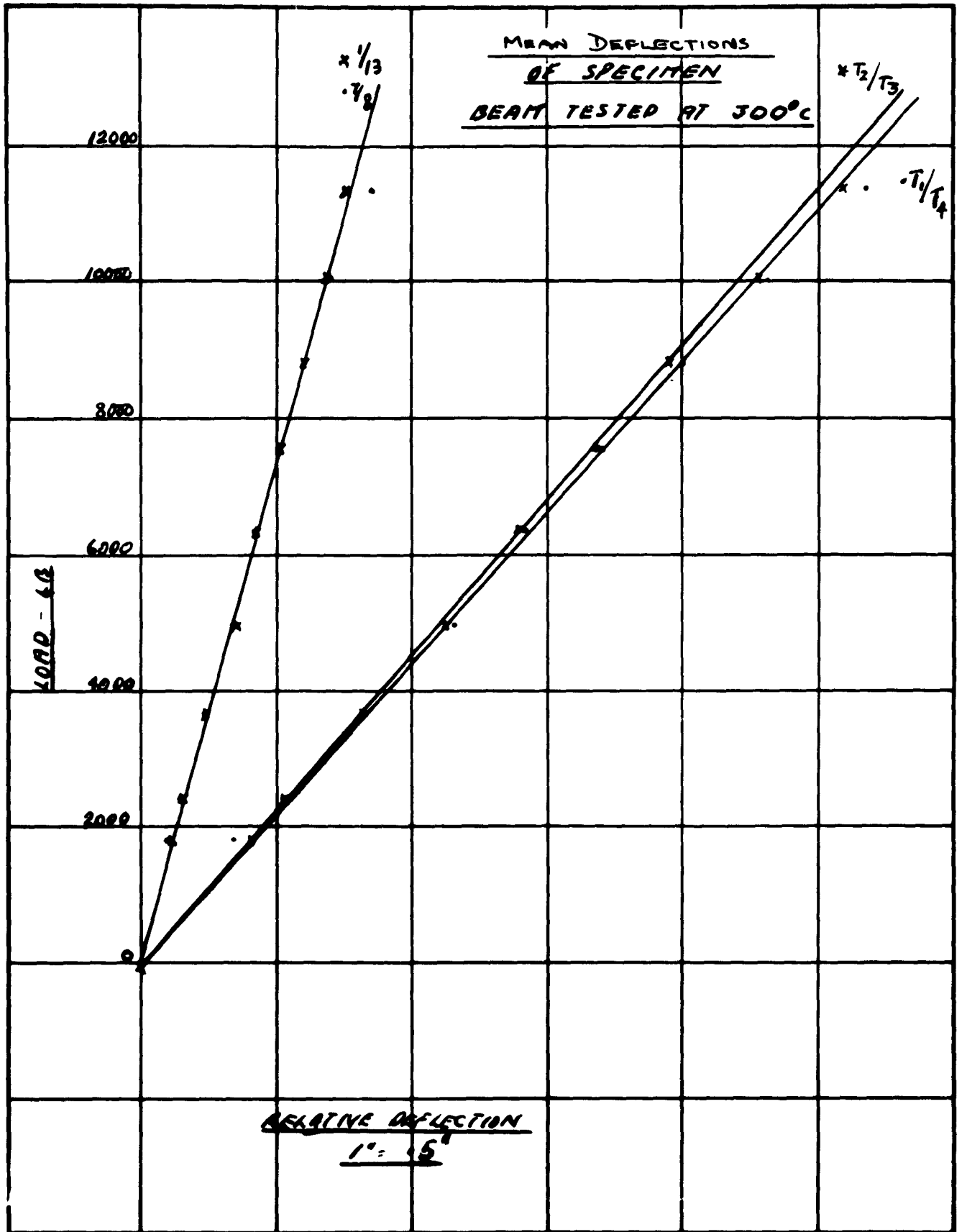

BENDING TEST ON BOX BEAMS (FRAN VICKERS 520) SPEC N° 6

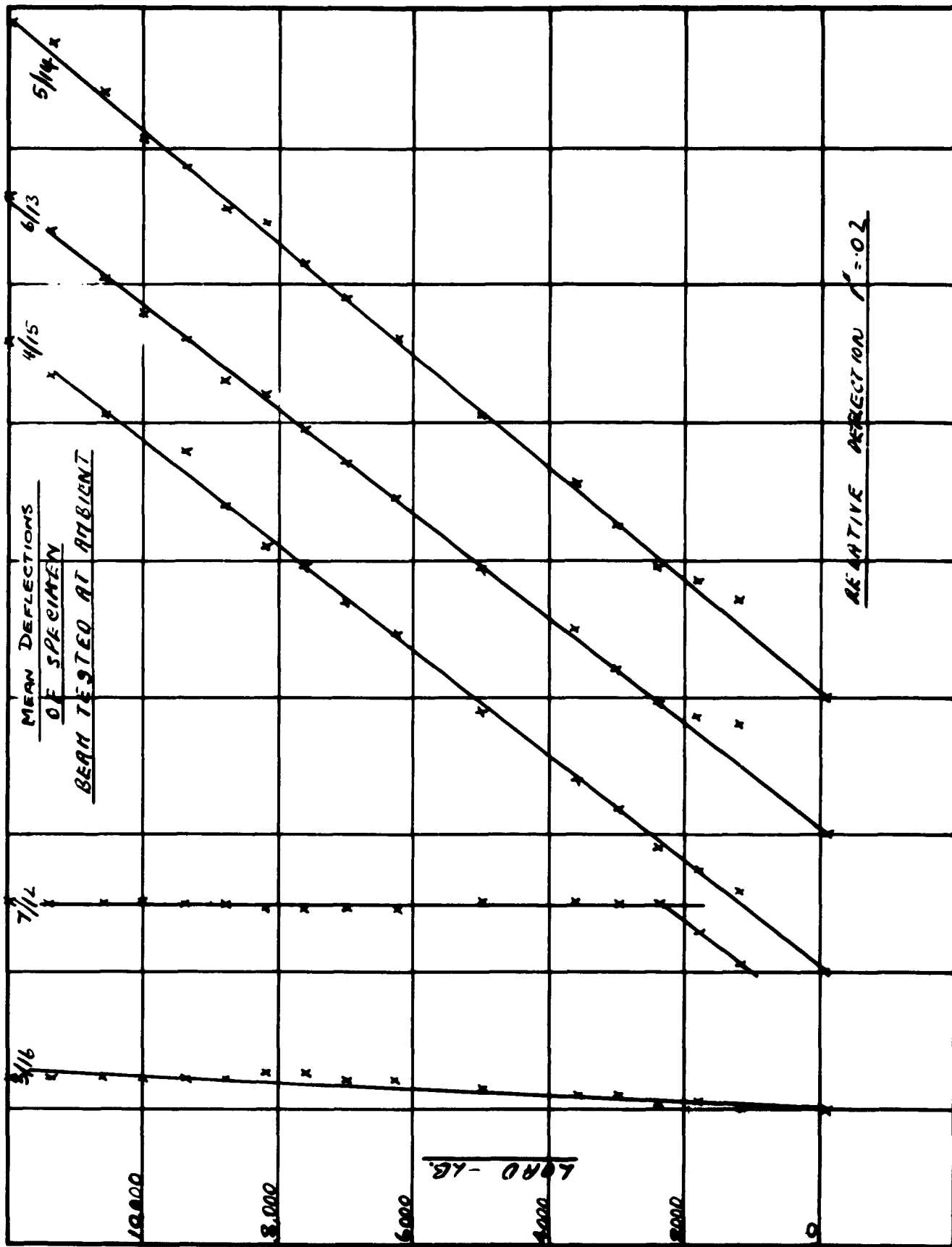

BENDING TEST ON BOX BEAMS (ICI 217) SPEC NO 7

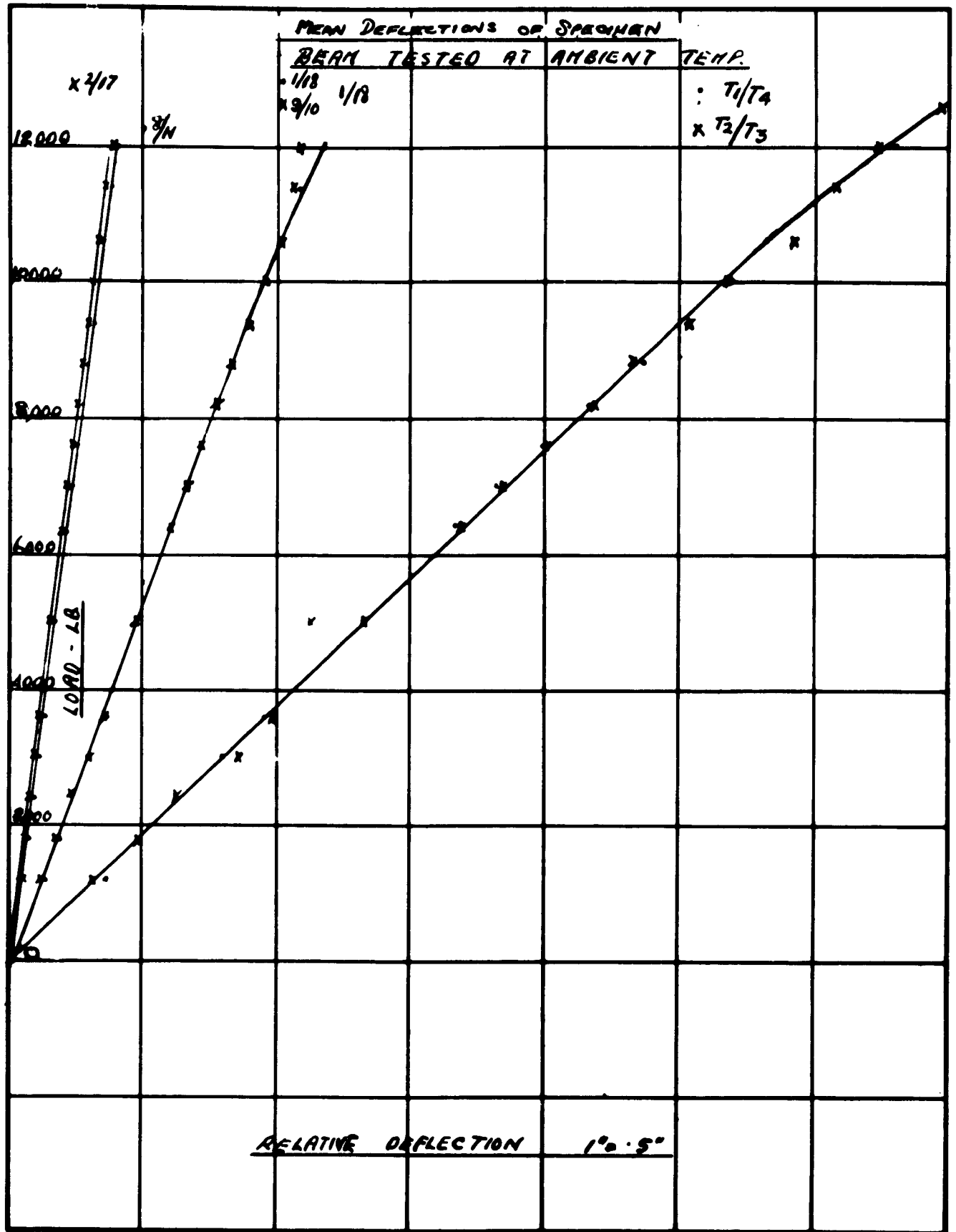

BENDING TESTS ON BOX BEAM (1U 317) SPEC 7

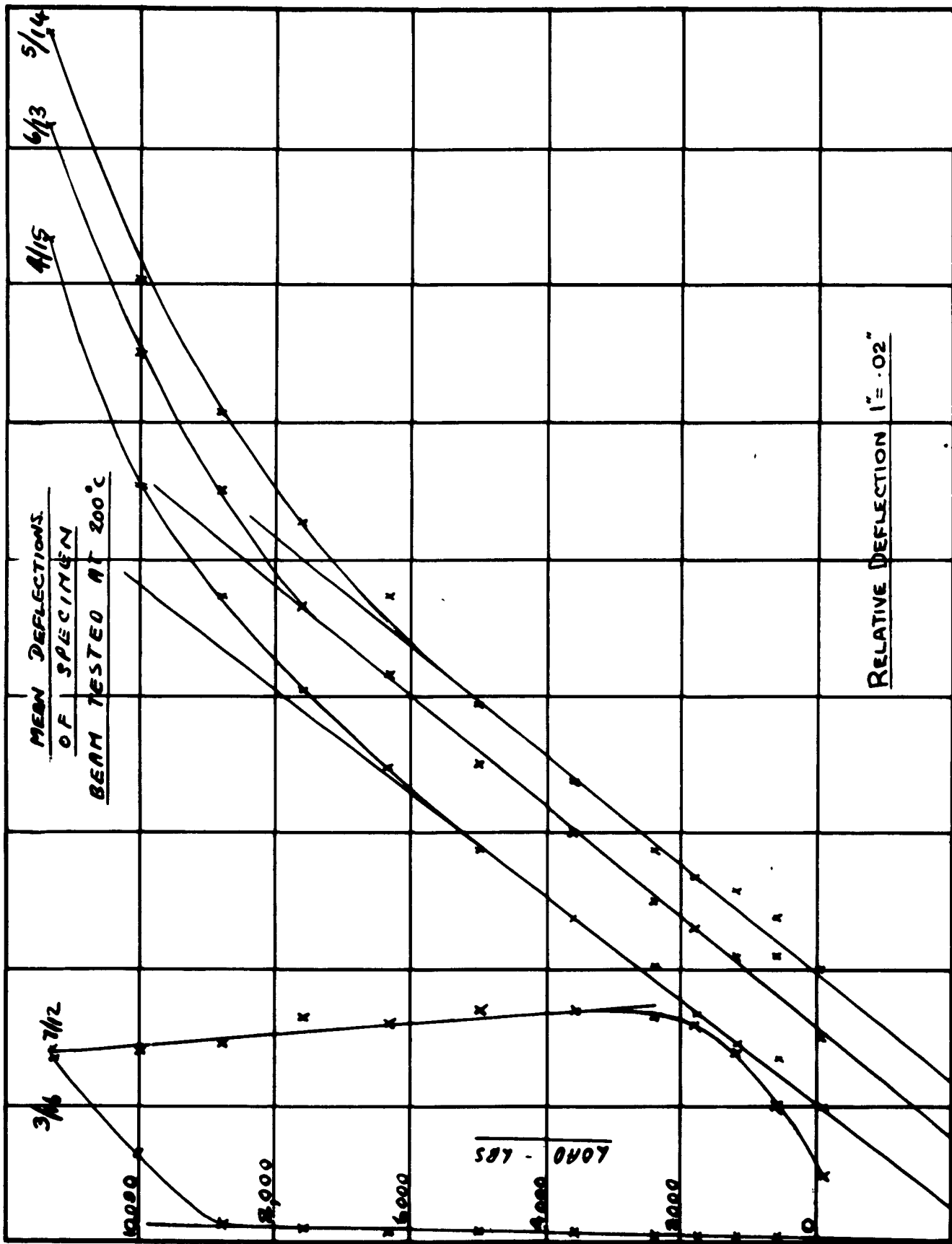

BENDING TEST ON BOX BEAMS (IC1317) SPEC N° 8

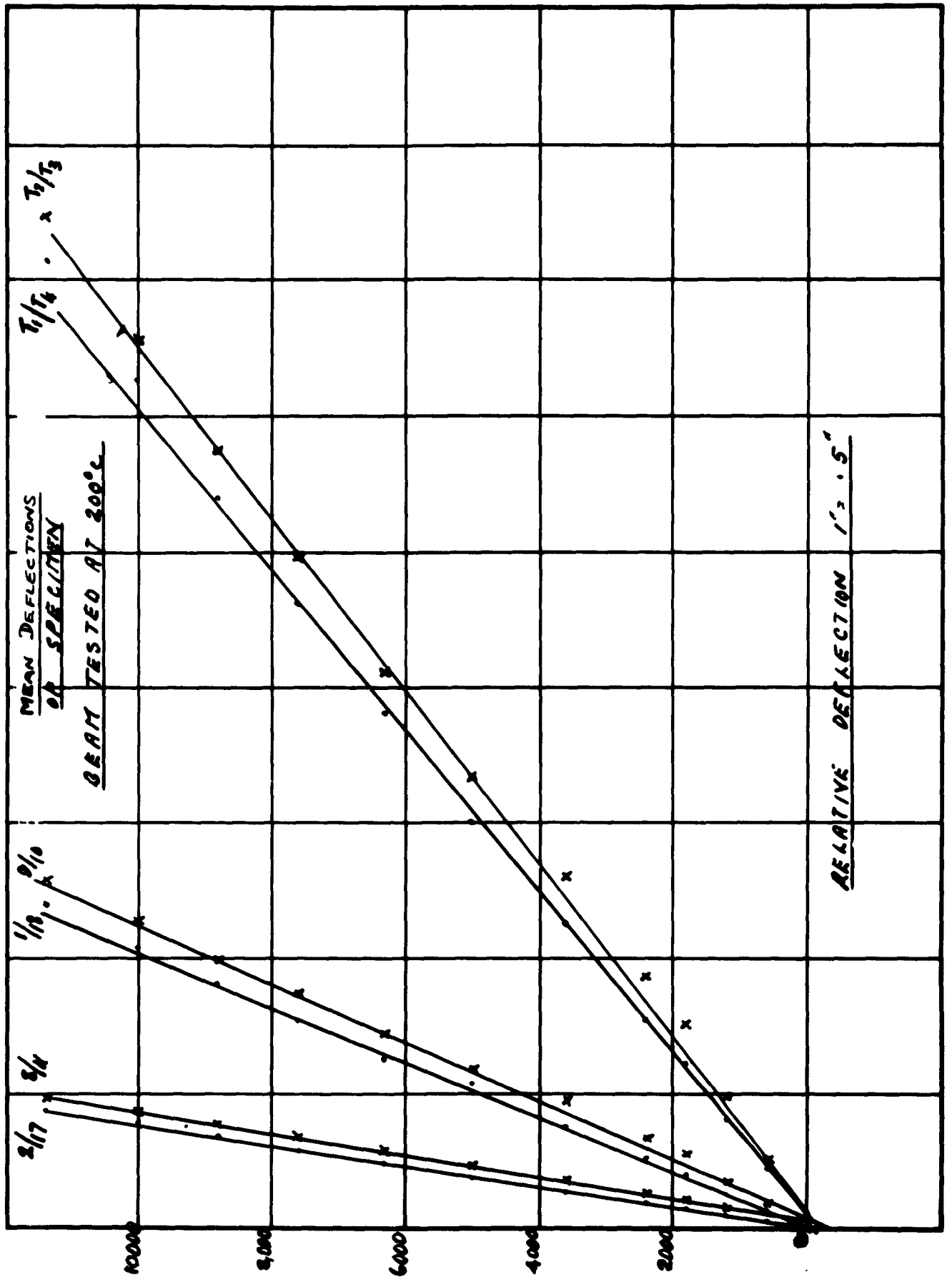

BENDING TEST ON BOX BEAMS (ICI 317) SPEC N° 8

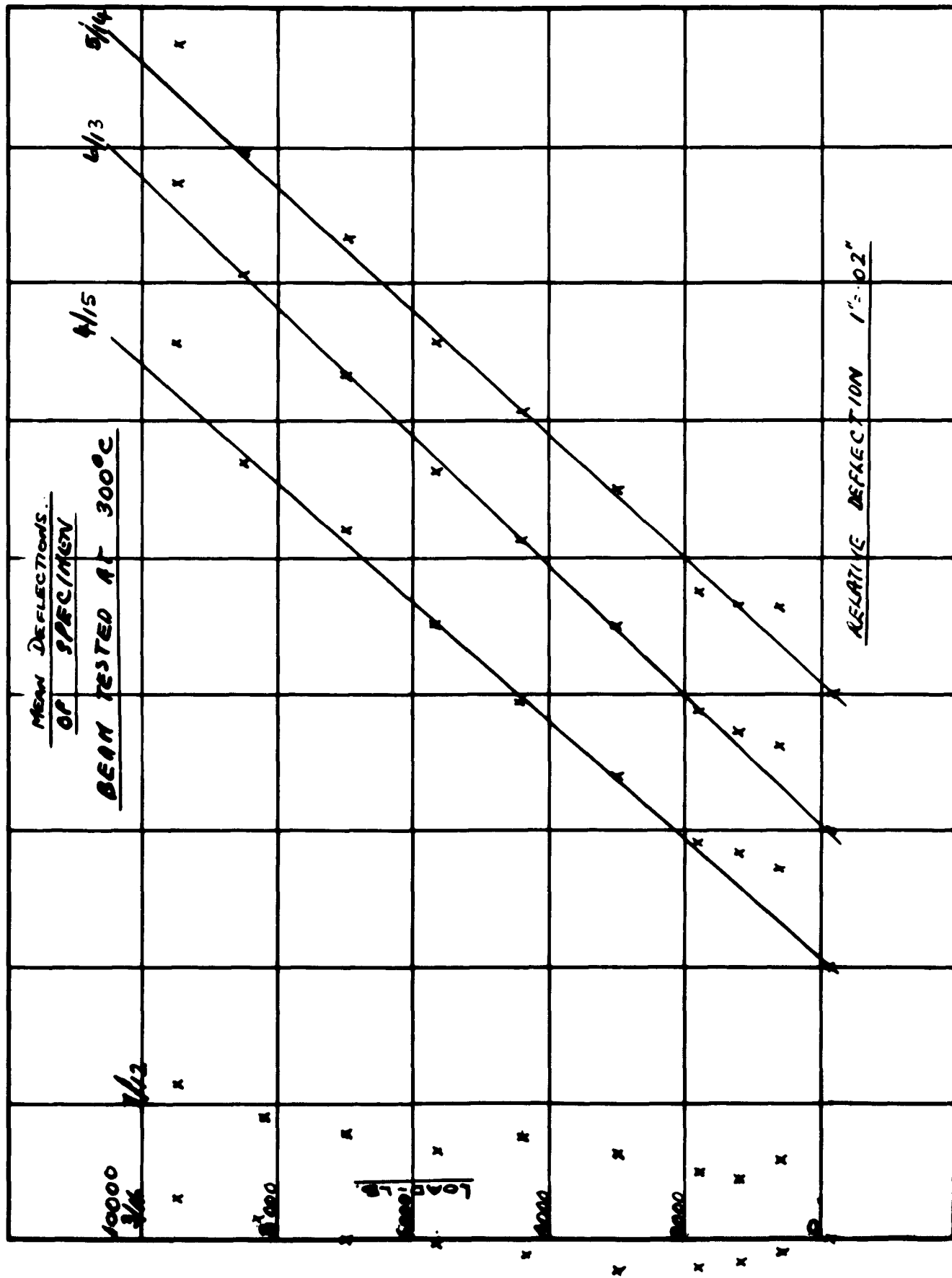

BENDING TEST ON BOX BEAMS (ICI 317) SPEC 9. FIG. 50

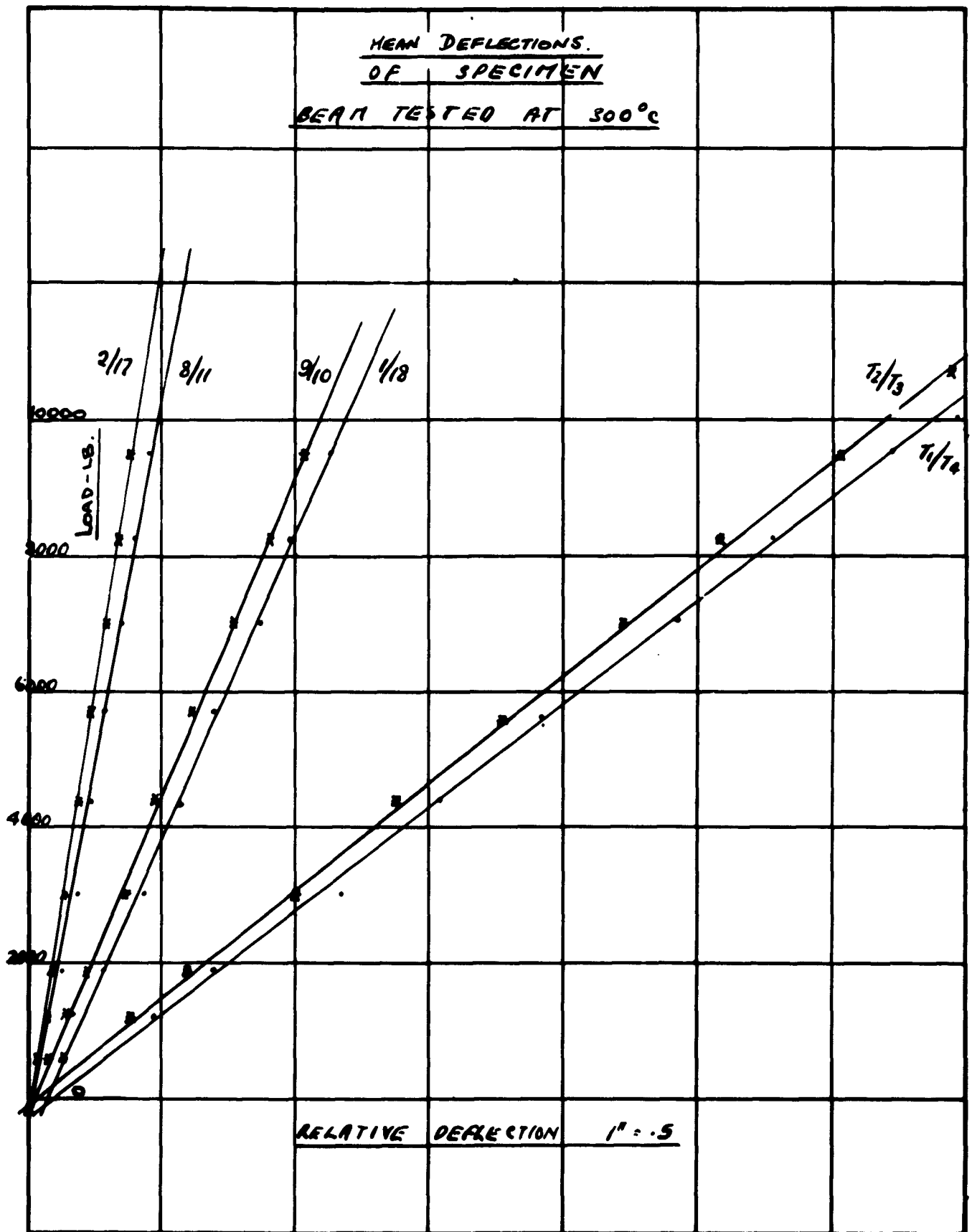

BENDING TEST ON BOX BEAMS (ICI 317) SPEC 9

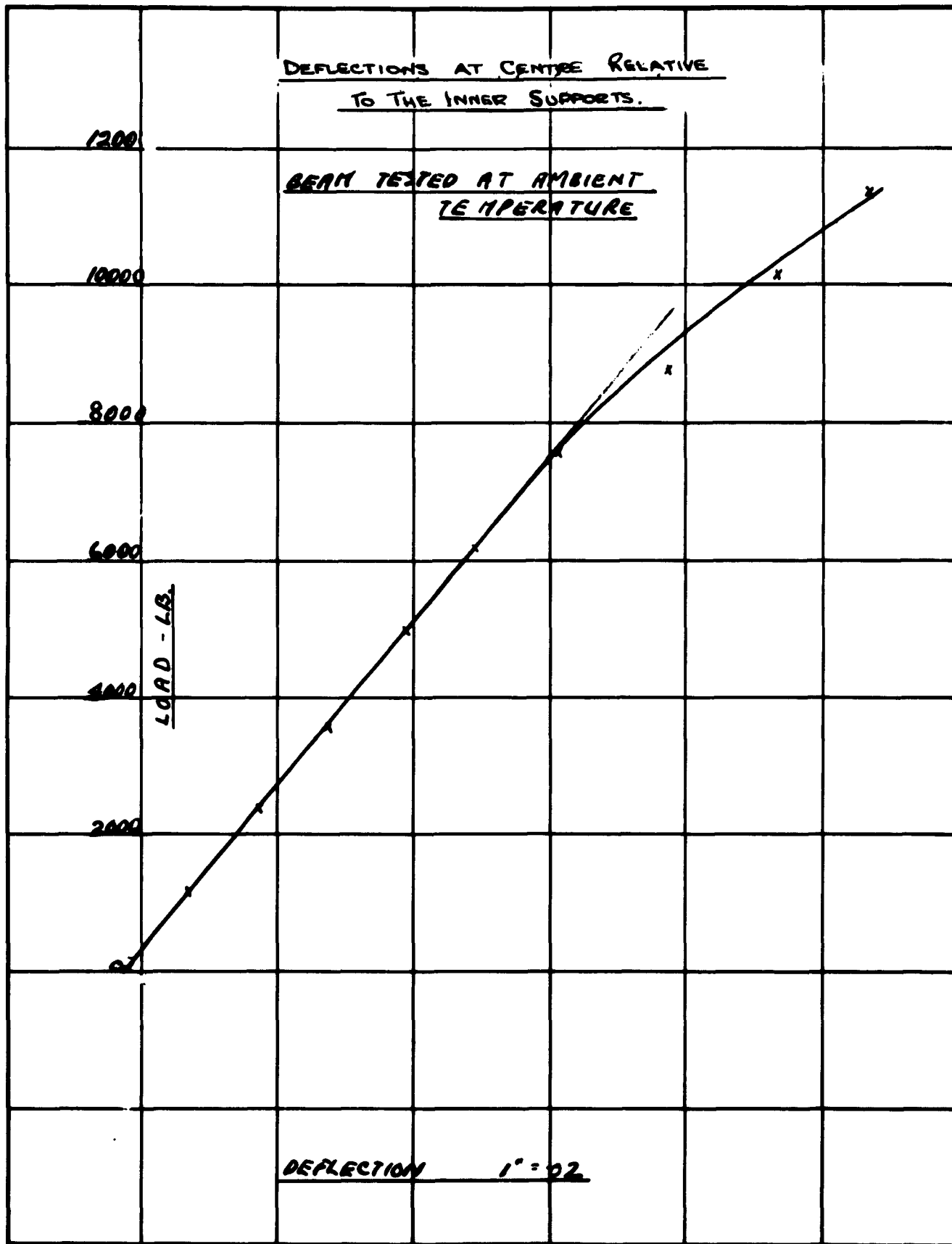

BENDING TEST ON BOX BEAM (DTD 166) SPEC N°1 FIG. 52

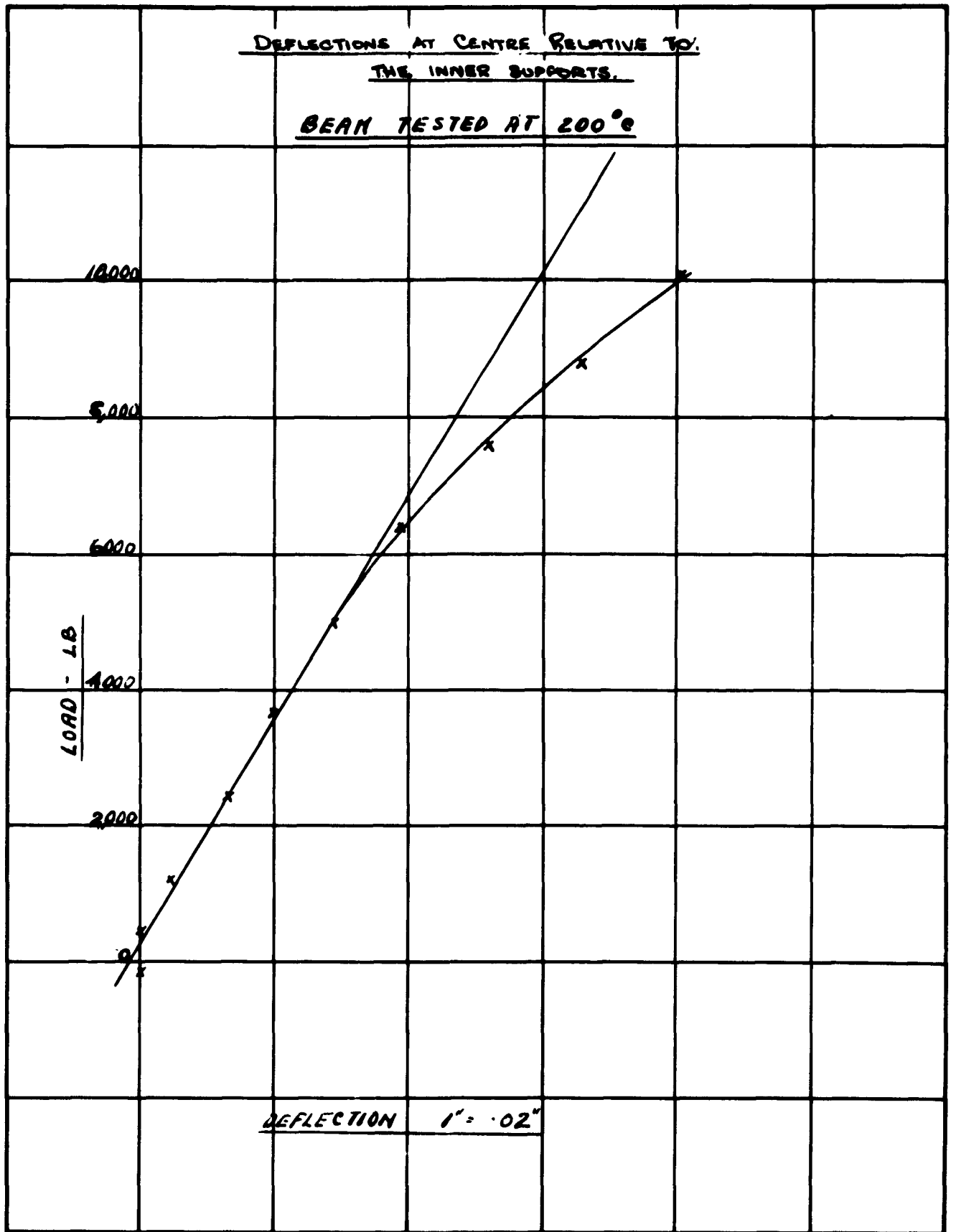

BENDING TEST ON BOX BEAM (OTO 166)

SPEC N° 2

FIG.
53

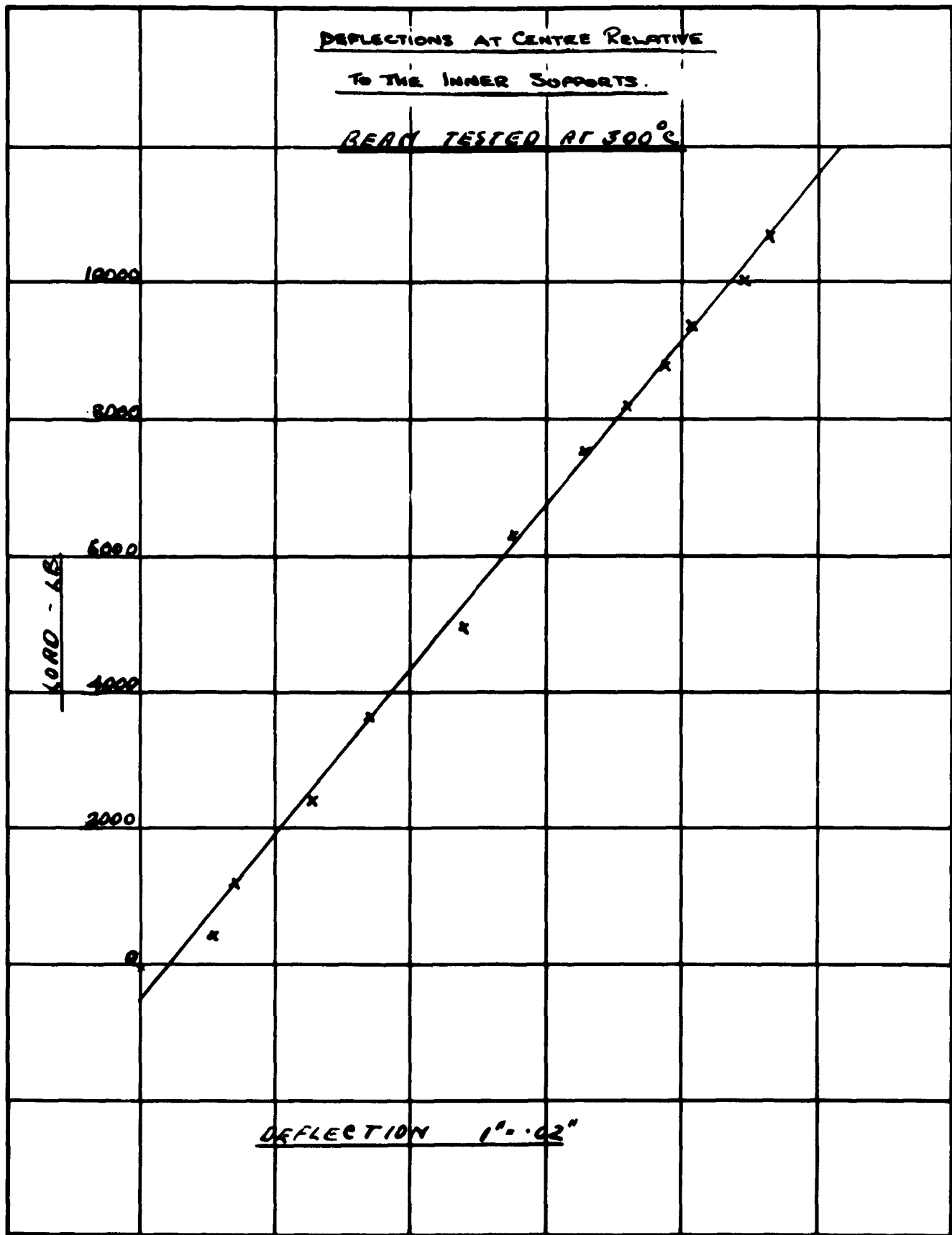

BENDING TEST ON BOX BEAM (OTD 166) SPEC N° 3

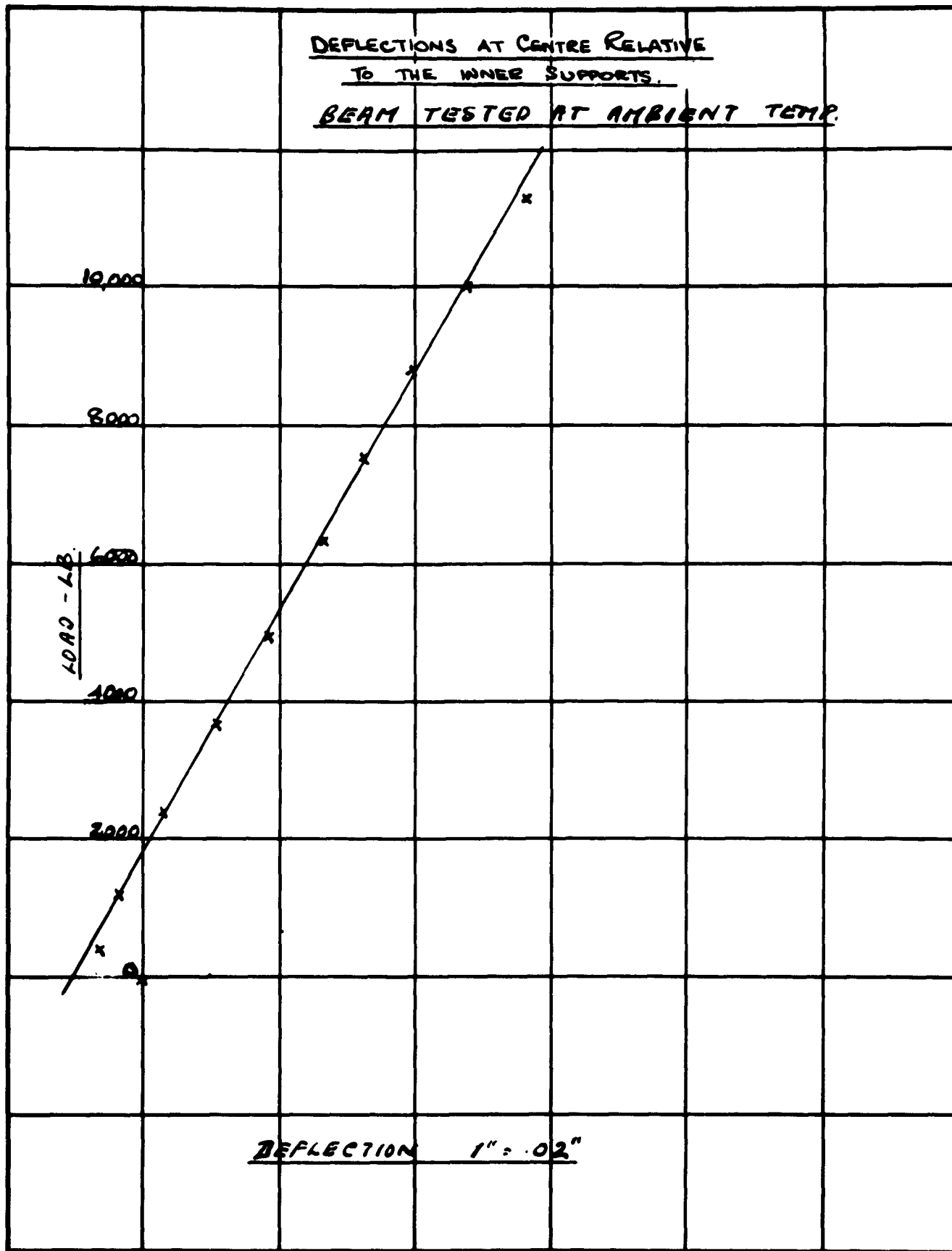

BENDING TEST ON BOX BEAMS (FIRST VICKER 520) SPEC N° 4

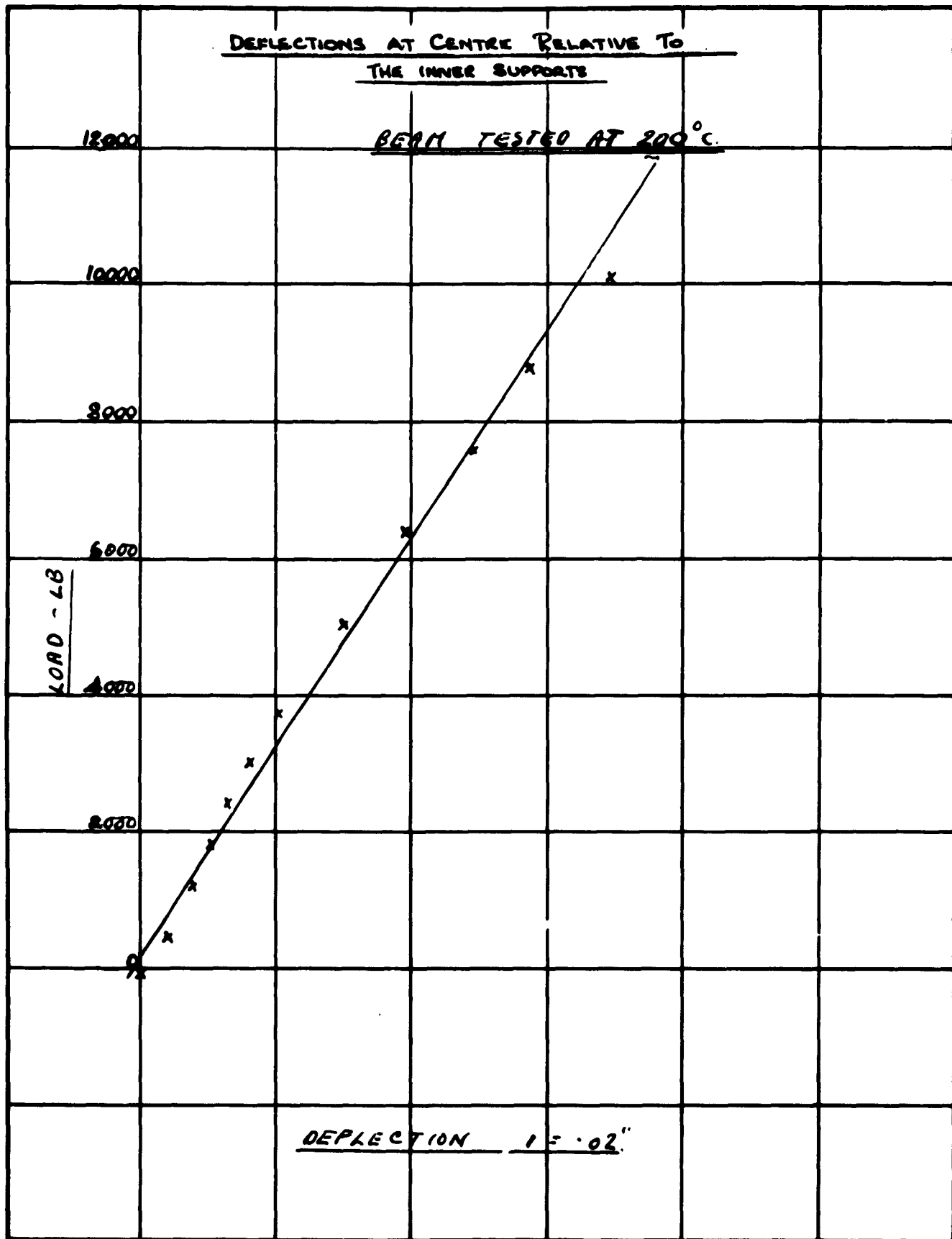

BENDING TEST ON BEAM (FIRTH VICKERS S20) SPEC N° 5 FIG. 56

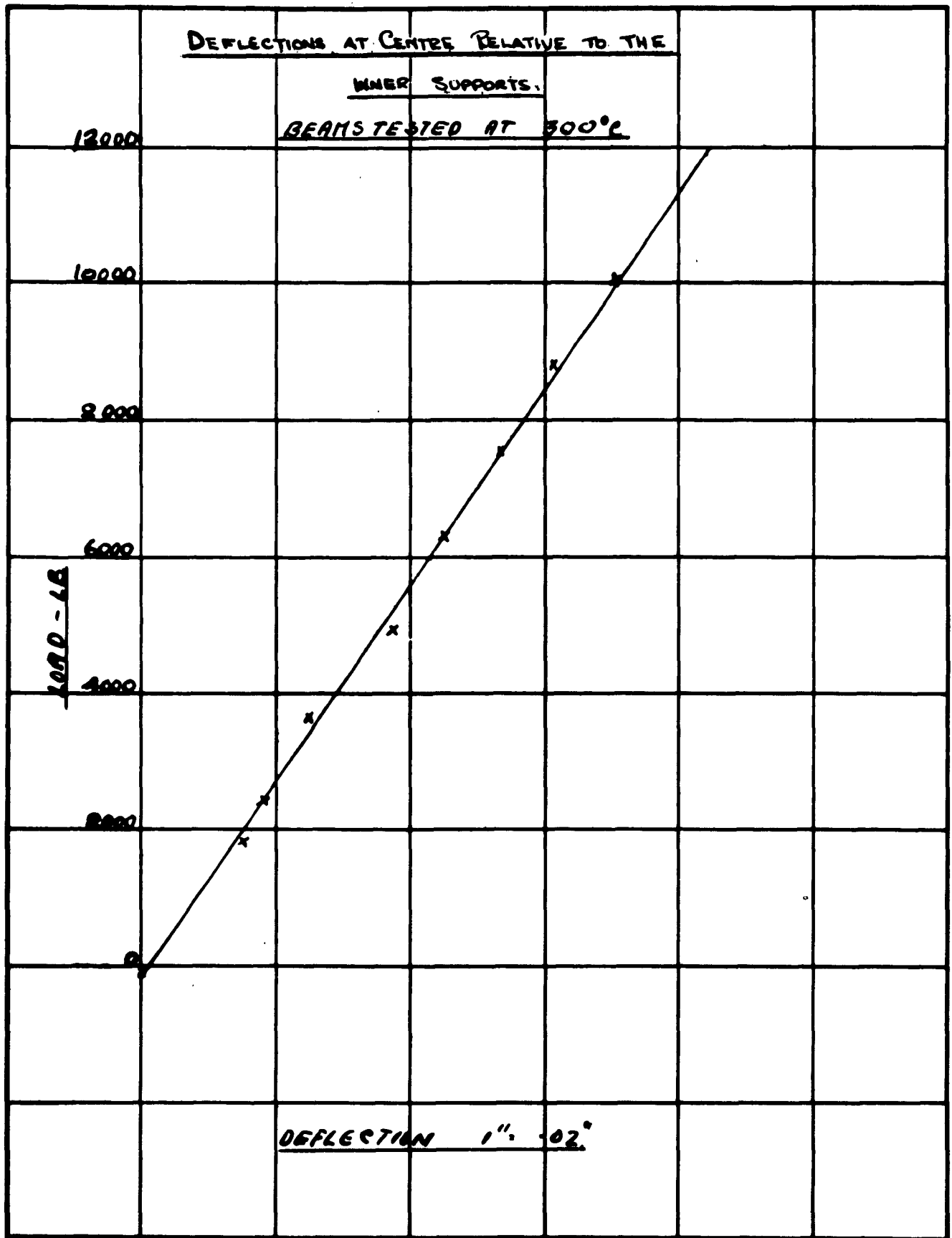

BENDING TEST ON BOX BEAM (FIRM VICKERS S20) SPEC N° 6 FIG. 54

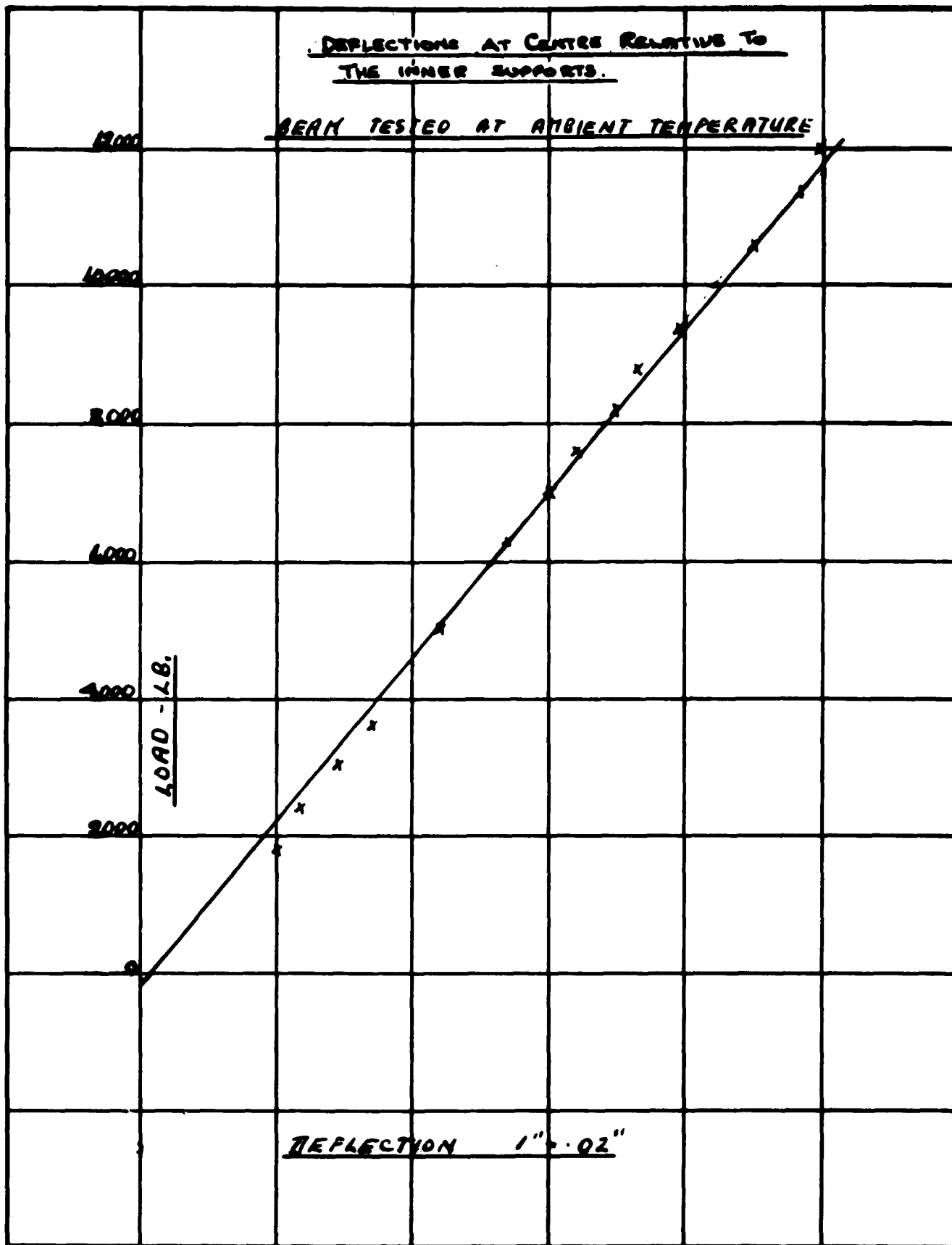

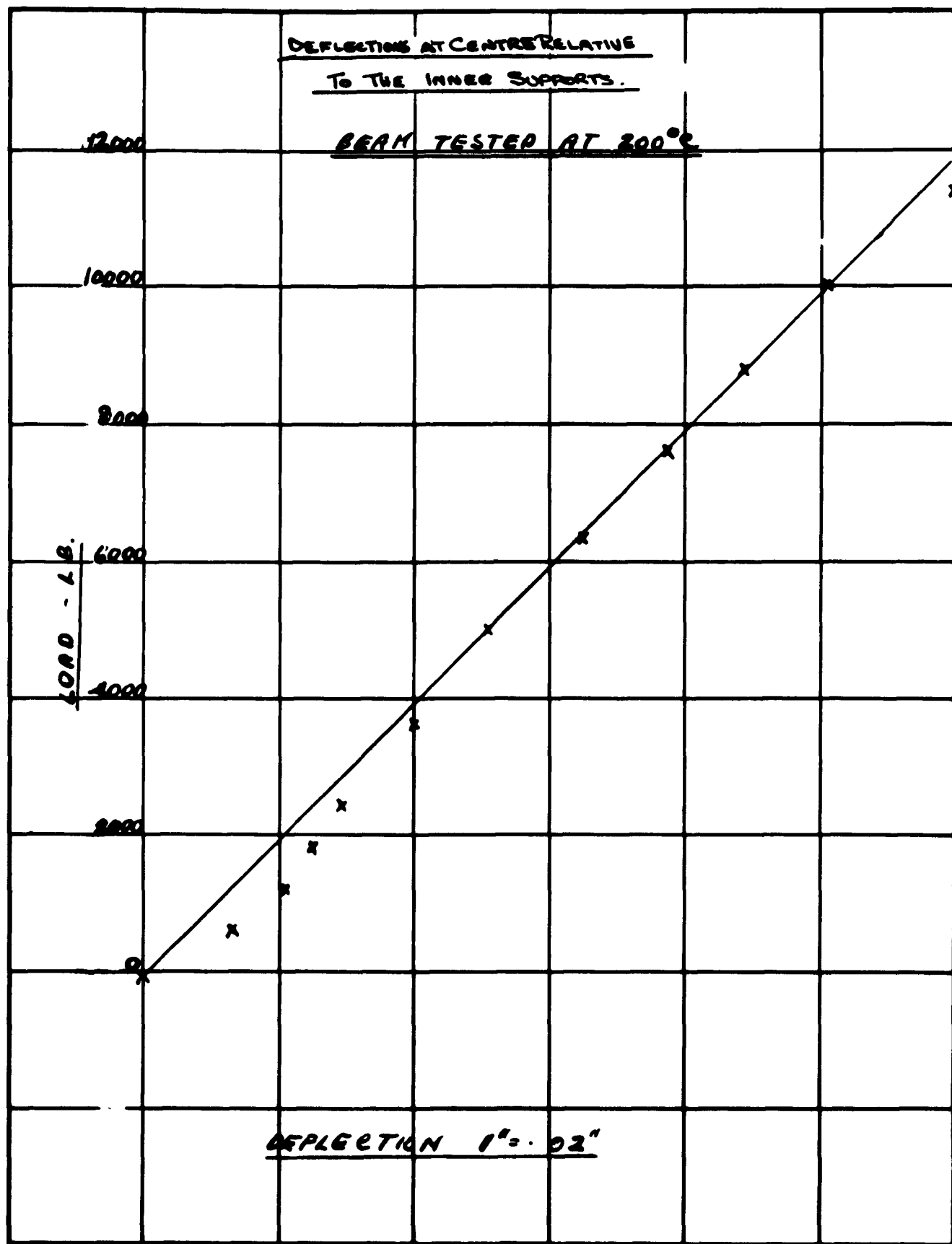

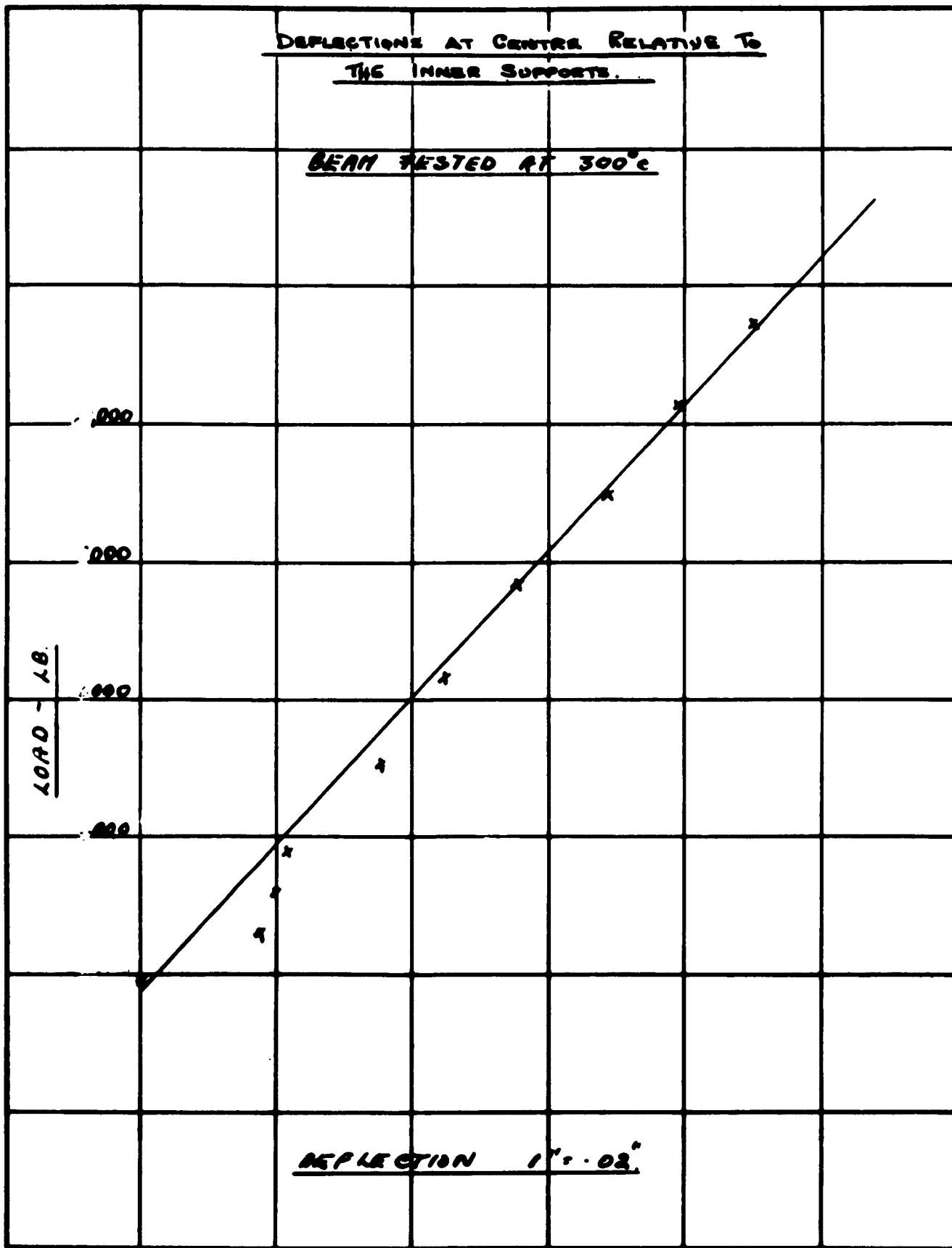

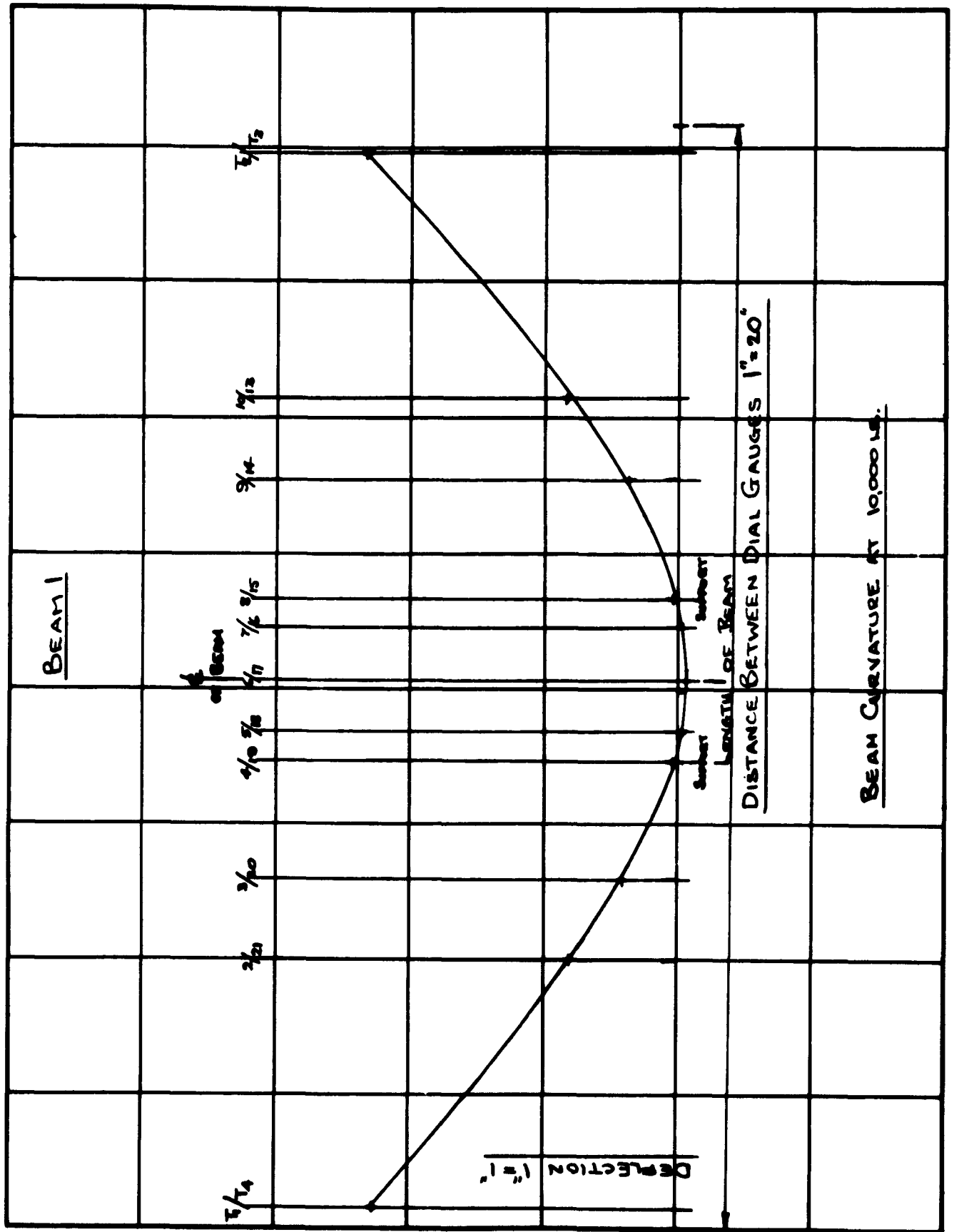

BENDING TESTS ON BOX BEAMS. SPEC. No. 1.

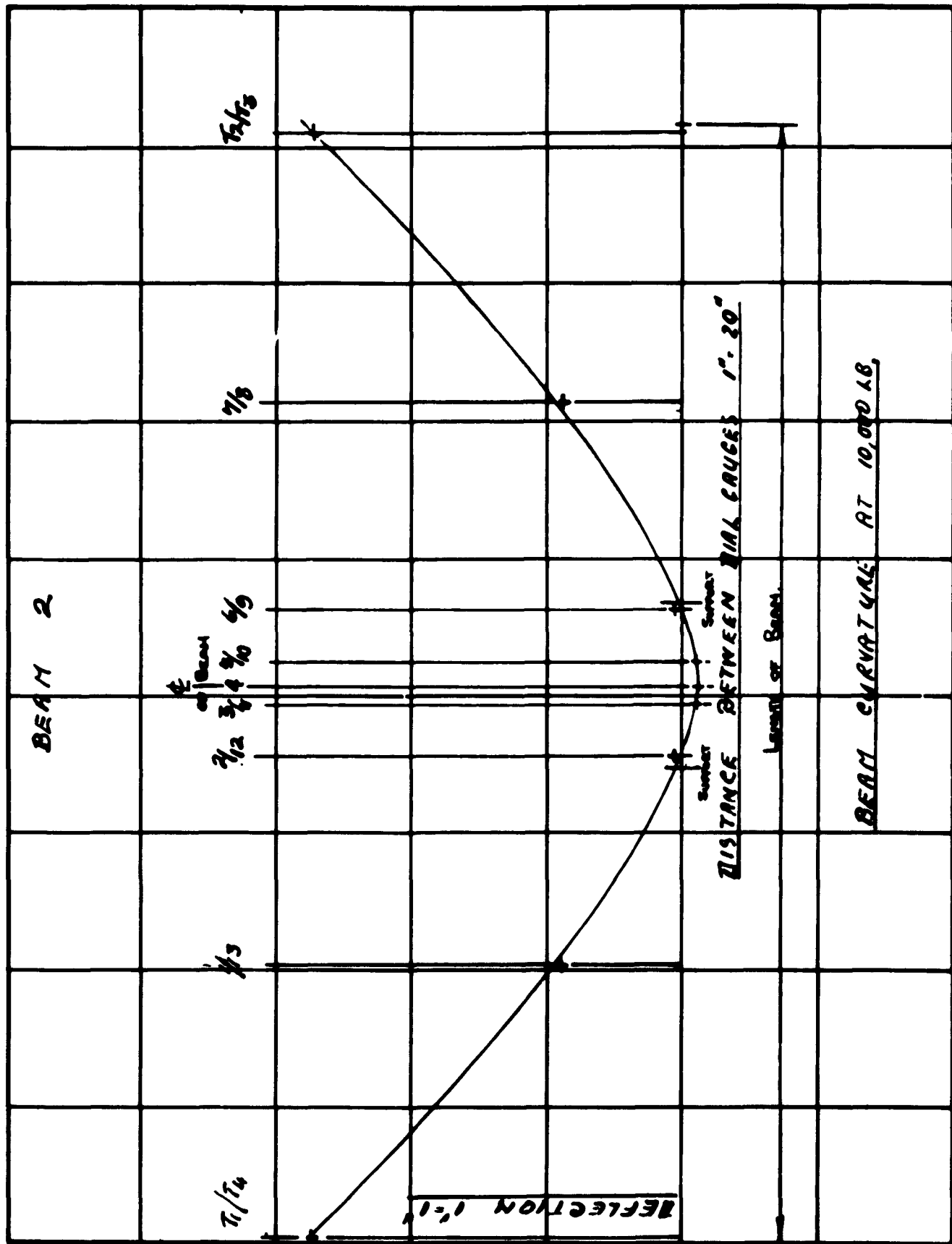

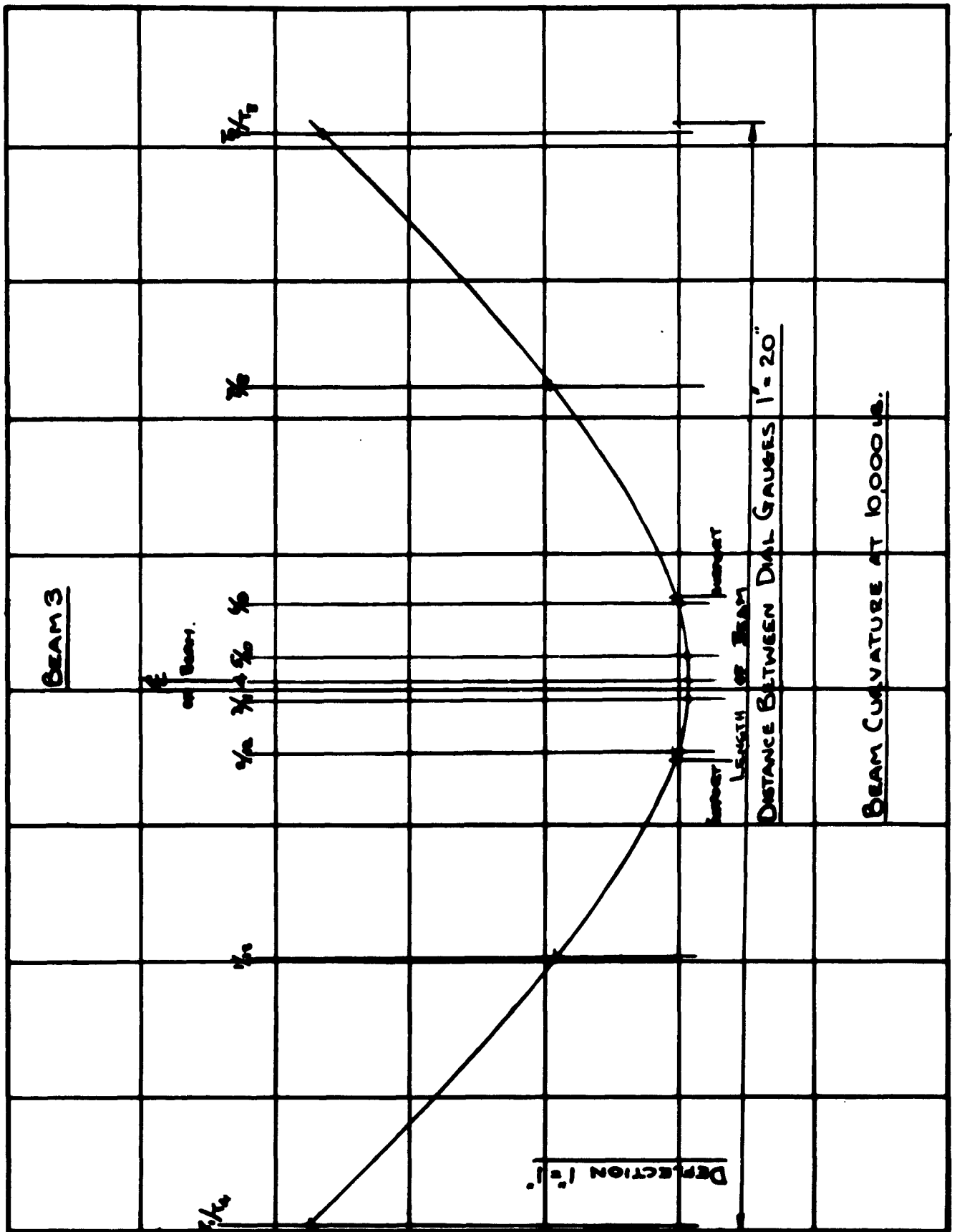

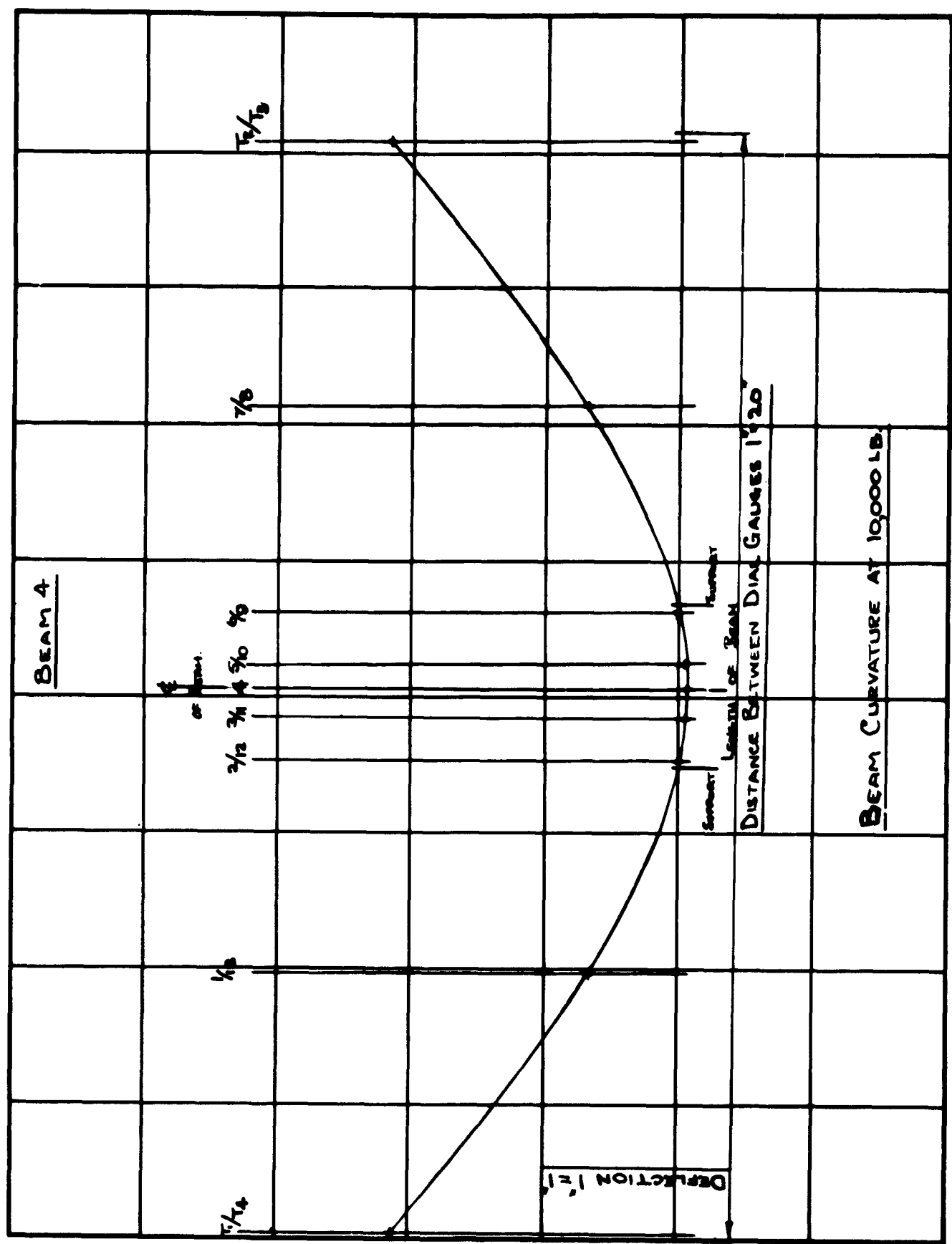

BENDING TESTS ON BOX BEAMS. SPEC. No. 4

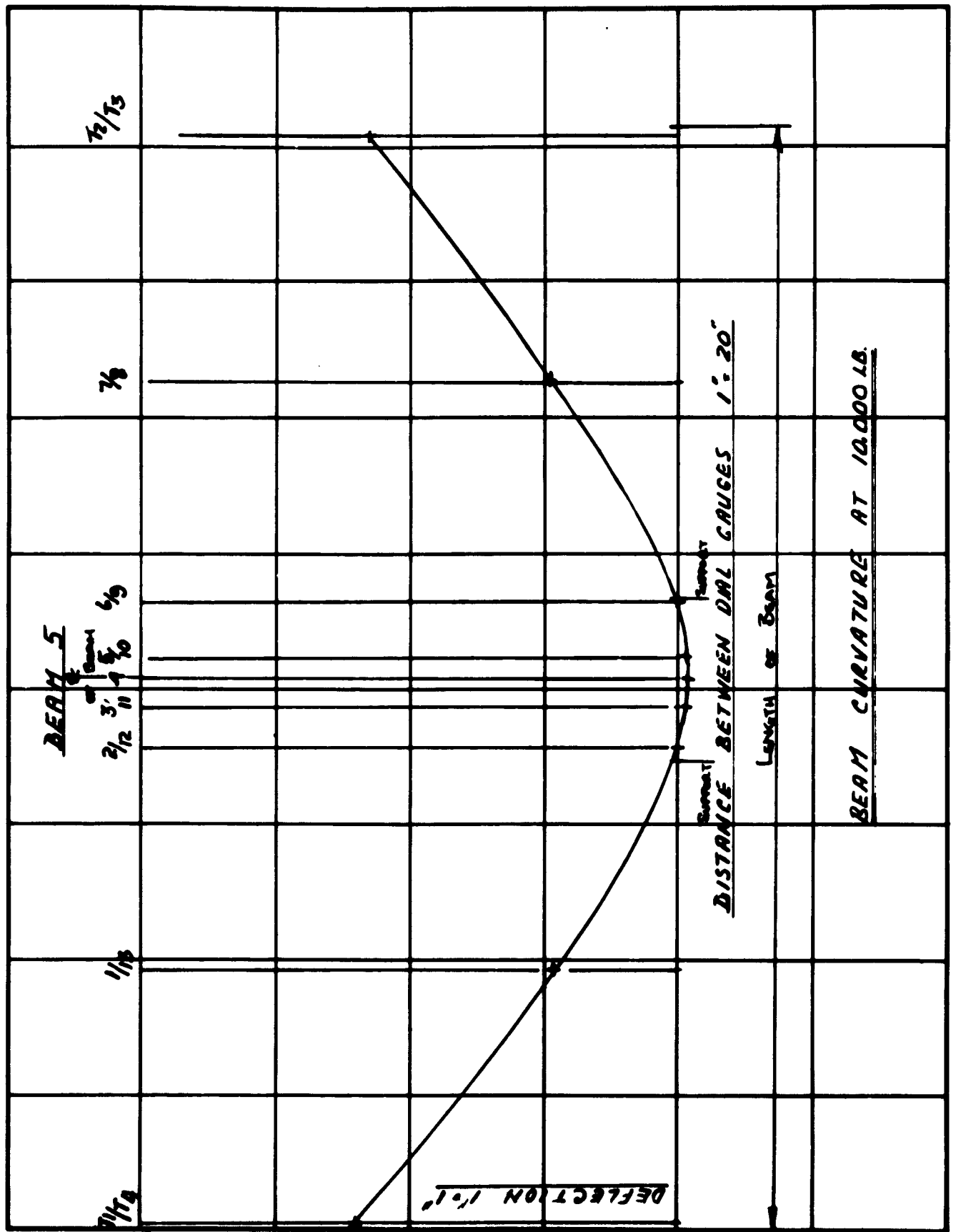

BOX BEAM BENDING TEST SPEC NO 5

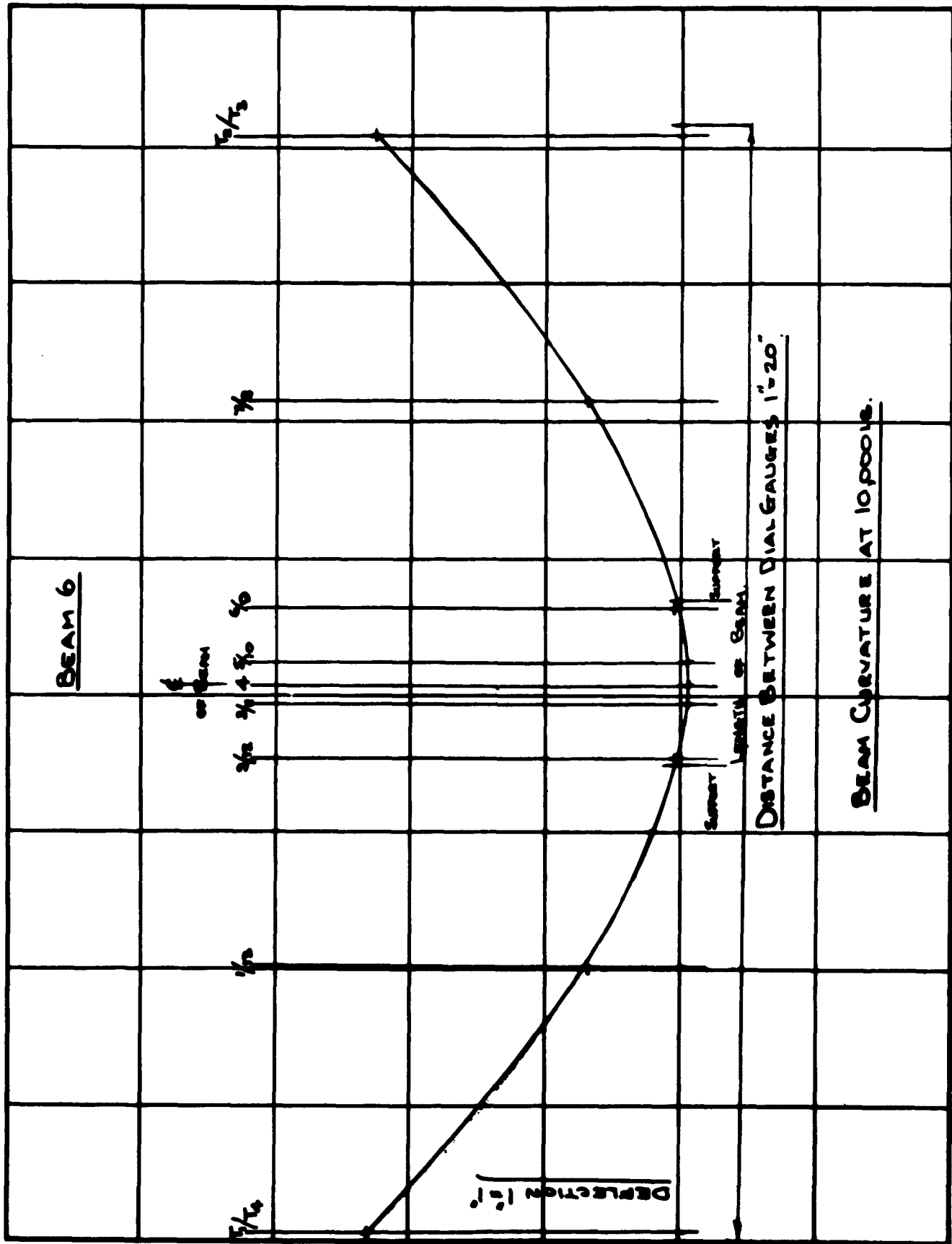

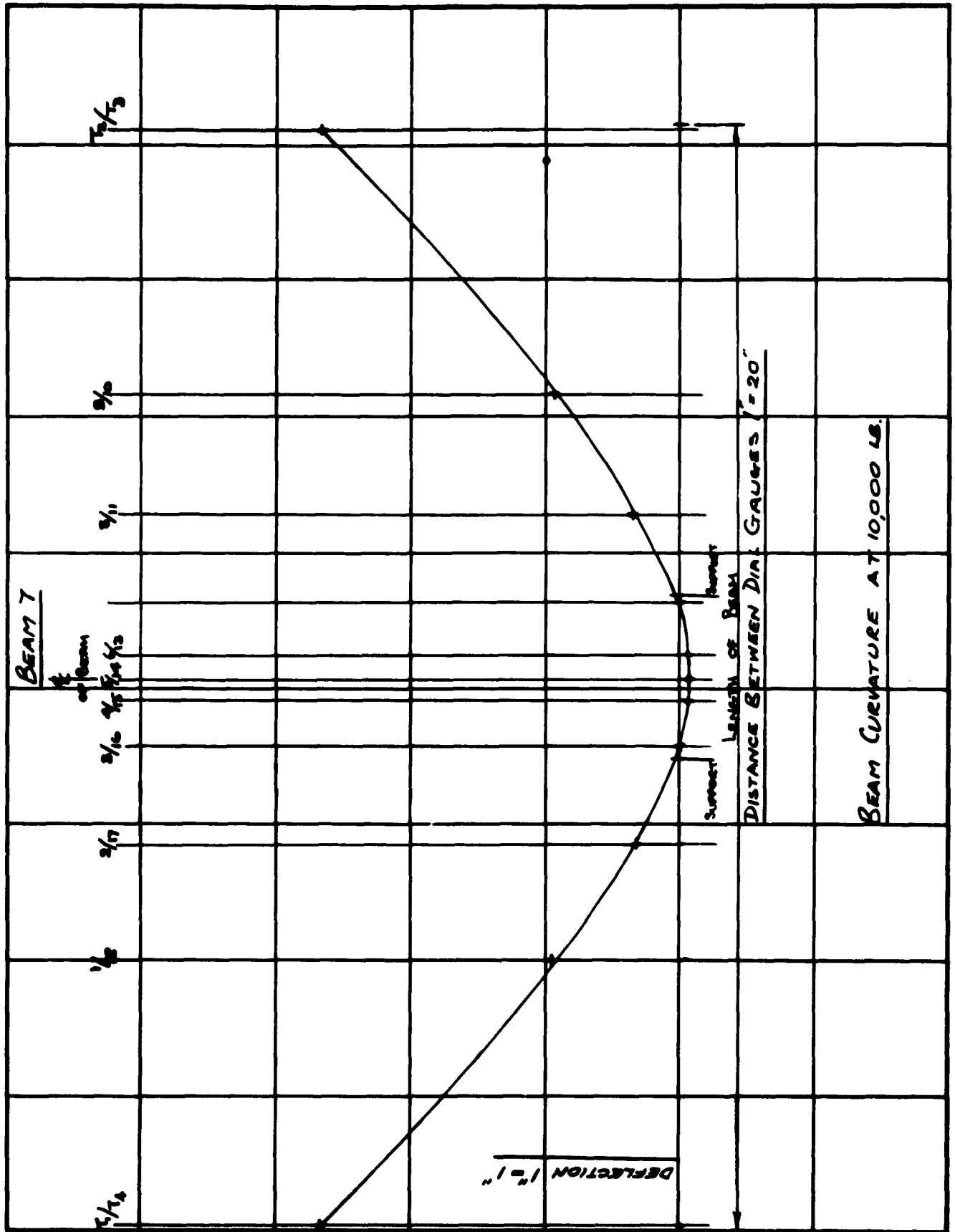

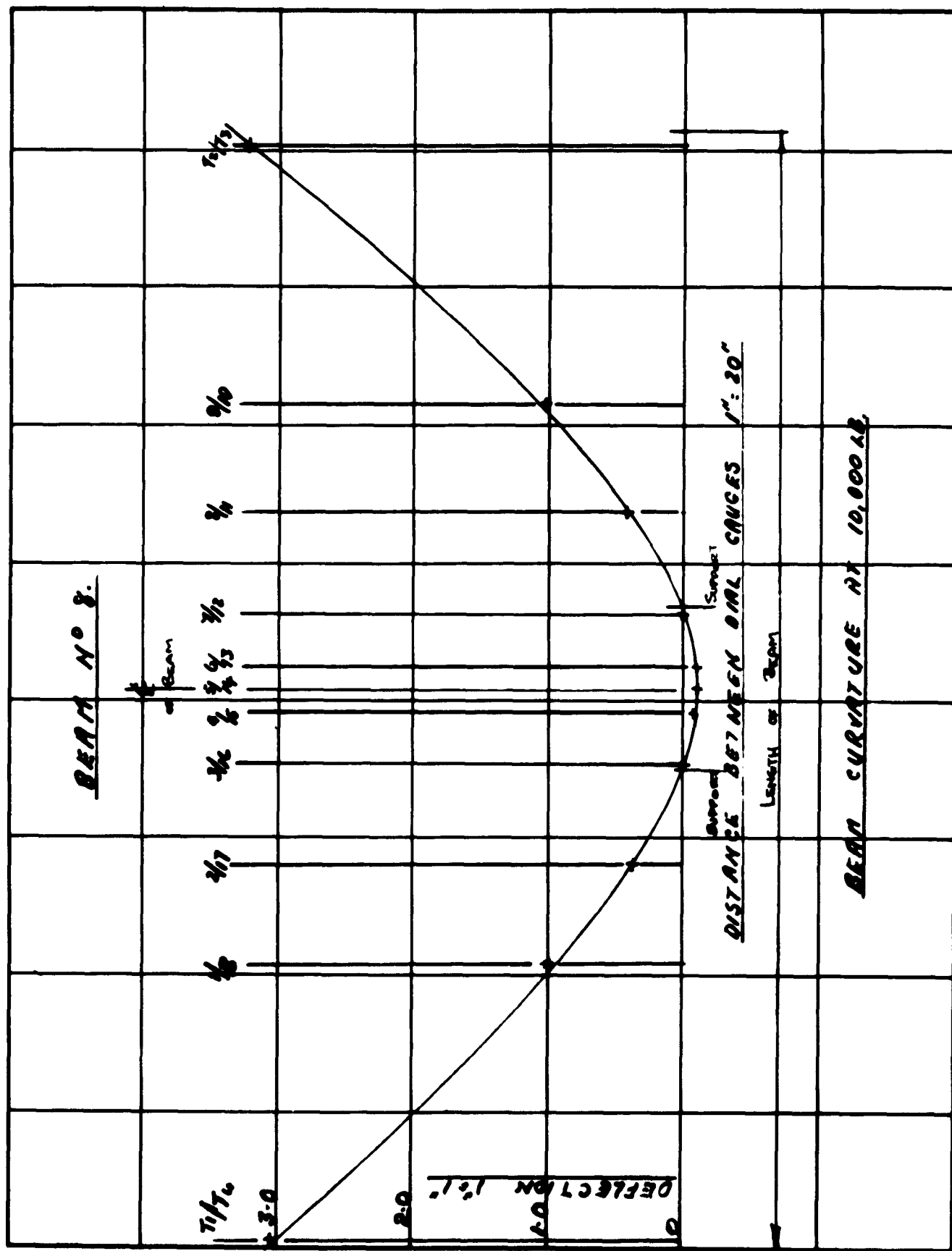

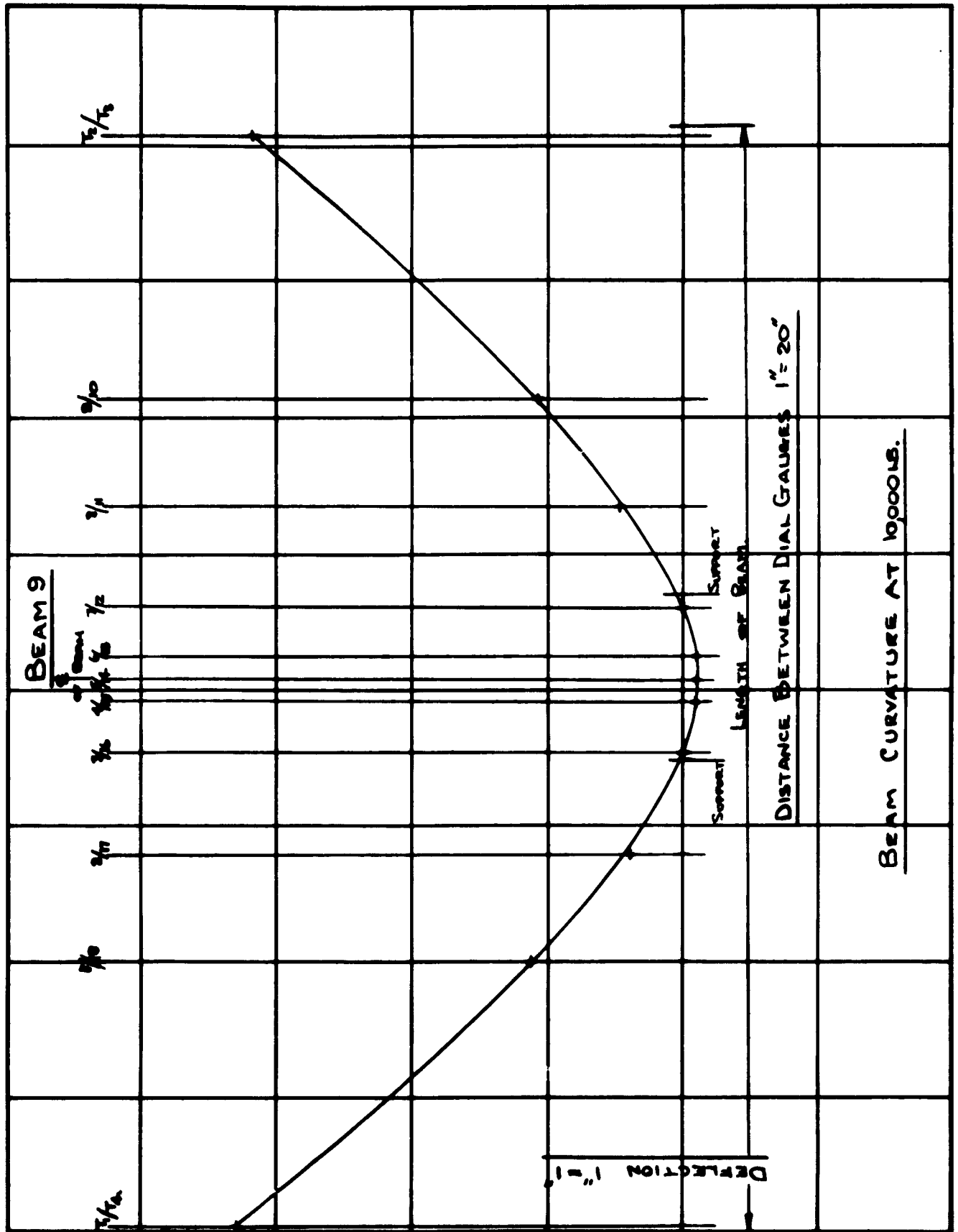

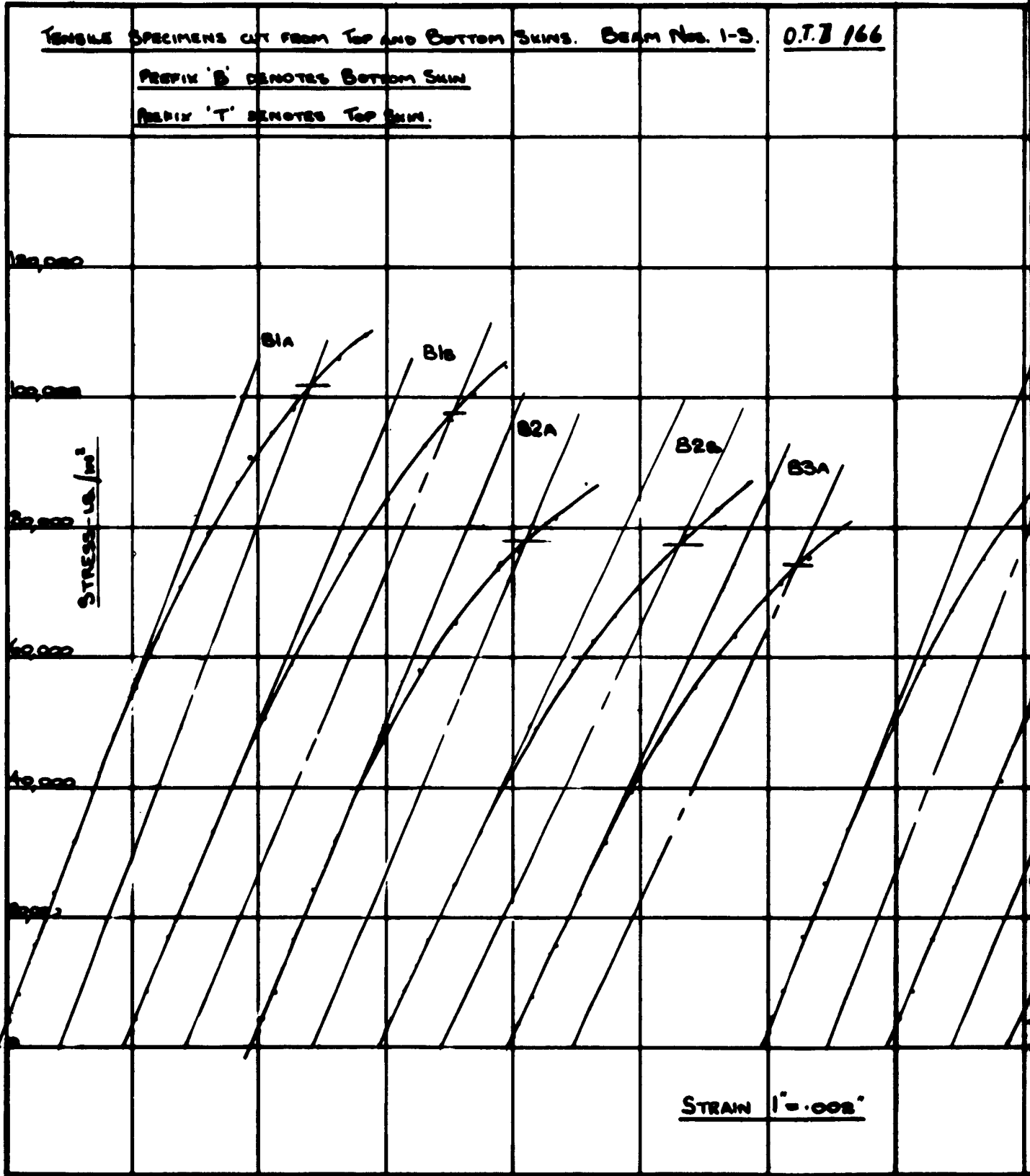

1

BOX BEAM TENSILE CONTROL SPECIMENS.

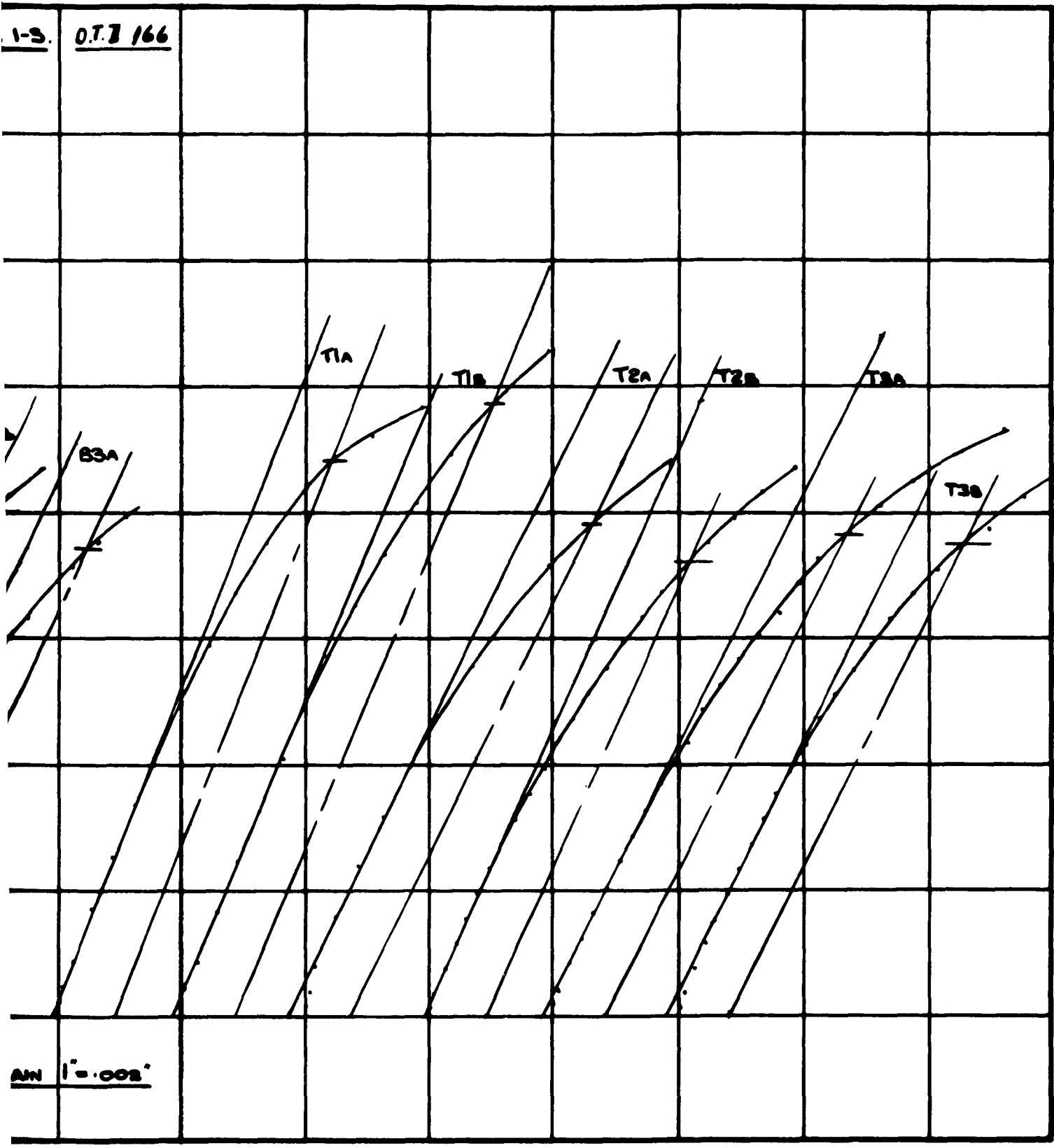

2

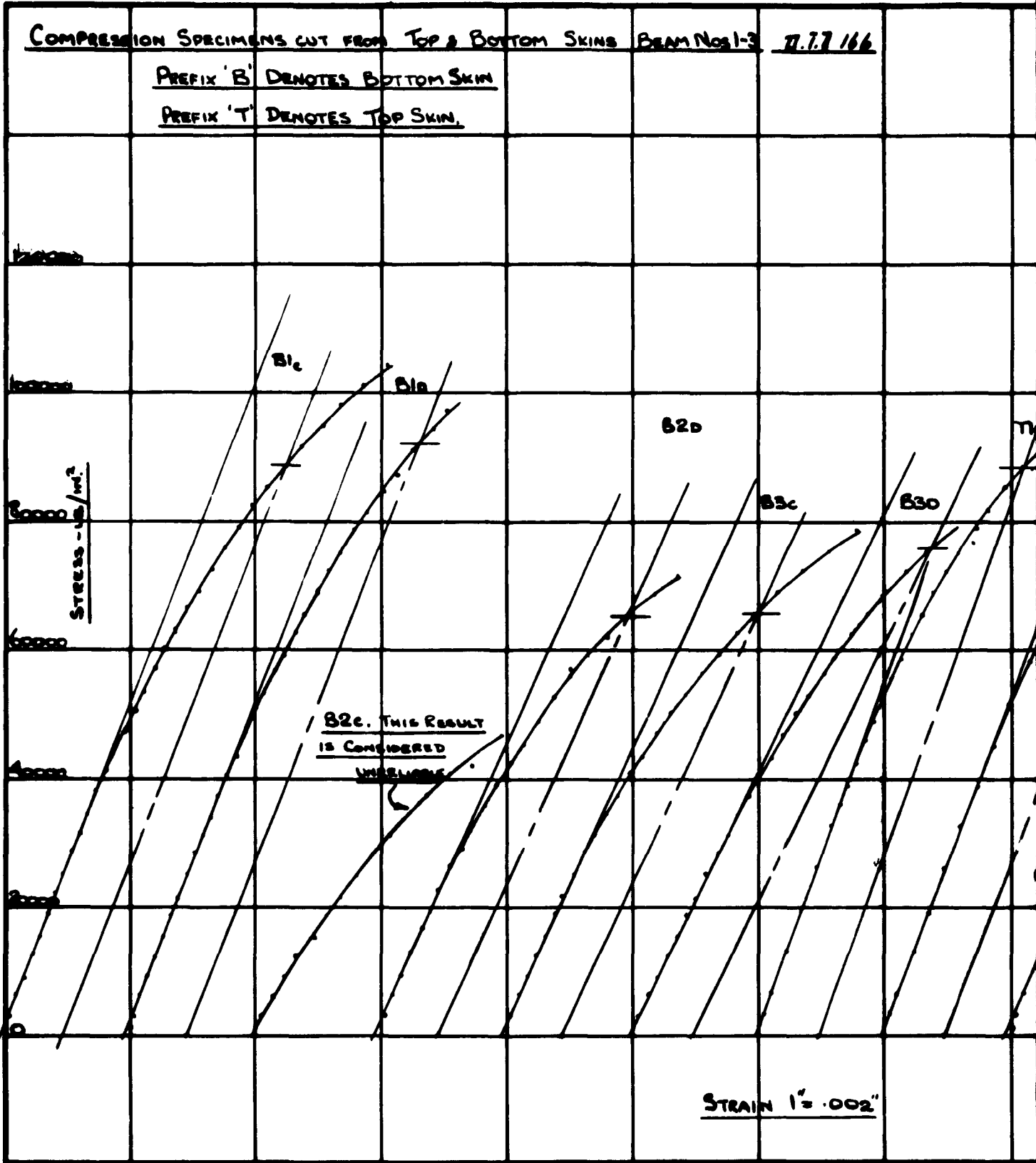

1

BOX BEAM COMPRESSION CONTROL SPECIMENS.

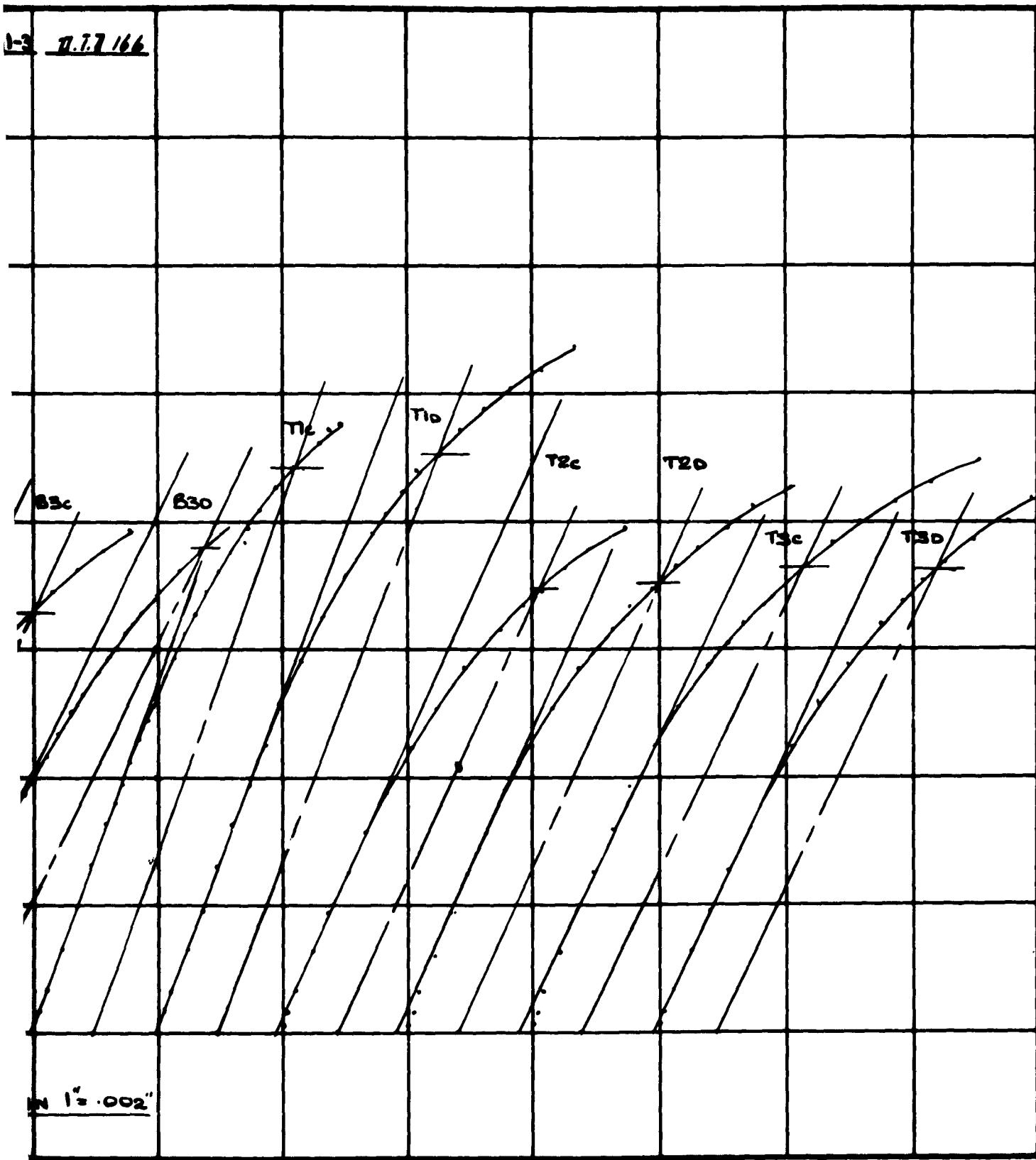

2

SPECIMENS.

FIG. 71

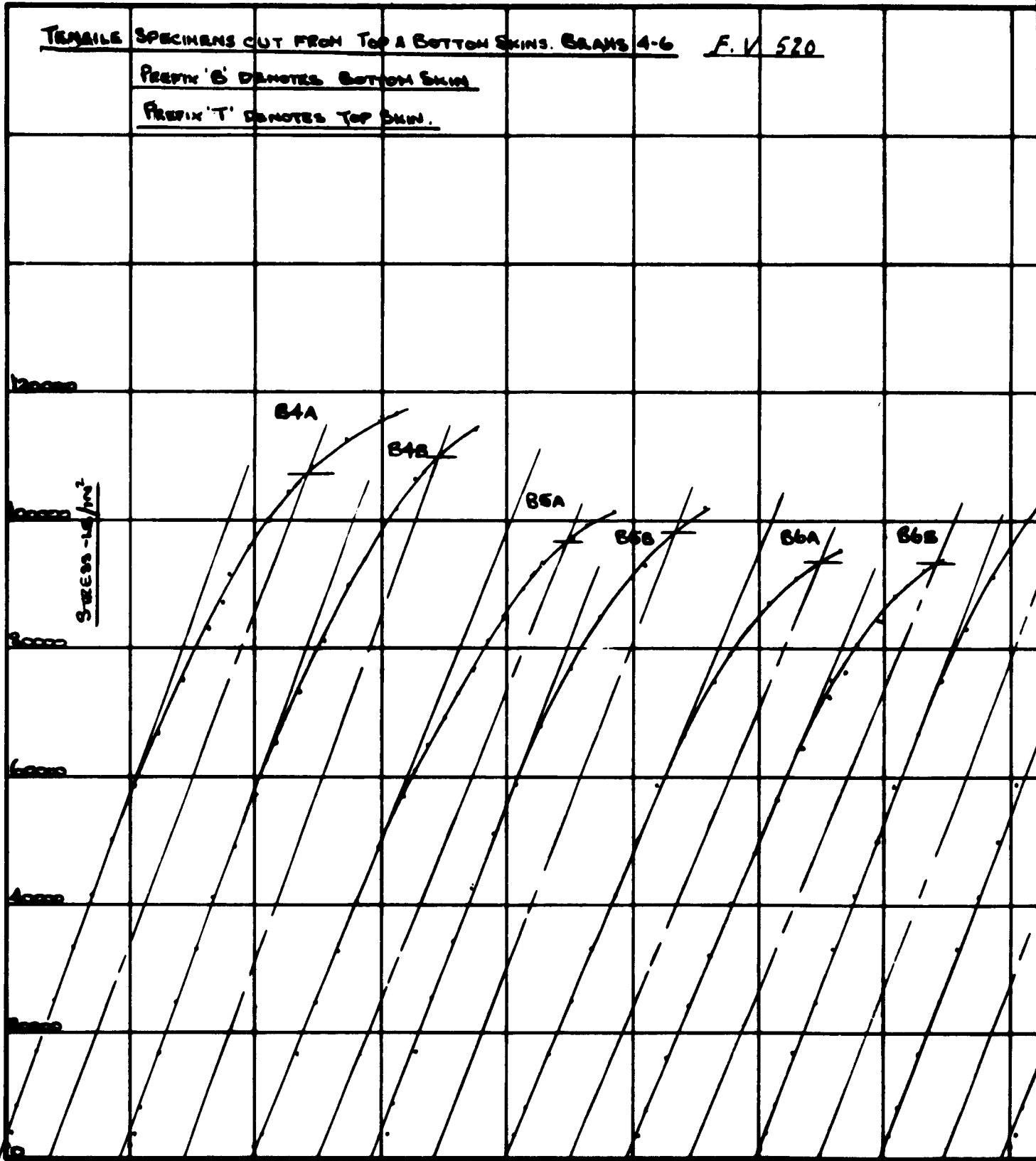

1

BOX BEAM TENSILE CONTROL SPECIMENS.

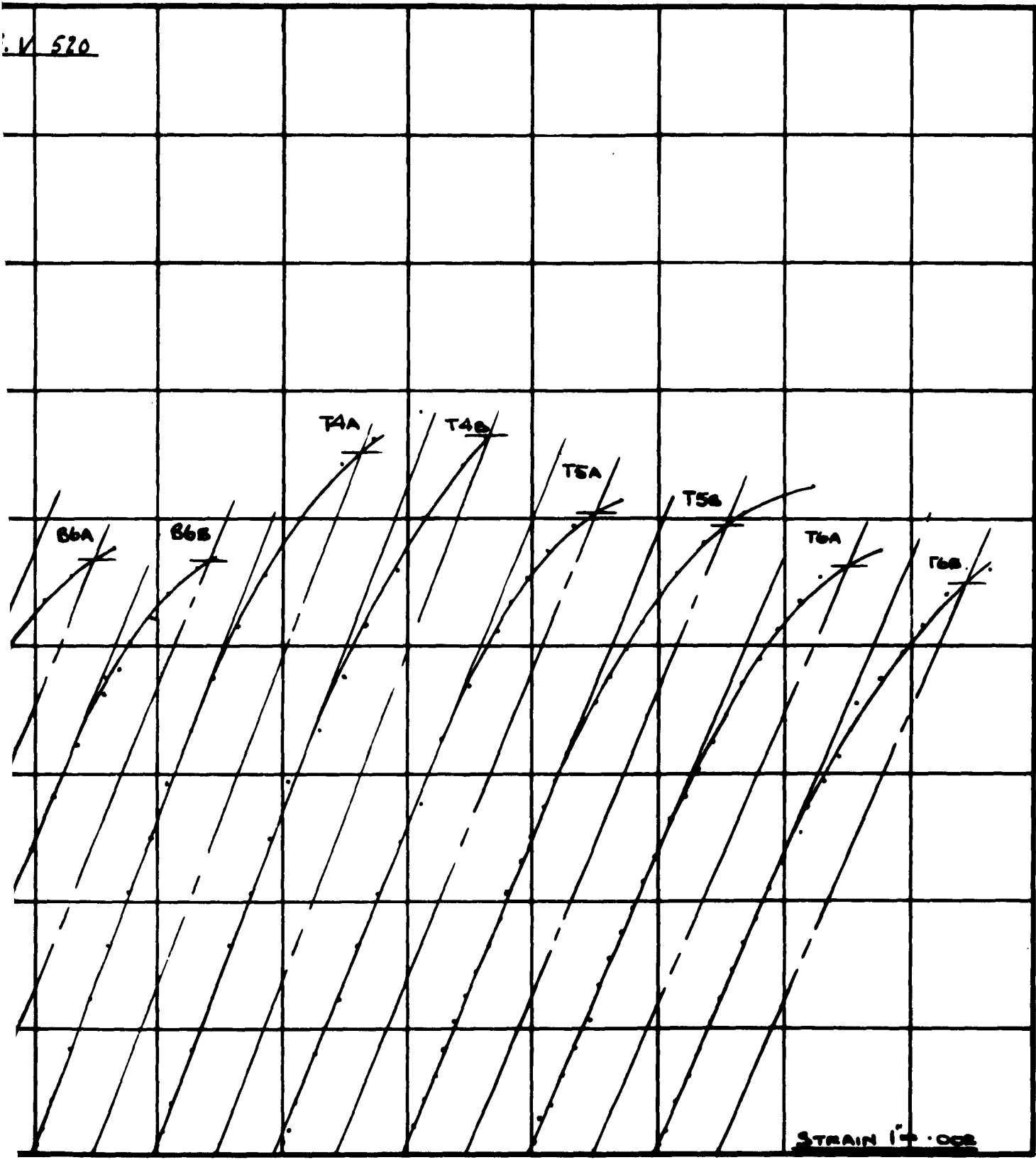

2

FIG. 72

COMPRESSION SPECIMENS CUT FROM TOP & BOTTOM SKINS. BEAMS 4-6. P.P. 520

PREFIX 'B' DENOTES BOTTOM SKIN

PREFIX 'T' DENOTES TOP SKIN

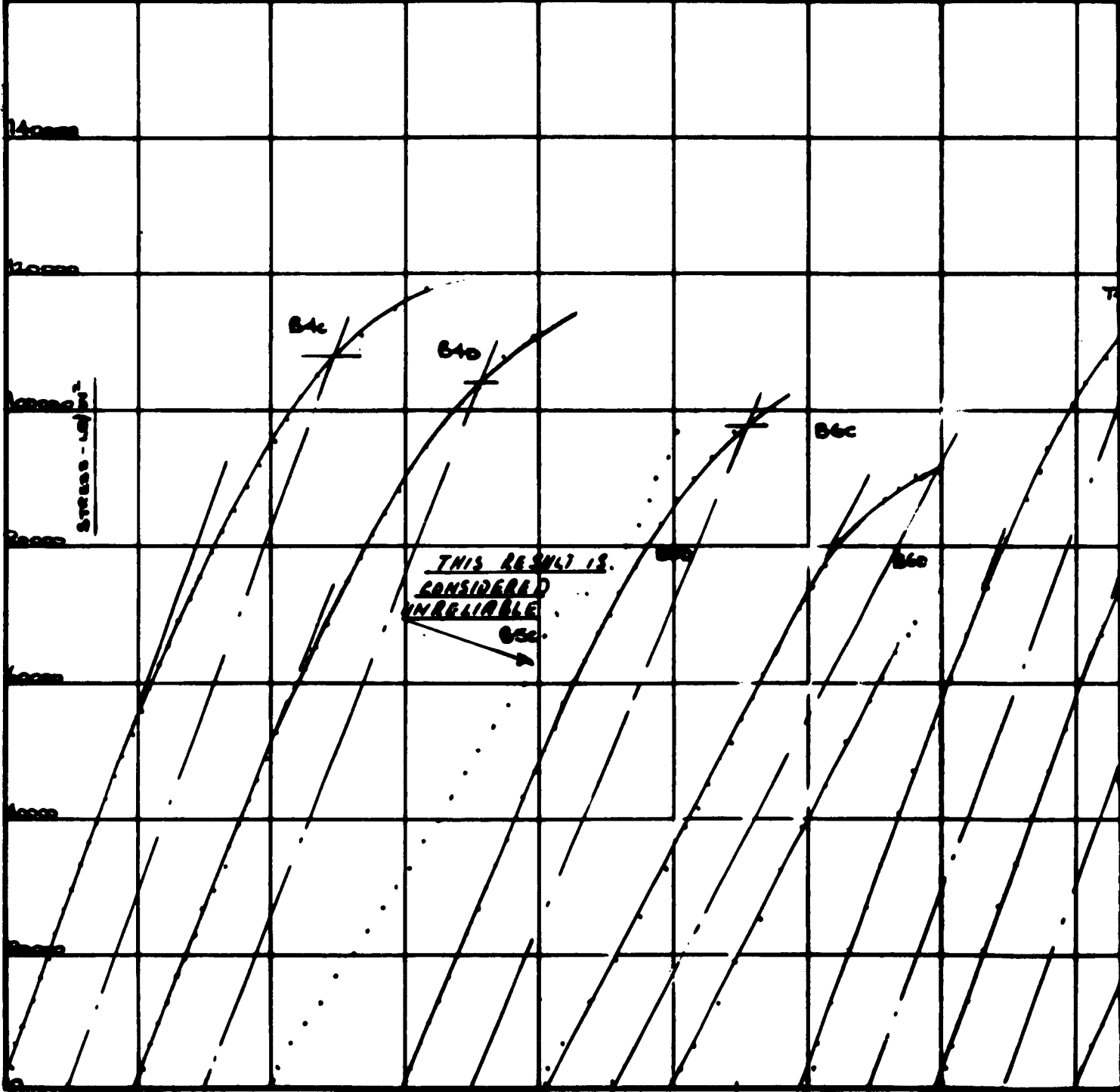

1

BOX BEAM COMPRESSION CONTROL SPECIMENS.

P. 520

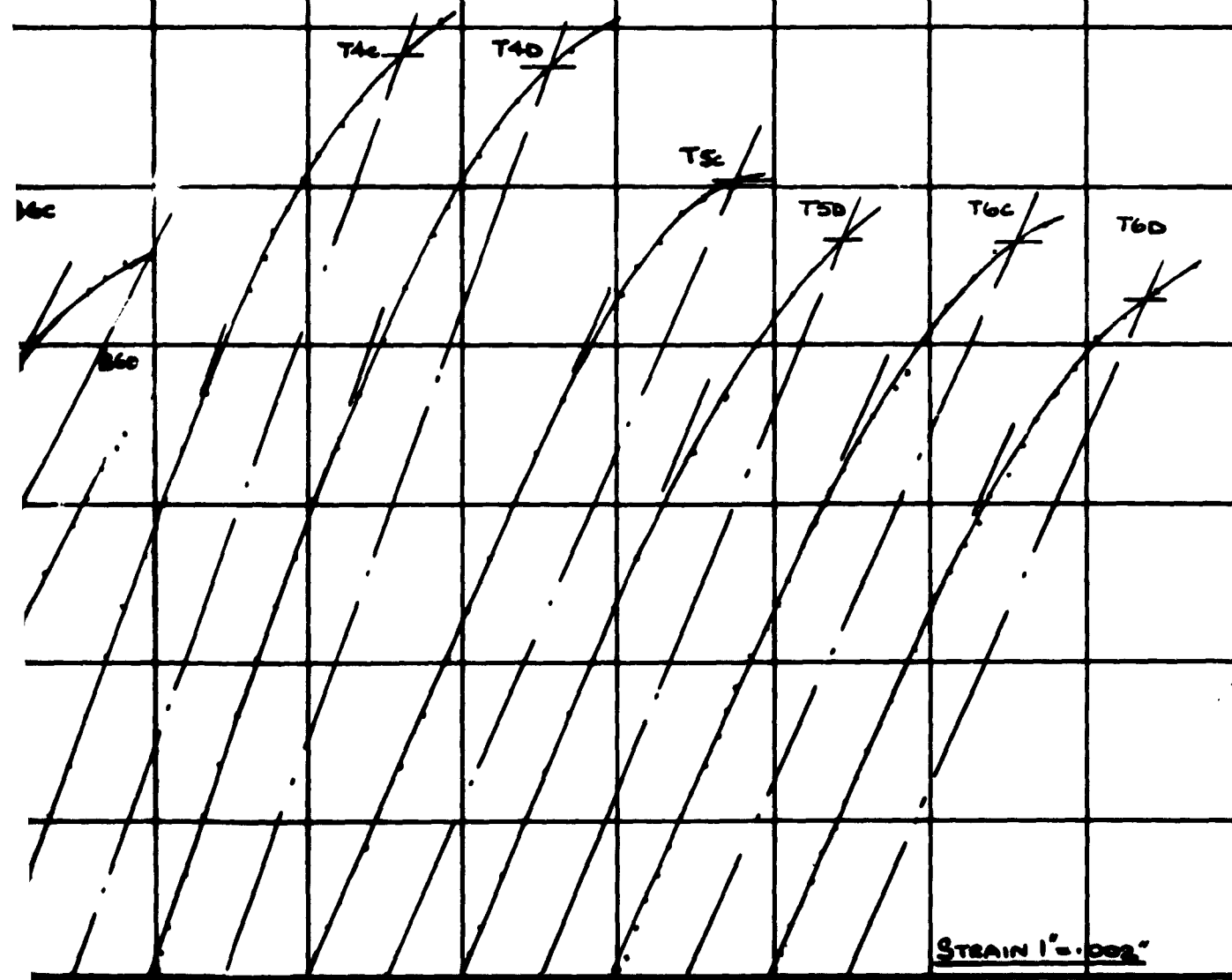

2

PG.
73

2.

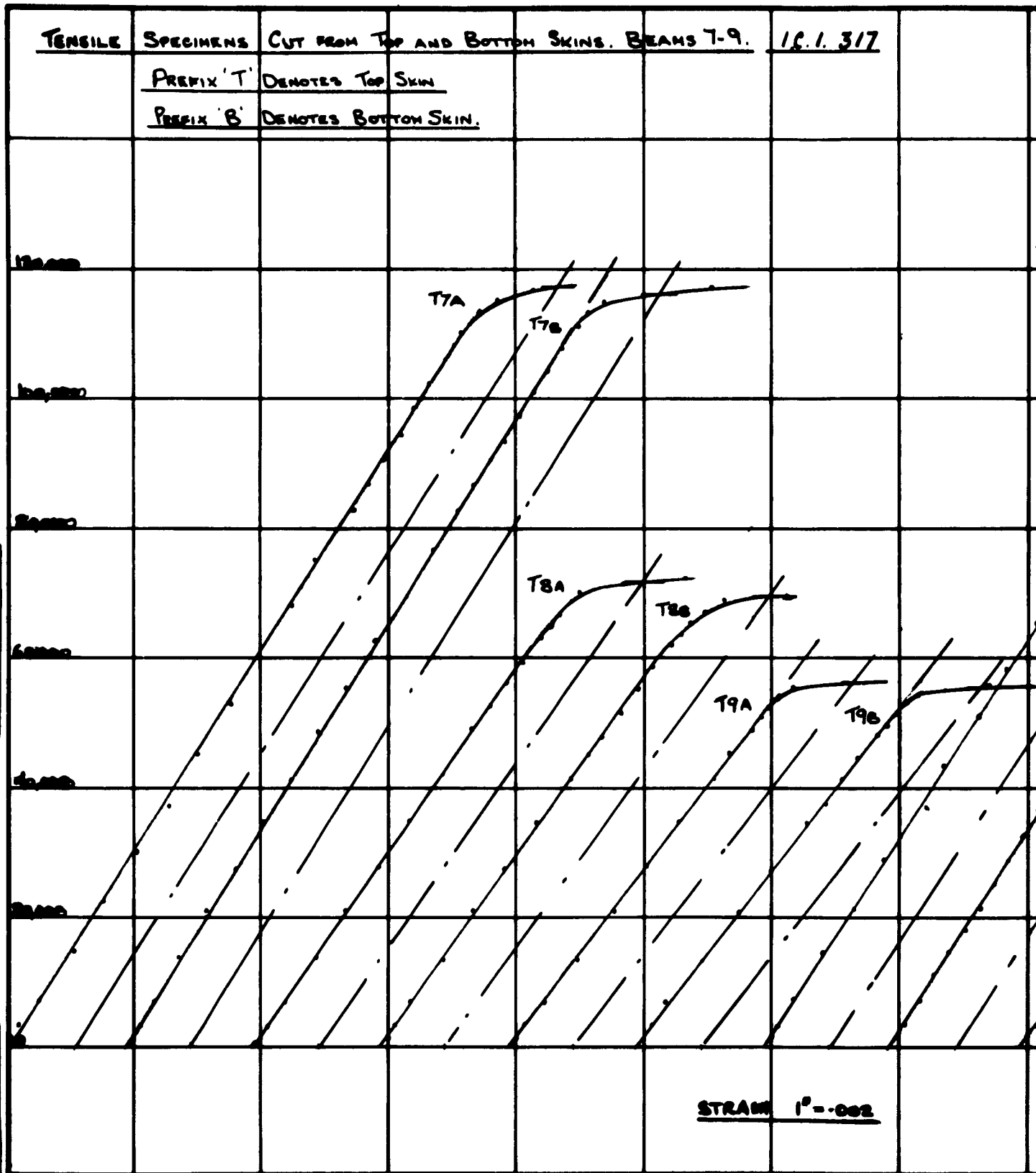

BOX BEAM TENSILE CONTROL SPECIMENS.

10.1.317

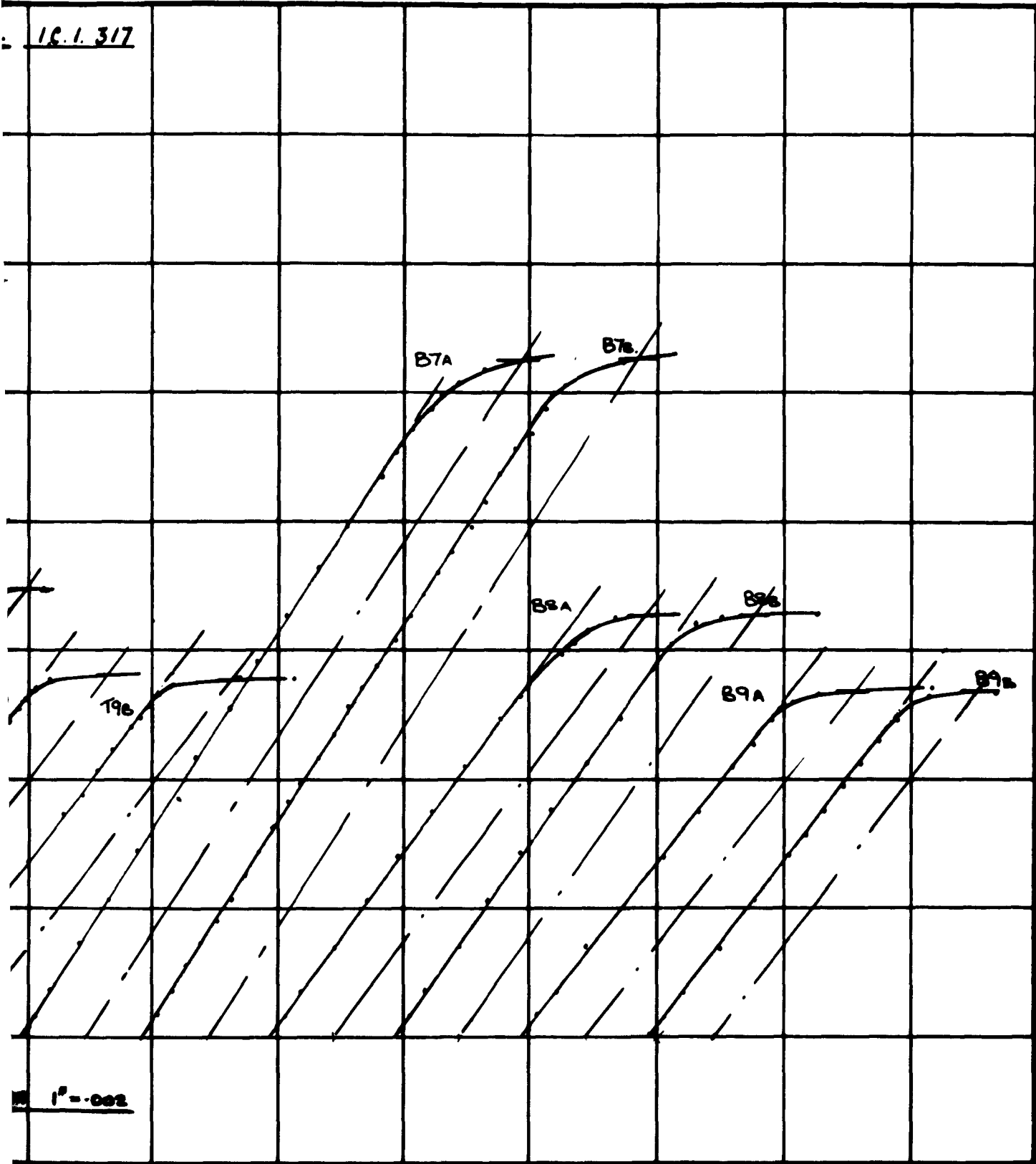

2

FIG.
74

COMPRESSION SPECIMENS CUT FROM TOP & BOTTOM SKINS, BEAMS 7-9 12.1.317

PREFIX 'B' DENOTES BOTTOM SKIN

PREFIX 'T' DENOTES TOP SKIN.

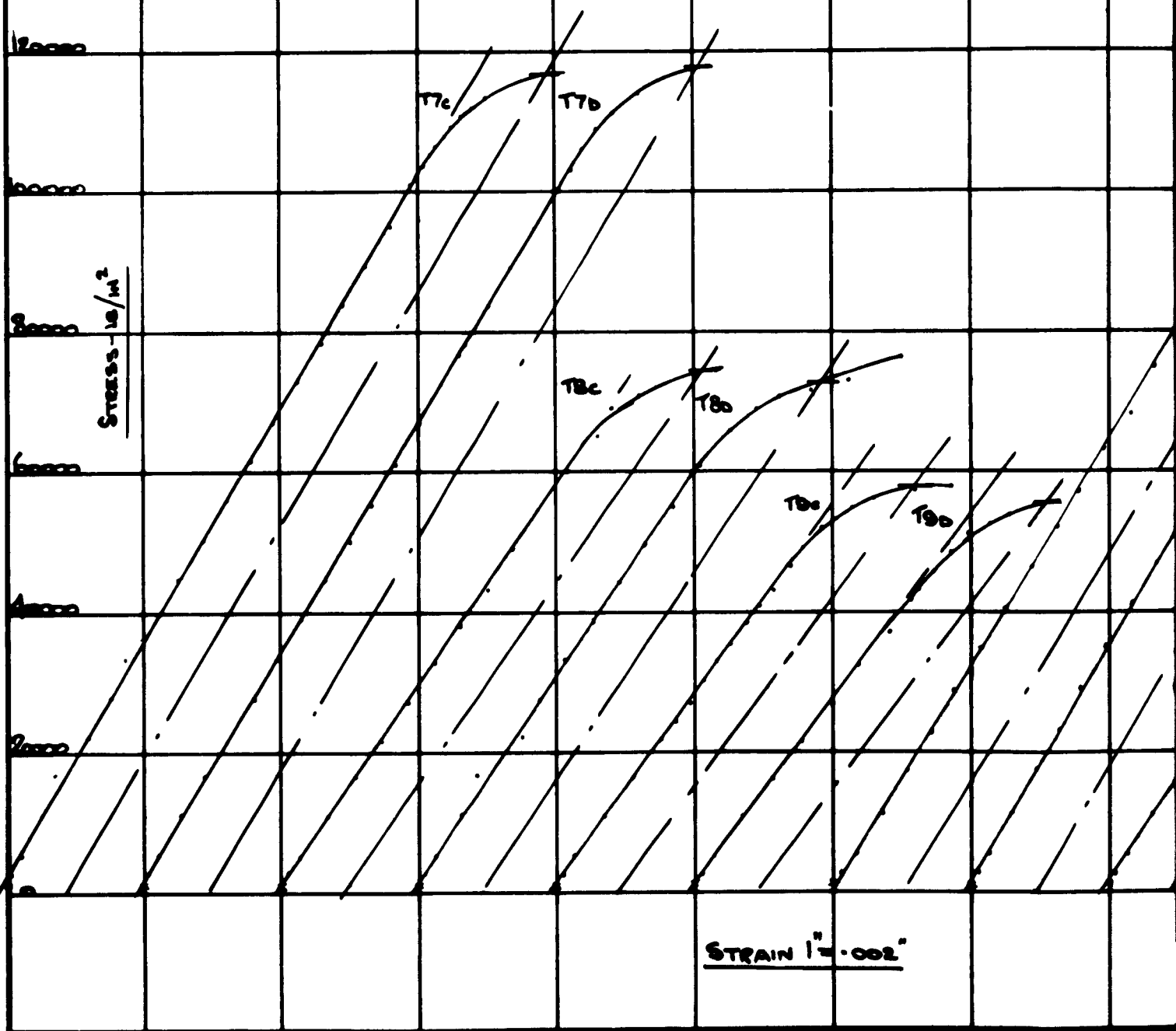

BOX BEAM COMPRESSION CONTROL SPECIMENS.

16.1.317

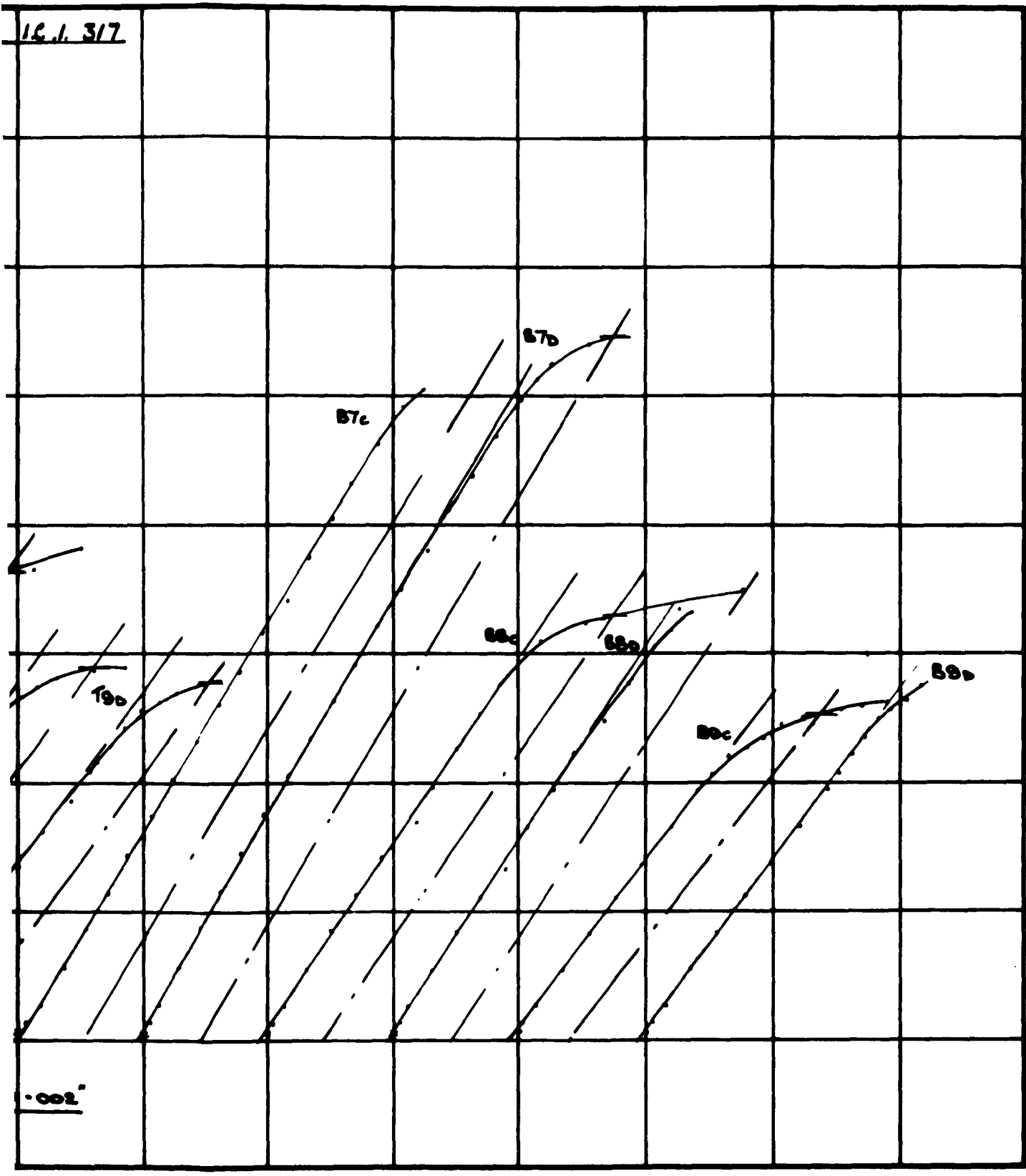

2

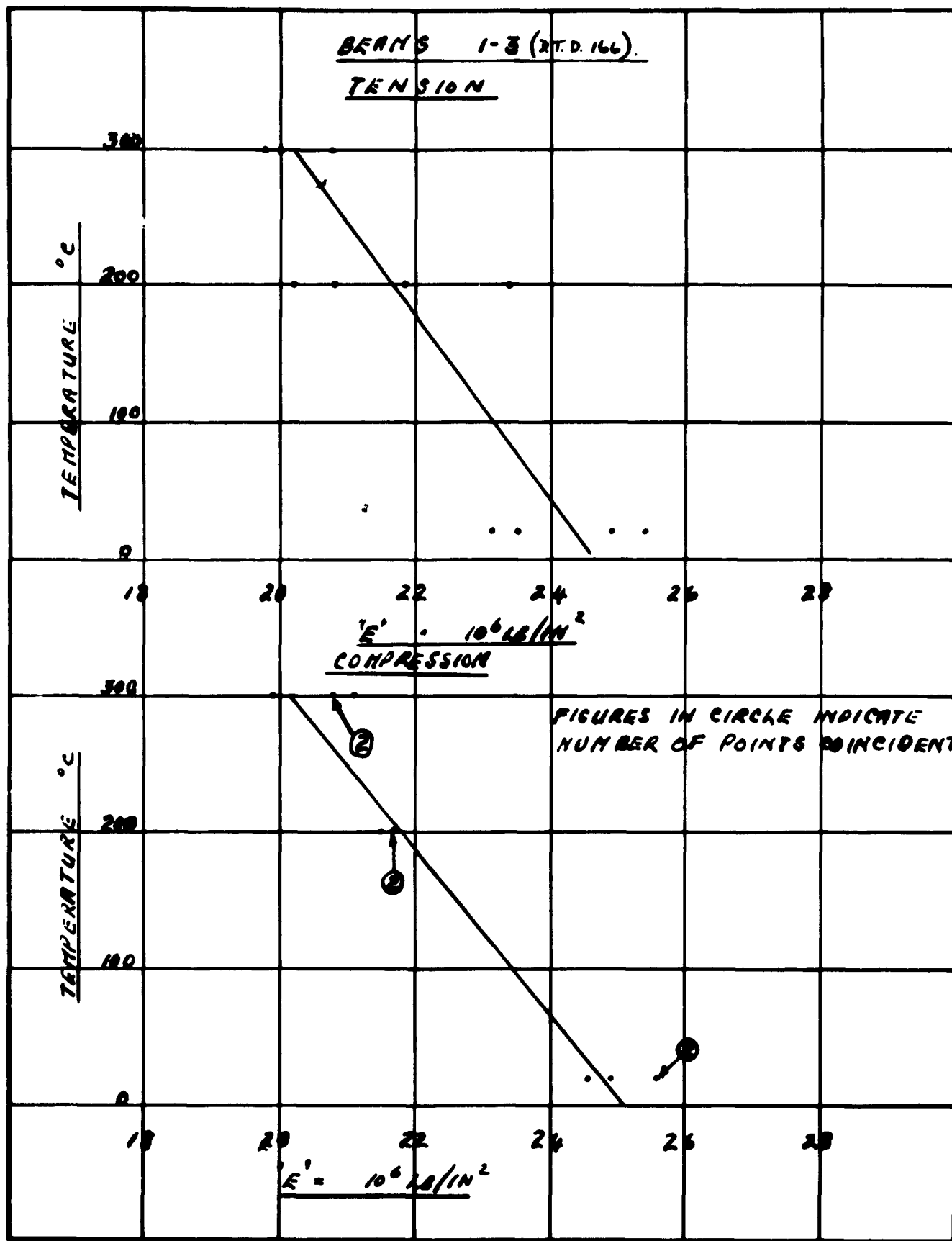

VARIATION OF 'E' WITH TEMPERATURE FIG. 76

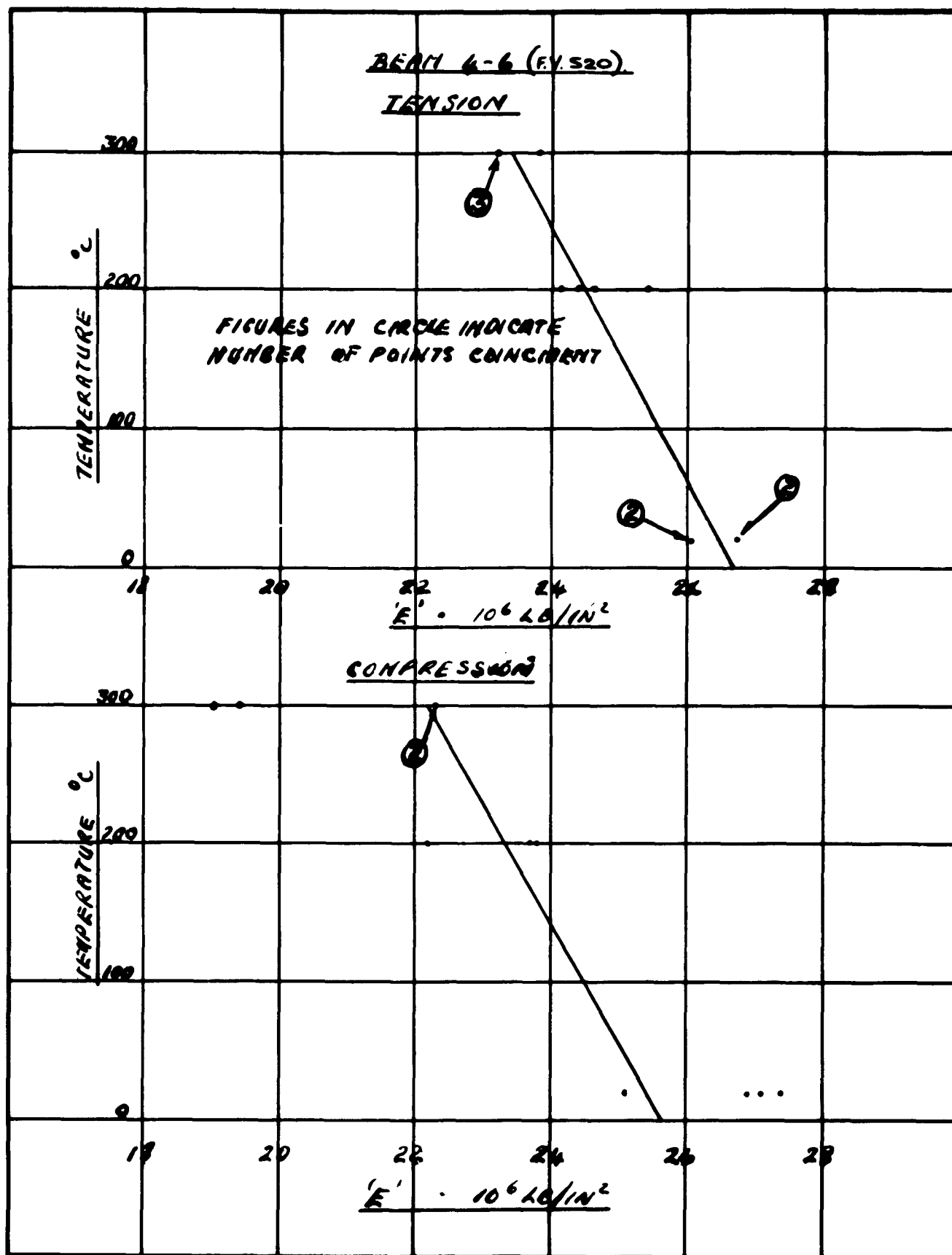

VARIATION OF 'E' WITH TEMPERATURE

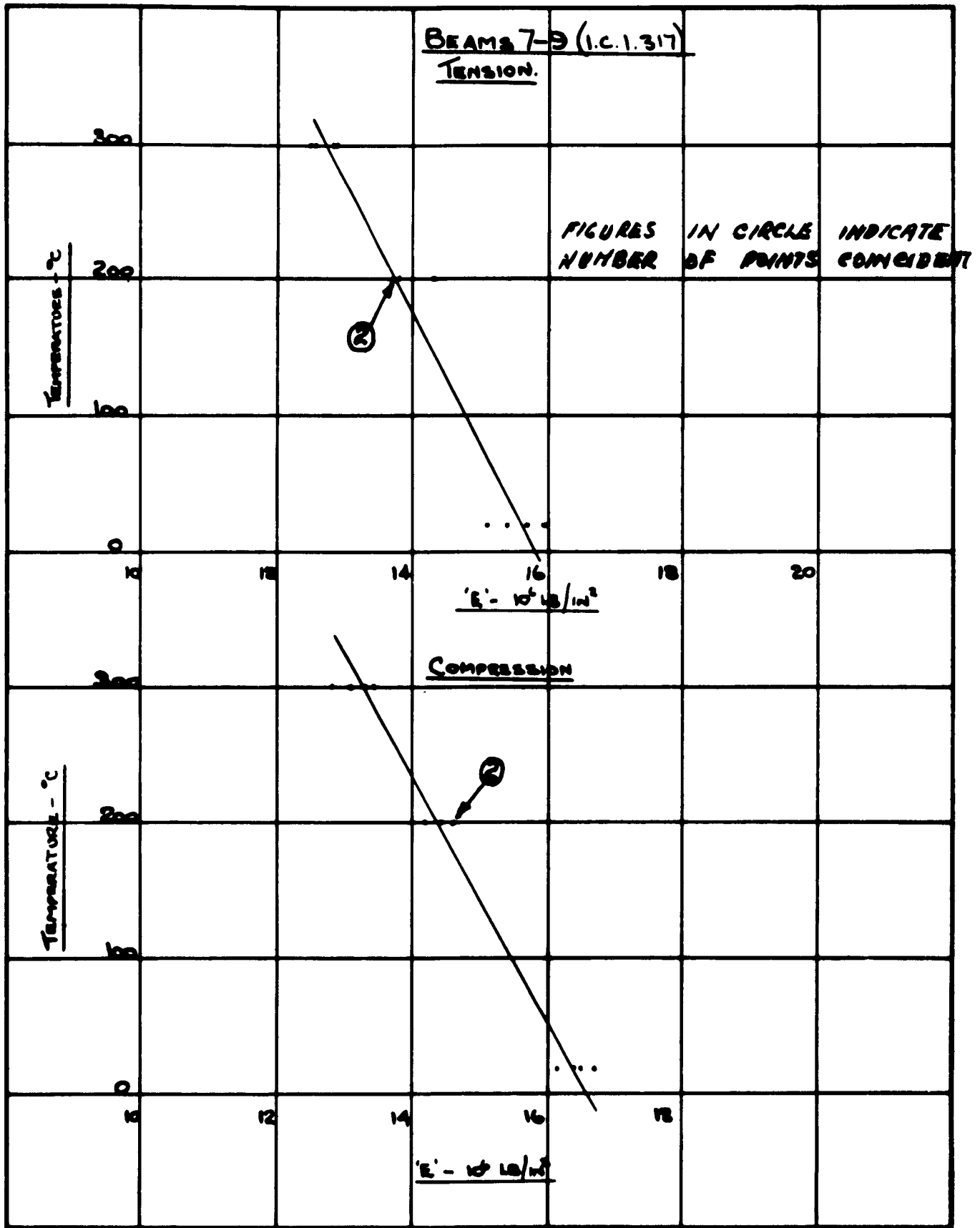

VARIATION OF 'E' WITH TEMPERATURE.

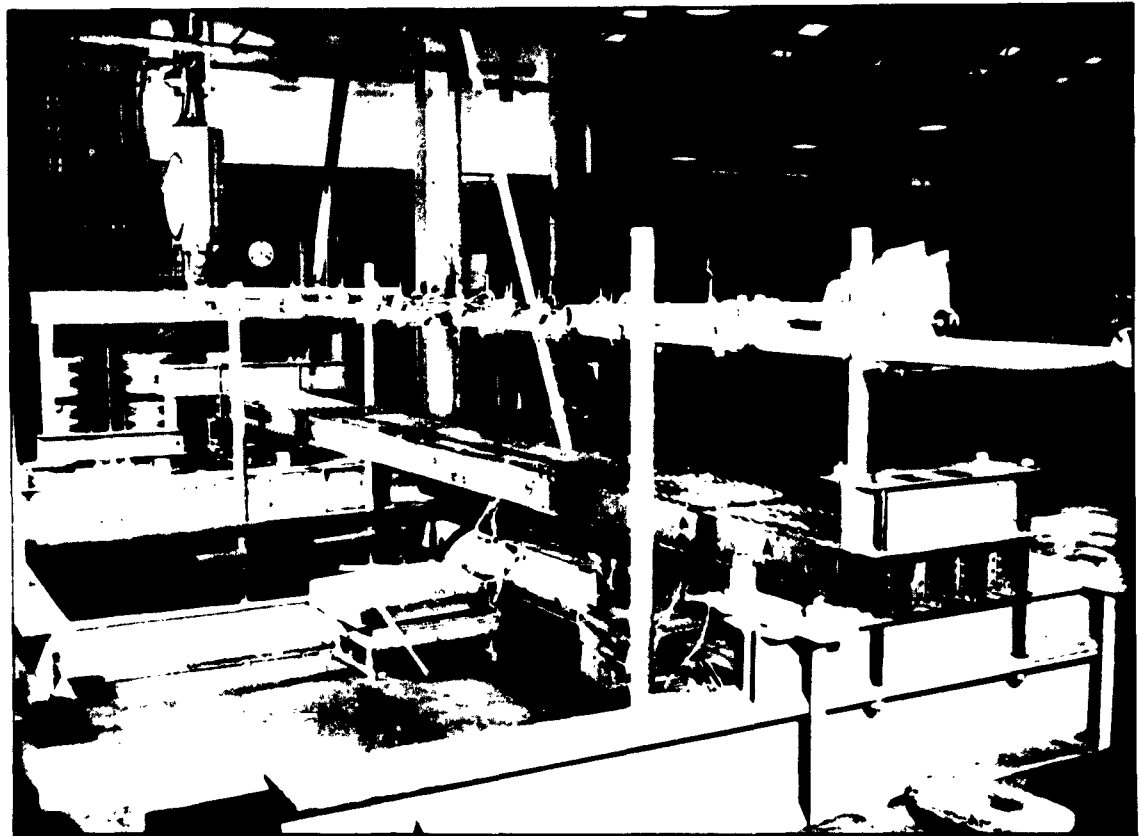

PLATE NO. 1 - TORSION RIG.

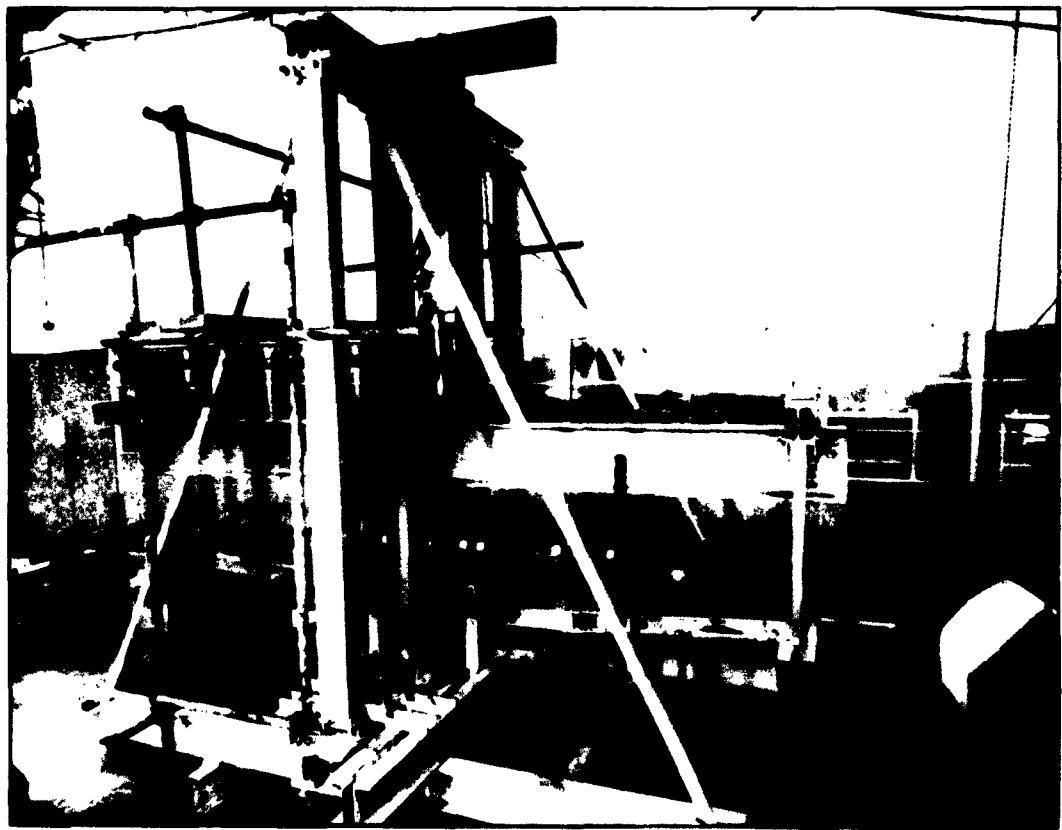

PLATE NO. 2 - BENDING RIG.

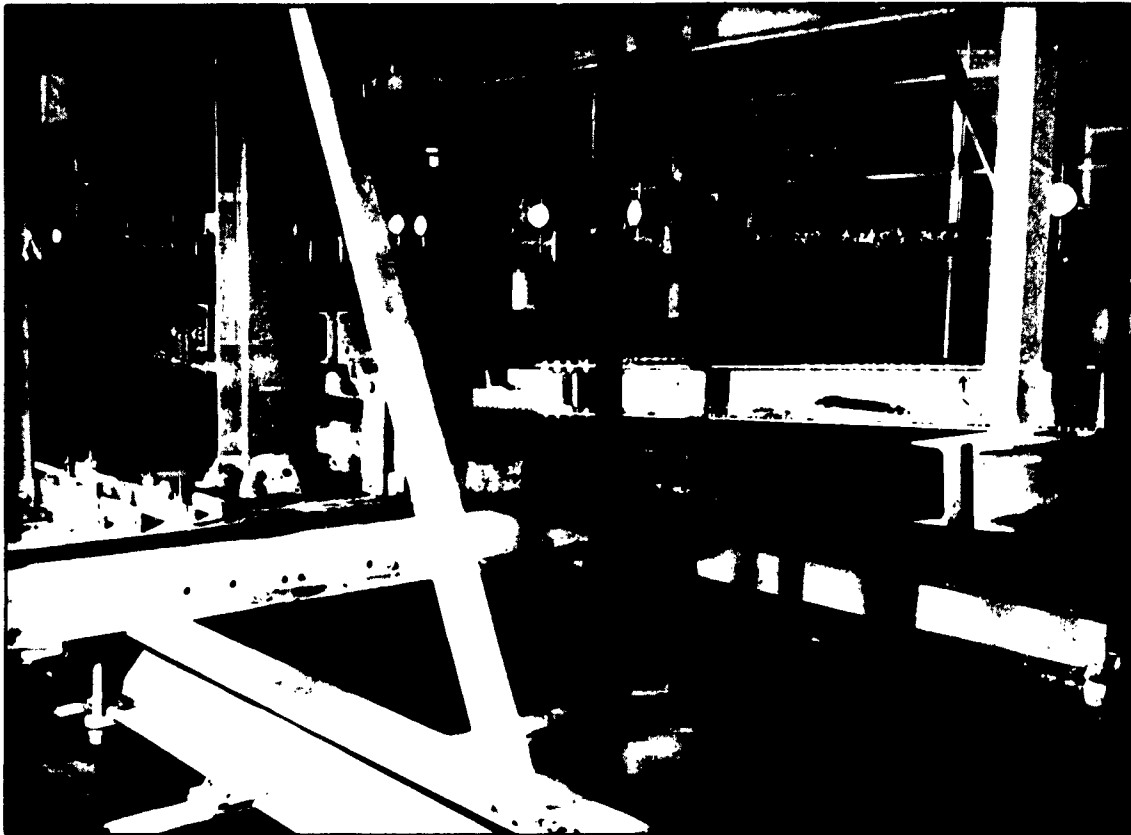

PLATE NO. 5 - BENDING RIG.

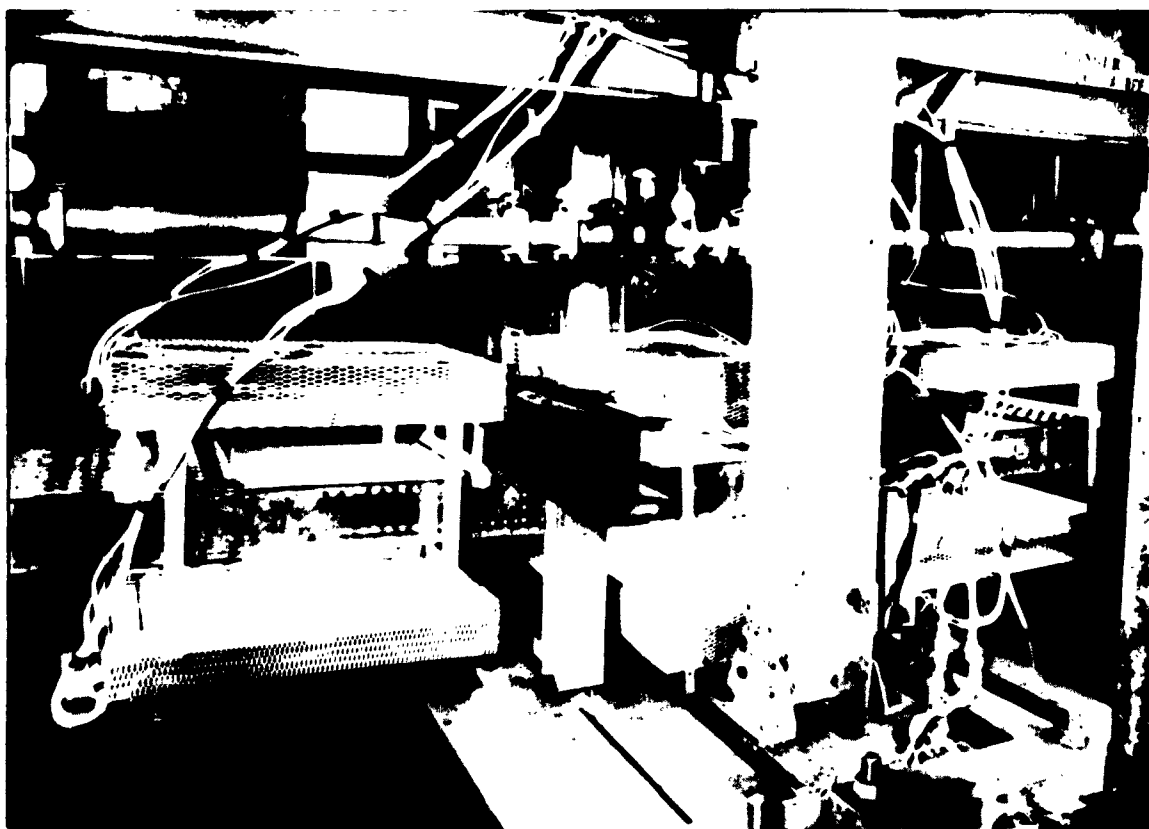

PLATE NO. 4 - LAMP TRAYS.

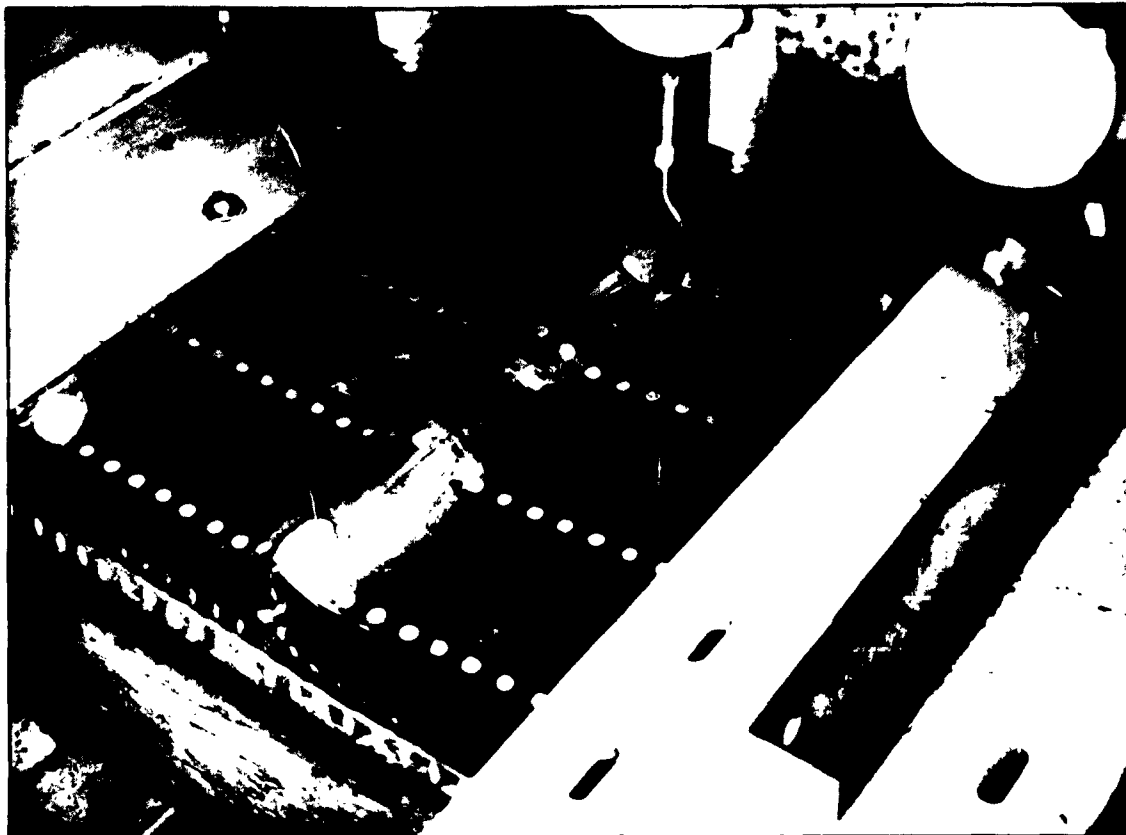

PLATE NO. 5 - BEAM 1 AFTER FAILURE.



PLATE NO. 6 - BEAM 2 AFTER FAILURE.

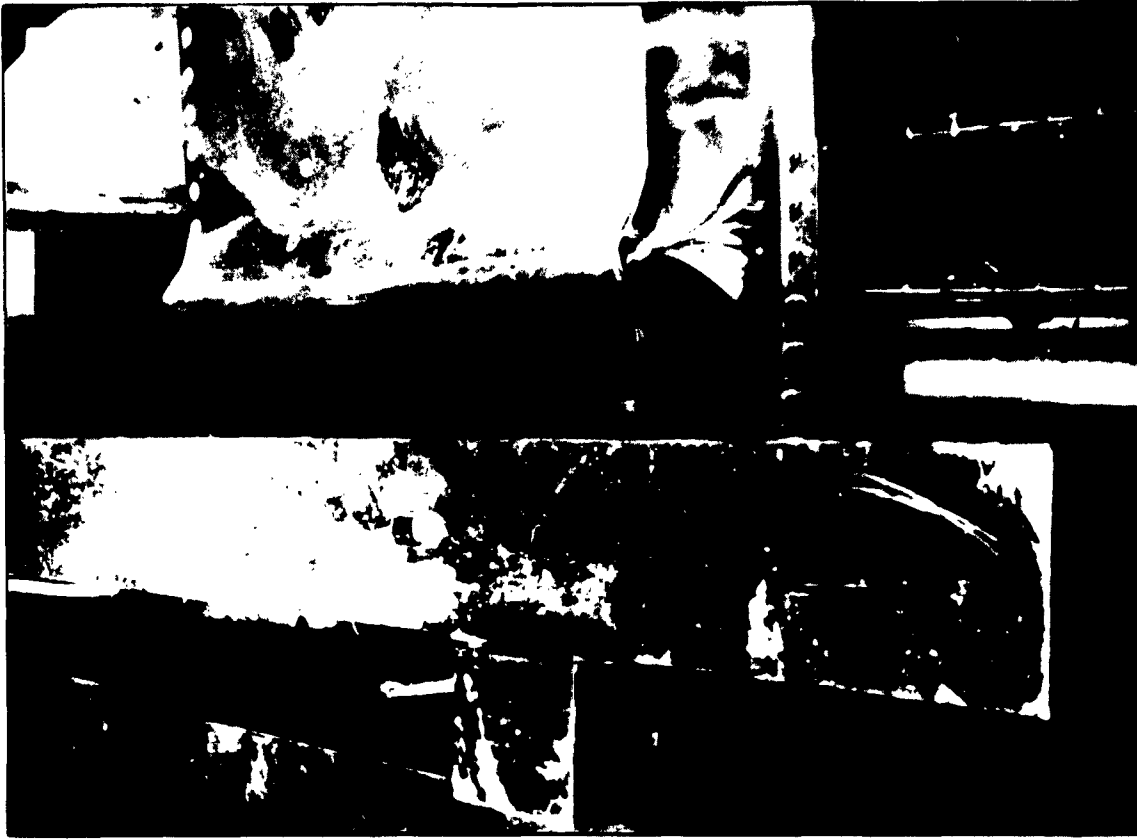

PLATE NO. 7 - BEAM 3 AFTER FAILURE.

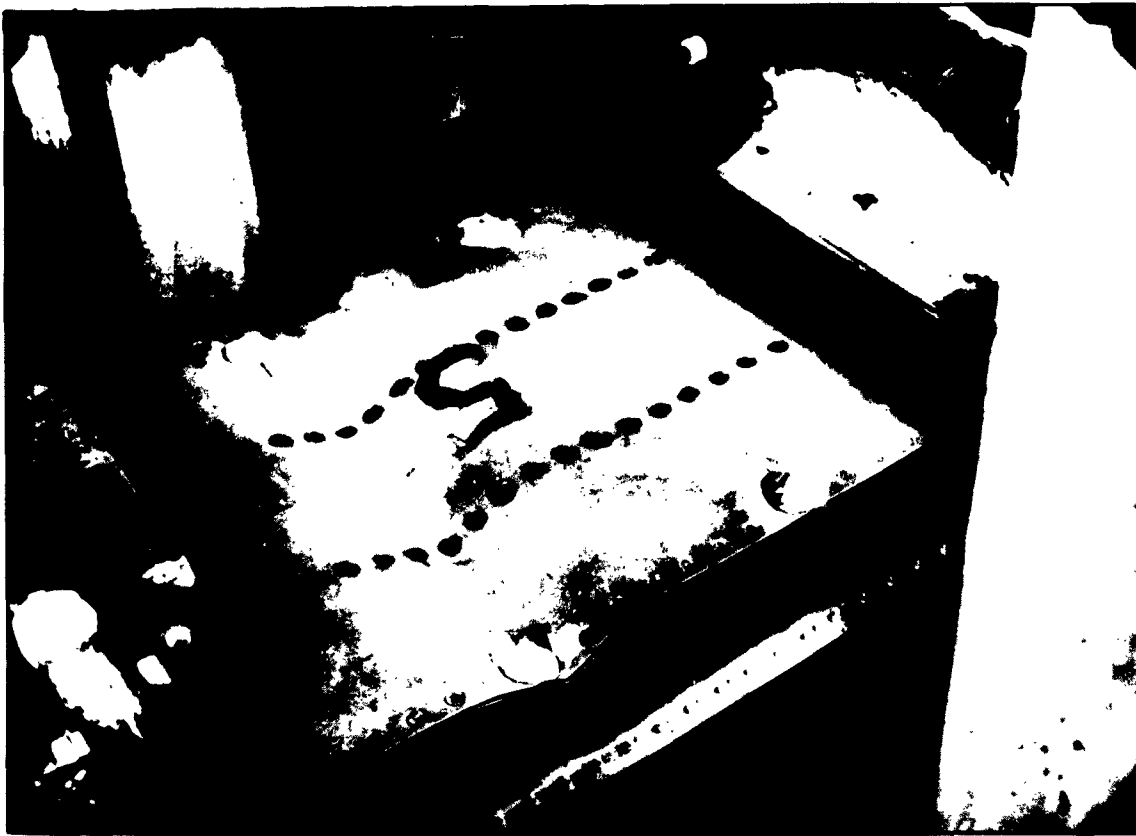

PLATE NO. 8 - BEAM 4 AFTER FAILURE.

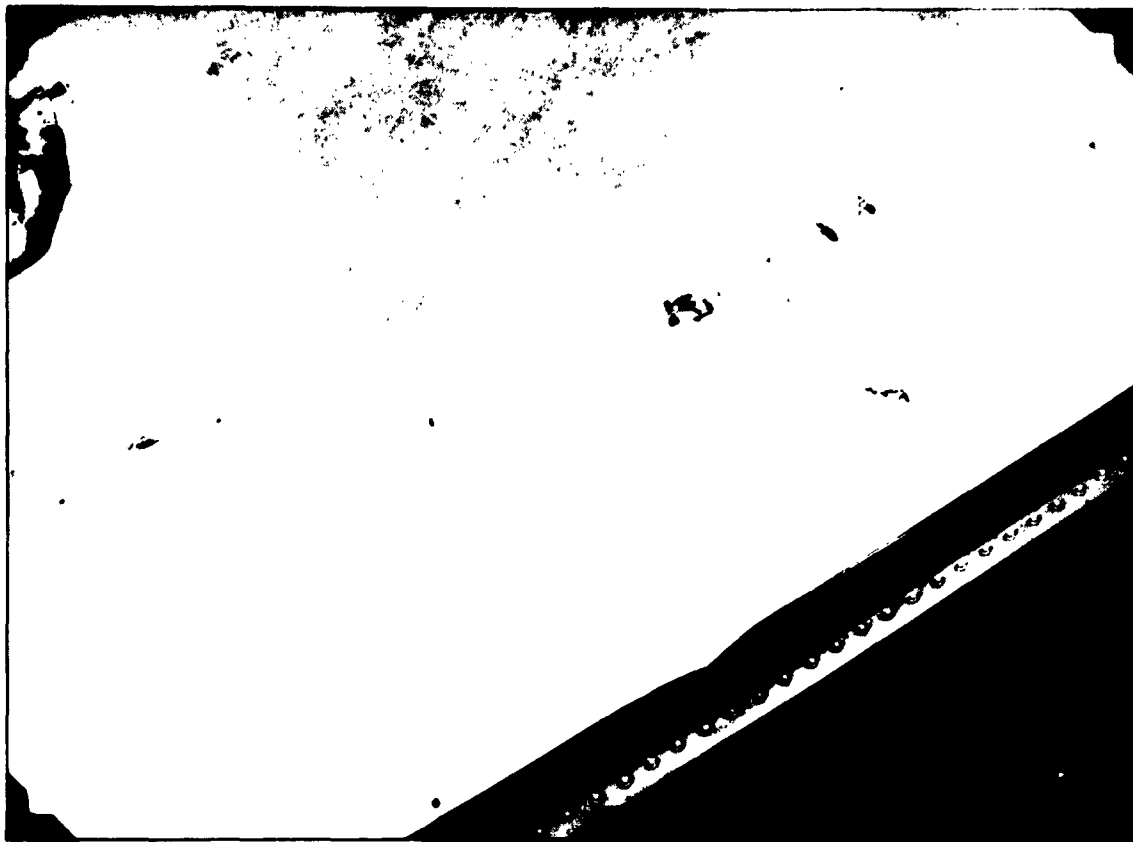

PLATE NO. 9 - BEAM 5 AFTER FAILURE.



PLATE NO. 10 - BEAM 6 AFTER FAILURE.

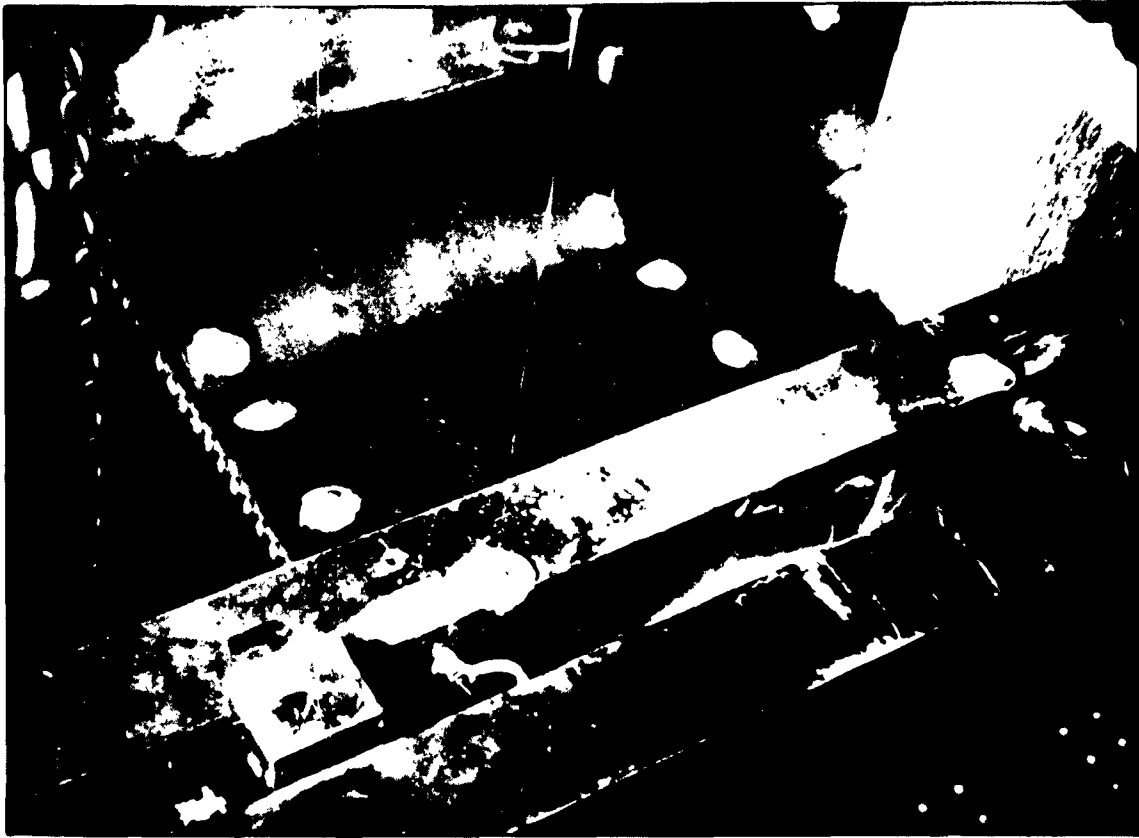

PLATE NO. 11 - BEAM 7 AFTER FAILURE.

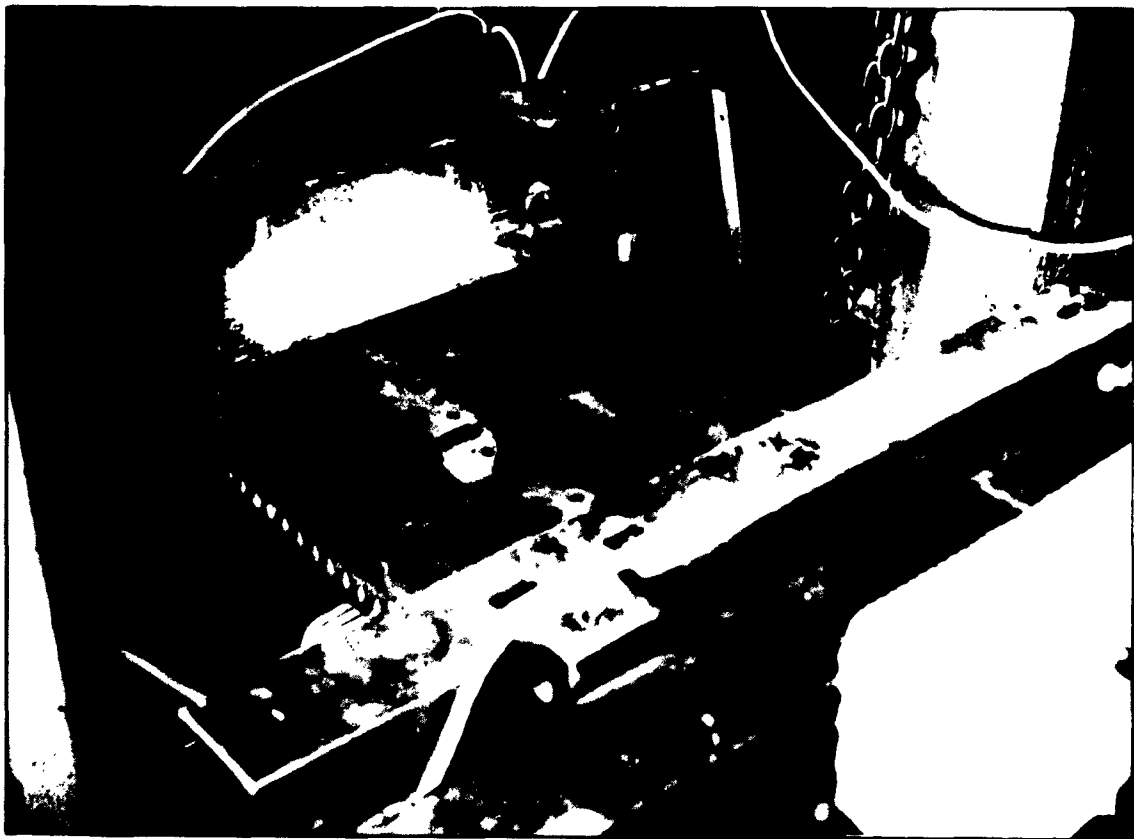

PLATE NO. 12 - BEAM 8 AFTER FAILURE.

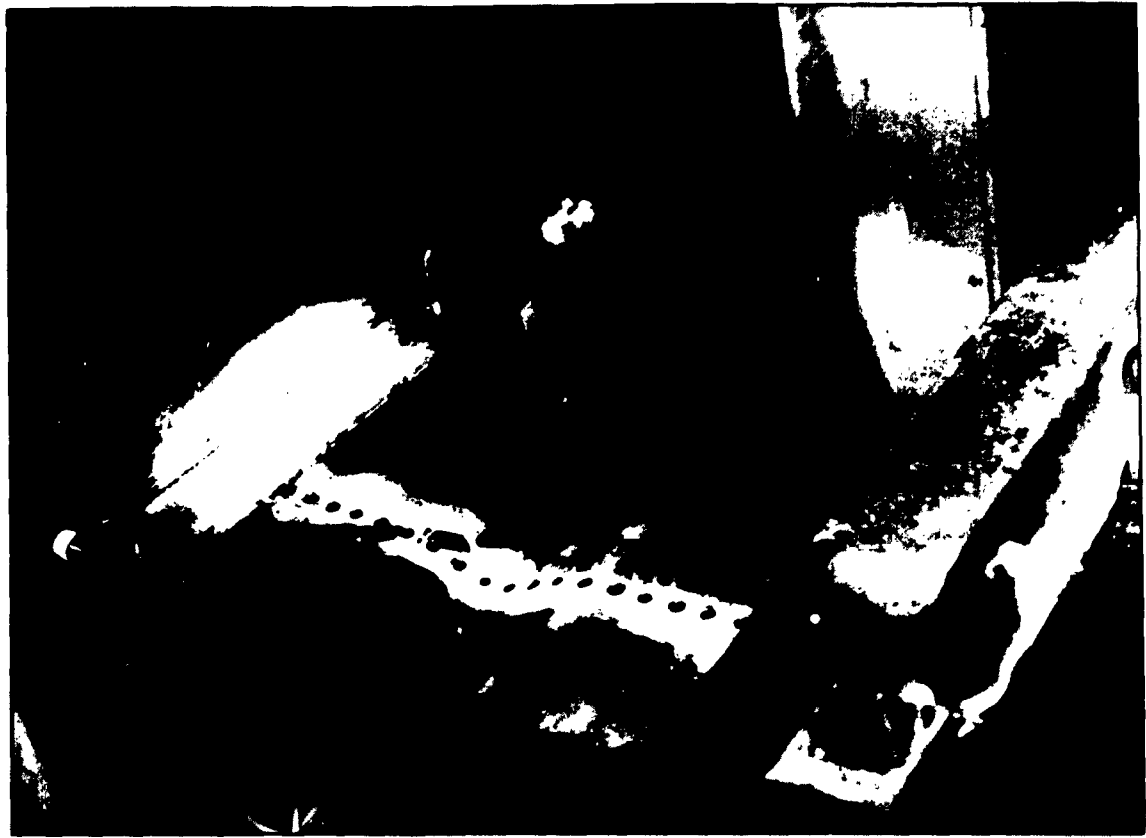

PLATE NO. 13 - BEAM 9 AFTER FAILURE.

PART II.

I N D E X.

Sheet No:

1.	Introduction	1
2.	Theoretical Investigations	1
	2.1. The Prediction of Pure Bending Failure ..	1
	2.2. "Thermal" Stresses	2
	2.3. Torsional Stiffness	2
3.	Comparison between Theory and Experiment	2
	3.1. Bending Strength	2
	3.2. Torsional Stiffness	3
4.	Conclusions	4
5.	References	5

LIST OF TABLES.

1.	Comparison of predicted and experimental failing moments	6
2.	The effects of variation of effective modulus η for the prediction of failing moments by Ref.2	7
3.	Approximate compressive and tensile stresses in the skins and webs due to temperature gradients	8
4.	Comparison of predicted and experimental torsional stiffnesses.	9

LIST OF FIGURES.

1.	Pictorial comparison of experimental and theoretical failing moments.
2.	Pictorial comparison of reduction in beam strength with reduction in material properties.

Strength and Stiffness Tests on Multi-Web Boxes
in Steel and Titanium at elevated temperatures.

Part II - Theoretical Analysis and
Comparison with Experiment.

Part II - THEORETICAL ANALYSIS AND COMPARISON WITH EXPERIMENT1.0 INTRODUCTION.

This report details the results of an investigation into the pure bending strength and torsional stiffness of steel and titanium multi-web beams at ambient and elevated temperatures. This investigation forms a continuation of the earlier research on aluminium alloy multi-web construction reported in Reference 1.

In this part of the present report, the experimental results from Part I are compared with those obtained by the various theoretical methods outlined in Reference 1.

2.0. THEORETICAL INVESTIGATIONS.2.1. The Prediction of Pure Bending Failure.

The methods of analysis described in detail in Reference 1 have been again investigated in full detail for all the present specimens. The methods used in Reference 1 are References 2-5 in paragraph 5.0 of the present report.

The methods were applied exactly as described in Reference 1 using the actual specimen dimensions and plate thicknesses and the material properties at the appropriate elevated temperature as determined from the control test specimens. Several of the methods used an empirical factor for reduction in strength, caused by the use of a discontinuous attachment such as rivets, of web to skin. This reduction factor has been used, where appropriate, in the present analysis but no account has been taken of the reduction in rivet strength at elevated temperature. In the specimens concerned, however, this effect is negligible since the attachment is relatively strong and can be appreciably reduced without a significant effect on the strength of the beam as a whole. If it is assumed that the rivet tension strength varies in proportion to material proof strength the maximum error in the theoretical beam failing moment obtained by ignoring the fall in material strength with rise in temperature is only 1%.

Theoretical beam failing moments obtained as described above are presented in Table 1.

Preliminary comparison of the theory with experiment showed that the agreement was not so good as that reported in Reference 1. It was, therefore, decided to investigate the effect of variation in the assumed

effective modulus to see if this would account for the discrepancy. This investigation was restricted to the method of Reference 2, as this had previously given excellent agreement with experiment and in any case the effect of variation in the assumed effective modulus would be similar for all methods. To cover the widest possible range both tangent and secant modulus were investigated for both skin buckling and skin edge stresses. The results of this variation in choice of effective modulus are shown in Table II.

2.2. "Thermal" Stresses.

It was not possible to obtain an absolutely uniform temperature distribution through both the skins and webs of the specimens. Actual temperature distributions are given in Part I Table A. From those temperatures the average skin and web temperatures given in Table 3 have been calculated for each specimen. Using these average temperatures, average skin compression stresses and web tension stresses have been evaluated by simple theory. These stresses are also given in Table 3. From the temperature measurements obtained it is clearly not possible to obtain a detailed stress distribution giving say, the induced thermal stress at the web to skin junction. However, the stresses, given in Table 3 would not be expected to have an appreciable effect on the bending strength of the specimen.

This conclusion is confirmed by Reference 7 where the strength of the beam in bending was investigated for a large variety of heating rates and therefore thermal stresses. Little change in strength was obtained in the tests in spite of a considerable change in thermal stress. All reduction in strength at elevated temperature was attributed to the reduction in material properties.

2.3. Torsional Stiffness.

Simple Bredt-Batho closed cell torsion theory was the only theory considered. This theory is given in full detail in Reference 6.

A review of other torsion theories was given in Reference 1.

3.0. COMPARISON BETWEEN THEORY AND EXPERIMENT.

3.1. Bending Strength.

The basic theories described in Reference 1 are compared with the experimental results in Table 1 and Figure 1.

Inspection of these results shows that the agreement at ambient temperatures is very good for both Reference 2 methods and reasonable for Reference 3. Reference 4 shows that, as in the case of the aluminium alloy, wrinkling type failures were not predicted. Reference 5 is the approximate design method and here again the agreement between theory and experiment is satisfactory for the purpose.

At elevated temperatures the agreement is not so good, although it is quite satisfactory for both the Firth Vickers 520 and the I.C.I. Titanium Alloy 317. In fact the only result which may be regarded as rather unsatisfactory is for the D1D.166 Stainless Steel at 200°C and to a lesser extent the result at 300°C. This conclusion is highlighted in Figure 1 where the comparison between theory and experiment is pictorial, Figure 2 compares the reduction in beam strength at elevated temperature with the reduction in material properties. This shows that the two experimental results in question seem to be rather high. The further investigations carried out with varying effective modulus for skin buckling and edge stresses, detailed in Table 2, failed to cast any further light on these two results. Although it did show that the slightly better agreement between theory and experiment is obtained if the effective modulus, used in Reference 2, for both skin buckling and edge stresses are taken to be given by the secant modulus. Also, of course, this is by far the easiest modulus to obtain and it can be determined with the greatest accuracy.

The only explanation seems to be that the skin to web joint was rather poorer in the D1D.166 specimen from the heat flow point of view. This would result in a lower flange temperature and consequently higher strength, but temperature measurements show that this is a small effect and could only account for part of the difference between theory and experiment. Inspection of Table 2 shows that the modified theory of Reference 2, as explained in Reference 1, together with the use of secant effective modulus gives a scatter of +5% to -15% of theory relative to experiment. This scatter is considered reasonable when two separate effects (loading and temperature) are combined in one test.

3.2. Torsional stiffness

Theoretical and experimental torsional stiffnesses (GJ) are compared in Table 4. Theory compares very well with experiment, the scatter band covering the range +11% to -3%. Thus the theory is, on the average, some 4% higher than experiment with an accuracy on this basis of ±7%. The fact that the theory is higher than experiment is expected since the theory includes no allowance for rivet slip. It should be noted that the theoretical stiffness uses a modulus of rigidity obtain by material control tests given in Table K, sheet 21 of Part I (the L.B. value is appropriate in this case). Since these values correspond to

room temperature conditions the values for elevated temperature conditions have been obtained by reducing these values in proportion to the reduction in modulus of elasticity report in Table E, sheet 14, of Part I.

It is interesting to note that the ratio of modulus of rigidity to material density is 33.3×10^6 for the titanium alloy compared with 36.7×10^6 for both the stainless steels, i.e. the titanium alloy is some 8% less rigid than the stainless steel. In addition, the test results on the box beams show a further average reduction in stiffness of the titanium alloy specimen of some 8% in relation to the stainless steel boxes. Thus, in an application where torsional stiffness of a box is the design criterion the titanium alloy box will be some 16% heavier than the corresponding stainless steel box.

4.0 CONCLUSIONS

The conclusion of Reference 1, that there is good agreement between bending theory, particularly that of Reference 2, and experiment has been verified for the stainless steel and titanium alloy multi-web beam investigated in this report. It should be noted, however, that there is considerably more "scatter" of the theory relative to experiment at elevated temperature. This scatter is slightly reduced, and more important the computation work associated with the theory considerably reduced, if the effective modulus factor is taken to be the ratio of the secant and Young's Modulus instead of the more complex Stowell theory normally used.

The torsional stiffness tests show that the theory, on average, predicts torsional stiffnesses some 4% greater than experiment. This increase is directly attributable to the slip of the rivetted attachment of the skins to the webs. If, an allowance of 4% is made for this effect the theory may be expected to be within $\pm 7\%$ of experiment.

10. REFERENCES.

1. R. L. Wheeler Multi-web construction research.
(Aluminium Alloy) Part II) Theoretical Analysis
S & T Memo 1/61.
2. R. L. Wheeler Bending Strength of skin-stringer combinations
T. H. Wilkinson under Lateral Pressure.
Saunders-Roe Report No: Structure/Gen/36.
3. R. A. Needham The ultimate strength of Multi-web Box Beams
in pure bending.
Journal of the Aeronautical Sciences.
November 1955 (Vol. 22 No: 11)
4. J. W. Semorian An analysis of the stability and ultimate
R. A. Anderson bending strength of Multi-web Beams with
Formed-Channel Webs.
N.A.C.A. Technical Note : 3232
5. R. Tatham The prediction of buckling and ultimate
R. L. Wheeler stress for Multi-web Boxes subjected to
pure bending.
Saunders-Roe Report No: Structure/Gen/10.
6. R. A. Pride An investigation of the effects of rapid skin
heating on Box Beams loaded in pure bending.
N.A.C.A. RM/L55B03 March 1955.
7. E. E. Mathauser Investigation of static strength and creep
behaviour of aluminium alloy Multi-web Box
Beam at elevated temperature.
N.A.C.A. TN.3310

TABLE 1.
COMPARISON OF PREDICTED AND EXPERIMENTAL FAILING MOMENTS.

Specimen No : (Ref. Pt. 1 Sheet 1)	Material	Test Temp °C	Predicted Failing Moment [#] (lb.in.)					Exp. Failing Moment (from Pt. 1 Table M) (lb.in.)	Ratio of Predicted B.M. to Experimental B.M.				
			1	2	3	4	5		1	2	3	4	5
			1	DTD 166	Ambient	412,500	408,000		457,000	543,000	425,000	1.007	0.995
2	"	200	320,600	326,000	378,000	434,000	340,000	0.802	0.815	0.946	1.085	0.850	
3	"	300	338,000	349,000	384,000	441,000	349,000	0.833	0.860	0.946	1.086	0.860	
4	Pirith Victors 520	Ambient	438,000	436,000	490,000	563,000	459,000	1.042	1.038	0.946	1.34	1.092	
5	"	200	382,000	380,000	423,000	480,000	398,000	1.061	1.055	1.166	1.332	1.108	
6	"	300	375,000	377,000	427,000	475,000	387,500	1.033	1.039	1.177	1.308	1.067	
7	Zibendum Alloy IC1317	Ambient	520,000	500,000	531,000	623,000	546,000	1.023	0.985	1.177	1.225	1.074	
8	"	200	376,000	391,000	447,000	558,000	416,000	0.862	0.899	1.046	1.260	0.955	
9	"	300	368,000	378,000	414,000	545,000	401,000	0.995	1.022	1.025	1.472	1.08	

1. Based on the method of Ref. 2
 2. " " " " " " (modified as described in Ref. 1 para. 2.2)
 3. " " " " " " 3
 4. " " " " " " 4
 5. " " " " " " 5

TABLE 3.

APPROXIMATE COMPRESSIVE AND TENSILE STRESSES
 IN THE SKINS AND WEBS DUE TO TEMPERATURE GRADIENTS.

Specimen No: (Ref.Pt.1 Sheet 1)	Material	Average Temp.of skin °C	Average Temp.of webs °C	Compressive Stress in skin (lb./in. ²)	Tensile Stress in web (lb./in. ²)
2	DTD.166	200	150	3,690	14,570
3	"	300	240	4,090	16,630
5	Firth Vickers 520	200	160	2,400	9,500
6	"	280	220	3,450	14,200
8	Titanium Alloy ICI 317	200	150	1,295	5,150
9	"	290	225	1,670	6,120

TABLE 4.

COMPARISON OF PREDICTED AND EXPERIMENTAL
 TORSIONAL STIFFNESS

Specimen No: (Ref.Pt.1 Sheet 1)	Material	Test Temp. °C.	Predicted G.J.* (lb.in/rad./in)	Experimental G.J. (from Table E) (lb.in/rad./in)	Predicted Experiment [†]
1	DTD.166	Ambient	234 x 10 ⁶	224 x 10 ⁶	1.045
2	"	200	193 x 10 ⁶	198 x 10 ⁶	0.975
3	"	300	199 x 10 ⁶	192 x 10 ⁶	1.034
4	Firth Vickers 520	Ambient	233 x 10 ⁶	233 x 10 ⁶	1.000
5	"	200	210 x 10 ⁶	212 x 10 ⁶	0.990
6	"	300	207 x 10 ⁶	202 x 10 ⁶	1.025
7	Titanium Alloy ICI.317	Ambient	150 x 10 ⁶	139 x 10 ⁶	1.077
8	"	200	133 x 10 ⁶	126 x 10 ⁶	1.056
9	"	300	125 x 10 ⁶	112 x 10 ⁶	1.115

* The value of G used in the predicted stiffness is that given in Table K, sheet 21, of Part I and corresponds to the LB value. Since these are only room temperature values they were reduced at elevated temperature in proportion to the reduction in Young's Modulus of elasticity given in Table E, sheet 14, of Part I.

FIG. 1.

FAILING MOMENT AS A PERCENTAGE OF THE ROOM
TEMPERATURE EXPERIMENTAL FAILING MOMENT.

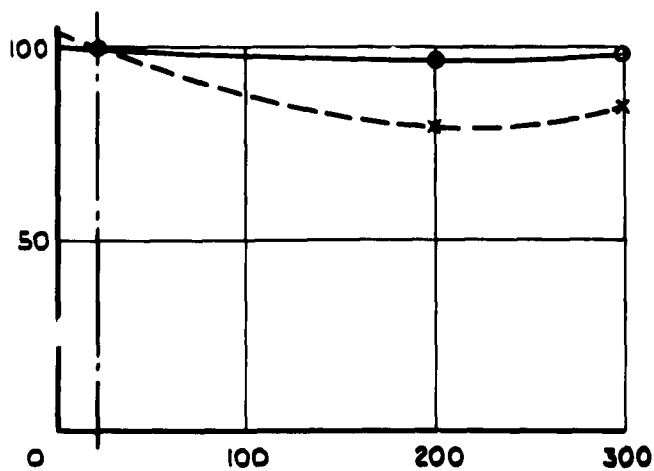

STAINLESS STEEL
(D.T.D. 166)

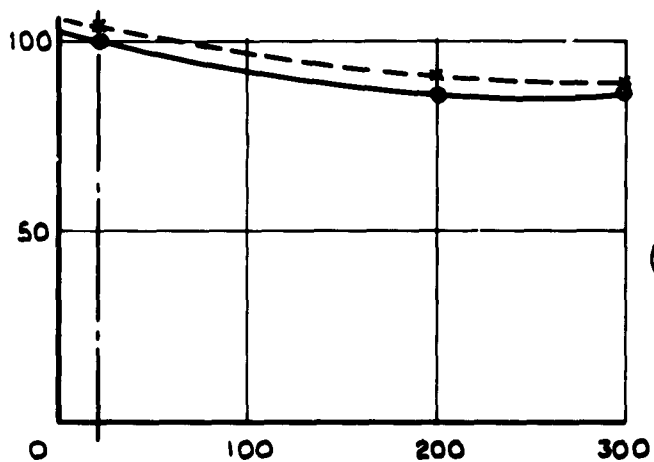

STAINLESS STEEL
(FIRTH VICKERS 520)

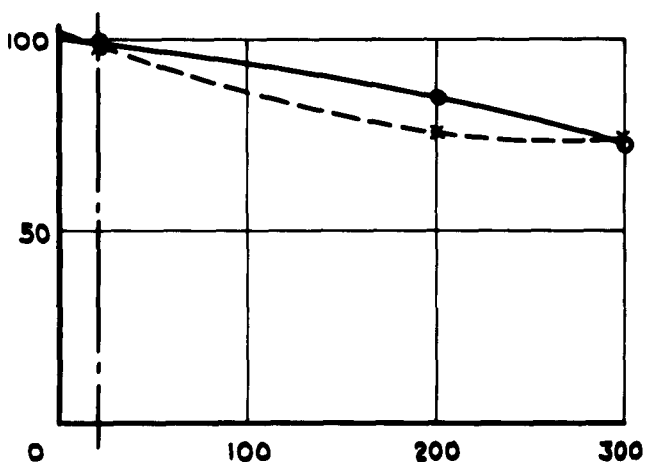

TITANIUM ALLOY
(I.C.I. 317)

KEY

— EXPERIMENTAL F.M.

--- PREDICTED (FROM MODIFIED REF. 2.)

PICTORIAL COMPARISON OF EXPERIMENTAL AND
THEORETICAL FAILING MOMENTS

FIG. 2.

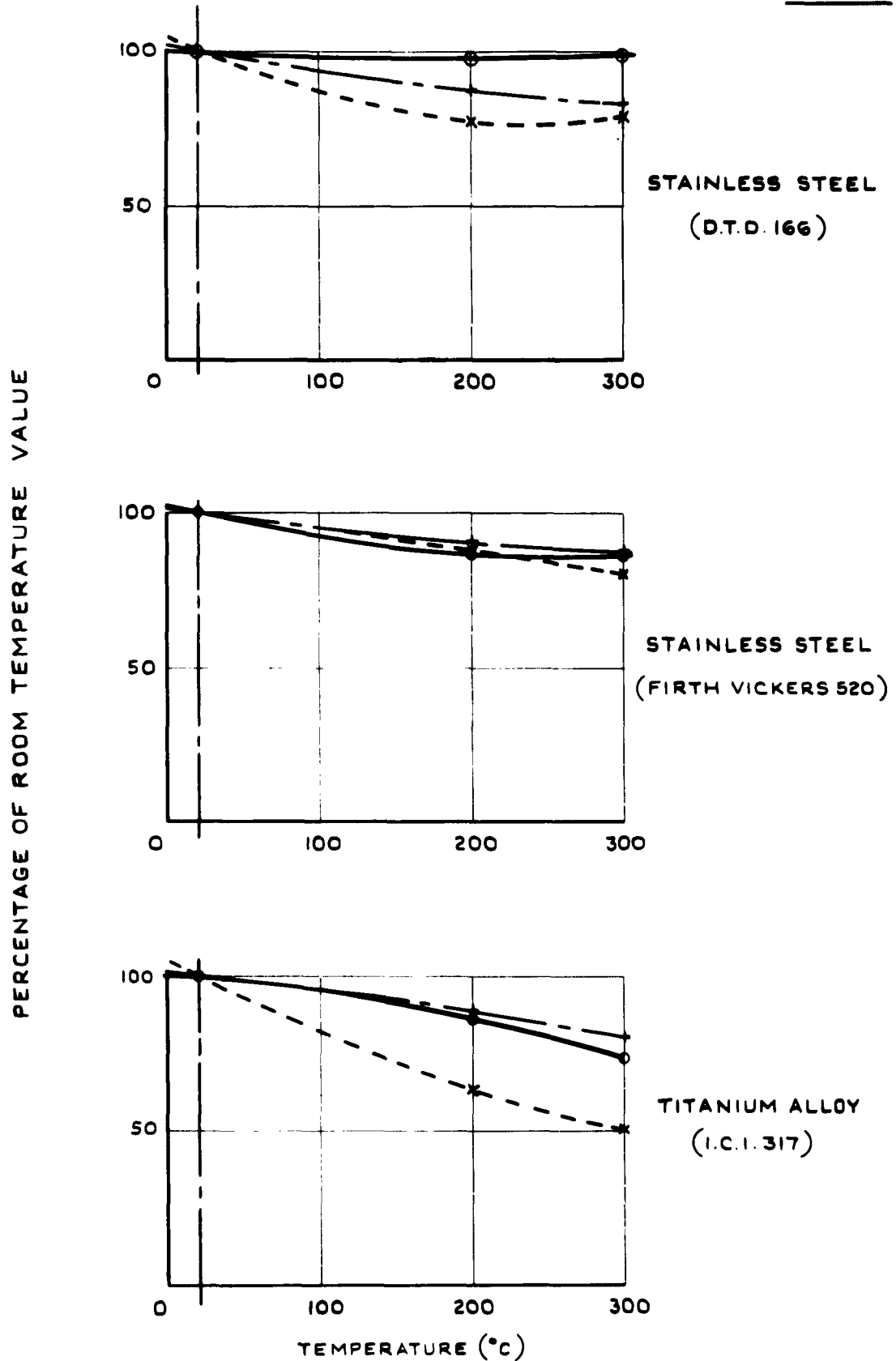

- KEY
- EXPERIMENTAL FM OF BOX BEAM
 - - - 2% PROOF STRESS OF MATERIAL
 - · - · MODULUS OF ELASTICITY OF MATERIAL

PICTORIAL COMPARISON OF REDUCTION IN BEAM
STRENGTH WITH REDUCTION IN MATERIAL PROPERTIES



*Information Centre
Knowledge Services*
[dstl] Porton Down
Salisbury
Wilts
SP4 0JQ
22060-6218
Tel: 01980-613753
Fax 01980-613970

Defense Technical Information Center (DTIC)
8725 John J. Kingman Road, Suit 0944
Fort Belvoir, VA 22060-6218
U.S.A.

AD#: AD280189

Date of Search: 13 August 2008

Record Summary: AVIA 10/536

Title: Strength and stiffness tests on multi-web boxes in steel and titanium at elevated temperatures

Availability Open Document, Open Description, Normal Closure before FOI Act: 30 years

Former reference (Department) 3/61

Held by The National Archives, Kew

This document is now available at the National Archives, Kew, Surrey, United Kingdom.

DTIC has checked the National Archives Catalogue website (<http://www.nationalarchives.gov.uk>) and found the document is available and releasable to the public.

Access to UK public records is governed by statute, namely the Public Records Act, 1958, and the Public Records Act, 1967.

The document has been released under the 30 year rule.

(The vast majority of records selected for permanent preservation are made available to the public when they are 30 years old. This is commonly referred to as the 30 year rule and was established by the Public Records Act of 1967).

This document may be treated as UNLIMITED.