

**UNCLASSIFIED**

---

---

**AD 283 754**

*Reproduced  
by the*

**ARMED SERVICES TECHNICAL INFORMATION AGENCY  
ARLINGTON HALL STATION  
ARLINGTON 12, VIRGINIA**



---

---

**UNCLASSIFIED**

**NOTICE:** When government or other drawings, specifications or other data are used for any purpose other than in connection with a definitely related government procurement operation, the U. S. Government thereby incurs no responsibility, nor any obligation whatsoever; and the fact that the Government may have formulated, furnished, or in any way supplied the said drawings, specifications, or other data is not to be regarded by implication or otherwise as in any manner licensing the holder or any other person or corporation, or conveying any rights or permission to manufacture, use or sell any patented invention that may in any way be related thereto.

283 754

62-4-6

**U. S. A R M Y**  
**TRANSPORTATION RESEARCH COMMAND**  
**FORT EUSTIS, VIRGINIA**

CATALOGED BY ASTIA  
AS AD NO. 283 754

TCREC Technical Report 62-25

**FLEXIBLE-WING MANNED TEST VEHICLE**

Task 9R38-01-017-72

Contract DA44-177-TC-721

August 1962

PREPARED BY

RYAN AERONAUTICAL COMPANY  
San Diego, California

ASTIA  
RECEIVED  
SEP 14 1962  
ASTIA Q



## NOTICES

### DISCLAIMER NOTICE

1. When Government drawings, specifications, or other data are used for any purpose other than in connection with a definitely related Government procurement operation, the United States Government thereby incurs no responsibility nor any obligation whatsoever; and the fact that the Government may have formulated, furnished, or in any way supplied the said drawings, specifications, or other data is not to be regarded by implication or otherwise as in any manner licensing the holder or any other person or corporation, or conveying any rights or permission, to manufacture, use, or sell any patented invention that may in any way be related thereto.

### ASTIA AVAILABILITY NOTICE

3. Qualified requesters may obtain copies of this report from  
Armed Services Technical Information Agency  
Arlington Hall Station  
Arlington 12, Virginia
8. This report has been released to the Office of Technical Services, U. S. Department of Commerce, Washington 25, D. C., for sale to the general public.
10. The information contained herein will not be used for advertising purposes.
12. The findings and recommendations contained in this report are those of the contractor and do not necessarily reflect the views of the Chief of Transportation or the Department of the Army.

**HEADQUARTERS  
U. S. ARMY TRANSPORTATION RESEARCH COMMAND  
Fort Eustis, Virginia**

In this report Ryan Aeronautical Company documents the fabrication, the flight testing, and the modifications to the flexible-wing manned test vehicle during 25 hours of flight testing at San Diego, California. The U. S. Army Transportation Research Command concurs in the conclusions and recommendations contained in the report.

A follow-up program based on the contractor's findings was conducted at the full-scale wind-tunnel facility at the NASA Langley Research Center. The flight-test data were corroborated, and the program has been completed.

The results of the wind-tunnel tests will be published soon under NASA TM SX-727 and can then be obtained from the NASA Office of Scientific and Technical Information, Washington, D. C.

FOR THE COMMANDER:

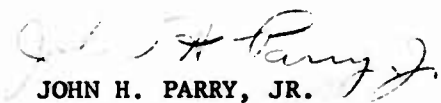
  
JOHN H. PARRY, JR.  
1st Lt., TC  
Adjutant

APPROVED BY:

  
E. ROUZÉE GIVENS  
USATRECOM Project Engineer

**Project 9R 38-01-017-72  
Contract DA 44-177-TC-721  
February 1961**

**FLEXIBLE-WING MANNED TEST VEHICLE**

**Ryan Report 61B131A  
25 June, 1962**

**Prepared by  
Ryan Aeronautical Company  
San Diego, California**

**for  
U. S. ARMY TRANSPORTATION RESEARCH COMMAND  
FORT EUSTIS, VIRGINIA**

## CONTENTS

	PAGE
1.0 TRECOM COMMAND POSITION STATEMENT	1-1
2.0 FOREWORD	2-1
3.0 LIST OF ILLUSTRATIONS	3-1
4.0 SUMMARY	4-1
5.0 CONCLUSIONS	5-1
6.0 RECOMMENDATIONS	6-1
7.0 DESCRIPTION OF TEST BED	7-1
8.0 WEIGHT DATA	8-1
9.0 DESIGN CRITERIA AND STRESS ANALYSIS	9-1
10.0 INSTRUMENTATION	10-1
11.0 FLIGHT TESTS	11-1
12.0 BIBLIOGRAPHY	12-1
13.0 APPENDIX	13-1
14.0 DISTRIBUTION	14-1

## 2.0 FOREWORD

The flight test program covered by this report was conducted by Ryan Aeronautical Company in support of the U. S. Army's Paraglider Concept Study. The program was conducted under the provisions of Contract DA 44-177-TC-721 between the U. S. Army Transportation Research Command and the Ryan Aeronautical Company. Mr. C. E. Craigo of Ryan was project manager and Messrs. E. R. Givens and J. E. Forehand of the Aviation Directorate served as project engineers for TRECOM.

Initial phases of the concept study had been conducted on wind tunnel and radio controlled models by the Langley Research Center, NASA. Aerodynamic stability and control data obtained from flight tests of a full-sized Flexible Wing manned vehicle were desired. Such a vehicle had been fabricated by Ryan, and safety, flight, and functional tests had been conducted prior to the commencement of the Government sponsored test program.

All testing was conducted at the U. S. Navy's Brown Field installation near San Diego, California, beginning 22 June 1961 and ending 15 November 1961.

The splendid cooperation of Commander George H. Doolittle, USN, Commanding Officer of Brown Field, and the men of his command, who provided hangar space, emergency equipment, and traffic control during the test period, contributed greatly to the satisfactory completion of the test operations.

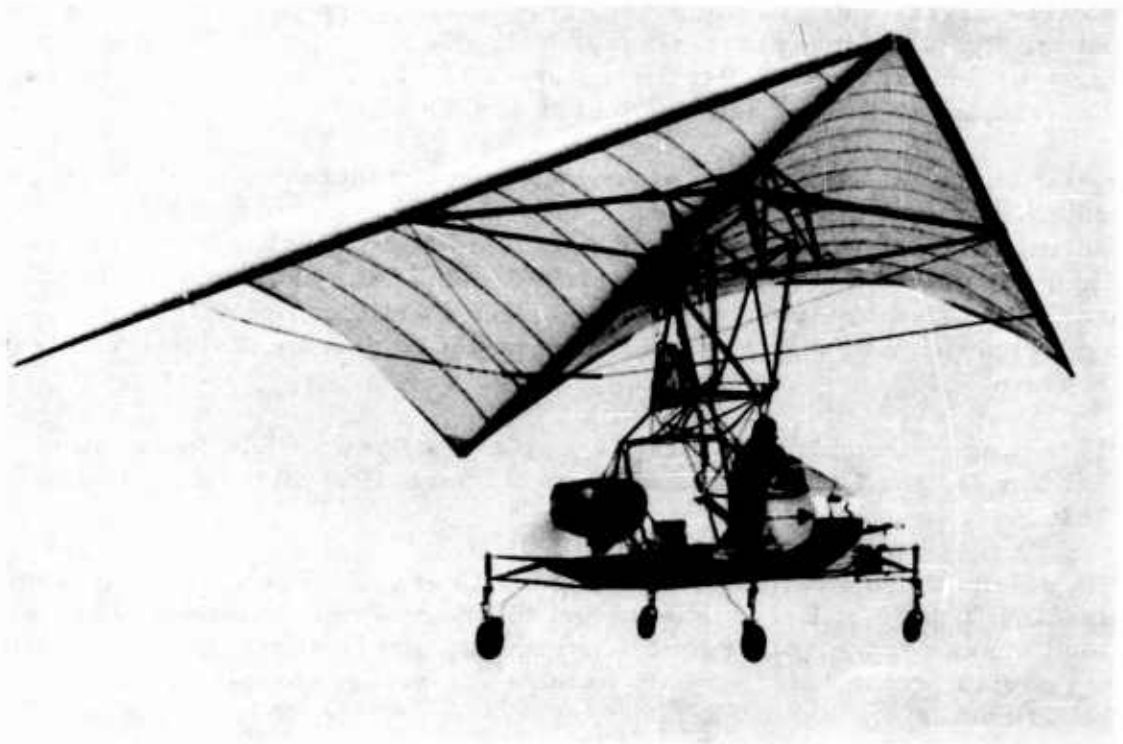

**Figure 2.1 Test Bed with Continental Engine in Flight**

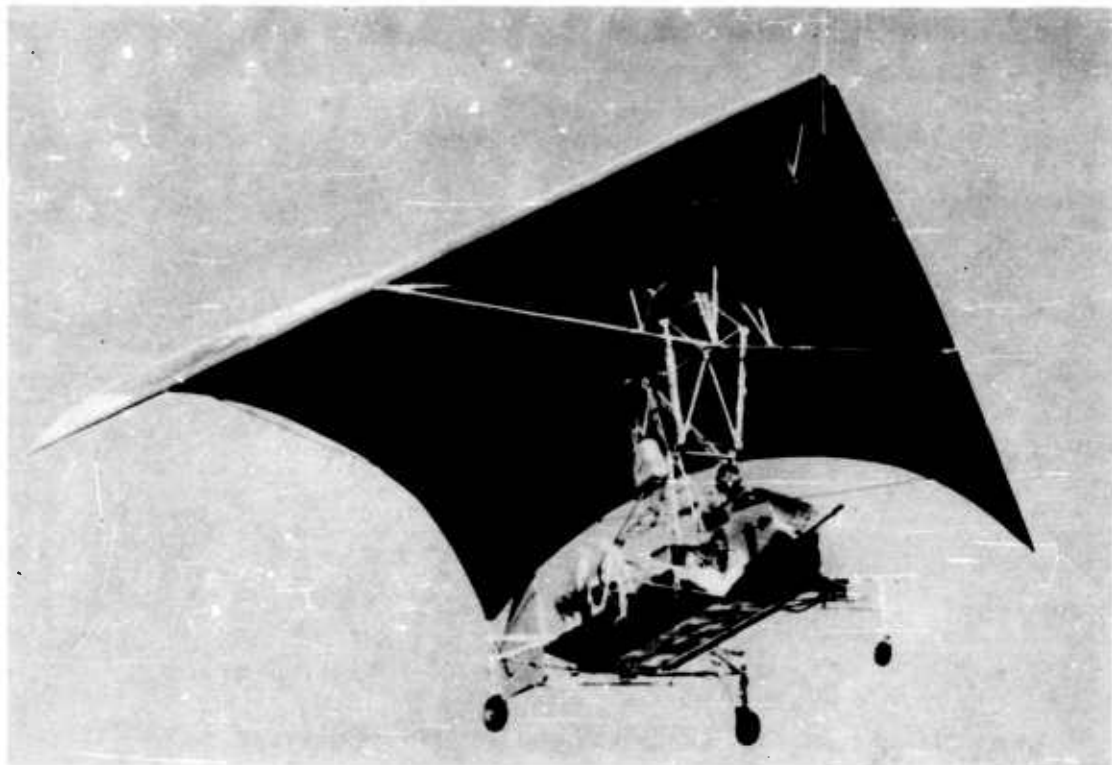

**Figure 2.2 Test Bed with Lycoming Engine in Flight**

### 3.0 LIST OF ILLUSTRATIONS

<u>Figure No.</u>		<u>Page</u>
2.1	Test Bed with Continental Engine in Flight	2-2
2.2	Test Bed with Lycoming Engine in Flight	2-3
7.1	General Arrangement (Original)	7-7
7.2	General Arrangement ("A" Change)	7-9
7.3	Flat Plan Geometry of Wing Scallop, Battens and Fabric Orientation	7-11
8.1	Table of Actual Weights	8-2
8.2	Table of Gross Weight and C.G. Locations	8-4
9.1	Design Conditions and Load Factors	9-1
9.2	Distribution of Loads to Wing Structure	9-2
9.3	Shear Distributions	9-2
9.4	Bending Moments Distributions	9-2
9.5	V-n <sub>z</sub> Diagram	9-3
9.6	Comparison of Calculated Axial and Shear Loads and Bending Moments	9-10
10.1	History of Oscillograph Instrumentation	10-5
10.2	Instrumentation Layout	10-6
10.3	Typical Potentiometer Circuit	10-7
10.4	Potentiometer Circuit Sensitivity Chart	10-8
10.5	Typical Strain Gage Circuit	10-9
10.6	Strain Gage Circuit Sensitivity Chart	10-10
10.7	In-flight Calibration Circuit	10-11
10.8	Typical Trace (In-flight Voltage Calibration)	10-12
10.9	Resistance Calibration Circuit	10-13
10.10	Typical Trace (Rough Air)	10-14
10.11	Typical Trace (Smooth Air)	10-15
11.1	History of Testing Time	11-13
11.2	Test Objectives	11-14
11.3	Typical In-Flight Wing Contour (33 MPH IAS)	11-15
11.4	Typical In-Flight Wing Contour (53 MPH IAS)	11-16
11.5	Longitudinal Trimmability (Unscaloped Wing)	11-17
11.6	Static Longitudinal Stability Trim Speed - 37 Knots IAS	11-18
11.7	Longitudinal Dynamic Stability (Stick Free) Pull Pulse	11-19
11.8	Longitudinal Dynamic Stability (Stick Free) Push Pulse	11-20
11.9	Effect of Rapid Power Reduction on Platform Attitude	11-21
11.10	Longitudinal Trimmability (Scalloped Wing)	11-22

**LIST OF ILLUSTRATIONS (Continued)**

11.11	Static Longitudinal Stability (Scalloped Wing) Trim Speed 28 Knots IAS	11-23
11.12	Longitudinal Trimmability (Scalloped Wing) with Simulated Irreversible Longitudinal Control System	11-24
11.13	Sideslip Characteristics	11-25
11.14	Dynamic Lateral/Directional Stability (Right Rudder Pulse)	11-26
11.15	Dynamic Lateral/Directional Stability (Left Rudder Pulse)	11-27
11.16	Spiral Stability - Right Bank	11-28
11.17	Spiral Stability - Left Bank	11-29
11.18	Time History of Coordinated Turn to Left	11-30
11.19	Time History of Right Turn Using Lateral Control Input Only	11-31
11.20	General Performance Information	11-32
11.21	Lift Variation with Angle of Attack	11-33
11.22	Results of Static Thrust Tests	11-34
13.1	Longitudinal Trim Indicator Calibration	13-4

#### 4.0 SUMMARY

This program was conducted to provide information on the aerodynamic characteristics, handling qualities, and stability and control in order to provide information on the flexible wing concept for possible future military applications.

Standard stability and control flight tests were conducted, where applicable, on a full sized manned Flexible Wing test vehicle incorporating the principle of center of gravity movement for longitudinal and lateral control.

Control forces and vehicle response to control input were investigated. As anticipated, high longitudinal and lateral control forces were encountered. Longitudinal control forces of approximately one hundred pounds were considered acceptable to the pilot. Lateral control forces of approximately seventy pounds were considered undesirable because they induced system stretch which reduced the total amount of available lateral control. Longitudinal response to control input was satisfactory and positive in sense, i. e. a forward shift in c. g. resulted in a nose down movement of the vehicle. Lateral response was masked by the high lateral forces, but was also positive in sense.

Earlier tests indicated the need for a rudder to facilitate cross-wind operations of a manned vehicle, and to augment the lateral control system for roll control.

Static longitudinal and lateral/directional stability tests were conducted throughout the greater portion of the speed range. A deterioration of longitudinal stability and a right wing down roll tendency at speeds above 40 knots were noted. Ground observer comments supported by in-flight photographs indicated a slight asymmetry of wing contour which tentatively has been determined as the cause of the roll-off tendency. The effect on longitudinal characteristics has not been evaluated, but is felt to be significant.

Additional testing was conducted with minor modifications to the wing configuration. As anticipated, a reduction in longitudinal control forces was accomplished by decreasing the basic wing stability margin. Additional tests showed that an irreversible powered control system could effectively increase static longitudinal stability and permit reduced control forces.

A cable installed in the wing trailing edge was found to be effective both longitudinally and laterally. Symmetrical variation of the cable length had a pronounced effect in inducing longitudinal pitching moments. Asymmetric variation of this cable tension appeared to be effective in inducing rolling moments. The use of this cable as a longitudinal and/or lateral trim or control device warrants further investigation.

Wing trailing edge flutter was effectively reduced by scalloping of the trailing edge. However, the installation of trailing edge battens completely eliminated such flutter.

In general, the concept of center of gravity movement for longitudinal and lateral control appears feasible. Optimization of the test vehicle's control system would be desirable for incorporation on a tactical vehicle. The incorporation of a rudder or other directional control device would be optional depending upon the proposed tactical use of the vehicle. Additional wind tunnel tests are deemed necessary to evaluate the effects of wing material and the fabrication thereof on wing contour characteristics.

## 5.0 CONCLUSIONS

1. The results of the flight test program indicate that tactical employment of the Flexible Wing with control provided through center of gravity movement is feasible for numerous applications including manned vehicles.
2. Control system used will be satisfactory for applications in which high control forces and low response rates are not critical.
3. For man-powered controls, additional research must be conducted to investigate other methods of control.
4. Further testing will be necessary with the test vehicle to isolate component drag so that performance data for future designs can be accurately applied.

## 6.0 RECOMMENDATIONS

The following recommendations, based on results of flight testing the manned Flexible Wing test bed, fall within two major categories - those related directly to the test bed, and those related to future development of an operational manned vehicle.

### Test Vehicle:

1. Conduct a full scale wind tunnel program to corroborate flight test data, and to obtain additional drag and thrust data. Specifically, drag of fuselage and truss should be obtained, and thrust for balanced forces at several dynamic pressures within the speed envelope of the vehicle.
2. Following a comprehensive tunnel program with the existing configuration of the vehicle, conduct a wind tunnel evaluation program of several modified lateral control systems.
3. Upon completion of the tunnel program, conduct a flight test program to acquaint government pilots with the flight characteristics and handling qualities of the test vehicle.

### Future Developments:

1. Conduct a complete detailed study and test program to obtain design data for an optimized wing configuration. Such a program should include the following considerations: fabric, direction of weave relative to wing shape; direction of seams relative to wing shape, leading and trailing edge shapes; camber built into wing in "flat" planform; location of maximum camber relative to wing shape. The last two variables can be compared to conventional wing camber and location of maximum camber.

2. Design, fabricate, and flight test an optimized manned vehicle incorporating the following considerations: a wing based on the results of the above program, a control system in which the aerodynamic or inertial feedback is optimized.

## 7.0 DESCRIPTION OF TEST BED

### 7.1 General Arrangement

Drawing AO4-1000 (Figure 7.1) shows the test bed as originally designed and fabricated. Figure 2.1 shows this configuration in flight. During the course of the tests, changes were made in the control system and a more powerful engine was installed. Drawing AO4-1000 ("A" change) Figure 7.2 shows the machine with these changes, and Figure 2.2 pictures the modified machine in the air.

### 7.2 Dimensions and Weights

Keel Length (and leading edge length)	. . . . .	28 ft.
Leading Edge Sweep Angle	. . . . .	50 degrees
Canopy Area (Flat Pattern with 45 degree sweep)	.	555 sq. ft.
Over all length	. . . . .	28 ft.
Over all height (wing horizontal)	. . . . .	12 ft. 2 in.
Engine (original)	. . Continental 0.200-A . .	100 H.P.
Engine (alternate)	. . Lycoming 0-360-A . .	180 H.P.
Propeller Dia. (Hartzell 2 bladed)	. . . . .	6 ft.
Design Gross Weight	. . . . .	2100 lbs.
Empty Wt. (Continental 0-200A Engine)	. . . . .	966 lbs.
Empty Wt. (Final Configuration)	. . . . .	1227 lbs.

### 7.3 Structural Details

#### 7.3.1 Platform

The wing, landing gear, power plant and pilot's cockpit are supported by a rectangular platform of conventional construction employing aluminum alloy skin, frames and stringers. The flat upper surface of the platform is equipped with standard cargo tie down rings arranged on 20 inch centers crosswise and fore-and-aft.

### 7.3.2 Wing Support Truss

Welded steel tubing is used for the wing support structure and engine mount. The upper part of this truss is in the form of a tripod with its apex at the wing pivot point.

### 7.3.3 Wing Keel

The keel is an aluminum alloy box beam of rectangular cross section. The width is constant along the length; the height is varied, and additional cap material is employed as necessary to produce an economical beam structure.

### 7.3.4 Leading Edge

The leading edges are hollow aluminum alloy spars, having a symmetrical streamlined cross section, and tapered toward both ends from a maximum section near the spreader bar attachment. The skins are formed from sheet aluminum alloy. An aluminum alloy channel at the maximum thickness station serves as a shear web. Wooden formers are bonded at intervals inside the leading edge. These serve to stabilize the skin and to locate the shear web properly during fabrication. The main attachment at the spreader bar is in the form of a hinge with the hinge line running axially and somewhat forward of the leading edge of the spar. The forward attachment is a spherical rod end. The wing membrane is attached along the trailing edge. Thus the membrane tension always acts in the plane of maximum stiffness of the spar, since the spar is free to align itself with the load.

### 7.3.5 Wing Spreader Bar

In order to hold the leading edges at the proper sweep angle, and to resist the inward and upward reactions due to membrane tension, a transverse steel tube truss is attached to the keel and leading edges. Each side truss is hinged to fold in the middle, thus permitting the leading edges to swing inboard to a position near the keel for stowage. This is a manual operation, involving removal of bolts and movement of the leading edges by hand.

### 7.3.6 Wing Membrane

The original wing membrane was fabricated from 1.85 ounce per square yard rip-stop Nylon, coated on both sides with 1/2 mil Mylar. The warp of the cloth was parallel to the trailing edge. This membrane was subsequently replaced by one of the same dimensions made of 7 ounce per square yard dacron impregnated with a pliable and impervious weather resistant compound. The trailing edge was straight and incorporated battens. After a series of tests with this configuration, the trailing edge was scalloped as shown in Figure 7.3, retaining the battens as pictured.

### 7.4 Power Plant

A Continental 0-200A four cylinder engine was installed initially, directly connected to a six foot diameter two-bladed Hartzell propeller. This engine developed 100 H. P. at 2700 R. P. M. It was enclosed in a tight fitting fiberglas cowl and equipped with a 15-inch diameter fan to facilitate cooling. The cooling system proved to be inadequate for continuous running at full power, so the cowling and fan were removed. This resulted in some improvement, but the cooling was still not entirely satisfactory.

The 100 H. P. engine was replaced by a Lycoming Model 0-300-A series engine which delivers 180 H. P. at 2700 R. P. M. The original propeller was installed, with increased pitch to absorb the additional power. It was recognized that the relationship of propeller diameter, R. P. M., and speed of flight were far from ideal, but optimization would have involved a geared engine and extensive hardware changes to accommodate a larger diameter propeller, all of which would have involved a great deal of calendar time and expense. The new engine was fitted with an exhaust aspirated cooling system which has proven to be adequate.

### 7.5 Landing Gear

A four wheel landing gear is employed. The wheels are supported by welded steel tube outriggers extending laterally from the four corners of the test bed platform. Wheel tread is 9 ft.; wheel base is 9 ft. 4 in. Cleveland Pneumatic Tool Co. No. 9126. Hydraulic shock absorbers originally designed for the front wheel suspension of another aircraft were adapted. These units as received incorporated 360-degree swiveling forks to take 10-inch smooth

contour wheels (Goodyear No. 9532039) and tires. At the front wheels the swivels are connected to the rudder pedals through a system of cables, bell-cranks and pulleys for steering. Detents are provided at the wheel swivels to disconnect them from the pedal system in case of over-load.

For installation at the rear wheels, the swiveling feature was locked and the wheel fork was replaced by a Ryan designed yoke to accommodate a Goodyear No. 9532101, 5.00 x 5 wheel and No. 9532302 disc type brake. The brakes are actuated by means of individual hydraulic cylinders on the rudder pedals, so that individual or dual operation is possible.

## 7.6 Control System

### 7.6.1 General

As originally designed and flown, the Flexible Wing test bed incorporated a "two control" system in which pitch and roll control were obtained by shifting the center of gravity of the test bed with respect to the wing. After completing a series of tests with the "two control" system, yaw control was incorporated, utilizing an aerodynamically balanced rudder operating in the propeller slipstream. The pilot's controls consist of the usual control column and wheel, and a set of rudder and brake pedals. A switch conveniently located on the control wheel controls an electric actuator to position the wing forward or aft with respect to the pivot point below the keel. This provides a means for trimming the machine longitudinally. The range of travel provided is 4.5 inches forward and 3.8 inches aft from the neutral point. No provision is made for lateral or directional trim.

### 7.6.2 Roll Control

Reference is made to the control system assembly in zone 3 of Drawing AO4-1000. As shown in this view, the wing keel is attached to AO4-1068 torque tube by means of two links AO4-1076. The torque tube is supported by bearings at each end, and carries a roll control arm AO4-1075 at the middle. Cables from the pilot's control wheel attach to the ends of the control arm. Another pair of cables attached at the ends of the control arm are anchored to the structure so as to limit the travel of the torque arm to plus or minus 9 degrees. This corresponds to a travel of plus or minus 135 degrees at the control wheel.

After initial tests the roll control was modified as shown on Drawing AO4-1000 ("A" change). The purpose of the modification was to reduce the amount of flexibility in the system. At the same time the travel of the control wheel was reduced from 135 degrees to 90 degrees, and provision was made to connect the rudder pedals into the roll system. The pulley on the side of the fuselage truss near the back of the pilot's seat was replaced by a bell-crank. Three holes were provided for attachment of the roll control cable, corresponding to 5, 7, or 9 degrees of roll.

#### 7.6.3 Yaw Control

As shown on Drawing AO4-1000 ("A" change), the final configuration of the test bed includes a 13.4 sq. foot rudder operating in the propeller slip stream. It has a symmetrical airfoil section (NACA 0006), a solid spruce leading edge, wooden ribs, and plywood skin. Its upper end is hinged to the aft portion of the wing keel. The lower end is supported by a steel tube vee brace, hinged on supports from the aft landing gear to permit the rudder to move up or down as necessary to follow changes in wing pitch. A cable control system connects to pedals in the pilot's cockpit.

#### 7.6.4 Pitch Control

The original arrangement of the pitch control linkage is best shown in the side view of Drawing AO4-1000. The wing support beam (AO4-1067) is pivoted at the apex of the wing support tripod and actuated by the system of links and bell-cranks as shown. Cables attached to the front and rear of the wing support beam are anchored to the supporting structure to serve as stops. These were set to permit the wing to move through the range from  $+3\frac{1}{2}$  degrees to  $+29\frac{1}{4}$  degrees, measured with respect to the test bed platform. This corresponds to a control column travel of  $34^\circ$ .

After initial test flights, the pitch control system was modified to improve its mechanical advantage and to reduce its flexibility. The revised system is shown on Drawing AO4-1000 ("A" change). With this arrangement, the wing incidence changes from  $21\frac{1}{2}$  degrees to 30 degrees while the control column travels a total of  $30^\circ$ .

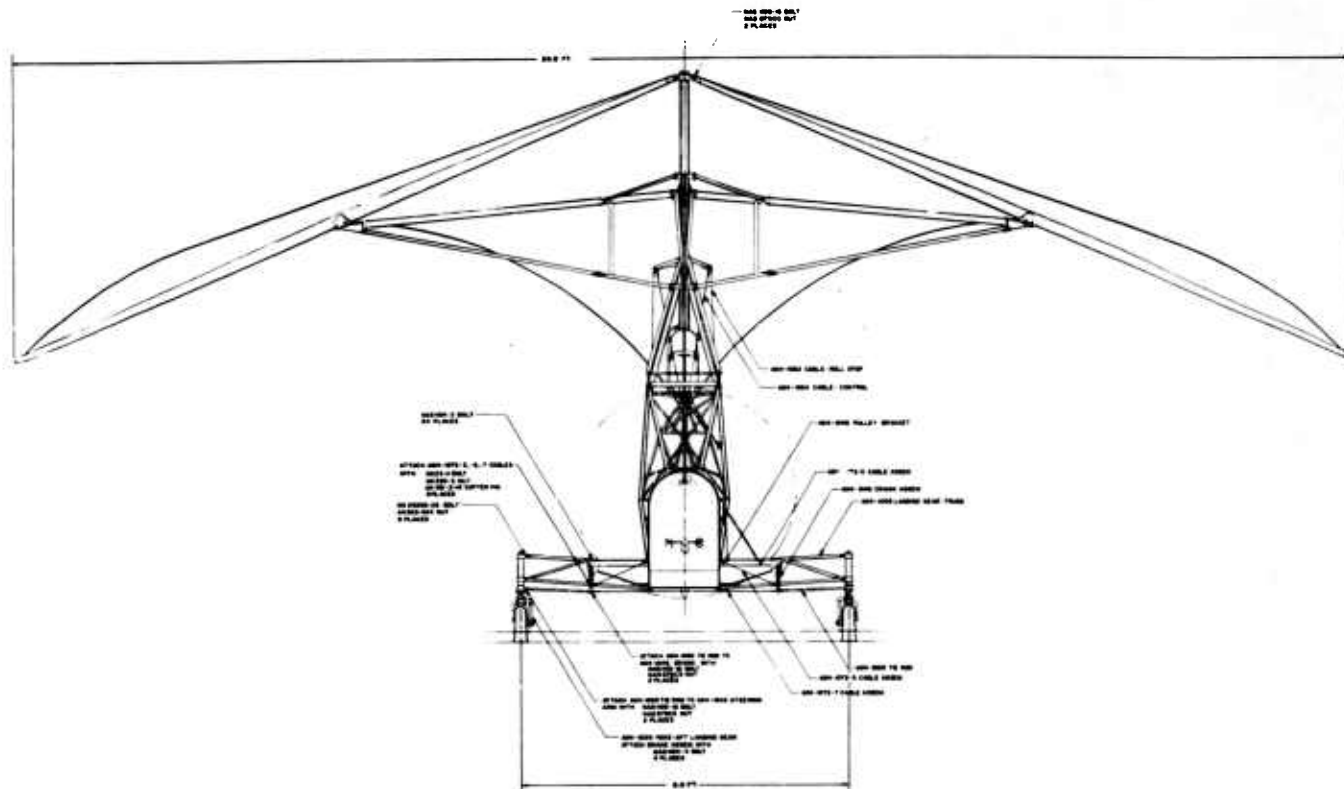

1

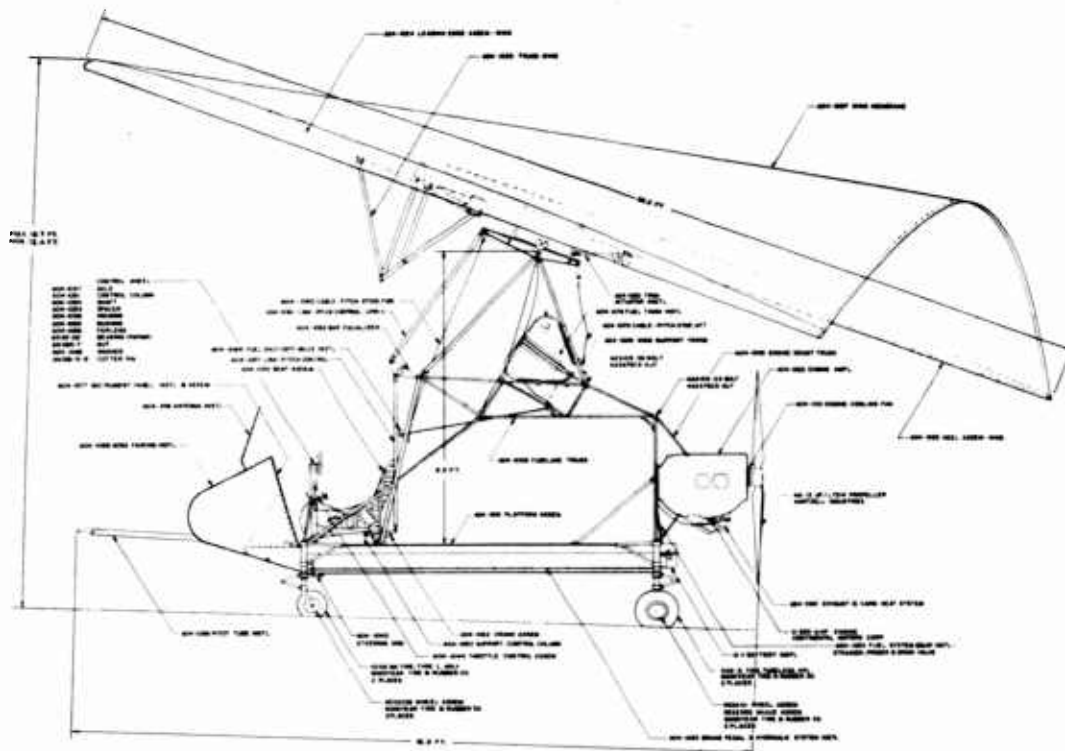

Figure 7.1

2









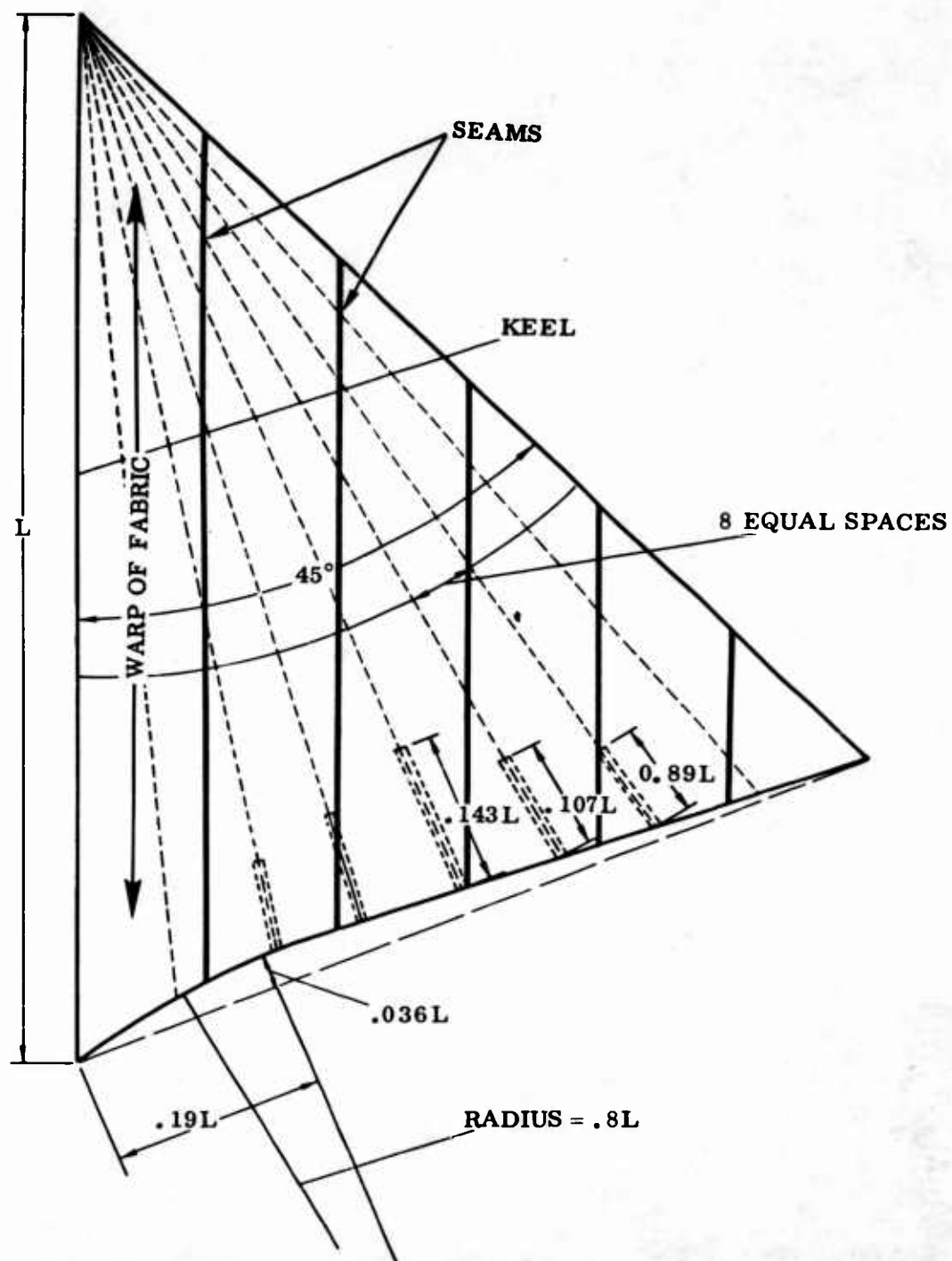

Figure 7.3 Flat Plan Geometry of Wing Scallop, Battens and Fabric Orientation

## 8.0 WEIGHT DATA

Figure 8.1 tabulates actual weights of the original components of the test bed as weighed before assembly. Their sum does not equal the empty weight given in Paragraph 7.2 for the reason that the table does not include instrumentation, miscellaneous bolts and other attaching parts, static balance weight on the wing keel, and other modifications to the aircraft during the course of the tests.

Actual gross weight and c. g. location for the various flights were determined by weighing the complete aircraft after major changes, and by computation after minor modifications. These data are tabulated in Figure 8.2. The vertical position of the c. g. was estimated.

ITEM	WEIGHT LB.	X ARM IN.	X MOM IN. - LB.	Z ARM IN.	Z MOM IN. - LB.
Radio Power Supply	7.00	50.0	350	55.5	399
Platform Assembly	98.28	125.3	12314	46.5	4570
Ldg. Gear Truss (Fwd)	13.18	71.8	946	46.4	612
Ldg. Gear Truss (Aft)	13.18	181.7	2395	46.4	612
Wheel Assy (Fwd)	34.80	69.0	2401	35.0	1218
Wheel Assy (Aft)	46.94	184.0	8637	35.0	1643
Nose Fairing	4.60	53.6	247	62.3	287
Instruments - Panel	15.12	60.4	913	71.6	1083
Brake Install.	8.00	124.0	992	48.0	384
Steering Linkage	6.66	70.1	467	38.8	258
Engine Mount	6.95	188.8	1312	69.3	482
Engine & Access.	223.05	200.4	44699	71.7	15993
Propeller	21.00	218.0	4578	73.0	1533
Exhaust + Air Heater	5.51	204.0	1124	63.0	347
Engine Cowl	10.15	200.3	2033	71.3	724
Fuselage Truss	24.91	115.1	2867	84.9	2115
Wing Truss	10.65	130.3	1388	128.1	1364
Fuel Tank Install.	5.45	148.2	808	114.5	624
Fuel Control	1.50	120.0	180	90.0	135
Seat Install.	8.24	92.0	758	60.0	494
Throttle Control	2.16	111.8	239	73.4	158
Battery	21.00	188.0	3948	54.0	1134
Pitot Head Install.	3.50	18.7	65	52.0	182
Equalizer Bar	4.44	121.3	538	109.5	486
Pitch Cont. Link, Upper	5.31	113.8	604	132.1	701
Pitch Cont. Link, Lower	1.50	100.2	150	80.7	121
Control Crank - Lower	.48	90.5	43	52.7	25
Link - Pitch Control	.42	81.8	34	52.6	22
Control Column	2.12	73.0	155	70.0	148

Figure 8.1 Table of Actual Weights  
(Continued Next Page)

Figure 8.1 Table of Actual Weights (Continued)

ITEM	WEIGHT LB.	X ARM IN.	X MOM IN. -LB.	Z ARM IN.	Z MOM IN. -LB
Support - Cont. Column	1.59	72.9	116	52.0	83
Control Wheel	2.75	74.8	206	78.0	214
Cable & Pulleys & Bkts.	7.56	110.0	832	98.0	741
Wing Trim Actuator	9.50	161.0	1530	141.0	1340
Beam - Wing Support	6.89	146.1	1007	150.0	1034
Torque Tube - Wing	3.81	148.0	564	152.0	579
Roll Control Arm	8.18	148.0	1211	153.0	1252
Wing Keel	35.34	146.5	5177	162.7	5750
Wing Leading Edges	76.84	111.5	8568	169.0	12986
Wing Fabric	14.62	180.6	2640	170.2	2488
Fabric Attach Strips	4.50	128.5	578	166.2	748
Spreader Truss	68.00	104.5	7106	155.2	10554

<b>FLIGHT NUMBERS</b>	<b>GROSS WT.</b>	<b>H. ARM *</b>	<b>V. ARM *</b>	<b>REMARKS</b>
1 through 4	1494	133.7	82.7	Continental Engine; No cowl; Rudder and support structure; 290 lbs. instrumentation.
5	1682	135.5	82.7	Lycoming Engine; Small battery; rudder and support struct. 209 lbs. instrumentation
6 through 10	1722	134.2	82.7	Same as above with 61 lb. battery instead of 21 lb. at station 77.5
11 through 17	1747	134.0	82.0	Same as above with 25 lb. NASA instrumentation added at Sta. 120
18 through 30	1847	134.8	80.5	Same as above with additional battery and case (100 lb) at Sta. 148.75

Figure 8.2 Table of Gross Weight and C.G. Locations

## 9.0 DESIGN CRITERIA & STRESS ANALYSIS

### 9.1 Design Conditions and Load Factors

DESIGN CONDITION	LOAD FACTORS	
	LIMIT	ULTIMATE
MANEUVER - HIGH ANGLE OF ATTACK $\alpha_w = 40^\circ$	2	3
MANEUVER - LOW ANGLE OF ATTACK $\alpha_w = 20^\circ$	2	3
GUST - VERTICAL DESIGN GUST VELOCITY 40 F. P. S.	2	3
GUST - HORIZONTAL ADOPTED	$\pm 5$	$\pm .75$
LANDING GEAR LOADS VERTICAL	2.34	3.5
LANDING GEAR LOADS SIDE - INWARD	.8*	.8*
LANDING GEAR LOADS SIDE - OUTWARD	.6*	.6*

\* FRACTION OF VERTICAL COMPONENTS

Figure 9.1 Design Conditions and Load Factors

## 9.2 Distribution of Loads to Wing Structure.

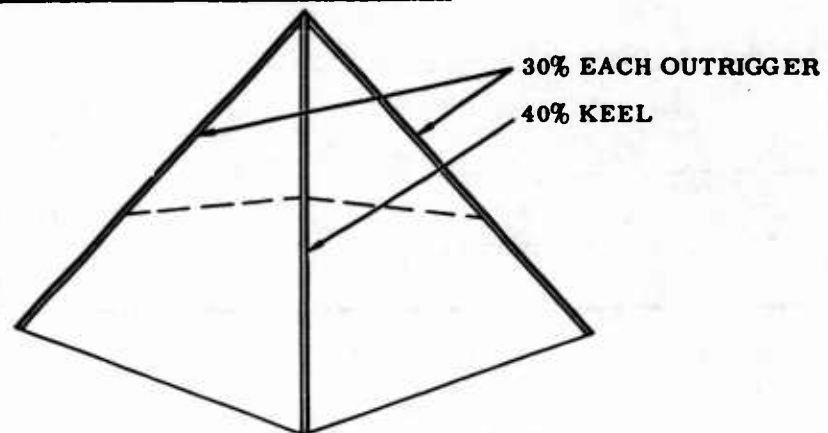

Figure 9.2

### Basic Dimensionless Airload Shear and Bending Moment Distributions

Shear  $S_{x/F}$  Dimensionless

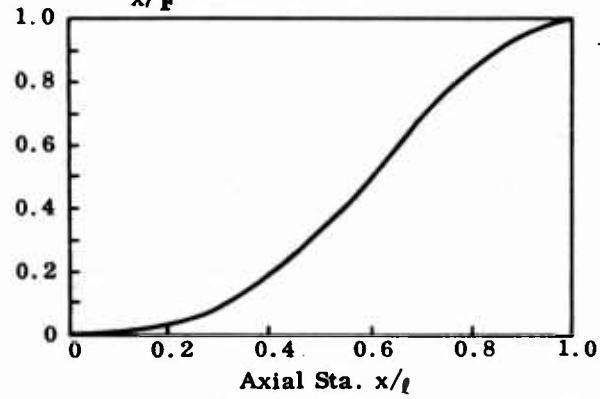

Figure 9.3

$M_{x/F l}$  Dimensionless

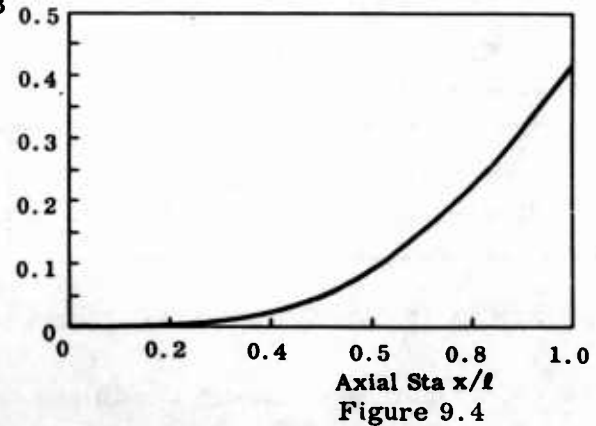

Figure 9.4

### 9.3 Load Factors

#### 9.3.1 Maneuver Envelope

With a wing area  $S = 555 \text{ Ft.}^2$  and a gross weight  $W = 2100 \text{ lb}$ , according with MIL-A-8861 (Ref. 2) the different speeds were computed:

$$V_H = 52.5 \text{ kts maximum level speed}$$

$$V_L = 1.40 V_H = 73.5 \text{ kts}$$

$$V_S = 29.9 \text{ kts For } W = 2100 \text{ lb}$$

$$k = 1.25 \text{ (} V_S \text{ factor) Ref. 2}$$

Limit Load Factor  $n_z = 2.0$  Ref. 2

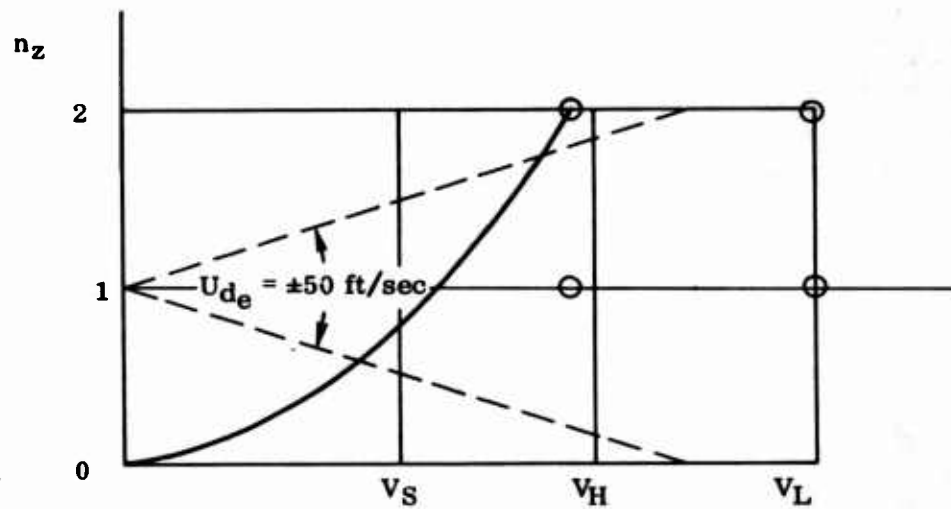

Figure 9.5  $V-n_z$  Diagram

### 9.3.2 Vertical Gust Envelope

Ref. 2

Design Gust Velocity: 40 FPS - EAS

Gust Equation:

$$n_z = 1 \pm K_{W_z} \frac{m \rho_o U_d V_e}{2 W/S}$$

$$m = C_{N_\alpha} = .042/\text{Deg.} = 2.41/\text{Rad} \quad (15^\circ < \alpha_W < 35^\circ)$$

$$K_{W_z} = \frac{.88 \mu}{5.3 + \mu} ; \mu = \frac{2W}{g c' m \rho_o 5}$$

For  $W = 2100$  lb.

$$\mu = \frac{2 \times 2100}{32.2 \times 14 \times 2.41 \times .002377 \times 555} = 2.93$$

Therefore  $K_{W_z} = .313$

The Gust load factor:

$$n_z = 1 \pm 1.009 \approx \begin{cases} 2.00 \\ \& \\ 0 \end{cases} \begin{array}{l} \text{Indicated in the} \\ \text{V-}n_z \text{ diagram.} \end{array}$$

### 9.3.3 Horizontal Gust Load Factor:

Ref. 2

$$n_y = \pm (\Delta n_z) K_{W_y} ; K_{W_y} = 1.0$$

$$= \pm 1.009 \left( \frac{1}{.313} \right)$$

$$= \pm 3.22 \text{ Too High, Not Applicable}$$

Adopted

$$n_y = \pm .500$$

#### 9.4 Summary, Stresses in Principal Wing Structural Members

The stresses shown in this section were taken from Ryan design notebooks entitled "Preliminary Structural Analysis, Model 140," Volumes I and II.

##### 9.4.1 Outrigger. Sta. 180 Critically Loaded Bending Stresses

###### About X-X axis

Critical condition (2) Low Angle of Attack  $\alpha_W = 20^\circ$

$$M_{x-x} = 25000 \text{ in lb} \quad (\text{Ult. Values})$$

$$P_c = 1810 \text{ lb}$$

Bending Stress

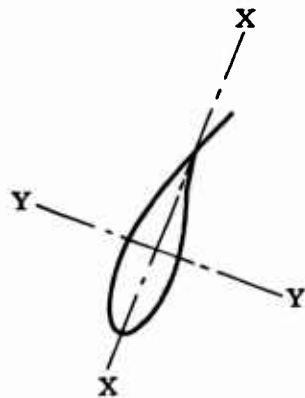

$$\text{Ultimate } f_u = \frac{Mc}{I} + \frac{P}{A} = -27890 \text{ PSI}$$

$$\text{Limit } (n_z = 2) f_{\text{LIMIT}} = -18600 \text{ PSI}$$

$$(n_z = 1) f = -9300 \text{ PSI}$$

$$f_{\text{cr}} = -28000 \text{ PSI (Ref. 3)}$$

$$\text{M.S.} = \frac{28000}{27890} - 1 \cong \underline{0}$$

###### About Y-Y Axis

Critical Condition (2) Low Angle of Attack  $\alpha_W = 20^\circ$

$$M_{y-y} = 73600 \text{ in lb} \quad (\text{Ult. Values})$$

$$P_c = -1810 \text{ lb}$$

### Bending Stress

$$f_u = \frac{Mc}{I} + \frac{P}{A} = -32850 \text{ PSI}$$

$$f_{\text{LIMIT}} = -21900 \text{ PSI}$$

$$(n_z = 1)f = -10950 \text{ PSI}$$

$$f_{\text{cr}} = 37350 \text{ PSI (Ref. 3)}$$

$$\text{M.S.} = \frac{-37350}{-32850} - 1 = +.14$$

### 9.4.2 Keel Span Sta. 96.94 - 115.0 Critical Shear Stresses

$$\text{Sta 96.94 S} = 4475 \text{ lb (Ult.)}$$

$$h = 7.2 \text{ in}$$

$$d = 8.0 \text{ in } d/h = 1.11 \quad K = 11.5 \text{ (Ref. 4)}$$

$$t = .050 \text{ in } \mu = .25 \quad E = 10^7 \text{ psi}$$

$$f_s = 1.33 \frac{4475}{2 \times .050 \times 7.2} = 8270 \text{ PSI (Ult)}$$

$$f_s = 5500 \text{ PSI (Limit)}$$

$$f_{s_{\text{cr}}} = 11.5 \times 10^7 \times \left(\frac{.050}{7.2}\right)^2 \times \frac{\pi^2}{12(1-\mu^2)} = 4870 \text{ PSI}$$

$$\frac{4870 \times (1.5)}{5500} = 130\% \text{ of limit stress acceptable.}$$

### Sta 157.75

$$S = 3611 \text{ lb (Ult)}$$

$$d = 6.96 \text{ in.}$$

$$h = 6.2 \text{ in. } d/h = 1.123 \quad K = 11.3 \text{ (Ref. 4)}$$

$$t = .051 \text{ in. } \mu = .25 \quad E = 10^7 \text{ psi}$$

$$f_s = 1.33 \times \frac{3611}{2 \times .051 \times 6.96} = 6760 \text{ PSI (Ult)}$$

$$f_{s_{cr}} = 11.3 \times 10^7 \times \left(\frac{.051}{6.96}\right)^2 \times \frac{\pi^2}{12(1-\mu^2)} = 6700 \text{ PSI}$$

$$f_{LIMIT} = 4500 \text{ PSI}$$

$$\frac{6700 \times 1.5}{4500} = 222\% \text{ of limit stress.}$$

#### 9.4.3 Keel - Sta 113.13 Critical Bending Stresses

Critical Condition (1) High Angle of Attack  $\alpha_W = 40^\circ$

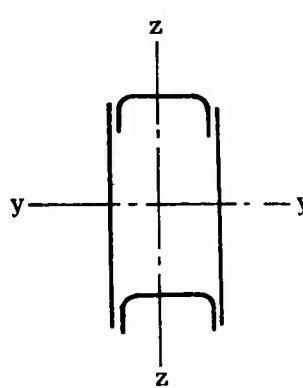
	<u>Angle</u>	$M_{y-y} = -85897 \text{ in lb}$	}	(Ult.)
		$P_c = -2397 \text{ lb.}$		
		$I = 12.247 \text{ in}^4$		$c = 4.01$
		$A = 1.479 \text{ in}^2$		
		$f_{ULT} = \frac{M.c}{I} + \frac{Pc}{A}$		

$$f_{ULT} = -29746 \text{ PSI}$$

$$f_{cr} = -28500 \text{ PSI (Ref. 3)}$$

$$M.S. = \frac{-28500}{-29746} - 1 = -.04$$

Lower Web:

$$c = 3.26$$

$$f_{ULT} = -24470$$

$$f_{cr} = -18250 \text{ PSI (Ref. 3)}$$

$$\underline{M.S.} = \frac{-18250}{-24470} - 1 = \underline{-.25}$$

Reduced Admissible Load Factor:

$$\underline{n_z} = \frac{-18250}{-24470} \times 2 = \underline{1.49}$$

9.4.9 Spreader Bar Loads and Stresses

Critical Flight Condition (2) Low Angle of Attack  $\alpha_W = 20^\circ$

$$\underline{\text{Upper Tube}} \quad 2 \frac{1}{4} \times .065 \quad A = .4462 \text{ in}^2$$

$$l = 85.3 \text{ in} \quad P_{cr} = -10500 \text{ lb (Ref. 3)}$$

$$\text{Ultimate Load } P_\mu = -9883 \text{ lb (Compression)}$$

Limit Load

$$(n_z = 2.0) P_\mu = -6590 \text{ lb (Compression)}$$

$$(n_z = 1.0) P_\mu = -3295 \text{ lb (Compression)}$$

$$\underline{M.S.} = \frac{-10500}{-9883} - 1 = \underline{+.06}$$

$$\underline{\text{Lower Tube}} \quad 1 \frac{3}{8} \times .049 \quad A = .2041 \text{ in}^2$$

$$f_{ALLOW} = 75000 \text{ PSI (Ref. 3)}$$

Ultimate Load  $P_l = 861$  lb (Tension)

Limit Load

$(n_z = 2.0) P_l = 5746$  lb (Tension)

$(n_z = 1.0) P_l = 2873$  lb (Tension)

Ultimate Stress  $f_t = \frac{8619}{.2041} = 42,250$  PSI

$M.S. = \frac{75000}{42250 (1.15)} - 1 = +.55$

9.5 Comparison of Calculated Axial and Shear Loads and Bending Moments With Strain Gage Test Results (PSI) ( $n_z = 1$ )

MEMBER AND CONDITION	AXIAL LOADS LB.		SHEAR LOADS LB.		BENDING MOMENTS IN. - LB.	
	Calculated	Strain Gage	Calculated	Strain Gage	Calculated	Strain Gage
Outrigger Sta. 94. $\alpha_w = 20^\circ M_x$			NOT CRITICAL			
Outrigger Sta. 94. $\alpha_w = 20^\circ M_y$			NOT CRITICAL			
Outrigger Sta 180 $\alpha_w = 20^\circ M_x$	-	-	-	-	8335	-
Outrigger Sta. 180 $\alpha_w = 20^\circ M_y$	-	-	-	-	24535	19970
Outrigger Sta. 94. $\alpha_w = 40^\circ P_c$ (compression)	-917	-	-	-	-	-
Keel Sta - 150 $\alpha_w = 40^\circ$ Shear	-	-	1204	1050	-	-
Keel Sta - 185 $\alpha_w = 40^\circ$ Shear	-	-	488	540	-	-
Keel Sta 113.13 $\alpha_w = 40^\circ M_y$	-	-	1492	-	28630	-
Truss Upper Tube $\alpha_w = 40^\circ P_c$ (compression)	-3295	2710	-	-	-	-
Truss Lower Tube $\alpha_w = 40^\circ P_t$ (tension)	2873	1880	-	-	-	-

Figure 9.6 Comparison of Calculated Axial and Shear Loads and Bending Moments

9.6 LIST OF SYMBOLS  
FOR  
DESIGN CRITERIA & STRESS ANALYSIS CALCULATIONS

A	Area of cross section
a	Subscript "allowable"
c	Distance from neutral axis to extreme fiber
c'	Average wing chord; (wing area ÷ span)
cr	Subscript "critical"
d	Width of web panel
E	Modulus of elasticity
EAS	Equivalent airspeed
F	Total airload acting on member
f	Stress
f <sub>limit</sub>	Limit stress, equal to 2/3 ultimate stress
FPS	Feet per second
g	Standard acceleration of gravity
h	Height of web panel
I	Area moment of inertia
K	Empirical constant
K <sub>w</sub>	Gust factor
l	Length of member; subscript "lower"
M	Applied moment or couple
m	Slope of curve C <sub>N</sub> vs α (normal force vs. angle of attack)
M.S.	Margin of Safety
M <sub>y</sub>	Horizontal load factor
M <sub>z</sub>	Vertical load factor
P <sub>c</sub>	Total applied column load
S	Wing area; Shear Force
s	Subscript "shear"
t	Thickness of web
u	Subscript "ultimate"
U <sub>d</sub> <sub>e</sub>	Gust velocity

$V_e$	Equivalent airspeed
$V_H$	Maximum level flight speed
$V_L$	Maximum dive speed
$V_S$	Stalling speed
$W$	Weight
$x$	Distance along longitudinal axis; subscript "X-Axis coordinate of point".
$x-x$	Longitudinal axis, as defined; subscript "about x-x axis"
$y-y$	Lateral axis, as defined; subscript "about y-y axis"
$\rho_o$	Mass density of air at sea level standard atmosphere.

## 10.0 INSTRUMENTATION

### 10.1 General

During the initial flights, oscillograph records were made primarily for the purpose of measuring stress levels in the principal structural members.

In the next phase, after a conference with the TRECOM instrumentation representative in July 1961, it was decided that instruments for recording transverse acceleration, vertical acceleration, pitch rate, roll rate, yaw rate, altitude, and airspeed would be tied into the existing Ryan readout system. Certain structural traces no longer important were removed from the oscillograph to make room for the needed aerodynamic information.

In September 1961, it became apparent that space reference traces of platform pitch and roll attitude would provide a basis for better flight data evaluation. A vertical free gyro was added to the test bed, and the pitch and roll functions were added to the oscillograph traces. Because of the longer flight times being accomplished and the large power drain of the new vertical gyro, a separate battery was installed to supply the gyro power. A potentiometer-type pressure transducer was added to the instrumentation to measure small changes in altitude so that rate of climb and descent performance data could be obtained with acceptable accuracy. This instrument gave greater track deflection on the records than that obtained from the NASA altitude transducer previously used.

A schedule which identifies the different oscillograph traces for each of the numbered test flight periods is presented in Figure 10.1.

### 10.2 Recording Oscillograph

A standard 26 channel Consolidated Engineering Corporation Oscillograph was used for recording the structural and flight data. The oscillograph was equipped with an extra thin photosensitive paper, which gave 45 minutes of actual recording time with a paper speed of 1 1/4 inches per second.

Figure 10.2 shows a layout of the arrangement of the oscillograph and the various other components of the instrumentation system on the test bed platform. Trim boxes A, B, C, and D shown in this layout, are used as storage and junction boxes for attenuator switches, channel balance potentiometers, resistance calibration circuits, etc.

The oscillograph was borrowed from Edwards Air Force Base, and it was necessary to remove it from the test bed before shipping the Ryan Flexible Wing to Langley Field, Virginia.

### 10.3 Measuring Instruments

The instrumentation system was composed of two different types of measuring instruments. Movements, positions and angles were measured with position-type potentiometers. Force and rate measurements were made with strain gage pickups.

Vertical acceleration was measured by means of a strain gage type accelerometer mounted on the wing keel, and oriented so that it would measure accelerations in a true vertical direction when the wing was flying at its normal 25 degree angle of attack. Transverse accelerations were measured by the same type of instrument which was rigidly attached to the support bracket for the roll gyro near the middle of the test bed platform.

It should be sufficient to look at a typical example of each of these instrument types to obtain an over-all picture of the Flexible Wing measuring system.

#### 10.3.1 Position Potentiometer Pickups

The space reference pitch and roll attitude and all of the position information were obtained from position potentiometer pickups. These pickups were of the simple slide wire potentiometer type with the wiper hooked by mechanical means to the unit whose position was being measured. A typical position potentiometer circuit is shown in Figure 10.3.

The Flexible Wing parameters that were measured by this method are tabulated in Figure 10.4.

#### 10.3.2 Strain Gage Pickups

The largest number of measurements on the Flexible Wing were made by instruments with strain gage pickups. A typical strain gage circuit shown in Figure 10.5, and the parameters that were measured by this type of pickup are tabulated in Figure 10.6.

### 10.3.3 Other Measurements

Only two parameters that were recorded were not measured by one of the types of instruments already mentioned. These are the Engine R. P. M. and the Delta Altitude measurements.

Engine R. P. M. was measured by taking a lead from the cockpit tachometer (electric type) and running it through a resistance network to the oscillograph.

For rate of climb and descent, a small potentiometer-type pressure transducer was used to measure small changes in altitude. The circuit for this transducer is identical with that of a typical position potentiometer.

### 10.4 System Accuracy

The main criterion used to determine the accuracy of the Flexible Wing instrumentation system was a record of the instrumentation voltage during recording. When the voltage is known for a particular record, it can be compared to the voltage during the calibration of the separate channels. If the instrumentation voltage is different on a particular record from what it was when calibrations were made, it is necessary to correct the recorded track deflection by the same percentage the instrumentation voltage has changed.

The method of determining the instrumentation voltage during flight and recording is by means of a pilot operated calibration switch. This switch places a portion of the instrumentation voltage across one of the oscillograph galvanometers, and thus gives a trace deflection. This deflection is proportional to the voltage and can be compared to the same signal trace during the calibration of the specific channels. The circuit of the in-flight calibration switch is shown in Figure 10.7. A typical flight record showing the in-flight 12 volt trace compared to the 12 V trace on the airspeed calibration is shown in Figure 10.8.

Other factors that determine over-all system accuracy are the reliability of calibration and the resolution of the traces on the records. All position and force parameters were physically calibrated every thirty days. The physical calibrations are considered to accurate to within  $\pm 2\%$ . Periodic functional checks were performed on all channels. These checks also served as a cursory re-check of the physical calibration

Strain gage circuits were checked by means of a resistance calibration ( $R_C$ ) circuit (Figure 10.9) incorporated in each trim box circuit. These  $R_C$  circuits placed a known resistance of 200K ohms across the strain gage bridge. The resulting deflection of the oscillograph record trace was then checked against the deflection of a comparable strain gage induced bridge unbalance.

Although these  $R_C$  circuits could also be introduced into the potentiometer circuits, the resulting oscillograph traces would be meaningless except under conditions of zero physical deflection of the measured parameter. Therefore, the potentiometer circuits were checked by physically moving the measured parameters to their limiting positions and noting the deflection on the oscillograph records.

The resolution of the traces on the records was adjustable by means of a toggle-type attenuation switch on each channel, which provided three different gain settings. The gain for each channel was determined by the resolution required for the most accurate reduction of data. The over-all accuracy of the instrumentation system, taking into account all sources of error was considered better than  $\pm 6\%$ , with the possible exception of altitude and airspeed. In these cases, the sensitivities of the available transducers were not properly matched with the range of altitudes and airspeeds being measured.

Flexible Wing flights should be conducted in very smooth air to obtain satisfactory quantitative data, because the records become quite complex when recorded in rough air and are very hard to read accurately. Examples of flight records taken in rough and smooth air are shown in Figure 10.10 and 10.11 respectively.

In summary, the instrumentation system provided satisfactory data with the exception of that pertaining to altitude and airspeed. In future tests the altitude and airspeed transducers should be replaced with units having greater sensitivity in order to obtain more accurate indications of small changes in air density and velocity.

CHANNEL NUMBER	JUNE							AUGUST							SEPTEMBER							OCTOBER							NOVEMBER							DATE																										
	22	23	28	29	1	2	3	21	22	24	24	24	29	20	25	28	29	6	10	17	18	19	20	24	25	30	2	3	8	9	10	14	15	1	2		3	4	5	6	7	8	9	10	11	12	13	14	15	16	17	18	19	20	21	22	23	24	25	26	27	28
0	LOWER REFERENCE TRACE																																																													
1	BENDING-LEADING EDGE (CHORDWISE)																																																													
2	BENDING-LEADING EDGE (BEAMWISE)																																																													
3	CONTROL WHEEL ROLL FORCE																																																													
4	LEADING EDGE AFT-BEAMWISE BENDING																																																													
5	LEADING EDGE AFT-CHORDWISE BENDING																																																													
6	ROLL-WING VS PLATFORM POSITION																																																													
7	PLATFORM VS RELATIVE AIR (PITCH ANGLE)																																																													
8	PLATFORM VS RELATIVE AIR (YAW ANGLE)																																																													
9	TENSION -WING TRUSS LOWER TUBE																																																													
10	WING FORE AND AFT POSITION VS PIVOT POINT (LONGITUDINAL TRIM)																																																													
11	CONTROL COLUMN PITCH FORCE																																																													
12	VERTICAL SHEAR-KEEL, FORWARD																																																													
13	VERTICAL SHEAR-KEEL, AFT																																																													
14	PITCH ANGLE; WING KEEL VS PLATFORM; ALSO CONTROL COLUMN POSITION VS PLATFORM																																																													
15	LEADING EDGE AXIAL COMPRESSION																																																													
16	WING TRUSS UPPER TUBE AXIAL COMPRESSION																																																													
17	PITCH ANGLE-WING KEEL VS RELATIVE AIR																																																													
18	KEEL/L. E. APEX VERTICAL REACT.																																																													
19	KEEL/L. E. APEX LATERAL REACT.																																																													
20	ENGINE R. P. M.																																																													
21	ANGULAR POSITION-RUDDER																																																													
22	REF. TRACE-60% OF TAPE WIDTH FROM TAPE UPPER EDGE																																																													
23	ALTIITUDE (NASA)																																																													
24	RESISTANCE CALIBRATION-12 VOLT BRIDGES																																																													
25	AIRSPEED (NASA)																																																													
26	AIRSPEED-RYAN BENDING BEAM																																																													
27	UPPER REFERENCE TRACE																																																													

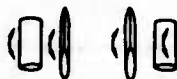

Figure 10.1 History of Oscillograph Instrumentation

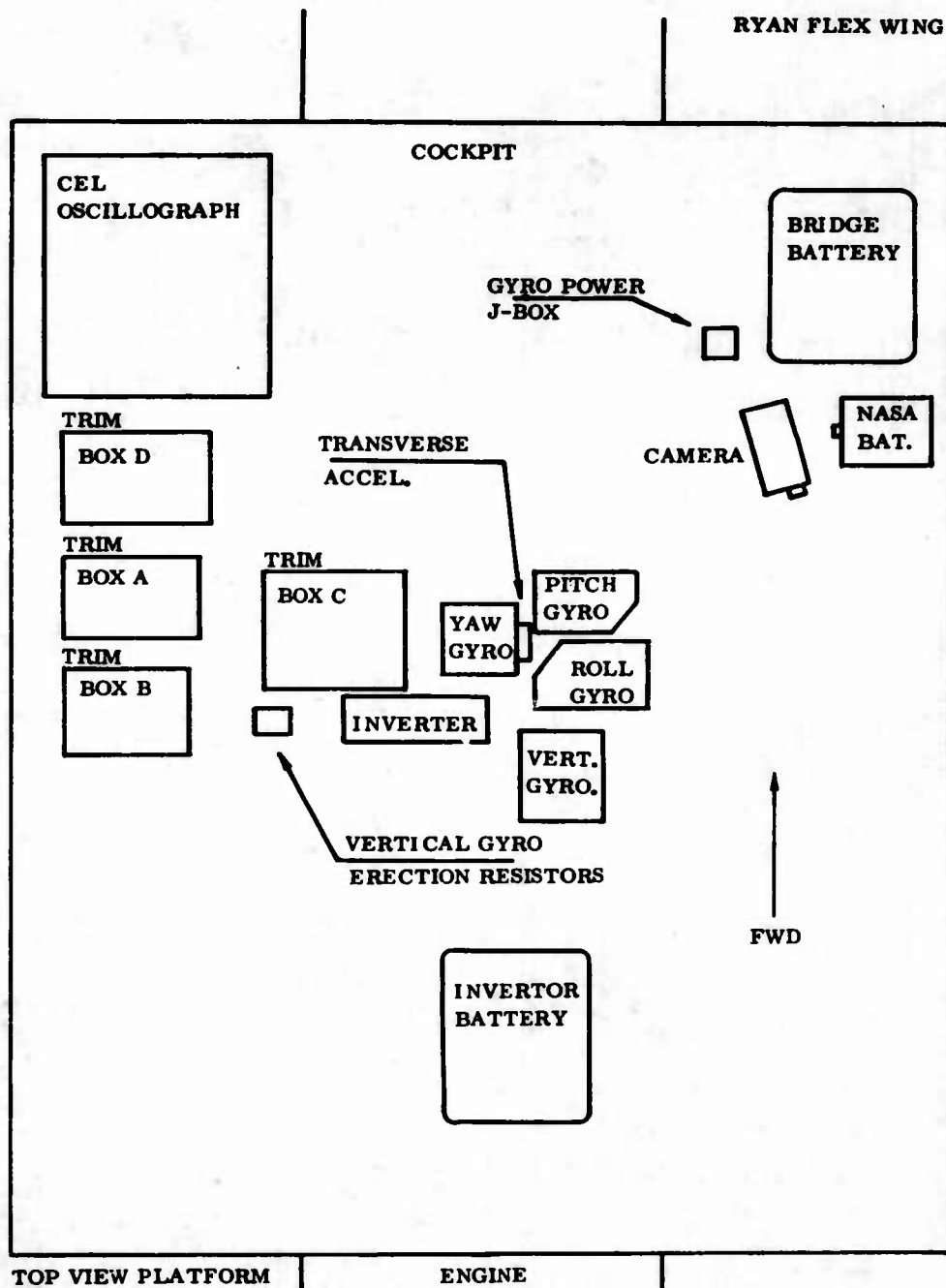

Figure 10.2 Instrumentation Layout

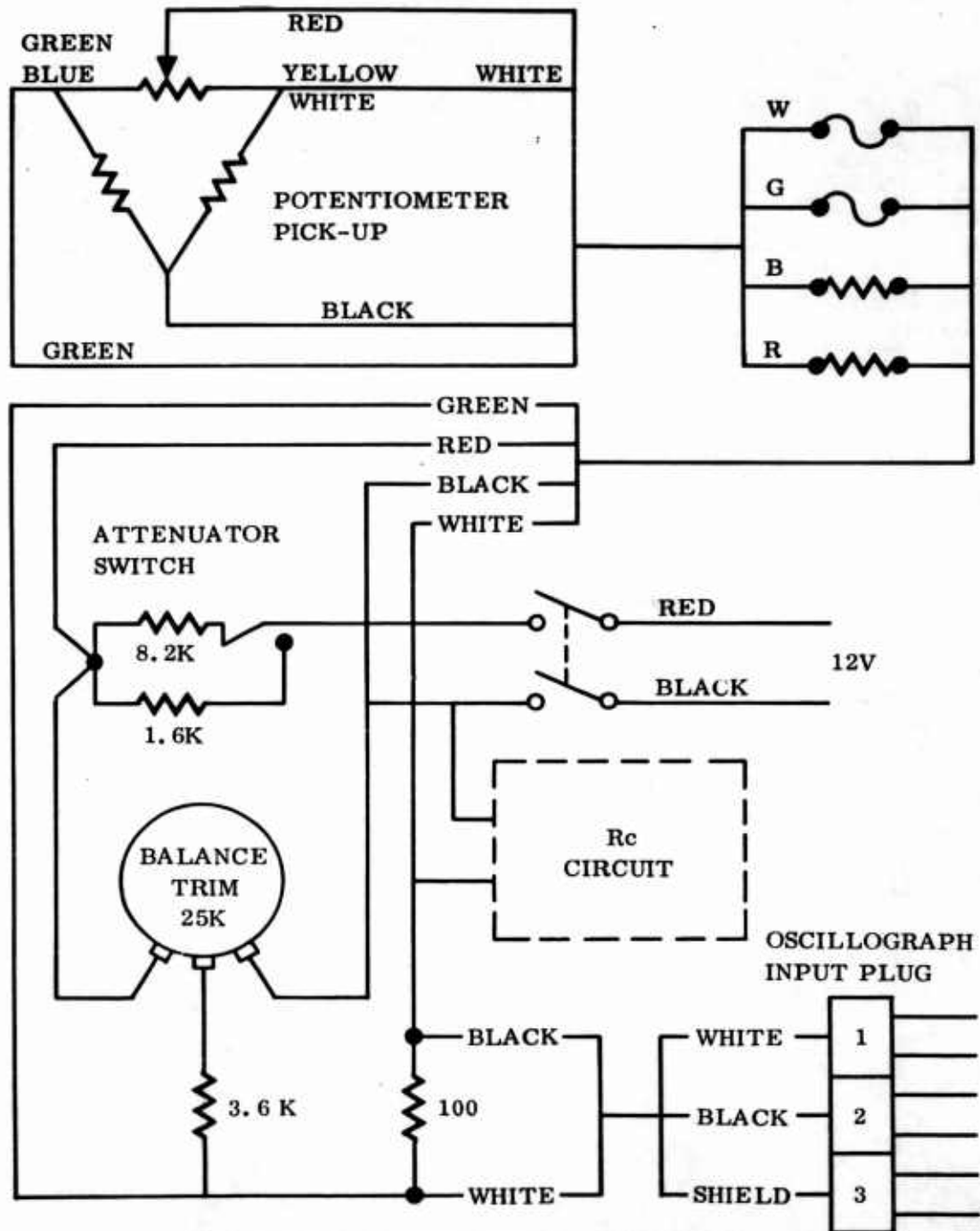

Figure 10.3 Typical Potentiometer Circuit

<u>Oscillograph Channel No.</u>	<u>Function Measured</u>	<u>Galvanometer Type</u>	<u>Sensitivity Per Inch Trace Deflection</u>
6	Roll Position, Surface/ Platform	7-318	14°
7	Relative Air Platform Pitch	7-339	22°
8	Relative Air Platform Yaw	7-318	18°
10	Surface Trim Position	7-315	6 inches
13	Roll Attitude	7-315	13°
14 a)	Pitch, Surface vs. Platform Position	7-318	6°
b)	Stick Position, Control Column		21°
16	Pitch Attitude, Space Ref.	7-315	9°
17	Relative Air Surface Pitch	7-318	20°
21	Rudder Angle Position	7-338	20°

Figure 10.4 Potentiometer Circuit Sensitivity Chart

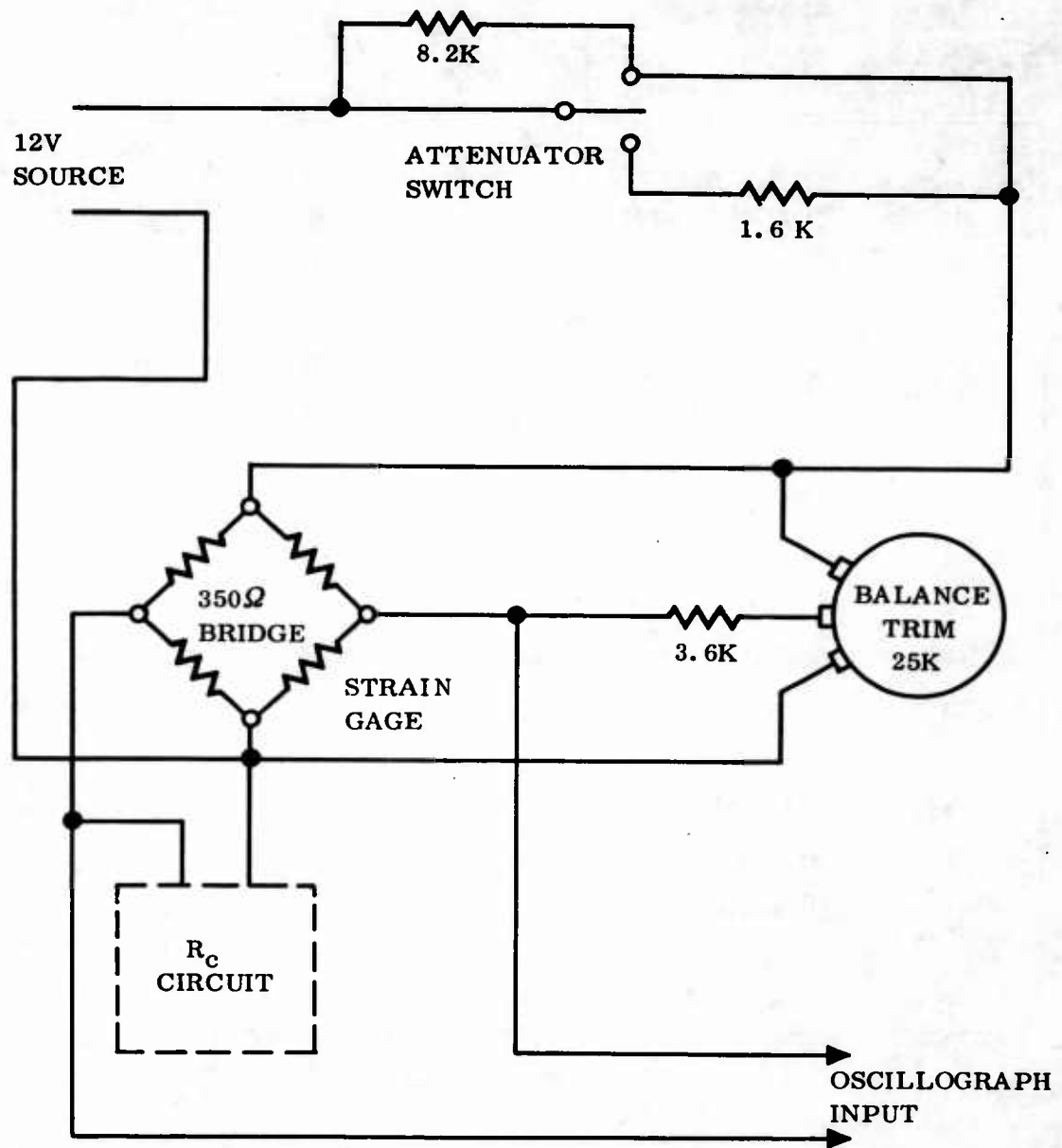

Figure 10.5 Typical Strain Gage Circuit

<u>Oscillograph Channel No.</u>	<u>Function Measured</u>	<u>Galvanometer Type</u>	<u>Sensitivity Per Inch Trace Deflection</u>
1	Transverse Acceleration	7-315	2.2 gs
2	Vertical Acceleration	7-339	.83 gs
3	Roll Force, Control Wheel	7-315	230 lbs.
4	L. E. Aft Bend Normal to Surface	7-318	27,000 in. lbs.
5	L. E. Aft Bend in Surface Plane	7-339	39,000 in. lbs.
9	Cross Truss Tube Tension	7-339	4100 lbs.
11	Pitch Force, Control Column	7-315	110 lbs.
12	Keel Vertical Shear Fwd.	7-315	1090 lbs.
15	Pitch Rate	7-315	.469 rad/sec
18	Yaw Rate	7-315	.450 rad/sec
19	Roll Rate	7-315	.422 rad/sec
23 a)	Altitude (NASA)	7-339	3450 ft.
25	Airspeed (NASA)	7-315	50 mph - 1 in. def.
26	Airspeed, Bending Beam (Ryan)	7-339	No. Calib.

Figure 10.6 Strain Gage Circuit Sensitivity Chart

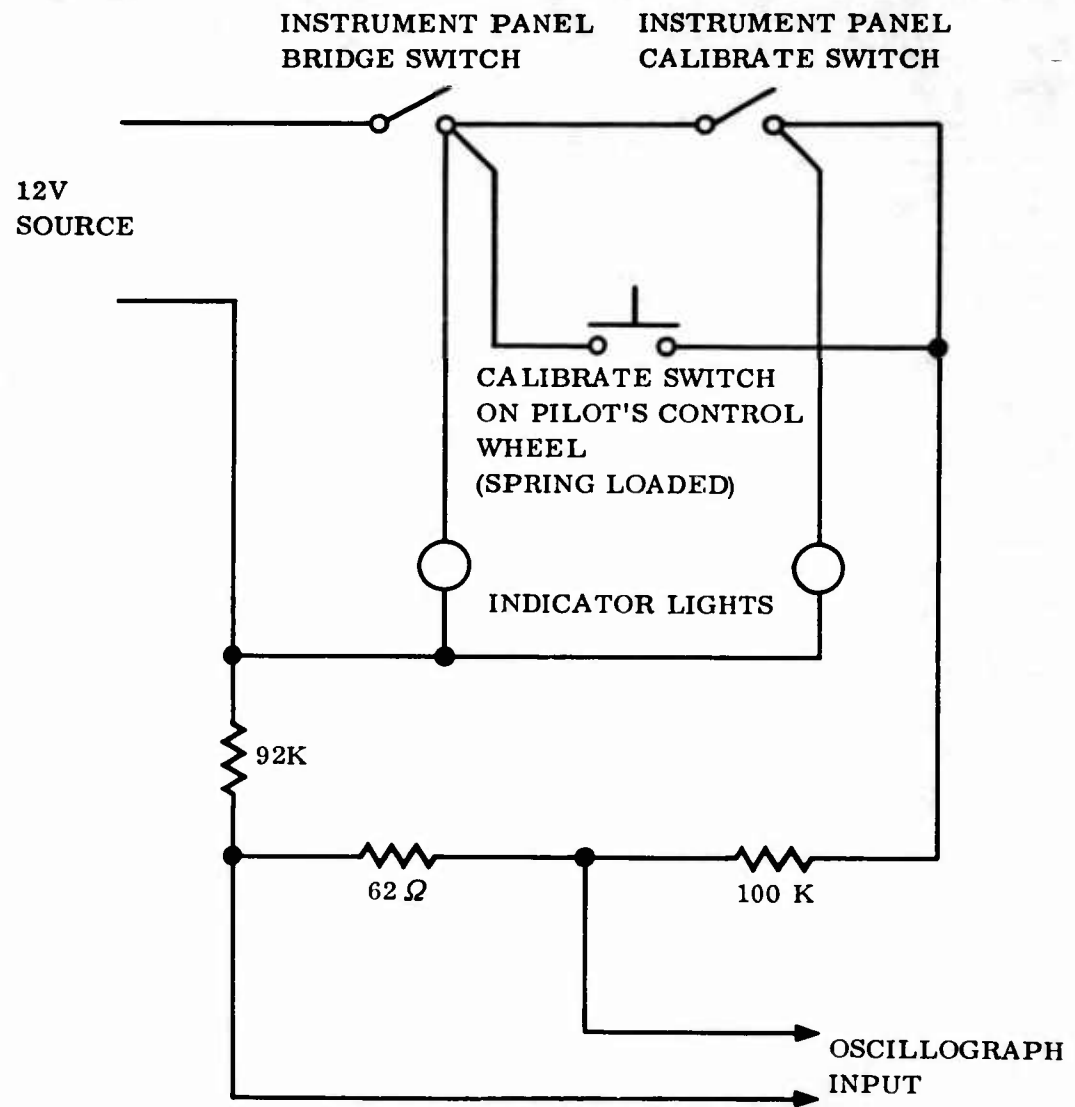

Figure 10.7 In-Flight Calibration Circuit

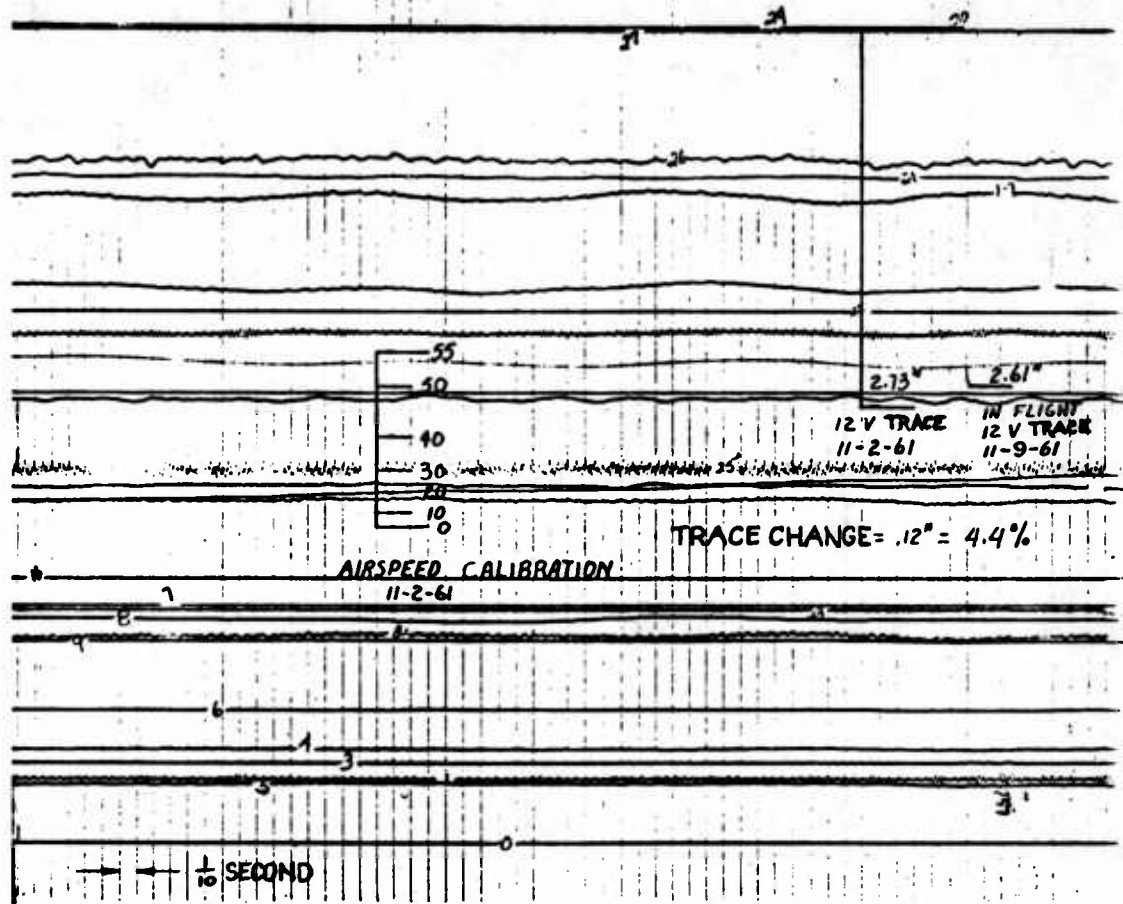

Figure 10.8 Typical Trace (In-Flight Voltage Calibration)

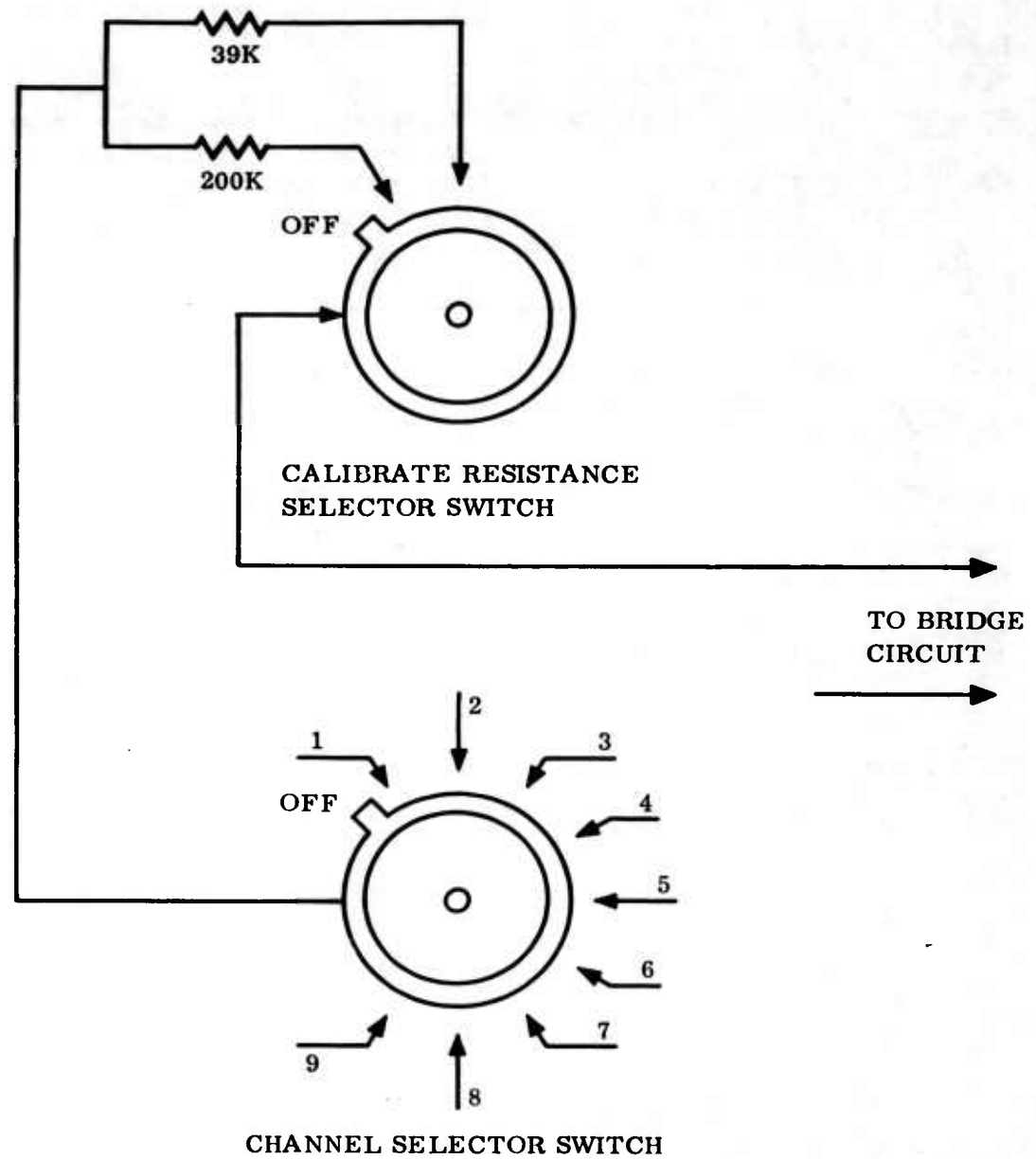

Figure 10.9 Resistance Calibration Circuit

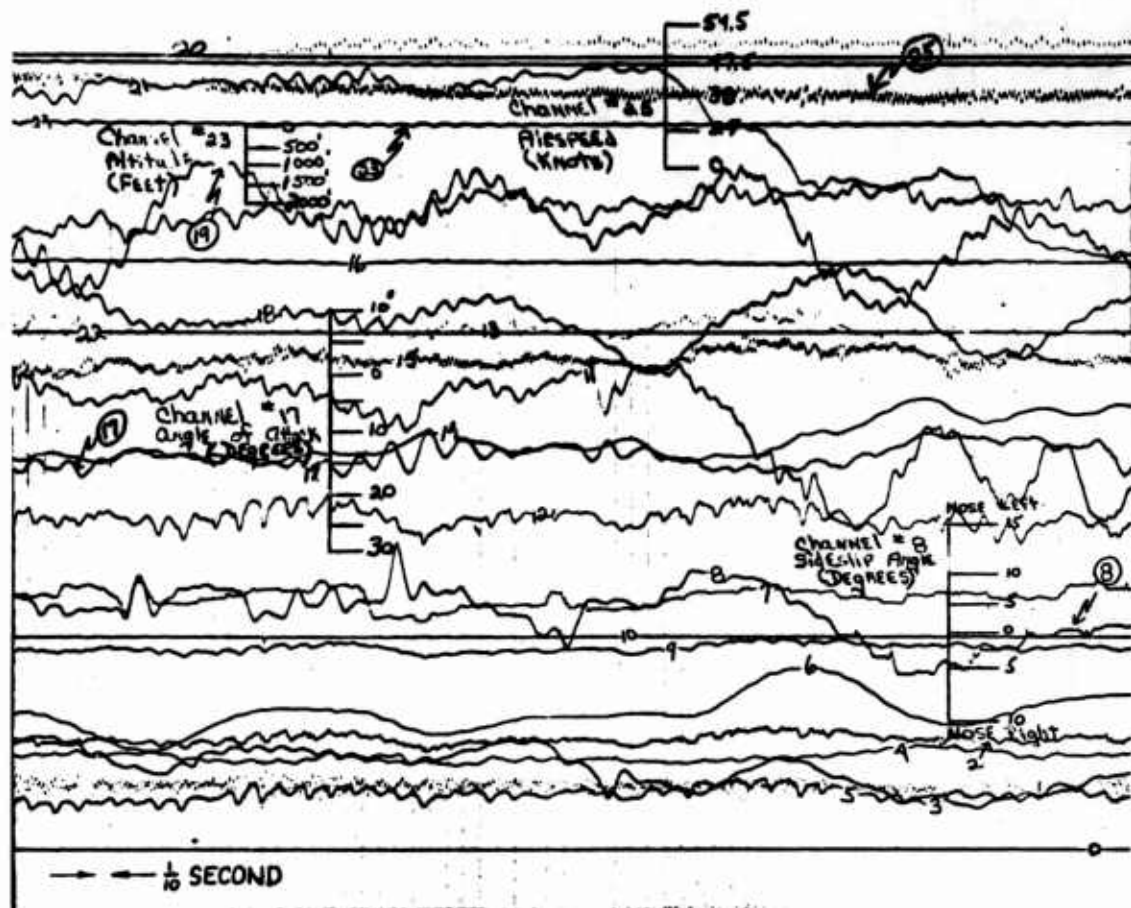

Figure 10.10 Typical Trace (Rough Air)

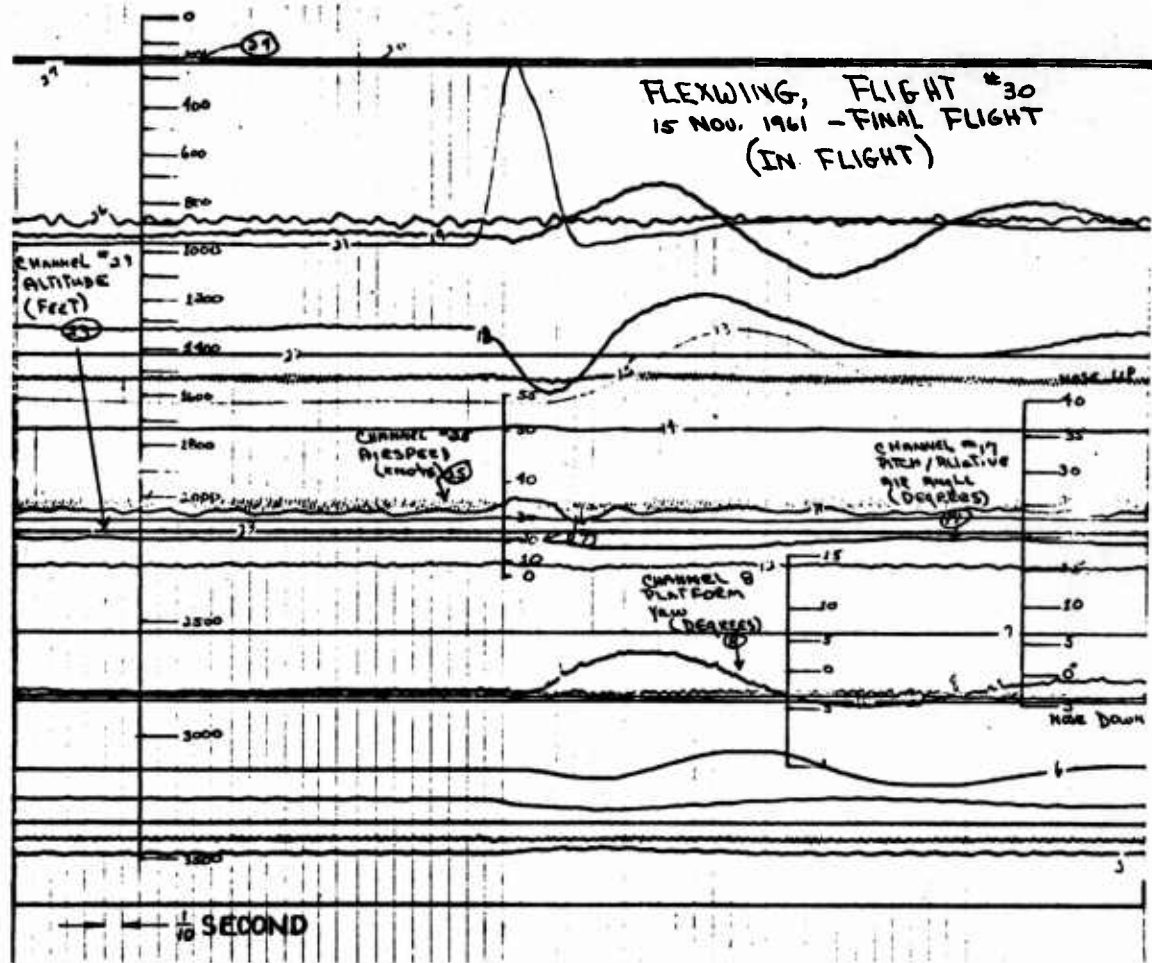

Figure 10.11 Typical Trace (Smooth Air)

## 11.0 FLIGHT TESTS

### 11.1 Introduction

The primary purpose of the flight test program covered by this report was to evaluate the stability and control characteristics of a Flexible Wing vehicle utilizing the principle of center of gravity movement for longitudinal and lateral control. The test vehicle had manually operated lateral and longitudinal control systems. An electrically operated longitudinal trim device was also incorporated in the design.

Prior safety, flight, and functional tests indicated the desirability of a directional control device to facilitate cross-wind operations and to augment lateral control. The vehicle used in the presented test program had a manually operated rudder installed for such purpose. Quantitative as well as qualitative data were obtained, and are presented.

A history of time spent in testing and total airborne and engine time are presented in Figure 11.1. Individual flight reports are included in Appendix 13.1.

### 11.2 Procedures

Standard test procedures as outlined in Reference I were followed wherever applicable. Deviations from or the exclusion of certain standard tests were dictated either by the characteristics of the vehicle or in the interest of safety. Wind tunnel data received subsequent to the design and construction of the test vehicle were not in agreement with wind tunnel data used as design criteria and showed substantial reduction in the structural safety factor. The behavior of the wing during stall operations was also ~~questionable~~. Therefore, it was considered advisable to eliminate those tests which might result in structural failure or uncontrollable flight, rather than delay the test program by major design modifications. The effect of this decision on the accomplishment of the test objectives is shown in Figure 11.2.

### 11. 2. 1 Longitudinal Characteristics

Standard procedures were followed to determine longitudinal trimmability and static and dynamic longitudinal stability. Longitudinal maneuvering force gradients were not evaluated due to structural considerations. Non-standard test techniques were used in evaluating stability characteristics with an irreversible control system. An irreversible system was simulated by mechanically locking the control column in the neutral position. The trimmability of this configuration was investigated by changing the trim setting and noting the ability of the vehicle to stabilize on the new trim airspeed. The greater portion of the trim range was investigated.

The effect of a rapid power reduction on the longitudinal dynamic characteristics was also investigated. With no pilot control input (hands off), power was rapidly reduced from the cruise setting to idle, and the resulting changes in platform attitude noted.

### 11. 2. 2 Lateral/Directional Characteristics

Standard procedures were used in evaluating static and dynamic lateral/directional stability characteristics. Spiral stability and rudder effectiveness were also evaluated by standard methods. Rudder hinge moment and pedal force characteristics were considered of secondary interest and no attempt at a quantitative evaluation was made.

Vehicle response to lateral control input was evaluated qualitatively by the pilot.

### 11. 2. 3 Performance

Instrumentation configuration and accuracy precluded conducting an extensive performance test program. Rate of climb and rate of descent data were obtained as by-products of the stability and control tests. Take-off distances were calculated from time histories of take-off runs.

Reduction of the flight test data to basic coefficient form was limited to a cursory check of the variation of lift with angle of attack because of the following undetermined influencing factors:

1. Airspeed position error calibration was not available.
2. In-flight thrust values were not obtained.
3. The drag and lift of the test vehicle, less wing, were not available.

Although estimates could have been obtained for these values which would have been accurate enough at higher flight speeds, such accuracy would not have been satisfactory for the speed range of the test vehicle.

#### 11.2.4 Other Areas of Investigation

Wing contour characteristics were investigated with the aid of an airborne motion picture record of the wing trailing edge and groundborne motion pictures of the entire wing during the low-level fly-bys. Additional in-flight photographic data were obtained from an aircraft flying in close proximity to the test vehicle.

Qualitative observations and photographic data were obtained for the evaluation of the effect of varying the tension in the wing trailing edge cable. The cable tension was increased incrementally, and low-level fly-bys performed at each setting. Qualitative pilot comments concerning control forces encountered were also obtained.

Figure 11.3 and 11.4 show typical contour irregularities which were investigated.

#### 11.3 Test Results

Qualitative test results were primarily based on pilot comments, although observer comments and analysis of photographic data were also utilized.

Quantative test results were obtained from reduced oscillograph data and pilot instrument panel readings. A detailed description of the oscillograph instrumentation is presented elsewhere in this report.

Correlation between the pilot's airspeed indicator readings and the recorded airspeeds was inconsistent, although groundborne calibrations showed no appreciable error in either system. It was assumed that undetermined in-flight effects were introducing errors in either or both systems.

In the following presentation of results, the two sources of airspeed data are identified by the units of velocity used, i. e., miles per hour or knots. Data presented in miles per hour were obtained from the pilot's instrument panel while data presented in knots were recorded oscillograph data. It is felt that this inconsistency in presentation is necessary to prevent contradictory interpretations of the results.

#### 11.3.1 Longitudinal Characteristics

Qualitative pilot comments concerning longitudinal trimmability indicate favorable characteristics at speeds below 40 knots. Above 40 knots, the pilot reported difficulty in obtaining the proper trim setting for a given trim speed. A change in procedure, in which the pilot established a given trim setting and then attempted to settle on a trim speed, produced similar difficulties. Oscillograph data presented in Figure 11.5 graphically shows this characteristic.

The long period dynamic stability characteristics as reported by the pilot, are also affected by the trim speed. Below 40 knots, the vehicle exhibited excellent damping, returning to trim speed within one to two cycles. Above 40 knots, divergence was apparent. The true character of the oscillation could not be evaluated because of the movement of the control column with speed changes. As the control column reaches its travel limit, additional damping is introduced by platform induced moments.

In evaluating static longitudinal stick-free stability, the pilot noted acceptable but high control forces. Positive stability was present throughout with no indication of force reversal. Figure 11.6 presents stick force versus airspeed for a trim speed of 37 knots. The slope of the curve appeared unaffected by trim speed or power setting. The average slope is about twenty-two pounds per knot (22 lb/kt.). The control system friction was low compared to the stick forces involved, resulting in a negligible trim speedband.

Short period dynamic longitudinal stability was reported by the pilot as possessing good damping qualities. Figures 11.7 and 11.8 present time histories of the short period oscillation. The period of the oscillations is approximately 2.4 seconds with a time to one-half amplitude of about 1.4 seconds.

The effect of power reduction on longitudinal equilibrium was reported by the pilot as being very significant. As is shown in Figure 11.9, a rapid power reduction results in an abrupt change in platform attitude. In the interest of safety, the pilot restricted the amplitude of the oscillation with a nose down control force. A similar test was performed with the control column locked in the neutral position. The pilot reported a very low amplitude pitch disturbance resulting from the power reduction. No oscillograph data is available for this test. The trim change required to maintain static equilibrium was reported as negligible by the pilot.

A reduction in stick force requirements was accomplished by reducing the stability margin of the wing. Scalloping of the wing trailing edge for contour purposes resulted in a decrease in longitudinal trimmability and static longitudinal stability as shown in Figures 11.10 and 11.11 respectively.

Figure 11.12 shows the results of a simulated irreversible control system on longitudinal trimmability. The simulation was accomplished on the scalloped wing and indicates an improvement of about three hundred and fifty percent (350%) in the stability margin, as determined from the slope of trim setting versus indicated airspeed.

### 11.3.2 Lateral/Directional Characteristics

During straight and level unaccelerated flight, the pilot reported a control wheel deflection to the left of approximately thirty (30) degrees. Left rudder was also required to prevent right wing roll. Engine torque effect on fuselage attitude has been determined to be the cause of the control wheel deflection. The right wing down roll tendency has tentatively been attributed to wing contour asymmetries. Since no lateral or directional trim device was available on the vehicle, all oscillograph data reflects the control requirements for trimmed flight.

The sideslip capability of the test vehicle (Figure 11.13) was dictated by the lateral control available. Approximately five degrees of sideslip was

sufficient to require full lateral control for static equilibrium. Rudder deflection of twelve degrees was required to produce five degrees of sideslip. Due to the location of the rudder, its effectiveness was influenced by power setting. The rudder, operating in the propeller slipstream showed increased effectiveness with increased power.

Rudder and lateral control pulses produced lateral/directional oscillations which exhibited positive damping characteristics. Figures 11.14 and 11.15 are time history records of the dynamics of lateral/directional oscillations. The period of the oscillations is approximately two and one-half (2.5) seconds and the time to half amplitude approximately one and one-half (1-1/2) seconds. Spiral stability characteristics are also apparent from these tests.

The results of tests performed to evaluate spiral stability are shown in Figures 11.16 and 11.17. In banks to the right, the vehicle exhibited neutral stability. To the left, spiral divergence was apparent.

An example of the control deflections and forces required in turns accomplished with coordinated lateral and directional control inputs are shown in Figure 11.18. Turns with lateral control alone required undesirably high control forces, as shown in Figure 11.19. The sensing of the response was positive in either case. The pilot preferred to execute all turns with coordinated control inputs because of the reduced forces required, and the increased rate of response.

Throughout the testing period, the pilot had commented on the right wing roll-off tendencies at high speeds. At an indicated airspeed of approximately fifty-three (53) miles per hour, full left rudder was required to maintain straight and level flight. A qualitative investigation of a possible lateral trim device was made during the latter part of the test program.

The wing trailing edge cable was ground adjusted to provide an asymmetry of one inch between left and right wings, the right wing having the higher tension. Subsequent flights revealed a negligible amount of left rudder required in the high speed regime.

### 11.3.3 Performance

Figure 11.20 presents, in tabulated form, that performance data which was readily obtainable from oscillograph and pilot instrumentation data. This

data is being presented primarily to give the reader a general feel for the vehicle's flight regime and performance range.

Good correlation between wind tunnel and flight test values of lift variation with angle of attack was obtained and is presented in Figure 11.21. Flight test values have been calculated assuming no airspeed indicator position error and approximating instantaneous gross weight. The wing angles of attack were obtained as the sum of measured platform angle of attack and measured wing pitch position relative to the platform. Therefore, a comparison of the slopes of the curves has more significance than a comparison of the absolute values of lift coefficient.

Flare capabilities were investigated by the pilot at various approach speeds. The deceleration characteristics of the vehicle were reported to be such as to result in near stall speeds at the bottom of the flare. The pilot found it advisable to add some power in all landing flares.

A comparison of the results of static thrust tests for the Continental and Lycoming engines is presented in Figure 11.22.

#### 11.3.4 Wing Contour

The results of tests for the correction of undesirable wing contour characteristics were qualitative in nature.

Initial scalloping of the wing trailing edge substantially reduced trailing edge flutter. The subsequent installation of apex-oriented battens completely eliminated trailing edge flutter on both the scalloped and unscalloped wing.

Scalloping initially appeared to correct wing contour irregularities. However, on each flight subsequent to the installation of the scalloped wing, the irregularity became more pronounced than on the preceding flight. Final irregularity showed no improvement over initial unscalloped wing. Increased tension on the wing trailing edge cable reduced the abruptness of the irregularities but gave rise to high nose down pitching moments.

The effect of angle of attack on wing contour can be seen in Figures 11.3 and 11.4. The apparent asymmetry of wing panel contours at the lower angle of attack (Figure 11.4) has tentatively been determined to be the cause of the high speed right wing roll-off tendency.

#### 11.4 Interpretation of Test Results

In interpreting test results the thought should be kept in mind that the vehicle tested was no more than a pure research tool. The purpose of the test was to determine the overall feasibility and potential tactical use of a vehicle utilizing this concept for several military applications.

Though method of control, stability, performance and configuration were not optimized, twenty-five hours of test flights (1) demonstrated that the vehicle can be successfully flown, (2) provided direction in design of future vehicles to optimize a configuration for a particular application.

The test vehicle's primary control system, being fully manual, assured that all moments produced by the single lifting surface were transmitted directly to the pilot's control column and wheel. This design provided two areas of information obtainable in no other way: (1) through instantaneous pilot observation and evaluation, the aerodynamic moments were prevented from approaching or exceeding values which may cause structural failure, since the pilot's physical limitations would be reached first, signalling a requirement for corrective action; (2) the aerodynamic behavior of the flexible lifting surface could be qualitatively evaluated by the pilot as the flight envelope was expanded. The characteristics of the induced moments could be related qualitatively to the feasibility of optimizing the control system so as to satisfy existing aircraft handling quality specifications.

Since this concept is basically one of control through center of gravity movement, it follows that only two direct controls can be applied, pitch and roll, with directional control resulting as a by-product of roll control. The vehicle was flown in this configuration with two undesirable results: (1) take-off and landings in cross winds were more difficult to execute than if a primary directional control were provided; (2) pure roll control required undesirably high control forces. However, this is a problem of optimizing design and not a deficiency in the basic concept of control through movement of the center of gravity.

Quantitative data could be considered reliable only if the tests were conducted in absolutely calm air. Flights were made in light to moderately rough air. Data from these flights was useful in a qualitative sense.

Results indicate, as would be expected, that the test vehicle was quite sensitive to turbulence. Such behavior is directly related to wing loading. With

controls free, considerable control column and wheel movement were evident. This was produced by aerodynamic disturbance from motion between the wing and the platform. Effort to restrain this motion by application of control forces was uncomfortably high. Vehicle stability, however, was sufficiently strong to prevent divergent motions, as evidenced when the controls were completely released. With locked longitudinal control, the vehicle motions were of a lesser magnitude. With locked pitch control, pitching motion between the wing and platform was prevented, thereby lowering the effective center of gravity, with an associated restraining moment tending to damp wing motion in pitch. These undesirable control motions in turbulent air present a design problem that lends itself to a straightforward solution in the design of the control mechanism. Further improvement in handling qualities may be made by increasing wing loading, with a corresponding sacrifice in rate of climb and in take-off and landing speed.

Available data upon which to establish design criteria was extremely limited at the time the test vehicle was fabricated. The purpose of the test vehicle was to gather the needed data. The data, both quantitative and qualitative, which has been obtained as a result of this program may now be analyzed to provide design information which will allow optimization of flexible wing configurations for selected applications.

#### 11.5 Evaluation

The applicability of the flight test results covers a wide range, which includes manned and unmanned vehicles. The test vehicle was manned, and many problems were directly associated with handling qualities and in general control limitations as defined by human capability. This, in addition to the existence of completed and "in progress" test programs which use unmanned test vehicles employing the flexible wing, center of gravity shift control concept, suggests that applicability of results here largely concentrate on manned vehicles.

The limitations of the test vehicle were primarily associated with the control system. For manned applications, the size and weight of the vehicle used during this test program appear to be a maximum limit for acceptable control forces and gradients when considering a control system mechanically similar to the test vehicle. A control system, manually controlled, which employs an aerodynamic boost or servo for primary control, would allow vehicle size to increase, without resulting increase in control forces or gradients. In fact, a refined control system which employs a manually controlled aerodynamic boost tab or surface would require much lower control

forces than manually controlling the primary lifting surface directly. In addition, aerodynamic and inertial feedback into the control system would be negligible compared to those experienced in the test vehicle.

The test program showed that optimization of control systems for manned vehicles employing the Flexible Wing is the major area of future effort. For large vehicles of four thousand (4000) pounds gross weight or more, a powered control system is suggested. Directional control becomes a requirement for manned vehicles which must cope with cross winds during take-off and landings.

#### 11.6 Modifications

During the complete flight test history of the test vehicle, several modifications were effected, predominantly dictated by deficiencies apparent in the control system and associated control power as the testing progressed. These modifications are listed below. They include those made during the contractor's functional and safety flight test program completed prior to the initiation of the contractual flight test program.

<u>Modification</u>	<u>Program</u>	<u>Reasons</u>
1. Longitudinal control relocated from 48% keel length to 51% keel length	Contractor	Throughout the entire longitudinal trim range, the control pull force required to obtain sufficient angle of attack for flight was beyond pilot capability. It was evident that the wing cp was too far aft of the longitudinal control pivot point.
2. Wing pitch control range was reduced from $+3^{\circ} - +30^{\circ}$ to $+21^{\circ} - +30^{\circ}$	Contractor	The above mentioned modification brought the longitudinal control force range within the trim capability of the test bed. However, the existing gear ratio between longitudinal control column travel and wing travel was such that the force gradient was unacceptably steep. This modification brought the force gradient within acceptable limits.

<u>Modification</u>	<u>Program</u>	<u>Reasons</u>
3. Lateral control wing attach points moved from area of pitch control pivot point to wing spreader bar area.	Contractor	Response to lateral control inputs was very poor. Ground tests under static loading simulating flight loading revealed loss of 75% of lateral control input through system deflection and stretch.
4. Rudder installation	Contractor	High lateral force gradients and difficulty during cross wind take-off and landings suggested the desirability of a rudder to: (1) reduce roll control forces by using the rolling moment produced by side slip, (2) provide directional control in cross winds.
5. Larger engine	Army	Higher drag than predicted by early NASA wind tunnel data was apparent. This produced insufficient excess engine power for adequate climb capability. Average rate of climb with the original 100 HP engine was 100 fpm or less. The new engine of 185 HP provided rates of climb in the order of 300 fpm.
6. Scallop wing trailing edge	Army	A considerable amount of trailing edge flutter existed during flight. Approximately 1.5 to 2 feet of the wing at the trailing edge was fluttering. Removal of a portion of the wing to a maximum depth of 14" at the center of the semi-span and curving to tangency at the leading edge and keel ends reduced 60% to 70% of the flutter area.

<u>Modification</u>	<u>Program</u>	<u>Reasons</u>
7. Replace wing membrane and relocate longitudinal control pivot point from 51% keel length position to 50% position.	Army	The original wing experienced peeling of the Mylar coating from the nylon base material primarily due to flutter. The control pivot point was moved to increase nose down pitching control power.
8. Addition of trailing edge tension cable.	Army	The modification above was insufficient to provide adequate nose down pitching power and trim, primarily because of the large apparent difference in wing characteristics which caused a forward shift in cp. Tension adjustments in the trailing edge provided satisfactory pitch trimming to bring trimmed flight conditions within the normal trim range of the vehicle.
9. Addition of trailing edge battens	Army	Low frequency large amplitude trailing edge flutter resulting from the tension in the trailing edge, produced feedback into the control column. The battens rectified this condition by eliminating flutter.
10. Scallop wing trailing edge.	Army	The wing under flight loading conditions showed some large discontinuities in the area just forward of the trailing edge and inboard. Scalloping was effected to produce chordwise tension in the area of the discontinuity. The modification was only partially successful.

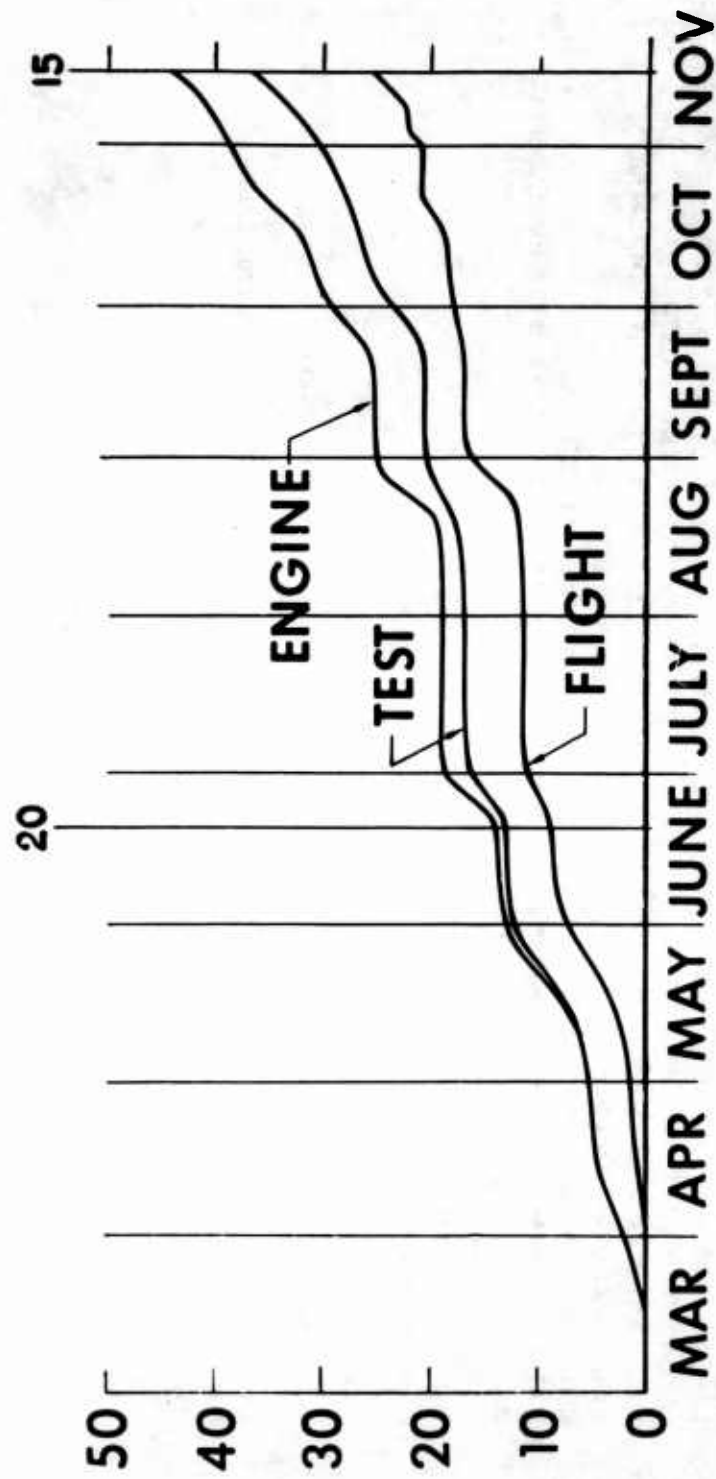

Figure 11.1 History of Testing Time

DIRECTIONAL CONTROL, POWER ON  
 DIRECTIONAL CONTROL, POWER OFF  
 LATERAL CONTROL  
 LATERAL/DIRECTIONAL CONTROL  
 LONG. TRIM CHANGE WITH SPEED  
 LONG. TRIM CHANGE WITH POWER  
 SPEED DECAY RATE VERSUS FLARE  
 STATIC LONG. STAB. , STICK-FIXED, POWER OFF  
 STATIC LONG. STAB. , STICK-FREE, POWER OFF  
 STATIC LONG. STAB. , STICK-FIXED, POWER ON  
 STATIC LONG. STAB. , STICK-FREE, POWER ON  
 TRIM SPEED BAND  
 LONG PERIOD LONG. DYNAMIC STAB.  
 SHORT PERIOD LONG. DYNAMIC STAB. - "ELEVATOR"  
 SHORT PERIOD LONG. DYNAMIC STAB. - AIRPLANE  
 \* LONG. STAB. TESTS AT SECONDARY ALT.  
 AILERON S-TURNS  
 SPIRAL STABILITY  
 \* NORMAL STALLS  
 \* ACCELERATED STALLS

MAXIMUM SPEED DETERMINATION  
 TAKE-OFF PERFORMANCE  
 AIRSPEED FOR BEST RATE OF CLIMB  
 AIRSPEED FOR BEST ANGLE OF CLIMB  
 \* SECONDARY ALT. FOR BEST RATE OF CLIMB SPEED  
 AIRSPEED FOR BEST L/D  
 AIRSPEED FOR BEST SINK RATE  
 \* SECONDARY ALT. FOR BEST L/D AND SINK RATE AIRSPEEDS

GROUND RUN ACCELERATION  
 LONGITUDINAL TRIM, STICK-FIXED  
 PEDAL AUGMENTED LAT. CONT. SYSTEM  
 LONG. CHARACTERISTICS W/TRAILING EDGE CABLE  
 CHARACTERISTICS OF SCALLOPED WING  
 LATERAL TRIM WITH TRAILING EDGE CABLE  
 SIDESLIP CAPABILITIES

\* ELIMINATED

Figure 11.2 Test Objectives

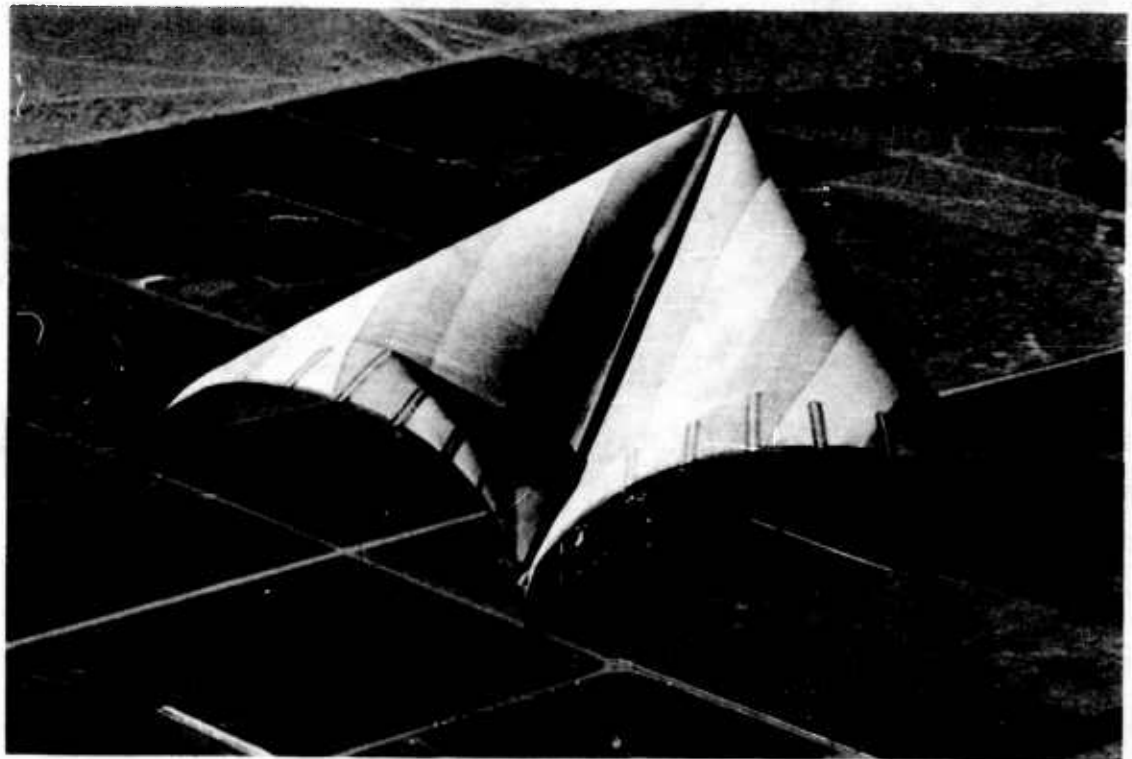

**Figure 11.3 Typical In-Flight Wing Contour (33 MPH IAS)**



Figure 11.4 Typical In-Flight Wing Contour (53 MPH IAS)

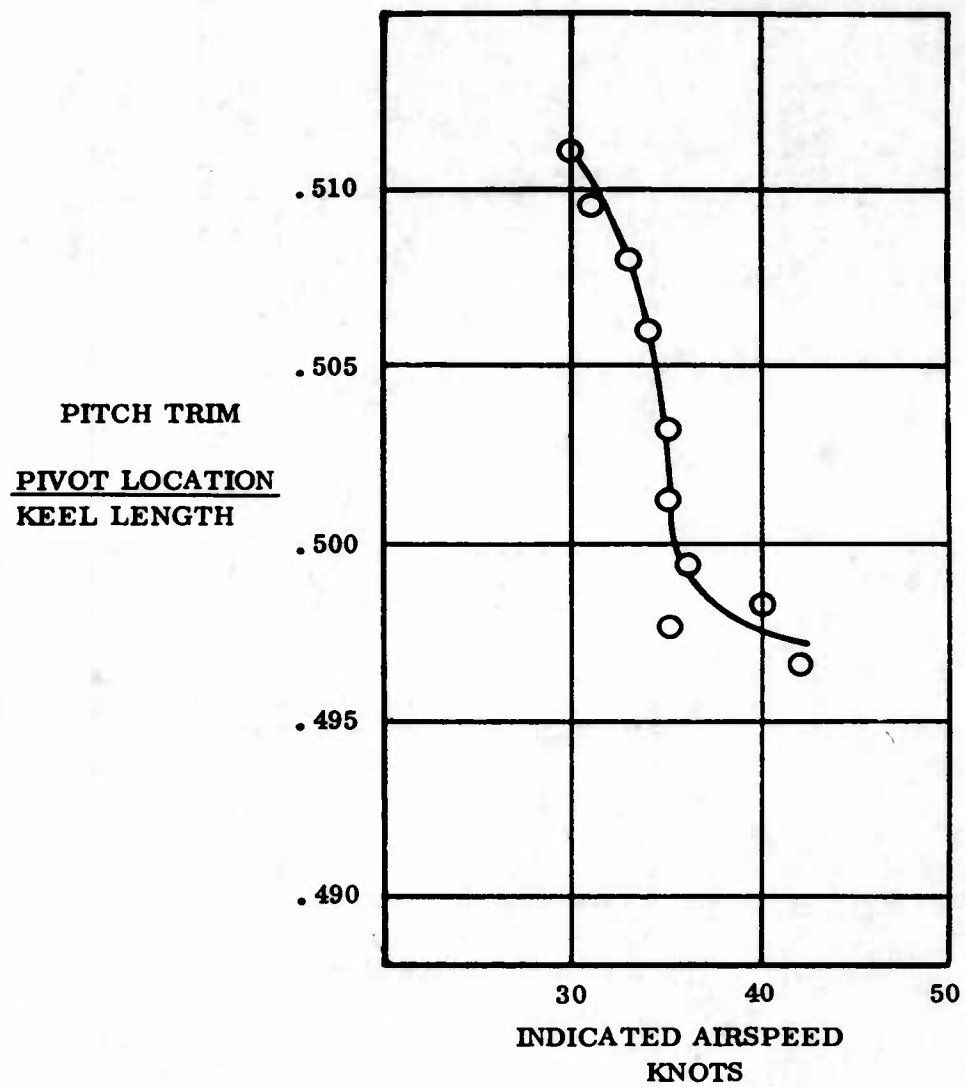

**Figure 11.5 Longitudinal Trimmability (Unscalped Wing)**

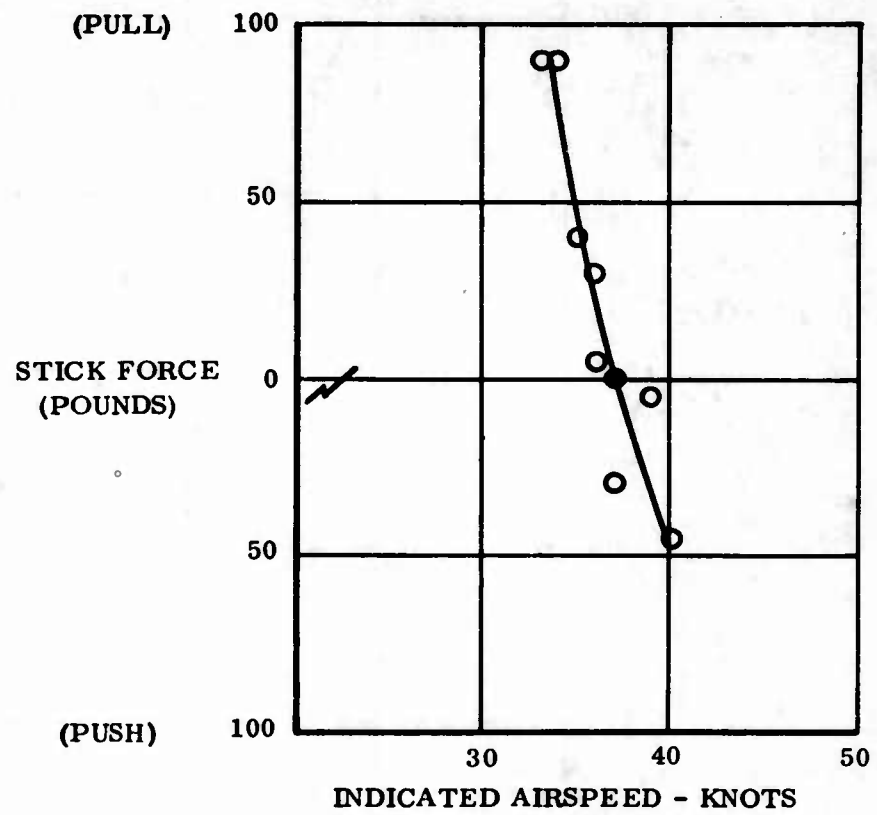

Figure 11.6 Static Longitudinal Stability Trim Speed - 37 Knots IAS

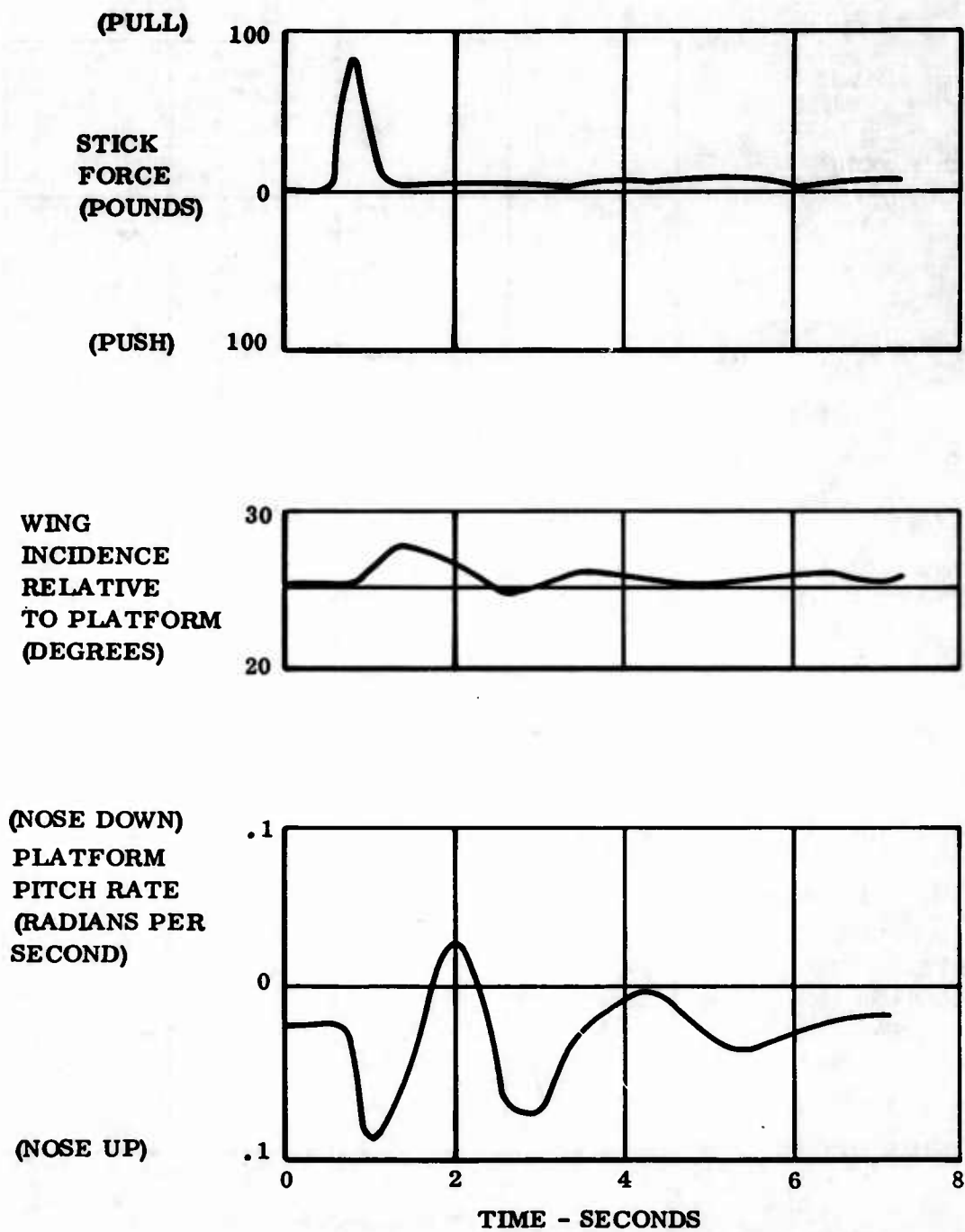

Figure 11.7 Longitudinal Dynamic Stability (Stick Free) Pull Pulse

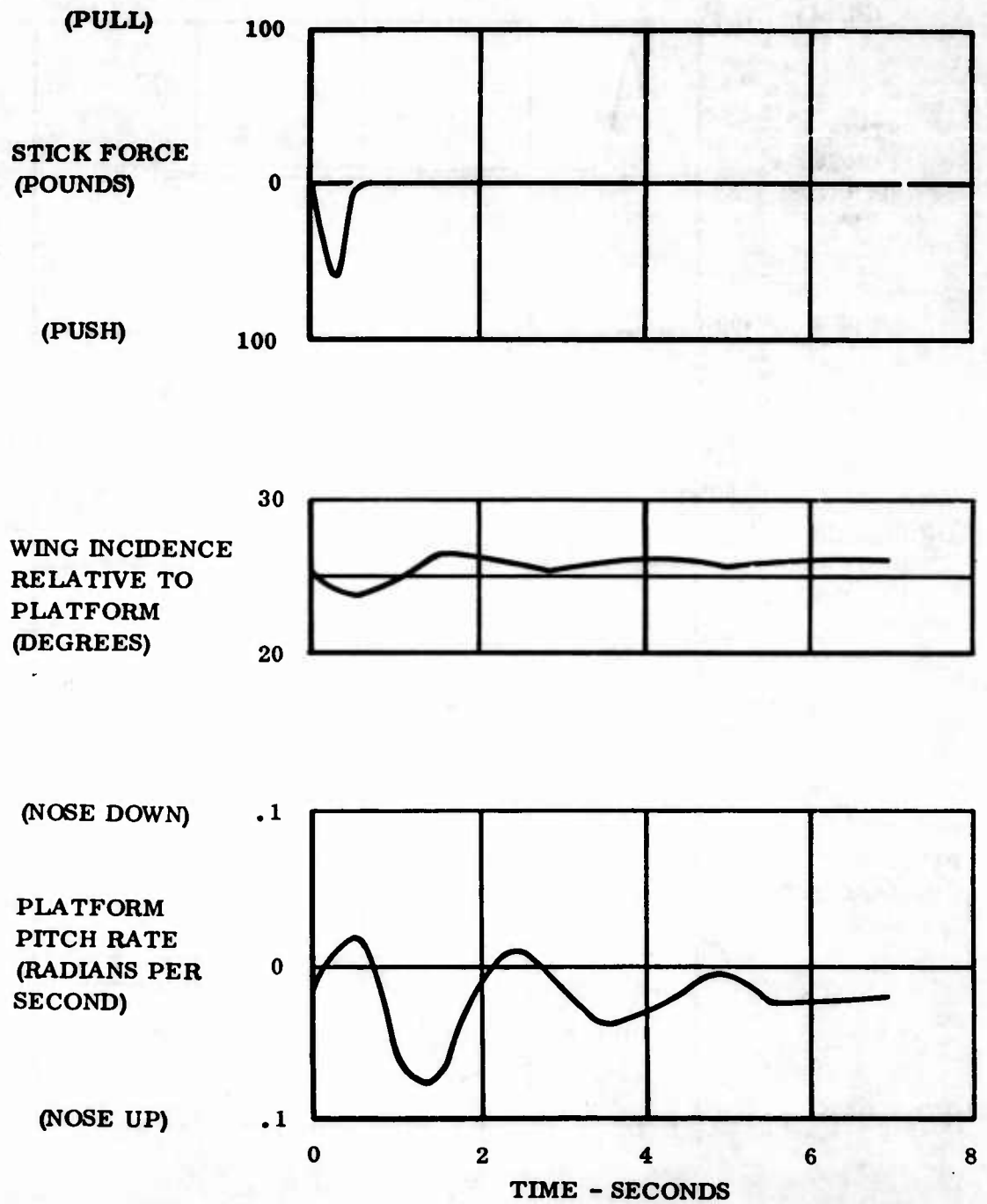

Figure 11.8 Longitudinal Dynamic Stability (Stick Free) Push Pulse

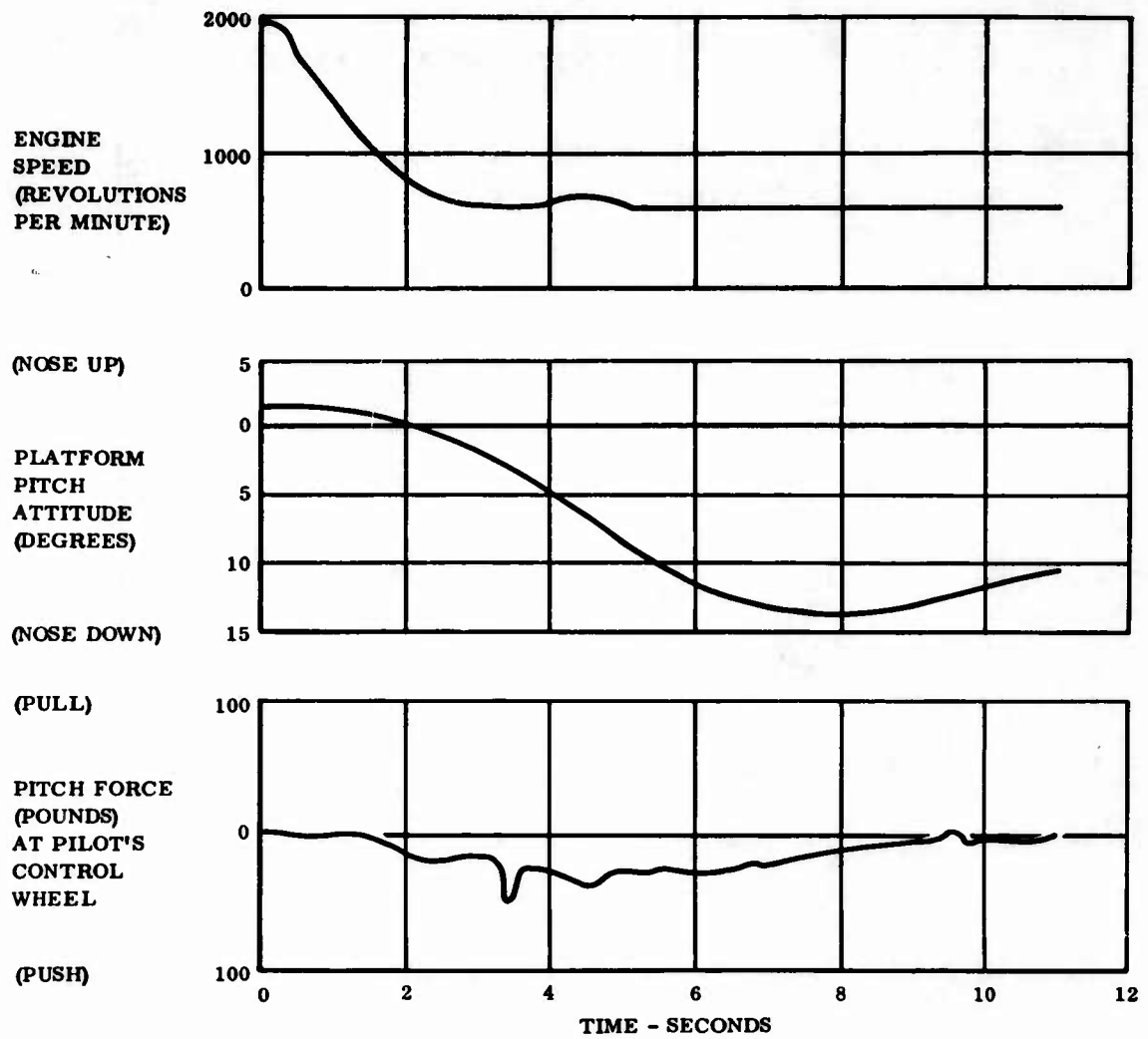

Figure 11.9 Effect of Rapid Power Reduction on Platform Attitude

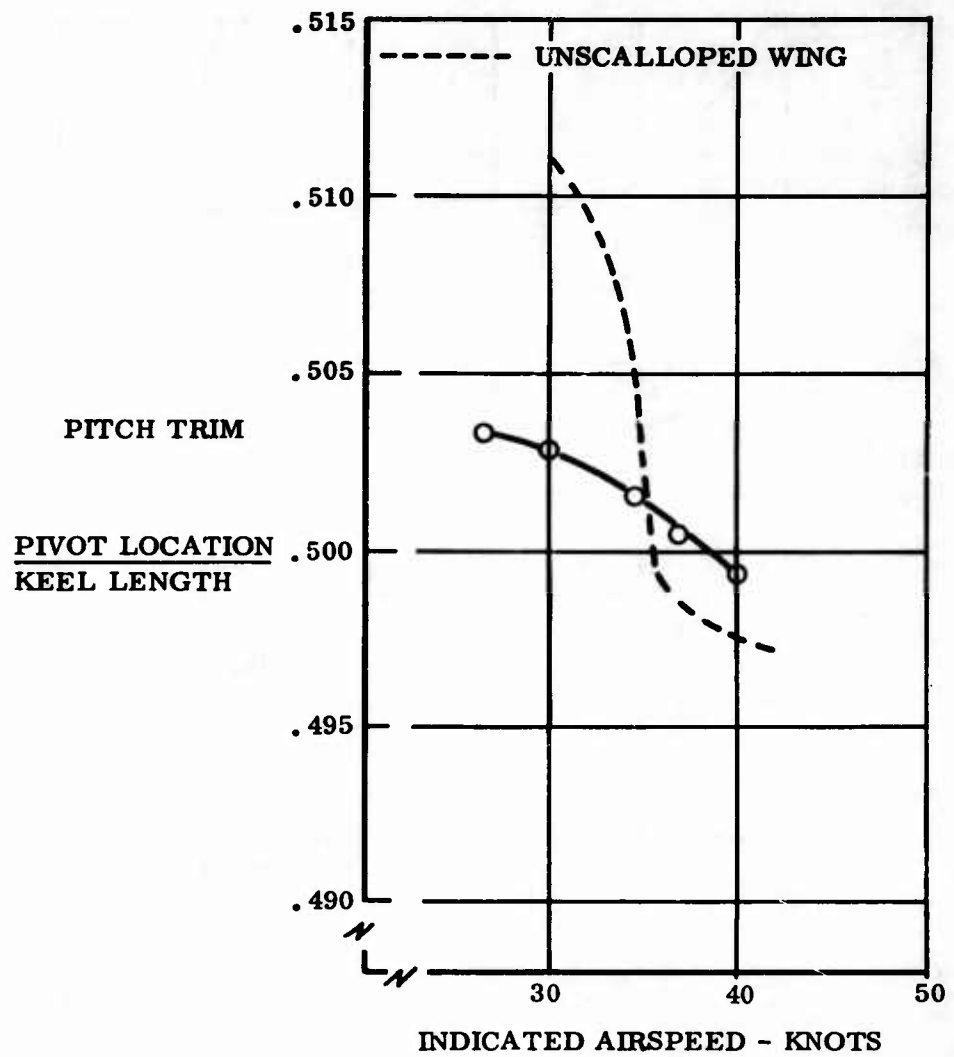

Figure 11.10 Longitudinal Trimmability (Scalloped Wing)

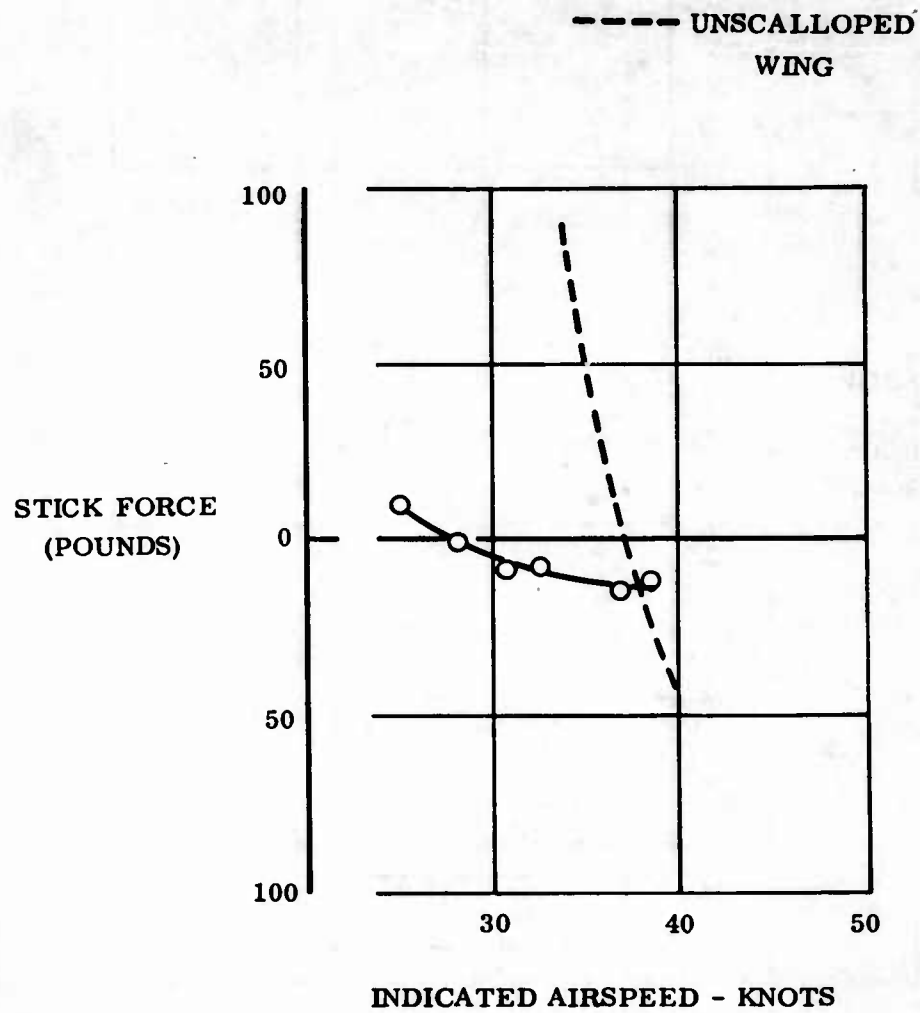

Figure 11.11 Static Longitudinal Stability (Scalloped Wing) Trim Speed  
28 Knots IAS

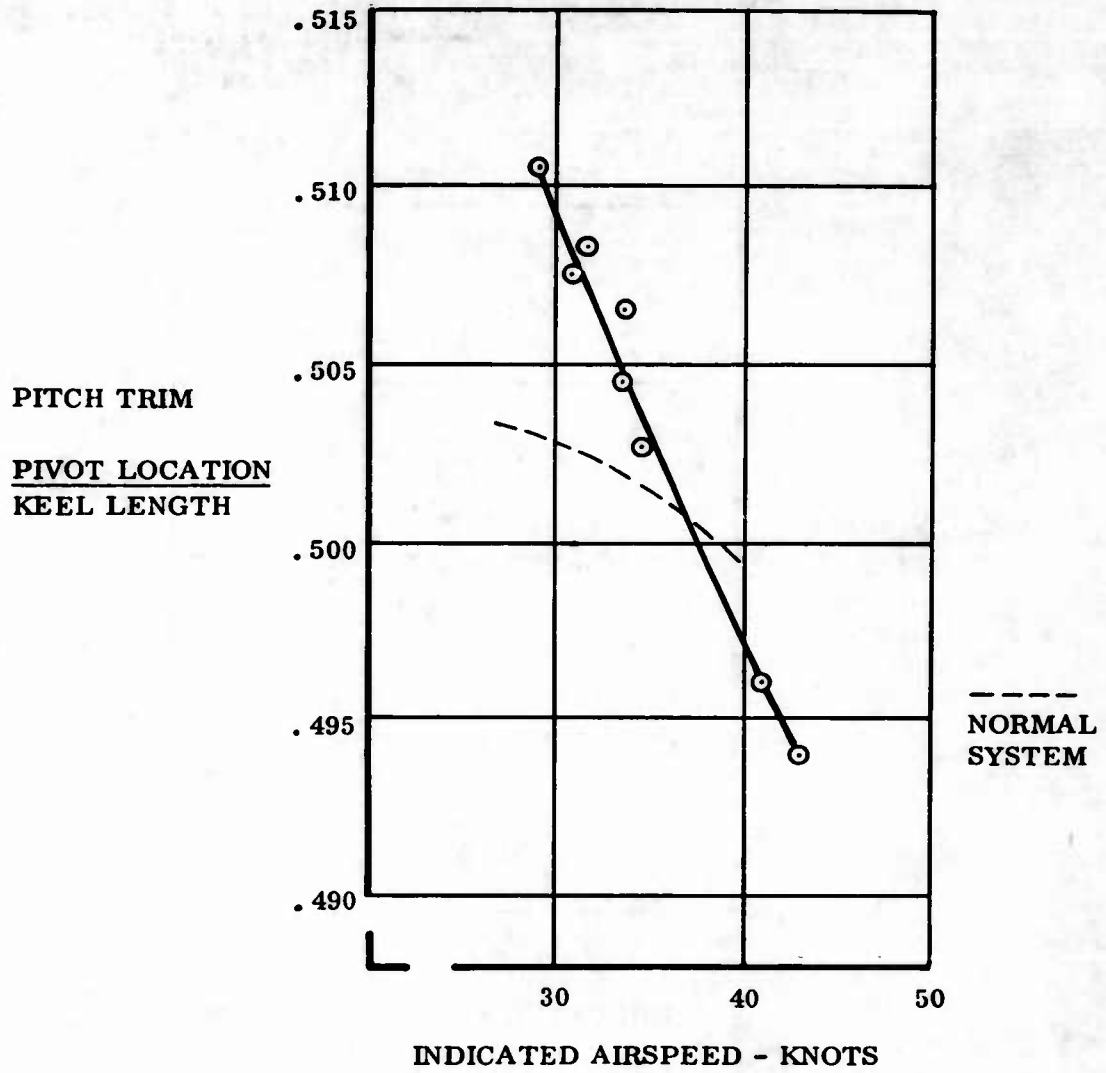

Figure 11.12 Longitudinal Trimmability (Scalloped Wing) with Simulated Irreversible Longitudinal Control System

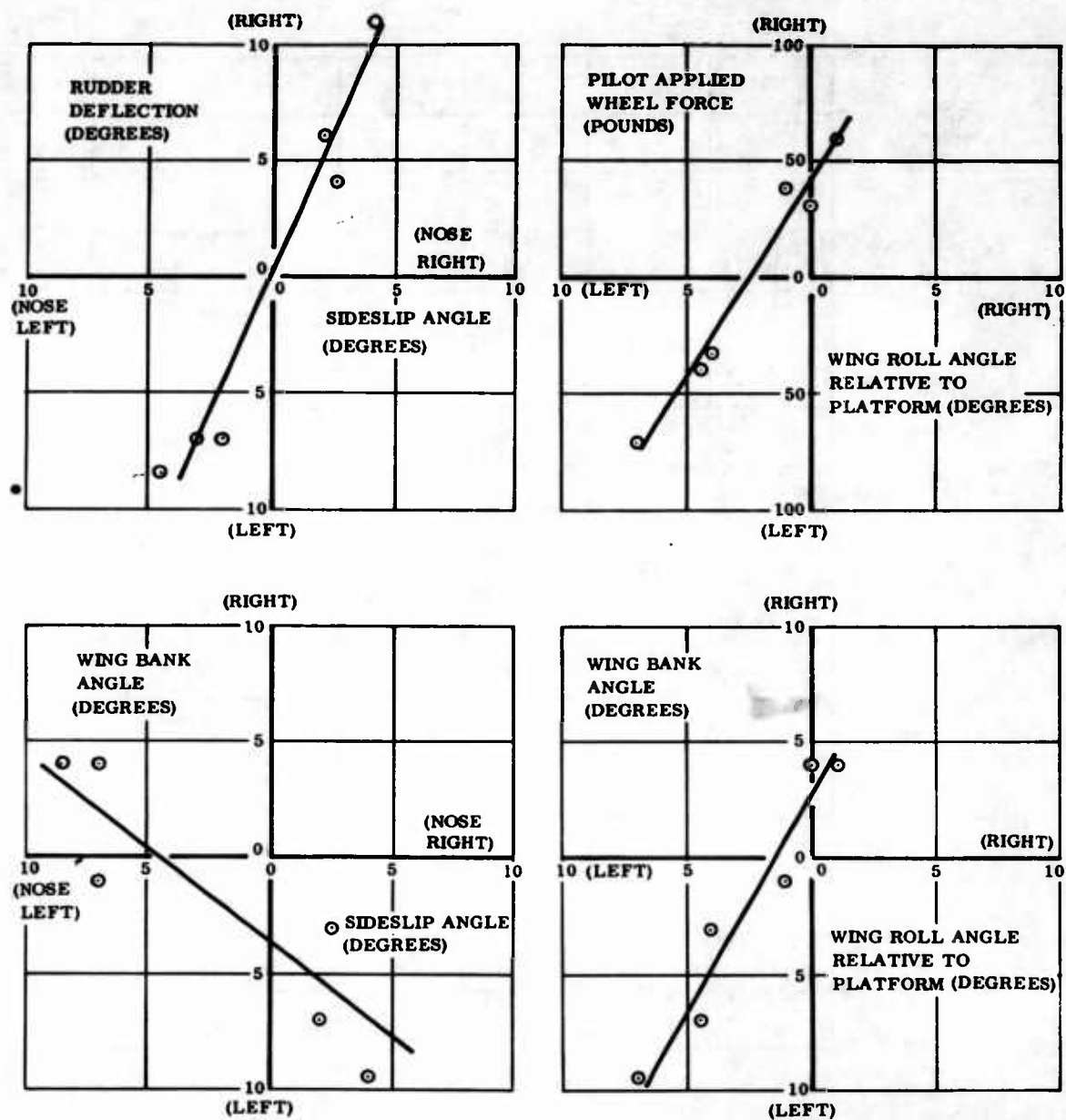

Figure 11.13 Sideslip Characteristics

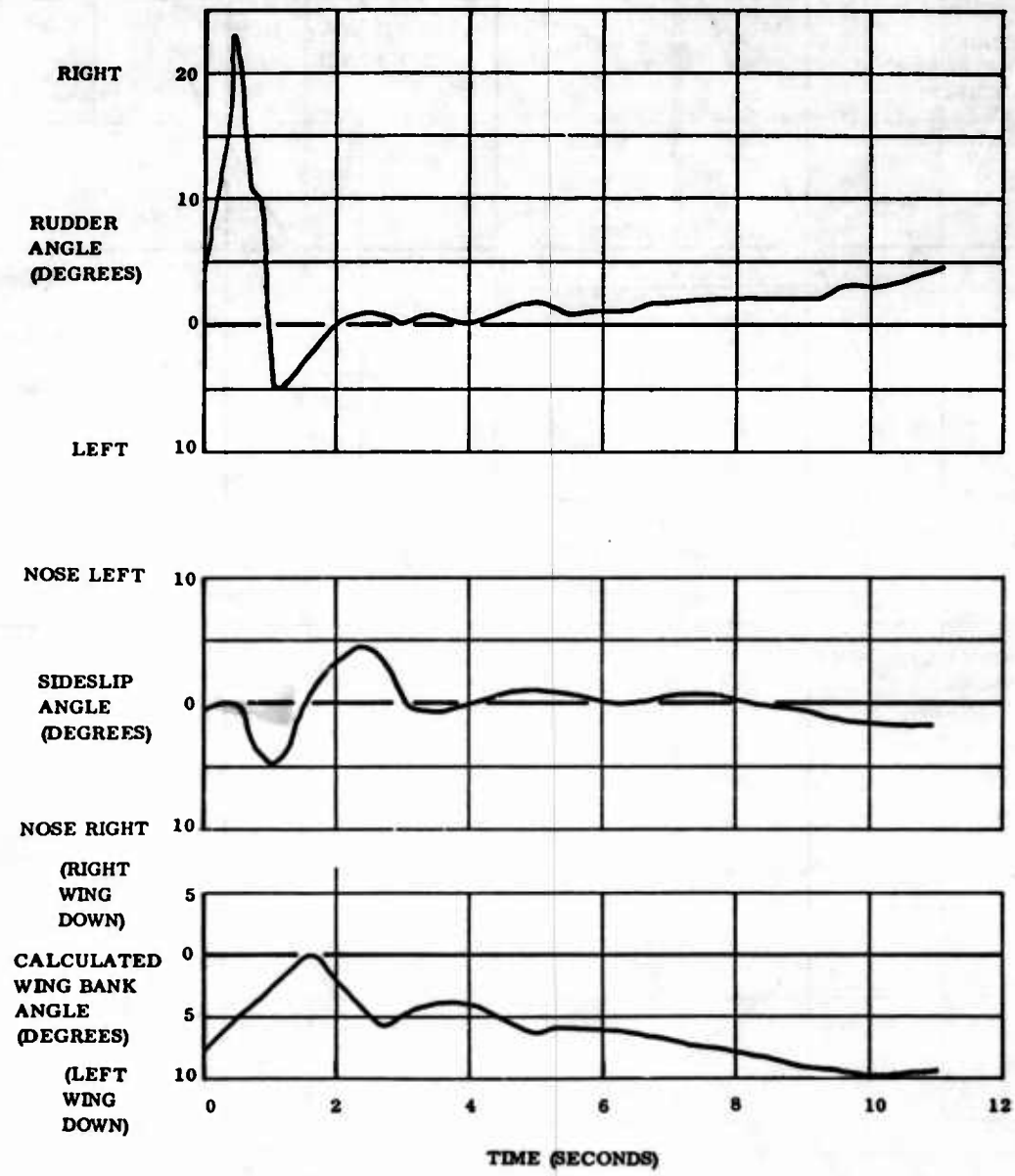

Figure 11.14 Dynamic Lateral/Directional Stability (Right Rudder Pulse)

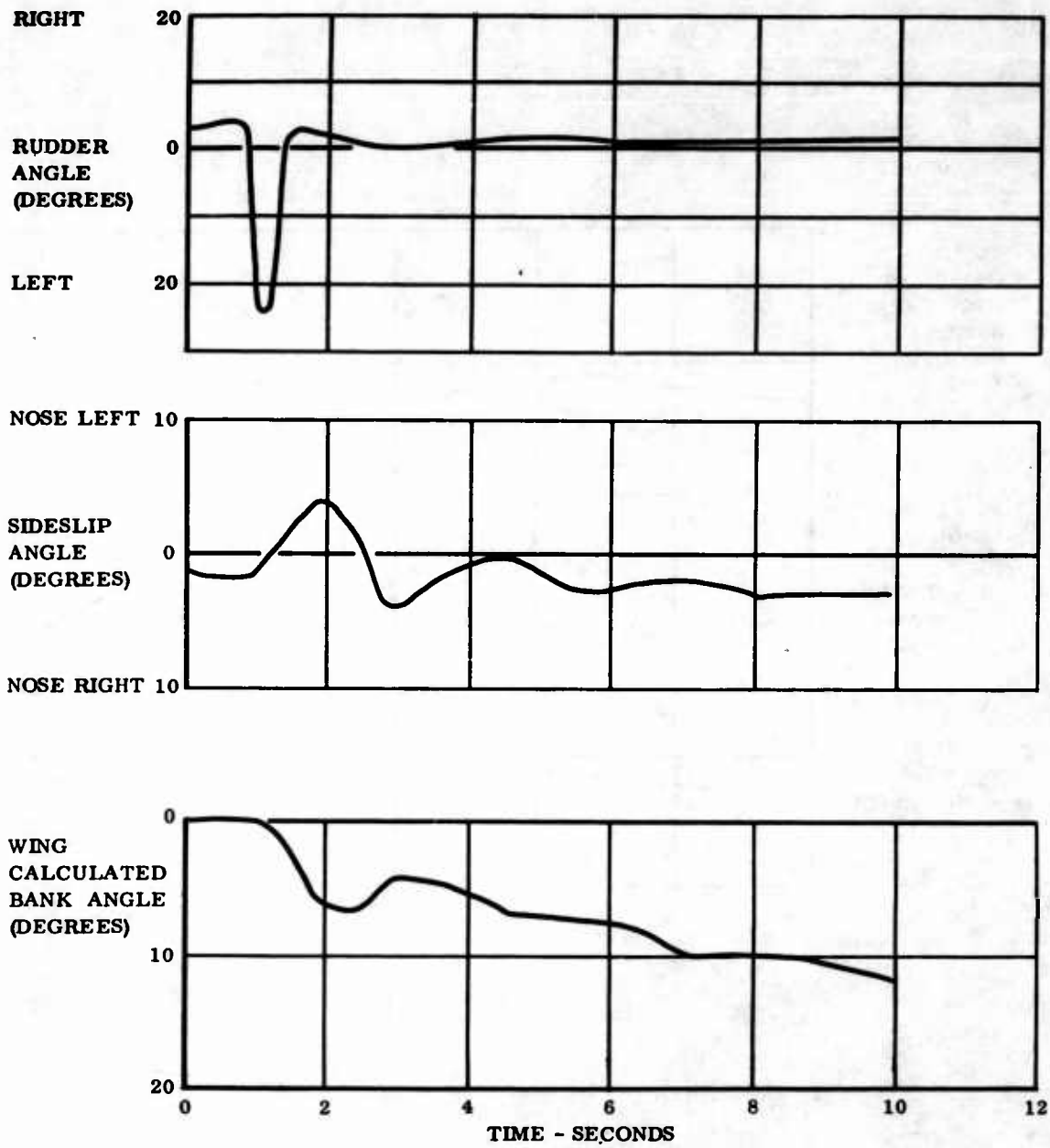

Figure 11.15 Dynamic Lateral/Directional Stability (Left Rudder Pulse)

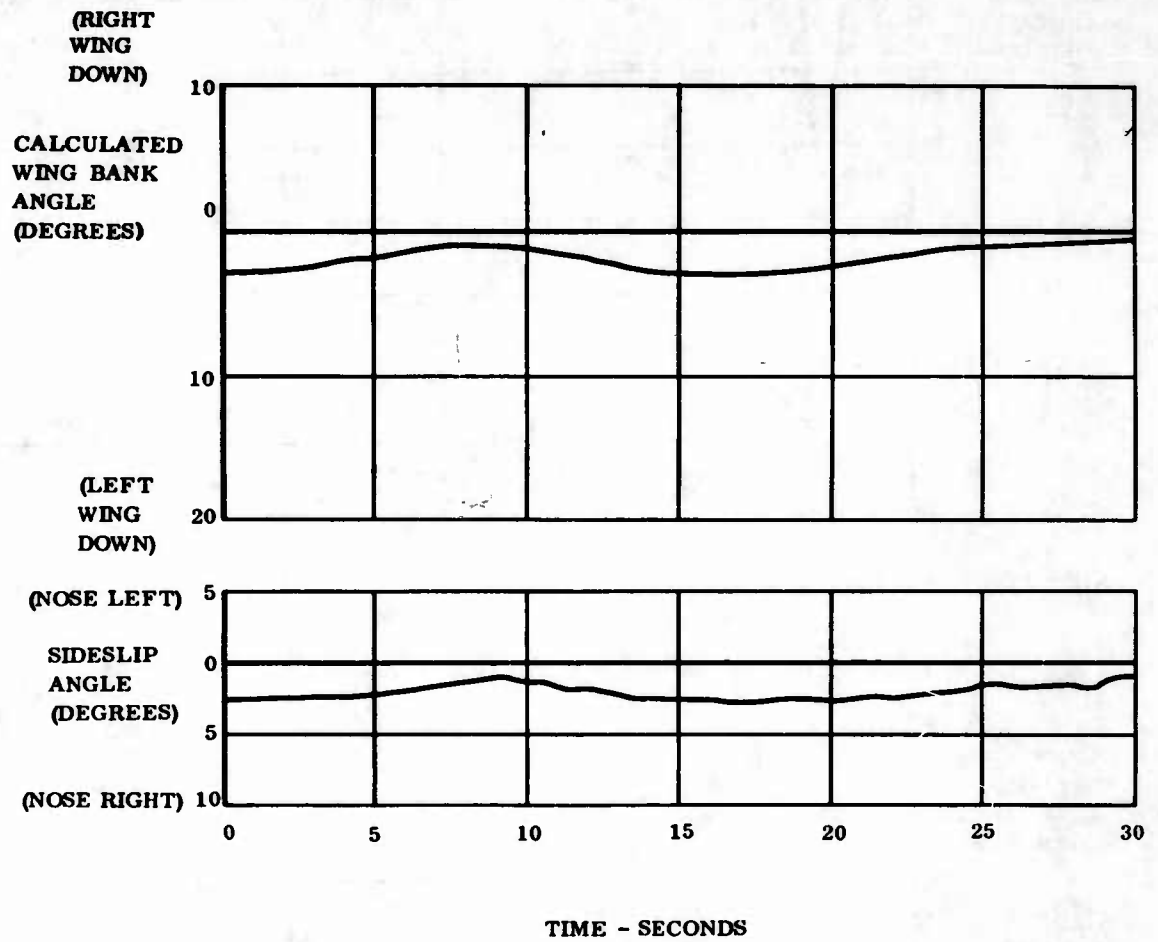

Figure 11.16 Spiral Stability - Right Bank

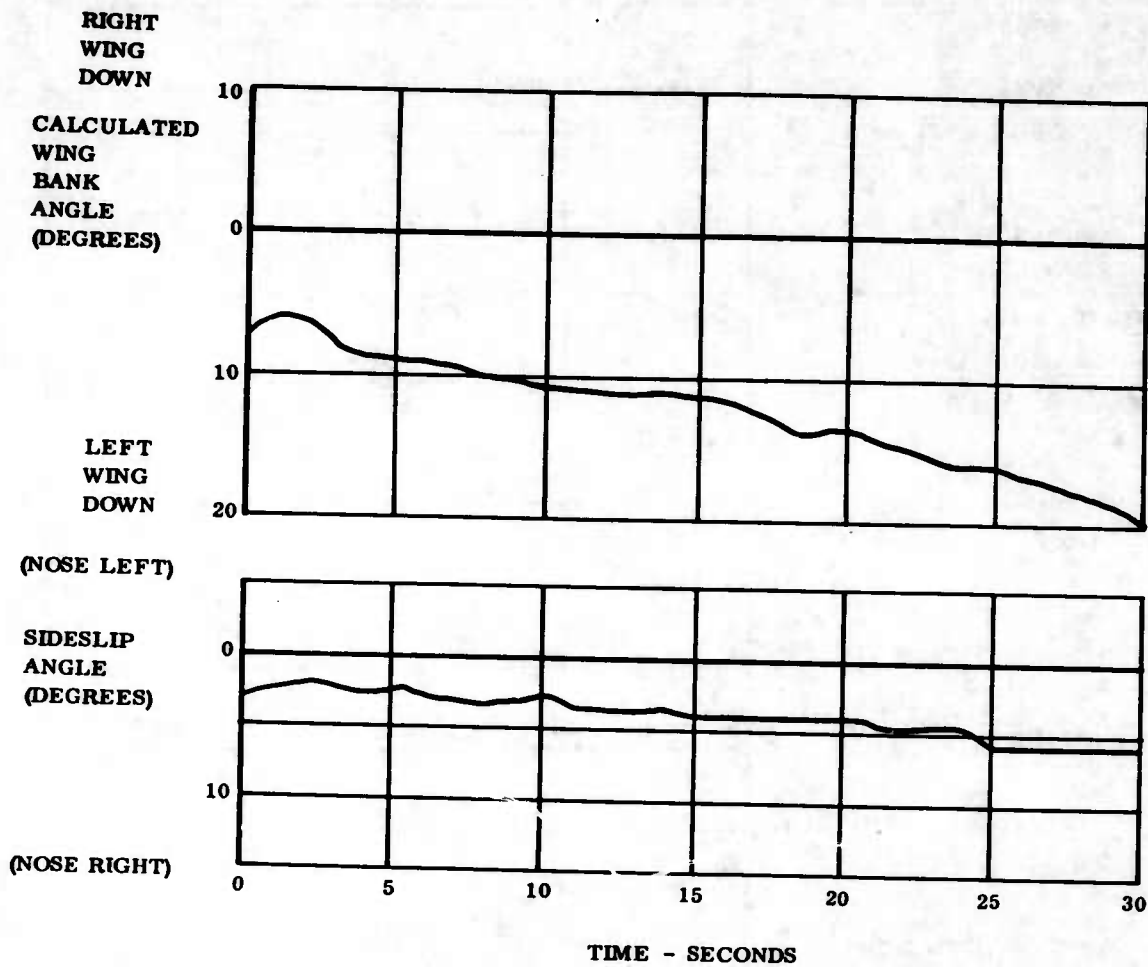

Figure 11.17 Spiral Stability - Left Bank

(RIGHT)

RUDDER  
DEFLECTION

(DEGREES)

(LEFT)

(NOSE LEFT)

SIDESLIP  
ANGLE

(DEGREES)

(NOSE RIGHT)

(RIGHT)

WING ROLL ANGLE  
RELATIVE TO  
PLATFORM

DEGREES

(LEFT)

(RIGHT)

PILOT APPLIED  
ROLL CONTROL  
FORCE

POUNDS

(LEFT)

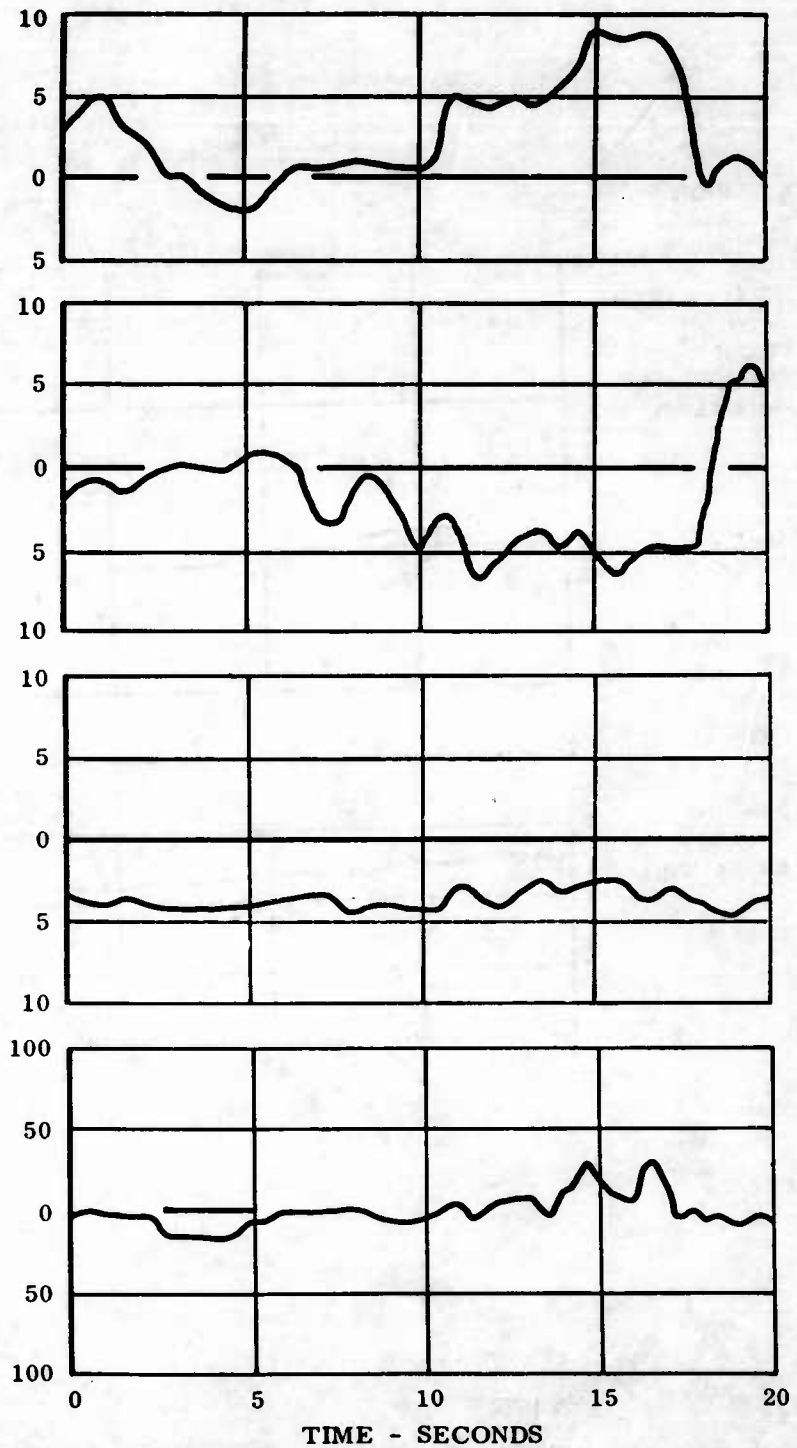

Figure 11.18 Time History of Coordinated Turn to Left

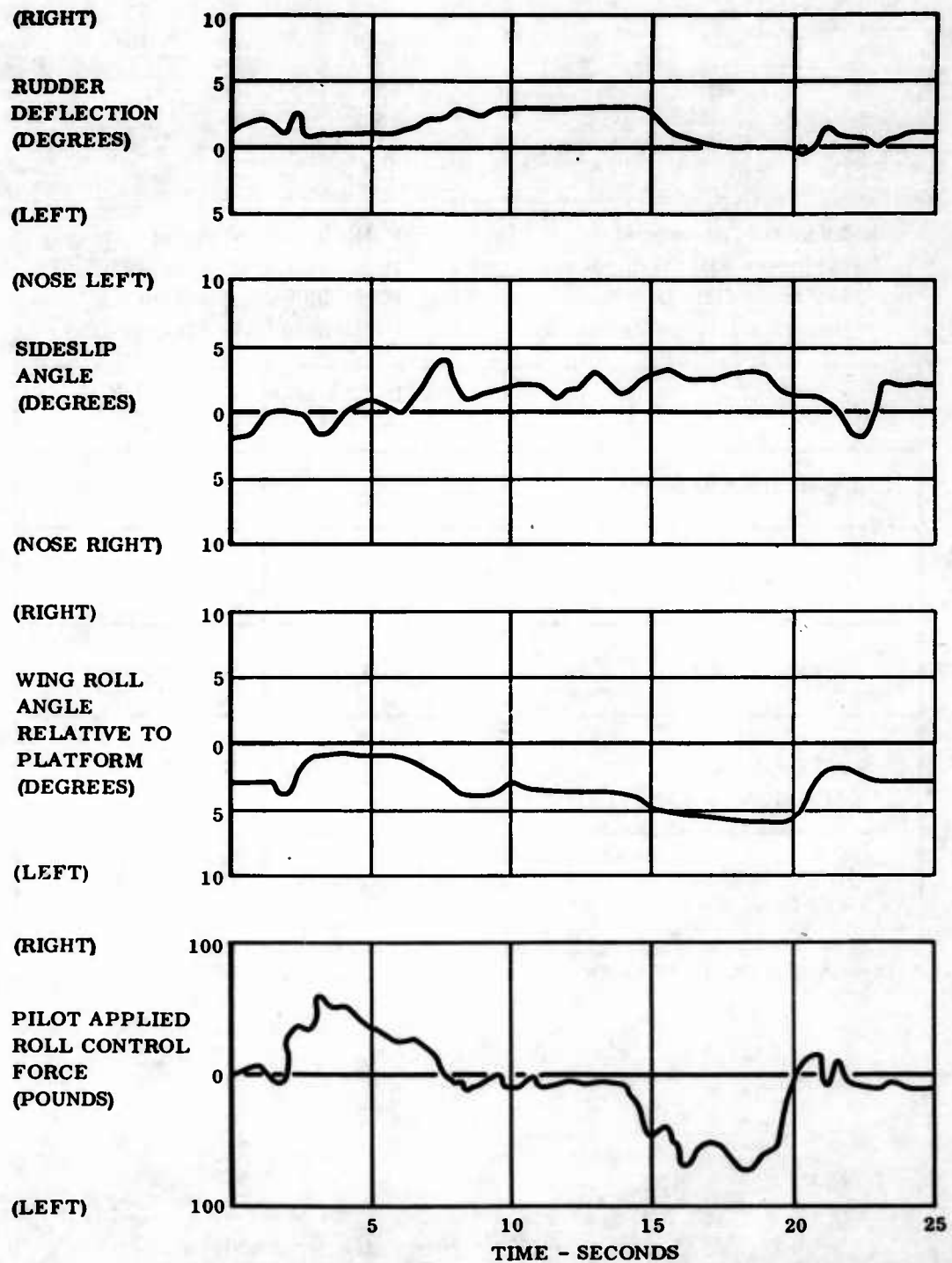

Figure 11.19 Time History of Right Turn Using Lateral Control Input Only

### SPEEDS

Minimum Attempted 32 M. P. H. Indicated Airspeed  
\* Maximum Attained 54 M. P. H. Indicated Airspeed  
Maximum Rate of Climb 38 M. P. H. Indicated Airspeed  
Minimum Rate of Descent 37 M. P. H. Indicated Airspeed

	CONTINENTAL ENGINE	LYCOMING ENGINE
TAKE-OFF DISTANCE	700 FEET	360 FEET
LANDING RUN	200 FEET	200 FEET
RATE OF CLIMB	100 FEET/MIN.	290 FEET/MIN.
RATE OF DESCENT (MINIMUM @ IDLE THRUST)	600 FEET/MIN.	600 FEET/MIN.
GROSS WEIGHT (APPROXIMATE)	1450	1800

\* Limited By Right Wing Roll-Off Characteristic

Figure 11.20 General Performance Information

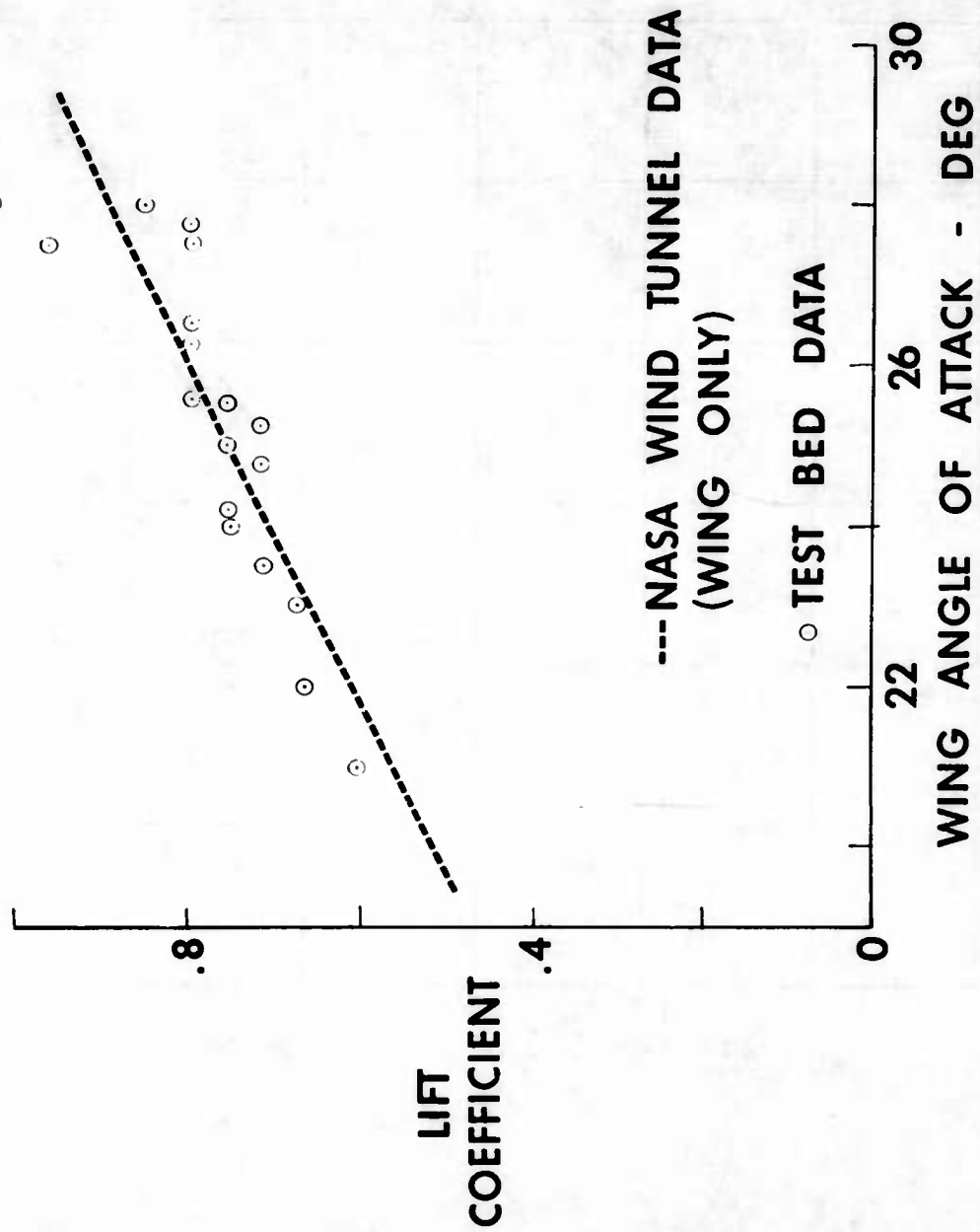

Figure 11.21 Lift Variation with Angle of Attack

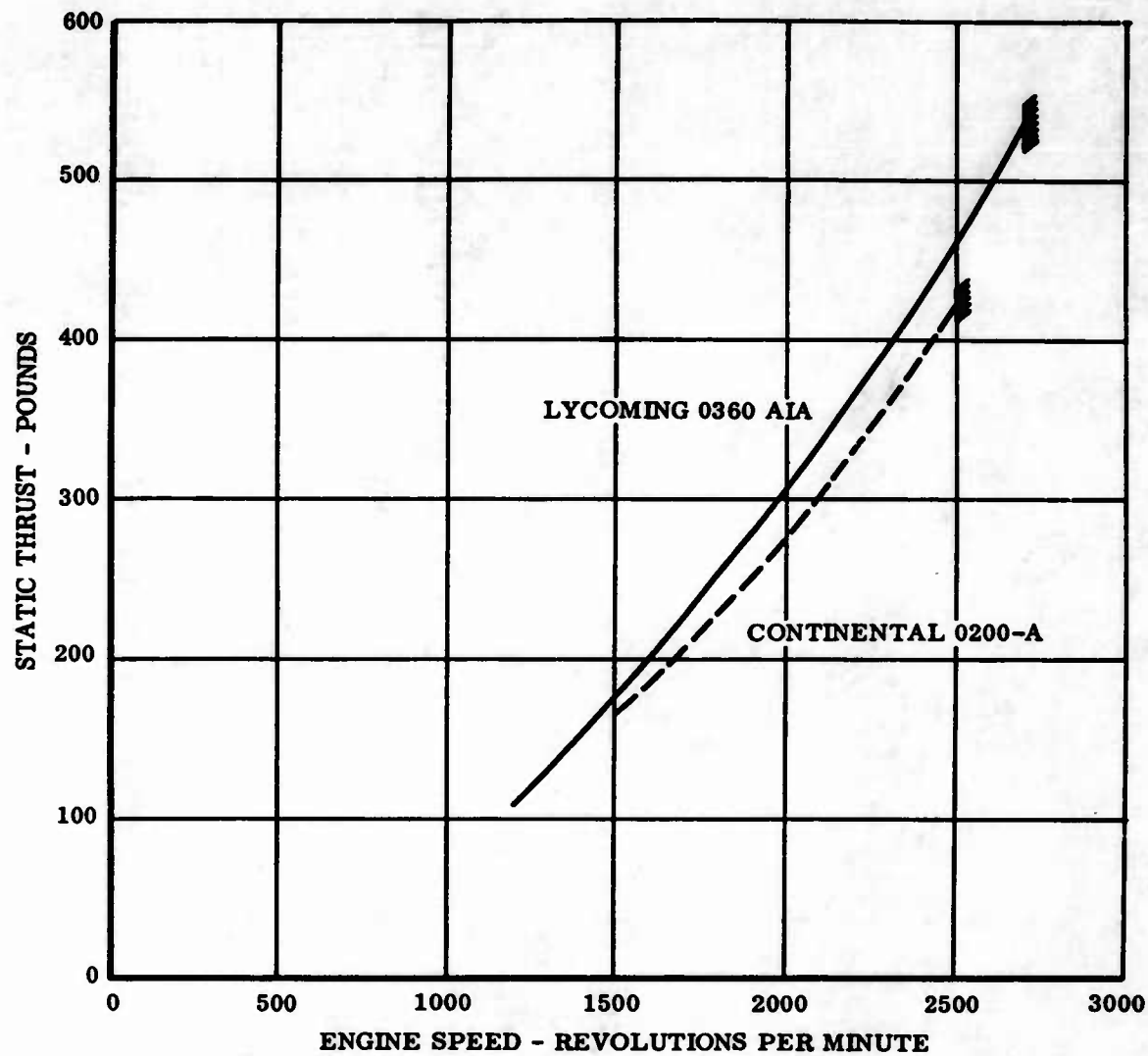

Figure 11. 22 Results of Static Thrust Tests

## 12.0 BIBLIOGRAPHY

Ref. No.	Title
1	Doyle, G. B. " <u>Pilot Techniques for Stability and Control Testing</u> ," Naval Air Test Center, Patuxent River, Maryland, 1 June 1954.
2	MIL-A-8861
3	Bruhn, E. F., " <u>Analysis and Design of Airplane Structures</u> " Sixth Edition, Tri-State Offset Co., Cincinnati, Ohio, October 1947.
4	Cassidy, W. J. " <u>Structures Manual</u> " Ryan Aeronautical Co., San Diego, California, 1 August 1957.

## 13.0 APPENDIX

### 13.1 Flight Test Log

A compilation of the flight test reports covering the tests conducted during the program is presented. The first ten tests, which precede the installation of the new wing, are summarized into one report.

The position of the wing pivot point was calibrated to an arbitrary scale on the pilot's instrument panel. The individual flight test reports make reference to this arbitrary scale. Figure 13.1 is presented so that these trim numbers may be reduced to a more meaningful scale, i. e., pivot location in percent of keel length.

Flight Test Report, Army 1 through 10

#### Objectives:

1. Evaluate control characteristics of new rudder installation.
  - a. Rudder alone
  - b. Wing tilt alone
  - c. Coordinated use of rudder and wing tilt.
2. Evaluate mechanical interconnect of rudder and wing tilt controls for 3 different mechanical advantages of wing tilt.
3. Evaluate speed-power relationship while in and out of ground effect.
4. Evaluate flaring capabilities, power off.
5. Evaluate rate of climb and rate of descent performance with 100 HP engine.

6. Evaluate rate of climb vs. airspeed, power off sink rates at various airspeeds, flare capabilities, trim setting vs. speed for zero stick forces.

7. Evaluate effect of scalloping wing trailing edge to reduce membrane flutter.

**Results:**

1. Lateral response to control inputs and lateral control force are greatly improved as a result of rudder installation.

2. Interconnection of rudder and wing tilt controls does not permit the flexibility of control manipulation necessary during take-off and landing in cross winds.

3. While within ground effect (with one span length of 40 ft. above ground) a 3-5 mph higher speed for a given power setting was obtained than when out of ground effect.

4. At approximately 200 feet above ground level, a flare was effected from steady state velocity of 40 mph to 32 mph during which rate of descent was reduced to approximately zero. Rapid build up in rate of descent was seen immediately upon reaching 32 mph. A time period of 2-3 seconds was covered in the speed change from 40 to 32 mph.

5. Critical power available and relatively turbulent air prevent accurate steady state conditions. However, 37-38 mph appears to be best speed for maximum rate of climb. Thirty mph appears to be the speed for minimum sink rate which is 590 fpm for a gross wt. of 1500 lbs.

6. Rate of climb with the new engine installation was 300 fpm at best climb speed which was 38 mph. Minimum sink rate of 600 fpm was obtained at 37-38 mph. Speed range within which stick force could be trimmed steady state to zero was 40 mph to 32 mph. The center of pressure of the wing was shifted sufficiently far forward as a result of scalloping the wing trailing edge to prevent trimming to zero stick force. It was possible to achieve a very slight negative flight path angle with trim

**full nose down and control column full forward with partial power applied  
to remain airborne at approximately 35 mph.**

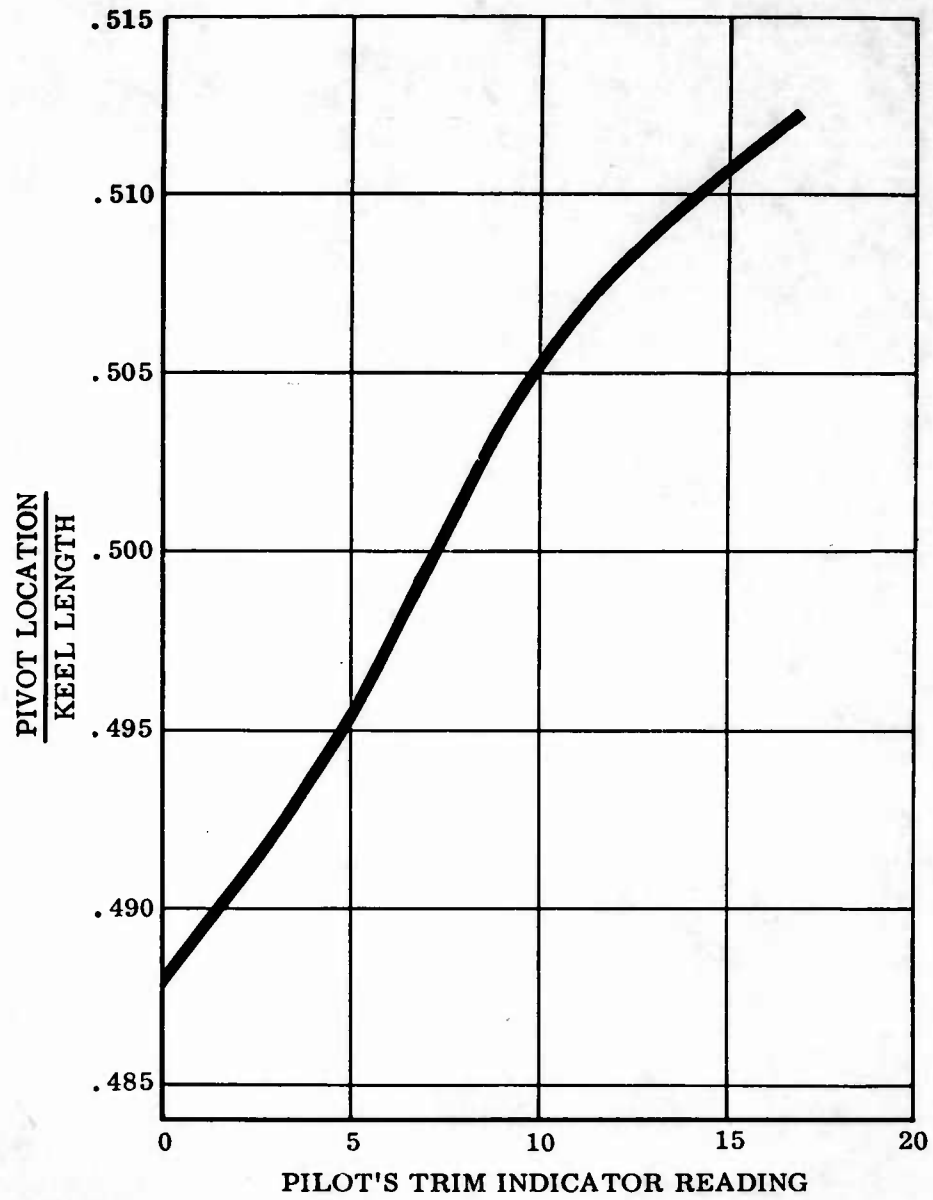

Figure 13.1 Longitudinal Trim Indicator Calibration

FLIGHT TEST REPORT ARMY NO. 11  
FLEX-WING MANNED FLIGHT VEHICLE N140N

- Objectives:** Investigate possible changes in handling characteristics as a result of recent modifications. (New wing material and aft displacement of wing 3 1/4 inches).
- Results:** Handling characteristics unacceptable. With full nose down trim, a stick push force of 135 pounds was necessary to prevent the test bed from taking off during taxi at 37 M. P. H. and 2100 RPM.
- Description:** The test was conducted at Brown Field, San Diego on September 20, 1961 at 7:45 A. M. Wind velocity was variable South to North West 4 knots and air temperature was 68°F.

Five taxi runs were made starting with full nose down trim and 1800 RPM, and increasing RPM in 100 increments on each run. During run 4, (2100 RPM) the test bed became airborne at 37 M. P. H. IAS despite full nose down trim and 135 pounds stick push force. It was necessary to reduce engine RPM to return test bed to runway. An altitude of approximately 20 feet was reached during this lift-off. Run 5 was a rerun of run 4 to gain oscillograph data and to demonstrate that the test bed could return to runway without reducing power. The test was terminated at 8:10 A. M.

**Data:** Records

26 channel oscillograph data was taken for short time intervals during the "taxi" runs in addition to external cine coverage of complete test bed and gun camera coverage of aft starboard lower trailing edge of wing.

Observations

Observers present remarked as to the "fullness" of the forward portion of this "new wing" as compared to the "old one". A full

9-26-61

span "cusp" at the trailing edge was observed and estimated at 6 inches width by the writer. Comments of "less flutter" were also made.

Pilot Reports

Run	RPM	IAS	Trim	Remarks
1	1800	30	F. N. D.	(Forward stick force
2	1900	32	F. N. D.	(required through stick
3	2000	34	F. N. D.	(position range
4	2100	37	F. N. D.	(Test bed becomes airborne
5	2100	36	F. N. D.	(required power reduction (to return to runway

Remarks:

It would appear that the aerodynamic center of pressure of this "new wing" has moved forward thereby producing nose up moments that exceed the effect of moving the wing 3 1/4" aft. This new shape of the wing could be the result of more stretch in the material or the fact that the seams now run streamwise rather than spanwise.

It was decided to attach a "boltrope" to the trailing edge to produce compensating nose down moments. The boltrope tension could be varied to achieve the desired effect.

P. D. Bartola

**FLIGHT TEST REPORT ARMY NO. 12**  
**FLEX-WING MANNED FLIGHT VEHICLE N140N**

- Objectives:** Investigate effects of wing trailing edge "boltrope" on test bed longitudinal control.
- Results:** Boltrope highly effective in producing nose down moments, but also produces 30 pound stick force oscillations unacceptable to pilot.
- Description:** The test was conducted at Brown Field, San Diego on September 25, 1961 at 8:15 A.M. A 45 degree crosswind of approximately 5 knots was present throughout the test.

Seventeen "taxi" runs were made varying trim position and engine RPM for three different boltrope "tension positions". At each of the boltrope positions the initial run was with nose down trim which was reduced on successive runs depending on stick forces.

The initial boltrope position of 2 1/2 inches per wing panel represents a total for shortening of the trailing edge of 5 inches. Runs 1 - 7 were made in this position. During run 6, with trim indicator at 12 (6.5" Fwd.) and 2000 RPM the test bed became airborne for short interval with a stick force of 70 pounds pull. Pilot reported "bumping" sensation in stick such as a rotating eccentric might produce.

Boltrope tension position was then reduced 50% and the above runs repeated with similar results excepting pull stick forces were reduced.

Boltrope tension position was then reduced to 0 and the above runs repeated with similar results. (It should be noted that even with 0 boltrope, pull stick forces were required with full nose down trim).

A complete run tabulation is attached.

**Records:** 26 channel oscillograph and external cine coverage.

**Observations:** It could be observed that the "cusp" of previous flight 11 was magnified by the boltrope tension. A full span cusp of approximately 1 1/2 foot width was apparent. This cusp did not change with boltrope tension position.

During short airborne periods the test bed appeared to be requiring greater stick and wheel deflections to maintain lateral and directional stability.

**Remarks:** It is believed that the stick force oscillations are a result of the fluttering of the trailing edge cusp. The boltrope tension caused the trailing edge to carry greater airloads thus moving the over-all aerodynamic center of pressure aft. This new c.p. produced the nose down moments which resulted in the pull stick forces.

The amplitude of the stick force oscillations was reduced by releasing boltrope tension but the frequency increased.

The fact that the boltrope effects were not completely eliminated by "zero" boltrope tension position indicates stretch in the wing material. In the unloaded condition the boltrope and trailing edge are identical. Any tension in the boltrope when the wing is loaded is due to wing stretch.

Preliminary check of strain gage data indicates no change in leading edge bending stresses as a result of boltrope tension.

It was decided to install battens in the wing trailing edge to reduce flutter and eliminate the unfavorable stick force oscillations associated with the boltrope.

Run	RPM	IAS	Trim	Boltrope	Remarks
1	1800	32	0	2 1/2	Stick force 100# pull
2	1900	34	6	2 1/2	
3	1900	35	8	2 1/2	
4	1900	35	10	2 1/2	
5	2000	37	10	2 1/2	
6	2000		12	2 1/2	Test bed very light
7	2100		12	2 1/2	
8	2100	37	0	1 1/4	Test bed airborne 20
9	2100	38	4	1 1/4	100# pull stick
10	2100	39	6	1 1/4	Pilot reports stick force
11	2100	36	7	1 1/4	pulse (Run 8 and 14)
12	2100		8	1 1/4	
13	2200	38	8	1 1/4	- and - stick forces
14	2200	39	8	1 1/4	required to maintain flt.
15	2200	47	10	1 1/4	Airborne 20 - 30 ft. IAS given is in descent.
16	2200	38	0	0	Stick oscillation aggravated.
17	2200		4	0	

Total test time 1.0 hrs.

FLIGHT TEST REPORT ARMY NO. 13

FLEX-WING MANNED FLIGHT VEHICLE N140N

**Objectives:** Test the ability of battens to reduce trailing edge flutter believed to be cause of stick force oscillations.

**Results:** Battens successfully eliminated stick force oscillations.

**Description:** The test was conducted at Brown Field, San Diego on September 28, 1961 at 7:38 A.M. Test was conducted under no wind conditions.

Seventeen runs were made varying trim position and engine RPM for three different boltrope "tension positions."

Runs 1 to 6 were made with boltrope tension position equal to 0.0. Runs 7-15 were conducted with boltrope position 1 inch. Runs 16 and 17 were conducted with minus 1 inch. A listing of all runs is attached along with sketch of batten installation. Runs were made in both directions on the runway and an altitude of approximately 50 feet was maintained during airborne portions.

**Data:** Records - 26 channel oscillograph data was taken in addition to external cine coverage of the complete test bed and gun camera coverage of the trailing edge underside.

Observations - Observers present generally agreed that the battens reduced trailing edge flutter and produced a standing wave just ahead of battens.

**Remarks:** The battens were effective in eliminating stick force oscillations cause by wing trailing edge flutter. It was decided to go on with the regular test program with the present configuration of battens and minus 1 inch boltrope position. Boltrope position minus 1 eliminates any tension in the trailing edge due to boltrope.

Test time - 53 minutes.

Run	RPM	IAS	Trim	Boltrope	Remarks
1	2000	38	0	0	Taxi run
2	2100	39	4	0	Taxi run
3	2200	40	6	0	Airborne at 39 m.p.h.
4	2200	40	6	0	Alt. 50 ft.
5	2200	40	6	0	(Trim 6 required for
6	2200	40	6	0	(this configuration
7	2200	42	0	1"	Taxi run
8	2200	43	4	1"	Airborne for short intervals
9	2200	42	6	1"	125# pull, sustained airborne
10	2200	42	8	1"	50# pull, 50 ft. alt.
11	2200	42	10	1"	
12	2200	42	12	1"	Trim 12 required
13	2650		12	1"	Full power T.O. and climb to 150'
14		45	13 3/4	1"	Low flys by camera man "hand off"
15			13 3/4		
16	2200	40	4 1/2	-1"	
17	2200	42	4	1	Trim 4 required

**FLIGHT TEST REPORT ARMY NO. 14**  
**FLEX-WING MANNED FLIGHT VEHICLE N140N**

**Objectives:** Qualitative longitudinal control check at 2000 ft. altitude.

**Results:** Stick force gradients acceptable for a range of speed 35 to 50 m. p. h.

**Description:** The test was conducted at Brown Field, San Diego on Sept. 29, 1961 at 8:51 A. M. A full power take-off and climb to 2000 ft. altitude was accomplished with an estimated rate of climb of 300 ft. per minute. The test bed was trimmed at airspeeds of 45, 40 and 35 m. p. h. and the limits of stick travel investigated at each speed. A steady sideslip to the left and right was accomplished at 40 m. p. h. and 2300 RPM. Descent from 2000 ft. was made at 45 m. p. h. IAS.

**Data:** 26 channel oscillograph data was recorded at each of the stabilized flight conditions.

**Remark:** Pilot reported considerable left rudder required to maintain heading and the condition was aggravated by reduced power in descent.

**Test time - 34 minutes.**

10/6/61

FLIGHT TEST REPORT ARMY NO. 15  
FLEX-WING MANNED FLIGHT VEHICLE - N140N

**Objectives:** Investigate longitudinal trim and stall approach characteristics. Obtain initial data for rate of descent study.

**Results:** Trim instability existed at speeds from approximately 42 to 50 knots. Right wing down tendency increased with increased velocity. Stall approaches were cancelled due to lateral instability problems.

**Description:** This test was conducted at Brown Field, San Diego on October 6, 1961. Take-off was scheduled for 0800 but a malfunctioning airspeed indicator delayed the flight for approximately 33 minutes. A fly-by at an altitude of from 5 to 10 feet was accomplished allowing ground personnel to visually check the aircraft for any Full AND trim was used. After lift-off, trim was reset for a 40 MPH climb.

Climb was terminated at an altitude of 2,000 feet. Starting with a trim setting of 6 1/2 at 46 MPH, airplane nose up trim was increased incrementally up to maximum ANU trim position. At each trim position, the speed was allowed to stabilize, and records were taken. The engine speed was held constant at 2400 RPM. Difficulty was experienced in trimming at the high speed end. The aircraft would not hold the trim speed.

In power off descent at 42 MPH, full left rudder was required to maintain wings level.

**Data:** Records

26 channel oscillograph data were taken for short intervals during the flight. Airborne camera coverage of wing buffet was also obtained.

Observations

Convoluting of left wing noted by ground observers during attempt to trim at  $V = 45$  MPH, and altitude = 2000 feet.

Pilot Comments

- a) Wing buffet "feed-back" to stick during climb.
- b) Unstable stick at 45 MPH Aircraft attempts to go to higher speed.
- c) With zero stick force at V = 50 MPH, aircraft rolls off to right.
- d) Good speed stability in 40 MPH trim range.
- e) Full left rudder required at 42 MPH, in power off descent.
- f) Lateral rocking during descent at 40 MPH with partial power.

**Remarks:**

It was decided that no further testing be attempted until lateral trim problem is resolved. Rigging check to be accomplished prior to next flight. Adjustable bolt rope to be installed and evaluated for lateral trim control on next flight. It was also decided that a roll attitude gyro be incorporated in the recorded data. A check of static engine thrust is to be accomplished as soon as practical.

**Flight Time:** 36 minutes

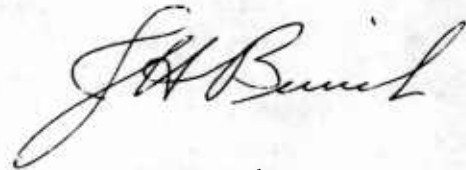

J. H. Burich

10/10/61

**FLIGHT TEST REPORT ARMY NO. 16**  
**FLEX-WING MANNED FLIGHT VEHICLE - N140N**

**Objectives:** To evaluate the effectiveness of a differential bolt-rope as a lateral trim device.

**Results:** Two low-altitude runs were attempted with zero bolt-rope tension. Excessive nose-down pitch was present. A hard landing was experienced on the second run. A broken keel was noted prior to the next run, and the test was halted.

**Description:** This test was conducted at Brown Field, San Diego on October 10, 1961. The initial phase of the day's test was begun at 0808 with zero bolt-rope tension and full AND trim. Over 200 pounds of full stick force was required with no lift-off.

The next run was started at 0814 with a trim setting of 6. As the speed increased, the trim setting was increased in steps to 10. Nose down pitch was reduced, but still required stick forces of approximately 100 pounds pull for lift-off. A hard landing, nose gear first, apparently caused the wing keel to buckle. The test was then halted.

**Data:** Records

26 channel oscillograph data were taken for both runs.

Observations:

The aircraft seems to fly with the platform in a more nose-down attitude than previously.

Pilot Comments

Pitch down characteristics indicate bolt rope may not be slack when wing is under load.

**Remarks:** It was generally agreed that the broken keel was caused by the hard landing rather than airloads.

The next test will be made with the bolt rope completely disconnected to eliminate possibility of bolt rope tension being introduced by wing inflation.

**Flight Time:** 2 minutes

**Engine Time:** 22 minutes

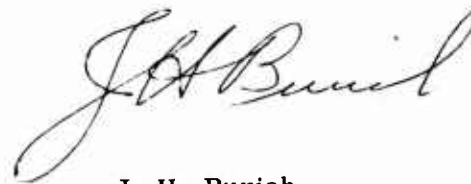
A handwritten signature in cursive script, appearing to read "J. H. Burich".

J. H. Burich

10/17/61

**FLIGHT TEST REPORT ARMY NO. 17**  
**FLEX WING MANNED FLIGHT VEHICLE - N140N**

**Objectives:** To determine whether flight characteristics were affected by keel repair. Longitudinal trim requirements were used as a basis of comparison.

**Results:** Longitudinal trim characteristics appear unchanged due to repair. Bolt-rope was completely detached from keel for this flight to preclude possible bolt-rope tension being introduced under flight loads.

**Description:** This test was conducted at Brown Field, San Diego on October 17, 1961. The initial phase of this day's test was commenced at 0803. Two short fly-by flights were made for both pilot evaluation of handling characteristics, and ground observation of wing contour. A roll in the trailing edge was noticed during the first fly-by, becoming less pronounced as the test progressed. Four fly-bys were accomplished before final take-off was made.

The take-off for the main portion of the test was made at 0828, with a trim setting of 9. The climb was made at approximately 38 M. P. H. to an altitude of 2,000 feet.

Difficulty was experienced again in attempting to trim at 45 M. P. H. at a trim setting of 6. The vehicle increased speed to 48 M. P. H. with the control column advancing to the full forward position. Left rudder and left wheel control was required for level flight.

With trim setting of 6 1/2, the vehicle attained steady state trimmed flight at approximately 40 M. P. H.

Another attempt to trim at 45 M. P. H. produced similar unstable characteristics as previously. Incremental trim changes up to a trim of 16, resulted in speed changes similar to those of previous flights.

The descent was accomplished with power off according to following schedule:

<u>Airspeed</u>	<u>Trim Setting</u>	<u>Rate of Descent</u>	<u>Comments</u>
37 M. P. H.	7 1/2	600 FPM	
37	7	700 FPM	Slight rudder req'd.
40	6	-	Little left rudder and wheel required

The landing was made with a trim setting of 8 1/2 at 0903.

**Data:**

Records

26 channel oscillograph data were taken intermittently throughout the flight.

Airborne motion pictures were taken during initial attempt to trim at 45 M. P. H.

Observations

Roll in wing trailing edge during initial phase of testing, becoming less pronounced as flight progressed.

Pilot Comments

- a) With trim setting of 6, no pull out (flare) capability to land.
- b) Low frequency wing dropping and wing motion feedback to controls during flight at 45 M. P. H.
- c) Trimmed at 39 M. P. H. (trim setting 8), a high frequency flutter was present in front of center batten.

**Remarks:**

No apparent changes in longitudinal characteristics were caused by keel repair. Initial roll in wing trailing edge could be caused by residual bolt-rope tension induced by bolt-rope friction. "Working" of the wing trailing edge under load would tend to relieve this condition.

**Flight Time:** 44 minutes

  
J. H. Burich

10/18/61

**FLIGHT TEST REPORT ARMY NO. 18**  
**FLEX-WING MANNED FLIGHT VEHICLE - N140N**

**Objectives:** To evaluate roll control and longitudinal dynamic stability.

**Results:** Control forces in turn without rudder are too high to be acceptable. Rough air caused cancellation of longitudinal dynamic stability tests.

**Description:** This test was conducted at Brown Field, San Diego, on October 18, 1961. Take-off was at 0819 hours at a trim setting of 9. During the climb at 39 M. P. H., left rudder was required. With zero wheel force, the control wheel remained deflected about 40° to the left. Further lateral control evaluation was cancelled pending installation of a platform roll attitude gyro.

Longitudinal trim requirements were checked for various trim settings for evaluation of repeatability.

The rate of descent was checked at the following speeds:

A/S	R/D
37 1/2 M. P. H.	580 F. P. M.
34 1/2 "	750 "
39 1/2 "	900 "

**Data:** Records

26 channel oscillograph records were taken intermittently.

Observations

None

Pilot Comments

In climb at 39 M. P. H., left rudder was required. With zero wheel force, the wheel assumed a position approximately 40° left. In descent, with power off, increased rudder is required with increased speed.

**Remarks:** Lateral stability and roll capability tests should be postponed until platform roll attitude gyro is installed and wings level flight can be maintained with zero wheel force.

**Flight Time:** 43 minutes

**Engine Time:** 56 minutes

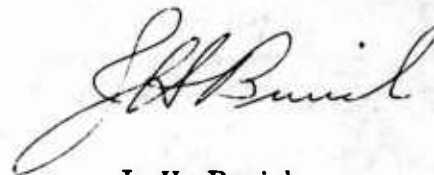

J. H. Burich

10/19/61

FLIGHT TEST REPORT ARMY NO. 19  
FLEX-WING MANNED FLIGHT VEHICLE - N140N

**Objectives:** To evaluate roll capabilities and characteristics.  
To check longitudinal phugoid.  
To determine minimum lift-off speed.

**Results:** This test was aborted during climb when pilot noticed abnormal roll in wing trailing edge. Some climb data was obtained.

**Description:** This test was conducted at Brown Field, San Diego, on October 19, 1961. Take off was at 0811 with a trim setting of 9. Climb was made at 40 M. P. H., at an average rate of climb of 280 feet per minute.

Approaching 2,000 feet, the pilot noticed an abnormal roll in the aft portion of the wing. During approach for landing, ground observers noticed bulge in wing starting just forward of the middle batten. The initial impression was that the battens were rotated and "digging in" to the fabric. Other comments referred to the condition as "ballooning".

Additional ground runs were made with and without the bolt-rope in an attempt to better define or eliminate this characteristic. No apparent change was observed.

**Data:** Records

Airborne moving pictures were obtained of the wing trailing edge.

Observations

Ground observers agreed that the wing condition noted was not apparent on previous flights. A spanwise depression from the keel to the leading edge of the center batten was noticed even during low speed taxi runs, becoming more apparent as lift-off speed was approached.

Pilot Comments

From the cockpit, the wing contour appeared abnormal. "It looks as if someone were lying on top of the wing".

**Remarks:** A possible cause of the wing depression is the absence of any bolt-rope action, allowing the batten to rotate and "dig-into" the wing. A series of fly-bys with varying amounts of bolt-rope tension is planned.

**Flight Time:** 33 minutes

**Engine Time:** 56 minutes

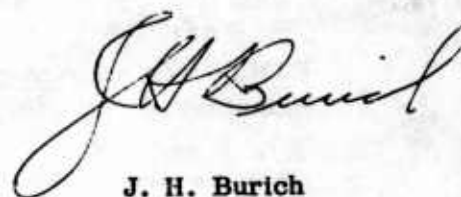

J. H. Burich

10/20/61

**FLIGHT TEST REPORT ARMY NO. 20**  
**FLEX-WING MANNED FLIGHT VEHICLE - N140N**

**Objectives:** To determine effect of bolt-rope tension on wing contour abnormality noted on preceding flight.

**Results:** Four bolt-rope settings were tested. The maximum variation was approximately 3/4 inches. A slight change in the contour could be detected. No noticeable change in stick force was noted. Higher bolt-rope tension settings were planned, but the test had to be discontinued due to wind at 0900.

**Description:** This test was conducted at Brown Field, San Diego, on October 20, 1961. The test consisted of seventeen low-level fly-bys. The first take-off was at 0810. Bolt-rope changes were made in increments of 1/4 inches up to a maximum variation of 3/4 inches. Several fly-bys were accomplished with each bolt rope setting.

No appreciable improvement was noted at any of the settings, up to the maximum tested.

**Data:** Records

26 channel oscillograph data were taken on two runs only.

Airborne camera coverage was also obtained on several of the runs.

Observations

In general, no appreciable improvement was noted, although at the maximum setting, the abruptness of the depression appeared diminished, accompanied by an increase in trailing edge "ballooning".

Pilot Comments

No noticeable change in force characteristics with change in bolt rope tension. Fifteen to twenty pounds of pull required with 3/4 inch bolt-rope setting and trim at 8.

**Remarks:** Continue testing with higher bolt rope settings. Study motion pictures of wing with scalloping or other re-design in mind.

**Flight Time:** 17 minutes

**Engine Time:** 50 minutes.

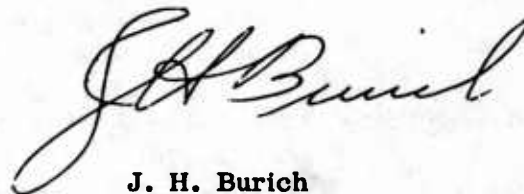

J. H. Burich

10/24/61

**FLIGHT TEST REPORT ARMY NO. 21**  
**FLEX-WING MANNED FLIGHT VEHICLE - N140N**

**Objectives:** Continued investigation of effect of bolt-rope tension on wing contour.

**Results:** Several bolt-rope settings ranging from initial + 1/2" to initial + 1 7/8" were tested with increasing bolt-rope tension, the abnormal depression forward of the batten area became less abrupt, but a billowing forward of the depression became more pronounced. Pitching moments were as anticipated.

**Description:** This test was conducted at Brown Field, San Diego, on October 24, 1961. Three fly-bys were performed with each of the following bolt-rope settings:

Initial setting + 1/2, 1, 3/4, 1 1/4, 1 7/8 and 7/8 inches.

**Data:** Records

Ground-borne motion picture coverage of all runs.  
26 channel oscillograph data were taken intermittently.

Observations

With increasing bolt-rope tension, the wing contour characteristics appeared to change. With the lower bolt-rope settings, the discontinuity in the wing contour was very abrupt and located immediately forward of the batten area. As bolt-rope tension was increased, the depression appeared to be less abrupt. However, a billowing forward of the depression, becoming more pronounced with increasing bolt-rope tension, was noted.

Pilot Comments

The stick forces and longitudinal trim requirements appeared to be as expected with increasing bolt-rope tension.

A low frequency buffet feed-back to the control column was felt on one of the runs.

**Remarks:**

Although increased bolt-rope tension seems to decrease the abruptness of the contour discontinuity, an acceptable configuration does not appear attainable. The wing fabric tends to pull forward from the trailing edge. The presence of the battens apparently allows the entire trailing edge to act as a solid section.

It was decided that chordwise tension in the fabric is required and that scalloping plus bolt-rope tension may be a solution.

Tests with battens removed will be performed to determine area to be scalloped.

**Flight Time:** 10 minutes

**Engine Time:** 55 minutes

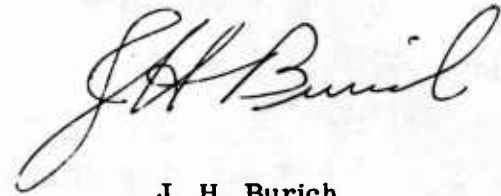

J. H. Burich

10/25/61

**FLIGHT TEST REPORT ARMY NO. 22**  
**FLEX-WING MANNED FLIGHT VEHICLE - N140N**

**Objectives:** To determine wing contour characteristics with varying bolt-rope tensions, and battens removed.

**Results:** With battens removed, the tendency of trailing edge to move forward is still apparent, with no appreciable change due to varying bolt-rope tension. Excessive trailing edge flutter was present and feed-back to control column objectionable. Two runs with inboard battens only were also made with a slight reduction of flutter.

**Description:** This test was conducted at Brown Field, San Diego, on October 24, 1961. Five fly-bys were accomplished with the battens removed and bolt-rope settings of initial + 7/8" and initial + 1 3/8". Trailing edge flutter was very pronounced with no apparent change due to bolt-rope. The inboard battens were installed for the last two runs in an attempt to reduce flutter. No appreciable change was noted.

**Data:** Records

Ground-borne motion picture coverage of all runs.

Observations

Trailing edge flutter was slightly reduced by addition of inboard battens.  
Wing contour discontinuity appears to be less pronounced than with battens installed, but in the same area.

Pilot Comments

Flutter feed-back to control column is objectionable.

**Remarks:** The contour abnormality occurs in the same general area with or without battens, i. e., inboard section of wing just forward of the batten area. Scalping should be designed for maximum effect in this area.

**Flight Time:** 7 minutes

**Engine Time:** 30 minutes

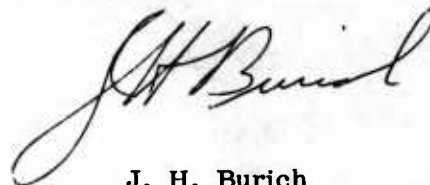

J. H. Burich

10/30/61

**FLIGHT TEST REPORT ARMY NO. 23**  
**FLEX-WING MANNED FLIGHT VEHICLE - N140N**

**Objectives:** To study effects of scalloping on wing contour and flight characteristics.  
To establish desirable bolt-rope tension for acceptable flight characteristics.

**Results:** Scalloping of wing appears to improve wing contour but gives rise to pitch-up tendency. Increasing bolt-rope tension produces desired pitch-down. With maximum slack in bolt-rope, and full airplane nose down trim, a slight push force was required at 38 M. P. H. Maximum bolt-rope setting was 2 1/4 inches from initial setting. With this setting, and a trim setting of 4, a pull force was required for flight at 40 M. P. H. Test was not completed due to increasing cross-wind.

**Description:** This test was conducted at Brown Field, San Diego, on October 30, 1961. Nine fly-bys were accomplished with the battens removed, and various bolt-rope settings. Full airplane nose down trim was used throughout. With minimum bolt-rope, a push force was required at 38 M. P. H. At the highest bolt-rope setting tested, (2 1/4" from initial) a pull force was required at 45 M. P. H. A high frequency trailing edge flutter was present, and was being fed back into the control column.

The battens were installed, and the bolt-rope setting remained fixed at 2 1/4". Ten fly-bys were accomplished with trim settings varying from full AND to 6. At the trim setting of 6, a push force was required at 42 M. P. H.

Due to cross-wind, testing of higher bolt-rope settings was cancelled.

**Data:** Records

Ground-borne motion picture coverage of all runs. 26 channel oscillograph data were taken intermittently.

Observations

The wing contour appears greatly improved due to scalloping. Trailing edge flutter was present during runs with battens removed.

Pilot Comments

Change of force characteristics with change in bolt-rope setting was very apparent. Suspect higher degree of instability than with unscalloped wing.

Remarks: Testing at higher bolt-rope settings is necessary in attempt to duplicate trim requirements of unscalloped wing.

Flight Time: 19 minutes

Engine Time 1 hour and 4 minutes

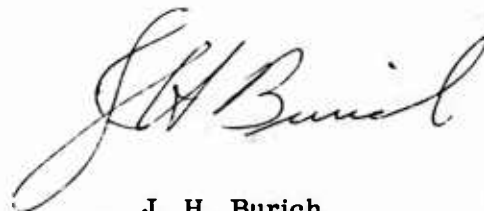
A handwritten signature in cursive script, appearing to read "J. H. Burich".

J. H. Burich

11/2/61

FLIGHT TEST REPORT ARMY NO. 24  
FLEX-WING MANNED FLIGHT VEHICLE - N140N

- Objectives:** To establish bolt-rope tension requirements for scalloped wing. Continuation of Flight No. 23.
- Results:** A bolt-rope setting of initial + 1 3/4" appeared to give the desired trim speed at a trim setting of 8. Runs at other trim settings were cancelled due to wind.
- Description:** This test was conducted at Brown Field, San Diego, on November 2, 1961. Four fly-bys were made at a bolt-rope setting of initial + 2 1/4" at trim settings varying from 5 to 8. At a speed of 40 M. P. H. a pull force was required at all trim settings.

The bolt-rope tension was reduced to initial + 1 3/4". Two fly-bys were performed with this bolt-rope setting at a trim setting of 8. Zero stick force was required at approximately 39 M. P. H. Testing at additional trim settings was cancelled due to wind.

**Data:** Records

26 channel oscillograph data was taken intermittently.

Ground-borne moving picture coverage was available for the last four runs only.

Airborne moving pictures of right wing trailing edge were taken on the last two runs.

Observations

The wing contour appeared smooth except for a slight spanwise depression just forward of the center batten. The test bed appeared to be level during both lift-off and landing.

Pilot Comments

The aircraft "feels good".

**Remarks:** Additional testing with present bolt-rope setting at other trim settings is required to compare stability of scalloped and unscalloped wings.

**Flight Time:** 6 minutes

**Engine Time:** 22 minutes.

A handwritten signature in cursive script, appearing to read "J. H. Burich".

J. H. Burich

11/3/61

**FLIGHT TEST REPORT ARMY NO. 25**  
**FLEX-WING MANNED FLIGHT VEHICLE - N140N**

**Objectives:** To evaluate longitudinal trim requirements in free air.

**Results:** Marginal stability existed in speed range from 33 to 45 M. P. H. Pilot experienced difficulty in establishing and holding trim speed.

Depression in aft portion of wing appeared more pronounced than on previous flights with scalloped wing.

**Description:** This test was conducted at Brown Field, San Diego, on November 3, 1961. Five fly-bys were accomplished at various trim settings for pilot qualitative analysis of handling characteristics.

Take-off was at 0802 at a trim setting of 7 and full power. Full power was maintained throughout climb to 2000 feet.

Attempts were made to hold a given trim speed at various trim settings from 6 1/2 to 8. Aircraft had a tendency to drift off speed at all trim settings. A change in stick position accompanied the drift in airspeed. A stable condition appeared to exist with the stick in either the full aft or full forward position.

With trim set at 7 1/2 and airspeed at approximately 38 M. P. H., full forward and full aft stick were applied. Even though the airspeed changed as expected, essentially zero stick force was required.

An attempt to trim during descent resulted in similar speed instability.

Landing was made at 0842.

**Data:****Records**

26 channel oscillograph data was taken intermittently. Ground-borne moving picture coverage was available during fly-bys. Airborne moving pictures of right wing trailing edge were also taken intermittently.

**Observations**

A spanwise depression in the wing just forward of the batten area was apparent. This depression was more pronounced than on the previous flights with the scalloped wing, but not as pronounced as on the unscalloped wing.

**Pilot Comments**

The lack of stability is very apparent. Stick force required to change speed practically non-existent.

**Remarks:**

It appears that scalloping has resulted in forward shift of the aerodynamic center with a resulting decrease in longitudinal stability. Introduction of artificial stability through variable bolt-rope should be investigated, time permitting. The appearance of the depression in the wing may be the result of permanent set in the fabric or the effect of humidity and/or temperature on the fabric characteristics.

**Flight Time:** 46 minutes

**Engine Time:** 1 hour 10 minutes

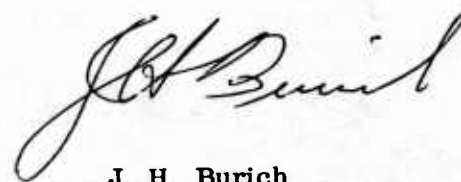

J. H. Burich

11/8/61

FLIGHT TEST REPORT ARMY NO. 26  
FLEX-WING MANNED FLIGHT VEHICLE - N140N

**Objectives:** To determine static longitudinal stick-fixed stability characteristics.  
To evaluate constant heading sideslip characteristics.

**Results:** With the stick fixed in approximately neutral position, a trim variation from 4 to 9 resulted in a speed change of approximately 4 MPH. Testing to higher trim settings was cancelled due to turbulence.

Maximum attainable sideslip appears to be governed by available roll control.

**Description:** This test was conducted at Brown Field, San Diego, on November 8, 1961. Take off was at 0805 hours with full power, and a trim setting of 7. Climb to 2000 ft. was accomplished at 38 MPH.

At 2000 ft., a trim speed of 40 MPH was attained with a trim setting of 6 resulting in a stick position of neutral. With the stick fixed in this position, the trim setting was decreased to 4 and then increased to 9. The accompanying speed change was from 41 to 37 MPH. Testing at additional trim settings was cancelled due to turbulence.

Steady state sideslip data at 40 MPH was obtained with approximately one-half rudder deflection. Maximum roll control was required in sideslips with less than full rudder.

**Data:** Records

26 channel oscillograph data was taken intermittently.

Observations

No comments from ground observers.

**Pilot Comments**

**Aircraft feels fairly stable with stick locked.**

**Remarks:** Value of static stick-fixed tests appear questionable. Dynamic stick-fixed tests should be more meaningful.

**Flight Time:** 36 minutes

**Engine Time:** 50 minutes



**J. H. Burich**

## FLEX-WING MANNED FLIGHT VEHICLE - N140N

- Objectives:** To continue static stick-fixed tests.  
To evaluate dynamic stick-fixed stability.
- Results:** With the stick fixed in approximately neutral position, the trim setting was varied from 3 to 15. The speed variation was from 52 to 37 M. P. H. Rough air caused cancellation of dynamic tests.
- Description:** This test was conducted at Brown Field, San Diego, on November 9, 1961. Take-off was at 0748 hours, with power set at 2500 RPM and trim at 6 1/2. A full throttle climb was performed at 40 M. P. H. to 2500 feet.

A check of static longitudinal stick-free stability was conducted at a trim speed of 40 M. P. H. A speed of 45 M. P. H. was attained with the stick full forward and approximately 33 MPH with the stick full aft.

With a trim setting of 6 1/2 at 40 MPH, the control stick was approximately in the neutral position. The stick was locked in this position, and the trim varied from 3 to 15. The speed variation was from 52 M. P. H. to 37 M. P. H.

Descent was performed at various airspeeds, and rate of descent noted.

**Data**Records

26 channel oscillograph data were recorded intermittently.

Observations

No comments from ground observers.

Pilot Comments

At 52 M. P. H. full left rudder is required to prevent roll-off to right. Trim indicator showed maximum trim setting of slightly over 15. A definite change in fuselage angle is apparent with stick fixed.

Remarks: Discrepancy in trim indicator may be caused by decreased voltage in instrumentation circuit. Dynamic stick-fixed stability should be checked on next flight.

Use of asymmetric bolt-rope as a means of correcting right roll should be evaluated when practical.

Flight Time: 45 minutes

Engine Time: 59 minutes



J. H. Burich

11/10/61

FLIGHT TEST REPORT - ARMY NO. 28

FLEX-WING MANNED FLIGHT VEHICLE - N140N

**Objectives:** To investigate the effect of asymmetric bolt-rope on lateral trim.

**Results:** An asymmetry of one inch in bolt-rope settings appeared to correct the right roll tendency.

**Description:** This test was conducted at Brown Field, San Diego, on November 10, 1961. Due to low ceilings, the planned test was cancelled. It was decided to conduct an evaluation of asymmetric bolt-rope for roll control instead.

Two fly-bys were conducted with symmetrical bolt-rope settings. Full left rudder was required at 49 M. P. H.

An asymmetry of one inch in bolt-rope settings was accomplished by increasing the right wing bolt-rope tension by 1/2 inch and decreasing the left wing by 1/2 inch. Two fly-bys were conducted at this setting with no rudder required at highest speed attained (53 M. P. H. ). However, a pull force was required with a trim setting of  $7 \frac{1}{2}$  at this speed, indicating a net increase in pitch down moment from the asymmetric change in bolt-rope settings.

Both bolt-ropes were slackened 1/2 inch and two fly-bys were accomplished in this configuration. No rudder was required, on either of these runs. However, a slight push force was required at 45 M. P. H. with a trim setting of  $4 \frac{1}{2}$ , indicating the need for additional pitch down moment from the bolt-rope.

Both bolt-rope tensions were increased by 1/4 inch. A fly-by in this configuration was aborted due to cross-wind. Test was discontinued for the day.

**Data:** Records

26 channel oscillograph data were recorded on every fly-by.

Observations

No comments from ground observers.

Pilot Comments

One inch asymmetry in bolt-rope tensions eliminates all right wing down roll tendencies, even at higher speeds.

**Remarks:** Asymmetric bolt-rope appears to be the fix for roll-off problem. Next flight will be to check this fix out of ground effect, and through wider speed range.

**Flight Time:** 7 minutes

**Engine Time:** 50 minutes

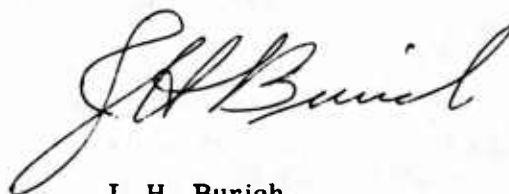

J. H. Burich

11/14/61

**FLIGHT TEST REPORT ARMY NO. 29**

**FLEX-WING MANNED FLIGHT VEHICLE - N140N**

- Objectives:** To establish asymmetric bolt-rope setting for both lateral and longitudinal trim  
To investigate dynamic longitudinal stick-fixed stability  
To investigate dynamic lateral/directional controls fixed stability.
- Results:** An asymmetric bolt-rope setting was established during eight fly-bys which produced the desired lateral and longitudinal trim characteristics.  
Stick fixed dynamic longitudinal stability indicated heavy damping at a trim speed of 40 M. P. H.  
Controls - fixed lateral/directional stability; also convergent although not as heavily damped as longitudinally.
- Description:** This test was conducted at Brown Field, San Diego, on November 14, 1961. The initial portion of the test period was devoted to the establishment of an optimum bolt-rope setting. Eight fly-bys at altitudes of approximately 10 to 20 feet were accomplished with various bolt-rope settings. Initially, a push force was required to hold level flight at 40 M. P. H. and a trim setting of 6. An additional 1/2" of bolt-rope tension was introduced into both wings. This adjustment resulted in the desired trim characteristics.
- Take-off for the second phase of the test plan was at 0840 hours. Full power was used throughout the climb.
- At an altitude of 2,000 ft. a trim speed of 40 M. P. H. was established. The "elevator" control was pulsed and then locked in the trim position. Two pulses aft and two forward were performed with heavy damping present in all.
- Rudder "kicks" for lateral/directional stability evaluation were also accomplished at this same flight condition. Controls were locked after initial disturbance, and damping was good.

During power off descent, the airspeed was increased to 52 M. P. H. to check roll characteristics. A slight amount of left rudder was required.

**Data:**

Records

26 channel oscillograph data were recorded intermittently.

Observations

No comments from ground observers.

Pilot Comments

Rudder requirements for roll-off correction reduced to the point of being negligible  
Longitudinal damping is very heavy  
Lateral/directional oscillations are also convergent, although not as heavily damped as longitudinal.

**Remarks:** Retain asymmetric bolt-rope for roll-off correction. Investigate lateral/direction stick-free stability as soon as practicable.

**Flight Time:** 37 minutes

**Engine Time:** 1 hour and 47 minutes

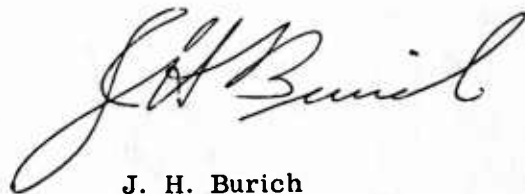

J. H. Burich

11/15/61

FLIGHT TEST REPORT ARMY NO. 30  
FLEX-WING MANNED FLIGHT VEHICLE - N140N

**Objectives:** To investigate spiral stability characteristics. To evaluate lateral/directional dynamic stability (controls free).

**Results:** When placed in a right bank, the vehicle maintains the bank angle, exhibiting no tendency to either increase or decrease bank angle. In banks to the left, the tendency is for the angle to increase. Lateral/directional oscillations resulting from control pulses exhibit good damping.

**Description:** This test was conducted at Brown Field, San Diego, on November 15, 1961. Take-off was at 0758 hours with a trim setting of 6 at full power. The climb to 2000 ft. was accomplished at 40 M. P. H. A slight amount of left rudder was still required.

At a trim speed of 40 M. P. H., the vehicle was placed in shallow banks to both the left and right, and the controls returned to neutral. The vehicle maintained the established bank angle to the right, but tended to increase the bank to the left.

Maintaining this same trim speed, rudder "kicks" were accomplished to produce lateral/directional oscillations. The controls were unrestricted, and damping was good.

**Data:** Records

26 channel oscillograph data were recorded intermittently.

Observations

No comments from ground observers.

Pilot Comments

During rudder "kicks" rudder had to be returned to neutral indicating very low rudder restoring moments.

**Remarks:** No further flight testing anticipated.

**Flight Time:** 52 minutes

**Engine Time:** 1 hour and 11 minutes

A handwritten signature in cursive script, appearing to read "J. H. Burich".

J. H. Burich

### 13.2 List of Drawings (Original Configuration).

Dwg. No.	Title
A04-1000	Final Assembly - Model 140
A04-1001	Platform Assembly
A04-1005	Landing Gear Truss
A04-1006	Fuselage Truss
A04-1008	Engine Mount Truss
A04-1009	Wing Support Tripod
A04-1021	Engine Cooling Fan
A04-1022	Layout - Engine Installation
A04-1023	Keel Assembly - Wing
A04-1024	Leading Edge Assembly - Wing
A04-1025	Truss - Wing
A04-1027	Fitting - Leading Edge Forward
A04-1031	Fitting - Keel Apex
A04-1032	Fitting - Keel Actuator
A04-1033	Spacer - Keel Assembly Bolt
A04-1035	Retainer - Bearing, Wing Keel
A04-1039	Yoke - Aft Landing Gear
A04-1043	Steering Arm
A04-1044	Throttle Control Assembly
A04-1046	Crank Assembly - Steering Linkage
A04-1047	Axle - Control Column
A04-1048	Pulley Bracket - Steering Linkage
A04-1049	Bearing Retainer - Control Column
A04-1050	Tie Rod - Steering Linkage
A04-1051	Control Column
A04-1052	Pulley - Control Column
A04-1053	Support - Control Column
A04-1054	Shaft - Control Wheel
A04-1055	Spacer - Control Wheel
A04-1056	Seat Assembly
A04-1057	Link - Pitch Control Lower Vee
A04-1058	Housing - Shaft, Control Wheel
A04-1059	Link - Pitch Control
A04-1060	Exhaust and Carb. Heat System
A04-1061	Link - Pitch Control Upper Vee
A04-1062	Crank Assembly
A04-1063	Bar - Equalizer

Dwg. No.	Title
A04-1064	Cable - Control
A04-1065	Bushing - Wheel, Control
A04-1066	Fairlead - Cable, Control
A04-1067	Beam-Wing Support
A04-1068	Torque Tube - Wing Support
A04-1069	Link - Roll Control
A04-1070	Fitting - Seat Attach
A04-1071	Tank - Fuel
A04-1072	Cable Assembly, Steering Linkage
A04-1074	Spacer - Wing Support
A04-1075	Arm - Roll Control
A04-1076	Link - Wing Support
A04-1077	Inst. Panel Installation & Assembly
A04-1078	Installation - Tank, Fuel
A04-1079	Cable - Pitch Stop Aft
A04-1080	Cable - Pitch Stop Fwd.
A04-1081	Bracket - Pitch Stop
A04-1082	Cable-Roll Stop
A04-1083	Brake Pedal & Hyd. Syst. Install.
A04-1084	Valve Install. - Fuel Shut-Off
A04-1085	Bracket Install. - Roll Control
A04-1087	Layout - Wing Membrane
A04-1088	Nose Fairing Installation
A04-1089	Pitot Tube & Radio Power Unit Install.
A04-1090	Trim Actuator Installation
A04-1091	Antenna Installation
A04-1092	Washer-Control Wheel
A04-1093	Fuel Syst. Equipt. Installation
A04-1097	Layout - Rudder Installation
A04-1098	Engine Mount Truss (Lycoming - 0-360)
A04-1099	Layout - Revised Wing Membrane

### 13.3 List of Sketches Showing Modifications

Sketch No.	Title
1	Repairs to Control System
2	Rework - Platform
3	Side Brace - Control Column Bearing
4	Strap - Canopy Anti-Sag
5	Repair - Keel
6	Keel Reinforcement
7	Keel Sway Brace
8	Auxiliary Wing Pivot - Forward
9	Auxiliary Wing Pivot - Aft
10	Bushing - Keel Pivot
11	Relocation of Actuator Fitting
12	Reinf. at Aft Landing Gear
13	Reinf. at Forward Landing Gear
14	Link Pitch Control Revised
15	Yoke-Pitch Control Revised
16	Brace - Pitch Control "V"
17	Gusset - "V" Brace
18	Pivot - Pitch and Roll Control
19	Clearance Notch - Control Yoke
20	Cable Anchorage - Wing Truss
21	Fitting - Cable Anchor
22	Strut - Anchor Fitting Brace
23	Pulley Bkt. - No. 14 Link Upper
24	Pulley Bkt. - Fus. 71 W. L.
25	Pulley Bkt. - Fus. Sta. 107.28
26	Pulley Bkt. - No. 14 Link Lower
27	Adapter - Oil Cooler Lines
28	Strap - Rudder Pedal Arm
29	Bell Crank - Roll Control
30	Pulley Bkt. - Fus. Sta. 70.5
31	Pulley Support - Fus. Sta. 70.5
32	Spacer - Propeller
33	Socket - Rudder Upper Hinge
34	Horn - Rudder Control
35	Rudder Assembly
36	Hinge - Rudder

Sketch No.	Title
37	V - Brace - Rudder Support
38	Detail - Apex Fitting - V Brace, Rudder Support
39	Tripod - Rudder Support
40	Pulley - Bkt. - Rudder "V" Brace
41	Pulley Bkt. - Rudder Fwd. Lower
42	Pulley Bkt. - Rudder Fwd. Upper
43	Stack - Exhaust Ejector
44	Spacer - Exhaust System (Lycoming 0-360 Eng.)
45	Cone - Exh. Sys. Flanged (Lycoming 0-360 Eng.)
46	Spacer - Propeller (Lycoming 0-360 Eng.)
47	Ftg. Assy. - Eng. Mt. Lower Attach
48	Adapter - Air Filter to Carb.
49	Cable Anchorage Revised - Wing Truss
50	Fitting - Cable Anchorage (Revised)
51	Trailing Edge Cable
52	Keel Reinforcement

#### **13.4 Summary of Contractor Sponsored Test Program**

Prior to the commencement of the test program covered by the main body of this report, a safety, flight and functional test program had been conducted by the Ryan Aeronautical Company.

The history, results and recommendations of these tests were summarized and submitted in the form of a Program Status Report, which is presented in its entirety in this section.

**PROGRAM STATUS REPORT  
ON THE  
RYAN AERONAUTICAL COMPANY  
FLEXIBLE WING TEST VEHICLE**

13-50

## TABLE OF CONTENTS

### Section

- 1.0 Summary
  - 1.1 Recital
  - 1.2 Objectives Accomplished
  - 1.3 Demonstrated Capabilities
  - 1.4 Data Obtained
- 2.0 Introduction
  - 2.1 Purpose
- 3.0 Discussion
  - 3.1 General
  - 3.2 Qualitative Resume of Flight Tests Conducted
  - 3.3 Structural Integrity Results
  - 3.4 Configuration Changes
  - 3.5 Problem Areas
  - 3.6 Conclusions and Recommendations

## 1.0 SUMMARY

### 1.1 Recital

The Ryan Aeronautical Company's interest, studies and application engineering of the "Rogallo Wing" or "Paraglider" resulted in a firm conviction that this concept has a wide range of applicability. To support utilization and provide much needed additional data, Ryan Aeronautical Company decided to design, fabricate and test a "Flex Wing" test vehicle to provide data and demonstrate feasibility and applicability of the wing. A powered, manned, full-scale low wing loading configuration was selected to permit greatest flexibility of test and facilitate rapid acquisition of qualitative as well as quantitative results.

### 1.2 Objectives Accomplished

The Test bed was designed and fabricated incorporating a two control system of CG movement to provide longitudinal and lateral flight control. It appeared that due to high values of  $C_{N_B}$  and  $C_{L_B}$  directional control by other means could be obviated as a requirement of the test configuration.

The safety of flight and functional flight program was successfully performed through a series of ground and taxi tests, lift-offs and pattern flights.

The tests conducted corroborate the original assumptions on wing applicability and flight control by CG shift only.

### 1.3 Demonstrated Capabilities

The success of the test program has demonstrated that the theoretical and wind tunnel data, provided largely by NASA, is basically correct. The tests have verified the later lift and drag data provided by NASA wind tunnel studies. Flights at lift coefficients of up to 1.15 have been realized. Sustained, controlled flight has been accomplished successfully by means of CG shift.

It has been demonstrated that a flexible wing test vehicle grossing out at 1,500 pounds with a wing loading of 2.7 pounds per square inch can be safely controlled by pilot effort alone.

#### 1.4 Data Obtained

The primary quantitative data gained from the flight program has borne out the fact that the aerodynamic assumptions made regarding load distributions between the main supporting structures of the wing are essentially correct.

Qualitative data obtained indicates that longitudinal control is adequate with approximately one third of the control range initially provided in the test bed. Early tests produced results which required relocating the wing to bring the center of pressure closer to the control pivot point. During the midportion of the program, ballast attached to the rear of the wing keel was removed, thereby producing a horizontal shift in CG of three (3) inches. Subsequent flights indicated that CG position is not extremely critical if adequate provisions for pitch trim and control are provided.

## 2.0 INTRODUCTION

### 2.1 Purpose

The purpose of this report is to present the results thus far gained from Ryan Aeronautical Company's flight safety and functional flight test program. It is believed that the program has been successfully completed and the test bed should be prepared for initiation of the flight tests as outlined in the United States Army sponsored flight test contract.

## 3.0 DISCUSSION

### 3.1 General

During the period of testing which originated in mid-March, 1961, the test bed has undergone 111 taxi runs in addition to other ground tests to evaluate engine performance and heating problems. Sixty-one (61) lift-offs and flights were effected during the taxi tests mentioned. Six (6) of these flights were performed away from the runway in patterns confined to an area within the confines of the airfield. Total test time, which does not include ground tests, is 8 hours, 46 minutes.

### 3.2 Qualitative Résumé of Flight Tests Conducted

A brief description of the sequential test program and the prominent results is presented below:

Tests 1 through 6 - 44 taxi runs were completed during this series of tests up to speeds of 42 knots.

During the early portion of these tests, a failure made it evident that for ground handling the wing keel design should allow for larger down bending loads than had previously been considered necessary.

The longitudinal control forces existing during the higher speeds revealed that the wing resultant force vector was not in proper relation to the longitudinal control pivot point. However, results also indicated that the method and range of longitudinal trim control was entirely satisfactory. The range of CG control provided through longitudinal control column movement was found to be approximately three times that necessary for satisfactory control during flight.

Landings after these early lift-offs resulted in yielding of the structure at the point of landing gear truss attachment, thus requiring local reinforcement.

During these tests, static propeller thrust was determined at a series of steady state engine RPMs. The recorded data showed that available thrust was approximately 5 percent higher than calculated.

Test 7 through 11 - During this series of tests, 12 flights were made and 5 taxi runs in 10-15 knot, 90° cross winds. The most significant results of these tests proved that lateral control through CG movement was feasible, although cross wind operation requires a specific technique. Static ground tests included in this series indicated a loss of 75 percent of CG movement relative to control wheel deflection under simulated flight loads. The loss in CG movement was attributed to excessive structural deflection.

Lateral control forces appeared to be undesirably high. The excessive structural deflection combined with objectionable forces indicated a need for changes of the lateral control system.

The taxi tests accomplished in the moderate 90° cross winds bore out early findings that lowering the leading edge into the wind during ground operation would not only reduce negative weather cocking tendencies but would also reduce required control forces produced by the high  $C_{L_B}$  existing with high effective angles of attack.

Test 12 through 19 - During these tests 50 flights were effected. Ballast weights which had been placed at the rear of the wing keel for static balance were removed prior to the latter flights. Removing the weights did not adversely effect the longitudinal control forces as longitudinal trim capability was well within the latitude of compensation. The CG shift resulting from removal of the ballast was three inches forward and one inch downward. The moment of inertia of the wing was reduced by approximately 50 percent with ballast removal, thereby considerably reducing longitudinal control acceleration forces.

The required propulsive power in the test bed had been determined on the basis of early NASA lift-drag data. The apparent lack of sufficient power to realize climb capability initially calculated substantially agrees with the later NASA drag data. Rate of climb tests run during this series of flights, when plotted against calculated data, indicates that the later NASA data is accurate. These plots are presented as an enclosure to this report.

Speed-power relationships indicate ground effect has a definite influence on the behavior of this type of flight vehicle. No data has been made available on the nature and magnitude of ground effect as applied to the flexible wing concept and these tests have shown qualitatively that a definite reduction in power required exists in ground effect. The effect is apparent within approximately one wing span of altitude above ground surface. Subsequent flight tests will

yield quantitative data in this area.

Reduced power landing approaches were briefly evaluated with indications that optimum approach speeds, power off, may be above 40 knots for a vehicle similar to the test bed in weight and wing loading.

### 3.3 Structural Integrity

The design of the vehicle was started with a very limited amount of aerodynamic data; therefore, certain aerodynamic assumptions of the distribution of load between the main elements of the flex wing had to be made.

In the present configuration of the test vehicle, the two spreader bars are designed as a leading edge supporting truss. This was necessitated by the way in which the lateral control was intended to function.

The structural information sought relevant to the wing design was:

1. Magnitude of loads at the high stress points along the keel.
2. Magnitude of loads at the high stress points along the leading edges.
3. Spreader bar loads.
4. Leading edge to keel transfer loads at the apex.

A number of strain gauges were used to cover other areas of interest such as control forces, pitch and roll wing attitudes with reference to the fuselage, air velocity, engine RPM, yaw attitude, etc.. The remaining oscillograph channels were used to instrument the primary wing structure and its supporting truss.

The strain gauges were mounted at crucial locations:

1. Shear - ahead of the front keel support.
2. Shear - behind the aft keel support.
3. Leading Edge Bending Moment (LEBM) at Leading Edge Station 188 - aft of the L. E. support in plane of the wing fabric.

4. At the same location but bending moment out of the plane of wing fabric.
5. LEBM at the center of Beam-Column portion of the L. E. in the plane of wing fabric.
6. At the same location but bending moment out of the plane of wing fabric.
7. L. E. compression load at the apex.
8. Tension in the wing truss lower member.
9. Compression in the wing truss upper member.
10. L. E. to keel vertical transfer load (at the apex).
11. L. E. to keel lateral transfer load (at the apex).

From the recordings of the above strain gauges, it was possible to evaluate approximately the total lift by adding Items 1 and 2 and multiplying the sum by a correction factor accounting for a load on a portion of the wing between the shear gauges.

Dividing the above lift by the flight weight of the vehicle, an approximate load factor was obtained.

In preliminary investigation, these instantaneous load factors were used to correlate the calculated values of applied loads to those which occurred in flight.

Numerical Findings from Tests Flown 7-15 May

Max. Load Factor - 1.35

Ratio of LEBM at Station 188  $\frac{\text{test}}{\text{calculated}}$  = .94 at the above load factor.

This is a ratio of corrected values computed in the following manner:

$$\text{Bending Moment Ratio} = \frac{\frac{\text{(BM flight)}}{\text{(n flight)}}}{\text{BM calc} \frac{\text{(W flight)}}{\text{(W calcul.)}}}$$

From the test, it is evident that the increasing load factor "n", caused by gust or control actuation or both, is accompanied by a forward shift of the air load, thus tending to reduce the bending moment at L. E. Station 188. The lowest B. M. ratio of .83 occurred at about n = 1.3.

Although the trend is clear, the scatter of the points on a graph of "n" versus B. M. ratio is somewhat high since no close correlation with the air speed has been made yet and because the "n" value is also only approximate.

A further important finding is that the B. M. normal to the plane of wing fabric is very much smaller than was estimated. Having no available data as to what these moments might be, it was assumed in the design stage that they would be of the order of 20 percent of the "in plane" bending moments. The moments produced in flight appear to be several times smaller.

At the time of this report, a study is underway to determine the division of the semi-wing loads between the keel and the leading edge. While not conclusive, the results indicate the division of load was assumed somewhat conservative for the keel. It appears that 40 percent load is carried in the keel rather than 44 percent as estimated in the design stages.

From the test analysis performed to date, it is evident that the structure has been designed adequately strong for the flight loads at a gross weight of 2,100 pounds and limit load factor of 2.0.

The maximum vertical load factor encountered during the low altitude flights was approximately 1.35 measured during gusty conditions.

Until the effect of gusts on the vertical load factor can be evaluated during flights at higher altitude, flight at maximum gross weight will not be attempted in gusty conditions.

### 3.4 Configuration Changes

As the test program progressed, several configuration modifications were incorporated. The modifications are as follows:

1. Keel doublers at the control attach points - to withstand downward bending moments encountered in ground handling.
2. Relocate control attach points on wing keel - to bring wing resultant force vector in correct relation to pivot point.
3. Reduce longitudinal CG movement range relative to longitudinal control column movement - the initial control range was found to be more than required by a factor of approximately 3.
4. Reinforce platform at landing gear attach points - to eliminate stress concentrations at platform corners.
5. Lateral CG movement control system redesign - to reduce system and structure deflection and to divide control forces between control wheel and foot pedals.

### 3.5 Existing Problem Areas

The only major problem area presently existing with respect to the test vehicle is that associated with the verification of the higher drag predicted by the latest NASA data. In order to bring the performance capabilities of the test vehicle within the range necessary to continue efficient and effective flight testing, an engine of 150-200 HP should be provided.

In conjunction with the propulsive power problem, there has existed an engine overheating condition which has not been successfully remedied by "quick fixes." This condition can be solved by adoption of an ejector cooling system similar to that successfully employed on some helicopters. The proposed system will be incorporated simultaneously with installation of a new engine.

Although lateral control of the test vehicle has been successful, the forces involved have been undesirably high. The addition of a rudder appears to have considerable merit in assisting the effect of lateral control with reduced

control forces. The fabrication of a rudder will be complete during the week of 11 June 1961.

The trailing edges of the wing have been subjected to considerable buffeting.

A solution to this problem appears to be modification of the trailing edge to a concave curve instead of a straight line as presently exists. In addition, evaluation of the material used for the wing indicates that it is marginal for long-term operational use. Cracking and peeling of the mylar coating has occurred under continued movement at the trailing edge. A new material has undergone tests which appears to be highly satisfactory for flexible wing applications.

### 3.6 Conclusions and Recommendations

The tests thus far have shown that the purpose of the contractor-sponsored flight test program to conduct flight safety and functional flight tests has been fulfilled.

It is recommended that the initial phases of the Army-sponsored program be conducted in the following manner.

1. Install rudder and perform one to two flight tests to qualitatively evaluate the rudder.
2. Install additional instrumentation, new engine and modify wing trailing edge.
3. Continue program as outlined in Report No. B02-0202.
4. When sufficient information from the modified wing is gained, install new wing with optimum configuration.

SALES BASIS: DRAG NASA METAL WING 14 MAR 60, GW = 1100 LBS  
 CURRENT TEST BED: DRAG NASA 4 APR 61, GW = 1500 LBS

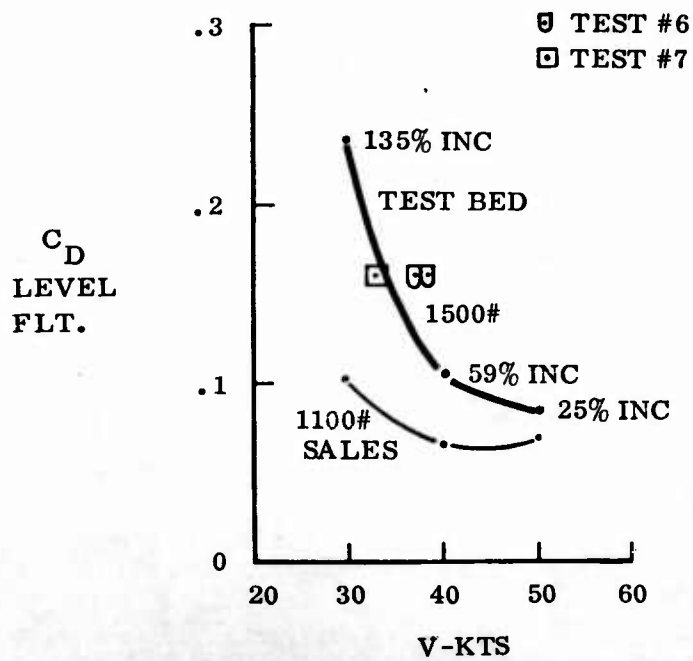
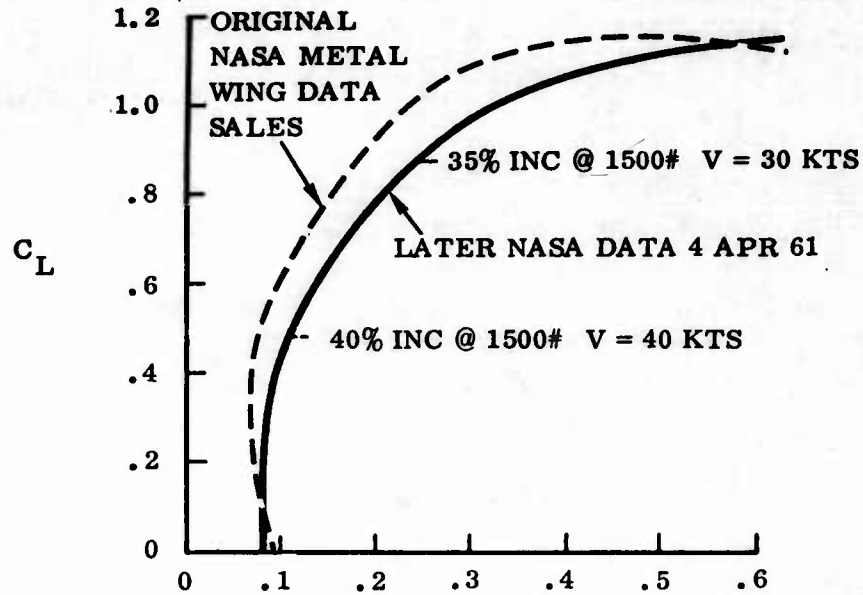

COMPARISON OF ORIGINAL SALES BASIS TO CURRENT TEST BED ESTIMATES

ESTIMATED RATE OF CLIMB  
RYAN FLEX WING TEST BED  
G.W. = 1500 LBS.  
V = 40 KTS

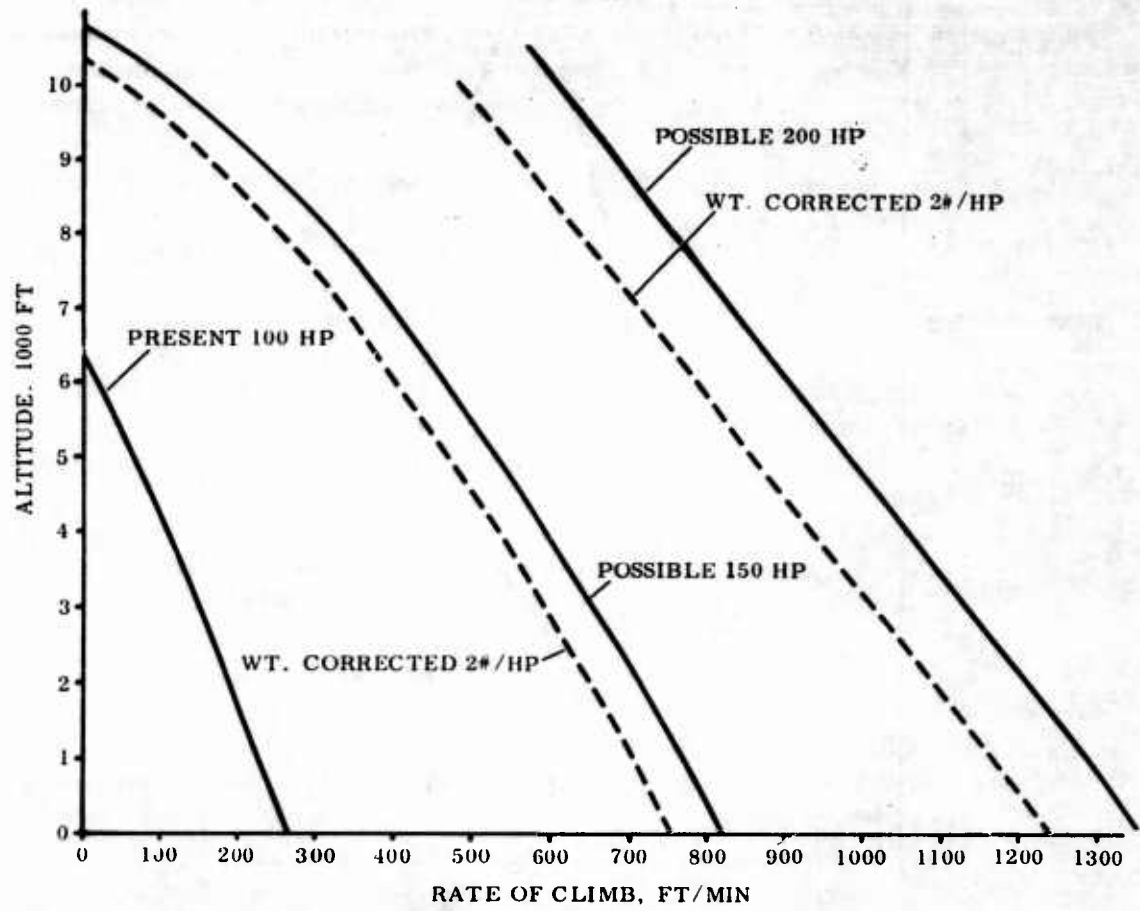

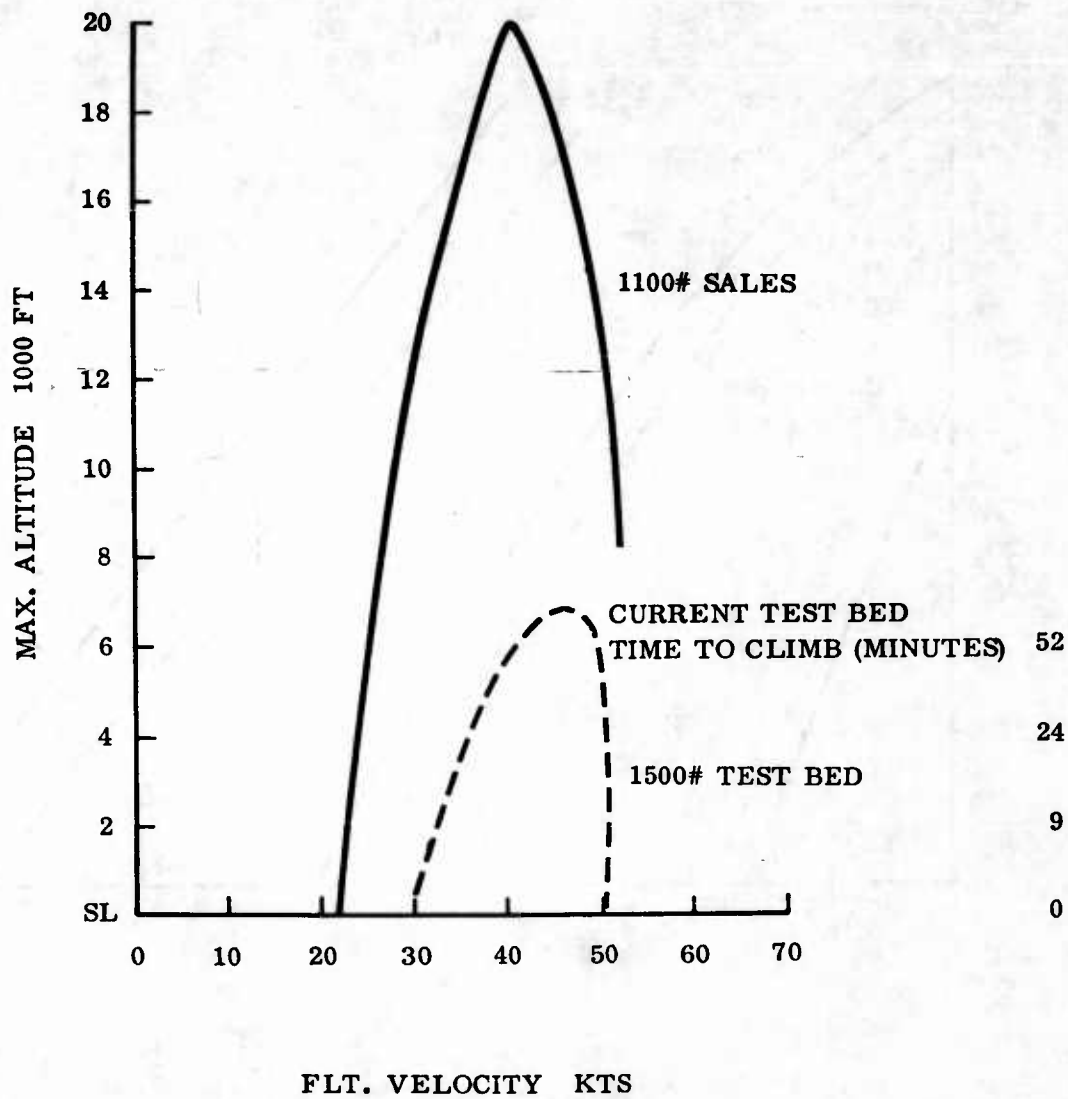

COMPARISON OF ORIGINAL SALES ENVELOP TO  
CURRENT TEST BED ESTIMATE

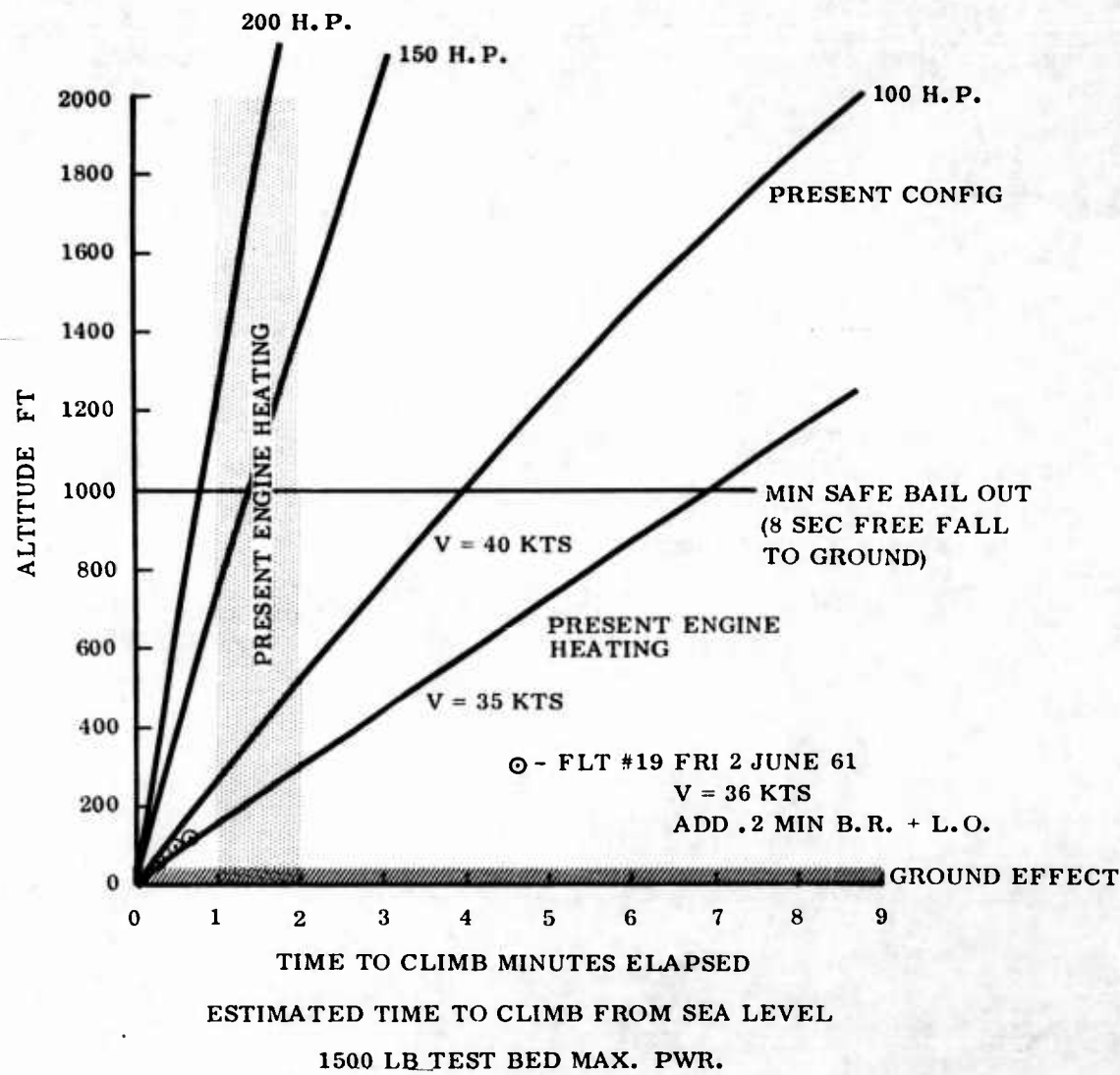

## 14.0 DISTRIBUTION

USCONARC	(2)
First US Army	(1)
Second US Army	(1)
Third US Army	(1)
Fourth US Army	(1)
Fifth US Army	(1)
Sixth US Army	(2)
USA Infantry Center	(1)
USA Command & General Staff College	(1)
Army War College	(1)
USA Arctic Test Board	(1)
USA Cold Weather and Mountain School	(1)
USA Aviation School	(2)
USA Armor Board	(1)
USA Aviation Board	(2)
USA Aviation Test Office	(1)
Deputy Chief of Staff for Logistics, DA	(4)
Deputy Chief of Staff for Military Operations, DA	(1)
The Research Analysis Corporation	(1)
ARO, OCRD	(1)
Office of Chief of R&D, DA	(1)
ARO, Durham	(1)
USA Liaison Officer, Naval Air Test Center	(2)
USA Chemical Corps Board	(1)
USA Ordnance Missile Command	(1)
USA Ordnance Board	(1)
USA Quartermaster Board	(2)
USA QM Research and Engineering Command	(4)
USA QM Field Evaluation Agency	(2)
USA Signal Board	(1)
Chief of Transportation, DA	(6)
USA Transportation Combat Development Group	(1)
USA Transportation Board	(2)
USA Transportation Materiel Command	(20)
USA Transportation Training Command	(1)
USA Transportation School	(3)
USA Transportation Research Command	(67)
USATRECOM Liaison Officer, USA Engineer Waterways Experiment Station	(1)

<b>USATRECOM Liaison Office, Wright-Patterson AFB</b>	<b>(1)</b>
<b>USATRECOM Liaison Officer, USA R&amp;D Liaison Group (9851 DU)</b>	<b>(1)</b>
<b>TC Liaison Officer, USAERDL</b>	<b>(1)</b>
<b>USATRECOM Liaison Officer, Detroit Arsenal</b>	<b>(1)</b>
<b>USA Transportation Terminal Command, Atlantic</b>	<b>(1)</b>
<b>USA Transportation Terminal Command, Pacific</b>	<b>(3)</b>
<b>USA TC Liaison Officer, Airborne, Electronic, and Special Warfare Board</b>	<b>(1)</b>
<b>USA Europe (Rear)/Communications Zone</b>	<b>(2)</b>
<b>Hq USATDS</b>	<b>(1)</b>
<b>US Army, Pacific</b>	<b>(1)</b>
<b>US Army, Alaska</b>	<b>(3)</b>
<b>Eighth US Army</b>	<b>(2)</b>
<b>US Army Transportation Agency, Japan</b>	<b>(1)</b>
<b>US Army, Ryukyu Islands/IX Corps</b>	<b>(1)</b>
<b>US Army, Hawaii</b>	<b>(3)</b>
<b>US Army, Caribbean</b>	<b>(2)</b>
<b>Allied Land Forces Southeastern Europe</b>	<b>(2)</b>
<b>Hq, AFSC (SCS-3)</b>	<b>(1)</b>
<b>APGC(PGTRI), Eglin AFB</b>	<b>(1)</b>
<b>WADD(WWAD-Library)</b>	<b>(1)</b>
<b>Air University Library</b>	<b>(1)</b>
<b>Hq USAF (AFDFD)</b>	<b>(1)</b>
<b>Air Force Systems Command</b>	<b>(3)</b>
<b>Chief of Naval Research</b>	<b>(1)</b>
<b>Bureau of Naval Weapons</b>	<b>(8)</b>
<b>Asst. Chief for Research &amp; Development (OW), Navy</b>	<b>(1)</b>
<b>US Naval Postgraduate School</b>	<b>(1)</b>
<b>David Taylor Model Basin</b>	<b>(1)</b>
<b>Hq, US Marine Corps</b>	<b>(1)</b>
<b>Marine Corps Schools</b>	<b>(3)</b>
<b>MC Liaison Officer, USA Transportation School</b>	<b>(1)</b>
<b>US Coast Guard</b>	<b>(1)</b>
<b>National Aviation Facilities Experimental Center</b>	<b>(10)</b>
<b>NASA, Washington, D. C.</b>	<b>(6)</b>
<b>George C. Marshall Space Flight Center, NASA</b>	<b>(4)</b>
<b>Langley Research Center, NASA</b>	<b>(5)</b>
<b>Ames Research Center, NASA</b>	<b>(1)</b>
<b>Lewis Research Center, NASA</b>	<b>(1)</b>
<b>Manned Space Craft Center, NASA</b>	<b>(3)</b>
<b>Library of Congress</b>	<b>(2)</b>

<b>US Army Standardization Group, U. K.</b>	<b>(1)</b>
<b>British Joint Services Mission (Army Staff)</b>	<b>(3)</b>
<b>Armed Services Technical Information Agency</b>	<b>(10)</b>
<b>Human Resources Research Office</b>	<b>(1)</b>
<b>Ryan Aeronautical Company, San Diego, California</b>	<b>(10)</b>
<b>Institute of Aerospace Sciences</b>	<b>(1)</b>
<b>USA TMC Navy Coord. Office</b>	<b>(1)</b>

Ryan Aeronautical Company, San Diego, California. Flexible-Wing Manned Test Vehicle. -- F. Landgraf, W. L. Everett, and J. H. Burch.

Report No. TCREC 62-25, March, 1962

1.58 pp. (Contract DA-44-177-TC-721 Unclassified Report)

Description and Test Results pertaining to a manned test vehicle employing the Rogallo type flexible membrane wing. Weights, design criteria, and calculated stresses in the principal wing structural members are presented, together with strain gage records of stresses in flight. Flight test data pertaining to stability and control are included. The results of various modifications to the original configuration are discussed, and recommendations toward further improvements are presented.

UNCLASSIFIED  
Flexible-Wing Manned Test Vehicle  
1. Contract DA-44-177-TC-721  
2. Unclassified Report

Ryan Aeronautical Company, San Diego, California. Flexible-Wing Manned Test Vehicle. -- F. Landgraf, W. L. Everett, and J. H. Burch.

Report No. TCREC 62-25, March, 1962

1.58 pp. (Contract DA-44-177-TC-721 Unclassified Report)

Description and Test Results pertaining to a manned test vehicle employing the Rogallo type flexible membrane wing. Weights, design criteria, and calculated stresses in the principal wing structural members are presented, together with strain gage records of stresses in flight. Flight test data pertaining to stability and control are included. The results of various modifications to the original configuration are discussed, and recommendations toward further improvements are presented.

UNCLASSIFIED  
Flexible-Wing Manned Test Vehicle  
1. Contract DA-44-177-TC-721  
2. Unclassified Report

Ryan Aeronautical Company, San Diego, California. Flexible-Wing Manned Test Vehicle. -- F. Landgraf, W. L. Everett, and J. H. Burch.

Report No. TCREC 62-25, March, 1962

1.58 pp. (Contract DA-44-177-TC-721 Unclassified Report)

Description and Test Results pertaining to a manned test vehicle employing the Rogallo type flexible membrane wing. Weights, design criteria, and calculated stresses in the principal wing structural members are presented, together with strain gage records of stresses in flight. Flight test data pertaining to stability and control are included. The results of various modifications to the original configuration are discussed, and recommendations toward further improvements are presented.

UNCLASSIFIED  
Flexible-Wing Manned Test Vehicle  
1. Contract DA-44-177-TC-721  
2. Unclassified Report

Ryan Aeronautical Company, San Diego, California. Flexible-Wing Manned Test Vehicle. -- F. Landgraf, W. L. Everett, and J. H. Burch.

Report No. TCREC 62-25, March, 1962

1.58 pp. (Contract DA-44-177-TC-721 Unclassified Report)

Description and Test Results pertaining to a manned test vehicle employing the Rogallo type flexible membrane wing. Weights, design criteria, and calculated stresses in the principal wing structural members are presented, together with strain gage records of stresses in flight. Flight test data pertaining to stability and control are included. The results of various modifications to the original configuration are discussed, and recommendations toward further improvements are presented.

UNCLASSIFIED  
Flexible-Wing Manned Test Vehicle  
1. Contract DA-44-177-TC-721  
2. Unclassified Report

Ryan Aeronautical Company, San Diego, California. Flexible-Wing  
Manned Test Vehicle. -- F. Landgraf, W. L. Everett, and J. H. Butsch.

Report No. TCREC 62-25, March, 1962  
1.58 p. (Contract DA-44-177-TC-721 Unclassified Report)

Description and Test Results pertaining to a manned test vehicle employ-  
ing the Rogallo type flexible membrane wing. Weights, design criteria,  
and calculated stresses in the principal wing structural members are  
presented, together with strain gage records of stresses in flight.  
Flight test data pertaining to stability and control are included. The  
results of various modifications to the original configuration are dis-  
cussed, and recommendations toward further improvements are pre-  
sented.

UNCLASSIFIED  
1. Flexible-Wing Manned Test  
Vehicle  
2. Contract DA-44-177-TC-721  
Unclassified Report

Ryan Aeronautical Company, San Diego, California. Flexible-Wing  
Manned Test Vehicle. -- F. Landgraf, W. L. Everett, and J. H. Butsch.  
Report No. TCREC 62-25, March, 1962  
1.58 p. (Contract DA-44-177-TC-721 Unclassified Report)

Description and Test Results pertaining to a manned test vehicle employ-  
ing the Rogallo type flexible membrane wing. Weights, design criteria,  
and calculated stresses in the principal wing structural members are  
presented, together with strain gage records of stresses in flight.  
Flight test data pertaining to stability and control are included. The  
results of various modifications to the original configuration are dis-  
cussed, and recommendations toward further improvements are pre-  
sented.

Ryan Aeronautical Company, San Diego, California. Flexible-Wing  
Manned Test Vehicle. -- F. Landgraf, W. L. Everett, and J. H. Butsch.  
Report No. TCREC 62-25, March, 1962  
1.58 p. (Contract DA-44-177-TC-721 Unclassified Report)

Description and Test Results pertaining to a manned test vehicle employ-  
ing the Rogallo type flexible membrane wing. Weights, design criteria,  
and calculated stresses in the principal wing structural members are  
presented, together with strain gage records of stresses in flight.  
Flight test data pertaining to stability and control are included. The  
results of various modifications to the original configuration are dis-  
cussed, and recommendations toward further improvements are pre-  
sented.

UNCLASSIFIED  
1. Flexible-Wing Manned Test  
Vehicle  
2. Contract DA-44-177-TC-721  
Unclassified Report

Ryan Aeronautical Company, San Diego, California. Flexible-Wing  
Manned Test Vehicle. -- F. Landgraf, W. L. Everett, and J. H. Butsch.  
Report No. TCREC 62-25, March, 1962  
1.58 p. (Contract DA-44-177-TC-721 Unclassified Report)

Description and Test Results pertaining to a manned test vehicle employ-  
ing the Rogallo type flexible membrane wing. Weights, design criteria,  
and calculated stresses in the principal wing structural members are  
presented, together with strain gage records of stresses in flight.  
Flight test data pertaining to stability and control are included. The  
results of various modifications to the original configuration are dis-  
cussed, and recommendations toward further improvements are pre-  
sented.

UNCLASSIFIED  
1. Flexible-Wing Manned Test  
Vehicle  
2. Contract DA-44-177-TC-721  
Unclassified Report

UNCLASSIFIED  
1. Flexible-Wing Manned Test  
Vehicle  
2. Contract DA-44-177-TC-721  
Unclassified Report

**UNCLASSIFIED**

**UNCLASSIFIED**