

UNCLASSIFIED

AD 284 691

*Reproduced
by the . . .*

**ARMED SERVICES TECHNICAL INFORMATION AGENCY
ARLINGTON HALL STATION
ARLINGTON 12, VIRGINIA**



UNCLASSIFIED

NOTICE: When government or other drawings, specifications or other data are used for any purpose other than in connection with a definitely related government procurement operation, the U. S. Government thereby incurs no responsibility, nor any obligation whatsoever; and the fact that the Government may have formulated, furnished, or in any way supplied the said drawings, specifications, or other data is not to be regarded by implication or otherwise as in any manner licensing the holder or any other person or corporation, or conveying any rights or permission to manufacture, use or sell any patented invention that may in any way be related thereto.

284 691

63-1-1

AFCRL -62-583

CATALOGED BY ASTIA 28469 I
AS AD NO. _____

AN EXPERIMENTAL NEGATIVE-CONDUCTANCE SLOT AMPLIFIER
AT 6 GC

M. C. Behnke
A. P. King

Hughes Aircraft Company
Culver City, California

Scientific Report No. 4

AF 19(604)-8386

July 1962

Project 4600
Task 460001

Prepared
for

ELECTRONICS RESEARCH DIRECTORATE
AIR FORCE CAMBRIDGE RESEARCH LABORATORIES
OFFICE OF AEROSPACE RESEARCH
UNITED STATES AIR FORCE
BEDFORD, MASSACHUSETTS

ASTIA
OCT 2 1962

Requests for additional copies by Agencies of the Department of Defense, their contractors, and other Government agencies should be directed to the:

ARMED SERVICES TECHNICAL INFORMATION AGENCY
ARLINGTON HALL STATION
ARLINGTON 12, VIRGINIA

Department of Defense contractors must be established for ASTIA services or have their "need-to-know" certified by the cognizant military agency of their project or contract.

All other persons and organizations should apply to the:

U. S. DEPARTMENT OF COMMERCE
OFFICE OF TECHNICAL SERVICES
WASHINGTON 25, D. C.

AFCRL -62-583

AN EXPERIMENTAL NEGATIVE-CONDUCTANCE SLOT AMPLIFIER
AT 6 GC

M.C. Behnke
A. P. King

Hughes Aircraft Company
Culver City, California

Scientific Report No. 4

AF 19(604)-8386

July 1962

Project 4600
Task 460001

Prepared
for

ELECTRONICS RESEARCH DIRECTORATE
AIR FORCE CAMBRIDGE RESEARCH LABORATORIES
OFFICE OF AEROSPACE RESEARCH
UNITED STATES AIR FORCE
BEDFORD, MASSACHUSETTS

TABLE OF CONTENTS

List of Illustrations	iii
Abstract	iv
Introduction	1
The Tunnel Diode Amplifier	2
The Slot Amplifier Circuit	5
Conclusions	10
The Noise Performance of Negative Conductance Amplifiers	11
Introduction	11
Thermal Noise Considerations	11
The Reflection Amplifier	15
Tunnel Diode Shot Noise	17
Conclusions	19
References	20

LIST OF ILLUSTRATIONS

Figure 1.	The mounting plate with tunnel-diode resonant-slot amplifier (at 6 gc) as employed in the simultaneously scanned antenna array	3
Figure 2.	A section of the waveguide broadwall has been cut away and replaced by diode amplifier mounting plates. The individual resonant slot antenna and its diode amplifier is matched to the waveguide by two adjustments: by sliding the mounting plate to vary d_s , and sliding the piston position d_p relative to the resonant slot	4
Figure 3.	Equivalent circuit of tunnel diode	6
Figure 4.	Equivalent circuit of slot near resonance. Network N transforms parallel arrangement at A - A' to series RLC circuit at B - B'. This is then connected in shunt with feed waveguide.	6
Figure 5.	Equivalent circuit of slot antenna with tunnel diode. Transformer T provides a match of the low impedance tunnel diode to the slot	6
Figure 6.	Three forms of negative-conductance slot amplifiers (6 gc). (A) Strip line biasing lead, (B) coaxial line biasing lead, and (C) a shielded strip line	8
Figure 7.	Resistance R_i with its associated noise voltage generator e_n^2 impedance matched to transmission line. R_L is the termination to the line. ($R_L = R_i$)	13
Figure 8.	The negative conductance amplifier with an input conductance which matches transmission line L_1 and a load conductance g_L matches transmission line L_2 . An isolator is connected as shown in line L_2 . A negative conductance $-g$ is connected at the junction of the two lines L_1 and L_2 of generally different conductances.	13
Figure 9.	The negative conductance amplifier in connection with a circulator. The available thermal noise power P_n' (from g_L) is dissipated in the matched arm 4 and isolated from the diode amplifier	16

ABSTRACT

This report describes an experimental study of a tunnel diode amplifier. The purpose of this device was to provide signal gain for the slot elements employed in an experimental simultaneously scanned antenna array. Each slot element comprised a resonant slot coupled to the waveguide broadwall. The diode was asymmetrically placed in the slot to transform the diode impedance to that of the antenna slot. Some of the attractive features of this type amplifier include design simplicity, light weight, and with suitable circuitry a low noise figure. These devices are relatively radiation resistant and offer possibilities for future consideration in space vehicle application.

Experimental results at 6 kmc have yielded gains in excess of 15 db with commercially available diodes. Tunnel diodes capable of operating at frequencies of 10 kmc and higher are beginning to appear on the market. With suitable circuitry a lower noise figure than obtained with a conventional balanced crystal converter can be expected. Noise figures in the 5-7 db range at frequencies up to 10 kmc can be obtained with the use of circulators. Some consideration of the noise problem with tunnel diodes is included.

INTRODUCTION

Part I of this report describes an experimental study of a tunnel diode slot amplifier which was developed for use in an experimental Simultaneously Scanned linear array¹. The use of signal amplification for the individual elements of the array is especially attractive for signal processing antennas whose signal level and noise figure are usually impaired by the signal processing. Recent experiments indicate that gains can be realized which more than offset the signal loss as a result of the signal processing and that improvement in the noise figure can be expected. An additional essential feature of the tunnel diode as used with signal processing antennas is that it can be employed as an extremely fast switch to cut off the amplifier². This report will only consider the negative conductance slot amplifier.

Part II of this report briefly considers the noise problems which are more or less indigenous to bilateral negative conductance devices. In order to realize a moderately low noise figure for this mode of operation, the diode must be operated under mismatched conditions, usually at the input to the amplifier. Low noise figures in the 5 db to 7 db range, can be obtained with the tunnel diode operating as a unilateral amplifier with a circulator³.

THE TUNNEL DIODE AMPLIFIER

The experimental study of the slot amplifier is a continuation of an earlier study⁴. In that analysis an adequate theory of the endplate slot was developed and the conditions necessary for the asymmetric mounting of the diode element in the slot were employed. These basic principles are employed in the experimental work described below.

The tunnel diode (Sylvania type D4168C) is mounted in a slot cut in a .1 inch thick brass plate as shown in Figure 1. The diode is placed in the slot near one end at a position which provides an impedance match of the diode to the resonant slot. An anodized aluminum post clamps the diode in place and also provides the insulated terminal for biasing and switching purposes. The slot is designed to resonate at a frequency higher than the operating frequency of 6 Gc. Under these conditions the slot is inductive and is tuned by an appropriate shunt capacitive component across the center of the slot by means of a threaded tuning screw. Five antenna amplifier elements were assembled and mounted on a common waveguide as shown in Figure 2. This arrangement has several attractive features; the adjustment of the distance of the slot to the side wall of the waveguide provides an additional degree of freedom in matching the slot-diode impedance to that of the rectangular waveguide, the alternate elements of the array are staggered on opposite sides of the waveguide broadwall to provide the proper phasing at $\frac{\lambda}{2}$ intervals, and the same position of the tuning piston will match any one of the five array elements. This arrangement provides a convenient and simple method of connecting the elements to a common waveguide.

The configuration considered here differs from that treated previously⁵ in that the tunnel diode is now placed in a longitudinal shunt slot (instead of in an endplate series slot); also, the diodes available for this study have negative resistances very different than those previously used. The diodes used in the experiments described in this report have negative resistances in -50 to -70 ohm (-g in the .014-.02 mho) range. For a half-wave resonant slot a maximum resistive impedance of 480 ohms is developed across the center of the slot and a tunnel diode with a negative resistance of 480 ohms placed symmetrically in this position would match the slot impedance.

The value of 480 ohms assumes that the slot radiates into free space on both sides. However, in the configuration used one side couples into the waveguide. The amount of coupling depends on its displacement from the waveguide centerline. In this case it may vary from approximately 495Ω to 974Ω . (974Ω on centerline, 495Ω at maximum displacement with "open circuit" on one end of guide and match on other end.) Other guide loading conditions will result in different limits on R. A diode of lower impedance, say $R_d = 60$ ohms, can be matched by placing the diode in an asymmetric position across the slot in accordance with the following relation:

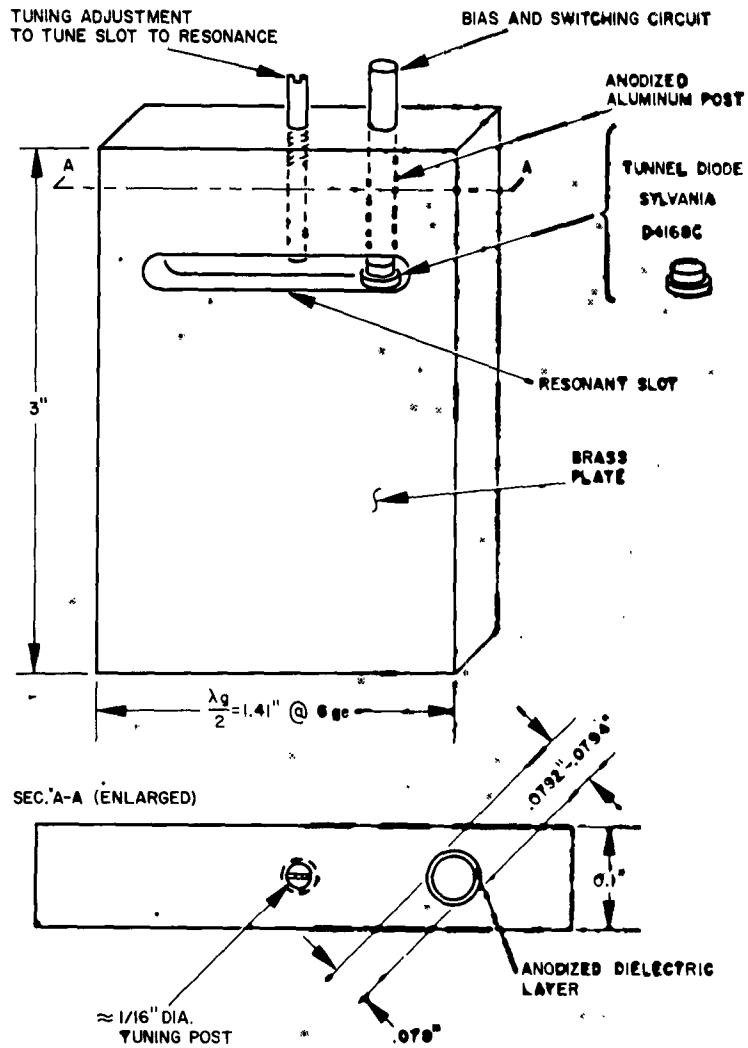

Figure 1. Mounting plate with tunnel-diode resonant-slot amplifier (at 6 gc) as employed in the simultaneously scanned antenna array.

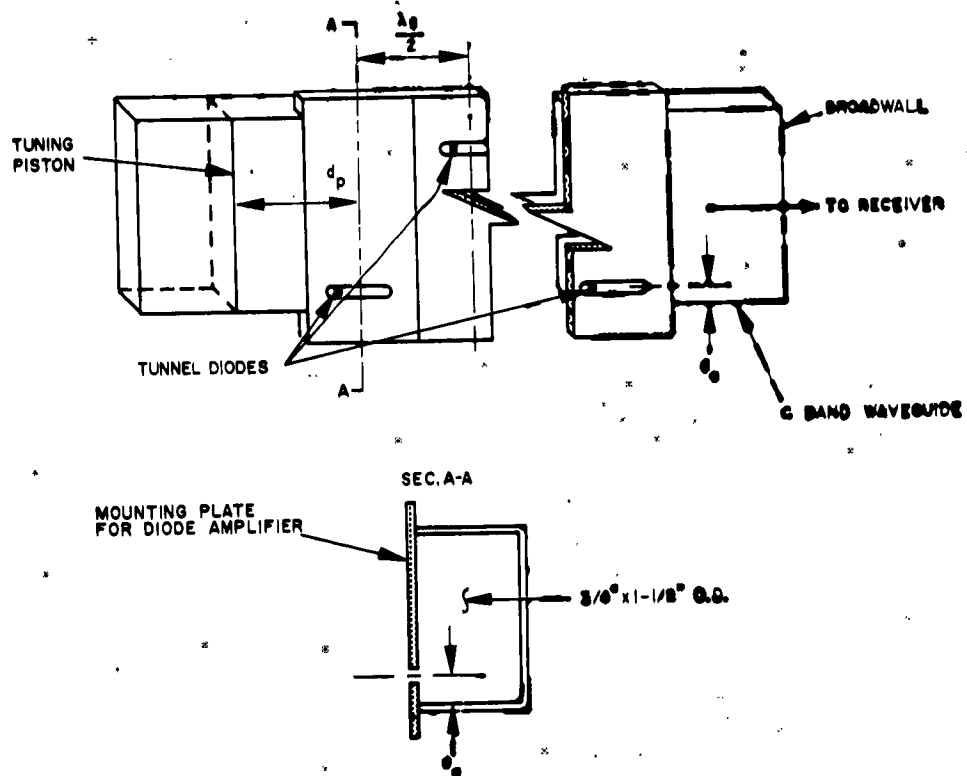

Figure 2. A section of the waveguide broadwall has been cut away and replaced by diode amplifier mounting plates. The individual resonant slot antenna and its diode amplifier is matched to the waveguide by two adjustments: by sliding the mounting plate to vary d_s and sliding the piston position d_p relative to the resonant slot.

$$R_d = R_s \sin^2 \left(\frac{\pi}{2} \frac{d}{L} \right) \quad (1)$$

where R_d is the value of resistance to be matched, $R_s = 480$ ohms which is the impedance across the center of the slot, d the distance of the diode from the end of the slot and $2L$ the length of the slot. For $R_D = 60$ ohms, $2L = .760''$, the value of d in (1) is $.08''$ which corresponds to the position determined empirically. The actual circuit employed an asymmetrically placed diode whose negative resistance and junction capacitance had variations from unit to unit. By selecting tunnel diodes a good match between the resonant slot antenna and the waveguide was obtained by experimental means.

To produce this match the following parameters were adjusted: the length of slot and tuning stub, the diode position in slot, the slot position (slot is approximately $1/8$ inch from sidewall in the broadwall of the guide), the position of the movable short in the waveguide

$$\left(d_P = (2n+1) \lambda_g / 4 \right)$$

THE SLOT AMPLIFIER CIRCUIT

This section describes the circuitry employed for the resonant slot-tunnel diode amplifier. The difficulties encountered with an early design and its modification to the unit employed in the experimental array are considered and a model for future consideration is proposed.

The equivalent circuit⁶ of the tunnel diode is shown in Figure 3 where r is the base resistance, C_d the junction capacitance, R_d the negative resistance and L the series inductance of the leads. The equivalent circuit⁷ of a shunt slot near resonance is shown in Figure 4 where L_s is the slot inductance, C_s the slot capacitance and R_s the resistive impedance at the center of the slot. The impedance of the transformation network N matches the resonant slot to the waveguide terminal BB' . The addition of the tunnel diode to this circuit results in the equivalent circuit shown in Figure 5. The transformer T represents the impedance transformation to provide an impedance match of the diode to the resonant slot circuit. The transformation ratio, R_s/R_d , is approximately 10, and is obtained by placing the diode asymmetrically in the slot. As stated previously, this placement was determined experimentally, which agrees closely with the computations using equation (1). The terminals CC' are the connections to the biasing lead to provide a diode potential of about 0.25 volts at 2-3 milliamperes for operating the tunnel diode in a suitable negative conductance region;⁷ For selected Sylvania tunnel diodes (Type D4168C) the range of negative resistance was found to lie in the -50 to -70 ohm range. The presence

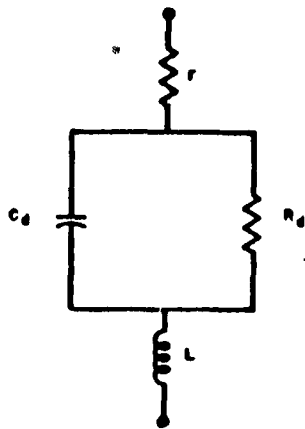

Figure 3. Equivalent circuit of tunnel diode.

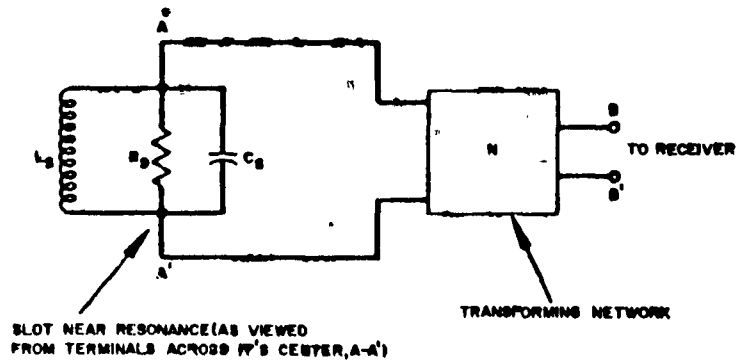

Figure 4. Equivalent circuit of slot near resonance. Network N transforms parallel arrangement at A-A' to series RLC circuit at B-B'. This is then connected in shunt with feed waveguide.

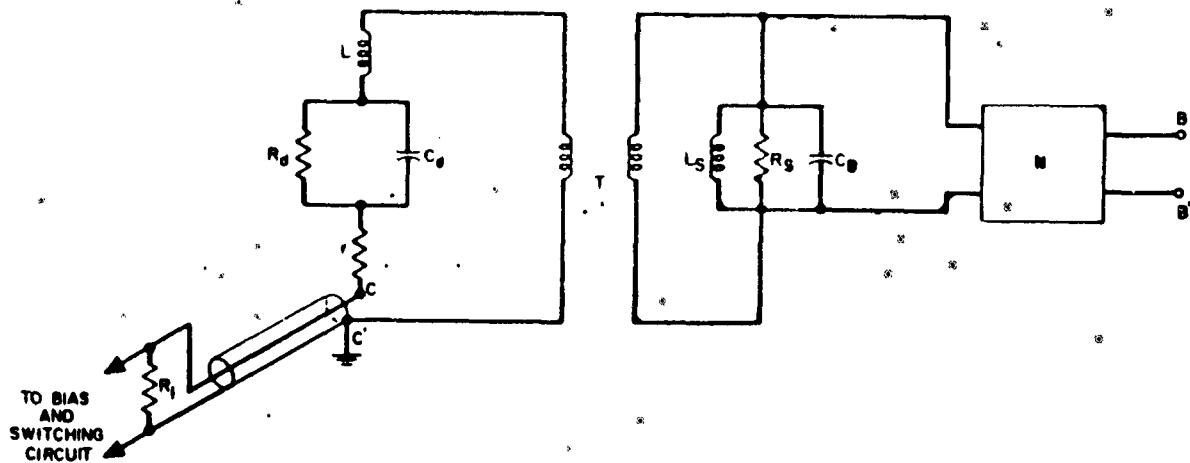

Figure 5. Equivalent circuit of slot antenna with tunnel diode. Transformer T provides a match of the low impedance tunnel diode to the slot.

of a low resistance $R_i \approx 10$ ohms, serves to damp out low frequency oscillations due to the distributed capacity and inductance of the bias leads. For the microwave circuit these leads should present a very low impedance at CC', preferably a short circuit. A reactive impedance, $Z = r \pm jx$, at this point can give rise to parasitic oscillations outside the passband and may affect the bandwidth and the stability of the amplifier. The structure for the biasing lead should be such as to introduce a very low impedance with a minimum loss and negligible reactive effects upon the RF circuit. Below are discussed several bias lead structures.

Three versions of the resonant slot-tunnel diode amplifier structure are shown in Figure 6. These units differ principally in the arrangement of the bias leads. In Figure 6 (A) is an earlier version, (B) is the design employed for the tests described in this report and (C) an alternate form of a model B. In all models the central threaded post (shown to the left of 6B) provides a tunable shunt capacitance at the center of the slot which is adjusted to resonate the slot. In A and B the post is brass, for C a dielectric tuning post is planned. The bias leads are shown at the right end of the slot where the diode is located.

In Figure 6 (A) the bias lead is a strip-transmission line. This is mounted on Scotch Cellulose adhesive tape which is threaded through the slot and attached on each side of the plate. This tape forms the dielectric of the strip line which is mounted over the tape at a position in the slot corresponding to the location of the tunnel diode unit. On the side shown the tape extends beyond the metal plate, the aluminum tab is the insulated connection to the diode. The length of the aluminum tape on the other side of the plate is trimmed in length to provide maximum gain which occurs for lengths corresponding to an odd number of quarter wavelengths, preferably $\frac{\lambda_d}{4}$, where λ_d is the guide wavelength in the strip line. This section of the tape line employs the well known impedance transformation, i. e., it has a high impedance at the open end and a low impedance at the diode relative to the brass plate at the operating frequency of 6 gc. The diode is mounted to bridge the slot, so that one of its terminals contacts the insulated tape and the other terminal makes contact to the brass plate. Widths of the aluminum strip in the 1/8 inch to 1/4 inch range worked equally well, the narrower tape provided sufficient range of adjustment in positioning the diode along the slot. It was found, however, that a tape 1/2 inch wide lowered the maximum gain by several db. For all tape widths the length of the strip was very critical, variations of over 30 db in transmission were observed while adjusting the length and difficulty was experienced in reproducing the maximum gain more closely than within 2 or 3 db for a given tunnel diode. The uncertainty of the losses in the strip line (even at optimum gain), the exposed nature of the external line and the fitting of the tunnel diode in the slot (often requiring metal shims to wedge the diode in place) has led to the alternate form of biasing lead described below.



Figure 6. Three forms of negative-conductance slot amplifiers (6 gc). (A) Strip line biasing lead, (B) coaxial line biasing lead, and (C) a shielded strip line.

The coaxial line type of biasing lead is shown structurally in Figure 1 and in the photograph of Figure 6 (B). The inner conductor comprises an aluminum post (shown at right of Figure 6 (B)) .078 inch in diameter. An aluminum oxide coating approximately .0005 inch in thickness provides the dielectric of the coaxial lead. This anodized post slides in a close fitting hole in the brass mounting plate near one end of the slot. The end of the post is threaded in a nylon bushing and provides the means to make contact to the diode and to clamp it in place. The capacitance between the conductors of this coaxial line, which is 1 inch long, lies in the 400 to 200 picofarad range for radial air clearance of the anodized post in the .0002 inch to .0004 inch range respectively. The resistive impedance R_L of this coaxial line is

$$Z = R_L = \frac{59.8}{\sqrt{\epsilon}} \ln \frac{r_2}{r_1} \quad (2)$$

where ϵ is the relative dielectric constant of the aluminum oxide ($\epsilon = 8$ approximately), $r_1 = 0.039$ inch is the inner radius and $r_2 = 0.0396$ inch the outer radius. For these values the impedance of the coaxial line is approximately 0.3 ohms.

As shown in Figure 5, the coaxial line impedance can be replaced by a 0.3 ohm resistance across terminals CC' and is in series with the relatively much higher resistances $r = 5-10$ ohms and $R_d = -50$ to -70 ohms. This is desirable in order to minimize the external circuit losses due to the RF current flow in the tunnel diode circuit. For the above values of r and R_d the circuit power loss in the bias lead circuit is very small, less than one-tenth percent. In the circuit analysis, the value r can be replaced by $r' = r + R_L = 5 + 0.3 = 5.3$ ohms in the above case. The measured Q of the coaxial line biasing lead was less than 5 and the dissipation factor ($1/Q$) was greater than 0.2 at 1 Kc. According to Von Hippel⁹ the loss in the dielectric is even higher at 6 gc, the operating frequency of the tunnel diode amplifier. Thus with a very low Q , the line length and resonance effects are negligible and the line can be considered to be aperiodic with frequency. From an electrical point of view the circuit has been stable and free from spurious responses over a wide band.

Some difficulties have, however, occurred in the fabricating of the coaxial line. The major difficulty has been the precision with which the hole can be drilled; in some cases the hole was so large that the air gap surrounding the anodized inner lead of the coaxial line was greater than the thickness of the oxide-dielectric layer. Under those conditions, the capacity of the line is determined largely by the air separation which lowers the effective dielectric constant to that approaching the value for air ($\epsilon = 1$) and the dissipation is decreased so that the effective Q is greater than 5. These conditions increase the coaxial line impedance, decrease its losses, and increase the possibility of introducing undesirable line length and resonance effects. These large

clearances were largely avoided by selecting and individually fitting the posts for a good fit in the hole. An alternative structure, shown in Figure 6(C) was tried. The latter replaced the round rod with an .025 inch by 1/8 inch wide anodized strip which was fitted in a milled groove of the mounting plate. In the few models constructed this type indicated that closer tolerances could be held. It will be seriously considered in the design of future models.

CONCLUSIONS

The further development of resonant slot-tunnel diode amplifiers as antenna elements in a simultaneously scanned array indicates that gains of 15 db and higher are feasible. It is expected that through further circuit studies and the use of more suitable tunnel diodes the above factors can be materially increased.

THE NOISE PERFORMANCE OF NEGATIVE CONDUCTANCE AMPLIFIERS

INTRODUCTION

The noise problem associated with negative resistance amplifiers, particularly of tunnel diodes, is a subject of considerable current interest. Experimental results obtained with this type amplifier have been reported at frequencies up to 10 gc with bandwidths of at least 10 percent. Tunnel diodes capable of amplifying at higher frequencies are currently available.¹⁰ These devices because of their bilateral nature require special circuits to realize the lowest noise figures.^{8, 11}

The negative resistance amplifier assumes two general forms. In one configuration the amplifier is a two terminal pair network and behaves as a bilateral device. When the amplifier is employed in this manner the thermal noise generated in the output circuit can be amplified along with the signal and add to the noise generated by the diode. Under these conditions the presence of amplified thermal noise seriously degrades the noise figure. It has been proposed that a lower noise figure can be obtained by operating the bilateral amplifier with the input circuit mismatched.¹² The lowest noise figures have been achieved with circuits which employ circulators to convert the amplifier to a unilateral device. When operated in this manner the output circuit is isolated from the input circuit and there is no amplification of the output circuit thermal noise. It is with the unilateral amplifier, which is widely reported in the technical literature, that low noise figures in the range of 5 - 7 db at 10 gc have been reported.^{3, 10, 13}

The following sections will describe the noise performance of the tunnel diode amplifier, both for the unilateral and the bilateral case with an isolator in the output circuit. The influence of the diode parameters upon the noise figure will be included.

THERMAL NOISE CONSIDERATIONS

The following analysis will make use of traveling waves on transmission lines.¹⁴ This approach has the advantage that it employs distributed circuits (waveguides, etc.) which are used more commonly in the high frequency circuitry of the amplifier. Also, this mode of treatment provides a clear and unambiguous physical picture of thermal noise behavior. This form of analysis is quite general, since the transmission line method can also be applied to lumped circuit analysis by reducing the length of transmission line to zero.

Consider in circuit of Figure 7 with resistance R_i at temperature T in degrees Kelvin. The Johnson or thermal noise (mean-square voltage) across its terminals is

$$e_n^2 = 4 K T R \text{ (per unit bandwidth)} \quad (3)$$

where K is the Boltzmann constant. The maximum available noise power P_n per unit bandwidth in Figure 7 is

$$P_n = \frac{e_n^2}{4R_i} = K T \text{ (per unit bandwidth)} \quad (4)$$

The noise voltage (Figure 7) can be replaced by its Thevenin equivalent, a shunt noise current generator. Again, the noise generated across R_i is

$$P_n = \frac{i_n^2 R_i}{4} = K T \text{ (per unit bandwidth)} \quad (5)$$

The schematic of the transmission type amplifier which will be considered is shown in Figure 8. The input conductance g_i at temperature T_1 matches transmission line L_1 to the left of the negative conductance ($-g$) and g_L the load conductance at temperature T_2 matches transmission line L_2 to the right of the negative conductance. An isolator,¹² with no forward loss and infinite reverse loss at temperature T_1 is inserted in L_2 between the negative conductance and the load conductance. It is further assumed that the noise from the tunnel diode, represented by noise generator i_n^2 is connected in shunt with the negative conductance. The negative conductance and its associated noise current generator is connected at the junction of the two transmission lines L_1 and L_2 . These lines are of generally different conductances g_i and g_L . For the circuit of Figure 8 there are two power reflection coefficients P_i and P_L for signals (or noise) approaching $-g$ from g_i and g_L respectively. P_T is the diode gain factor or power transmission coefficient¹⁵ traversing $-g$ in either direction.

On this basis one can write

$$P_i = \left(\frac{g_i - g_L + g}{g_i + g_L - g} \right)^2$$

$$P_L = \left(\frac{g_L - g_i + g}{g_i + g_L - g} \right)^2$$

$$P_T = \frac{4g_i g_L}{(g_i + g_L - g)^2} \quad (6)$$

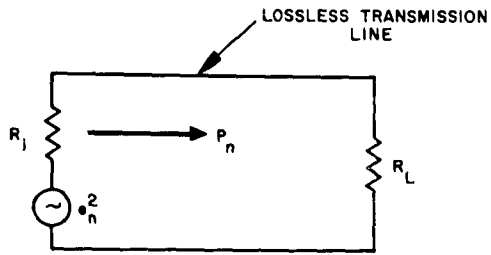

Figure 7. Resistance R_1 with its associated noise voltage generator e_n^2 impedance matched to transmission line. R_L is the termination to the line. ($R_L = R_1$)

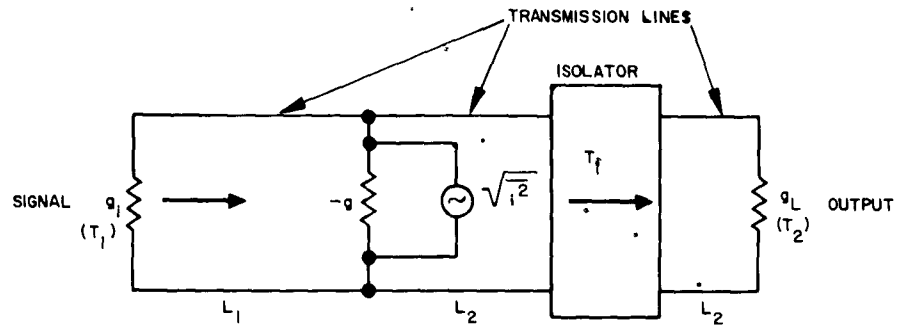

Figure 8. Negative conductance amplifier with an input conductance which matches transmission line L_1 and a load conductance g_L matches transmission line L_2 . An isolator is connected as shown in line L_2 . A negative conductance $-g$ is connected at the junction of the two lines L_1 and L_2 of generally different conductances.

In addition to the noise generated by the negative conductance device the following sources of thermal noise must be considered in order to evaluate the overall noise performance of the amplifier: g_i at T_1 and the isolator conductance at T_1 . Since KT_1 watts per unit bandwidth flow from g_i and g_L toward the negative conductance, the noise power per unit bandwidth incident upon g_L , the load conductance, is

$$N = KT_1 P_T + KT_1 P_L + i^2 \frac{g_L}{(g_i + g_L - g)^2} \quad (7)$$

The input signal at g_i and traveling toward $-g$ receives a gain P_T and thus the noise factor, NF , at $T_1 = 290^\circ$, is given by

$$NF = 1 + \frac{P_L}{P_T} + \frac{i^2}{KT_1 P_T} \left[\frac{g_L}{(g_i + g_L - g)^2} \right] \quad (8)$$

This is the noise factor of the transmission amplifier. Substituting from equations in (6) this expression becomes

$$NF = 1 + \frac{(g_L - g_i + g)^2}{4g_i g_L} + \frac{i^2}{4KT_1 g_i} \quad (9)$$

Under the conditions of operation as indicated in Figure 8 the noise generated in the isolator termination contributes to the noise figure but the noise generated in the load conductance g_L does not. Two terms contribute to the noise figure. The second term in equation (9) is due to the hot isolator termination which can be eliminated by setting

$$g_L = g_i - g \quad (10)$$

This is simply the cancellation of component P_L making $P_L = 0$. Thus it is apparent that improved noise factors can be obtained by operating under mismatch conditions¹⁴. Under these conditions the substitution of (10) reduces equations (6) to equations (11), shown below

$$P_i = \left(\frac{g_i}{g_L} \right)^2$$

$$P_L = 0 \tag{11}$$

$$P_T = \frac{g_i}{g_L}$$

There appears to be a total lack of experimental data reported in the literature to indicate how closely this condition can be realized with stable amplification, or the improvement in noise figure which can be achieved. Most workers appear to have chosen circulators to obtain the lowest noise figures. This approach will be briefly described below.

THE REFLECTION AMPLIFIER

Since the use of a circulator to convert the transmission amplifier into a unilateral amplifier to minimize the contribution of thermal noise is amply covered in the literature^{3, 10, 13}, only the general behavior will be described. Figure 9 shows, in elementary form, a negative conductance device in conjunction with a circulator. This is a unilateral amplifier.

The thermal noise $P_n = KT_1$ generated in the input conductance, g_i , travels as indicated by the solid line, in the direction indicated by the arrows, to arm 2 of the circulator, is amplified (along with the input signal) by the negative conductance and travels to the output terminals to conductance, g_L , in arm 3 of the circulator. The noise power (generated in the output conductance g_L) $P'_n = KT_2$, travels along the path indicated by the dotted lines and is match terminated in arm 4 of the circulator. This source of noise is isolated and does not reach the negative conductance in arm 2. In this circuit the interacting effects of output noise with the negative conductance, which would degrade the noise figure, have been avoided.

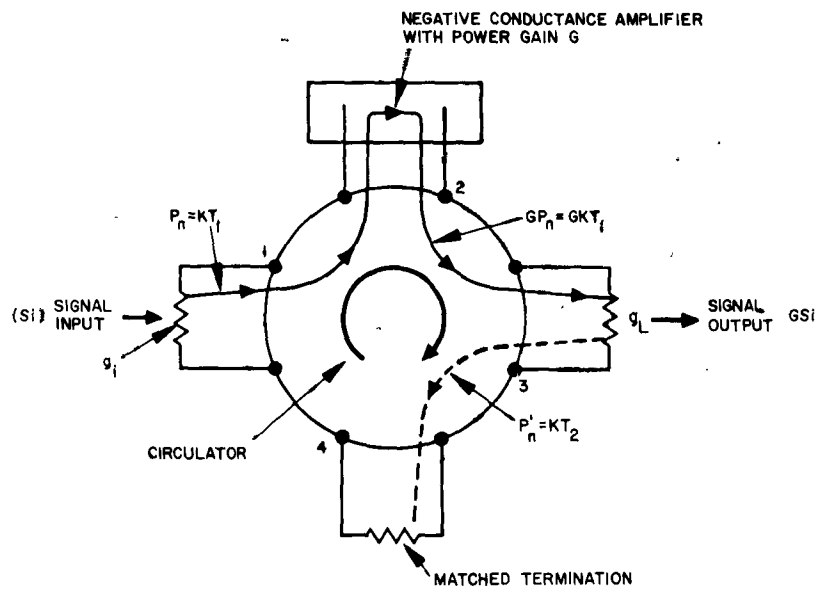

Figure 9. The negative conductance amplifier in connection with a circulator. The available thermal noise power P'_n (from g_L) which is dissipated in the matched arm 4 and isolated from the diode amplifier.

TUNNEL DIODE SHOT NOISE

As mentioned previously a shunt noise current (Fig. 8) is associated with the tunnel diode. This is the shot noise¹⁶ indicated by the last term in equations (7), (8), (9). For an amplifier of the unilateral type used with a circulator (Fig. 9) the shot noise is usually the major contribution to the noise figure. Some circulator and associated circuit losses are present and the analysis of the amplifier under these conditions has been treated extensively in the literature^{3, 6, 8, 13}. However in a well designed amplifier these losses are quite small so that the noise figure as a function of the tunnel diode parameters alone can be used to provide a fairly close approximation to the noise figure.

On this basis the noise figure¹⁷ of a tunnel diode can be written

$$NF = \frac{1 + G_e R_D}{\left(1 - \frac{r}{R_D}\right) \left[1 - \left(\frac{f}{f_c}\right)^2\right]} \quad (12)$$

where

$$G_e = \frac{eI_o}{2KT}$$

e = electronic charge = 1.6×10^{-19} coulombs

I_o = tunnel diode current in amperes

K = Boltzmann Constant = 1.38×10^{-23}

T = absolute temp in degrees Kelvin = $290^\circ K$

r = base or spreading resistance

R_D = negative resistance of the diode

f = operating frequency

$$f_c = \text{cut off frequency} = \frac{1}{2\pi R_D C_J} \sqrt{\frac{R_D}{r} - 1}$$

C_J = junction capacity

Substitution of above values simplifies (12) to

$$NF = \frac{1 + 20 I_0 R_D}{\left(1 - \frac{r}{R_D}\right) \left[1 - \left(\frac{f}{f_c}\right)^2\right]} \quad (13)$$

In this expression the diode current I_0 is determined by the biasing voltage E which is about two-tenths of a volt. A maximum dynamic range of the signal is achieved at or near the center of the linear portion of the negative slope of the EI curve. Even so the power handling capabilities are very limited, especially for diodes operating at frequencies as high as 5-10 gc. Powers of 10^{-6} to 10^{-8} watts are characteristic. Once the operating point is chosen for I_0 , the slope at I_0 also determines the value of negative resistance R_D . The remaining values R_B and f_c are characteristics of the individual diode.

In tunnel diode designed to provide a low noise figure at say 6 gc the parameters lie in the range indicated below:

$$I_0 = .5 - 1.0 \times 10^{-3} \text{ amperes}$$

$$R_D = -50 \text{ to } -100 \text{ ohms}$$

$$r = 5 - 10\% \text{ of } R_D$$

$$f_c = 2 - 4 \text{ times the operating frequency } f.$$

Choosing the median values of the above, the resulting noise figure is

$$NF = 4.5 \text{ db}$$

This result is in reasonable agreement with the overall noise figures quoted in the literature^{10, 11}, operated as a unilateral amplifier with a circulator.

It is of interest to compare the above results with the Sylvania diodes (Type D4168G) which were employed in the five element simultaneously scanned antenna array². One of the elements with a typical

diode indicated a high noise figure of 14.2 db. The characteristics of this tunnel diode are listed below:

$$I_o = 2.65 \times 10^{-3} \text{ amperes}$$

$$R_D = -57 \text{ ohms}$$

$$f = 6 \text{ gc}$$

$$f_c = 7.7 \text{ gc (measured by mfg.)}$$

$$C_j = 1.6 \text{ pf .}$$

The noise figure due to shot noise, using equation (13) gives

$$NF = 9.7 \text{ db .}$$

This high shot noise contribution is due principally to the high operating current I_o and the low cut off frequency f_c . This value can be at least halved by the use of tunnel diodes operating at currents of one milliamperes or less and with a cut off frequency three to four times the operating frequency. The difference between the measured noise figure and the calculated value due to shot noise ($14.2 - 9.7 = 3.5 \text{ db}$) is attributed to circuit losses and the interaction of thermal noise from the isolator termination in the amplifier.

CONCLUSIONS

The use of more suitable tunnel diodes with lower shot noise levels and improved waveguide circuitry, and the reduction of thermal noise through the use of mismatched circuits as indicated by equation (11) is expected to yield substantial improvements in the noise figure. It is probable, however, that the lowest noise figure and greater circuit flexibility, will be realized with the tunnel diode operated as a unilateral amplifier in conjunction with a circulator.

REFERENCES

1. "Simultaneously Scanned Antenna Systems" (Confidential) Report P62-17, Final Report, Contract AF 19(604)-8006, April 1962.
2. Reference 1, pp. 22-27; pp. 57-60.
3. R. F. Trambarulo, "A Low-Noise X-Band Esaki Diode Amplifier," 1962 International Solid State Conference, Vol. V, pp. 72-73.
4. Pedinoff, M. E., "The Negative-Conductance Slot Amplifier," IRE Trans. MTT, Vol. MTT-9, No. 6, November 1961, pp. 557-566. Also Scientific Report No. 3, Contract AF 19(604)-8386, AFCRL 920, May 1961.
5. Reference 4, pp. 557-565.
6. H. S. Sommers, Jr., "Tunnel Diodes as High Frequency Devices," Proc. IRE, Vol. 47, pp. 1201-1206, July 1959.
7. Reference 4, p. 559.
8. M. E. Hines, "High Frequency Negative-Resistance Circuit Principles for Esaki Diode Applications," BSTJ, Vol. 39, pp. 477-513, March 1960.
9. Von Hippel, "Table of Dielectric Materials," Tech. Report 119, MIT, Vol. V, pp. 3, 4.
10. N. E. Chasek, "System Application of Tunnel Diode Amplifiers," International Microwave Corporation, Cos Cob, Connecticut, Bulletin 54-562, 1962.
11. M. E. Hines and W. W. Anderson, "Noise Performance Theory of Esaki (Tunnel) Diode Amplifiers," Proc. IRE, Vol. 48, p. 789, April 1960.
12. H. A. Haus and R. B. Adler, Circuit Theory of Linear Noisy Networks, (John Wiley and Sons, Inc., New York, N. Y., 1959) pp. 68-71.
13. K. K. N. Chang, "Low Noise Tunnel-Diode Amplifier," Proc. IRE, Vol. 47, pp. 1268-1269, July 1959.
14. A. E. Siegman, "Thermal Noise in Microwave Systems," Microwave Journal, Vol. 4, pp. 81-90, March 1961.

15. G. Schaffner, "A Compact Tunnel-Diode Amplifier for Ultra-High Frequencies," IRE Convention Record, Vol. 4, Part 2, pp. 86-93, 1960.
16. J.J. Tiemann, "Shot Noise in Tunnel Diode Amplifiers," proc. IRE, Vol. 48, pp. 1418-1423, August 1960.
17. E.G. Nielson, "Noise Performance of Tunnel Diodes," Proc. IRE, Vol. 48, pp. 1903-1904, November 1960.