

UNCLASSIFIED

AD **285 473**

*Reproduced
by the*

ARMED SERVICES TECHNICAL INFORMATION AGENCY
ARLINGTON HALL STATION
ARLINGTON 12, VIRGINIA



UNCLASSIFIED

NOTICE: When government or other drawings, specifications or other data are used for any purpose other than in connection with a definitely related government procurement operation, the U. S. Government thereby incurs no responsibility, nor any obligation whatsoever; and the fact that the Government may have formulated, furnished, or in any way supplied the said drawings, specifications, or other data is not to be regarded by implication or otherwise as in any manner licensing the holder or any other person or corporation, or conveying any rights or permission to manufacture, use or sell any patented invention that may in any way be related thereto.

**BLANK PAGES
IN THIS
DOCUMENT
WERE NOT
FILMED**

63-1-1

285 473

285473

CATALOGED BY ASTIA
AS AD NO.

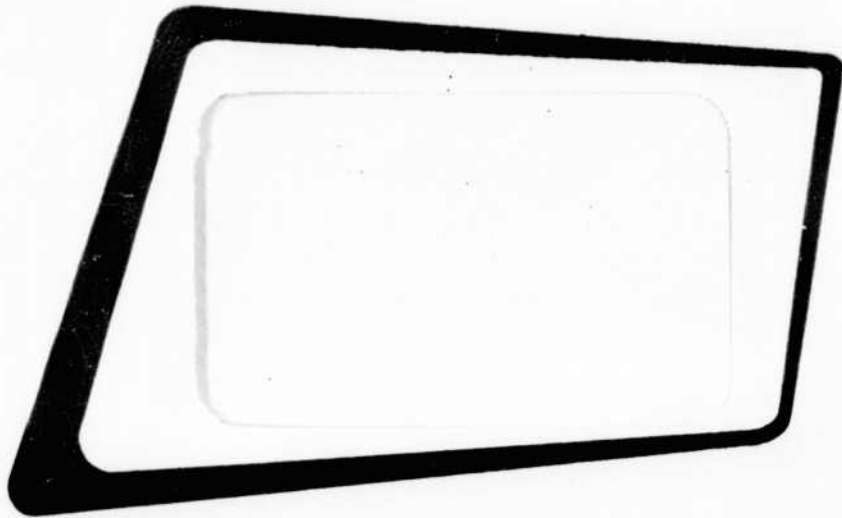

ALLEGANY BALLISTICS LABORATORY

Released to ASTIA by the
Bureau of
without restriction. NAVAL WEAPONS

ASTIA
RECEIVED
OCT 12 1962
TISIA

HERCULES POWDER COMPANY
Cumberland, Maryland

U. S. NAVY
Bureau of Naval Weapons
Contract NOrd 16640

ABL/Z-48

Minimizing Initiation Hazards
Through Proper Selection of
Materials of Fabrication (U)

July 1962

R. L. Keefe
E. A. Platt
R. H. Richardson

Paper presented at the 4th Annual Explosive Safety Seminar on High Energy
Solid Propellants, August 7-9, 1962, Langley Field, Virginia.

44
Copy No. —

TABLE OF CONTENTS

	<u>Page</u>
LIST OF FIGURES.....	v
LIST OF TABLES.....	vii
ABSTRACT.....	ix
INTRODUCTION.....	1
EXPERIMENTAL.....	3
RESULTS AND PHYSICAL CHARACTERISTICS.....	7
APPLICATIONS AND INFLUENCING FACTORS.....	11
GLOSSARY.....	21

LIST OF FIGURES

	<u>Page</u>
FIGURE 1	ABL Impact Sensitivity Testing Machine..... 4
FIGURE 2	ABL Sliding Friction Machine..... 5
FIGURE 3	Operating Principle of Impact and Friction Test Apparatus. 6
FIGURE 4	Horizontal Sigma Mixer..... 14
FIGURE 5	Casting Assembly..... 15
FIGURE 6	Mold Core Arrangement..... 16
FIGURE 7	Pressing Operation..... 17
FIGURE 8	Impact Threshold Initiation Level Vs. Polyethylene Anvil Thickness..... 18
FIGURE 9	Impact Threshold Initiation Level Vs. Weight of Impacting Mass..... 19
FIGURE 10	Schematic Drawing of Self-Positioning Teflon Vacuum Seal for High Speed Mixing..... 20

LIST OF TABLES

		<u>Page</u>
TABLE I	Typical Effect of Materials of Fabrication.....	8
TABLE II	Effect of Modulus of Compression and Hardness on Impact TIL	8
TABLE III	Effect of Coefficient of Friction on Friction TIL.....	9
TABLE IV	Effect of Surface Finish on Impact and Friction TIL...	9

ABSTRACT

The information obtained from the investigations conducted indicates that there are many factors to be considered in selecting the proper materials of fabrication for solid propellant processing facilities.

Selecting the proper materials of fabrication can reduce the impact and friction hazards significantly. The impact and friction tests, although limited in some aspects, are excellent tools for dividing materials into general classes of usefulness. Although studies of the factors influencing impact and friction results are not complete, it is apparent that the modulus of compression, hardness, and coefficient of friction are some of the major factors to be considered.

In the application of these materials, consideration must be given not only to the impact and friction results and such factors as modulus of compression and coefficient of friction, but also thermal and electrical conductivity, structural strength, load bearing characteristics and dimensional stability. In addition, complete analysis with testing under simulated conditions is required to insure that the expected improvement is realized and does not create an unforeseen hazard.

INTRODUCTION

With the advent of more sensitive ingredients, new processes and new materials of fabrication in the manufacture of rocket motors, it has become mandatory to seek various means of minimizing the possible hazards associated with the introduction of these advances. As one means of accomplishing this, a sensitivity investigation has been conducted which employs test components fabricated of both conventional and experimental materials of fabrication.

It would be well to define the term "materials of fabrication" in connection with its use in this presentation. We are concerned with those materials from which machinery, containers, tools, floors, etc., are made and which could present impact and friction surfaces in the processing areas. For the purpose of this discussion, consideration is not given to the materials employed in building walls, doors or barricades for air blast protection.

Materials selected for use in this study were those (1) most commonly used in the process, (2) possessing a lower modulus of compression or coefficient of friction or (3) contemplated for replacement parts or for use in new design. The situations considered and data generated by the above investigations are voluminous and sometimes of a specialized nature; therefore, only typical examples of the subject are presented.

The purpose of the investigation was threefold:

1. to find materials of fabrication for which an increased level of input energy is required to initiate combustibles, using impact and friction sensitivity results as the screening criteria.
2. to establish the limitations of a material's use by observation of its physical performance during the above tests and through consideration of its physical characteristics (i. e., structural properties, dimensional stability, thermal and electrical conductivity, hardness and coefficient of friction).
3. to use the above information in conjunction with an engineering analysis and, with simulated testing as required, for a specific application.

This report has several purposes: (1) to demonstrate the safety advantages of using specific materials of fabrication, (2) to examine the reasons for the observed effects of these materials on the initiation of combustibles, (3) to cite typical applications for such materials, and (4) to identify the factors which must be considered in their selection.

EXPERIMENTAL

The impact and friction data were obtained using the test apparatus shown in Figures 1 and 2. The operating principle of each device can be seen in Figure 3

Basically the impact apparatus is comprised of a falling weight which is used to impact a small amount of sample between two impacting components such as the hammer insert (nominally 0.2 in²) and anvil shown in Figure 3. Thus one can subject samples to varying degrees of impact energy by varying the drop height or weight.

In the friction apparatus, a given sample is placed on the sliding anvil and a force is applied to the sample by a stationary wheel (0.1 thick x 2" OD) attached to a hydraulic ram. A 26-pound pendulum is dropped from a selected height to strike the anvil with sufficient energy to slide the anvil perpendicular to the normal force at a nominal initial velocity of 8 ft/sec.

For this investigation and depending on the situation being studied, various materials were used in the hammer insert or stationary wheel and anvils. The friction apparatus also provided the kinetic coefficients of friction given herein.

The data obtained from both apparatus are given as the threshold initiation level (TIL). TIL is defined as the test level at which twenty consecutive trials result in "failures" (no initiation), with at least one "shot" (initiation) occurring at the next higher test level. The impact and friction threshold levels are given in terms of ft-lb/in² and lbs-force, respectively.

Hardness, modulus of compression and surface finish values were established by the following techniques: Rockwell and Durometer devices, hardness; ASTM-D-695-54, modulus of compression; and Brush Electronics Company "Surfindicator" instrument, surface finish.

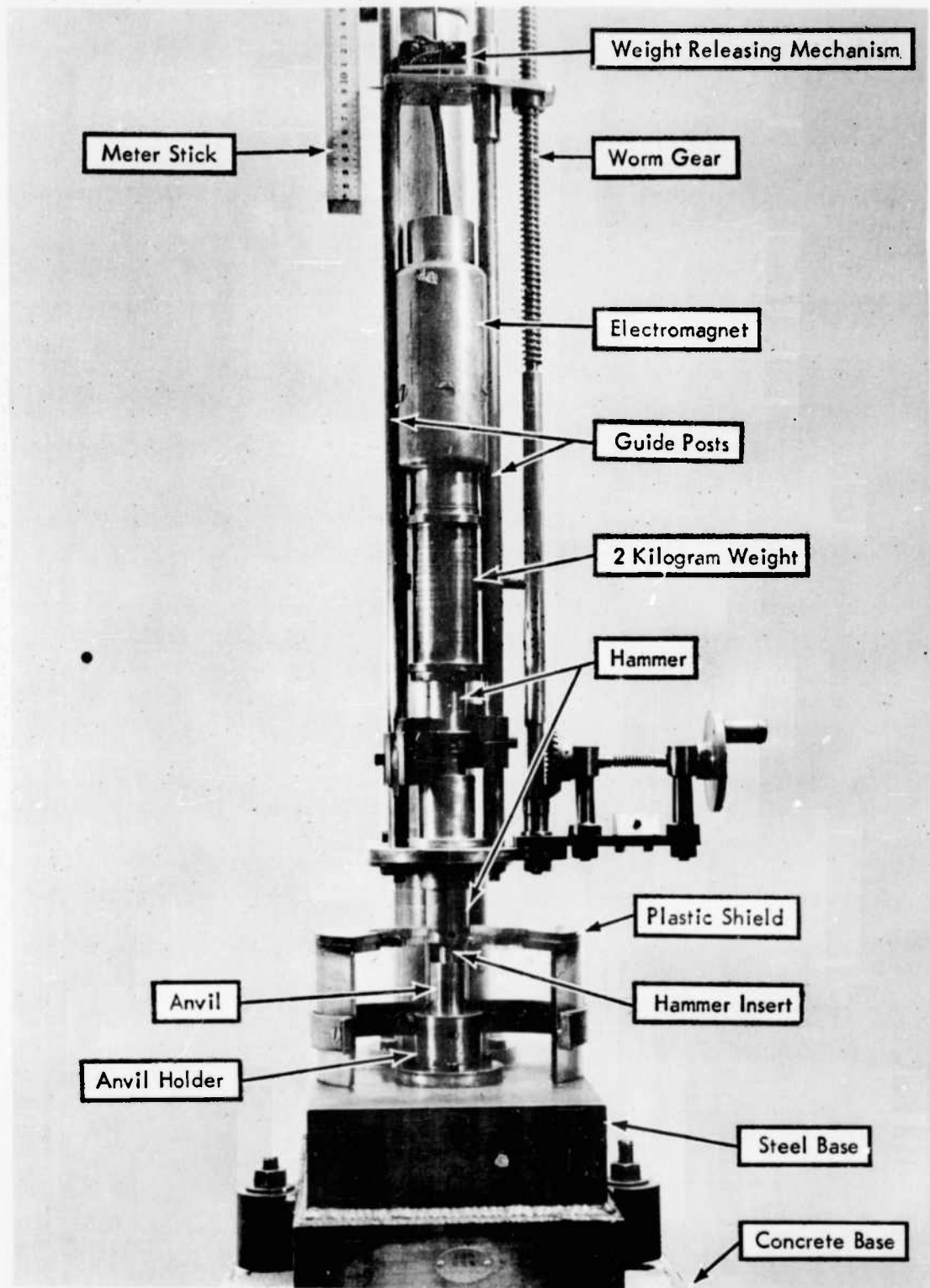

FIGURE 1

ABL Impact Sensitivity Testing Machine

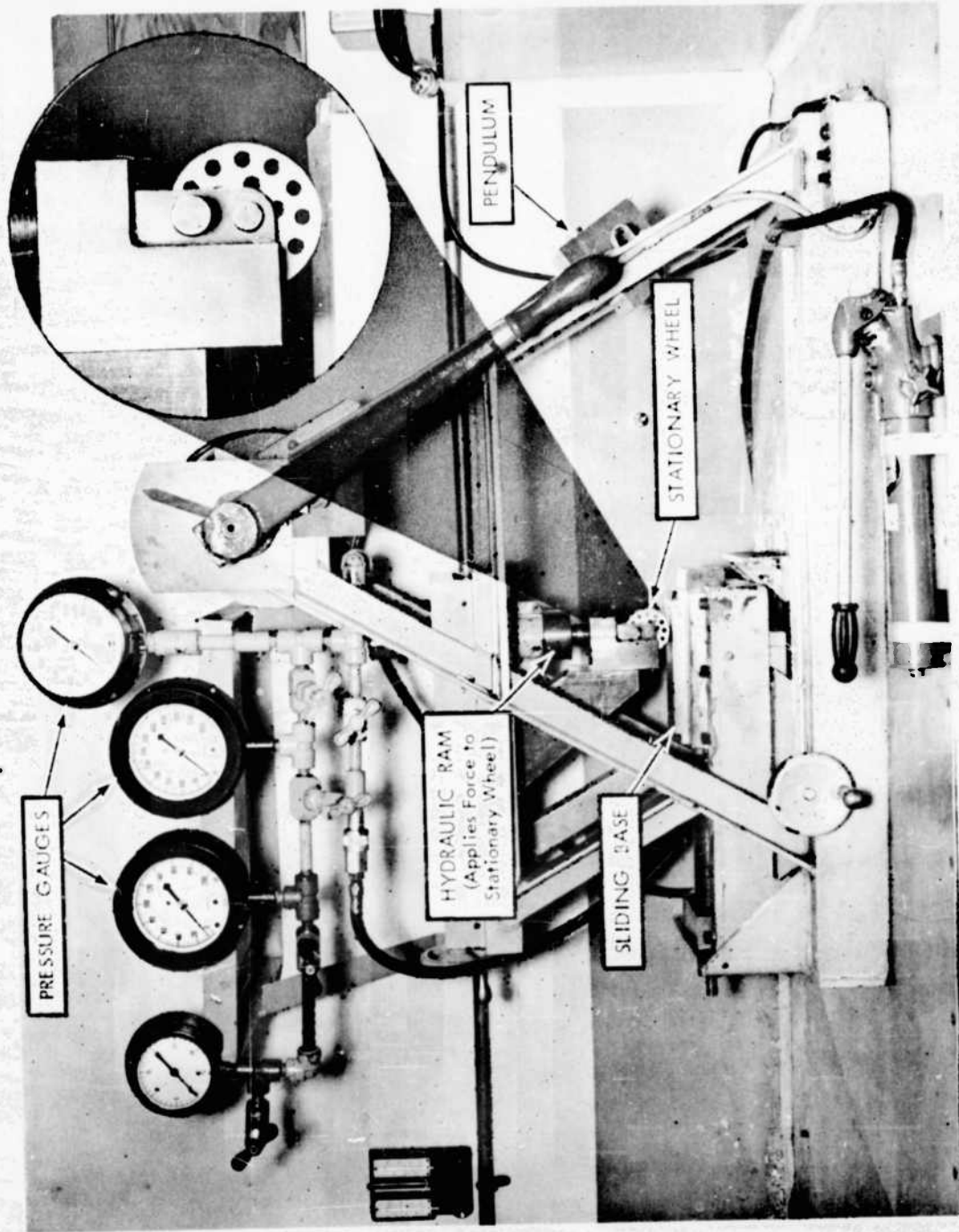
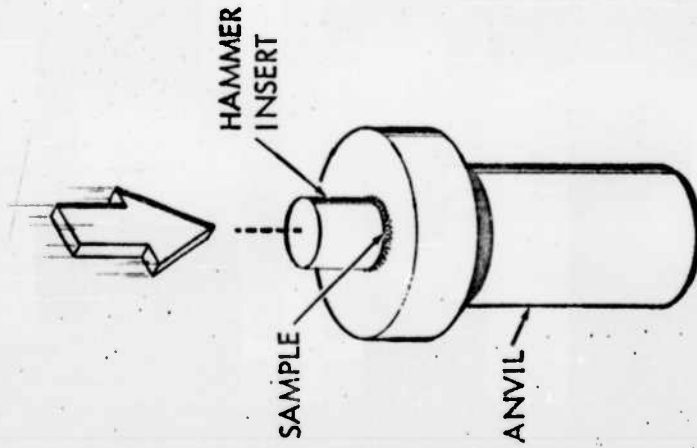

FIGURE 2
ABL Sliding Friction Machine

IMPACT
ENERGY



FRICTION
FORCE

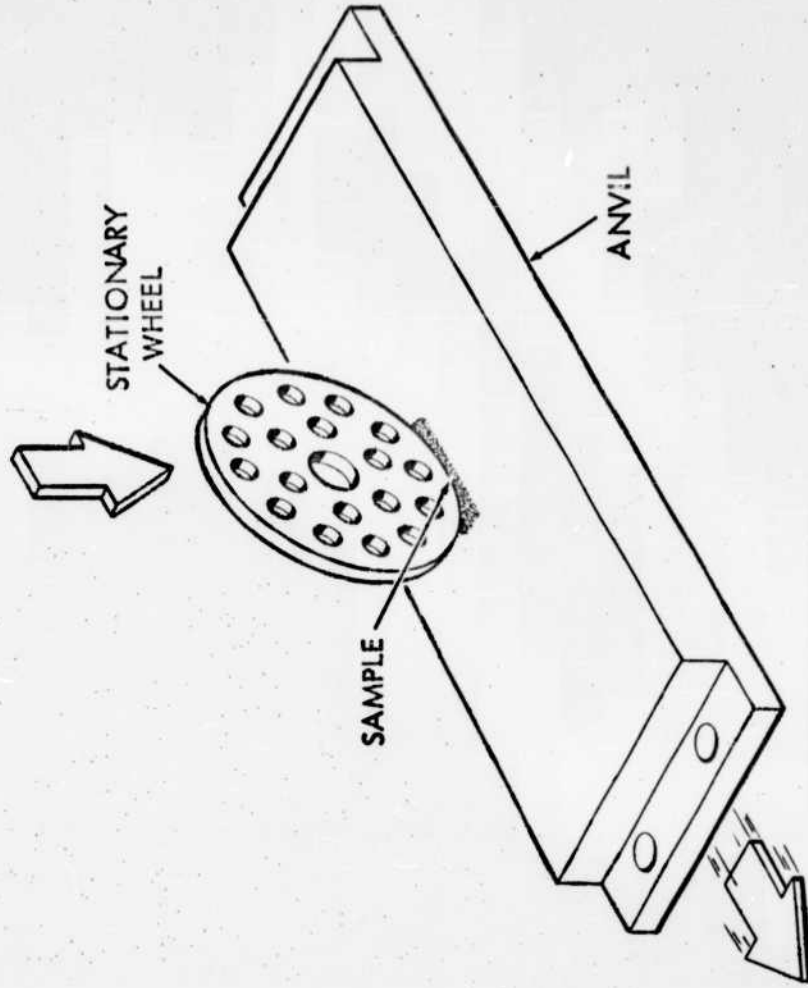

FIGURE 3
Operating Principle of Impact and Friction Test Apparatus

RESULTS AND PHYSICAL CHARACTERISTICS

Of the 43 combinations of materials tested thus far, seven combinations are shown in Table I for which impact and friction data are available using a single type of combustible. This table reveals two noteworthy items.

1. Significant increases in the level of input energy required for initiation can be achieved by proper selection of materials, e. g., SS/SS vs. SS/HI-fax. *
2. Not all materials significantly influence in the same direction both the impact and friction input energy required for initiation, e. g., SS/SS vs. TSS/TSS. * Small changes in input energy such as 2 to 6 ft-lbs/in² for SS/SS vs. SS/concrete are not considered significant as they are within the range of values that could be expected because of test variation.

The characteristics showing the most significant influence on impact data appear to be the ability of the material to compress readily and the hardness of the material. The gross effect can be seen in Table II by comparing SS/SS and wood/lead test data where the modulus of compression and relative hardness of both test components are either high or low. The modulus of compression is used here as an indication of the compression properties of a material. The substitution of one component with a low modulus of compression also increases TIL (see Table II), although generally less than when both components possess low moduli of compression.

Sufficient information is not available to afford a discussion of the interactions of the various factors influencing friction data previously shown in Table I. However, it would appear reasonable to assume that hardness and coefficient of friction are two important factors. Current information indicates that the coefficient of friction of materials of fabrication significantly influences TIL of solid and liquid combustibles (Table III). It is noteworthy that coefficient of friction determinations with combustibles between the components show that solids can act as a lubricant, reducing the coefficient of friction by as much as a factor of three, whereas no effect is apparent with liquids. This effect of solids on coefficient of friction is to be expected when the thin layer of solid has a lower shear strength than that of the test components.¹ This is further substantiated by the TSS/TSS data which show that this effect is nullified by the presence of a material having a lower shear strength than the combustible, such as, Teflon.

The effect of surface finish between the limits of 8 and 190 microinch on stainless steel was considered; and improvement was noted in the friction TIL with the smoother finishes (Table IV). Impact results are essentially unaffected by such variations of surface finish based on previous data on solids² and current data on NG. The force data for nitroglycerin are shown at 3 ft/sec to facilitate comparison.

* See Glossary

TABLE I
TYPICAL EFFECT OF MATERIALS OF FABRICATION

<u>Components</u> <u>Hammer or Wheel/Anvil</u>	<u>Nitroglycerin (TIL)</u>	
	<u>Impact</u> <u>(ft-lbs/in²)</u>	<u>Friction</u> <u>(lbs-force)</u>
SS/SS*	2.0	< 1
SS/Concrete	6.0	< 1
TSS/TSS	4.0	≥ 900
SS/A1	3.0	≥ 100
SS/Lead	13.0	≥ 150
A1/Wood	45.0	≥ 150
SS/Hi-fax	60.0	≥ 360

* See Glossary for meaning of abbreviations

TABLE II
EFFECT OF MODULUS OF COMPRESSION AND HARDNESS ON
IMPACT TIL

<u>Type of Component</u> <u>Hammer/ Anvil</u>	<u>Modulus of</u> <u>Compression</u> <u>psi x 10⁴</u> <u>Hammer/Anvil</u>	<u>Relative</u> ✓ <u>Hardness</u>	<u>Nitroglycerin (TIL)</u> <u>(ft-lbs/in²)</u>
SS/SS	8700/8700	Hard/Hard	2.0
SS/Lead	8700/27	Hard/Soft	13.0
PE/SS	2/8700	Soft/Hard	25.0
Wood/Lead	82/27	Soft/Soft	≥ 85

✓ Hard - Rockwell "B" - 80 through "C" - 60.

Medium - Rockwell "H" - 10 through "B" - 79.

Soft - < Rockwell "H" - 10.

TABLE III
EFFECT OF COEFFICIENT OF FRICTION ON FRICTION TIL

<u>Components Wheel/Anvil</u>	<u>Kinetic Coefficient of Friction Without Sample</u>	<u>Combustible Sample</u>	<u>Kinetic Coefficient of Friction With Sample</u>	<u>Friction Sensitivity Threshold Initiation Level (lbs-force)</u>
SS/SS	0.48	Nitroglycerin	0.47	< 1 160
		CMDB Propellant*	0.14	
TSS/TSS	0.05	Nitroglycerin	0.05	> 900 840
		CMDB Propellant	0.05	

* CMDB propellant was tested in a ground state resulting in a particle size approximating 0:025 x 0:025.

TABLE IV
EFFECT OF SURFACE FINISH ON IMPACT AND FRICTION TIL

<u>Surface Finish (microinch)</u>	<u>Impact (ft-lbs/in²) Nitroglycerin</u>	<u>Friction (lbs-force)</u>	
		<u>Nitroglycerin</u>	<u>CMDB Propellant</u>
Rough (190 microinch)	4	4 at 3 ft/sec.	< 1 at 8 ft/sec
Medium (60 microinch)	2	20 at 3 ft/sec	160 at 8 ft/sec
Smooth (8 microinch)	4	> 60 at 3 ft/sec	280 at 8 ft/sec

APPLICATIONS AND INFLUENCING FACTORS

The ultimate purpose of this work is to aid in the selection of materials of fabrication which will increase safety in the propellant manufacturing process. This requires that each application be considered on its own merit and, more importantly, that the selection of a material to reduce sensitivity in one area does not introduce a new hazard by increased sensitivity in another area. To explore all sensitivity areas requires consideration of factors such as thermal and electrical conductivity, structural strength, load bearing characteristics and dimensional stability as well as the effect on impact and friction input energy.

For the purpose of this discussion, polyethylene (generally Hi-fax) and Teflon will be used as examples since they typify materials which can be employed to improve impact and friction hazards and yet are unique for specific applications.

In general they are employed as seals, gaskets, mats, bumpers, linings, scrapers, coatings, containers, guards, collars, nozzles and coresets. Some specific applications are as follows:

1. Submerged Teflon glands in mixers (Figure 4) - Replacement of a metal seal with one made of Teflon results in a significant contribution to the safety of the mixing operation, particularly when oxidizers such as ammonium perchlorate are used. The use of Teflon provides a low coefficient of friction and a compressible, soft material should undue force be applied through excessive shaft deflection.
2. Hi-fax inserts (Figure 5) - The purpose of the insert is to eliminate metal to metal contact between the mold core and associated parts during transportation and core removal. Hi-fax inserts were used in this particular application because the integrity of Teflon coatings or similar types of thin coatings could not be relied upon under conditions of high localized forces and because, as pointed out earlier, such coatings do not provide any significant impact advantage. The use of Hi-fax inserts is relatively inexpensive as compared to some other materials, particularly coatings, which require frequent rework. The above application is an example of the use of a compressible, soft material with a low coefficient of friction where complete substitution of the material was not desirable for reasons of structural strength and dimensional stability.
3. Hi-fax fin cores (Figure 6) - Hi-fax was best suited as material for fin cores because its physical form and its placement in the mold provided good dimensional tolerance, and because Hi-fax was structurally acceptable, economical, and reduced the potential impact and friction hazards during mold handling and fin removal.
4. Hi-fax gaskets and bumpers (Figure 7) - Hi-fax was employed in a hydraulic press to provide a cushioning effect for the reduction of impact hazards and to eliminate metal to metal contact.

The foregoing has discussed some specific applications of Teflon and polyethylene (Hi-fax) demonstrating their varied advantages. Some limitations in the use of these materials are shown by the following examples:

1. Polyethylene as a material of fabrication to minimize impact hazards - Because polyethylene is a relatively soft, compressible material, it is generally conceded to be useful for applications where some means is required to absorb some or all of the impact which might occur in propellant processing. A factor to be considered in selecting the proper thickness of material is the mass of the impacting object. This can be demonstrated by referring to Figure 8 which shows the increase in impact TIL as a function of increasing thickness of polyethylene for a constant mass drop weight (2.2 lbs.). This figure also shows that representative solid and liquid combustibles react differently to varying thickness. Figure 9 shows that the effect of thickness is dependent to varying degrees on the mass of the drop weight. The nitroglycerin data indicate that the use of compressible materials under process conditions of heavy impacting masses may not improve the impact hazard significantly. The solid combustible (CMDDB propellant) data indicate there may be a critical effective thickness (>0.03 <0.09 inch) of polyethylene insofar as the impacting mass is concerned.

Thus, when consideration is given to the use of polyethylene or any similar material to reduce impact hazards, the thickness must be established as a function of the impacting mass. Representative combustibles in the form of test samples may be employed as guides. However, in the final analysis the specific combustible must be considered.

2. The use of Teflon as a material of fabrication for a vacuum seal in high speed mixing (200-500 rpm) (Figure 10) - The principle of the design was to allow lateral displacement of the mixer shaft and still provide a vacuum seal. Teflon was selected on the basis of its low coefficient of friction.

Analysis of this application revealed that under conditions of absolute vacuum the seal could be subjected to a vertical 64 lbs. force and that this force could be delivered over as small an area as 0.1 in^2 . Since it was reasonable to assume that this area, as well as the ball and socket joint, could become contaminated with combustibles, impact, friction and simulated operational tests were performed. The more pertinent results were as follows:

- (a) It was found that Teflon was not structurally adequate as the bearing plate under the forces involved.
- (b) Teflon could gall in the ball and socket joint because of high temperatures generated at normal mixer speeds (400 rpm). Temperature measurements showed that Teflon apparently reached its heat distortion temperature which is given in

Reference 3 as 266°F.

- (c) Initiation of combustibles was likely even at speeds lower than those contemplated for normal operation (400 rpm).
- (d) Initiation was the result of both the frictional energy created and the gross temperature increase resulting from the heat generated by the Teflon components. It is noteworthy that the friction test does not consider the latter condition, and prior analysis of the situation; based on friction results alone, did not predict initiation for many of the combustibles tested.
- (e) The use of air as a coolant and vacuum grease to reduce the frictional and heat generation hazards was inadequate.
- (f) Although Teflon is an excellent dielectric material, no electrostatic charges were detected under the conditions of its intended use.

In the vacuum seal application Teflon has several limitations. It was structurally inadequate, its thermal conductivity was too low, and its very good coefficient of friction was overshadowed by other considerations.

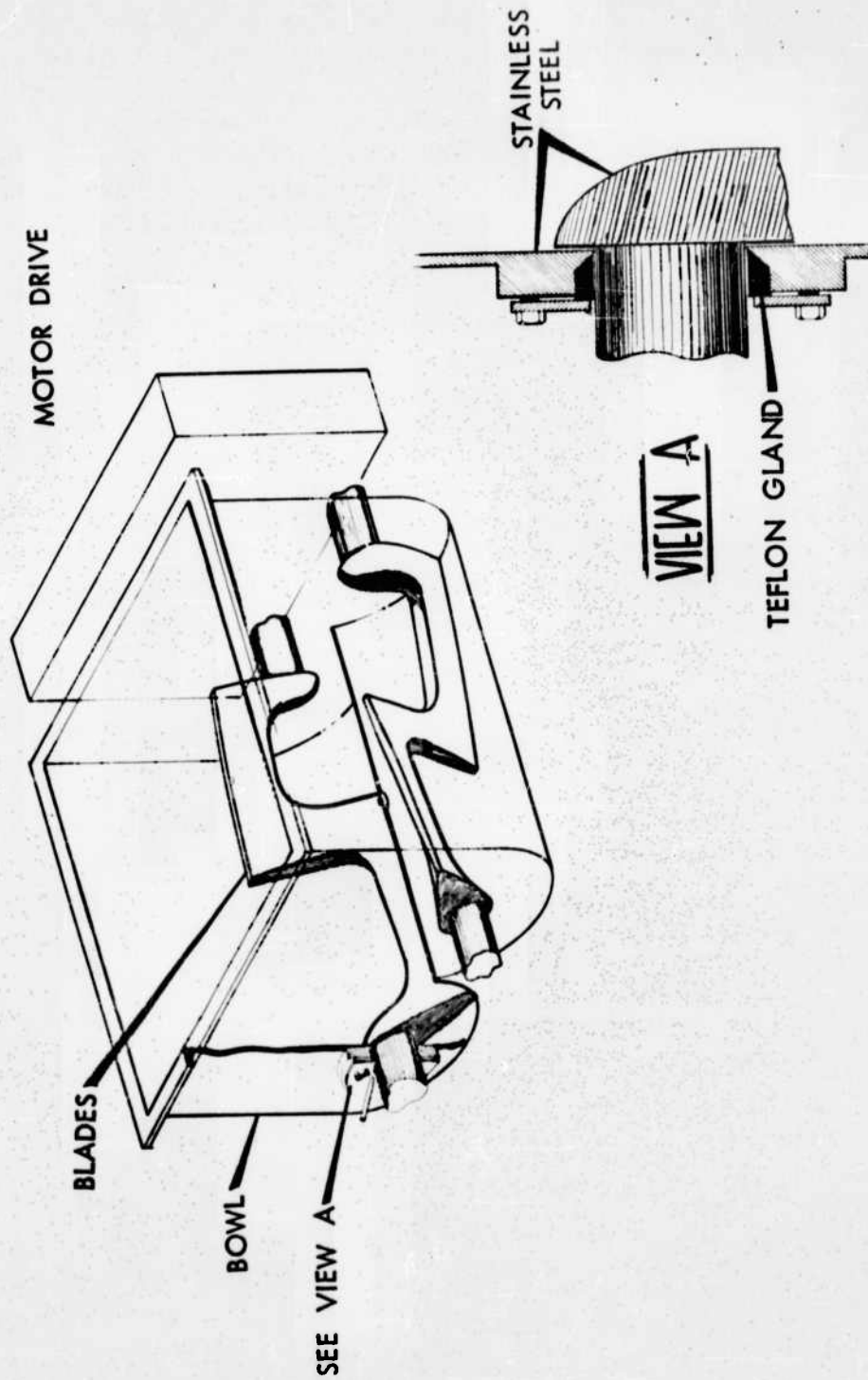

FIGURE 4
Horizontal Sigma Mixer

0818

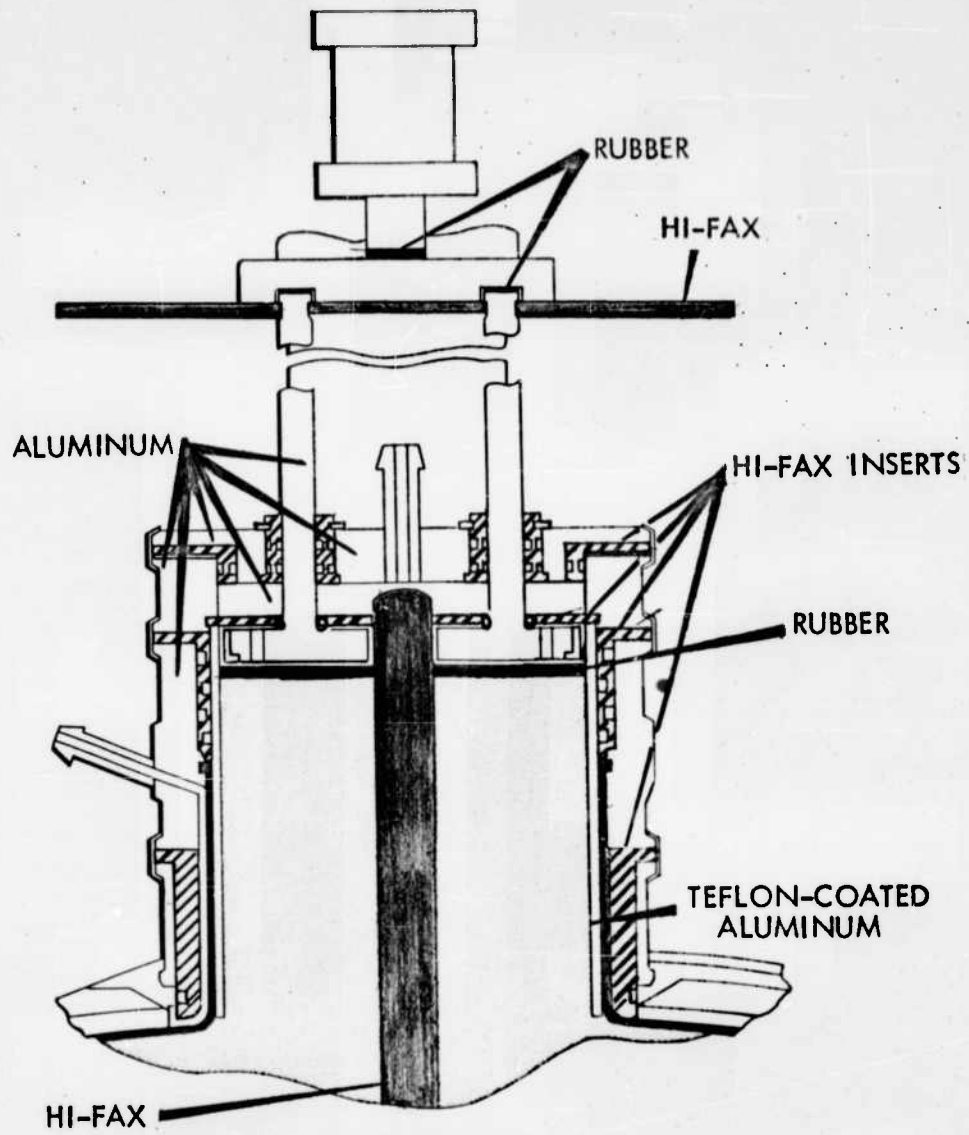

FIGURE 5
Casting Assembly

0819

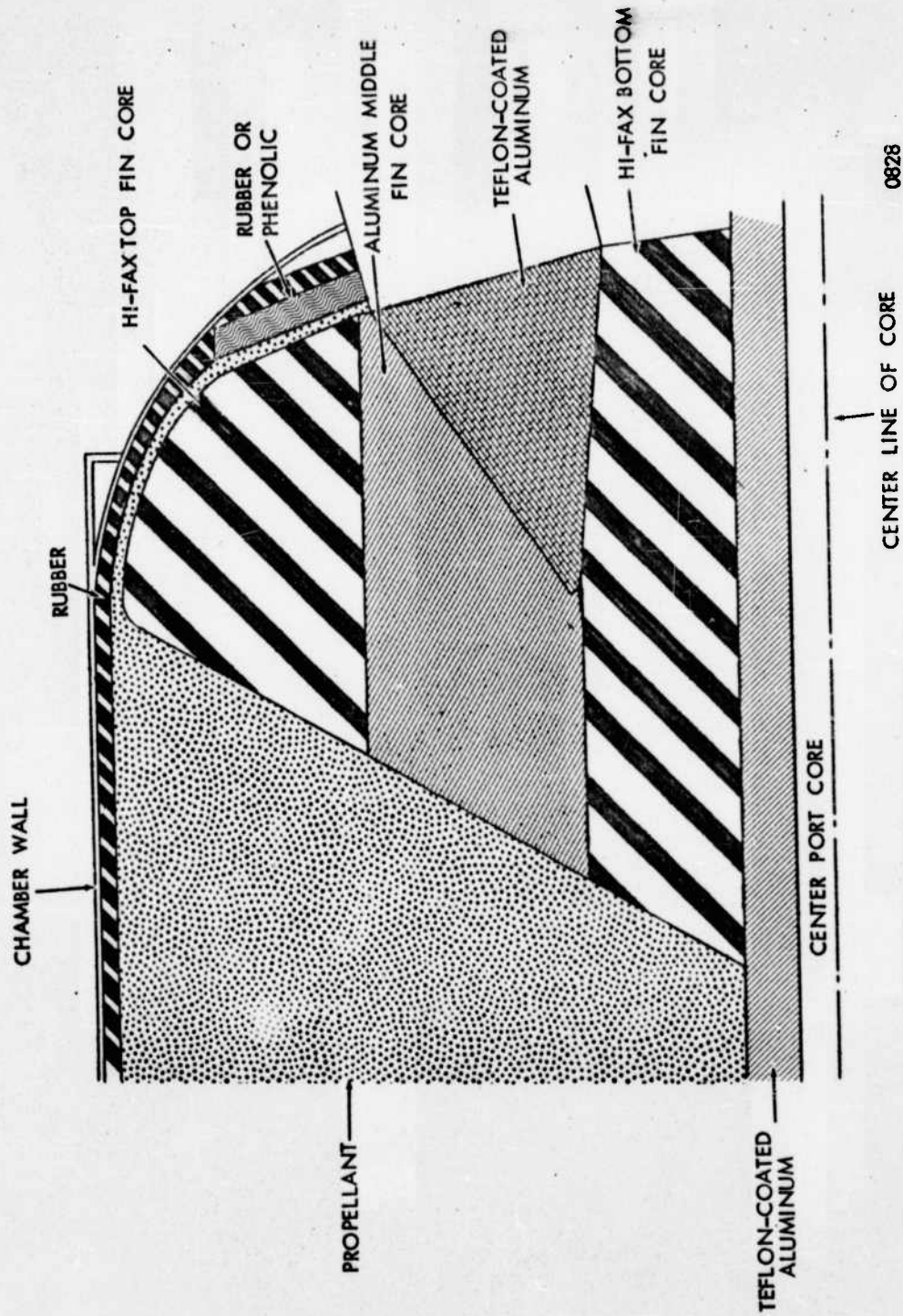

FIGURE 6
Mold Core Arrangement

0828

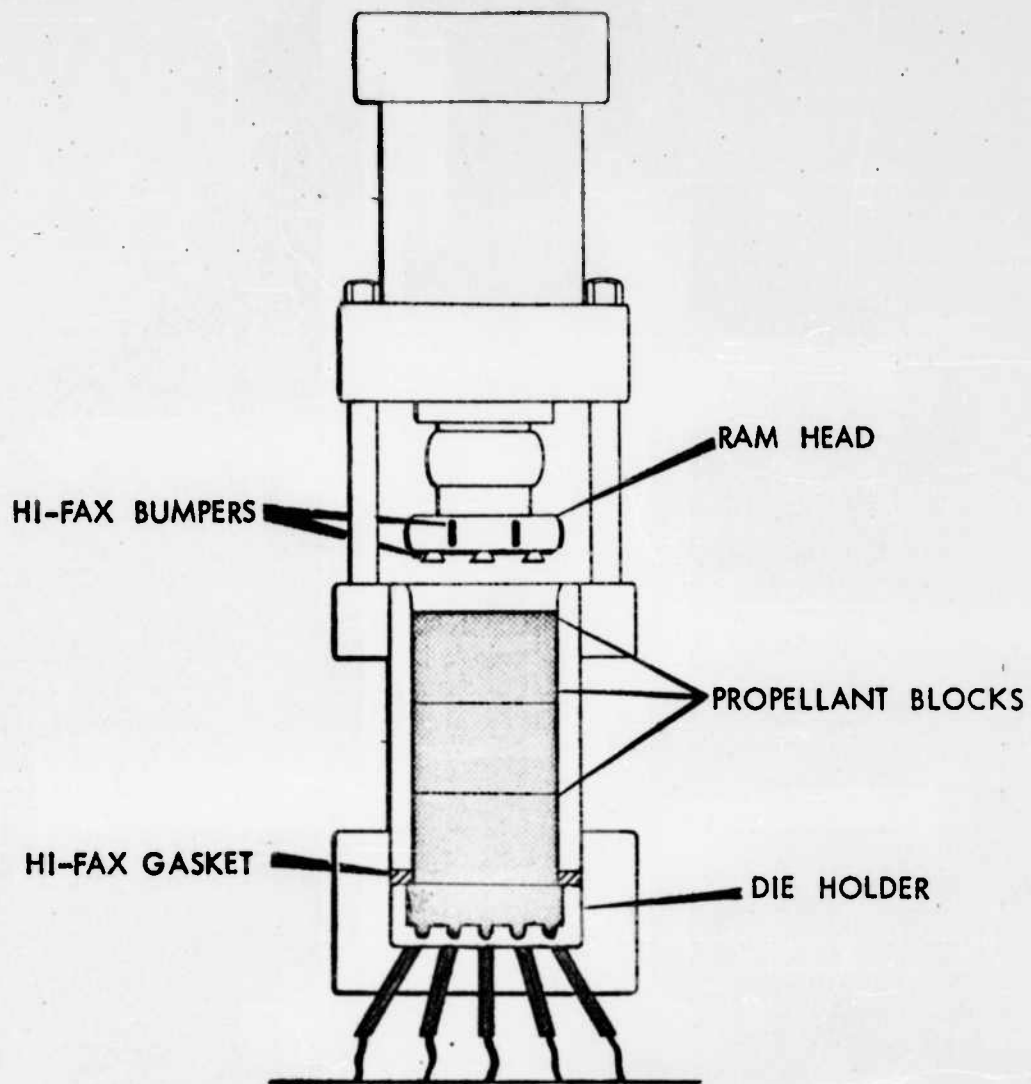
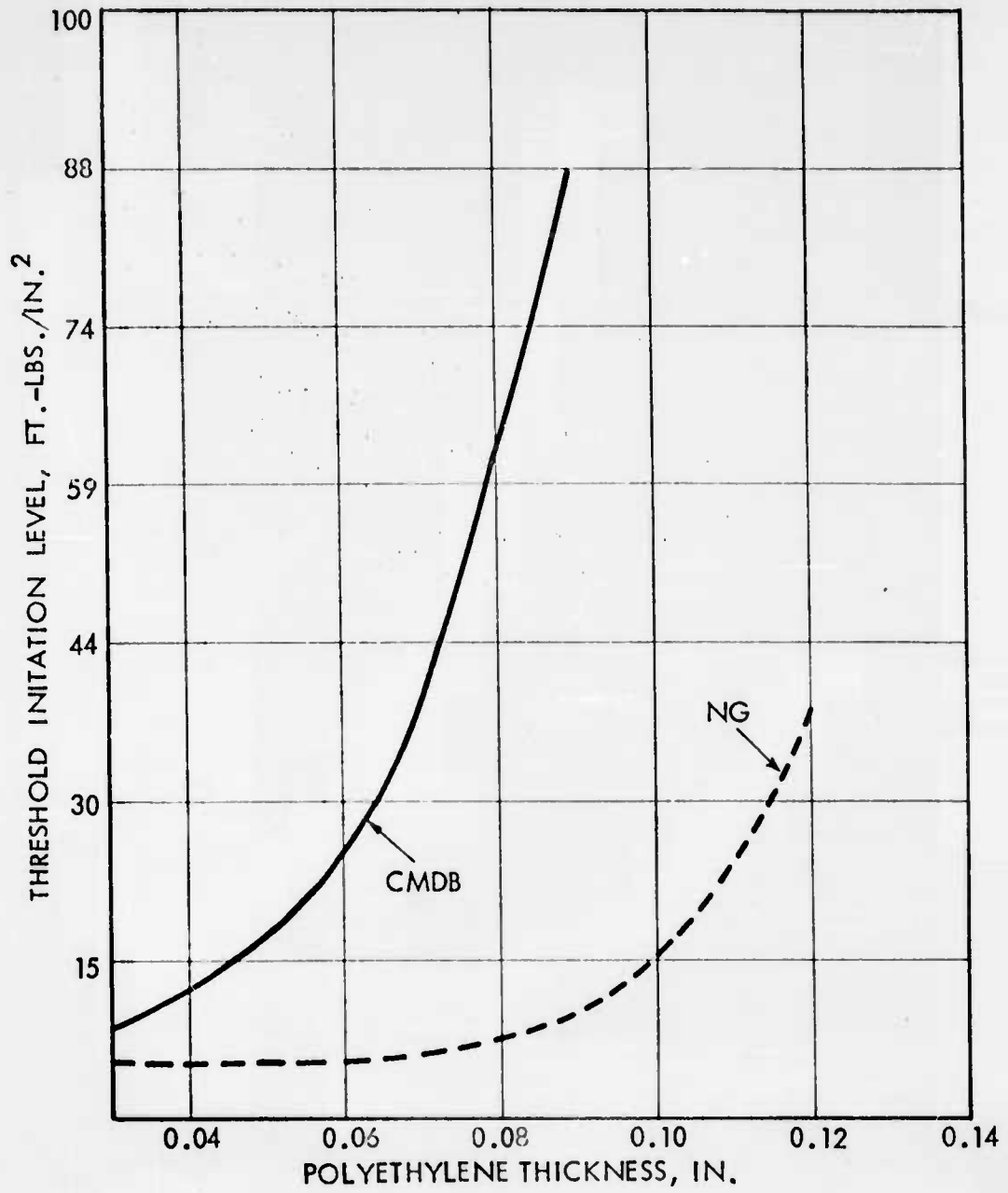

FIGURE 7
Pressing Operation

0817



0830

FIGURE 8
Impact Threshold Initiation Level Vs. Polyethylene Anvil Thickness

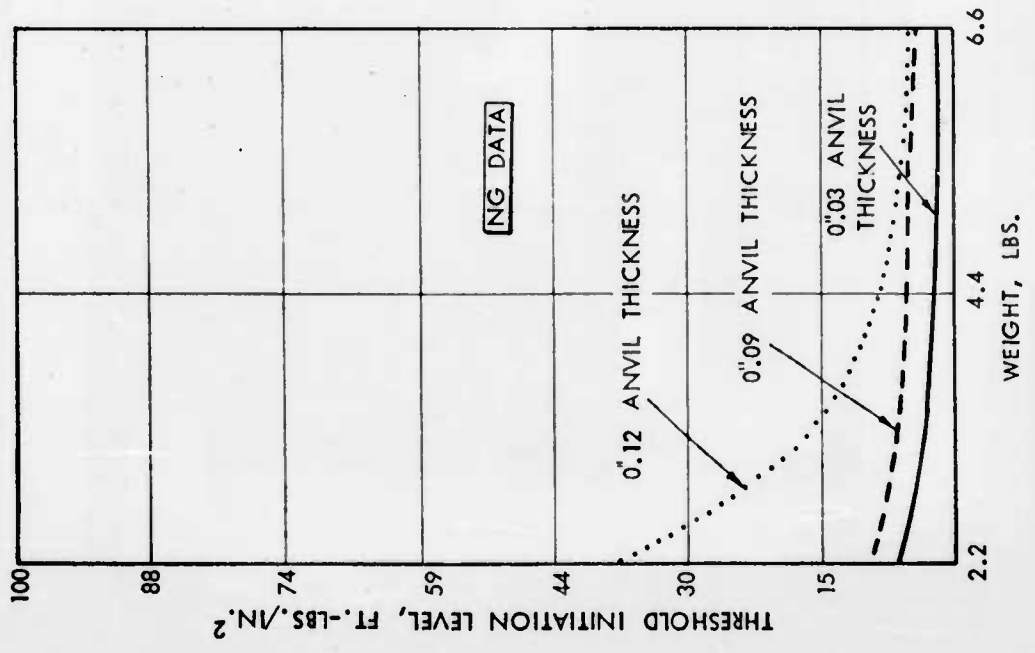
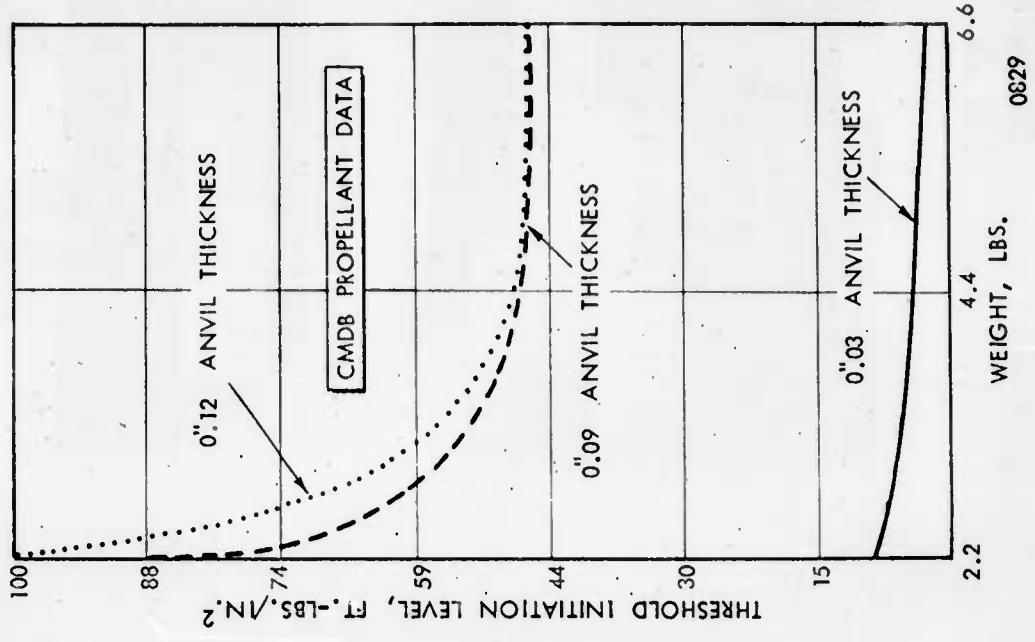

FIGURE 9 Impact Threshold Initiation Level Vs. Weight of Impacting Mass

0829

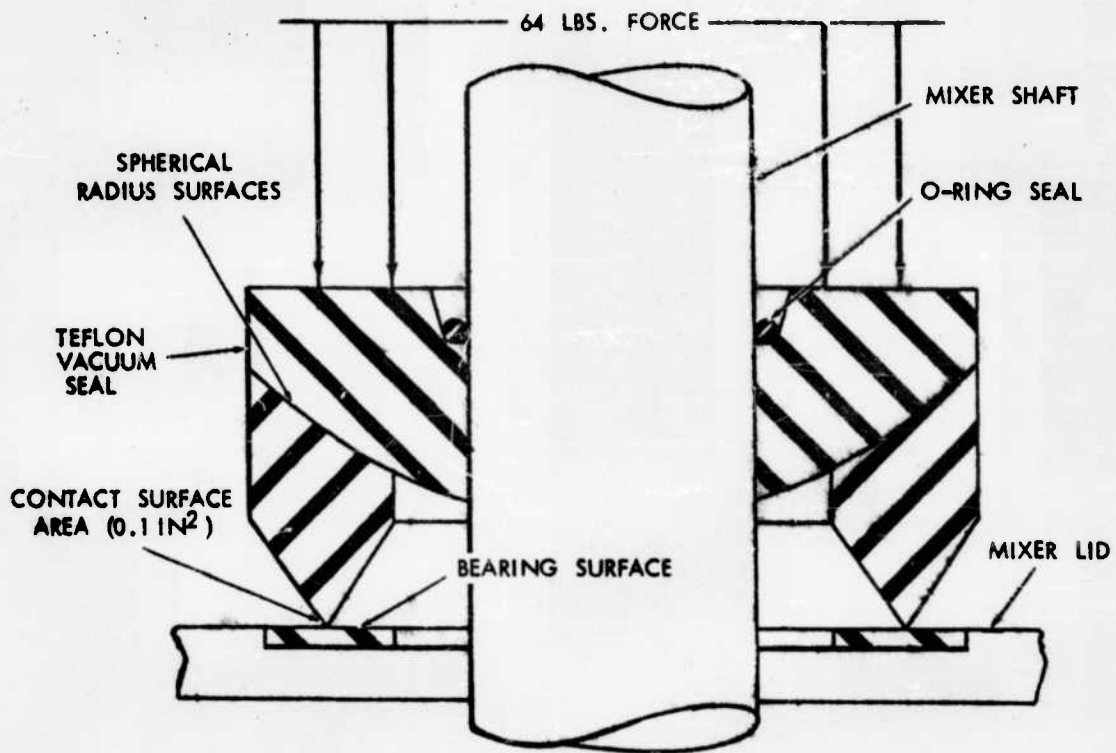

FIGURE 10 0814
Schematic Drawing of Self-Positioning Teflon Vacuum Seal for High Speed Mixing

GLOSSARY

ABL	Allegany Ballistics Laboratory
Al	Aluminum
CMDB Propellant	Composite Modified Double-Base Propellant
Hi-fax	Hercules Powder Company trade name for densified polyethylene
NG	Nitroglycerin
PE	Polyethylene
SS	Stainless Steel
Teflon	E. I. duPont de Nemours & Company trade name for tetrafluoroethylene
TSS	Teflon-coated stainless steel, nominally 0.001 inch thick
TIL	Threshold initiation level
∞	The symbol means that initiation of the test sample was not obtained in twenty trials (1) at the highest level on the impact apparatus and (2) the highest level on the friction apparatus that would consistently allow the slider to move the standard one inch or that at greater forces would damage the wheels and/or anvils.

REFERENCES

1. F. P. Bowden, and D. Tabor, The Friction and Lubrication of Solids, Oxford University Press, New York, 1954, Chapter V.
2. R. H. Richardson, "Hazards Evaluation of the Cast Double-Base Manufacturing Process," - Allegany Ballistics Laboratory Report X-47 (U), December 1960.
3. N. A. Lange, Handbook of Chemistry, McGraw-Hill Book Company, New York, 1961, p. 849.

DISTRIBUTION LIST

Bureau of Naval Weapons
Washington 25, D. C.
Attn: RMMP-2
Attn: DLI-30

Director, Special Projects
Washington 25, D. C.
Attn: SP-271

Hercules Research Center
Technical Information Division
Wilmington 99, Delaware

Hercules Powder Company
Kenvil, New Jersey
Attn: Library

Hercules Powder Company
Bacchus Works
Magna, Utah
Attn: Library

Hercules Powder Company
Radford, Virginia
Attn: Mr. E. H. Carroll

Mr. E. J. Klecka
ABL Technical Representative
Naval Propellant Plant
Indian Head, Maryland

U. S. Naval Propellant Plant
Indian Head, Maryland
Attn: Library

National Aeronautics & Space Administration
Washington 25, D. C.
Attn: Office of Tech. Information and
Educational Programs, Code ETL

Picatinny Arsenal
Dover, New Jersey
Attn: Library

White Sands Missile Range
New Mexico
Attn: ORDBS-OM-TL

Ordnance Ammunition Command
Joliet, Illinois
Attn: ORDLY-AREL, Eng. Library

Diamond Ordnance Fuze Laboratories
Washington 25, D. C.
Attn: ORDTL(012)

U. S. Naval Ordnance Laboratory
White Oak, Silver Spring
Maryland
Attn: Library

U. S. Naval Ordnance Test Station
China Lake, California
Attn: Tech. Library Branch

U. S. Naval Research Laboratory
Washington 20, D. C.
Attn: Chem. Div. Code 6130, Mr. R. R. Miller

Jet Propulsion Laboratory
Pasadena 3, California
Attn: Mr. I. E. Newlan

Solid Propellant Information Agency
Silver Spring, Maryland

Space Technology Laboratories
Los Angeles 45, California
Attn: Tech. Information Center

Armed Services Explosives Safety Board
Washington 25, D. C.
Attn: B. J. Mast

TR Armed Services Tech. Information Agency
Arlington Hall Station
Arlington 12, Virginia

FOREIGN ADDRESSEES

Imperial Chemical Industries, Ltd.
Stevenston, Ayrshire, Scotland
Attn: Mr. E. Whitworth

Imperial Chemical Industries, Ltd.
Kidderminster,
Worcestershire, England
Attn: Dr. G. P. Sillitto