

UNCLASSIFIED

AD 286 096

*Reproduced
by the*

**ARMED SERVICES TECHNICAL INFORMATION AGENCY
ARLINGTON HALL STATION
ARLINGTON 12, VIRGINIA**



UNCLASSIFIED

NOTICE: When government or other drawings, specifications or other data are used for any purpose other than in connection with a definitely related government procurement operation, the U. S. Government thereby incurs no responsibility, nor any obligation whatsoever; and the fact that the Government may have formulated, furnished, or in any way supplied the said drawings, specifications, or other data is not to be regarded by implication or otherwise as in any manner licensing the holder or any other person or corporation, or conveying any rights or permission to manufacture, use or sell any patented invention that may in any way be related thereto.

286 096

63-1-2

286 096

AMC TR 7-652(IV)

AMC INTERIM REPORT 7-652(IV)

ENGINEERING AND PRODUCTIZATION OF AN INTEGRATED
FAMILY OF BACKWARD WAVE OSCILLATORS

James E. Orr
and
Benjamin V. Valles

LITTON ELECTRON TUBE CORPORATION

Contract: AF33(600)43396

Interim Technical Engineering Report
7 April 1962 - 7 July 1962

A family of electronically tuned, broadband oscillator tubes has been developed that are physically and electrically similar from band to band. These tubes are being production engineered and productized for system application.

ASTIA
JUL 22 1962
RECEIVED
TISA

RESEARCH AND DEVELOPMENT BRANCH
MANUFACTURING METHODS DIVISION

AMC Aeronautical Systems Center
United States Air Force
Wright-Patterson Air Force Base, Ohio

ABSTRACT - SUMMARY
Interim Technical Progress Report

AMC INTERIM REPORT 7-652(IV)
September 1962

ENGINEERING AND PRODUCTIZATION OF AN INTEGRATED
FAMILY OF BACKWARD WAVE OSCILLATORS

James E. Orr
and
Benjamin V. Valles
Litton Electron Tube Corporation

Analysis of Band 1, 6 and 8 tubes which have completed life tests are given. This analysis includes design changes which have been incorporated in the tubes to improve life performance. Band 1 manufacturing changes are described which result in a tube with better transient frequency behavior and improved operation in high temperature environments. Also, twelve items of general manufacturing improvement which apply to all bands are described.

TABLE OF CONTENTS

| | <u>Page</u> |
|--------------------------------------|-------------|
| Abstract - Summary | i |
| Title Page | ii |
| Notices | iii |
| Forward | iv |
| Objectives of Contract | 1 |
| Schedule | 3 |
| Life Test Analysis | 4 |
| Band 1 Manufacturing Improvements | 7 |
| General Manufacturing Improvements | 9 |
| 1. Tube Packaging | 9 |
| 2. Magnetic Shunt | 11 |
| 3. Exhaust Tubulation | 12 |
| 4. Sized Top End Plate | 13 |
| 5. Sized Body Ring | 13 |
| 6. Weighed Welding Stand | 13 |
| 7. Electrical Input Insulation | 14 |
| 8. Crown Alignment | 14 |
| 9. Finger Brazing Jig | 15 |
| 10. Ramp Profile Milling | 15 |
| 11. Automatic Finger Cutting Machine | 16 |
| 12. Hobbed Horn and Ramp | 16 |
| Program for next Quarter | 17 |

LIST OF FIGURES

1. Relationship of Sole Shield to Surrounding Parts
2. Relationship of Heater to Cathode Inner-Sleeve
3. L-3721 Hollow Sole Construction
4. Original Design for Packaging
5. Tube Clamp Sleeve Assembly
6. Modified Design for Packaging
7. Intermediate Stages of Packaging
8. Final Fittings Jig
9. Initial Assembly Stage
10. Second Assembly Stage
11. Third Assembly Stage
12. Exhaust Tubulation
13. Welding Fixture
14. Electrical Input Insulation
15. Crown Stacking Jigs and Crowns
16. Finger Brazing Jig and Crown
17. Contour Milling Machine
18. Automatic Finger Cutting Machine
19. Copper Forming Punch

AMC TR 7-652 (IV)

AMC INTERIM REPORT 7-652 (IV)

ENGINEERING AND PRODUCTIZATION OF AN INTEGRATED
FAMILY OF BACKWARD WAVE OSCILLATORS

James E. Orr
and
Benjamin V. Valles

LITTON ELECTRON TUBE CORPORATION

Contract: AF33(600)43396

Interim Technical Engineering Report
7 April 1962 - 7 July 1962

A family of electronically tuned, broad band oscillator tubes has been developed that are physically and electrically similar from band to band. These tubes are being production engineered and productized for system application.

RESEARCH AND DEVELOPMENT BRANCH
MANUFACTURING METHODS DIVISION

AMC Aeronautical Systems Center
United States Air Force
Wright-Patterson Air Force Base, Ohio

NOTICES

When Government drawings, specifications, or other data are used for any purpose other than in connection with a definitely related Government procurement operation, the United States Government thereby incurs no responsibility nor any obligation whatsoever; and the fact that the Government may have formulated, furnished, or in any way supplied the said drawings, specifications, or other data, is not to be regarded by implication or otherwise as in any manner licensing the holder or any other person or corporation, or conveying any rights or permission to manufacture, use, or sell any patented invention that may in any way be related thereto.

Copies of AMC Technical Reports should not be returned to the AMC Aeronautical Systems Center unless return is required by security considerations, contractual obligations, or notice on a specific document.

Qualified requesters may obtain copies of this report from ASTIA, Document Service Center, Arlington Hall Station, Arlington 12, Virginia.

FORWARD

This Interim Technical Engineering Report covers all work performed under contract AF33(600)43396 from 7 April 1962 to 7 July 1962.

This contract with Litton Electron Tube Corporation, San Carlos, California, is administered under the direction of Melvin D. Brown, Ralph B. Brinkman, Arnold H. March and others of the Manufacturing Methods Division, AMC, Aeronautical Systems Division, Wright-Patterson Air Force Base, Ohio.

The primary objective of the Air Force Manufacturing Methods Program is to increase producibility, and improve the quality and efficiency of fabrication of aircraft, missiles, and components thereof. This report is being disseminated in order that methods and/or equipment developed may be used throughout industry, thereby reducing costs and giving "MORE AIR FORCE PER DOLLAR".

Your comments are solicited on the potential utilization of the information contained herein as applied to your present or future production programs. Suggestions concerning additional Manufacturing Methods development required on this or other subjects will be appreciated.

A. Objectives of Contract

The purpose of this contract is to conduct an engineering study of a family of M-type backward wave oscillators. Phase I of this study shall be directed toward redesigning and productizing this tube type to the extent necessary to build quantities at a high yield. Phase II shall be directed toward production fabricating a minimum of six tubes of each type with the same design and construction and subjecting these tubes to all environmental and life tests required by the finalized specification data.

The tubes in the family will have the following characteristics:

| Band | Tube Type | | Minimum Output Power | RF Output Structure |
|------|-----------|-------------------------------|----------------------|---------------------|
| 1 | L-3721A | 1000-1200 Mc 1200-1400 Mc | 200 Watts | 7/8" Coax |
| 2 | L-3722 | 1400-1575 Mc 1575-1800 Mc | 200 Watts | 7/8" Coax |
| 3 | L-3723 | 1800-2175 Mc 2175-2550 Mc | 200 Watts | 7/8" Coax |
| 4 | L-3724A | 2500-3025 Mc 3025-3550 Mc | 180 Watts | 7/8" Coax |
| 5 | L-3725A | 3500-4175 Mc 4175-4850 Mc | 180 Watts | 7/8" Coax |
| 6 | L-3726A | 4800-5675 Mc 5675-6550 Mc | 165 Watts | DR-19 |
| 7 | L-3727A | 6500-7525 Mc 7525-8550 Mc | 150 Watts | DR-19 |
| 8 | L-3728A | 8500-9750 Mc 9750-11000 Mc | 150 Watts | DR-19 |

Two frequency ranges are available within each tube due to the recent advances in wide band sole tuning. Litton will not develop band 2 and 3 at the present time.

B. Schedule

Official authorization was granted to proceed with Phase II for bands 1, 6 and 8 on April 10, 1962. However, unofficial life tests had been running on a band 8 tube as early as January 18, 1962 and on a band 6 tube on February 9, 1962 and a band 1 tube on February 7, 1962. Official authorization was granted to proceed with Phase II for bands 5 and 7 on July 2, 1962. A band 5 tube started running life test on July 5, 1962.

All tubes which have completed 1000 hours operating time or failed prematurely are opened and carefully analyzed. In the next section, concerning life test analysis, the few samples that have completed life tests during this quarter are discussed.

C. Life Test Analysis

The following table summarizes the life test results on the first three tubes which completed life test.

| <u>Band</u> | <u>Date Started</u> | <u>Date Finished</u> | <u>No. Hours</u> | <u>Status</u> |
|-------------|---------------------|----------------------|------------------|--------------------------|
| 1 | 2/7/62 | 5/15/62 | 1059.1 | OK |
| 6 | 2/9/62 | 3/19/62 | 701.6 | Failed with heater short |
| 8 | 1/18/62 | 4/25/62 | 1095.0 | OK |

Band 1

This tube started life tests with a beam current of 325 mA. Since this tube is capable of two current level operation (325 mA or 500 mA) it was not clear which level was to be used for life test. The decision to operate all band 1 tubes on life test at 500 mA was clarified at an AF coordination meeting held at Wright Field during the quarter. After 419.1 hours at 325 mA the beam current was changed to 500 mA and tube operated at this level until it had accumulated 1059.1 hours.

An inspection of the inside of the tube revealed several areas where vaporized copper had lodged on insulators. The largest accumulation appeared on sole insulators opposite the collector electrode and also opposite delay line fingers near the rf output of the tube. A metal shield attached to the sole electrode was designed and incorporated into future tubes which prevented "line of sight" vapor from lodging on the sole insulators. Figure 1 shows the relationship of this shield to other parts of the tube.

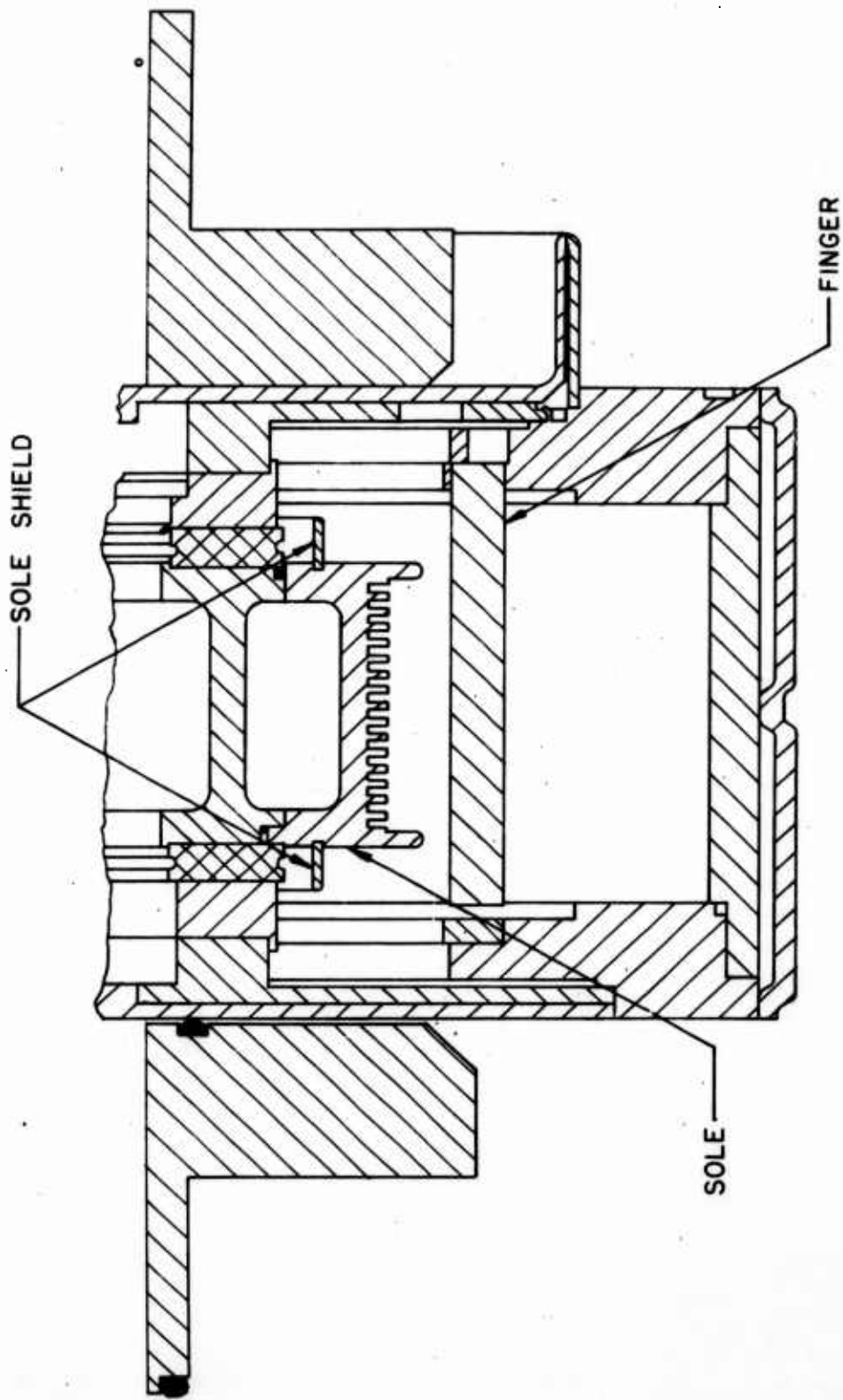

RELATIONSHIP OF SOLE SHIELD TO SURROUNDING PARTS

FIGURE-1

Band 6

Failure to finish 1000 hours on this tube was due to a shorted heater. Inspection of the heater coil revealed the fact that the coil had a slight axial taper. The various heater assembly procedures were inspected and it was found that the mandrel used to form the coil inadvertently had the undesirable taper. A new mandrel was ordered to replace the one which was out of tolerance. The reason that the heater coil shorted can be attributed to a reduction in heat transfer where the taper prevented several turns from seating firmly against the cathode inner sleeve. These turns therefore operated at high temperatures where recrystallization of the tungsten wire coupled with the cycled operation ultimately led to the failure. The reduction in diameter of the outside diameter of the heater coil due to the taper was only .002"; however, this fit between heater coil and inner sleeve must be tight due to the elevated temperatures of the operating heater coil. Figure 2 shows the relationship of the heater coil to the inner sleeve.

Band 8

This tube operated satisfactorily without noticeable change in characteristics until 911.0 hours. At this time the accelerator current changed from 0.0 mA to -0.1 mA. Then at 1095.0 hours accelerator current changed to +0.1 mA. A careful inspection of the accelerator region revealed that the surface of the accelerator blade opposite the cathode had an unusually high deposit of cathode material. This deposit could account for the negative current.

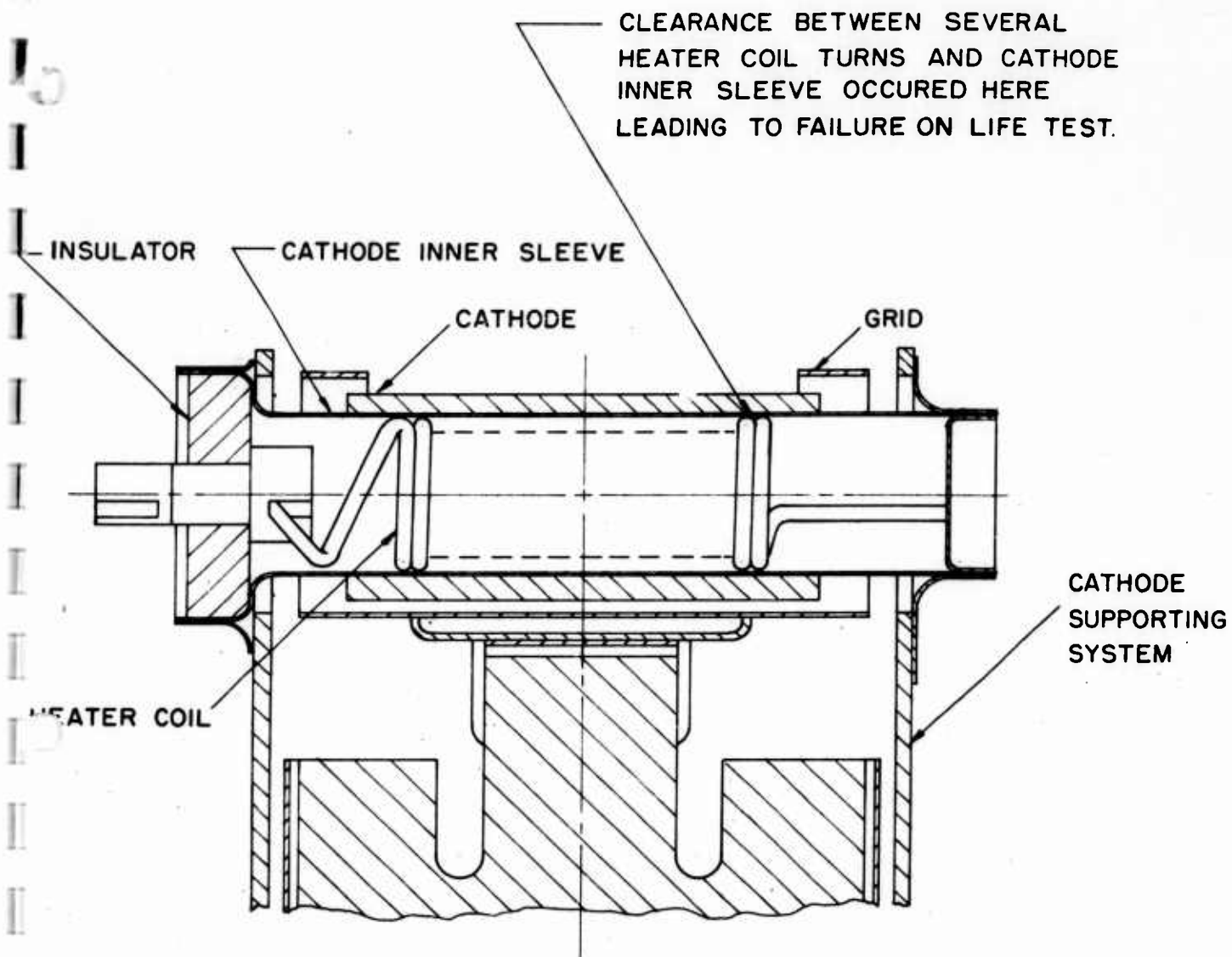

RELATIONSHIP OF HEATER TO CATHODE INNER SLEEVE

FIGURE - 2

This problem can best be controlled by making sure cathode temperature is not higher than necessary.

D. Band 1 Manufacturing Improvements

One of the most important developments during this quarter was the demonstration of a better yield regarding power output. For several months we have been having difficulty meeting the power density requirements at 500 mA beam current. The power density was about 5% low at the extreme high end of the low range when full sole modulation was employed. However, under the CW tuning mode the power output was well above specification throughout the bands. During the quarter the percentage of tubes that make power output for all modes of operation has been exceedingly good so that we are now concentrating on other aspects of the design. The improvements resulted from better understanding of the electron optics, control of permanent magnet quality and familiarization of hot test optimization procedures gained with experience.

Some tubes have been rejected due to arcing when the input oil temperature reached 100°C while the tubes were operating CW at the maximum power input. The seriousness of this problem of arcing appears to be somewhat dependent on the power supply that is used. During an arc to ground the sole current will go positive. If the supply is not capable of supplying this current the sole voltage will become unstable, thus aggravating the condition. Several improvements in the tube were initiated which have greatly alleviated the problem and are listed below:

1. More Efficient Cooling.

A. Cooling jacket was redesigned to wrap around the outside of the tube. This jacket replaced the two tubular pipes formerly used.

(1) Dies to form the jacket were built and parts were fabricated on May 25.

2. Elimination of Gas Sources.

A. Changes have been made in the crown to eliminate gas pockets near the alloy grooves.

B. The attenuator was redesigned so that outgassing procedures were simplified.

C. All cupron and moly parts used are vacuum fired. Previously some parts were only hydrogen fired.

D. Fingers are being vac-fired.

E. Lossy ceramic parts are being stored in vacuum containers and only vac-fired in small quantities prior to use.

F. Exhaust schedule has been lengthened.

In addition to the above changes, an improvement in transient frequency change was made by utilizing a hollow sole structure in place of the usual solid copper structure. Sole expansion or contraction due to thermal effects causes a first order change in frequency. The new sole structure reduced the mass of the sole considerably, thereby decreasing the time for thermal stabilization. Figure 3 is a sketch showing the construction of the new sole structure. The three parts (1) outer ring (2) inner ring and (3) platform are brazed together forming the hollow structure.

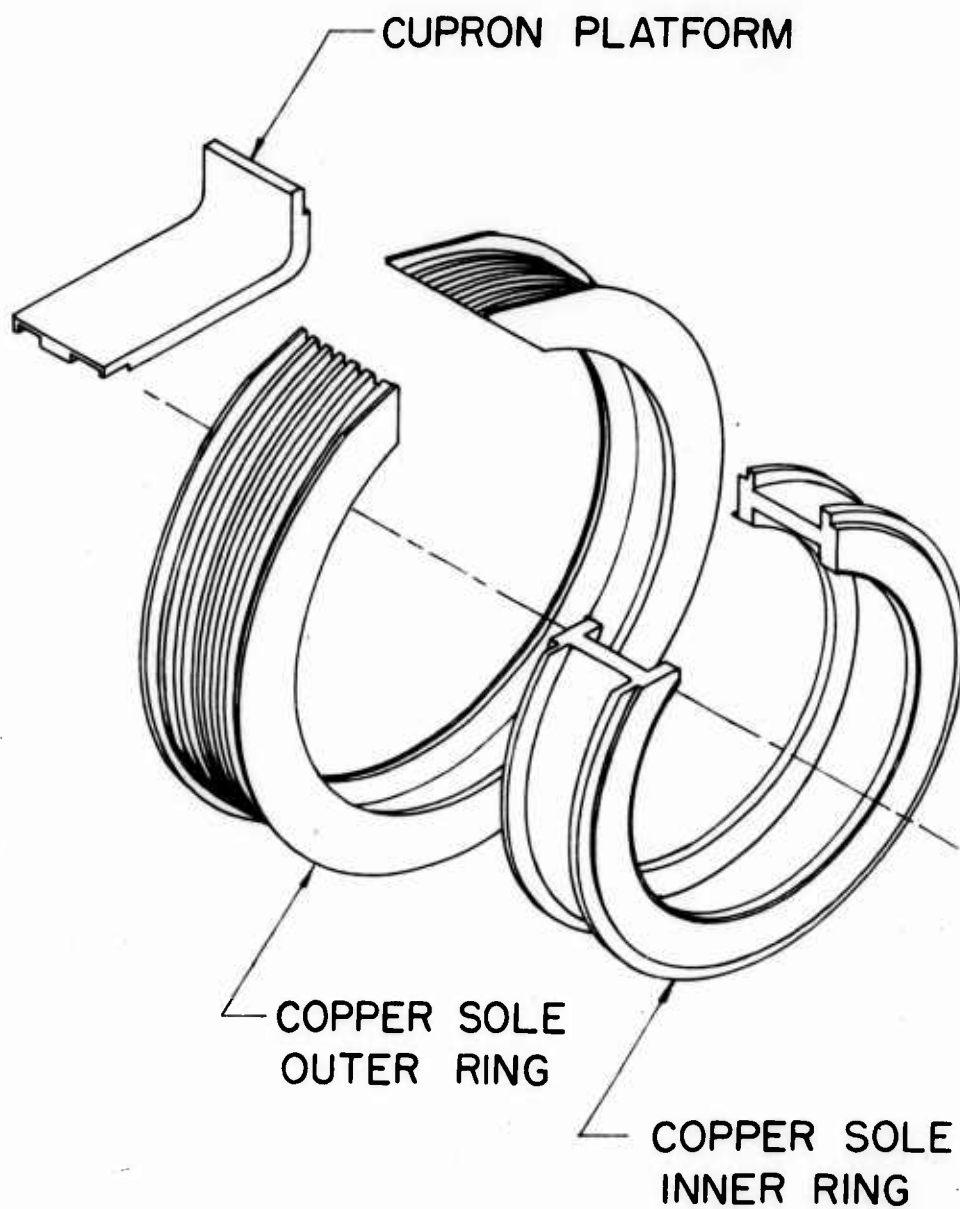

L-3721 HOLLOW SOLE CONSTRUCTION

FIGURE- 3

E. General Manufacturing Improvements

Item 1 Tube Packaging

An evaluation of the packaging design for the L-3720 family of tubes in bands 6 to 8 revealed some disadvantages in assembly that had to be eliminated. Figure 4 shows a cross-sectional drawing of the original tube packaging design. The tube is held between the two magnet halves under pressure by an elastic "o" ring at point "A". In turn the magnets and mounting base "B" together with the cover plate and magnetic shunts at "C" are held together by a stainless steel sleeve "D" which is flared under pressure at both ends. This is a very simple and inexpensive way of holding the tube and its associated external fittings together and still meet mechanical and outline dimension requirements.

The main disadvantage is that two final tests for the tube are required after the mounting base is put on.

This additional handling increased the losses due to mechanical rejections (scratches, nicks, etc.). Also no re-adjustment of the pole pieces was possible if they were inadvertently moved during the handling of the tube. If the tube is rejected due to mechanical, hydraulic or electrical failure and the tube required remagnetizing or reworking of any sort, the stainless steel sleeves have to be machined out. This machining operation is an expensive and difficult operation and defeated our effort to salvage and rework parts and assemblies. The mounting base as an example is a precision machined piece of aluminum with many close tolerance dimensions. The unit cost per part is \$20.00 and losses of any sort affected the cost of the tube appreciably. A better design was clearly necessary

1

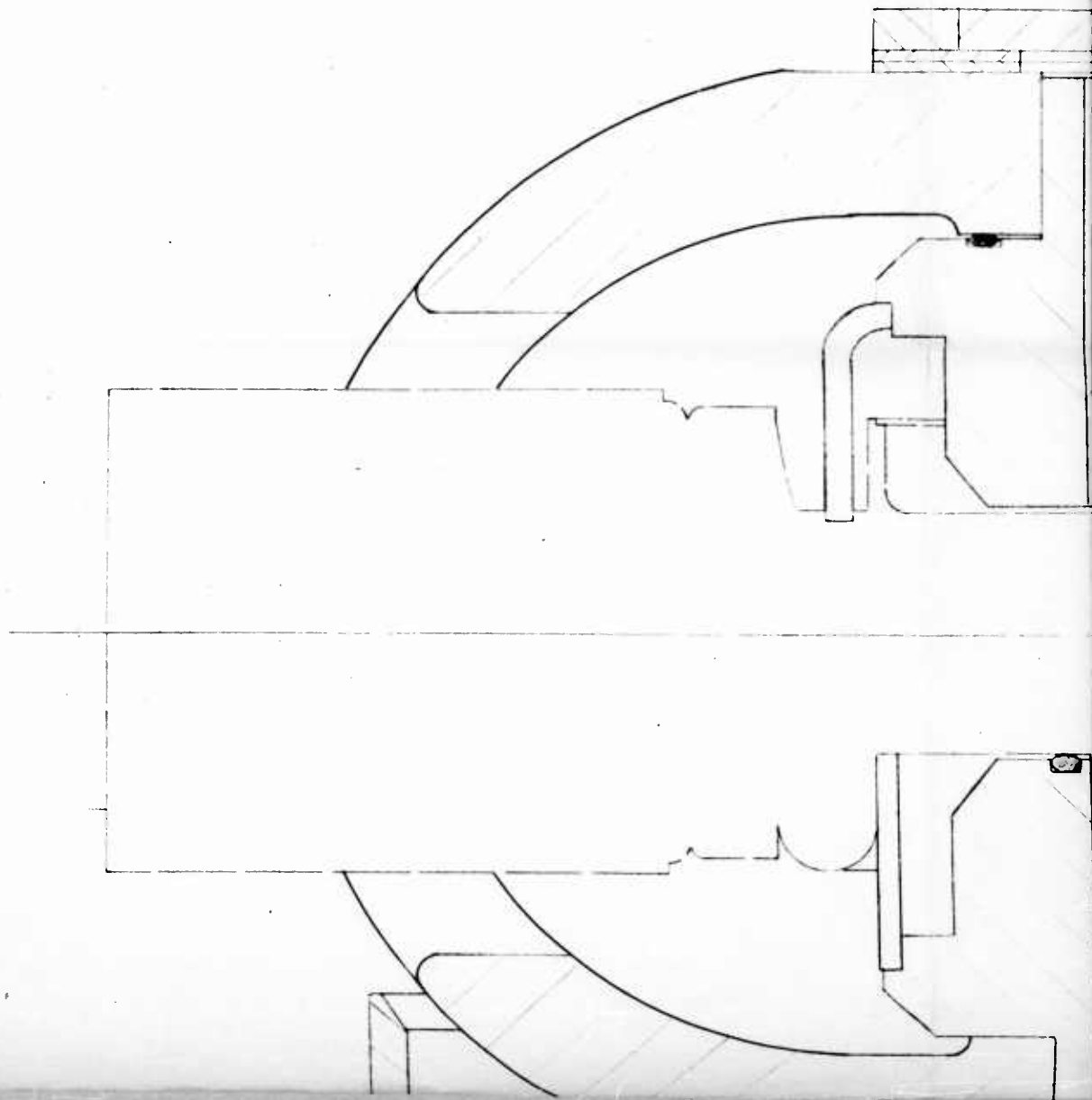

2

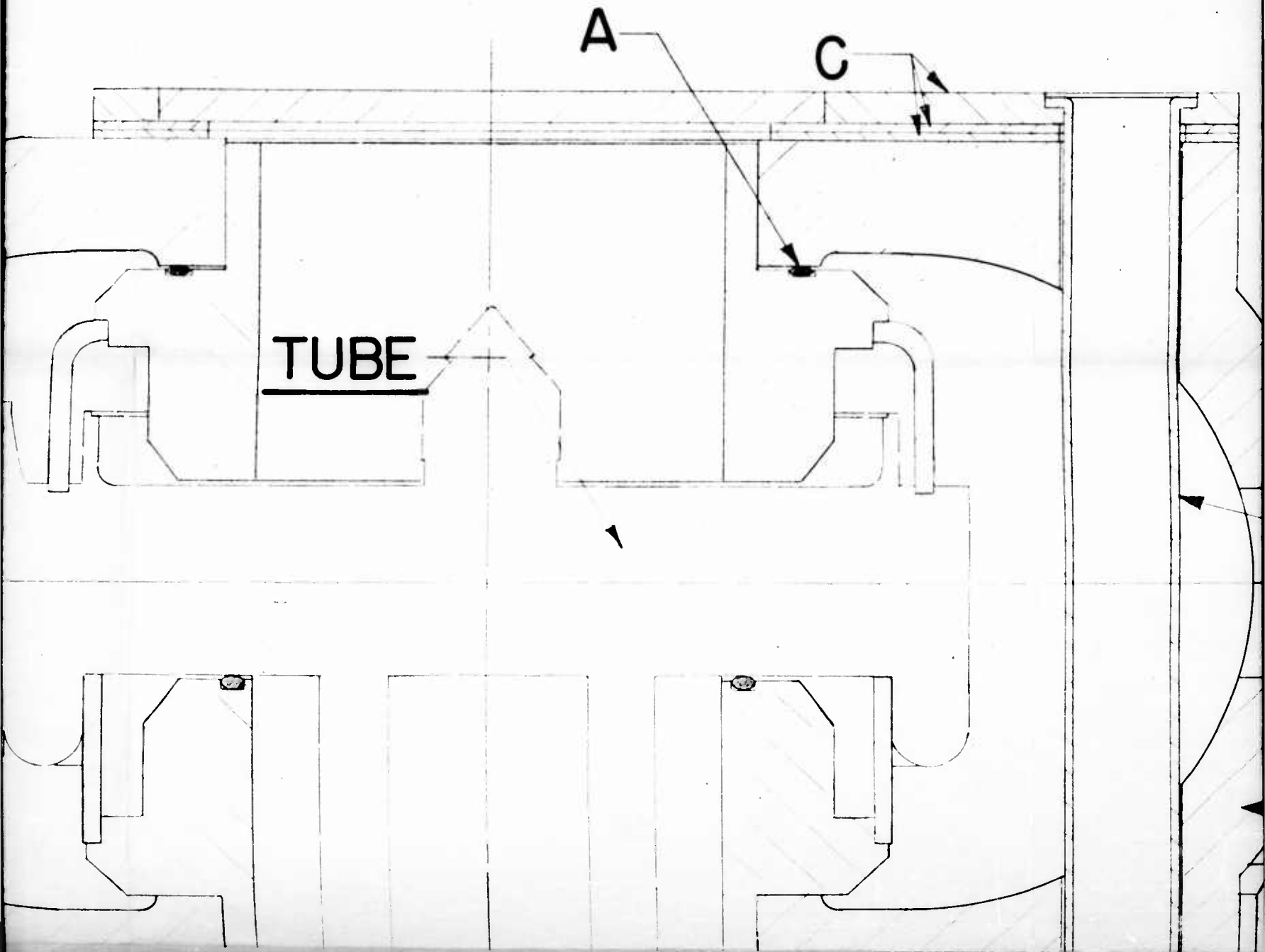

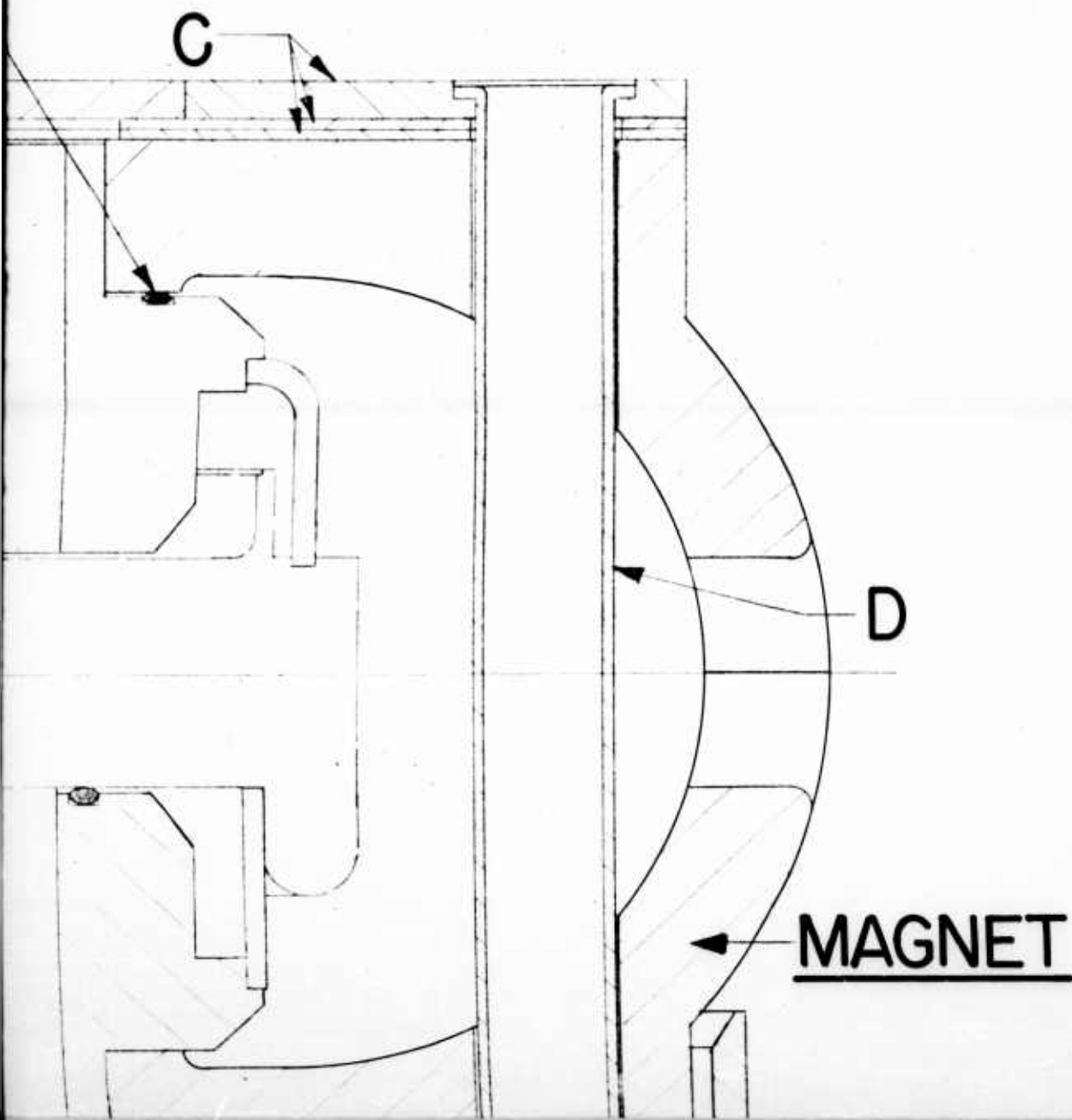

3

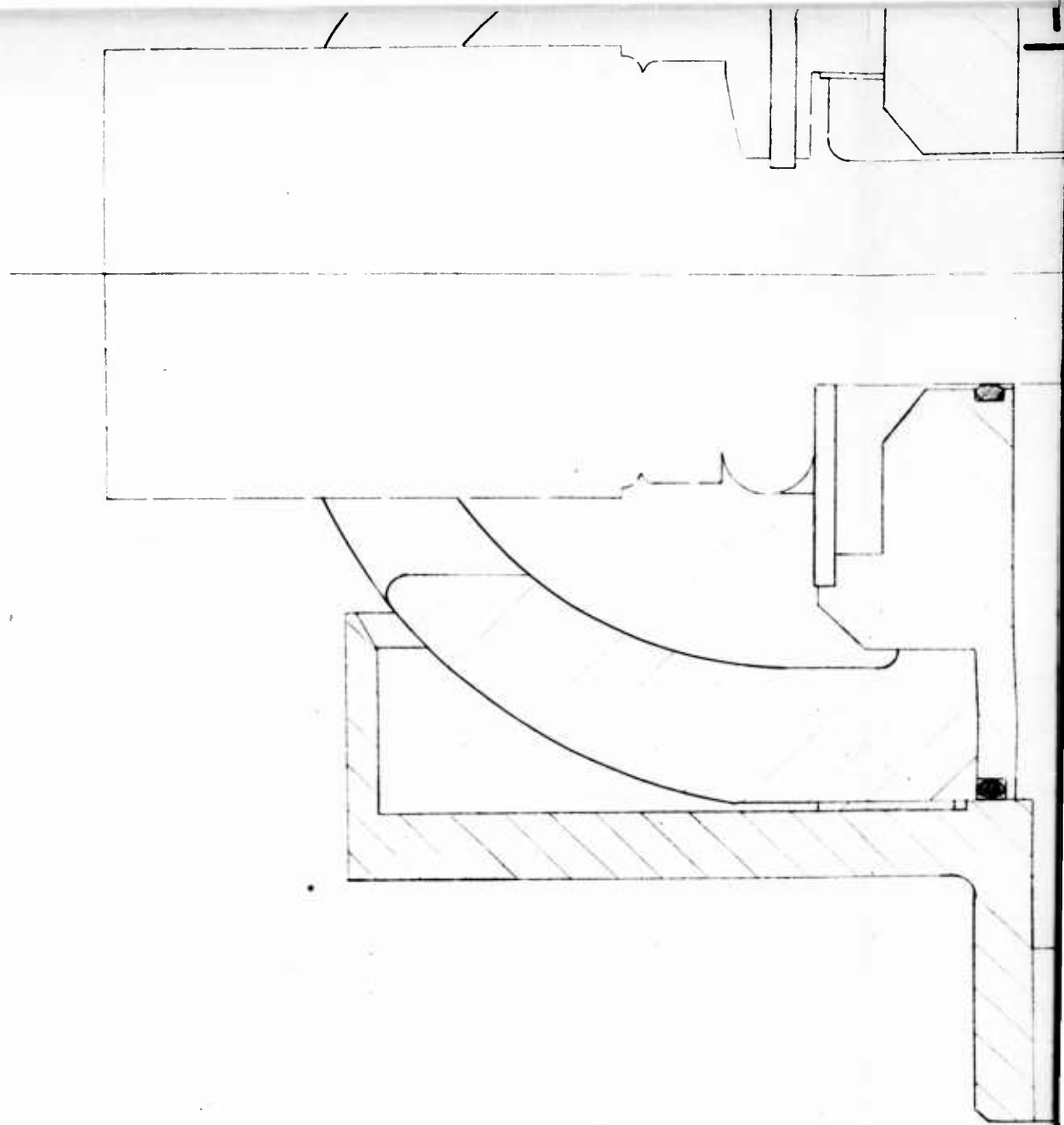

ORIGIN

4

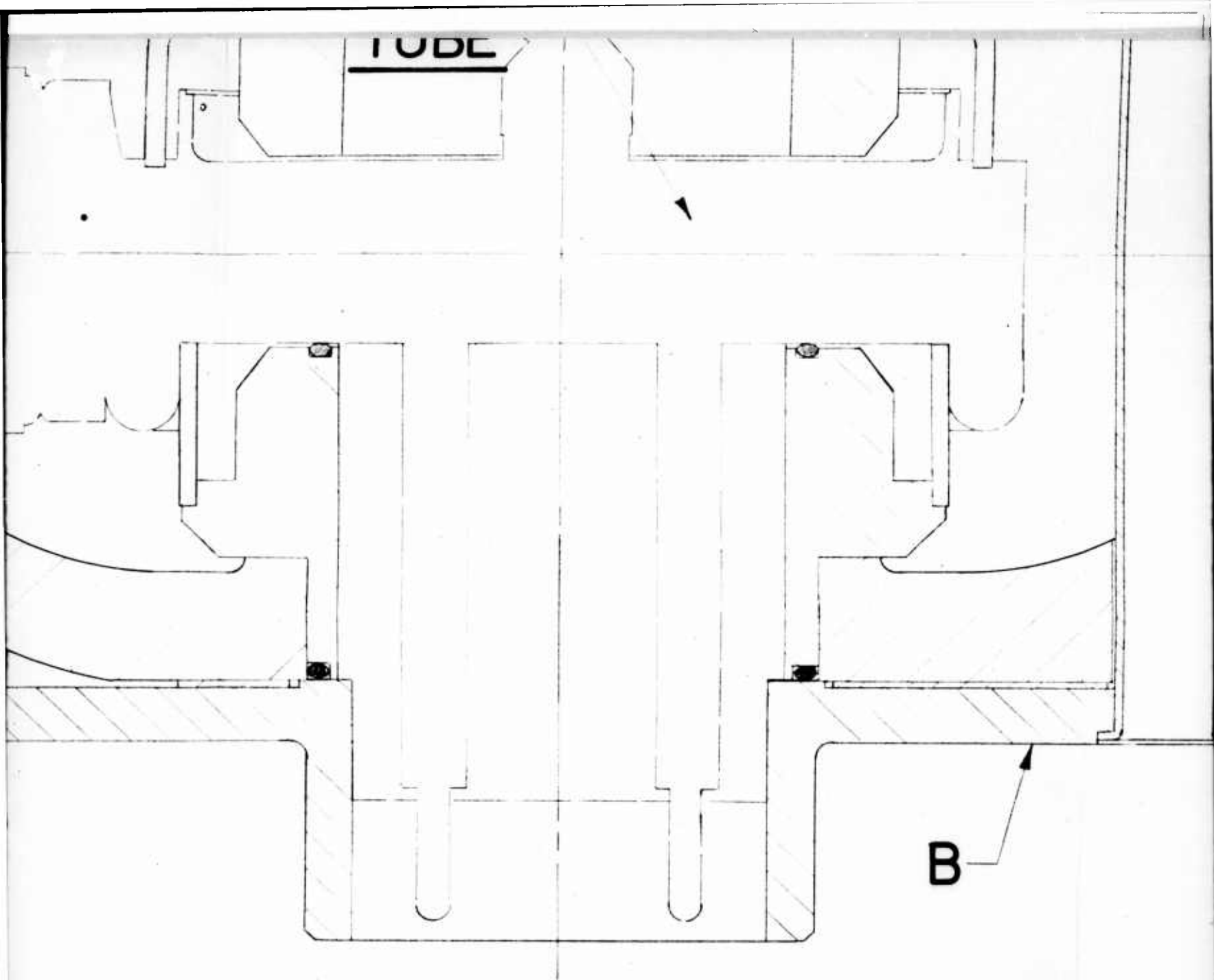

ORIGINAL DESIGN FOR PACKAGING

FIGURE 4

5

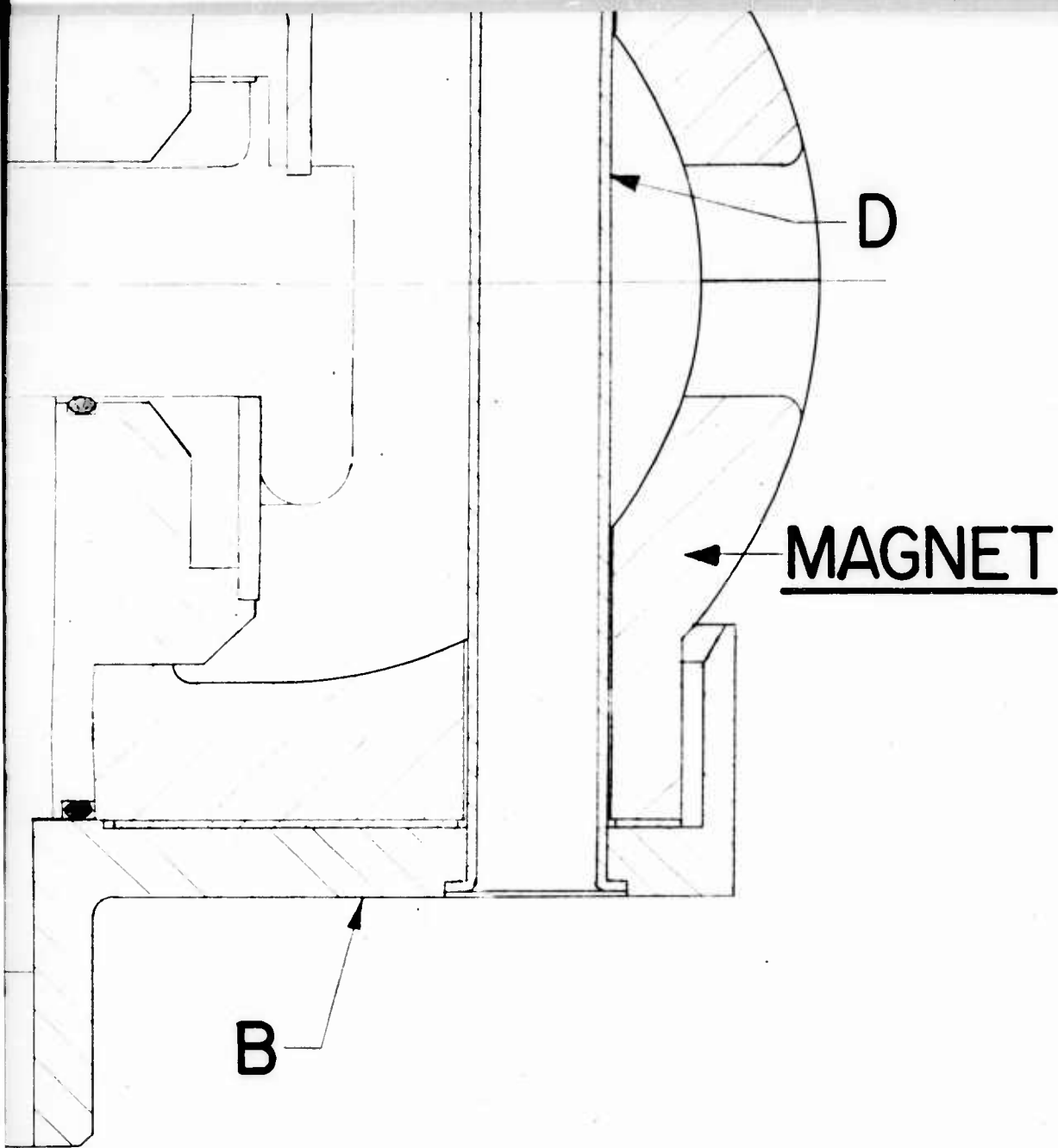

OR PACKAGING

6

in order to allow ease of assembly and disassembly of the tube and external fittings.

A design which would require a change in the magnets would have been expensive to do at this time. Also space considerations did not allow enough room for an extra set of bolts to bolt the external fittings on separately to the magnets.

A design was chosen which will use the existing magnets without changes and yet permit separate assembly and disassembly features for the different parts. A four piece threaded sleeve assembly was designed to replace the flared sleeve clamping method. Figure 5 shows the new threaded sleeve assembly. Screwing the tube parts together eliminated the high pressures required to flare the stainless steel sleeves. All of the new parts were designed with ease of fabrication as a major consideration thus permitting automatic machining methods and keeping costs to a minimum. Two of the parts were designed to be made of hex shaped bar stock. This choice eliminated the need for expensive milling machine work on the finished parts. Automatic machining methods are employed in machining the hex shaped material.

Figure 6 shows a cross sectional view of the new clamping method. This new design independently holds the tube to the lower magnet half; clamps the top magnet half, magnet cover and shunts to the assembly; and last, permits the mounting base to be bolted on to the assembled tube. This last operation will be done before shelf testing the tube. At the end of the shelf test holding period, the tube will be given a post-final electrical test before shipment. This new packaging method is more flexible and allows close control at each step of the packaging operation.

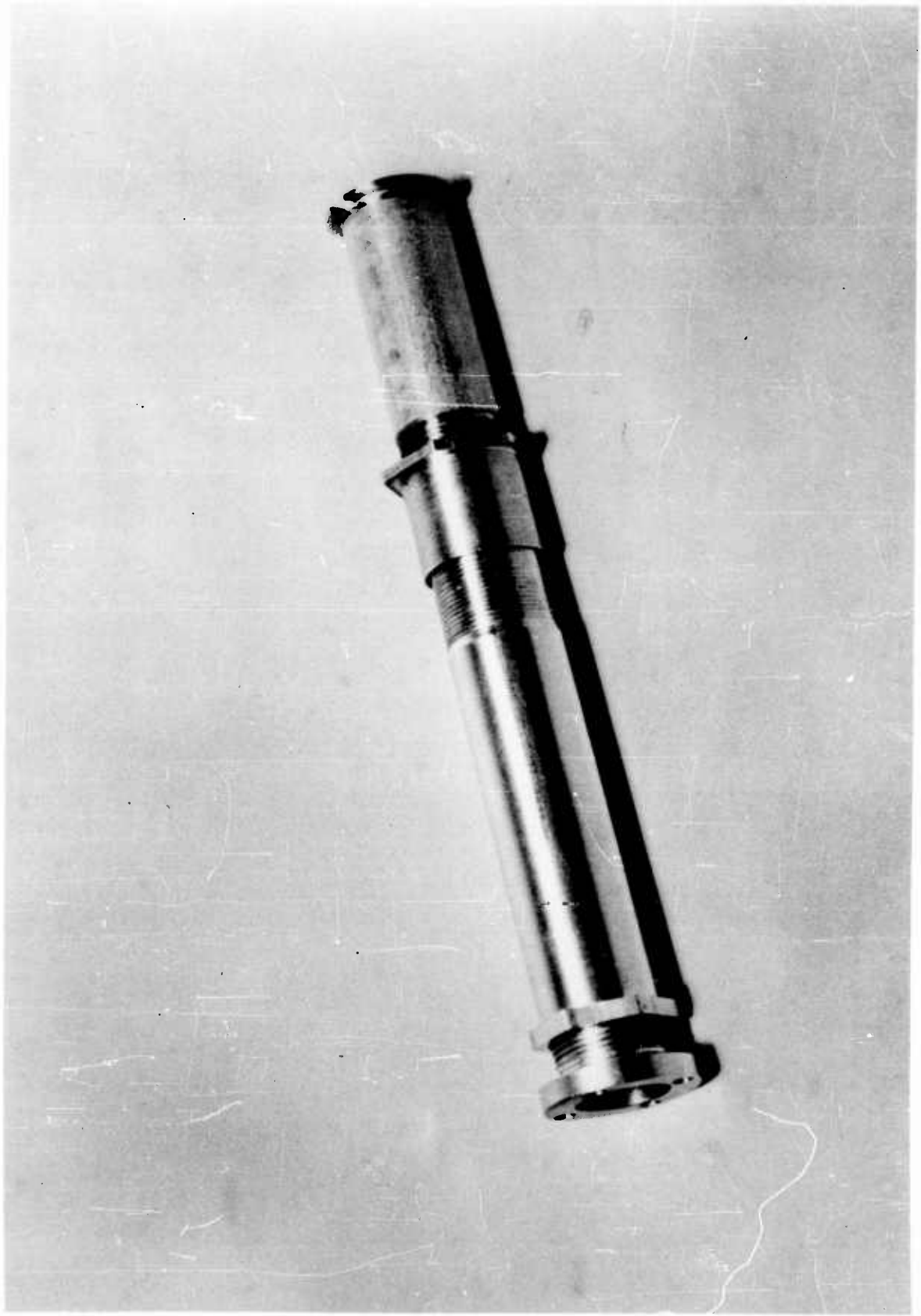

TUBE CLAMP SLEEVE ASSEMBLY

FIGURE 5

1

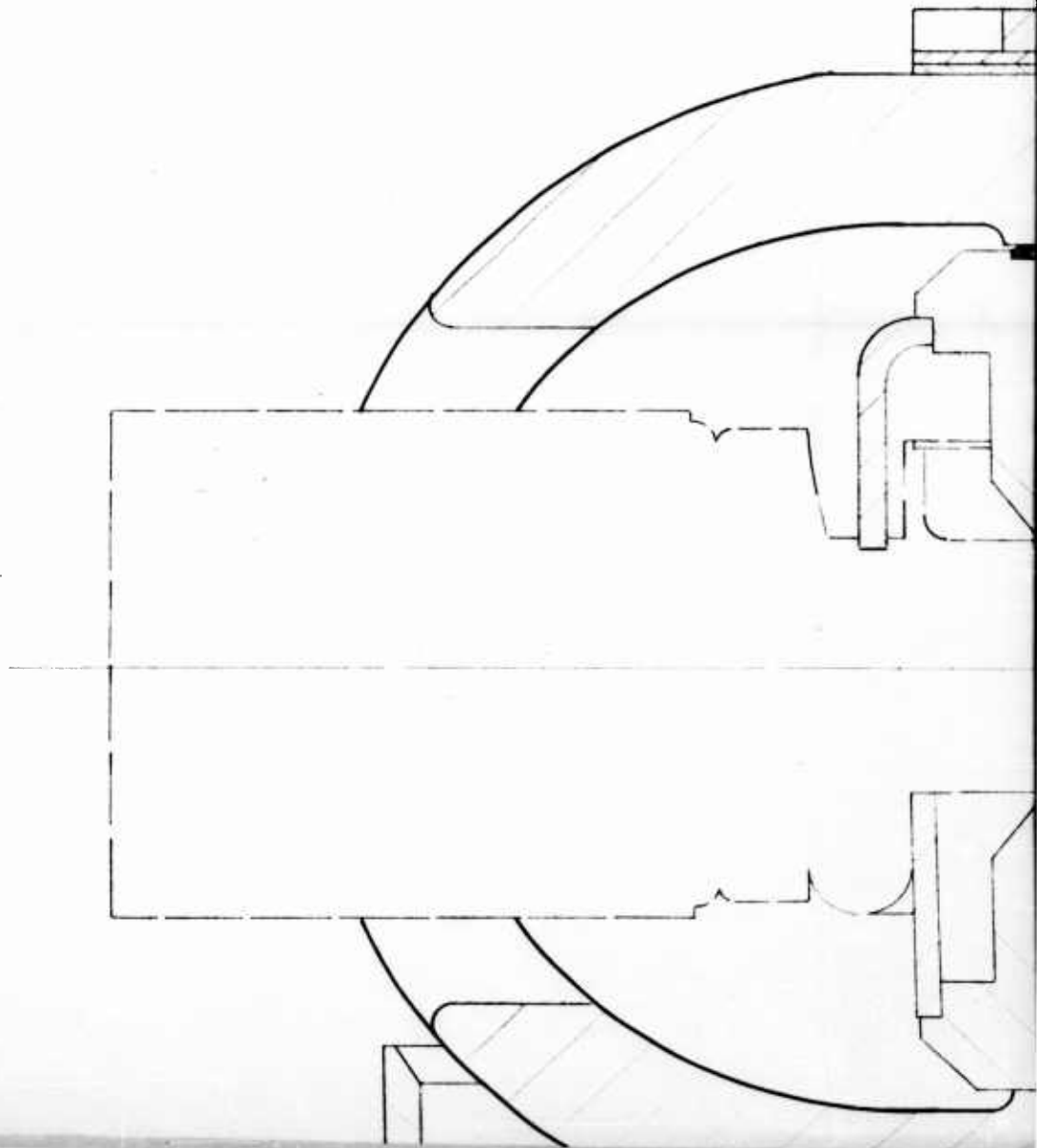

2

TUBE

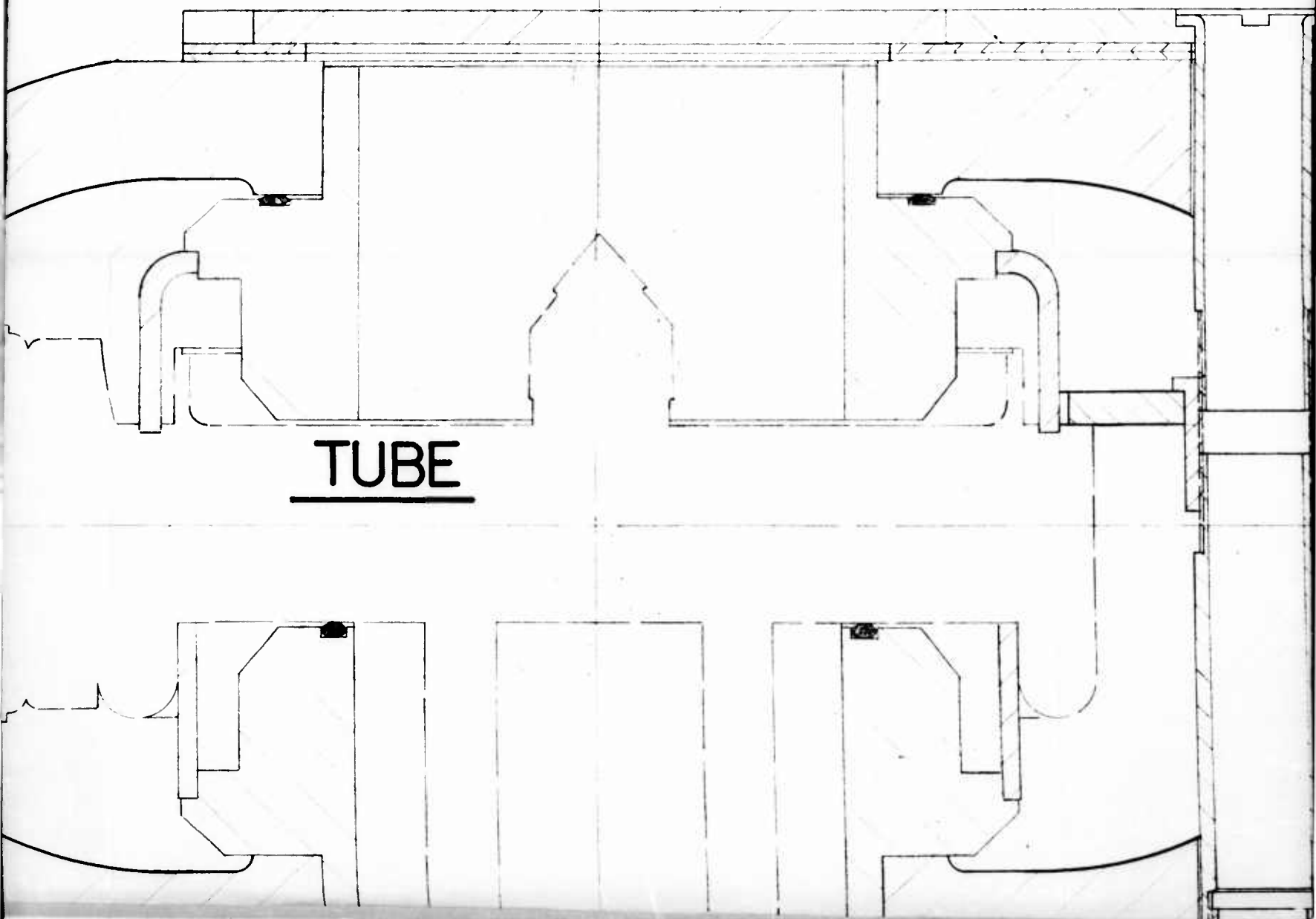

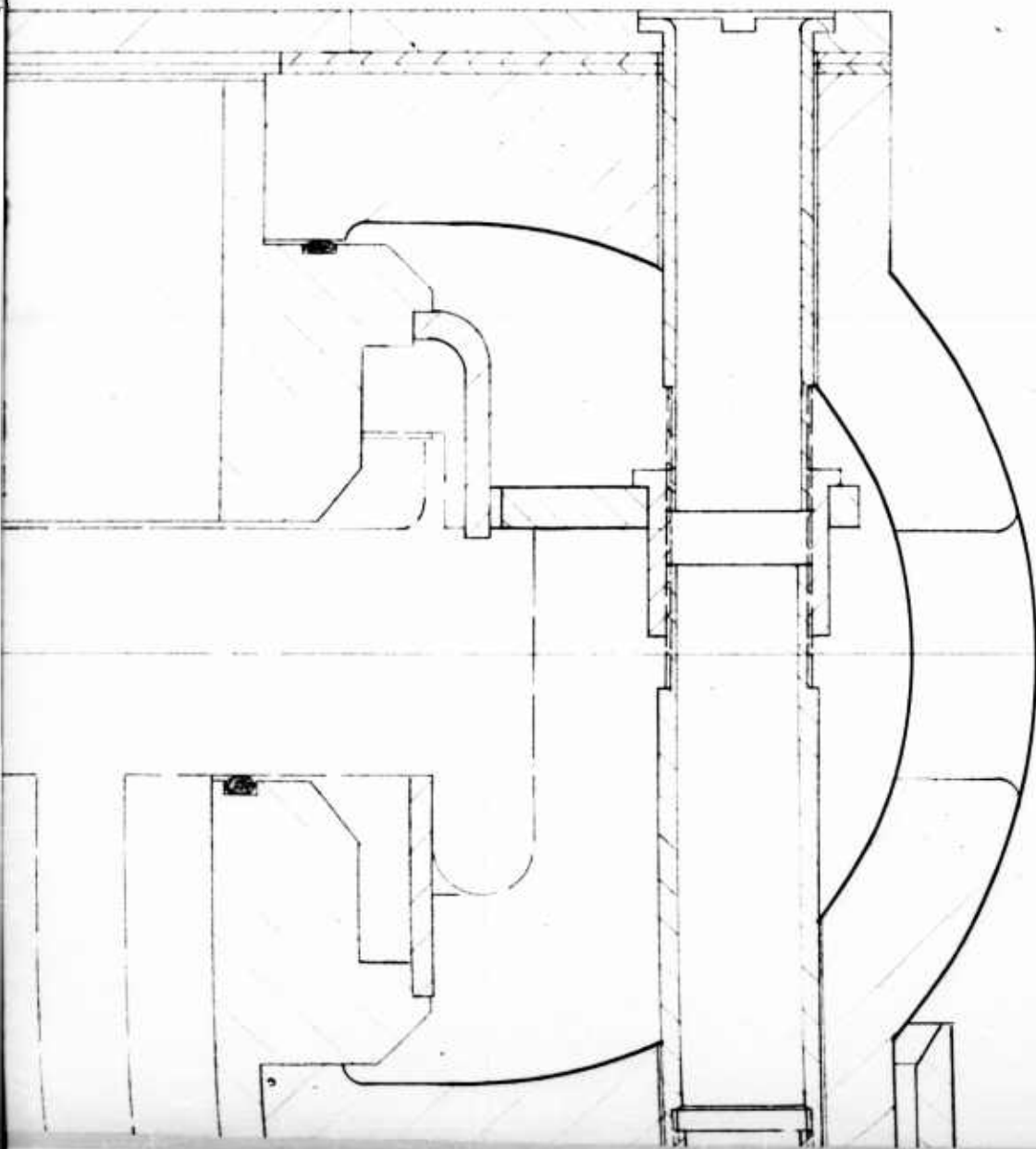

3

MAGNET

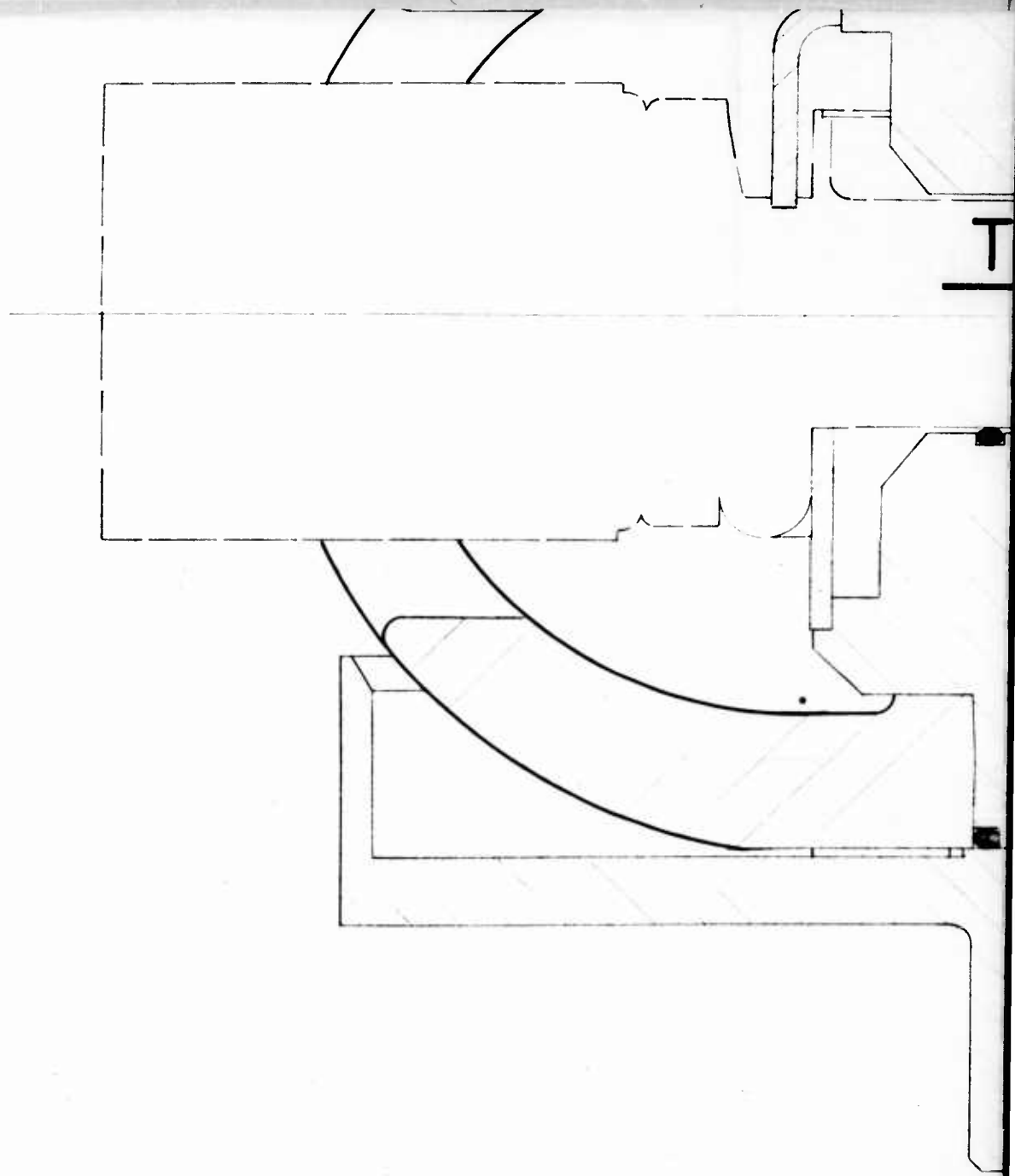

T

MODIF

4

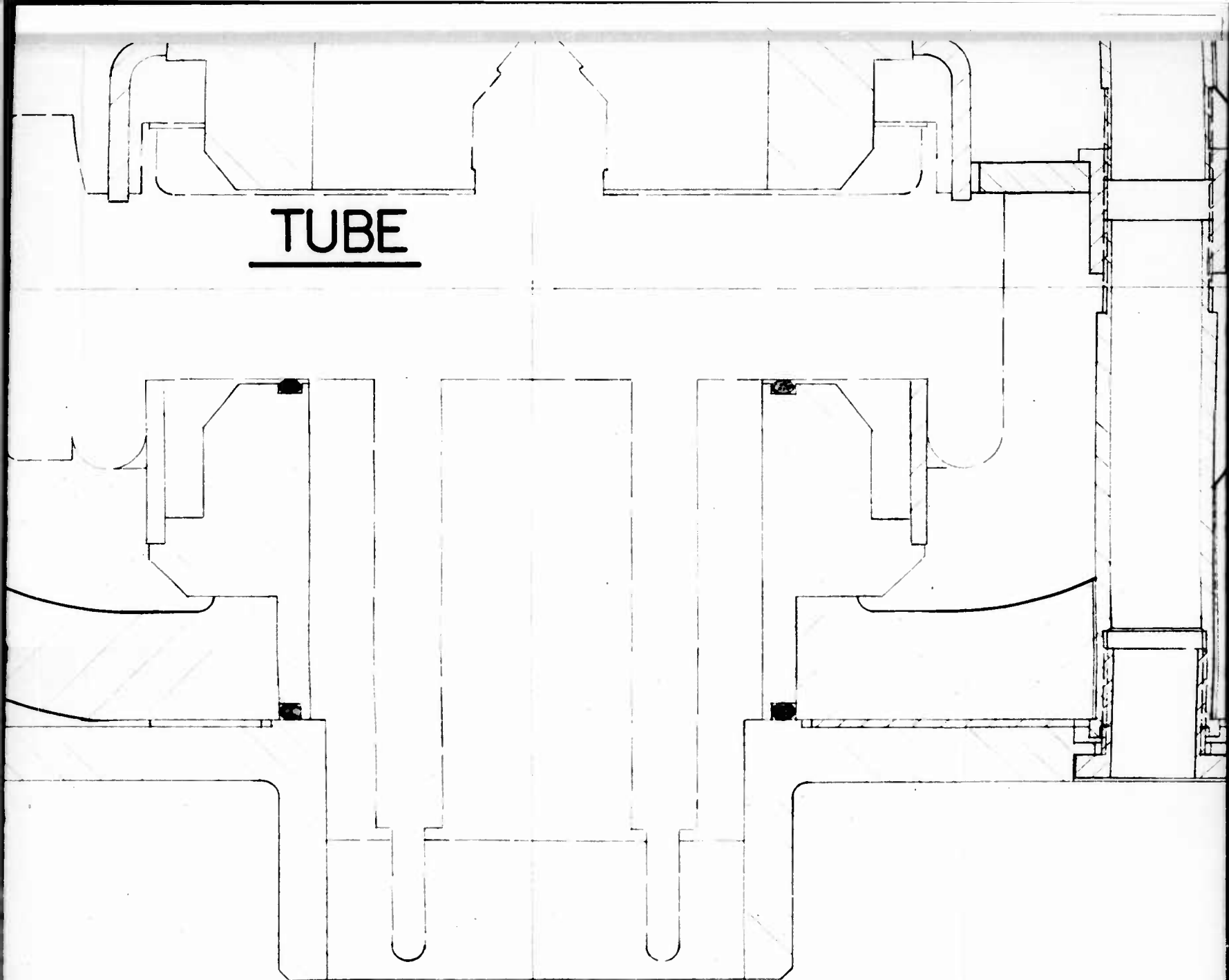

MODIFIED DESIGN FOR PACKAGING

FIGURE 6

5

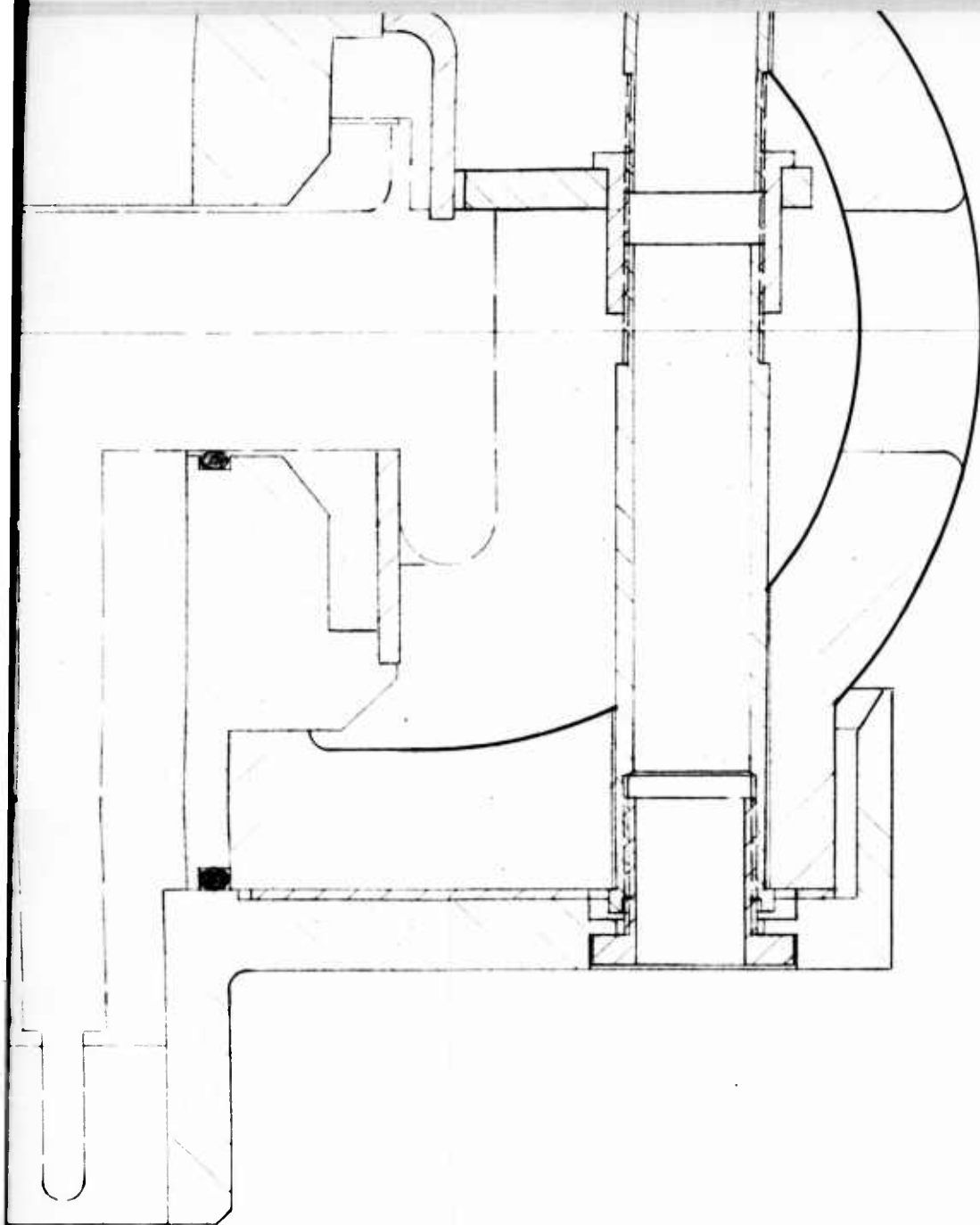

MAGNET

N FOR PACKAGING

FIGURE 6

6

A prototype set of parts was ordered to check assembly feasibility. Figure 7 shows a band 8 tube using the new designed package during different stages of assembly. In the final operation the mounting base is fastened with the three threaded bushings shown.

This same design will work for tubes in bands 6 to 8.

The design for band 5 has been modified to the same design and some of the parts are common to the design in bands 6 to 8.

This new design is also being adapted to the band 1 tube.

A jig was designed to accurately hold all the external fittings parts during assembly. Figure 8 shows the final assembly jig before any assembly of parts. Figures 9 to 11 show the different stages of assembly. In the initial assembly stage the sleeves and the lower magnet half are fitted on the jig. Then the magnet pole pieces and the tube are assembled and clamped to the lower magnet half. In the third stage the top magnet half and the magnet cover and shunts are fastened on forming a finished assembly ready for electrical testing. After electrical testing the tube has the mounting base fastened as shown in the third stage of Figure 7 and is put on shelf test prior to shipping.

All tubes from bands 1 through 8 will be assembled on this jig. The use of this jig produces consistent finished tube assemblies and assures that all outline dimension requirements will be met.

Item 2 Magnetic Shunt

The magnetic shunt in the collector region has been redesigned to prevent any possibility of overheating due to beam interception. The shunt is made of a high grade of magnetic stainless steel. Stainless steel unfortunately has very low heat transfer capabilities and

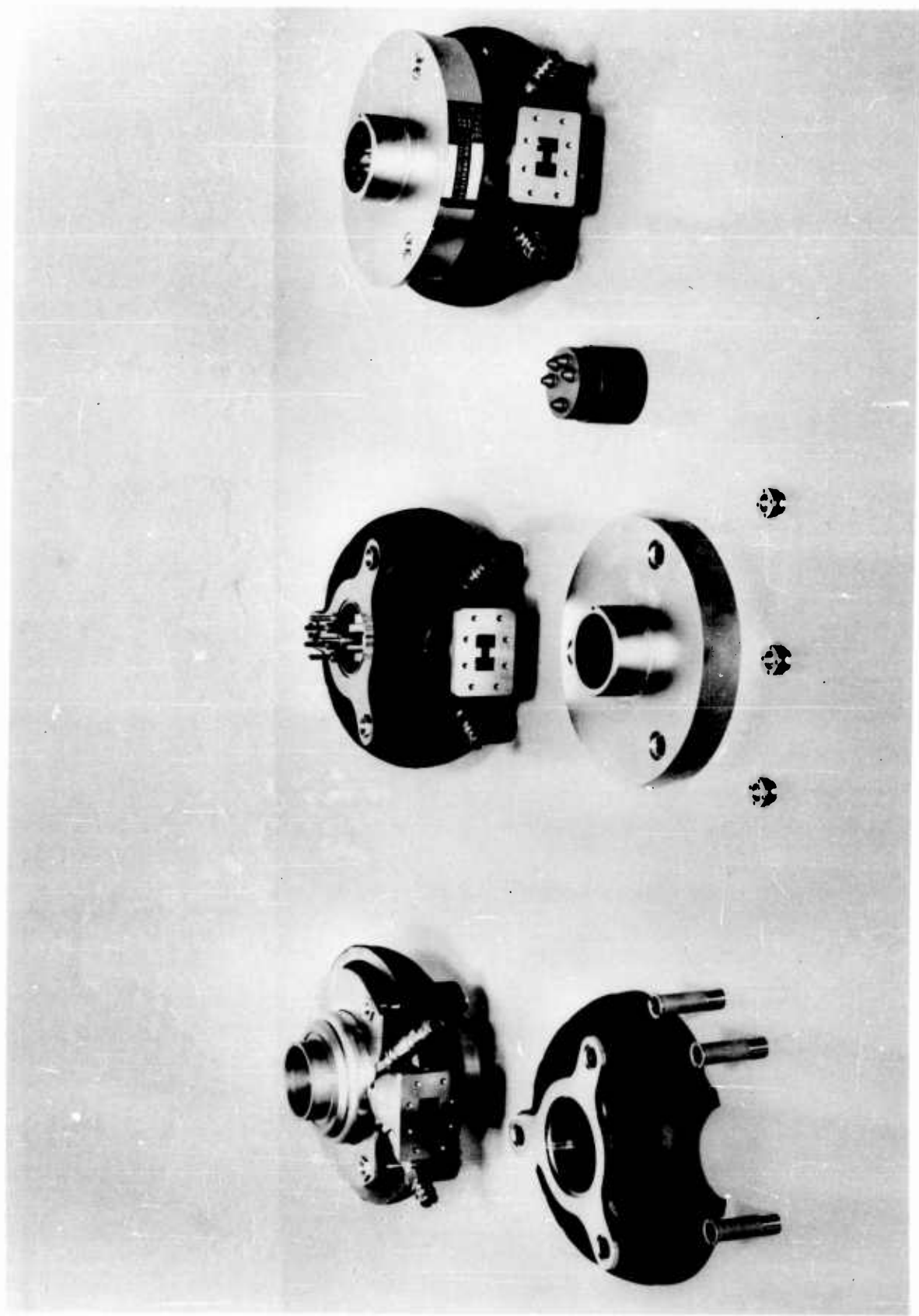

INTERMEDIATE STAGES OF PACKAGING

FIGURE 7

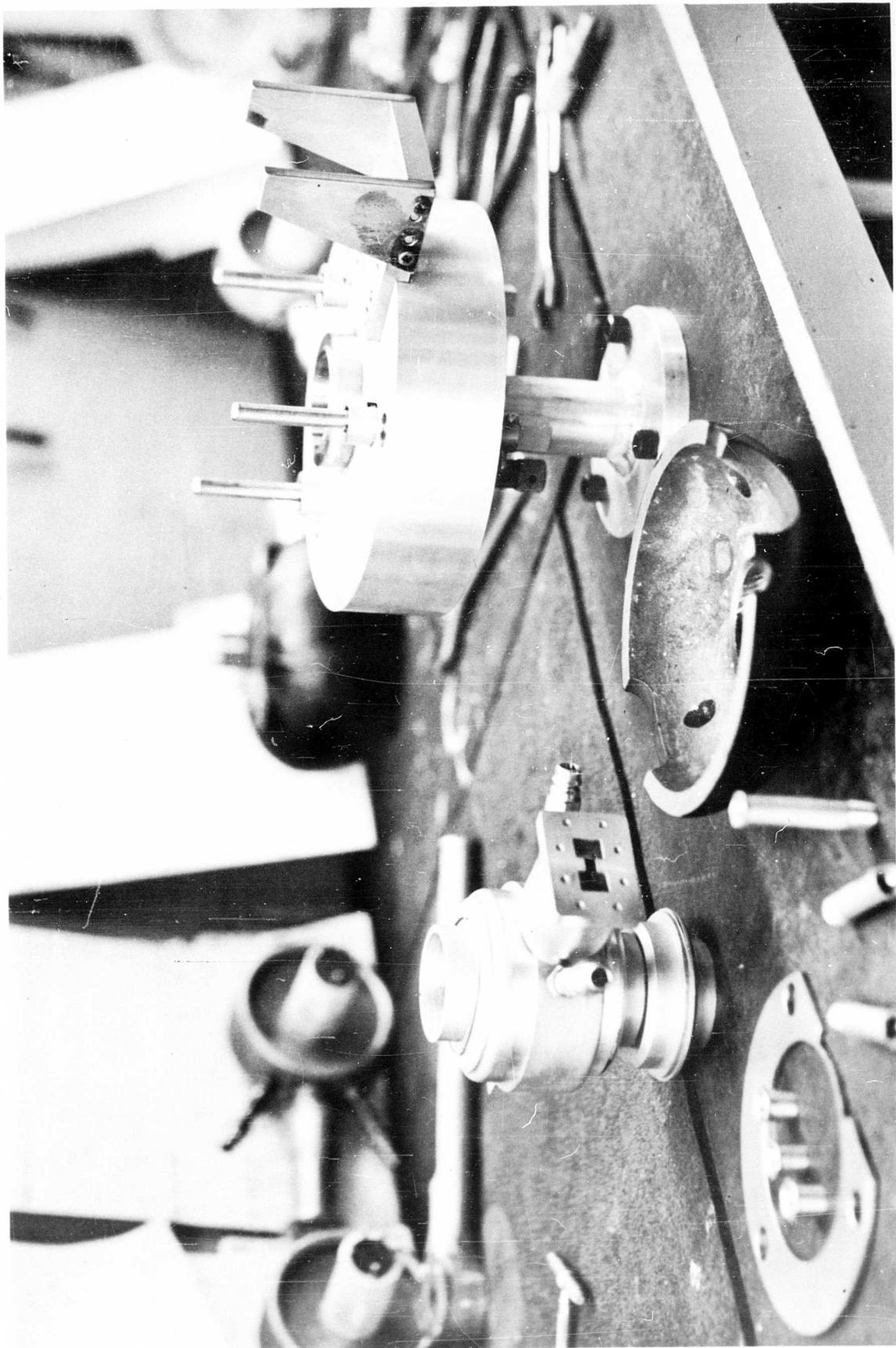

FINAL FITTINGS JIG

FIGURE 8

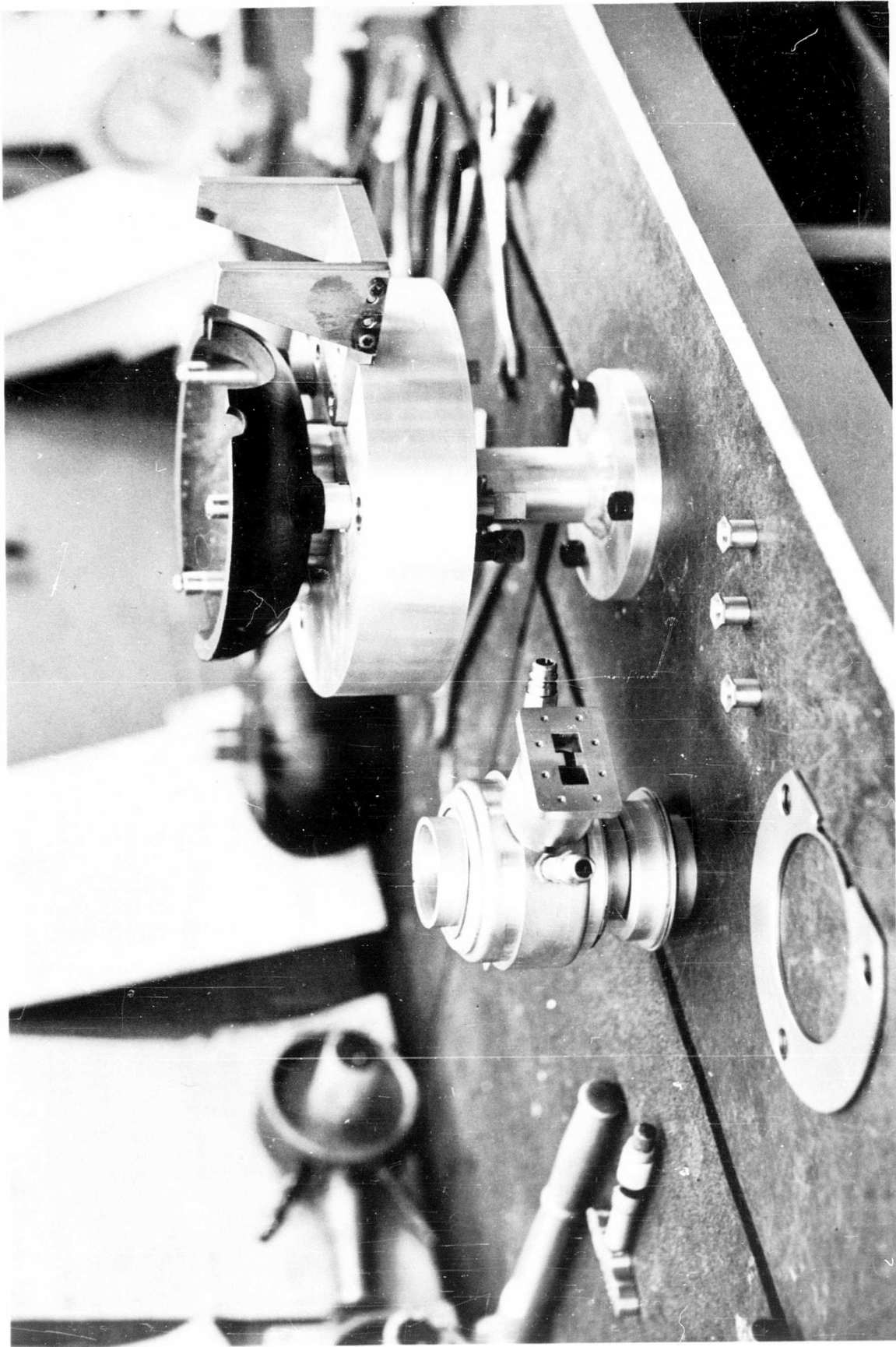

INITIAL ASSEMBLY STAGE

FIGURE 9

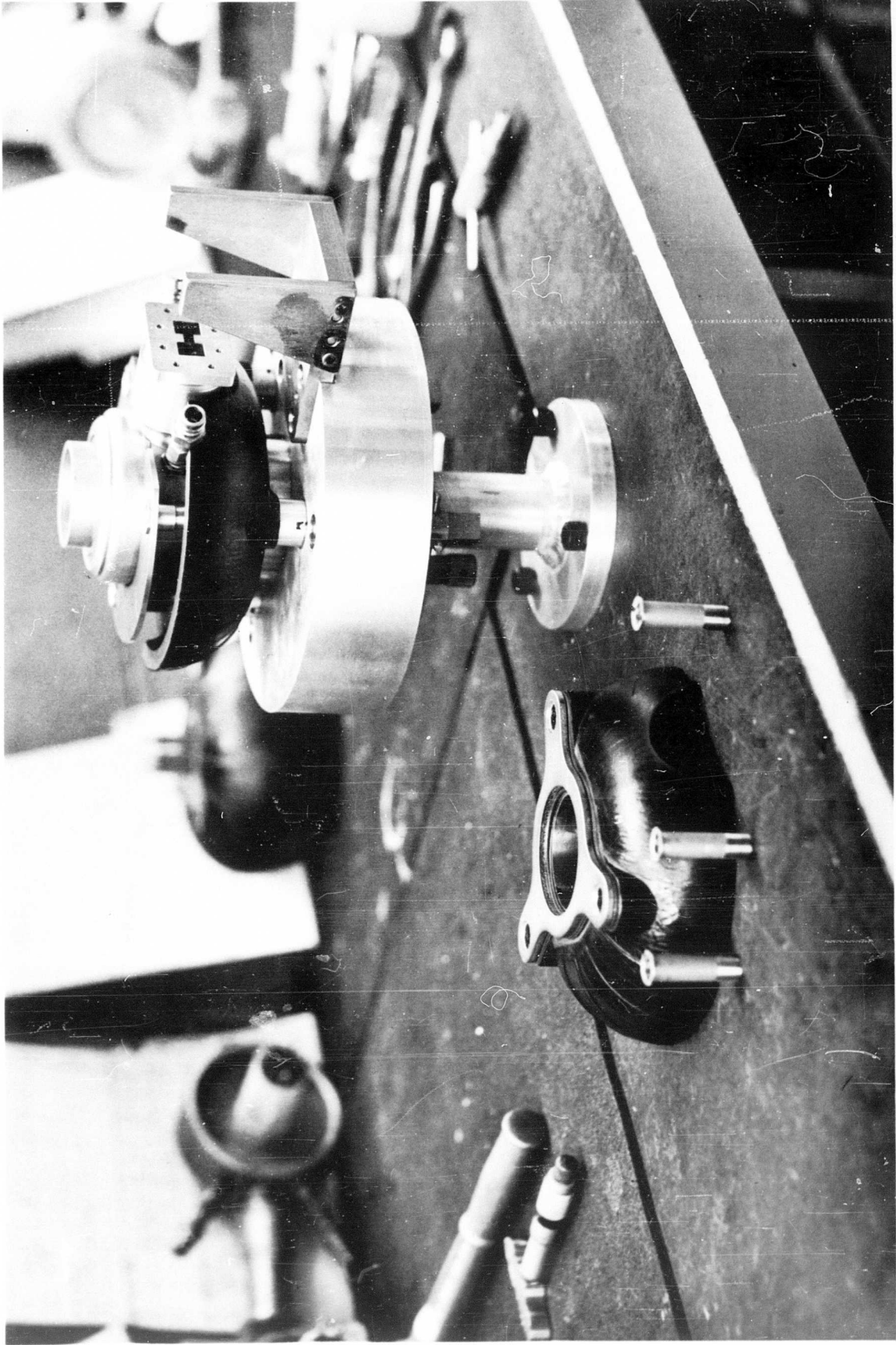

SECOND ASSEMBLY STAGE

FIGURE 10

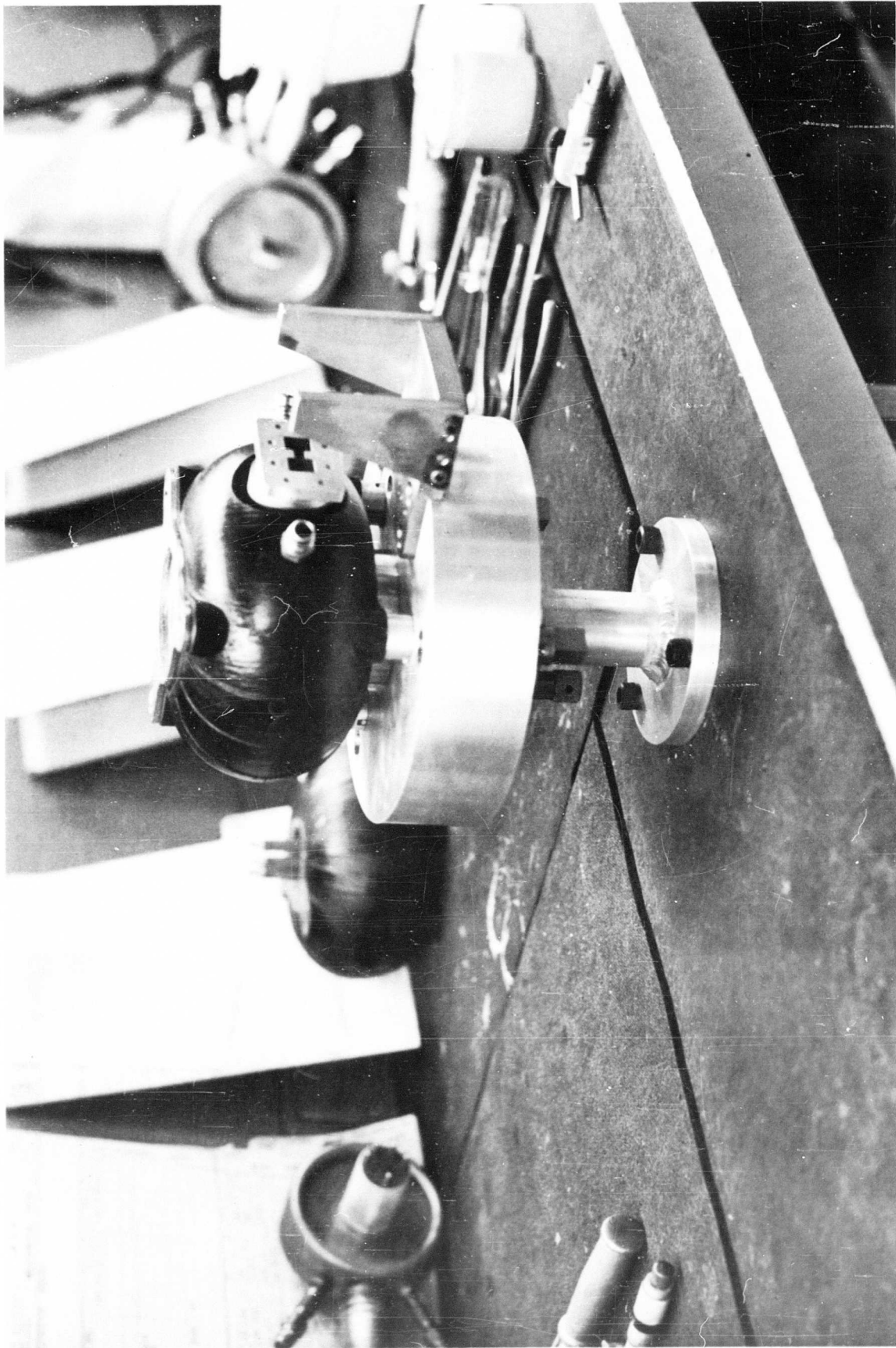

THIRD ASSEMBLY STAGE

FIGURE 11

overheating and subsequent outgassing is a very distinct danger in the event of electron interception. This is most likely to happen at bands 7 and 8 where due to delay line size the beam must be correspondingly more tightly focused. This results in a dense beam for these higher frequency tubes. The magnetic shunts were relocated in an enlarged collector to prevent any possible failure due to outgassing from overheated magnetic parts.

Item 3 Exhaust Tubulation

The previous top end plate design is shown in the subassembly drawing in Figure 12. This subassembly is the last cover put on the assembled tube before high temperature vacuum exhaust and provides the means for fastening on to the vacuum pumps. The copper seal flange "A" and adapter tube "B" and tip-off tubulation "C" have all been replaced by a single flared copper tube. Two precious metal brazes are eliminated together with their separate brazing runs. The simplified design is also shown in Figure 12.

All of the exhaust stations have been modified to accommodate the more economical flared tube seals. This has not only lowered manufacturing costs for parts but has lowered processing cost also. Formerly if a vacuum tight seal was not achieved or was lost at the surface of the flange "A" the whole top end plate assembly would have to be replaced. The flared design only requires that the flared portion be trimmed off and the end re-flared before fastening tube to exhaust station again. This has lowered costs and speeded up processing time for all tubes.

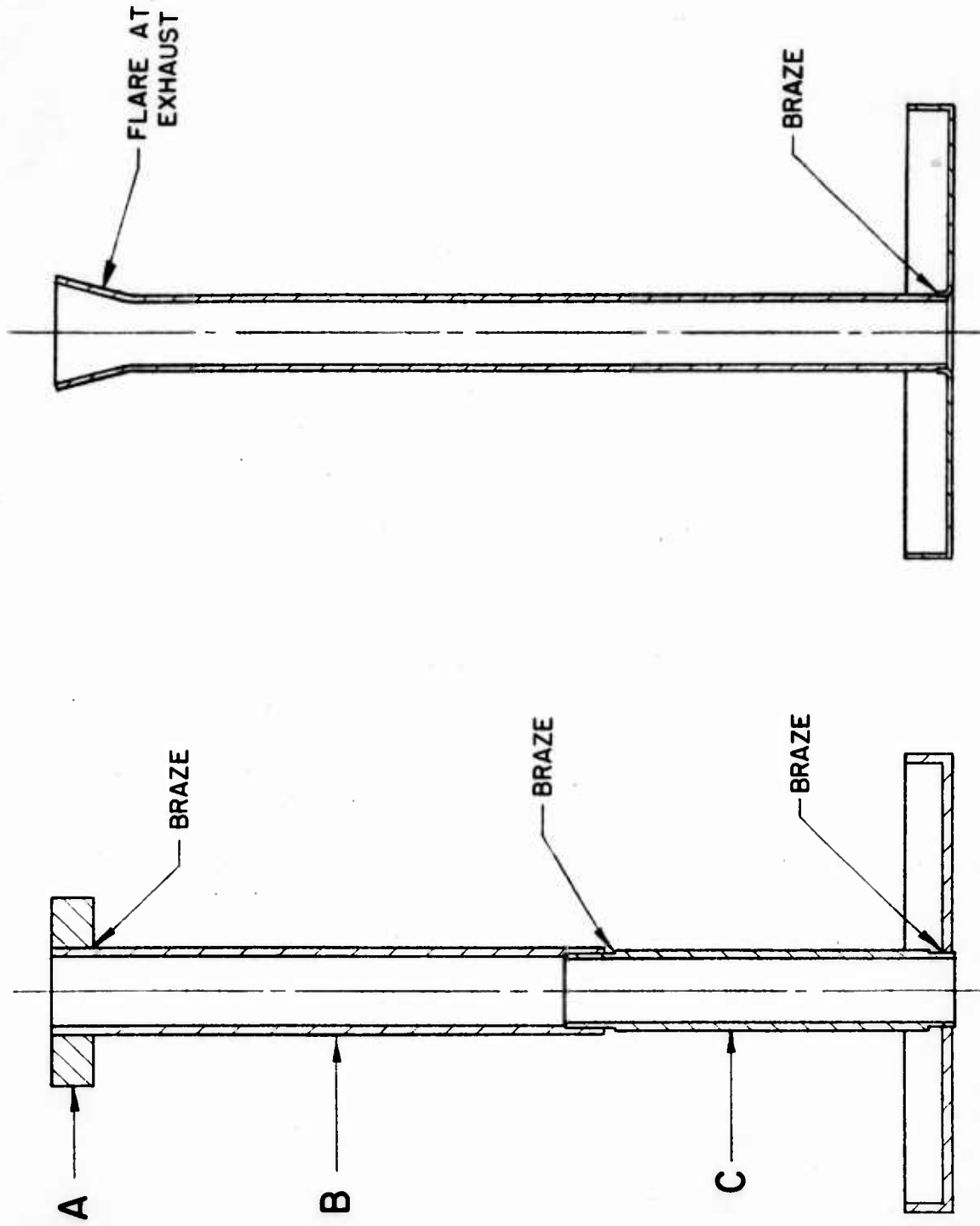

FLARED TUBULATION

FLANGED TUBULATION

EXHAUST TUBULATION

FIGURE -12

Item 4 Sized Top End Plate

The top end plate design was modified to permit a change in method of fabrication and lowered manufacturing cost. Dies were made to manufacture the part with as many of the dimensions to size required as possible. Previously the part was made from a standard thick drawn cup with all of the surfaces finish machined. The redesigned part has only two machine cuts for parting to dimension. The technique used in manufacture is a drawing die that sizes the wall thickness of the cup to a consistent thinner wall than the thickness of the material. Close control of dimensions is achieved to a far greater degree than with conventional drawing methods. This method of manufacture has been applied to tubes in bands 5 to 8.

Item 5 Sized Body Ring

The sized wall thickness drawing method has also been applied to this part. The large diameter and relatively thin wall of this vacuum tight part made gauging very difficult on the finished parts. The new method has held the critical dimensions to consistently close tolerances which was impossible with the previous method and has made individual parts measurement practically unnecessary.

Item 6 Weighed Welding Stand

A welding stand was designed to provide a consistent pressure from tube to tube during the final welding operation. Figure 13 shows a view of the new fixture designed. This fixture applies pressure on the top end plate assembly and provides freedom of rotation for the last welding operation. The pressure applied is equal to the atmospheric pressure on the end plate when the tube is

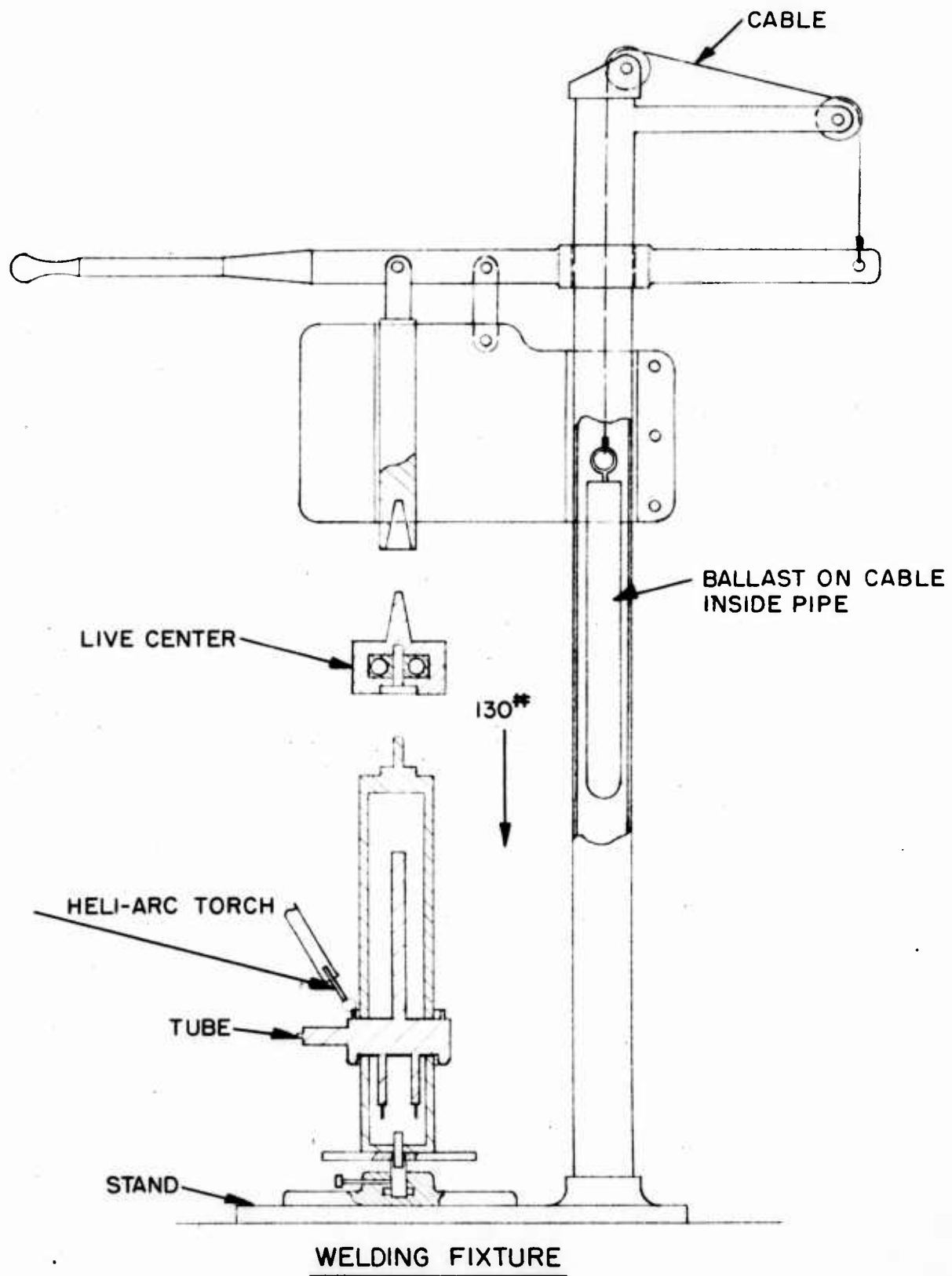

FIGURE 13

vacuum exhausted. Thus, during all the critical phases of tube assembly and exhaust, internal parts have a predetermined pressure. This constant pressure is utilized in the design of the tube to provide a firm ceramic to metal contact in order to quickly stabilize the operating temperature of the sole. The sole temperature affects the frequency stability of the tube. Control of this critical phase of tube assembly has helped meet the frequency stability requirement.

Item 7 Electrical Input Insulation

A single molded silicone rubber insulating plug for all five electrical inputs was designed. This new part replaced 5 separate parts and lowered the cost per tube. The assembly of the tube at fittings is also simplified in the packaging operation thus resulting in lower costs. Figure 14 shows the new single unit plug and the previous set of parts it replaces.

Item 8 Crown Alignment

A new crown alignment method was perfected for the band 7 tube. This new method provided both circumferential and radial alignment features for the two delay line halves during initial body assembly operation. The previous method required a jig for radial alignment on centerlines and then spacers were required to be placed between the delay line fingers for circumferential (angular) alignment. The new design has indexing slots on each crown for use both during the crown making operation and the later body assembly stage. A dual purpose crown stacking assembly jig aligns both crowns on center and with respect to angle. This shortens assembly time and gives more accurate control of this critical assembly operation. Figure 15 shows a before and after view of crowns being assembled

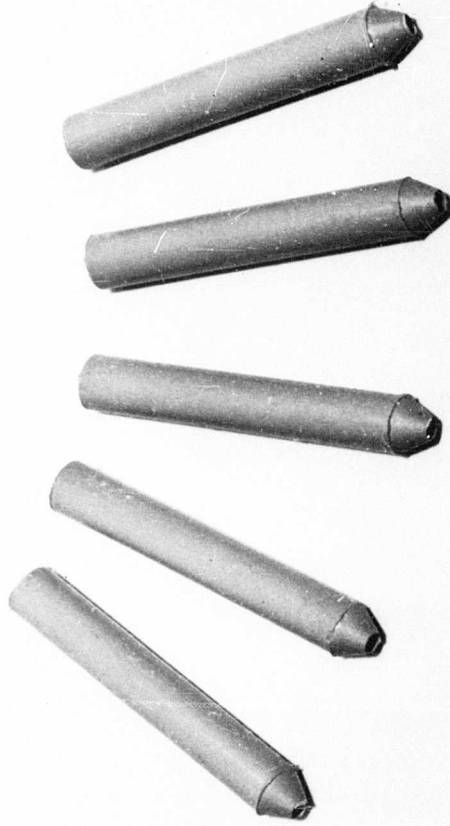
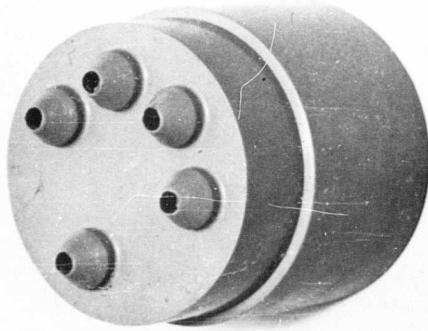
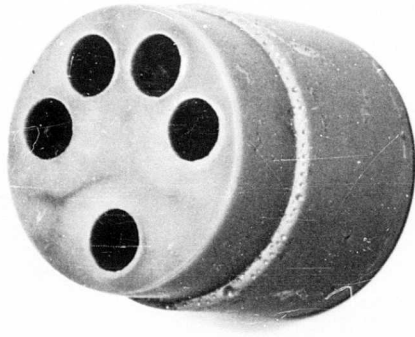

ELECTRICAL INPUT INSULATION

FIGURE 14

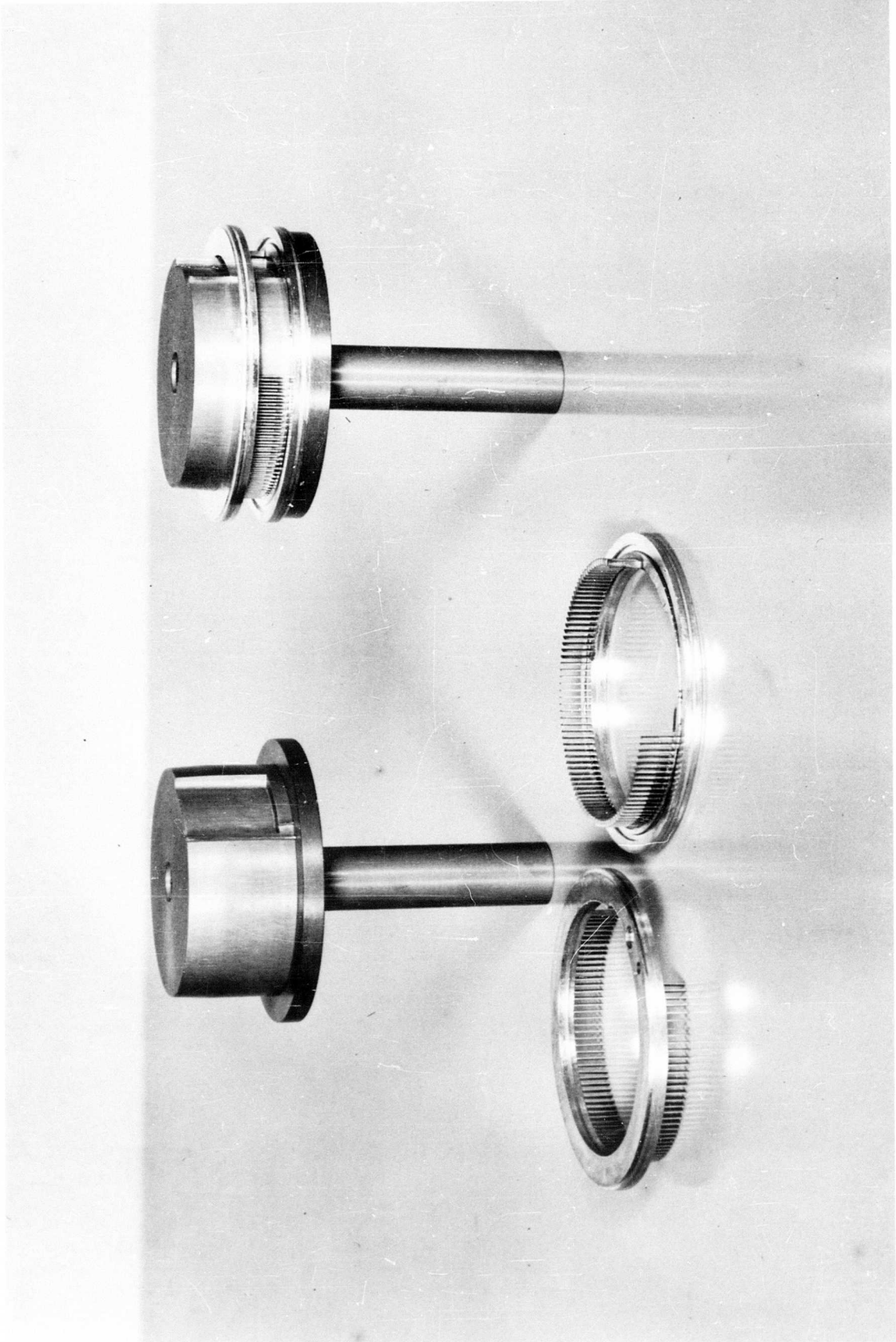

CROWN STACKING JIGS AND CROWNS

FIGURE 15

with the new crown alignment jig. This method is being considered for other tube types of the L-3720 family.

Item 9 Finger Brazing Jig

A dual purpose two piece jig was designed to accurately hold the fingers during the brazing operation. The tungsten fingers are pressed into the copper and are thereby held at the base but they have to be held at the tip to keep them from leaning over during the time the brazing alloy is melted. Previous attempts to use a "hot" brazing jig with accurate slots had failed due to dimensional control problems with the depth of the slot. The slightest amount of warp would make a jig useless. An alternative method was used which spaced the fingers around a ring with small stainless steel spacers. This method was tedious and the results were barely acceptable at best due to the cumulative effect of spacer fits.

A new jig was designed with a separate "stress relieved" inner ring to accurately hold the radial position of the fingers. The angular position is held within the allowable limits by a slotted cap ring. Figure 16 shows a crown assembly together with the brazing jig.

Item 10 Ramp Profile Milling

Nonlinear surfaces are usually required in the output ramps of MBWO's for rf impedance matching. Most ramps have a nonlinear variation in thickness calculated to give an exponential change in impedance versus electrical length of the output system. The method perfected for reproducing this nonlinear surface on large quantities of parts uses a master profile in conjunction with a modified milling machine. A hydraulic actuated table tracks the master

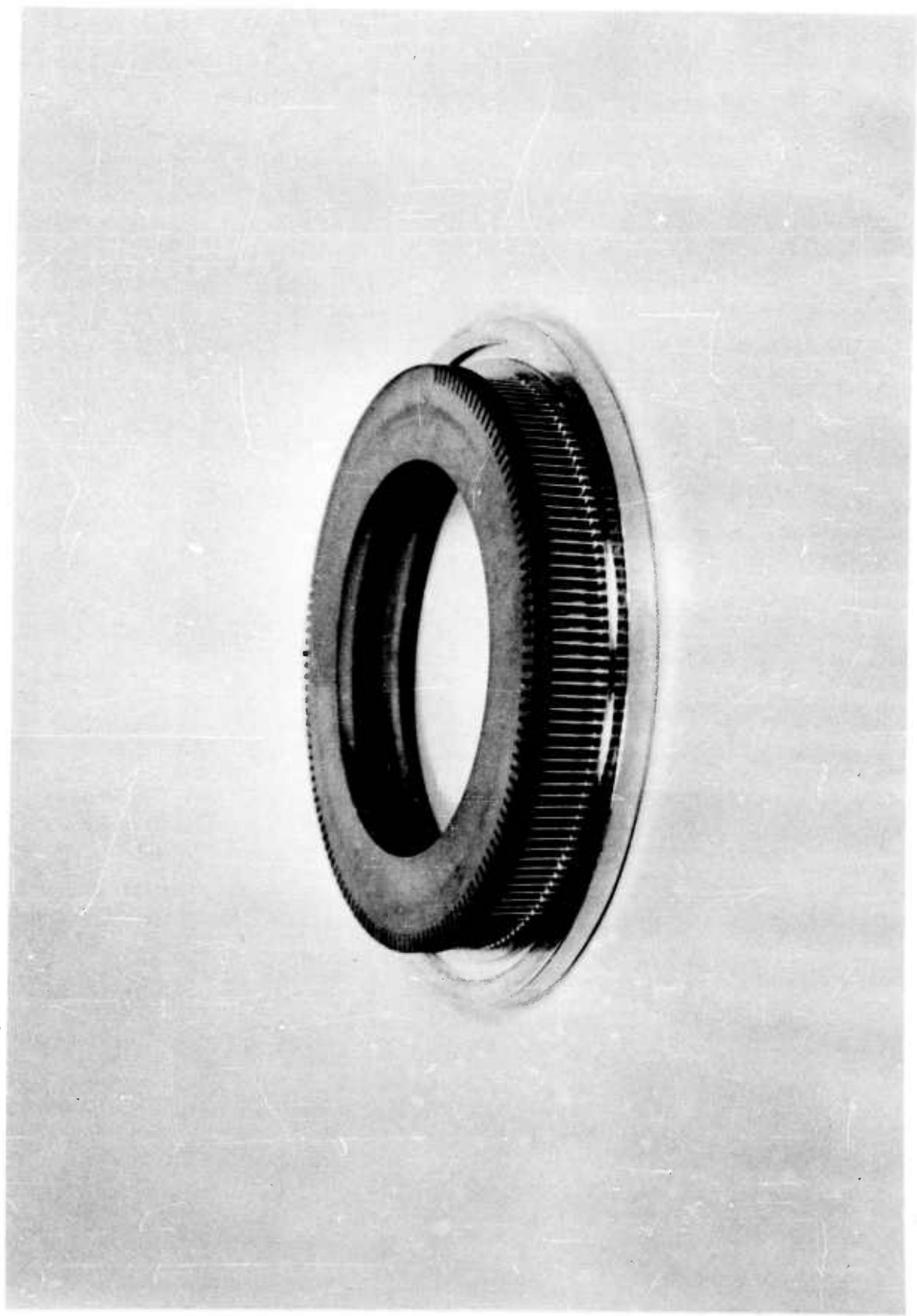

FINGER BRAZING JIG & CROWN

profile and reproduces this profile inexpensively in large quantities of parts. Figure 17 shows a ramp set up in a contour milling machine after milling the profile. This technique is used in tubes in bands 4 to 8.

Item 11 Automatic Finger Cutting Machine

Large quantities of tungsten fingers are used in the delay lines for the tubes in bands 4 to 8. As many as 190 are required in the band 8 tube. Figure 18 shows an automatic finger cutting machine which cuts the fingers to length from the formed tungsten wire to an accuracy of $\pm .0005$ inch. Six foot lengths of stock are set up by the operator and the machine automatically feeds and cuts the tungsten with an abrasive cutting wheel. This has lowered manufacturing costs over the previous operator actuated method.

Item 12 Hobbed Horn and Ramp

The copper hobbing technique has been perfected to punch a long non-symmetrical inside surface. This process has made it possible to combine the lower ramp into the horn blank. Figure 19 shows the hardened steel punch used to form the inside surface of the horn by pressing into solid copper at very high pressures. Parts are included in the figure which shows how the ramp is molded in the inner geometry of the horn. This has not only eliminated a separate part but has also increased reproducibility since all parts are formed by the same punch.

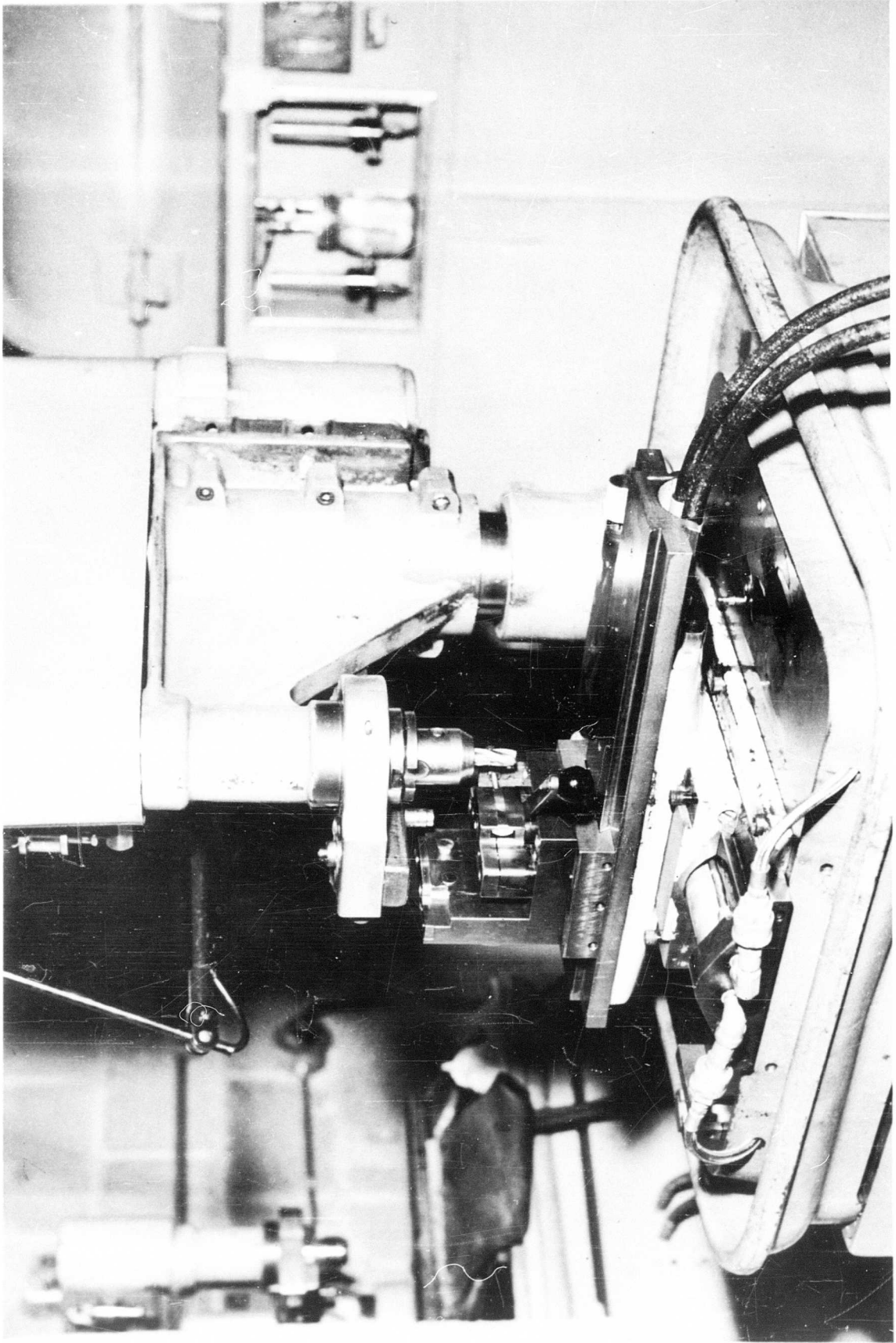

CONTOUR MILLING MACHINE

FIGURE 17

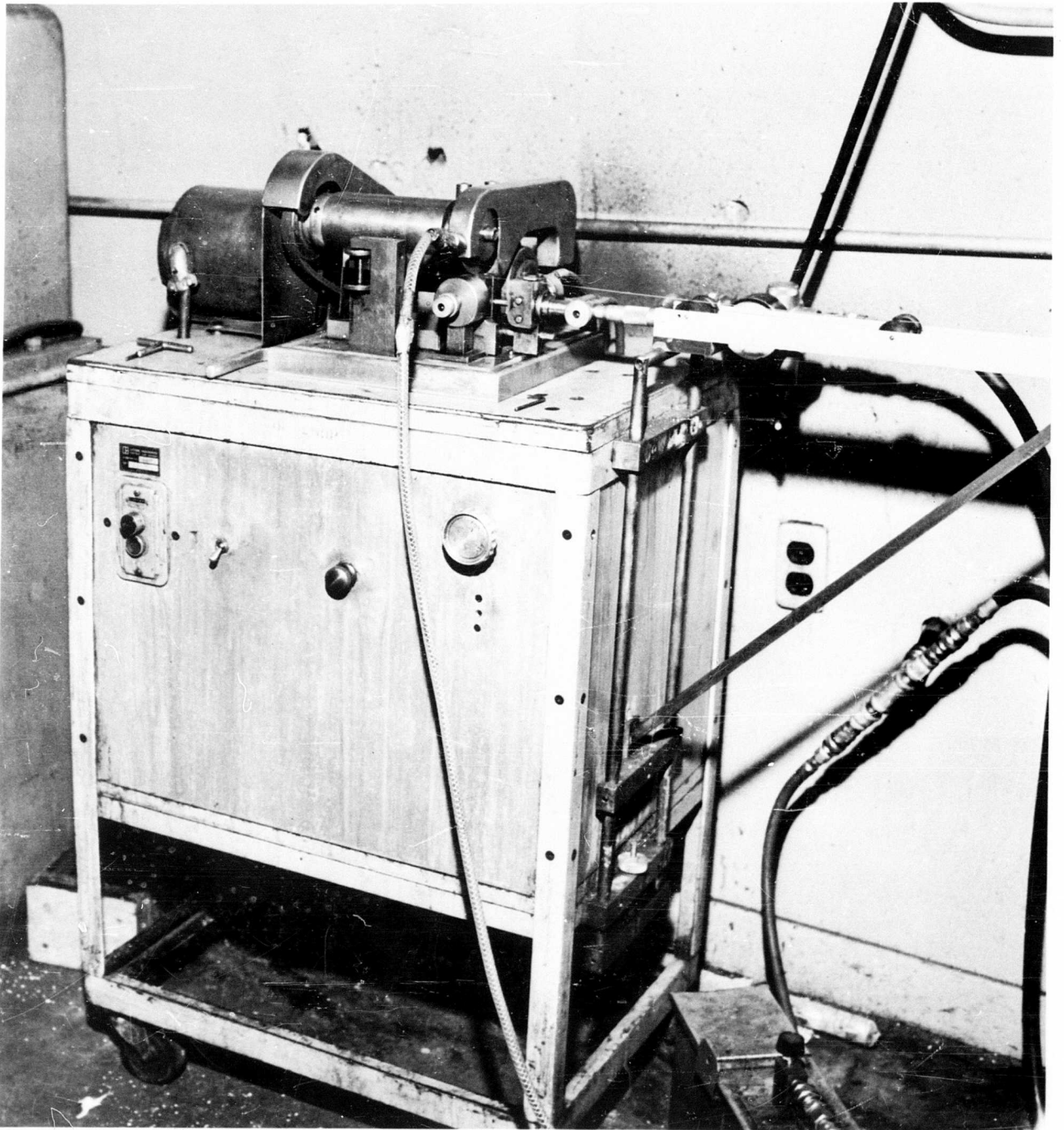

AUTOMATIC FINGER CUTTING MACHINE

FIGURE 18



COPPER FORMING PUNCH

FIGURE 19

F. Program For The Next Quarter

Life testing will continue on new samples of bands 1, 6 and 8 tubes. It is also expected that the first band 5 and 7 tubes will have accumulated appreciable time on life test. Design and process changes of a manufacturing nature will continue to be accomplished as new life test information is evaluated.

UNCLASSIFIED

UNCLASSIFIED