

**UNCLASSIFIED**

---

---

**AD 286 237**

*Reproduced  
by the*

**ARMED SERVICES TECHNICAL INFORMATION AGENCY  
ARLINGTON HALL STATION  
ARLINGTON 12, VIRGINIA**



---

---

**UNCLASSIFIED**

NOTICE: When government or other drawings, specifications or other data are used for any purpose other than in connection with a definitely related government procurement operation, the U. S. Government thereby incurs no responsibility, nor any obligation whatsoever; and the fact that the Government may have formulated, furnished, or in any way supplied the said drawings, specifications, or other data is not to be regarded by implication or otherwise as in any manner licensing the holder or any other person or corporation, or conveying any rights or permission to manufacture, use or sell any patented invention that may in any way be related thereto.

**GINNIE 286 237**

63-1-2  
REPORT NO. FGT-1468  
DATE: 27 June 1967

**GINNIE**

**GINNIE**

**GINNIE**

**GINNIE**

**GINNIE**

**GINNIE**

**GINNIE**

**GINNIE**

**GINNIE**

NATURAL RUBBER PREFABRICATED  
INTERNAL FUEL TANK SEALING - TESTING

Developed and Distributed Under  
Contract No. AF33(657)1-7148

**GENERAL DYNAMICS | FORT WORTH**

**Best  
Available  
Copy**



MATERIAL-THIOKOL "ST" RUBBER - PREFABRICATED FILLETS -  
FOR INTEGRAL FUEL TANK SEALING - TESTING OF -

PURPOSE:

The methods of sealing the integral fuel tanks on the B-58 airplane include the use of prefabricated fillets. Although prefabricated fillets have been used extensively in laboratory tests for B-58 fuel tank design and have proved satisfactory, certain of their properties are not known. The purpose of this test request is twofold: (1) To determine the properties of Thiokol "ST" prefabricated fillets per FMS-0034; and (2) to prepare a new procurement specification in order to insure the quality of "ST" Thiokol fillets obtained.

SUMMARY:

All testing was done using prefabricated Thiokol "ST" fillets received from Immel Engineering and Development Co. The tests were run in accordance with the procedures of Convair Specification FMS-0034\* which included tests for specific gravity, linear thermal change, peel strength, flexibility, hardness, tensile strength and elongation, fluid resistance, corrosive action, and thermal flow.

Each of the above listed properties has been obtained on Immel prefabricated fillets and are believed to be representative of what may be expected of Thiokol "ST" fillets. Based on the results of these tests, values have been recommended for a proposed new procurement specification.

\*See Supplemental Pages S-1 through S-8.

MATERIAL-THIOKOL "ST" RUBBER - PREFABRICATED FILLETS -  
 FOR INTEGRAL FUEL TANK SEALING - TESTING OF -

OBJECT:

To determine the properties of Thiokol "ST" prefabricated fillets manufactured by Immel Engineering and Development Company in accordance with proposed Specification FMS-0034.

DESCRIPTION OF MATERIALS:

Although FMS-0034 requests submittal of four different shapes of fillets, all testing was carried out using the Type A or tensile sheet type fillets. The Type A sheets used for adhesion tests were molded by the vendor in molds which had been sand blasted on one side. Sheets used for tensile tests were smooth on both sides.

Type A Fillet Materials

Vendor

Thiokol "ST"

Immel Engineering & Development  
 Company  
 301 South East 14th Street  
 Grand Prairie, Texas

Testing Materials

2024 Clad Aluminum Alloy  
 EC 1373 Sealant

QQ-A-362a  
 Minnesota Mining and Manufactur-  
 ing Company  
 Detroit 2, Michigan

Wipe-Off Naphtha \*

CVAC 14-074360

Phosphoric Acid Cleaner (A-3)\*

FMS-0034

Snythetic Sea Water \*

FMS-0034

Type III Hydrocarbon Test  
 Fluid  
 (70/30: Iso-octane/toluene)

MIL-H-3136

\*See Supplemental Pages S-1 through S-8.

## PROCEDURE:

All specimens were prepared, bonded, and tested according to the procedures stipulated in the proposed Convair Specification FMS-0034.

## RESULTS:

See Table I

## DISCUSSION:

A new concept of integral fuel tank sealing has been incorporated into the design of the B-58 airplane. This new concept makes use of external-type sealing in contrast to the internal sealing that has been used on previous airplanes. It is believed that prefabricated fillets of Thiokol "ST" rubber may be used to advantage in the external seals since they would be denser and stronger than fillets laid down from putty-type (LP-2) sealants. Some testing has been done, during B-58 fuel tank design studies, on the use of Thiokol "ST" prefabricated fillets. However, certain of their properties, such as tensile strength, elongation, etc. are not known. The purpose of this test is to determine the properties of Thiokol "ST" prefabricated fillets, and also to prepare a new procurement specification to insure the quality of fillets obtained from vendors.

The fillets used for testing were all submitted by Immel Engineering and Development Company. These were chosen because they were readily available in sufficient quantity to carry out a

# C O N V A I R

A DIVISION OF GENERAL DYNAMICS CORPORATION  
(FORT WORTH)

PAGE 4  
REPORT NO. FGT-1468  
MODEL B/RB-58  
DATE 24 May 1956

full test program. All tests were run in accordance with procedures set forth in Convair's proposed Specification FMS-0034. However, the property values as stipulated therein were not necessarily used as a basis for passing or failing the material. After each test, the fillet was examined to determine whether or not its condition was such as could be tolerated on the B-58 airplane. If so, a specification value was recommended based on the actual result obtained on that test.

In this manner the properties of Immel prefabricated Thiokol "ST" fillets have been determined. These properties are believed to be representative of what may be expected of "ST" fillets in general. Therefore, the values obtained have been used as the basis for recommending a new procurement specification.

## CONCLUSION:

The physical properties of Immel prefabricated Thiokol "ST" fillets were determined. Results are reported in this report and should serve as a basis for revising Specification FMS-0034.

TABLE I

TEST DATA ON TYPE A PREFABRICATED FILETS OF THIOKOL "ST"

<u>Test</u>	<u>FMS-0034 Requirement</u>	<u>Results Obtained</u>	<u>Recommended Requirements</u>
Specific Gravity	1.55 (max.)	1.45	1.55 (max.)
Linear Thermal Change, in.	$\pm 0.05$	0.01	$\pm 0.05$
Peel Strength, lb./in.			
Before Fuel + Hot Air **	40*	Pass	40*
After Fuel + Hot Air **	40*	Pass	40*
Low Temp. Flexibility (-65°F)			
Before Fuel + Hot Air **	No Cracking, Checking, or Loss of Adhesion	Pass	No Cracking, Checking, or Loss of Adhesion
After Fuel + Hot Air **	No Cracking, Checking, or Loss of Adhesion	Pass	No Cracking, Checking, or Loss of Adhesion
Room Temp. Flexibility			
Before Fuel + Hot Air **	No Cracking, Checking, or Loss of Adhesion	Pass	No Cracking, Checking, or Loss of Adhesion
After Fuel + Hot Air **	No Cracking, Checking, or Loss of Adhesion	Pass	No Cracking, Checking, or Loss of Adhesion
Hardness, Shore A	50 5 (inst.)		
Room Temp. (Control)	45 5 (30 sec.)	66	67 + 7 (inst. only)
After 10 min. at 260°F	Control $\pm 20\%$	59	Control $\pm 30\%$
After 168 hrs. at 260°F	Control $\pm 20\%$	52	Control $\pm 30\%$
Tensile Strength, psi			
As Received	1200 (min.)	825	750 (min.)
After 720 hrs. in Type III	1200 $\pm 20\%$	430	300 (min.)
After 168 hrs. at 260°F	1200 $\pm 20\%$	300	300 (min.)
After Fuel + Hot Air **	1200 $\pm 50\%$	525	750 $\pm 50\%$

TABLE I (Cont'd)

<u>Test</u>	<u>FMS-0034 Requirement</u>	<u>Results Obtained</u>	<u>Recommended Requirement</u>
Elongation, Percent			
As Received	250 (min.)	185	180 (min.)
After 720 hrs. in Type III	250 $\pm 20\%$	125	125 (min.)
After 168 hrs. at 260°F	250 $\pm 20\%$	190	125 (min.)
After Fuel + Hot Air**	250 $\pm 50\%$	160	180 $\pm 50\%$
Corrosive Action	No Pitting, Roughening of Aluminum; No Scaly Oxide in Fluid; No Loss of Adhesion, Softening, Blistering	Pass	No Pitting, Roughening of Aluminum; No Scaly Oxide in Fluid; No Loss of Adhesion, Softening, Blistering
Thermal Flow, In. Elong.			
After 24 hrs. at 140°F	0.03 (max.)	0.00	0.03 (max.)
After 24 hrs. at 200°F	0.03 (max.)	0.00	0.03 (max.)
After 24 hrs. at 260°F	0.03 (max.)	0.00	0.03 (max.)

\*If adhesive failure between fillet and sealant or cohesive failure of fillet occurs, the force required to cause such failure shall not be less than 40 lbs./in.

\*\*The term "Fuel + Hot Air" refers to immersion in MIL-H-3136, Type III fuel for 168 hours at 140°F, followed by exposure to air at 260°F for 72 hours.



## SUPPLEMENTAL INFORMATION

General Dynamics/Fort Worth (Convair) Specification FMS-0034 is referenced in this report for performance requirements, specimen preparation and testing procedures. The referenced requirements and procedures are as follows:

## A. Requirements

## 1. Specific Gravity

The specific gravity of the cured prefabricated fillet material shall not exceed 1.55 when tested in accordance with Para. D.2

## 2. Linear Thermal Change

Fillets shall not expand or contract from the edge of the aluminum panel more than 0.05 inch when tested in accordance with Para. D.3. Fillet shall not buckle during the test.

## 3. Peel Strength

If adhesive failure between fillet and sealant or cohesive failure of the fillet occurs when tested in accordance with Para. D.4, the force required to cause such failures shall not be less than 40 pounds per inch.

## 4. Flexibility

Fillets shall not crack, check or lose adhesion when tested at standard conditions and at  $-65^{\circ}\text{F}$  + 0  $-2^{\circ}\text{F}$  in accordance with Para. D.5.

## 5. Hardness

Initial Shore A Durometer hardness shall be  $50 \pm 5$  (instantaneous) and  $45 \pm 5$  (after 30 seconds). After testing in accordance with Para. D.6, fillet shall not blister nor change more than 20 percent from the initial hardness.

## 6. Tensile Strength and Elongation

Initial properties shall be:

Ultimate Tensile Strength = 1200 psi (min)

Ultimate Elongation = 250 percent (min)

After testing in accordance with Para. D.7, the ultimate tensile strength and elongation shall not change more than 20 percent from the initial values.



## 7. Fluid Resistance

Test per Para. D.8. Hardness, tensile strength and elongation shall not change more than 50 percent from the values recorded before testing.

## 8. Corrosive Action

Test per Para. D.9. Fillets shall not cause pitting or roughening of the aluminum, nor cause scaly oxide deposits in the fluid. Fillets shall not show evidence of loss of adhesion, softening, or blistering.

## 9. Thermal Flow

Test per Para. D.10. Fillet shall not elongate more than 0.03 inch and shall not decrease in length when tested up to 260°F.

## B. Test Conditions

The term "standard conditions" means a temperature of  $75 \pm 5^\circ\text{F}$  and a relative humidity of  $50 \pm 5$  percent.

## C. Test Specimens

The test specimens shall be made from heat molded Thiokol ST elastomer and shall be of the configuration shown in Figure 1 of this supplement.

## D. Test Methods

### 1. Preparation of Test Specimens

#### a. Test Panel Cleaning

Test panels of 2024 clad aluminum (QQ-A-362) shall be cleaned as follows:

- (1) Clean with wipe-off naphtha (Table I) and wipe dry.
- (2) Apply diluted phosphoric acid cleaner (seven parts distilled water to one part cleaner) per Table II.
- (3) Before the cleaner dries, wipe the panel clean with distilled water.
- (4) Dry the panel at 160°F for 30 minutes.

#### b. Fillet Cleaning

Wipe the fillet with phosphoric acid cleaner (diluted as above) and wipe dry with clean cheesecloth.



TABLE I

Wipe-Off Naphtha

<u>Ingredient</u>	<u>Specification</u>	<u>Percent by Weight</u> (+ 1%)
Solvent	P-S-661A	80.0
Aliphatic Petroleum Naphtha	TT-N-95	10.0
Butyl Alcohol	TT-B-846	10.0

TABLE II

Phosphoric Acid  
Cleaner

<u>Ingredient</u>	<u>Specification</u>	<u>Percent by Weight</u> (+ 1%)
Phosphoric Acid	O-P-313 (Class A)	12.0
Citric Acid	USP	16.0
Synthetic Soap	Triton X-100*	8.0
Methyl Ethyl Ketone	TT-M-261	12.0
Distilled Water	Commercial Grade	52.0

\* Manufactured by Rohm and Haas Co.

## c. Application of Sealant

Apply a sealant coating 1/64 inch thick over the bonding area of the cleaned test panels.

## d. Application of Fillets

Press fillets in place, using normal hand pressure. Do not touch fillets with bare hands. Cover the fillets with a smooth coat of sealant. Feather edges of sealant to the test panels. Cure per manufacturer's instructions.

## 2. Specific Gravity

Testing to be performed in accordance with ASTM Standard D-792-50.

## 3. Linear Thermal Change

Bond a 6 1/4 by 5/16 inch strip of fillet material to a 6 by 1 by 0.064 inch aluminum panel. Trim ends of the fillet strip flush with the aluminum panel after the sealant has cured. Place the uncoated side of the panel towards an infra-red heater with a thermocouple wire in the center of the fillet strip at the metal surface. Raise the temperature from room temperature to 300°F at a rate of 3°F per second and maintain the 300°F temperature for 10 minutes. Expansion or contraction shall not exceed



the limits of Para. A.2.

4. Peel Strength

Prepare two test specimens in accordance with Para. D.1. Bond an 8 by 1 inch strip of fillet material to an 8 by 1 by 0.040 inch aluminum panel. Attach the fillet strip so that one end is one inch from the end of the test panel. This will allow a fillet overhang of one inch at the other end of the panel. At the overhand end, the fillet shall be unattached to the panel for one inch. After curing, pull the fillet at right angles to the panel at a jaw separation rate of two inches per minute. The force required to pull the fillet from the panel shall meet the requirements of Para. A. 3.

5. Flexibility

Prepare two test specimens in accordance with Para. D.1. Bond a 4 by 1 inch strip of fillet material to a 6 by 1 by 0.032 inch aluminum panel, leaving one inch of bare metal at each end of the panel. Expose one test panel to a temperature of  $-65^{\circ}\text{F}$   $\pm 0-2^{\circ}\text{F}$ , then test at  $-65^{\circ}\text{F}$  in the flexibility jig shown in Figure 2 of this supplement. Bend the other panel around a  $1/8$  inch mandrel at standard conditions. Tested as outlined above, the fillet material shall meet the requirements of Para. A.4.

6. Hardness

Measure instantaneous and 30-second hardness of the fillet material, using a Shore A Durometer. To assure accurate readings, use as many layers of fillet material as is required to build up to a  $1/4$  inch minimum thickness.

Measure hardness at:

- a. Standard conditions
- b. After 10 minutes exposure to  $260^{\circ}\text{F}$
- c. After 168 hours exposure to  $260^{\circ}\text{F}$

When tested under these conditions, the fillet material shall meet the requirements of Para. A.5.

7. Tensile Strength and Elongation

Cut nine tensile coupons from the fillet material, using the die and procedure in ASTM Standard D-412-51T. The tensile coupons shall be tested in a tensile machine with a jaw separation rate of 2 inches per minute. Three of the tensile coupons shall be tested under each of the following conditions:



- a. At standard conditions
- b. At standard conditions after immersion for 720 hours at 140°F in fluid conforming to MIL-H-3136, Type III
- c. At standard conditions after exposure to 260°F for 168 hours.

Tested under these conditions, the fillet material shall meet the requirements of Para. A.6.

## 8. Fluid Resistance

Immerse fillet material samples, as required for the following tests, in test fluid conforming to MIL-H-3136, Type III, for 168 hours, expose to air at 260°F for 72 hours, and then proceed with the following tests:

### a. Peel Strength

Test per Para. D.4. Specimens shall meet the requirements of Para. A.3.

### b. Hardness

Test per Para. D.6. Specimens shall meet the requirements of Para. A.5.

### c. Tensile Strength and Elongation

Test per Para. D.7. Specimens shall meet the requirements of Para. A.6.

### d. Flexibility

Test per Para. D.5. Specimens shall meet the requirements of Para. A.4.

## 9. Corrosive Action

Immerse a peel strength test specimen vertically in a covered glass vessel containing a two-layer liquid consisting of synthetic sea water (Table III) and test fluid conforming to MIL-H-3136, Type III, so that two inches of the specimen is in contact with each liquid and two inches is exposed to the air-vapor mixture. Maintain the specimen in the two-layer liquid at a temperature of 140°F for 20 days. Remove from the liquid and immediately examine the specimen for compliance with the requirements of Para. A.8.

TABLE III  
SYNTHETIC SEA WATER

INGREDIENT	WEIGHT GRAMS PER LITER OF DISTILLED WATER
Sodium Chloride (NaCl)	25.0
Magnesium Chloride ( $MgCl_2 \cdot 6H_2O$ )	11.0
Calcium Chloride ( $CaCl_2 \cdot 2H_2O$ )	1.0
Anhydrous Sodium Sulfate ( $Na_2SO_4$ )	4.0

## 10. Thermal Flow

Benchmark the throats of six tensile strength specimens. Mount the specimens vertically in pairs with one end clamped to a smooth bar. Expose the specimens to the following temperatures, two to each temperature for 24 hours:

- a.  $140^{\circ}F$
- b.  $200^{\circ}F$
- c.  $260^{\circ}F$

The specimens shall then meet the requirements of Para. A.9.

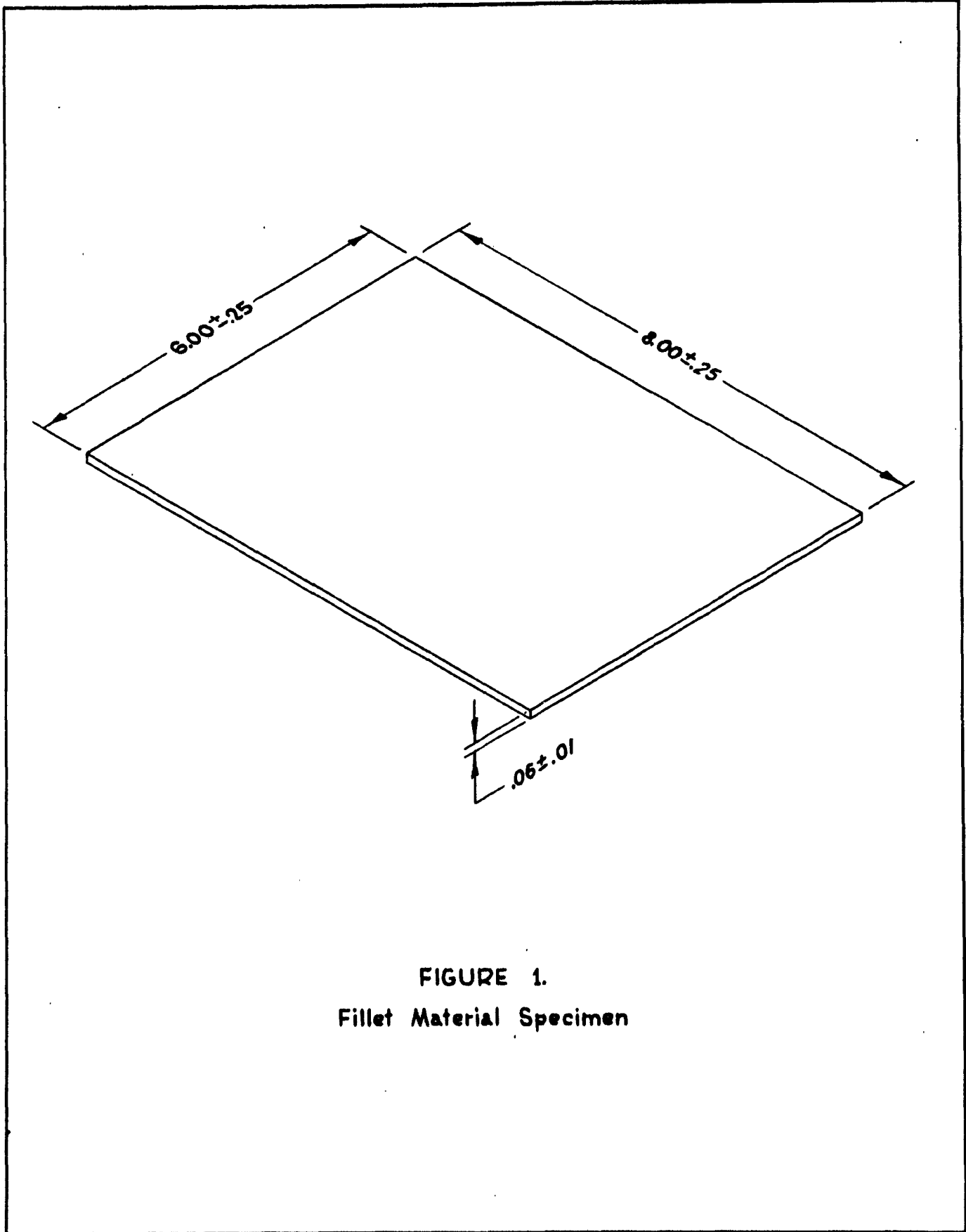
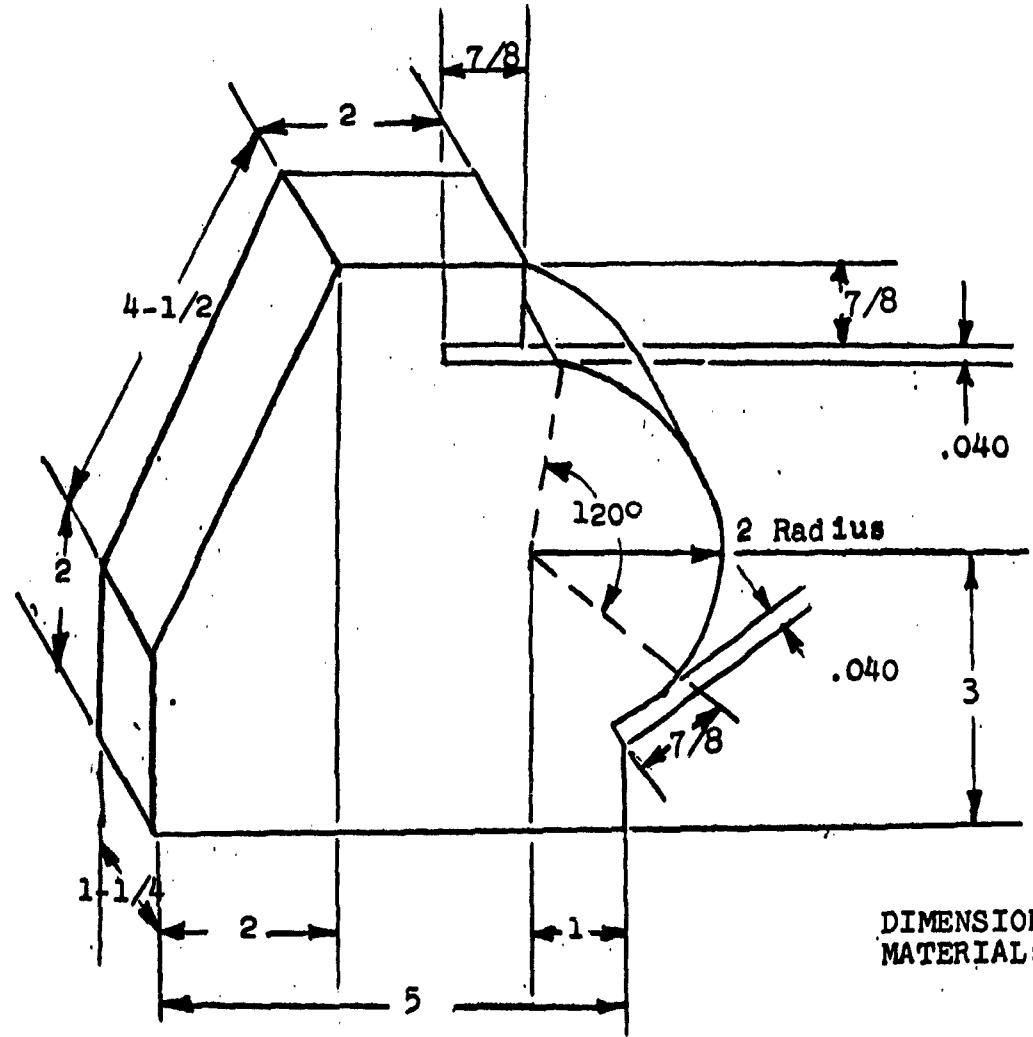

FIGURE 1.  
Fillet Material Specimen



DIMENSIONS IN INCHES  
MATERIAL: MAPLE WOOD

LOW TEMPERATURE FLEXIBILITY TEST JIG

FIGURE 2