

UNCLASSIFIED

---

---

AD 286 783

*Reproduced  
by the*

ARMED SERVICES TECHNICAL INFORMATION AGENCY  
ARLINGTON HALL STATION  
ARLINGTON 12, VIRGINIA



---

---

UNCLASSIFIED

**Best  
Available  
Copy**

NOTICE: When government or other drawings, specifications or other data are used for any purpose other than in connection with a definitely related government procurement operation, the U. S. Government thereby incurs no responsibility, nor any obligation whatsoever; and the fact that the Government may have formulated, furnished, or in any way supplied the said drawings, specifications, or other data is not to be regarded by implication or otherwise as in any manner licensing the holder or any other person or corporation, or conveying any rights or permission to manufacture, use or sell any patented invention that may in any way be related thereto.

65-1-2

28622

RAOC-TDR-62-301

19 October 1962

# FEASIBILITY STUDY OF A HIGH PERFORMANCE ANTENNA TEST RANGE (U)

by

A. J. Campanella, C. F. Douds, R. E. Wolfe

HRB-Singer, Inc.  
State College, Pennsylvania

289.4-F

AF 30(602)-2445

Applied Research Branch  
EM Vulnerability Laboratory

Prepared  
for  
Rome Air Development Center  
Air Force Systems Command  
United States Air Force

Griffiss Air Force Base  
New York

ASTIA  
RECORDED  
OCT 27 1962

ANTENNA TEST RANGE  
STATE COLLEGE, PA

FEASIBILITY STUDY OF A HIGH PERFORMANCE  
ANTENNA TEST RANGE (U)

by

A. J. Campanella, C. F. Douds, R. E. Wolfe

HRB-Singer, Inc.  
State College, Pennsylvania

289.4-F

HRB Project  
Task 4

AF 30(602)-2445

Applied Research Branch  
EM Vulnerability Laboratory

Prepared  
for  
Rome Air Development Center  
Air Force Systems Command  
United States Air Force

Griffiss Air Force Base  
New York

Copy No. 25 of 72 Copies

## ABSTRACT

A high performance antenna range is needed to be able to provide adequate data about new and old systems for the RFI Compatibility Program of the DOD. The major problems in the design of a range are to provide adequate spacing for far field measurements and to provide sufficiently uniform illumination of the antenna under test. Analytical treatment is given to the Fraunhofer equation for antenna spacing, the deliberate use of the range surface reflection, and the use of a ramped surface and fences to avoid undesired scattering above L-band. Receiver gating and FM techniques are analyzed for eliminating scattering from beyond the range. A 6000-ft. range with a movable transmitter unit and adjustable height transmitter antenna is recommended for installation on the RADC Verona, New York, test site.

## FOREWORD

The formulation of the concepts and development of the details of this report. has been greatly aided by the contributions of the following consultants from The Pennsylvania State University: Dr. J. R. Mentzer, Dr. A. J. Ferraro, and Dr. C. Volz; and members of the HRB staff: J. C. Cook, R. H. Hunter, R. S. Norris, W. Radzelovage, and C. L. Welch.

The study was sponsored by Rome Air Development Center (AFSC), contract no. AF30(602)-2445, under project no. 4540, Task no. 454001. Technical monitoring was under the cognizance of Mr. Louis F. Moses and 1st. Lt. Dean L. Baerwald of the EM Vulnerability Laboratory.

## TABLE OF CONTENTS

	Page
FOREWORD	v
ABSTRACT	iii
LIST OF ILLUSTRATIONS	xi
LIST OF TABLES	xv
CHAPTER	
I FEASIBILITY OF A HIGH-PERFORMANCE ANTENNA TEST RANGE	1
A. Origin and Organization of Work	
B. Statement of the Problem	1
C. Antenna Measurements Desired	5
D. Sources and Control of Measurement Errors	6
E. Range Design and Error Reduction Techniques	13
F. Recommendations for an Antenna Test Range on the Verona Test Site	34
G. Anticipated Performance Capabilities	36
H. Recommendations for Further Development	37
II NULL DEPTH MEASUREMENT LIMITATIONS	39
A. Pattern Measurements	39
B. Analysis of Null Depth Measurement	40
III THE GROUND REFLECTION TEST RANGE	61
A. The Technique	61
B. Calculation of the Vertical Field	63
C. Maximum Aperture	73
D. The Coefficient of Reflection	74
E. An Alternative Derivation	77
F. Range Design Constraints	78

TABLES OF CONTENTS (Cont'd)

		Page
IV	SCATTERING AND UNCONTROLLED REFLECTION	81
	A. Site Errors	81
	B. Object Scattering	84
	C. Terrain Scattering	89
V	SIGNAL PROCESSING TECHNIQUES	93
	A. Time Domain Signal Processing	93
	B. Frequency Domain Signal Processing	96
	C. Signal Analysis	100
	D. Error and the Signal Processing Filter	106
	E. Signal Requirements	107
	F. Comparison of Systems	108
VI	RANGE SURFACE REQUIREMENTS	113
	A. The Rayleigh Criterion for Flatness	113
	B. Grading Tolerance	113
	C. Analysis of Elliptical Fresnel Zones	114
VII	THE RAMPED RANGE	123
	A. Ramped Range Diffraction	123
	B. Conclusions	131
VIII	BLOCKING FENCES	133
	A. Wave Derivation	133
	B. Total Field at Receiver	139
	C. Conclusions	142
IX	ATMOSPHERIC PHENOMENA	143
	A. Introduction	143
	B. Analysis of Mirages	143

TABLE OF CONTENTS (Cont'd)

	Page
X TRANSMITTER POWER REQUIREMENTS	147
A. Factors Involved	147
B. Path Loss	147
C. Power Requirements	151
XI THE TRANSMITTER UNIT AND RANGE SURFACE	155
A. Transmitter Range and Height	155
B. Antenna Considerations	161
C. RF Units	162
D. Tower Structure and Range Surface	163
E. Remote Operation and Other Factors	165
REFERENCES	167
BIBLIOGRAPHY	169

## LIST OF ILLUSTRATIONS

Figure		Page
1	Aerial Photo of Verona, N. Y. Site	3
2.	Map of Verona Site	4
3.	Reflection or Scattering Error	10
4.	Error Control Zones	14
5.	The Reflection Range	16
6	Antenna Enclosures	19
7.	Recommended Antenna Test Building	23
8.	Open Front for Work Tests and Adjustments	24
9.	Ramped Range	27
10.	Ray Blocking Fence	27
11.	Range Placement	30
12.	Variable Four-Station Range	31
13.	Maximum Receiver Antenna Aperture	31
14	Phase Variation Across Plane	41
15.	Maximum Phase Variation (Point Source)	41
16.	Range Variation with Aperture Size	43
17.	Hypothetical Antenna Pattern	45
18.	Theoretical Patterns of Circular and Square Apertures	47
19.	Maximum Phase Variation (Line Source)	49
20.	Geometry of Null Depth Analysis	51
21.	Null Depth Factor	58
22.	Representation of Ground-Reflection Range	62
23.	Total Amplitude	64
24.	Reflection Geometry	64

LIST OF ILLUSTRATIONS (Cont'd)

		Page
25.	Variations in Amplitude of Illumination	68
26.	Variations in Phase of Illumination	70
27.	Transmitter Antenna Heights	72
28.	Reflection Coefficient	75
29.	Scatter Level Error	83
30.	Object Scattering Geometry	85
31.	Error Control Zones	91
32.	Sample Scattered Wave Geometry	94
33.	Gating Block Diagram	95
34.	Timing Diagram for the Pulsed Signal Method	97
35.	FM Sweep Wave Form and Receiver Signals	101
36.	Datum Signal Characteristics	103
37.	Frequency Stable FM Sweep System	109
38.	Reflection Fresnel Zones	115
39.	Ellipsoids Describing Fresnel Zones	115
40.	Ellipsoid Determined by Fixed Path-Length Difference	116
41.	Ramp Ray Diagram	124
42.	Classical Edge Diffraction Equivalent Problem	125
43.	Shadow Wave Amplitude	129
44.	Fence Configuration	134
45.	Fence Waves	135
46.	Frequency Variation of Fence Diffracted Waves	140
47.	Vector Representation of the Addition of Fields	141
48.	Sylvania Roof Top Range Fences	141
49.	Mirage Conditions	145

LIST OF ILLUSTRATIONS (Cont'd)

	Page
50. Gain Ratio Factor B	152
51. Variable Four-Station Range	157
52. Maximum Receiver Antenna Aperture	158
53. Maximum Receiver Aperture for 20-ft. Antenna Height	159
54. Range with Two Fixed Stations	150

LIST OF TABLES

TABLE		Page
I.	Dielectric Constants	75
II.	Effective Aperture and Linear Dimensions	152

CHAPTER I  
FEASIBILITY OF A HIGH PERFORMANCE  
ANTENNA TEST RANGE

A. ORIGIN AND ORGANIZATION OF WORK

Increasing emphasis upon the control of radio frequency interference and requirements for ever greater performance from all types of electronic systems have resulted in the need for an antenna test range of superior quality. In order to control as many variable parameters as possible a completely enclosed range, an anechoic chamber, at first appears highly desirable. However, an intensive study\* of this possibility has unfortunately shown it to be impractical. It then becomes necessary to consider the feasibility of a high performance outdoor antenna test range. This report, prepared under Task Order 4 of AF 30(602)-2445, is concerned with that problem.

This first chapter briefly summarizes the problems, the methods of handling the problems, and presents the conclusions and recommendations. The detailed analysis is presented in the remainder of the report. The construction of a high performance range is considered to be feasible. However, because of the obstinate nature of physical laws not yielding to human desires, not all of the requirements can be met all the time.

B. STATEMENT OF THE PROBLEM

This report is a feasibility study for an antenna test site to be installed by Rome Air Development Center at its Verona, N. Y. test site. A year-round capability to test antennas up to a 60-foot maximum dimension is to be provided in the frequency range 40 Mc to 40 Gc. Testing is to be done in the far field of the antenna pattern, with a maximum range length limitation of 4000 to 7000 feet. A dynamic range of 60 db must be provided in the instrumentation. Polarization information must be obtained. Concern for minimizing RFI effects in

---

\*HRB-Singer, Inc. Radio Frequency Anechoic Laboratory Design Study by R. E. Wolfe, et al; Nov. 1961; HRB Report #289.1-F; RADC-TDR-62-8.

\*HRB-Singer, Inc. Evaluation of a Hemispherical Anechoic Chamber by E. H. Wintermute, et al; April 1961; HRB Report #252.1-F; RADC-TR-61-126

other systems requires that the antennas be tested over a wide range of non-design frequencies in addition to the usual measurements at the designed operational points.

Two separate enclosures are to be provided separated by a flat or ramped surface. The receiver building would house the antenna under test and provide year-round operation. The transmitter unit is to be mobile along the range length. The problems concerned in the optimum configuration of the intervening ground and the test signal are to be investigated.

The available real estate is shown in Figures 1 and 2. The range placement is further limited by the existing structures which influence the configuration, not only because the range cannot go through them, but also because they will act as reflectors or scattering sources to the test signal and as sources of spurious signals from the radiating equipment associated with them.

The initial statement of work called for a study of the use of a radome over the antenna under test. This was intended to provide an all-weather capability. The initial investigation showed rather quickly that a satisfactory radome could not be provided within the foreseeable state of the art that would allow the other requirements to be met. The implication of an all-weather capability was then re-interpreted as a year-round capability. This is satisfactory for the following reasons.

It is characteristic of antenna testing that much more time is spent on mechanical work on the antenna--erection, adjustment, modification, and disassembly--than is spent making the measurements themselves. It is also true that valid measurements are not likely to be obtained when there is severe precipitation. Therefore the year-round operational requirement means that it should be possible to do mechanical work on the antenna under test at any time, but it is considered feasible to delay measurements for a few days if required by the weather.

Receiving instrumentation, within the state of the art, can provide adequate measurement accuracy at the antenna terminals. The problem in the design of an antenna test range is to insure that only the desired signal at the desired amplitude and phase is recorded by the instrumentation. Reflections from the range surface and from surrounding objects, atmospheric effects, and radiations from other sources must be considered in the layout of the range, design of the test

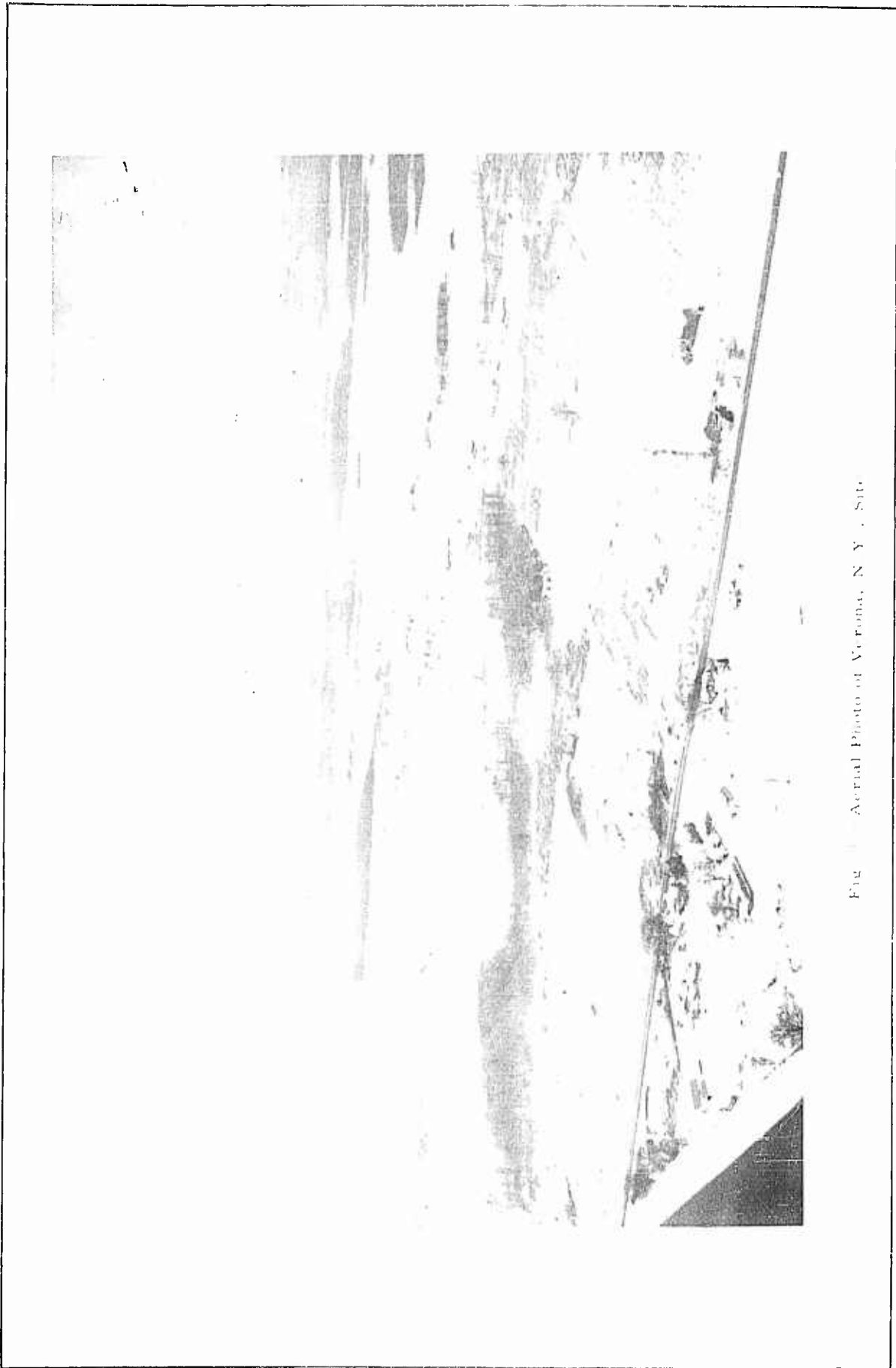

Fig. 1—Aerial Photo of Verona, N. Y., Site

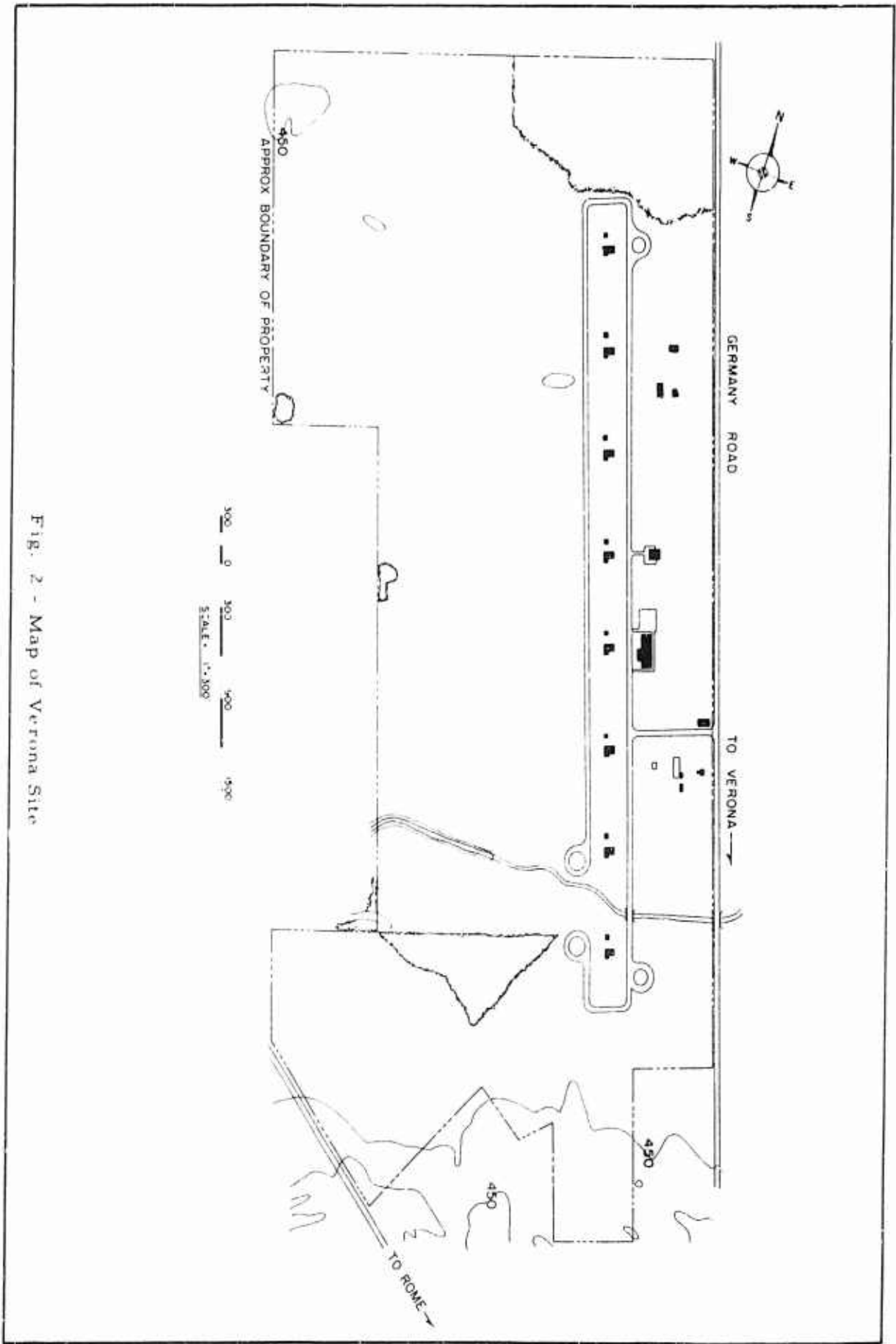

Fig. 2 - Map of Verona Site

antenna structure, and implementation of the receiving system

The main problems to be considered are then:

1. Layout of the test range and the treatment of the range surface for minimization of undesired reflection and scattering effects.
2. The configuration of the main antenna test building.
3. Provision for changes in range length
4. Radio frequency requirements test signal receivers, transmitters, antennas and recording equipment.

### C ANTENNA MEASUREMENTS DESIRED

It is possible to describe the radiation characteristics of an antenna in terms of a number of quantities. These include aperture field, current distribution, radiation pattern, absolute gain, polarization, and efficiency. When a radome is part of the antenna design the boresight error, scatter lobes and radome losses must also be included. The aperture field and current distribution are primarily of use to the antenna designer. The other parameters are of concern in systems evaluation. The gain, polarization and antenna pattern, including particularly null depth, are of major importance when considering RFI between systems.

Most often it is desired to determine the far field pattern of an antenna. In theory this means that when making the pattern measurement the radiation illuminating the antenna under test should be a uniform plane in both amplitude and phase. In practice some variation is allowed so that the spacing between the antenna being tested and the radiation source may be finite.

An antenna pattern in general is made up of a main lobe and side and back lobes of reduced amplitude. High angular resolution antennas may have a split or multiple main lobe. Splitting of the main lobe and severe distortions of the remainder of the pattern may also occur when antennas are tested at nondesign frequencies, such as harmonics or at spurious outputs of the transmitter intended to operate with them. Experimental work to date has indicated that the gain of antennas remains essentially constant up to eighth or ninth harmonic of their design frequency.\*

\*O. M. Salati, "Recent Developments in RF Interference," IRE Trans. on RFI, May 1962, pp 24-33.

In RFI work detailed information about side and back lobes is particularly important to obtain so that the state of the art in antenna design may be advanced. The side and back lobe radiation serves no useful purpose and is a potent source of interference in high power systems. Null depth information is also very important for antennas that will be operating at a fixed azimuth so that other systems, particularly ones that will be in the immediate vicinity, can be situated for minimum interference.

An antenna pattern is obtained by rotating the antenna under test while recording the level of the received signal. The gain of the main beam of an antenna is obtained by using a calibrated source antenna and calibrated receiving system. The antenna pattern can then be interpreted in absolute terms. Polarization data is usually obtained by taking two patterns one with the source antenna horizontally polarized and one with it rotated to vertical polarization. Other techniques are also available.

The accuracy of the measurements is dependent not only upon the instrumentation but very significantly upon the conditions under which the measurements are made. The antenna test range can have a very strong effect upon the validity of the measurements, and thereby provides the major problem with which this report is concerned. At the present time the state of the art in antenna measurements is limited by the sites available rather than by the instrumentation.

#### D. SOURCES AND CONTROL OF MEASUREMENT ERRORS

##### 1. Sources of Error

There are three major sources of error in making antenna measurements: apparent errors arising from not meeting the far field criterion; errors arising from real or apparent spurious signal sources, and measurement equipment errors. The design of the antenna range site is primarily concerned with the first two factors. The nature of the test signal, the receiving system, and recording equipment will affect the third factor.

The far field criterion implies that the radiation impinging upon the system antenna under test will be essentially a plane wave. Whatever deviations that exist must be small enough so that they cannot affect the desired measurement.

Deviations from ideal illumination take the form of nonuniformities in phase and amplitude illumination across the aperture plane, both in the horizontal and vertical directions. Illumination variations may also arise from the test signal energy traveling to the system antenna by other than a direct path. Such paths exist because of reflections from the earth's surface, surrounding structures, scattering from natural objects, man-made objects, and atmospheric instability.

## 2. Fresnel and Fraunhofer Patterns

If a small measurement probe is placed very close to an antenna and a pattern record is made, the curve traced out will be very nearly omnidirectional, even for high gain antennas. At successively greater distances from the antenna the main beam and side lobes become more clearly apparent with each increase in distance. Finally, as this process is repeated, the peaks of the main beam and side lobes maintain their same relative magnitudes and only the nulls between them change, becoming deeper as the distance is increased.

At very short ranges the pattern is predominantly affected by the induction field of the antenna. However, this diminishes very rapidly with distance. The variations in the patterns observed may then be thought of as being caused by the difference in angle and path length from the point of observation to the various radiating points of the antenna. The region in which these angular variations is relatively large is called the Fresnel zone. The region in which the variations are small is called the Fraunhofer zone. It is clear that as the measurement probe is uniformly moved away from the antenna, the angle from the probe to any given point on the antenna changes uniformly. When is an angle large, and when is it small? It is a matter of arbitrary definition, and accordingly the distinction between the Fresnel and Fraunhofer zones is a matter of definition.

To increase the gain of an antenna at a given frequency requires that more of its energy must be focused in a given direction. This requires that the size of the antenna be increased. Since the distinction between the two zones involves the angle subtended by the antenna from the point of observation, a bigger antenna (a higher gain antenna) will mean that we must move farther away if we want to measure it only from the Fraunhofer zone.

Although one speaks of obtaining "far field" antenna patterns, what is customarily meant is that the pattern is measured in the Fraunhofer zone. The

criterion for obtaining Fraunhofer patterns with a minimum spacing,  $R_{\min}$ , between the antenna under test and the observing or source antenna is:

$$R_{\min} = \frac{2D^2}{\lambda}$$

where  $D$  is the maximum dimension of the antenna under test and  $\lambda$  is the radio frequency wavelength. This assumes that the measurement antenna is small compared to the size of the antenna under test. This equation then means physically that the phase variation of the illumination across the aperture of the antenna under test is no greater than  $\lambda/16$  or  $22.5^\circ$ . The derivation also implies that the amplitude of the illumination is uniform and hence the phase varies uniformly.

Now if one states that a far field antenna pattern is to be obtained to a null depth of 60 db, the criterion stated above is inadequate, for it is shown in Chapter II that patterns measured at a spacing given by the Fraunhofer equation are far field patterns in the first null down to a level of only 23 db below the peak value of the main beam.

However, if it is stated that the far field antenna pattern is to be obtained and that the relative null depths are to be obtained over a 60 db dynamic range, the Fraunhofer criterion is satisfactory, for this means that the pattern does not have to be obtained in the far field sense over the full dynamic range.

To obtain 60 db dynamic range far field patterns requires that the spacing be

$$R_{\min} = \frac{2 a D^2}{\lambda} \quad \text{where } a = 90$$

For large antennas operating in the microwave frequencies common for radars, distances on the order of tens to hundreds of miles are involved. This is clearly impractical and of little use for most earth-bound systems--space and missile problems excepted.

There are two important points to be noted. First, any antenna pattern is valid for the distance at which it was obtained (provided, of course, that the test procedure provided proper control of all the other variables). Whether or

not this pattern is useful depends upon conditions external to the test itself. It depends upon the use to which the pattern is to be put. Second, the manner of stating the requirements is vitally important. They must be stated in terms of the use to be made of the measurement.

It is seen that "error" arising from not meeting the far field criterion is not an error at all. There may be a discrepancy between the pattern obtained and the pattern desired, but there is not an error in the analytical sense of the word.

The above discussion should not be interpreted to mean that antenna patterns cannot be obtained in the far field sense below the 23 db level (for  $a = 1$ ). The analysis performed to date has only considered the null between the main beam and the first side lobe. When one considers lobes whose peaks at some point on the pattern are, say, 30 db below the main beam the null between them may be traced accurately in the far field sense to some level below peak value of these lobes. This may be 20 db or only 5 db. Further analysis is required.

### 3. Reflection and Scattering

Errors in antenna pattern measurements will arise because of energy traveling from the source antenna to the antenna under test by other than the desired path. Energy may be reflected or scattered, in either case that part of it which is picked up by the receiving antenna will affect the signal level in the measurement circuits, causing errors in the indicated pattern.

The problem becomes most serious when a null in the antenna pattern is directed toward the source and the main beam is directed towards a strong reflection or scattering object that is illuminated by a strong side lobe of the source antenna as indicated in Figure 3. Buildings, trees, automobiles, other antennas, fence rows, and so forth will act as spurious sources of energy. When the main beam is directed towards such objects, the gain of the beam magnifies the effective illumination of these objects by the side lobes of the source antenna. At other orientations of the receiving antenna the energy contributed by a given spurious path will be reduced by the change in the antenna gain along that path. The error for this new orientation will also be affected by the change in the antenna gain along the range axis. The greater the gain along the range axis and the smaller the gain in the directions to the spurious sources, the smaller the

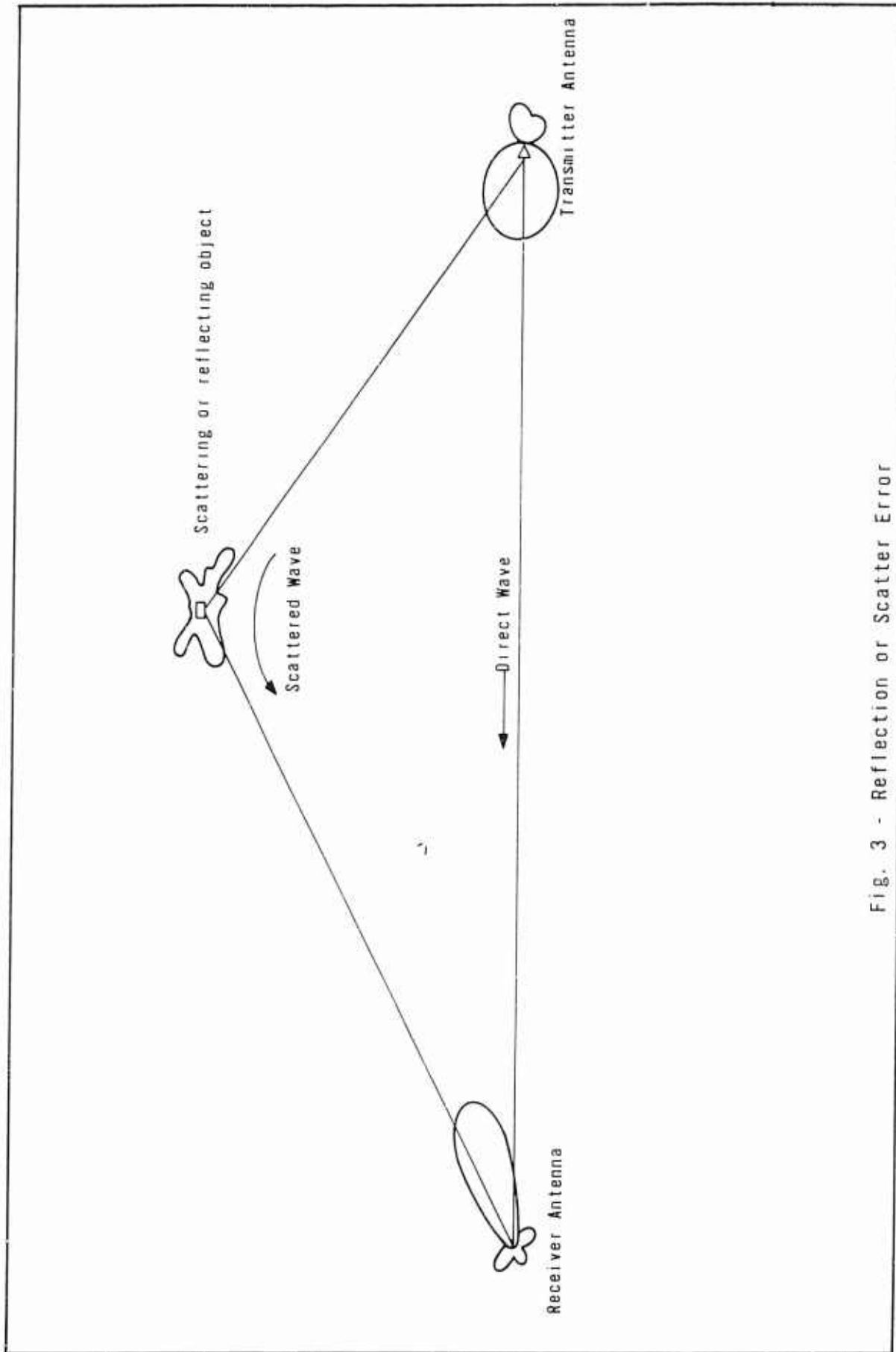

Fig. 3 - Reflection or Scatter Error

error will be. However, the range must be designed considering the worst case.

The matter of the surface of the earth is of some importance, for it constitutes a dielectric reflector that must be contended with in any antenna test range. Off the axis of the range it becomes a diffuse scattering source affecting the pattern in the manner just considered but over all azimuths. On the axis of the range the problem is somewhat different. Here we need not consider what part of the antenna pattern is directed down the range. However, the source antenna will illuminate the ground over a considerable distance and an appreciable portion of this energy will enter the receiving antenna upon reflection. The magnitude and phase of the reflected wave will depend upon the angle of incidence, the area and location of the illuminated region or regions, the reflectivity of the ground, and the polarization of the incident wave. The reflectivity will be determined by the surface material, moisture content of the ground, source frequency, polarization, and angle of incidence.

That the surface reflected wave can be used to advantage in antenna testing will be considered later.

#### 4. Atmospheric Effects and Weather

Atmospheric variations in the propagation path between the source antenna and the antenna under test can cause variations in the wave front. Such instabilities will introduce noise-like disturbances in the antenna pattern which can be particularly severe in measuring the main beam of very high gain antennas. These variations are caused by thermal gradients in the atmosphere which are dependent upon the amount of sunlight, effective sky temperature (at night), winds, clouds, and the nature of the range surface. Little can be done to control such atmospheric variables. If the nature of the testing in progress requires a very stable atmosphere, it is usually necessary to work during the early morning hours when the atmosphere is most stable. Also during this time the moisture content of the range surface, and hence its reflectivity, usually stabilizes for several hours.

An antenna range located in a northern climate must also contend with snow. If it were not for the fact that snow drifts, it would be of little importance except for some possible difficulties with vertical polarization measurements. However, drifted snow will cause variations in the groundplane which will give rise

to undesired reflections and scattering of the RF energy. It will also obscure the effects of a ramp and fences. Plowing is not a satisfactory solution for high accuracy tests since, although it might clear the prepared range surface, the banks remaining will act as off-axis scattering lines. The best solution to the problem is to simply avoid snow. However, various compromise solutions can be worked out, all of which will involve some decrease in the accuracy of measurements or significant increase in expenditures for a large range.

#### 5. Error Control Zones

Almost every point that will have to be considered in the construction of an antenna test range will also have to be considered from the standpoint of its effects upon the accuracy of the range. The receiving system and source antennas obviously require very careful consideration. Such factors as the location of access roads, parking lots, and landscaping (assuredly someone will want a flagpole) will also have a significant influence upon range accuracy. If the efficiency of use and utilization factors are also considered--and these can influence the range accuracy through their effects upon human behavior--then the internal arrangements of the buildings must also be considered. However, for the present only the major sources of error will be considered, but from a standpoint that more detailed design can proceed later. The most serious limitation upon range performance is the production of the desired amplitude and phase uniformity of the radiation presented to the antenna under test. Perturbations in the illumination will arise from scattering and reflection from the range surface, the area surrounding the range, from objects on the surface. The degree to which these can be controlled depends upon a number of factors, most of which are ultimately related to distance from the transmitter to the receiver via the point or object in question.

On this basis it is convenient to consider three zones on the site as indicated in Figure 4. The inner region, Zone I, is the prepared surface of the range proper. Its function is to provide a desired specular reflection (as will be explained in the next section) and to minimize other undesired specular reflections and scattering effects. Its surface will have to be prepared to very close tolerances and be well maintained. A ramped shape will be utilized to reduce some of the undesired reflections and at the same time ease grading tolerances. Ray blocking fences will also be used at the higher frequencies where the grading

tolerances become untenable.

Skipping Zone II for the moment, Zone III is the region where it is not practical or possible to control the real estate and the objects on it. No restrictions are placed upon it. Undesirable effects originating here will be removed by processing the transmitted and received signal.

Zone II is a buffer zone where the terrain is maintained clear of large scattering objects and must be under the control of the antenna test range facility. Practical signal processing methods cannot remove the diffuse scattering to be expected from this area, and so it will ultimately determine the accuracy of the range. The reason for a distinction between Zone I and Zone II is purely a matter of economics. Zone I should be as large as practical.

Since signal processing techniques will operate on the difference in time of arrival of the direct ray traveling down the axis of the range and the reflected or scattered signals arriving from Zone III, the boundary shape between II and III is elliptical. However, the boundary location is admittedly fuzzy, for its sharpness depends on the resolution capabilities of the signal processing equipment, e. g., the gate rise time in a pulsed system and filter cutoff slope in an FM system. It is not desirable to make either of these parameters sharp for they will then affect the accuracy when measuring frequency sensitive antennas

## E. RANGE DESIGN AND ERROR REDUCTION TECHNIQUES

### 1. The Reflection Range

The shape of the range surface will have a significant effect upon the range operation. The range surface will absorb, reflect, and scatter energy in various ways. For a given material and shape the distribution of the amount of energy affected by these mechanisms will be a function of frequency. In general, as the frequency increases the amount of scattering will increase. There are two diametrically opposite approaches to handling this problem. One is to try to minimize the amount of energy that can be received by the antennas under test. The other is to make use of the energy from the ground by careful arrangement of the transmitter and receiver antennas.

The latter approach ideally has the ground a planar dielectric mirror from one antenna to the other. Energy is reflected from this surface out of phase

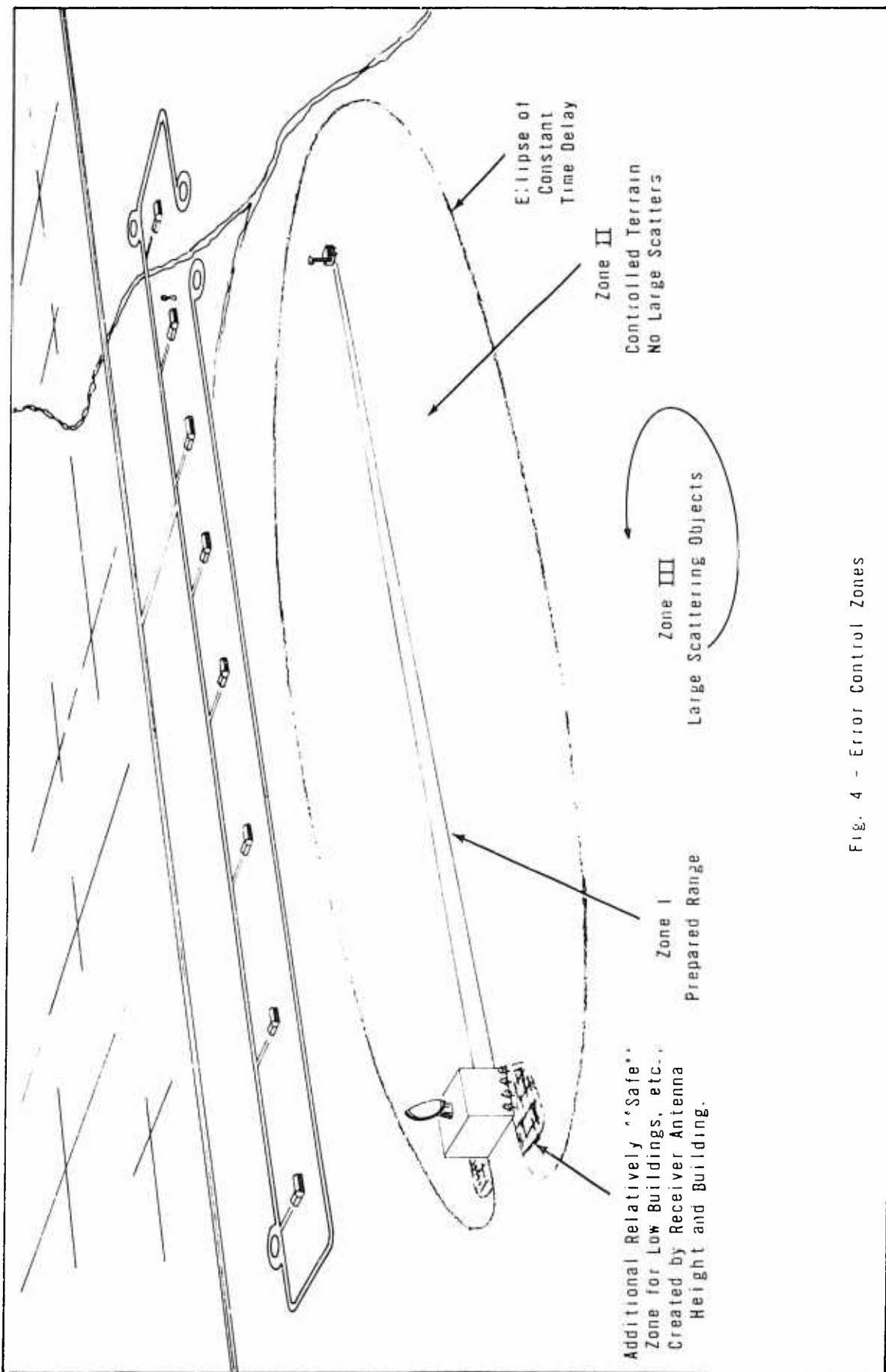

Fig. 4 - Error Control Zones

with the incident wave. At the receiver these two waves add or subtract as the elevation is increased, starting with a minimum at ground level as indicated in Figure 5

Fortunately, when a RF beam strikes the ground at grazing angles most common materials (nonmetallic) act as a dielectric mirror. Of course, they must be sufficiently flat or the angle will not be grazing. As seen from the receiving antenna, the energy coming from the point of specular reflection on the ground appears to be coming from an image of the transmitter located the same distance beneath the ground as the transmitter is above it. The magnitude of this image is determined by the reflection coefficient. If the coefficient is -1, as it would be for dry ground and very small angles, then the image has the same magnitude as, but is of opposite phase to, the real source. The combination of the direct and reflected rays produces an interference pattern with a null at ground level and at successive points above. The locations of these nulls and the intervening maxima are determined by the heights of the two antennas as well as the distance between them. Normally the antenna under test is located on a maximum, although it need not necessarily be. The height of the receiver,  $H_R$ , and the height of the transmitter,  $H_T$ , required for this condition is

$$4 H_R H_T = \lambda R$$

where  $R$  is the distance between the antennas. With  $H_R$  and  $\lambda$  fixed, either  $H_T$  or  $R$  or both can be varied to produce the desired illumination.

It is apparent that this amplitude distribution creates a variation in the illumination across the antenna under test. If a variation of  $\pm 1/4$  db is allowed, then the height required for a given aperture size,  $D$  (vertical dimension), is

$$H_R = 2.4 D.$$

For a dish whose aperture is 60 feet in vertical dimension this means that the height must be 143 ft. Fortunately, some compromise is possible with this since the same illumination tolerance can be maintained when the height is decreased somewhat. For the purposes of the range under consideration, 120 ft. is considered to be minimum height for a 60 ft. antenna.

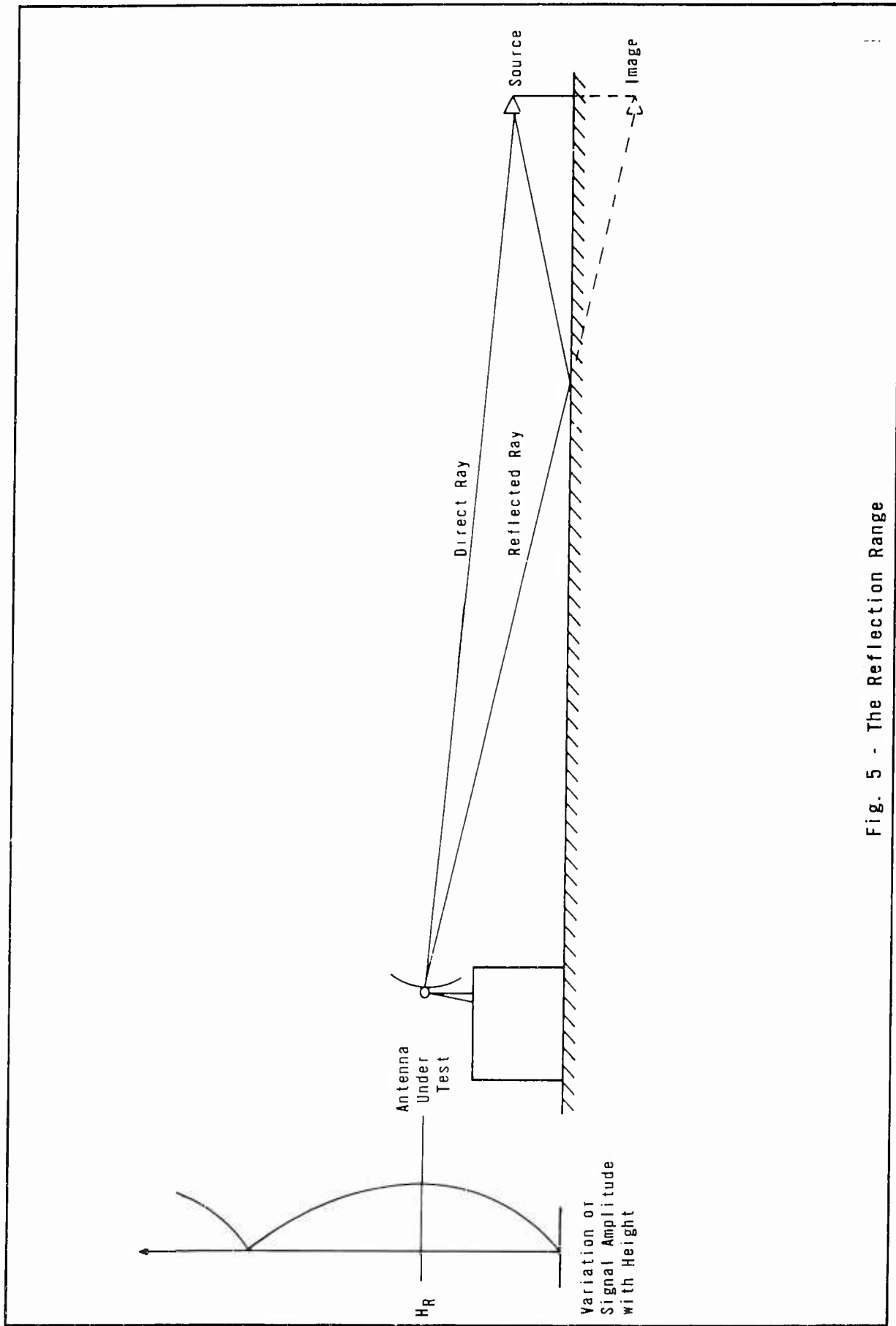

Fig. 5 - The Reflection Range

## 2. Receiving System Structure

The design of receiving system facility is one of the major mechanical problems in the design of the range. The utility of the range will be determined to a great extent by this structure. It must provide a location and facilities for erecting antennas up to 60 feet in diameter, shops for mechanical and electronic modifications, and a housing for the receiving and recording system. Most important, it must not interfere with the conduct of the tests. It should be possible to work on antennas throughout the year, although it is considered feasible to restrict antenna testing during inclement weather.

The major design problem is created by the requirement that the antenna be raised to a considerable elevation and that it have a clear field of view through 360° azimuth during tests, yet that it be possible to work on the antenna in all weather conditions. This requires that the antenna be enclosed, except during tests when it must be in the clear.

It is possible to consider the use of radomes so that the antenna may be tested from an enclosed location. However, even when an antenna system is to be used only in a limited frequency range, the antenna and radome must be designed together in order that the radome not affect the antenna pattern. No radome material and structural technique exists that will allow the range to be operated over its intended frequency range of 40 Mc to 40 Gc while producing a pattern accurate over a 60 db dynamic range.

Several techniques that may be considered are presented in Figure 6. The most straightforward solution to the problem appears to be a simple rectangular building sufficiently large to allow the maximum size antenna to be erected inside and then elevated straight up to the roof top level. Such a structure is shown in Figure 7. The size of the largest antennas to be put up ensures that the rooftop height will be adequate for providing a clear view. Although the configuration of the elevator may be out of the ordinary, it should not be unusually difficult to engineer. Of course, the roof would have to contain a fairly large rolling hatch. But these problems appear simpler than those involved in the other techniques.

This configuration is also amenable to some alternate uses that would enhance the utilization of the range. By allowing the front of the building to be opened and lining the interior with RF absorbent material as shown in Figure 8.

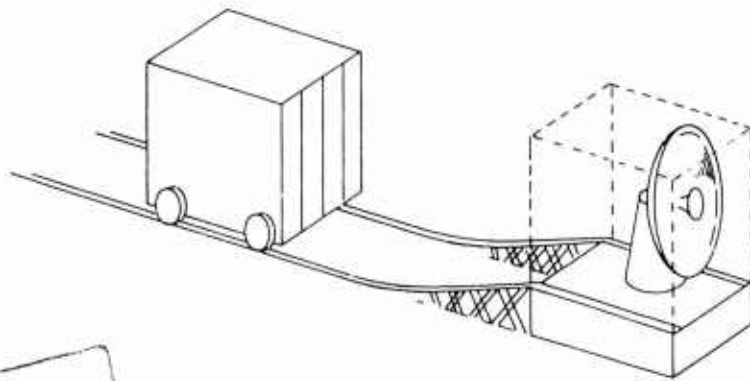

CONSTRUCTION: The building would consist of a large structure. To clear the antenna for position against the side, the roof would collapse downward around the antenna.

ADVANTAGES: One of the simplest in design. The structure completely encloses the antenna.

DISADVANTAGES: Large size and weight. The structure is a two-story structure. The antenna is exposed to reflections.

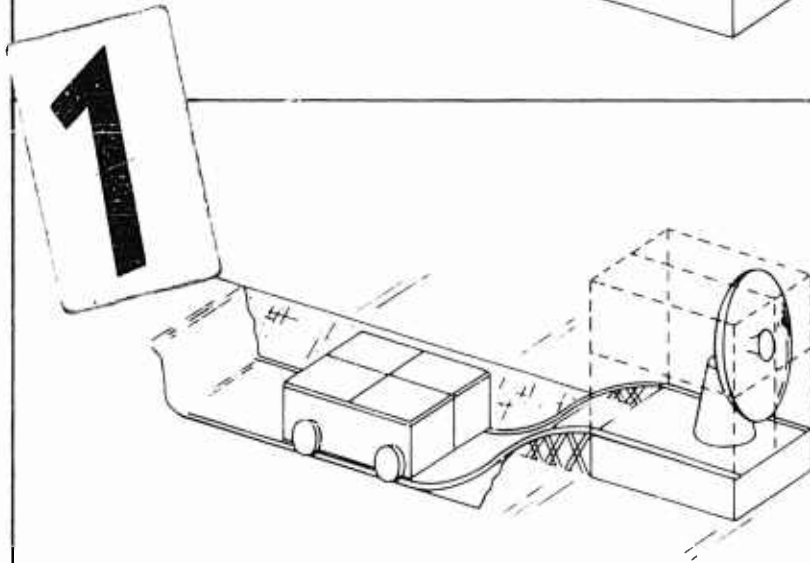

CONSTRUCTION: The building would consist of a large structure which would collapse upward. To clear the antenna for position against the side, the roof would collapse downward around the antenna.

ADVANTAGES: Gets the second story clear of the antenna.

DISADVANTAGES: A large number of difficult joints. A short ramp would create a large structure.

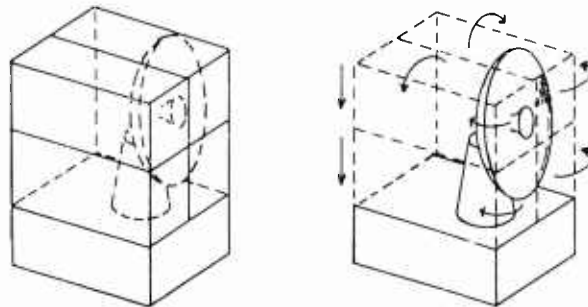

CONSTRUCTION: The building would consist of a large structure. To clear the antenna for position against the side, the roof would collapse downward around the antenna.

ADVANTAGES: This method would completely enclose the antenna.

DISADVANTAGES: A large number of difficult joints. A folding roof.

Fig. 6 - Antenna Enclosures



CONSTRUCTION: The building would consist of a stationary first story and a movable second story. To clear the antenna for testing, the second story would be rolled down a large ramp to the rear of the building (1), and then rolled far enough to the rear (2) so as not to interfere with the antenna pattern testing.

ADVANTAGES: One of the simplest methods of clearing the antenna, and it gets the second story structure completely out of the way during tests if moved a large distance.

DISADVANTAGES: Large size and weight creates a great mechanical problem in moving the second story structure. The building would have to be moved a large distance because of reflections.



CONSTRUCTION: The building would consist of a stationary first story and a movable second story which would collapse upon itself to reduce this height to approximately 35 feet. To clear the antenna for testing, the second story would be rolled down a ramp in the rear into a large pit (1) and be collapsed upon itself, to keep the roof near ground level.

ADVANTAGES: Gets the second story completely clear of the antenna during testing periods.

DISADVANTAGES: A large number of difficult mechanical problems are involved. A reasonably short ramp would create large stresses.



CONSTRUCTION: The building would consist of a stationary first story and a collapsible second story. To clear the antenna for testing, the roof would be folded upward and outward to a position against the side walls (1). Then the two halves of the second story would be collapsed downward around the outside of the first story.

ADVANTAGES: This method would completely clear the antenna for testing.

DISADVANTAGES: A large number of difficult mechanical problems are involved particularly with the folding roof.

Fig. 6 - Antenna Enclosures

2

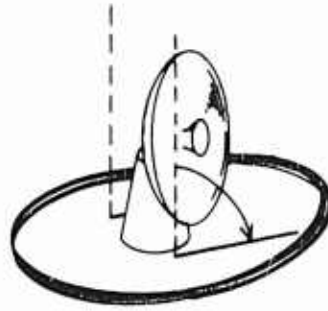
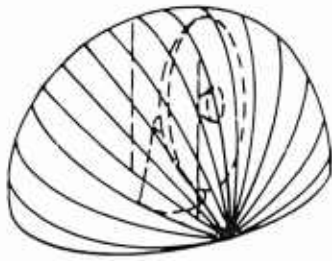

CONSTRUCTION: This structure is built on a flat surface to provide a wide base. The structure is wide, requiring a wide base. The antenna is mounted into pits.

ADVANTAGES: Complete protection.

DISADVANTAGES: A complex structure. Not weather resistant.

**1**

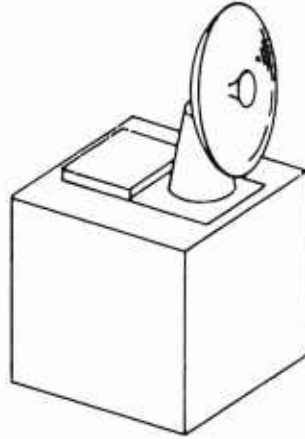
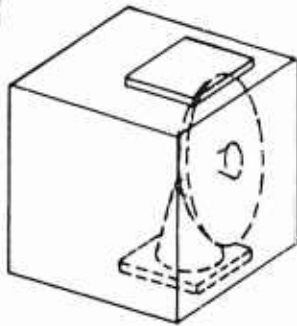

CONSTRUCTION: The building is a cube. The antenna is sliding to the top of the cube. The antenna is trapped in the top of the cube. The antenna is raised up.

ADVANTAGES: This is the simplest structure to yield the best mechanical protection.

DISADVANTAGES: The antenna is not tested, guides for the antenna are placed on the top of the cube.

Fig. 6 - Antenna Enclosures (Cont'd)



CONSTRUCTION: This structure would resemble two baby carriage hoods placed face to face, with large gin poles to erect and retract the structure. The structure must clear a vertical height of 65 ft., requiring that the ellipse of the hoods be approximately 120 feet wide. To clear the antenna for tests, the hoods would be lowered into pits (1), then the gin poles lowered into pits (2).

ADVANTAGES: Completely clears the antenna for testing.

DISADVANTAGES: A complex mechanical problem, highly subject to wear and weather damage.



CONSTRUCTION: The building would consist of a solid structure with a large sliding trapdoor in the roof and a large elevator on which the antenna is assembled. When the antenna is ready for testing, the trapdoor is rolled to the rear (1), and the large elevator raised until its floor is flush with the roof (2).

ADVANTAGES: This is the simplest approach to the problem that will also yield the desired results. Requires the least complex mechanical arrangements.

DISADVANTAGES: The antenna will be unnecessarily high for higher frequency testing, and this method may require long RF cables on waveguides from the antenna to the receiver, unless receiver is placed on the antenna platform.

Fig. 6 - Antenna Enclosures (Cont'd)

2

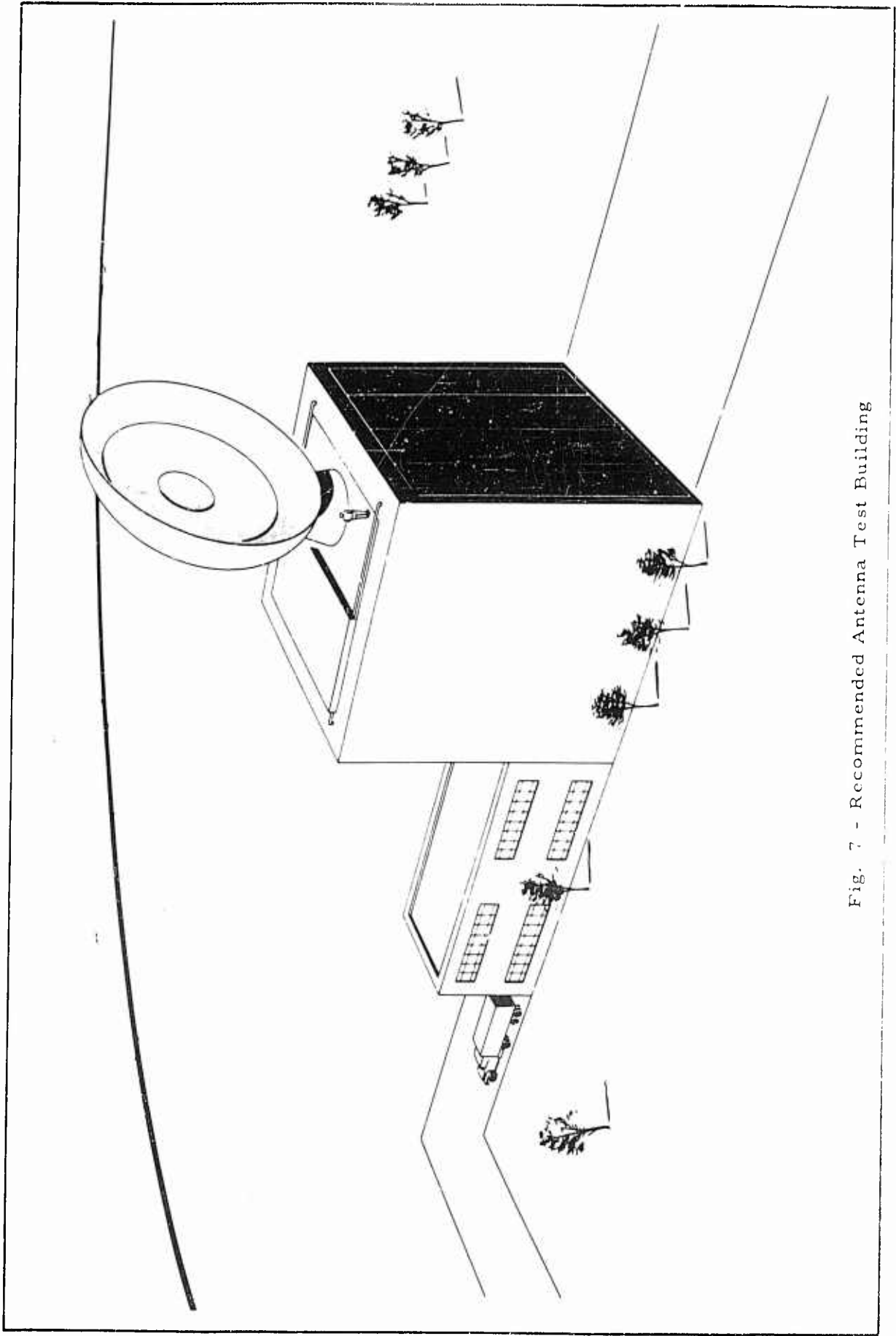

Fig. 7 - Recommended Antenna Test Building

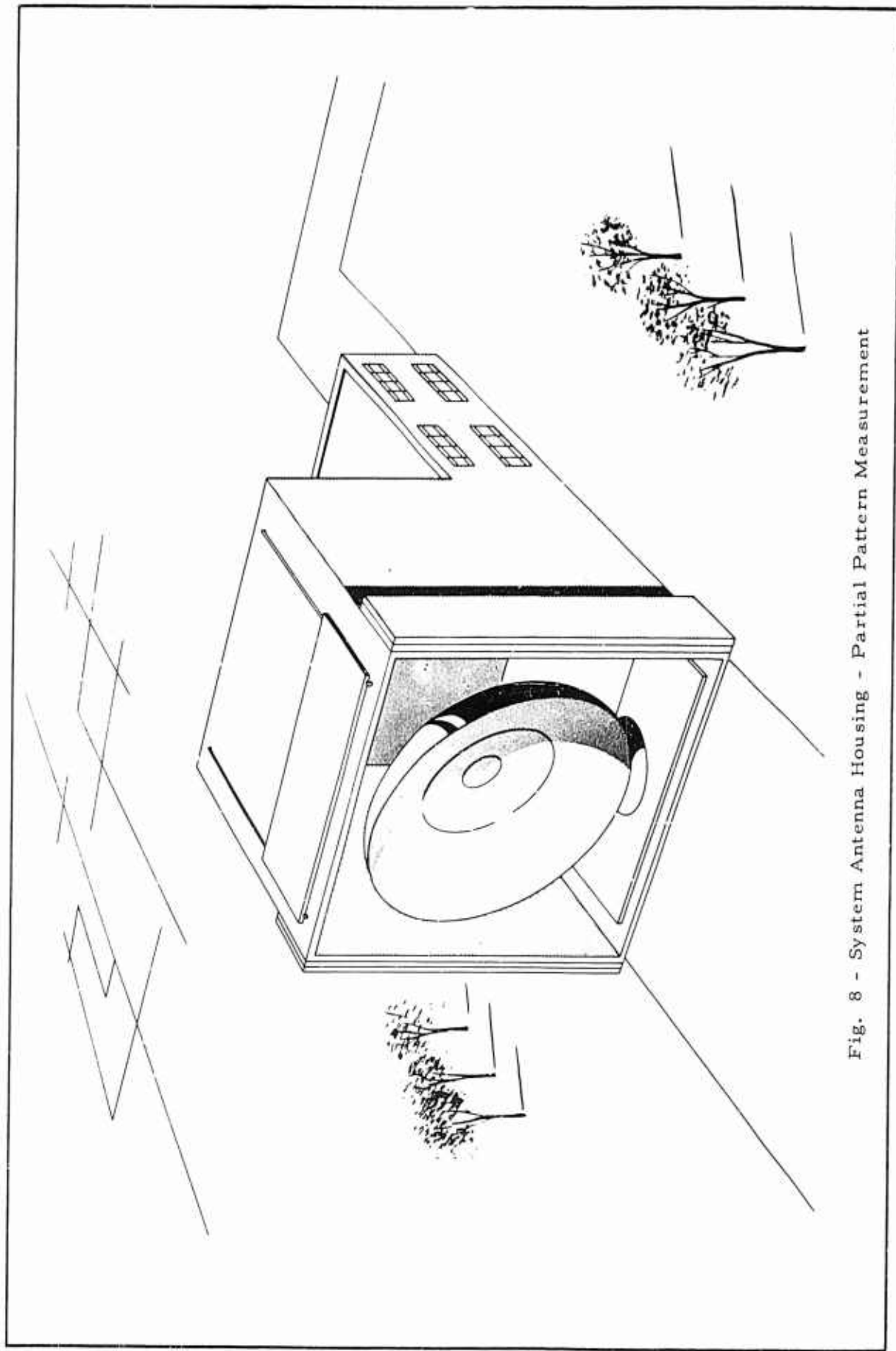

Fig. 8 - System Antenna Housing - Partial Pattern Measurement

tests may be conducted on the main beam and first side lobes without raising the antenna. This would be particularly useful in setting up an antenna or making quick checks of a modification. Also portable antennas could be assembled outside the building and then rolled onto the elevator for testing. By providing enough depth to the building and suitable handling equipment it would be possible to work on more than one antenna at a time

### 3. The Ramped Range

The reflection range suffers the disadvantage that as the frequency of operation increases it becomes increasingly difficult to maintain the ground surface as smooth as required for specular reflection from a single point, or more properly from a single area (because the transmitter has a finite size). Practical methods of grading a large area with the passage of time will produce dips and rises which will create additional points of reflection, some of which will direct energy towards the receiving aperture

If the major axis of the range is raised so that a sloping ramp is created on either side as shown in Figure 9, this problem does not become critical so quickly. On a ray theory basis alone, any energy striking the ramp would be reflected at an angle that would carry it away from the receiver. Over most of the range length on a long range even a very shallow ramp angle would cause most of the reflected rays to miss the receiver by a wide margin. From this verbal description it becomes apparent that local variations in the ramp will have to be much greater than in a flat plane to cause undesired reflection into the receiver. The grading tolerance problem is reduced to maintaining a sharp, straight apex if a ramp is used

Considering the problem more properly requires that the wavelength of the energy illuminating the ramp be considered. At low frequencies where the wavelength is large, the ramp does not exist for all practical purposes. At the high end of the frequency range, 40 Gc, the ramp is many wavelengths high and very many wide, and so its effects would be very noticeable if it were sufficiently smooth. (In practice its surface texture--most likely grass--will cause it to act as a diffuse scatterer.) Thus it can be seen that there will be some frequency region at which it will attenuate the reflected ray sufficiently that the range no longer need be operated in the reflection mode. This is desirable because when the grading tolerances become too severe, the range will not

operate in the reflection mode anyway. The presence of the ramp also eases the grading tolerances for the reflection mode of operation, and only at the expense of reducing the effective amplitude of the image source. This is of little consequence for this only means that the amplitude variation across the aperture decreases to the same extent that the phase variation increases. The two effects compensate for each other.

The degree of reflection attenuation theoretically achievable is not too promising. Typical figures at full range length are 3 db at 1 Gc and 19 db at 40 Gc. The primary advantage of the ramp is that it reduces the surface grading tolerance problem by providing attenuation at the shortest wavelength where grading tolerances are most severe. It appears that the ridge of the ramp must be set in place with the strictest of tolerances, namely, 0.75 inch through the main reflection zones.

#### 4. Use of Ray Blocking Fences

A fence may be placed on the range perpendicular to its axis and near the point of specular reflection to block the energy traveling toward the ground. Its effect is to screen the receiver from the image of the transmitter. However, when the physical wavelength is taken into consideration it becomes apparent that energy can reach the receiver by diffraction over the edge. There are several paths by which this may occur as indicated in Figure 10. An analysis of these effects shows that, for a representative example, at 7 Gc the diffracted energy reaching the receiver is 15 db or greater below the direct path energy. This implies a nonuniformity of illumination of  $\pm 1.5$  db as well as a correspondingly small error in the pattern measurement. If a fence is used for tests from 7 to 40 Gc the range no longer need be operated in the reflection mode and surface tolerances need not be considered above this frequency.

In the design to be recommended the antenna height required at 7 Gc is 1.8 ft. operating in the reflection mode. Using a fence for operation above this frequency, a fence 10 ft. high located 1000 ft. away may be used if the antenna is raised to 20 ft. More analytical and experimental work is needed on this problem to determine optimum configurations.

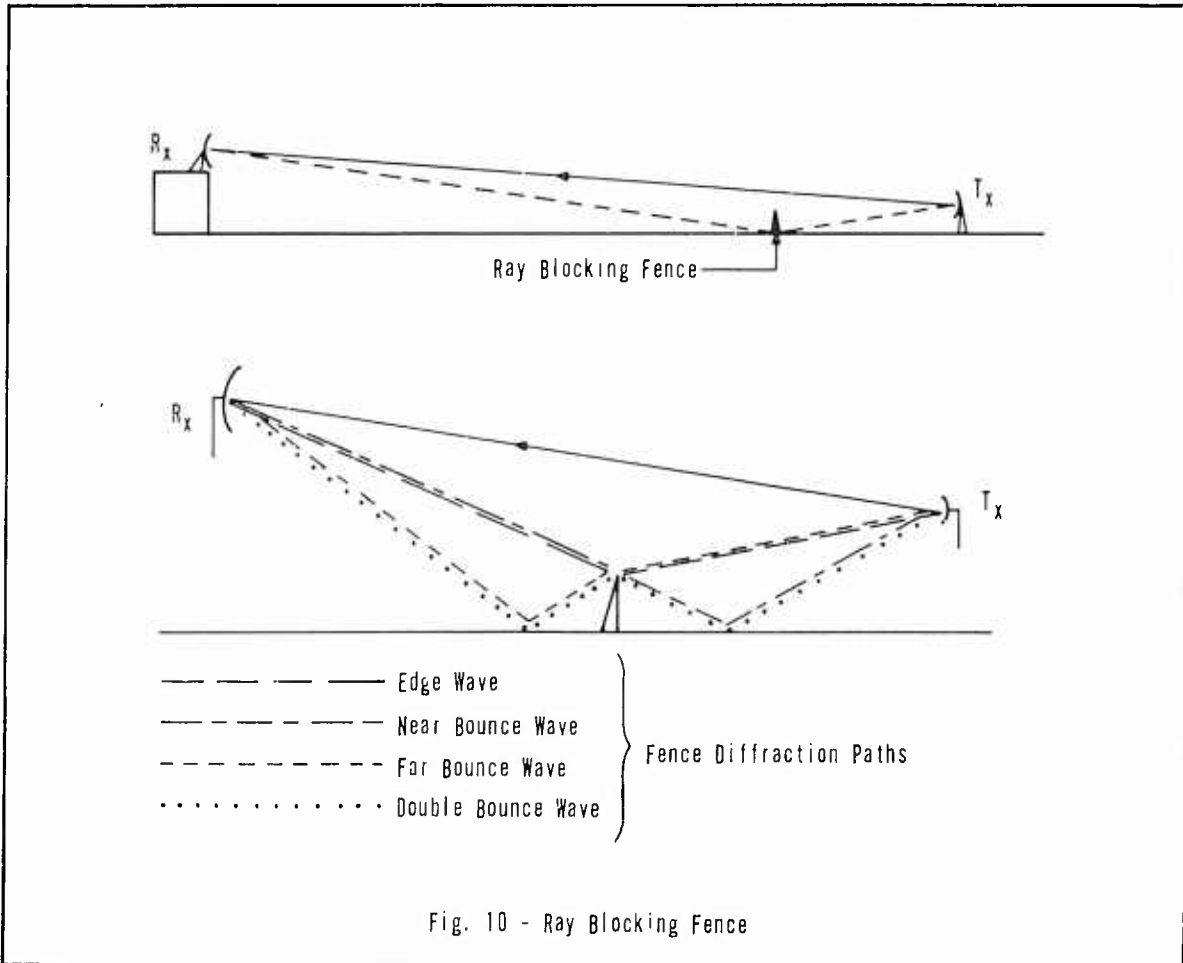
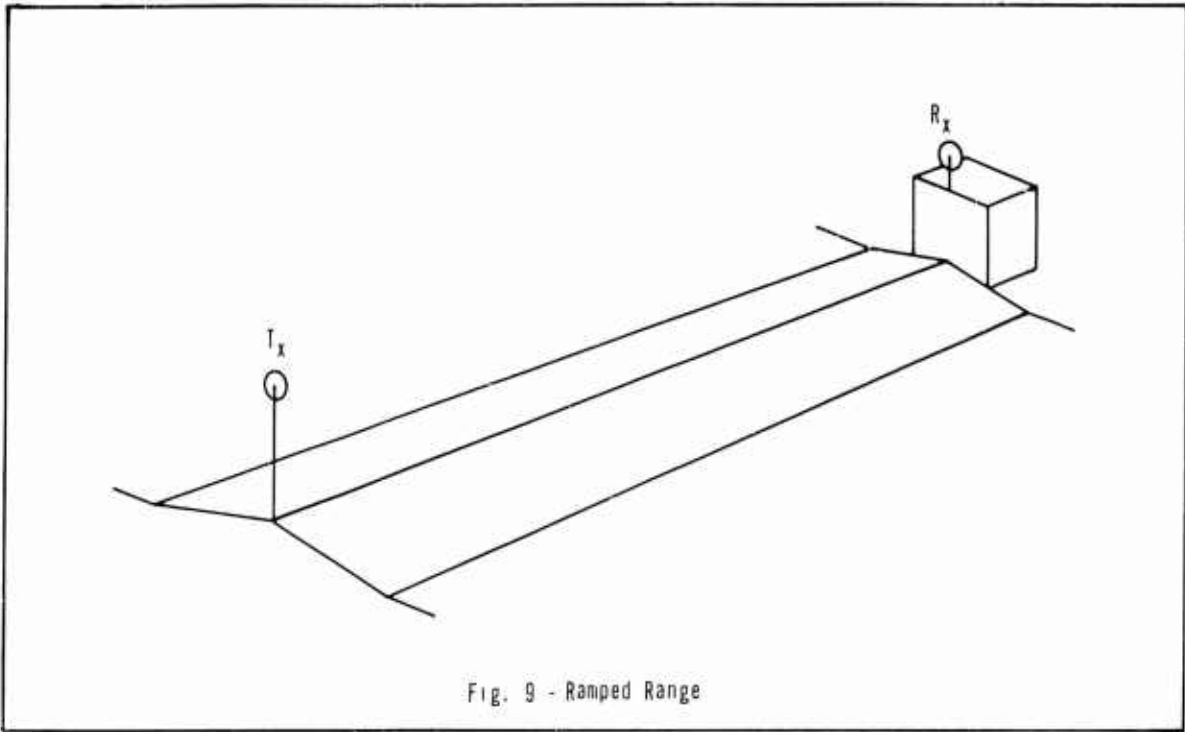

## 5. Range Surface

At grazing angles of incidence,  $1/2^\circ$  and smaller, the surface material is of little consequence as long as it is a dielectric and it is flat. However, when the range is "tuned" to a particular frequency by changing antenna height or antenna separation, the angle does not necessarily stay so small, nor will a practical material remain flat. The use of ramps and fences will ease the grading tolerances, but the range covering still must be considered.

Ideally it would be a material such that the reflection coefficient for both horizontal and vertical polarization is relatively constant and is close to  $-1.0$  for grazing angles up to  $10^\circ$ . Most materials have the property that the reflection coefficient for vertical polarization decreases much more rapidly than for horizontal polarization. At the so-called "Brewster angle" where its magnitude is zero, it changes sign. The Brewster angle is roughly  $30^\circ$  for water. Unfortunately no practical material exists with such ideal properties. The limited information in the frequency range of interest and for forward scatter at small angles for concrete, grass, and macadam allows one to guess that they all have about the same merit. More experimental data is required for detailed analysis.

For a very large range such as that being considered here, the economic factor becomes important. At the Verona site the choice will probably be grass or macadam. Grass will require more annual expenditures than macadam because of mowing, but a relatively narrow hard top strip will still require mowing beyond its edges and the edges themselves could constitute a scattering source that would affect the measurement of very high angular resolution antennas. The choice of material does not affect the over-all feasibility of the range.

## 6. Range Placement and Length

To this point the discussion has been concerned with Zones I and II, the antenna test range itself. The choice of range length and placement involves the Fraunhofer criterion and Zone III, the existing site locale.

The maximum diagonal available within the confines of the existing Verona test site is 8200 feet. If a range were constructed of this length, 60-ft. apertures could be tested to 1120 Mc. However, the alignment of this axis is such that a number of problems are created because of already existing structures and the terrain. Preparation of the range would be very expensive and even then

not all difficulties would be eliminated. Neither the antenna test range nor some of the other operations at the Verona site would be completely satisfactory. Figure 11 shows a practical alignment for a 6000-ft. range, which will allow 60-ft. apertures to be tested at the Fraunhofer spacing to 820 Mc, and which will allow the present functions of the site to continue with the least interruption.

This alignment permits satisfactory access and enough separation for practical signal processing to eliminate the Zone III scattering and reflection. Unfortunately, the presence of antennas on the border of the zone may create very strong reflections at certain frequencies. However, these can probably be minimized by finding an optimum "storage" position for them when they are not in use. The ellipse also indicates that control should be obtained over some additional property. Possibly some kind of agreement would allow the replacement of fence rows with short wood posts, (since fences may constitute strong reflection sources), but permit the continued agricultural use of the land for crops of limited height.

#### 7. Variable Range Length

The reflection range equation,  $4 H_R H_T = \lambda R$ , shows that transmitter height and range length may be varied together. This suggests that the transmitter unit should be allowed to take on more than one position. If a continuously variable range length is considered there immediately arises the problem of providing suitable connections between the receiver building and the transmitter unit. This problem can be taken care of by providing a number of fixed locations for the transmitter along the range. Since the transmitter antenna height can be varied to compensate for range length, fixed stations are feasible. By making a suitable choice of range lengths, it is possible to meet all desired characteristics with four fixed stations along the range.

Figure 12 shows the transmitter height as a function of frequency for four range stations located at 650, 1400, 2800 and 6000 feet. A maximum transmitter antenna height of 40 feet was used in determining these values such that the Fraunhofer criterion would be satisfied for 60-ft. apertures over the entire frequency range up to the limit imposed by the length of the range axis. This limit occurs at 820 Mc and for higher frequencies the maximum aperture for Fraunhofer testing decreases as shown in Figure 13.

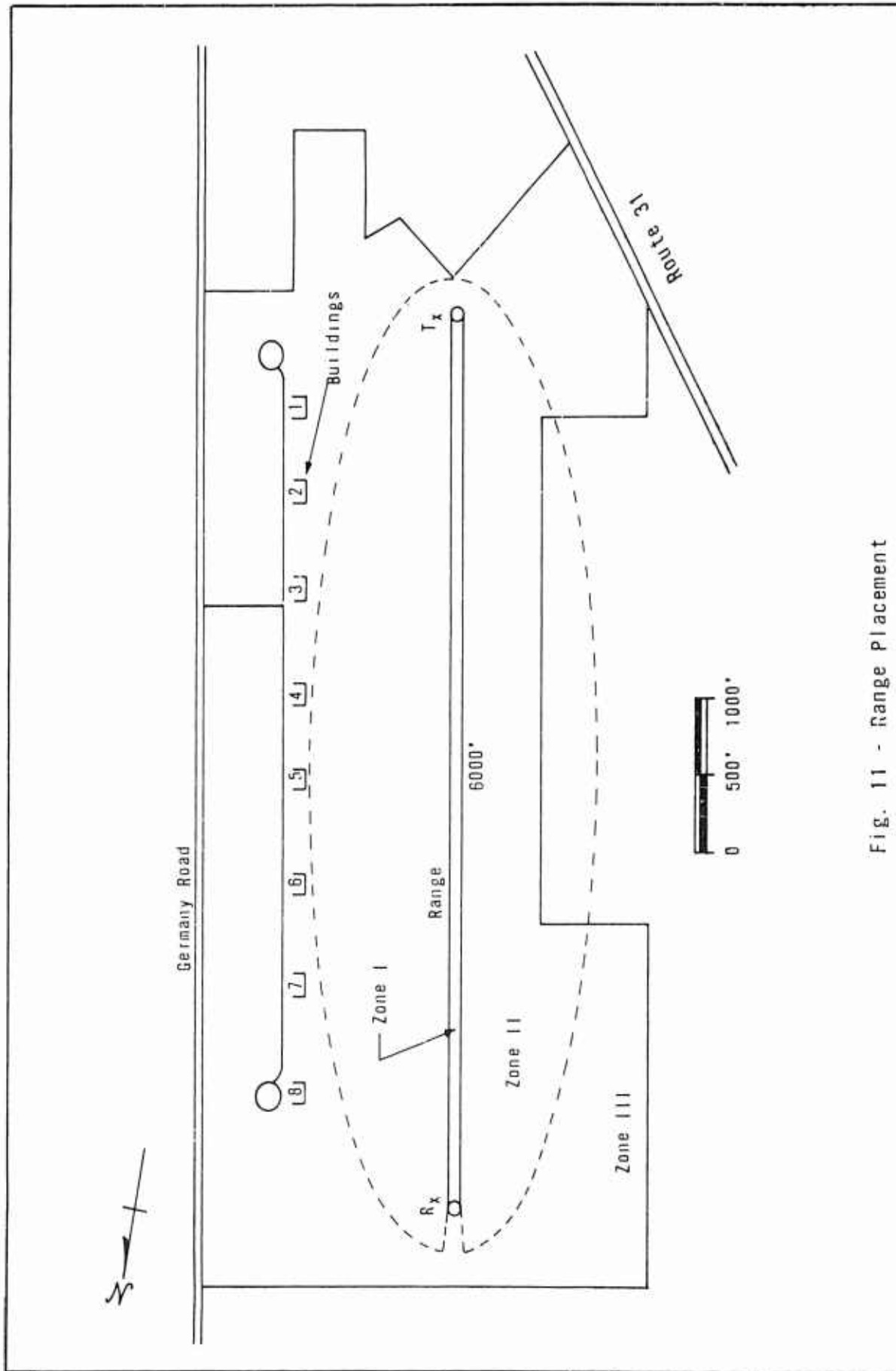
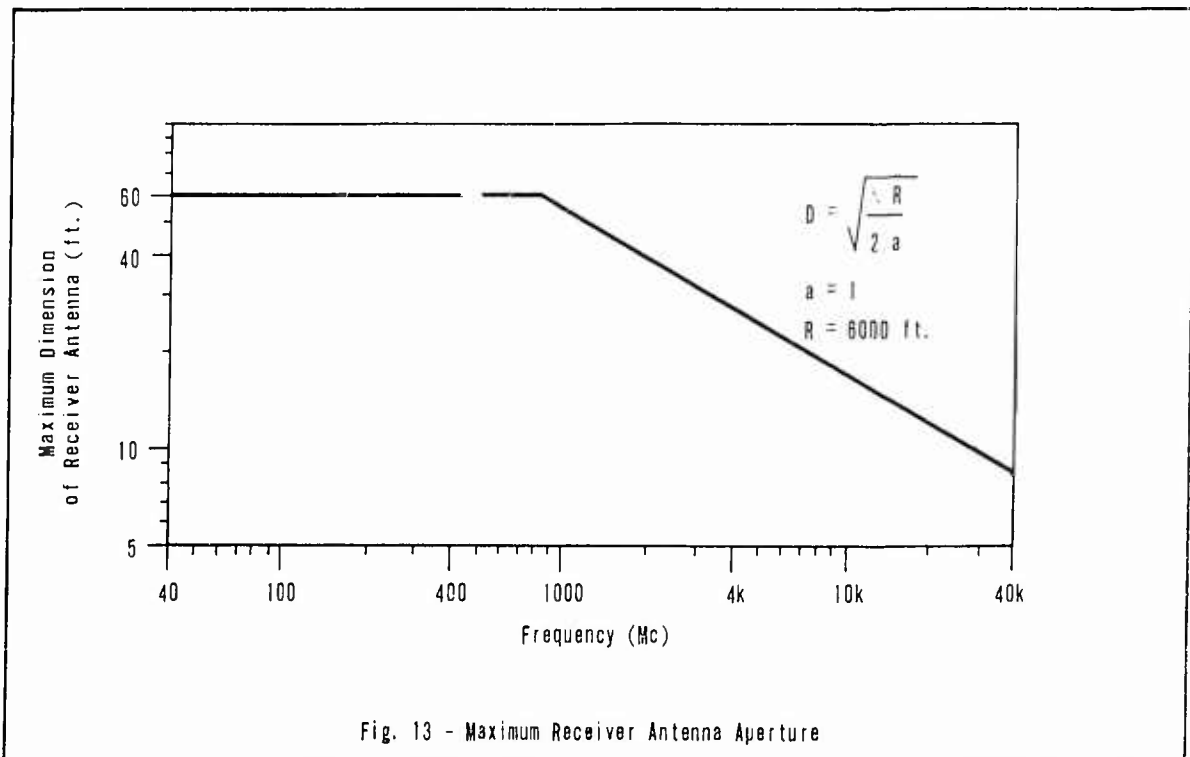
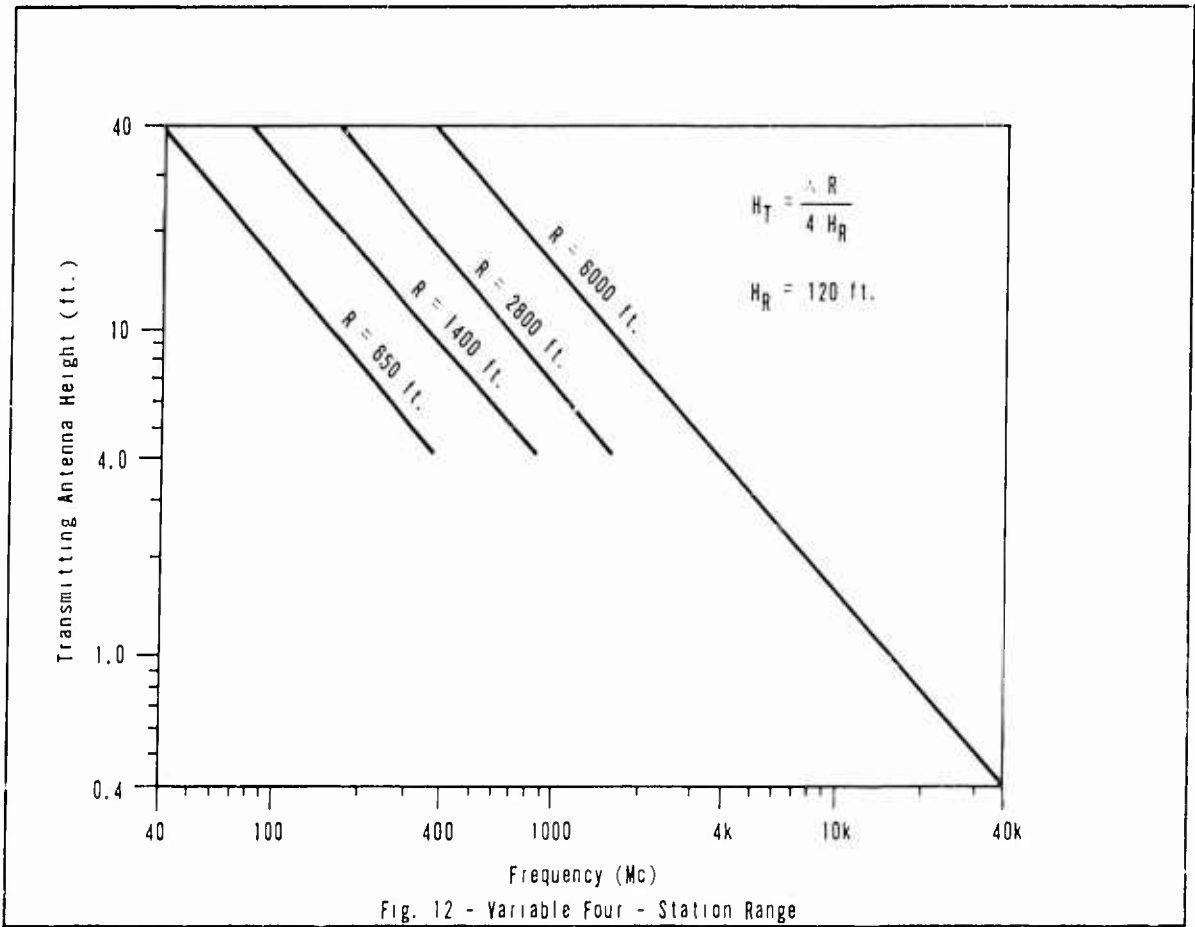

Fig. 11 - Range Placement



The maximum transmitter height may be reduced by providing more range stations.

#### 8. Signal Processing

Signal processing is the key to the feasibility of a successful antenna test range on the Verona site. Its function is to remove undesired returns that will arise by reflection and scattering from objects off the controlled range. The Verona site has a number of flat-sided buildings and antennas that could cause a great deal of trouble in testing high gain antennas. Their effects can be removed by a properly designed system.

Any energy traveling to the receiver by way of another object must travel a longer distance than the direct ray, and so take a longer time. The optimum layout for Verona gives a minimum time delay of 0.4  $\mu$ sec. If a pulsed system is considered the receiver must be gated off within this time after the RF pulse is radiated. The transmitted pulse width is unimportant, but its rise time must be fast enough to allow a peak value to be measured and then the receiver gated off to a level of 60 db below the "on" state within the 0.4  $\mu$ sec. By keeping the receiver turned off until the pulse is radiated noise effects and interference from other site radiators can be minimized.

An FM system may also be considered where the transmitter is swept across a given frequency range and a comparison signal is provided via another path. The desired signal will generate a characteristic audio beat frequency while reflected and scattered returns will produce beats at other frequencies which may be removed by filtering. For the path lengths involved at Verona, a 2 Mc frequency sweep is required.

The receiver bandwidth requirements for the pulse and FM systems are essentially the same. Theoretically either system may be used over the entire frequency range, however, practical considerations indicate that the pulse system not be used at the lower frequencies, and that the required linearity of frequency sweep will be very difficult to attain at the higher frequencies. Use of the FM system up to approximately 1000 Mc and the pulse system down to approximately 500 Mc is suggested.

Signal processing is not without its difficulties. The bandwidth requirement for either system, 2 Mc, may cause some inaccuracy in measuring deep nulls and will cause inaccuracy in measuring frequency sensitive antennas. In the latter case CW testing may be used, but the patterns obtained will then be subject to inaccuracies caused by Zone III reflections. Also the gating process in the receiver or the frequency "flyback" step in the FM system will create noise of their own. This noise can be held to a tolerable minimum by careful engineering and maintenance of the transmitting-receiving systems.

#### 9. RF Power Requirement

The power required from the transmitter will depend upon the sensitivity of the receiving system, the signal-to-noise ratio required to hold the measurement error to the desired level, the dynamic range to be obtained in the antenna pattern, the maximum gain of the antenna under test, the path attenuation, the transmitter antenna gain, and fixed system losses--primarily due to cabling from RF heads to antenna terminals.

in a system where all parameters are well-controlled, such as this, it should be possible to attain a sensitivity of -100 dbm across the entire frequency range. Since the various measurement errors will accumulate, the error contributed by the signal-to-noise ratio must be held to a reasonable value, say 1/2 db. This requires a signal-to-noise ratio of 25 db.

The pattern dynamic range of 60 db is one of the major factors in setting the power requirement. An analysis of the power requirements shows that when operating at range lengths required by the Fraunhofer equation an essentially constant factor of 15 db may be introduced to which the difference in antenna gains must be added. If four fixed stations are used an additional 7 db must be included to properly account for the path losses. In order to satisfy the Fraunhofer illumination requirements the gain of the transmitting antenna will always be at least 15 db less than the antenna under test. If antennas are available such that the gain difference does not exceed 25 db, and 8 db is allowed for fixed system losses, then the total power requirement does not exceed 10 watts across the frequency range.

## 10. Transmitter Unit

The transmitter unit is to be movable between four or more range stations from 650 ft. to 6000 ft. and is to provide heights adjustable from 40 ft. down to 4 inches. The maximum height can be reduced if more stations are provided. The unit will carry RF heads and antennas for the 40 Mc to 40 Gc frequency range. The antenna mount must rotate so that both horizontal and vertical polarization can be provided. To reduce feed line losses the RF heads in the microwave region may be mounted at the antenna.

In order to avoid creating a line source of scattering a wheeled vehicle having enough tire area to provide low surface contact pressure is required. It should be noted, though, that this line source, which might be either rails or ruts, would be very close to the range axis and would only affect measurement of very high angular resolution antennas.

The unit should have jacks built in to stabilize the platform and tower. Each range station should have concrete jack pads flush with the surface. Electrical power and control connections would be made at each range station through a plug box mounted below the range surface.

Trigger signals for the pulse system and an pilot signal for the RF system would be generated at the receiver building and transmitted to the RF heads. Remote control of antenna height, polarization, and RF tuning must be provided for efficient operation of the range. The extent to which band switching and antenna selection are remotely controlled will depend upon economic factors. Monitoring circuits for critical transmitter parameters must also be provided. Remote control of the distance to the transmitter unit is probably unnecessary until the range utilization becomes very high.

## F. RECOMMENDATIONS FOR AN ANTENNA TEST RANGE ON THE VERONA TEST SITE

1. Range length approximately 6000 ft. oriented as indicated in Figure 11.
2. Range to be operated primarily in the reflection mode.
3. An enclosed antenna erection and receiving system building with an elevator and pedestal to raise 60 ft. diameter antennas through the roof.

4. The maximum antenna center height satisfy the equation  $H_R = 2.4 D$  (maximum vertical dimension of antenna) up to a height of 120 ft.
5. A wheeled mobile transmitter unit be provided for operation at four or more fixed stations down the range.
6. Transmitter antenna height be continuously variable from 4 inches to 40 feet. The maximum elevation may be reduced by providing more range stations. The normal minimum height will be 1.8 ft
7. Approximately 10 watts of RF power be available from 40 Mc to 40 Gc.
8. An FM transmitting and receiving system with a 2 Mc bandwidth be used from 40 Mc to approximately 1000 Mc.
9. A pulsed transmitter and gated receiver be used from approximately 500 Mc to 40 Gc
10. That the source antennas have 15 to 25 db less gain than the antennas under test, but in no case to have maximum horizontal or vertical dimension exceeding 0.414 times the same dimension of the antenna under test.
11. A range surface 6000 feet long by at least 100 feet wide be prepared such that its final shape will remain stable throughout the seasons.
12. The lateral cross section of the range shall be a ramp of  $10^\circ$  slope, (sloping down from either side of the central axis of the range), each side 50 to 100 ft. wide.
13. The prepared range surface ridge shall have no rises or depressions greater than 0.75 inches.
14. A fence be provided to block ground rays above 7 Gc.
15. The area included in an ellipse of major axis 6400 feet and minor axis 2230 feet with foci at the receiver building and 6000-foot range station be clear of all buildings, trees, towers, fence posts, shrubs, large rocks, ditches, and other sources of scattering. The area immediately to the rear of the antenna building is excluded.

## G. ANTICIPATED PERFORMANCE CAPABILITIES

1. In the frequency range 40 to 820 Mc apertures up to 60 ft. diameter can be tested at  $2a D^2 / \lambda$  with  $a = 1$ . The far field pattern will be obtained in the first null down to a level of 23 db below the peak of the main beam. Further mathematical and experimental analysis is required to determine the far field null depth measurement accuracy at points away from the main beam.

2. The maximum aperture that can be tested at  $a = 1$  from 820 Mc to 40 Gc varies from 60 feet to 1.5 feet following the rule:

$$D_{\max} = 55\sqrt{\lambda} \text{ (ft)}$$

3. Pattern ranges of 60 db can be recorded from 40 Mc to 40 Gc.

4. Accuracy of recorded pattern values will be a function of the frequency range and the recorded amplitude level. The accuracy will be greater for long wavelengths and high levels. The primary factor affecting accuracy at moderate and low levels will be the directivity of the main beam of the antenna under test and its orientation in relation to the scattering field of the site. Atmospheric stability will affect accuracy with increasing significance as frequency increases. Accuracy will also be affected by the design and maintenance of the receiving/recording system. It should be possible to maintain  $\pm 1$  db pattern accuracy over a dynamic range of at least 30 db except in the frequency range 7 to 15 Gc where the accuracy will be approximately  $\pm 1.5$  db. Accuracy predictions to 60 db dynamic range require further experimental and analytical studies.

5. Horizontal polarization measurements can be made at almost any time. Vertical polarization measurements at the closer range stations may be less accurate when the range surface is wet.

6. Measurements of antennas at nondesign frequencies are subject to all the above conditions. However, the maximum aperture limitation may be readily exceeded when measuring harmonics. This will mean that measurements are being made at fractional values of  $a$ , and so although the full dynamic range of the pattern may be observed, the free field pattern dynamic range will be reduced.

## H RECOMMENDATIONS FOR FURTHER DEVELOPMENT

1. That the reflection range parameters be studied experimentally in detail to develop criteria that will allow the minimum receiver height to be reduced
2. That the range surface shape factors be studied experimentally to better predict the level of scattered energy present at the aperture of the antenna under test and to refine methods for reducing the scattered level. Ramp effectiveness and slope tolerances must be verified.
3. That the techniques for operating the range at frequencies above approximately 5 Gc be further developed including consideration of techniques for easing the range grading requirements. The theory set forth in this report must be tested experimentally
4. That range surface materials be experimentally investigated and economic factors studied to determine the optimum material for a practical range.
5. That the implementation of special techniques for generating and processing the transmitted and received signal be developed for use in a range.
6. That economic trade-offs against range performance be investigated for the receiver building, range surface, transmitter unit and remote control functions
7. That the effect of antenna support structures on illumination field uniformity be studied experimentally and theoretically
8. That techniques for measuring and monitoring range performance be developed.

CHAPTER II  
NULL DEPTH MEASUREMENT LIMITATIONS

A. PATTERN MEASUREMENTS

The accepted measurement procedure for obtaining an antenna pattern involves plotting relative power level while rotating the antenna under test. A power reference level is established on this plot for conversion to an absolute power pattern at selected values of frequency and of the radiation field. The method requires the use of two antennas, one radiating at a constant power level at a given frequency and polarization while the power level received by the second antenna is recorded as a function of the angle of rotation when the antenna whose pattern is being measured rotates with respect to the other and in a particular plane. Which antenna radiates is not important, since the direction of power flow is not related to the field pattern.

For the sake of clarity in this discussion we will define the antenna whose pattern is to be measured as the system antenna and the other antenna as the test antenna. The test antenna will be considered as the antenna which is used as the radiation source for reasons which will become apparent in the following sections.

The complete knowledge of an antenna's field structure is very difficult to measure since, as in many other measurement problems, the presence of the measuring system itself serves to change the true value of the quantity to be measured. It is therefore very important to be able to specify the nature and order of magnitude of this change in order to actually interpret the measured data. A theoretical analysis may be presented to define the nature and relative magnitudes of the site effects of the measurement system, which includes the site itself, upon the normalized antenna parameters. The remainder of this report is concerned with a number of such analyses and with considerations of various techniques for overcoming the implied limitations.

Even in free space it would be difficult to accurately obtain the far field pattern of an antenna. Measurements made at a finite spacing between the source and the receiver will modify the theoretical far field pattern. This chapter is devoted to an analysis of the effects of this situation upon the pattern. It has been customary to consider that the far field pattern is obtained when the minimum spacing,  $R_{\min}$ , between the antennas satisfies the Fraunhofer equation:

$$R_{\min} = \frac{2D^2}{\lambda}$$

where  $D$  = maximum aperture dimension of the antenna under test

$\lambda$  = wavelength

It will be shown that this criterion is satisfactory for obtaining the peaks of the pattern, but because it implies an allowable phase variation across the aperture under test of  $\lambda/16$ , the recorded pattern nulls will deviate from the theoretical below a certain level. The level at which this occurs can be controlled by modifying the Fraunhofer equation to read:

$$R_{\min} = \frac{2 a D^2}{\lambda}$$

The required value of the parameter  $a$  for a far field pattern accurate to a certain level can be determined by graphical means.

#### B. ANALYSIS OF NULL DEPTH MEASUREMENT

The analysis may be started by examining the classical case of a point source illuminating a plane at a finite distance  $R$ . From Figure 14 it may be seen that the phase variation across the plane with respect to the center will consist of a series of rings about the axis between the plane and the point source. Therefore for a given value of separation,  $R$ , the phase variation, across the plane in the  $Z$  or  $Y$  direction would vary as a function of  $R + N \lambda/2$  where  $\lambda$  would equal the wavelength and  $N$  would be an integer. The converse would also be true of course, that is, for a given uniform plane illumination a point moving along the  $X$  axis would pass through similar minima and maxima as the distance to the point from each ring would change from even to odd integers (phase cancellation and phase interference). In any case these symmetrical areas (known as Fresnel zones) would cause any amplitude measurement to be a function of distance ( $R$ ) with the variation with increasing distance becoming smaller and smaller until  $R$  would be infinite. The value of  $R$  for which this phase variation becomes negligible would indicate the boundary of the true far field measurement (Fraunhofer Region).

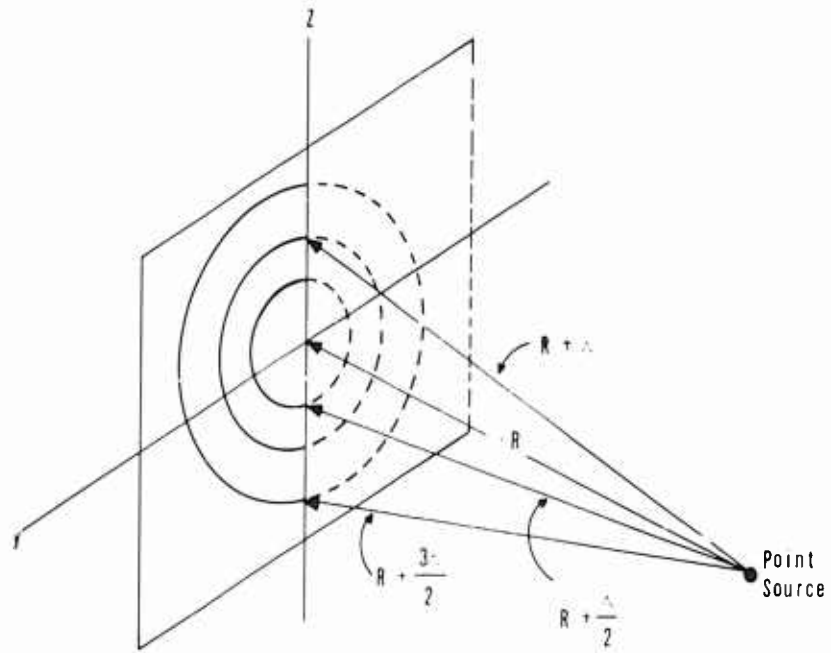

Fig. 14 - Phase Variation Across Plane

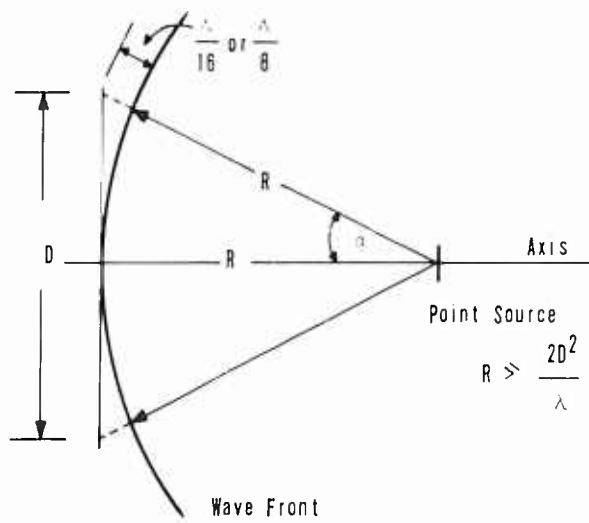

Fig. 15 - Maximum Phase Variation (Point Source)

The criterion established in previous literature<sup>1</sup> allows a maximum phase variation of  $\lambda/16$  across the area occupied by the antenna under test. This is only a portion of one Fresnel zone. This criterion is certainly justifiable as will be seen. However, the criterion must be carefully examined with respect to the dynamic range of the measurements to be made. For example, the value of this phase variation would be a function of the antenna aperture and could be plotted with respect to the value of R in wavelengths as shown in Figure 16. In this figure it may be seen that the phase variation increases exponentially as the range is decreased. The phase variation is greater for increasing points on the plane for any given value of R.

By specifying the maximum phase variation then the relationship between D and R may be derived from the same geometry. For the criterion of a maximum phase variation of  $\lambda/16$  the relation is : (Figure 15)

$$\frac{D}{2} = \sqrt{2R \left( \frac{\lambda}{16} \right) + \left( \frac{\lambda}{16} \right)^2} \quad (1)$$

then

$$\frac{D}{2} = \frac{1}{4} \sqrt{\lambda 2R} \quad , \quad \left( \frac{\lambda}{16} \right) \ll \frac{\lambda}{16}$$

Hence

$$D^2 = \frac{R\lambda}{2} \quad \text{or} \quad R > \frac{2D^2}{\lambda} \quad (2)$$

If the maximum phase error is permitted to be  $\lambda/8$  then the resulting separation distance will be one-half that determined by a maximum phase error of  $\lambda/16$ . This also corresponds to a power error of .25 db for a circular aperture of diameter D. Figure 16 is normalized plot of this relationship. Considering a finite plane of dimension D as the aperture of the test antenna, the error from a true plane wave illumination would then be related similarly to the antenna's separation. Previous work has shown that the relationship between antenna gain and the aperture size (area) for a plane wave illuminated aperture is:<sup>2</sup>

$$G = \frac{4\pi A}{\lambda^2} \quad (3)$$

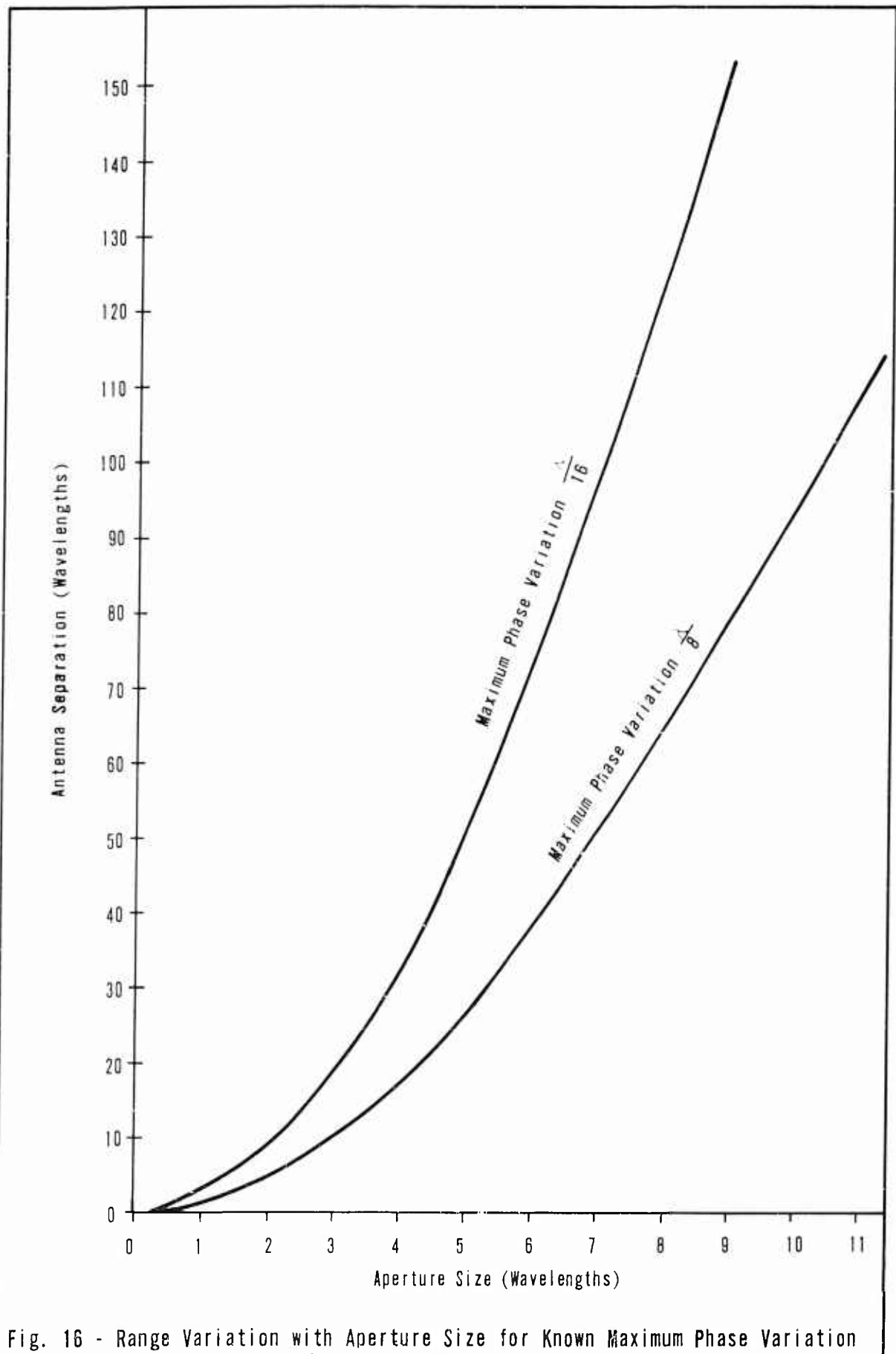

Fig. 16 - Range Variation with Aperture Size for Known Maximum Phase Variation

where  $A$  is equal to the aperture area and therefore is proportional to  $D^2$ . To maintain a particular maximum phase deviation over the aperture then would indicate that the gain for that aperture would be a function of  $R$ .

For a given antenna the difference between the maximum theoretical gain and the gain measured at a finite distance  $R$  is a function of  $R$ . The relationship of this gain variation as a function of range has been derived for simple electromagnetic horns.<sup>3</sup> A more general analysis therefore needs to be derived in order to evaluate the total radiation pattern variations as a function of antenna spacing. The purpose of determining the maximum value of the variations rather than their exact nature is that these maxima may be used as possible measurement accuracy limits.

Relating these limits to any antenna requires that a common reference level be established. A plane wave illumination of the system antenna would be required to obtain a pattern completely independent of separation. Since plane wave illumination requires an infinite separation, deviation between patterns taken at any particular separation and that taken at an infinite separation may be considered as an error of the true far field pattern. Although the maximum error would occur where the minimum energy level must be measured or discriminated from zero (i. e. , in the absolute pattern's nulls) it is much less cumbersome to refer all the energy levels to the maximum or main beam value as in a relative pattern. In this way a minimum level below the main beam reference can be established below which the measured pattern differs from the theoretical plane wave pattern, thus defining a maximum measurement dynamic range rather than an error magnitude for various antenna separations.

An example of this procedure may be seen from the hypothetical antenna pattern plot<sup>4</sup> shown in Figure 17.. In this figure the solid curve represents the pattern for a plane wave illumination with an infinite antenna separation, while the dashed curve and the dotted curve represent the same antenna's pattern at successively shorter separations. These patterns indicate that as the separation distance is decreased the lobes are slightly broadened and the nulls are considerably shallower.

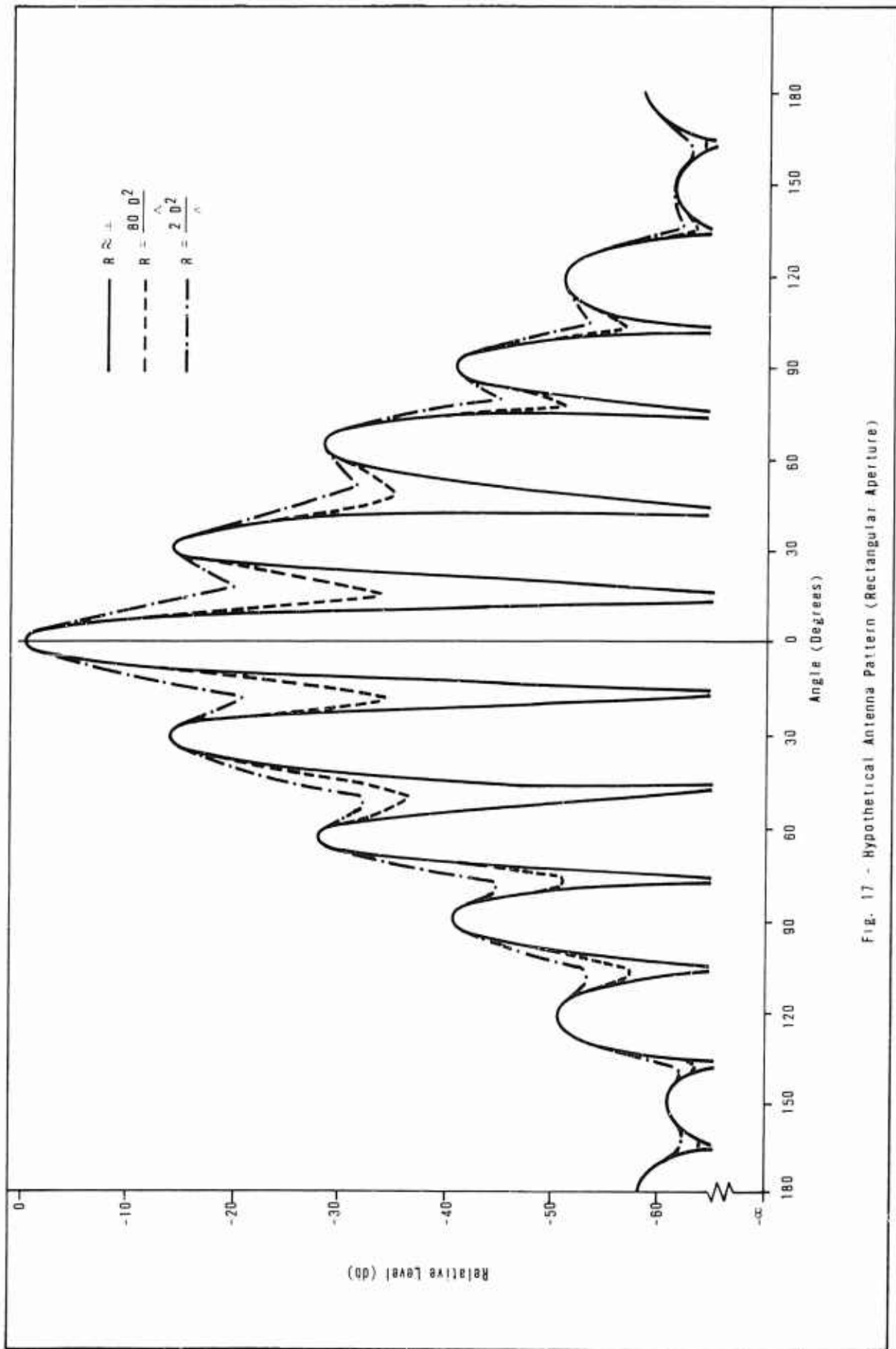

Fig. 17 - Hypothetical Antenna Pattern (Rectangular Aperture)

To obtain specific limits to the dynamic range of the far field pattern as a function of measuring distance with given values of the antenna aperture and wavelength, the shape of the antenna aperture must also be considered. In Figure 18, which shows theoretical patterns for circular and square apertures illuminated by a plane wave, it may be seen that the null depth in both patterns is theoretically at infinity. The lobe structure is sharper for the square aperture, with side lobe levels below those for the circular aperture. Comparing Figure 18 with Figure 17 (the solid curve), which is for a rectangular aperture with an 8 to 1 length to width ratio, shows that the rectangular aperture pattern has lower side lobes than either the circular or square aperture pattern .

From these theoretical patterns then it would seem that a conservative yet reasonably simple aperture shape to choose for analysis would be of rectangular form with a relatively large length to width ratio. For an aperture of this shape the errors resulting from inadequate spacing will be more pronounced than those for a circular or square shape since the maximum dynamic range of these shape patterns would be somewhat smaller. The results from the rectangular aperture will then serve to place minimum range limit on any simple aperture shape.

The method of this analysis will be to calculate the level of the radiation field at the position of the first null relative to the level of the main beam and relate this value to the aperture illumination. This aperture illumination may then be related to the spacing between the source and receiving antennas.

A general solution of the vector wave equations (derived from the basic electromagnetic field equations of Maxwell, Stratton<sup>5</sup> and others<sup>6</sup>) shows that the value of the radiation field at a point beyond the aperture of an antenna may be found by integrating the equivalent space current densities over the aperture itself. This is basically an application of Huygens' principle.<sup>4</sup> In a single plane the integral equation would simply be:

$$P = \int_{z^1}^{z^2} f(z) \frac{e^{-j\beta R}}{R} dz \quad (4)$$

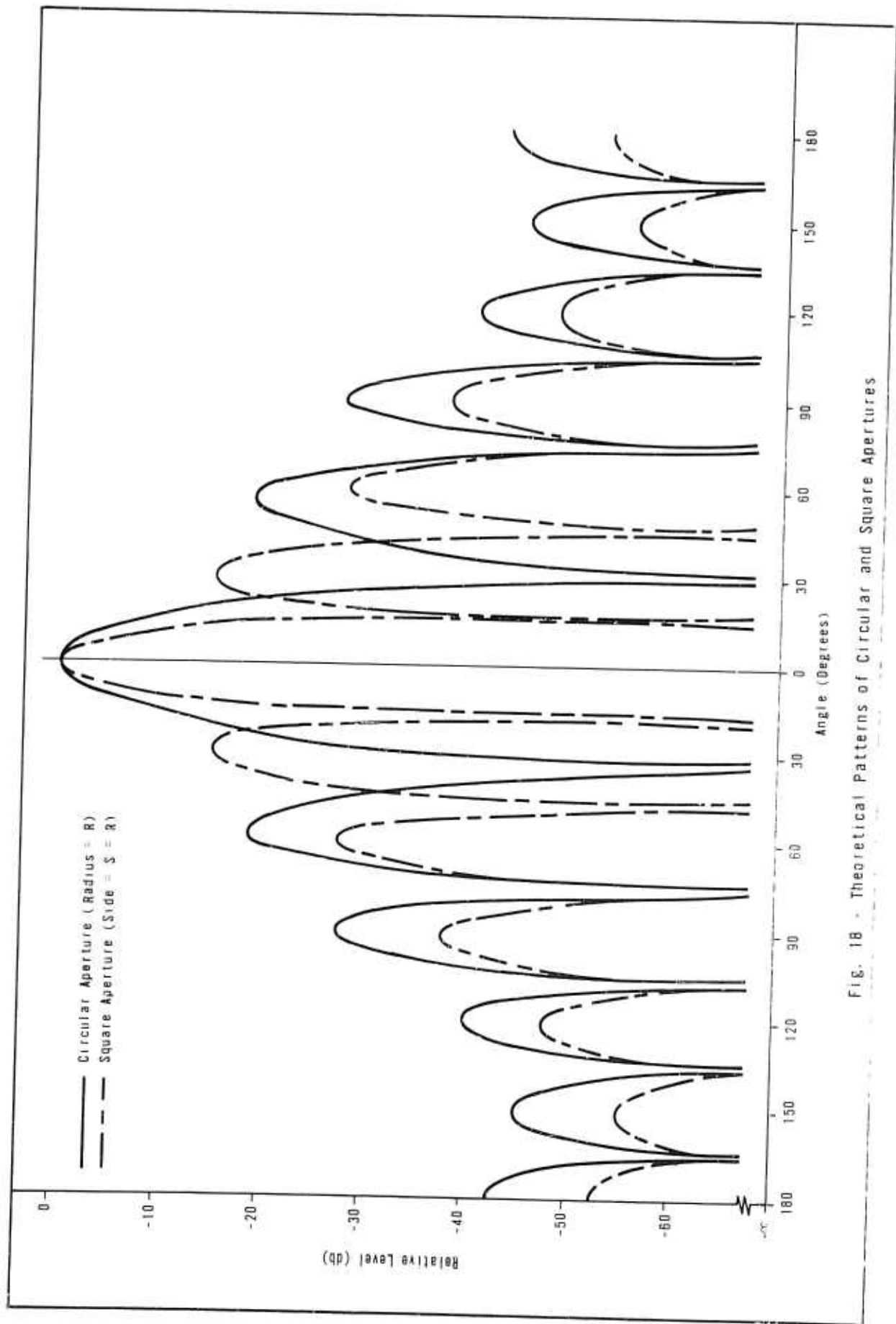

Fig. 18 - Theoretical Patterns of Circular and Square Apertures

where P is the field strength at a point p

R is the distance from each equivalent current increment  
on the aperture to point p

f(z) is the amplitude distribution across the aperture

$z_1$  and  $z_2$  are the physical limits of the aperture

Since the variation from a true far field pattern may result from either a phase variation or an amplitude variation over the illuminated aperture, the effect of the test antenna's aperture must be considered when the antenna spacing is not infinite. If the test antenna has a very small aperture, such as a point source, the amplitude distribution across the system antenna aperture would be essentially constant with separation; however, the phase difference across the aperture would increase as the separation was decreased. Also, if the test antenna has a very large aperture with respect to the system antenna, the amplitude distribution across the system antenna aperture would vary with the antenna separation distance due to the directivity of the test antenna, while the phase distribution would be almost constant.<sup>7</sup>

For strictly a phase variation over the system antenna a criterion of  $\lambda/16$  would establish a spacing as shown in equation (2) and would approximately equal the measurement error due to an amplitude variation<sup>8</sup> of  $(D + d)^2 / \lambda$ , where D is the systems antenna aperture and d is the test antenna aperture. If the power measurement error is permitted to be .25 db then the separation distance of equation (2) becomes one-half that for a phase error of  $\lambda/16$  and corresponds to a phase error of  $\lambda/8$ . This separation distance can now be derived from Figure 19.

$$\begin{aligned}(R + \lambda/8)^2 &= (D/2 + d/2)^2 + R^2 \\ R^2 + 2R \lambda/8 + (\lambda/8)^2 &= \frac{1}{4}(D + d)^2 \\ 2R \lambda/8 &= \frac{1}{4}(D + d)^2 \quad (\lambda/8)^2 \ll \lambda/8 \\ R &\geq \frac{(D + d)^2}{\lambda}\end{aligned}$$

If d is larger than 0.414D the maximum error is determined by the amplitude variation over the systems aperture, while if d is smaller than 0.414D the maximum

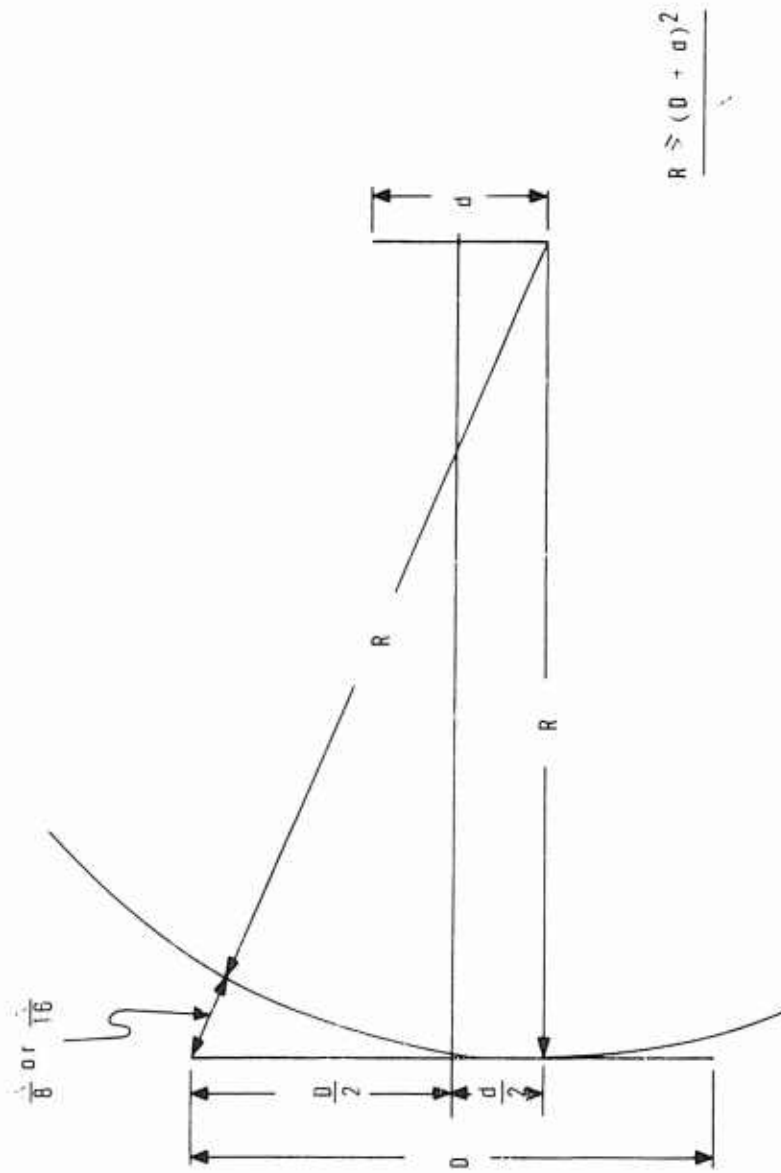

Fig. 19 - Maximum Phase Variation (Line Source)

error is determined by the phase variation. In any case these conditions may be looked upon as a limit to the antenna aperture dimensions rather than the limit to the minimum spacing.

Thus by judiciously selecting a test antenna with an aperture much less than  $0.414D$  it would be possible to retain only the phase term in the integrand of equation (4) with reasonable results. If  $R_0$  is taken as the antenna separation distance and  $\alpha$  is the acute angle between the antenna axis and the radius to the first null position the system geometry can be drawn as shown in Figure 20. From this geometry  $R$  may be written as:

$$R = R_0 \sqrt{1 + \frac{z^2}{R_0^2} - 2 \frac{z}{R_0} \sin \alpha}$$

$$R = R_0 \left[ 1 + \frac{z^2}{2R_0^2} - \frac{z}{R_0} \sin \alpha - \frac{1}{4} \left( \frac{z^2}{R_0^2} - 2 \frac{z}{R_0} \sin \alpha \right)^2 + \dots \right] \quad (5)$$

The series in equation (5) is the binomial expansion of the square root. This is a series in powers of

$$\left( \frac{z^2}{R_0^2} - \frac{2z}{R_0} \sin \alpha \right).$$

Since it is alternating and the  $n$ th term approaches zero, the error incurred by dropping the terms involved in the square of this quantity and higher powers is no greater than the first term discarded. Therefore,

$$R = R_0 + \frac{z^2}{2R_0} - z \sin \alpha + \epsilon \quad (6)$$

where the error  $\epsilon$  satisfies

$$|\epsilon| < \frac{R_0}{4} \left( \frac{z^2}{R_0^2} - 2 \frac{z}{R_0} \sin \alpha \right)^2 \quad (7)$$

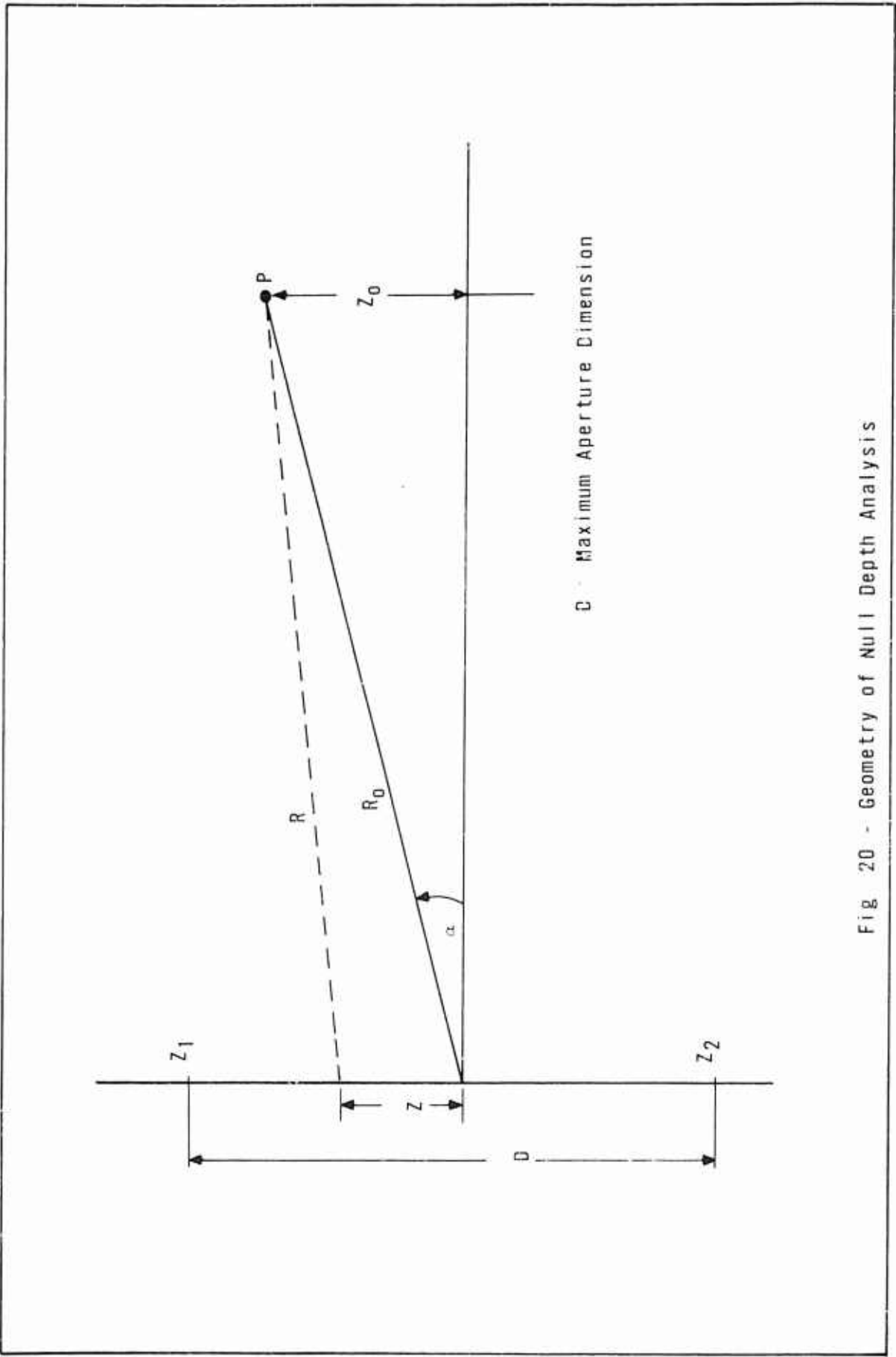

Fig 20 - Geometry of Null Depth Analysis

Using only the first three terms of the series expansion of equation (5), the phase term of equation (4) may be written as:

$$\beta R = \beta R_o + \beta \left( \frac{z^2}{2 R_o} - z \sin \alpha \right) \quad (8)$$

The error incurred by dropping the rest of the terms of this series would be no greater than that given in equation (7) or

$$|\beta \epsilon| < \frac{\beta R_o}{4} \left( \frac{z^2}{R_o^2} - 2 \frac{z}{R_o} \sin \alpha \right)^2 \quad (9)$$

This error would be a maximum when  $\alpha = \frac{\pi}{2}$  and  $Z = -\frac{D}{2}$ . Hence,

$$|\beta \epsilon|_{\max} = \frac{\beta R_o}{4} \left( \frac{D^2}{4 R_o^2} + \frac{D}{R_o} \right)^2 \quad (10)$$

For reasonably directive antennas at moderate ranges, the magnitude of this error is quite small. For example, if  $D = 20 \lambda$  and  $R_o = 80 D$

$$|\beta \epsilon|_{\max} = \frac{\pi}{8}$$

Also, since maximum error would occur at  $\alpha = \frac{\pi}{2}$  or  $90^\circ$  from the main axis the error over most of the pattern would be negligible. On this basis, then equation (4) may be written with the phase terms of equation (8) or

$$u = e \frac{e^{-j\beta R_o}}{R_o} \int_{-\frac{D}{2}}^{\frac{D}{2}} e^{-j\beta \left( \frac{z^2}{2R_o} - z \sin \alpha \right)} dz \quad (11)$$

using a change of variables of

$$\frac{\beta}{2R_o} (z - R_o \sin \alpha)^2 = \frac{\pi}{2} S^2 \quad (12)$$

the following manipulations may be performed.

From equation (12)

$$S = \sqrt{\frac{\lambda}{\pi} \frac{\beta}{2R_0}} (z - R_0 \sin \alpha) = \sqrt{\frac{\beta}{R_0 \pi}} (z - R_0 \sin \alpha) \quad (13)$$

and since

$$\beta = \frac{\lambda \pi}{\lambda} \quad (14)$$

then

$$S = \sqrt{\frac{\lambda}{R_0 \lambda}} (z - R_0 \sin \alpha) = \sqrt{\frac{\lambda}{R_0 \lambda}} (z - R_0 \sin \alpha) \quad (15)$$

The value of the differential will equal

$$ds = \sqrt{\frac{\lambda}{R_0 \lambda}} dz \quad \text{or} \quad dz = \sqrt{\frac{R_0 \lambda}{\lambda}} ds \quad (16)$$

The variable exchange in the exponent of the integrand of equation (11) may be effected by first expanding equation (10) as

$$\begin{aligned} \frac{\pi}{2} s^2 &= \frac{\beta}{2R_0} (z - R_0 \sin \alpha)^2 = \frac{\beta}{2R_0} (z^2 - 2z R_0 \sin \alpha + R_0^2 \sin^2 \alpha) \\ \frac{\pi}{2} s^2 &= \beta \left( \frac{z^2}{2R_0} - z \sin \alpha + \frac{R_0}{2} \sin^2 \alpha \right) \end{aligned} \quad (17)$$

To equate the exchange variable to the exponent then the constant term

$\frac{R_0}{2} \sin^2 \alpha$  must be subtracted. That is

$$\begin{aligned} \beta \left( \frac{z^2}{2R_0} - z \sin \alpha \right) &= \beta \left( \frac{z^2}{2R_0} - z \sin \alpha + \frac{R_0}{2} \sin^2 \alpha \right) \\ - \frac{\beta R_0}{2} \sin^2 \alpha &= \frac{\pi}{2} s^2 - \frac{\beta R_0}{2} \sin^2 \alpha \end{aligned} \quad (18)$$

Using equations (16) and (18) the entire integrand of equation (11) may be re-written in terms of the variable S as

$$e^{-j\beta} \left( \frac{z^2}{2R_o} - z \sin \alpha \right) dz = \sqrt{\frac{R_o \lambda}{2}} e^{-j} \left( \frac{\pi}{2} S^2 - \frac{\beta R_o}{2} \sin^2 \alpha \right) ds$$

or

$$e^{-j\beta} \left( \frac{z^2}{2R_o} - z \sin \alpha \right) dz = \sqrt{\frac{R_o \lambda}{2}} \left[ e^{+j} \frac{\beta R_o}{2} \sin^2 \alpha e^{-j} \frac{\pi}{2} S^2 \right] ds \quad (19)$$

Removing the first two factors from under the integral sign would then allow equation (11) to be written as

$$u = \frac{e^{-j\beta R_o}}{R_o} \sqrt{\frac{R_o \lambda}{2}} e^{+j\beta R_o} \sin^2 \alpha \int e^{-j} \frac{\pi}{2} S^2 ds \quad (20)$$

or combining the exponent

$$u = \sqrt{\frac{R_o \lambda}{2}} \frac{e^{-j\beta R_o}}{R_o} \left( 1 - \frac{\sin^2 \alpha}{2} \right) \int_{S_1}^{S_2} e^{-j} \frac{\pi}{2} S^2 ds \quad (21)$$

The values of the limits of the integral must also be obtained in terms of the exchange variable S. Since from equation (14)

$$S_1 = \sqrt{\frac{2}{R_o \lambda}} (z_1 - R_o \sin \alpha)$$

then where  $z_1 = -\frac{D}{2}$

$$S_1 = \sqrt{\frac{2}{R_o \lambda}} \left( -\frac{D}{2} - R_o \sin \alpha \right) = -\sqrt{\frac{2}{R_o \lambda}} \left( R_o \sin \alpha + \frac{D}{2} \right) \quad (22)$$

and where  $z_2 = \frac{D}{2}$

$$S_2 = \sqrt{\frac{2}{R_0 \lambda}} \left( \frac{D}{2} - R_0 \sin \alpha \right) = \sqrt{\frac{2}{R_0 \lambda}} \left( R_0 \sin \alpha - \frac{D}{2} \right) \quad (23)$$

From the right triangle shown in the geometry of Figure 20  $z_0$  may be written as

$$z_0 = R_0 \sin \alpha \quad (24)$$

and upon substitution of this value in equations (22) and (23) the resulting values of the limits are then obtained as:

$$S_1 = \sqrt{\frac{2}{R_0 \lambda}} \left[ z_0 + \frac{D}{2} \right] \quad (25)$$

$$S_2 = \sqrt{\frac{2}{R_0 \lambda}} \left[ z_0 - \frac{D}{2} \right] \quad (26)$$

The integral of equation (21) is the Fresnel integral with values tabulated in various texts such as those on physical optics.<sup>9</sup> Although these integrals show side lobe maxima that are substantially unaffected by range, they also show the minima fill in as  $R_0$  is decreased. The minimum affected most by the short range is the first one or the null between the main beam and the first side lobe. The ratio of the main beam to the first null level may then be calculated for various ranges. The ratio of the main beam level to the first null level may be expressed in decibels as

$$(\text{db}) = 20 \log_{10} \frac{e^{-j\beta R_0} \left( 1 - \frac{\sin \alpha}{2} \right) \int_{S_1'}^{S_2'} e^{-j \frac{\pi}{2} S^2} ds}{e^{-j\beta R_0} \left( 1 - \frac{\sin^2 \alpha}{2} \right) \int_{S_1''}^{S_2''} e^{-j \frac{\pi}{2} S^2} ds} \quad (27)$$

For relatively directive antennas where the angle from the main beam to the first null is quite small, i. e.,  $a$  is small, then the ratio will be essentially the ratio of the value of the integral obtained for the main beam to the value of the integral for the first null or

$$(db) = 20 \log_{10} \frac{\int_{S_1'}^{S_2'} e^{-j \frac{\pi}{2} S^2} ds}{\int_{S_1''}^{S_2''} e^{-j \frac{\pi}{2} S^2} ds} \quad (28)$$

where  $S_2''$  and  $S_1''$  are the limits at the first null or

$$S_2'' = -\sqrt{\frac{2}{R_0 \lambda}} \left( z_0 - \frac{D}{2} \right)$$

$$S_1'' = -\sqrt{\frac{2}{R_0 \lambda}} \left( z_0 + \frac{D}{2} \right)$$

As per equations (25) and (26) and  $S_2'$  and  $S_1'$  are the limits at the main beam where  $z_0 = 0$  or

$$S_2' = \sqrt{\frac{2}{R_0 \lambda}} \left( \frac{D}{2} \right)$$

$$S_1' = -\sqrt{\frac{2}{R_0 \lambda}} \left( \frac{D}{2} \right)$$

In order to relate these results to the normalized values of the aperture size in wavelengths the minimum range could be expressed as a constant "a" times the range criterion of equation (2) or

$$R_0 = a \frac{2D^2}{\lambda} \quad (29)$$

where "a" may be treated as a parameter that could vary from less than one to values greater than one. The limits of the integral in equation (28) could then be written in terms of the parameter  $\underline{a}$  as:

$$S_1' = -\frac{1}{2} \frac{1}{\sqrt{a}}$$

$$S_2' = \frac{1}{2} \frac{1}{\sqrt{a}}$$

$$S_1'' = -\sqrt{\frac{2}{R_0 \lambda}} z_0 - \frac{1}{2\sqrt{a}}$$

$$S_2'' = -\sqrt{\frac{2}{R_0 \lambda}} z_0 + \frac{1}{2\sqrt{a}}$$

where

$$S_2' - S_1' = S_2'' - S_1'' = \frac{1}{\sqrt{a}}$$

Therefore, for a particular value of "a" the difference between the two sets of limits of the integrals would be the same. From a set of integral tables the values of the integral were plotted on a large scale graph forming the familiar Cornu's spiral. A graphical solution of the integrals was obtained by using a set of dividers to locate the first nulls for each specific value of the limit difference corresponding to the selected value of "a." For example for  $a = 1$ ,  $S_2' - S_1' = S_2'' - S_1'' = 1$  and from the graph the first minimum occurred for  $S_2'' = 2.5$  and  $S_1'' = 1.5$  and the value of the integral = 0.08. Also on the main beam  $S_2' = 0.5$  and  $S_1' = -0.5$  and the value of the integral = 0.99. Then from equation (28)

$$20 \log_{10} \frac{0.99}{0.08} = 22 \text{ db}$$

From these calculations a graph could be plotted as shown in Figure 21 for the level of the first null below the main beam in decibels as function of the parameter "a." The criterion of  $2D_2/\lambda$  for a minimum antenna spacing is quite reasonable. Each decibel of dynamic range beyond this point becomes more and more expensive in terms of separation distance. Except for certain antennas

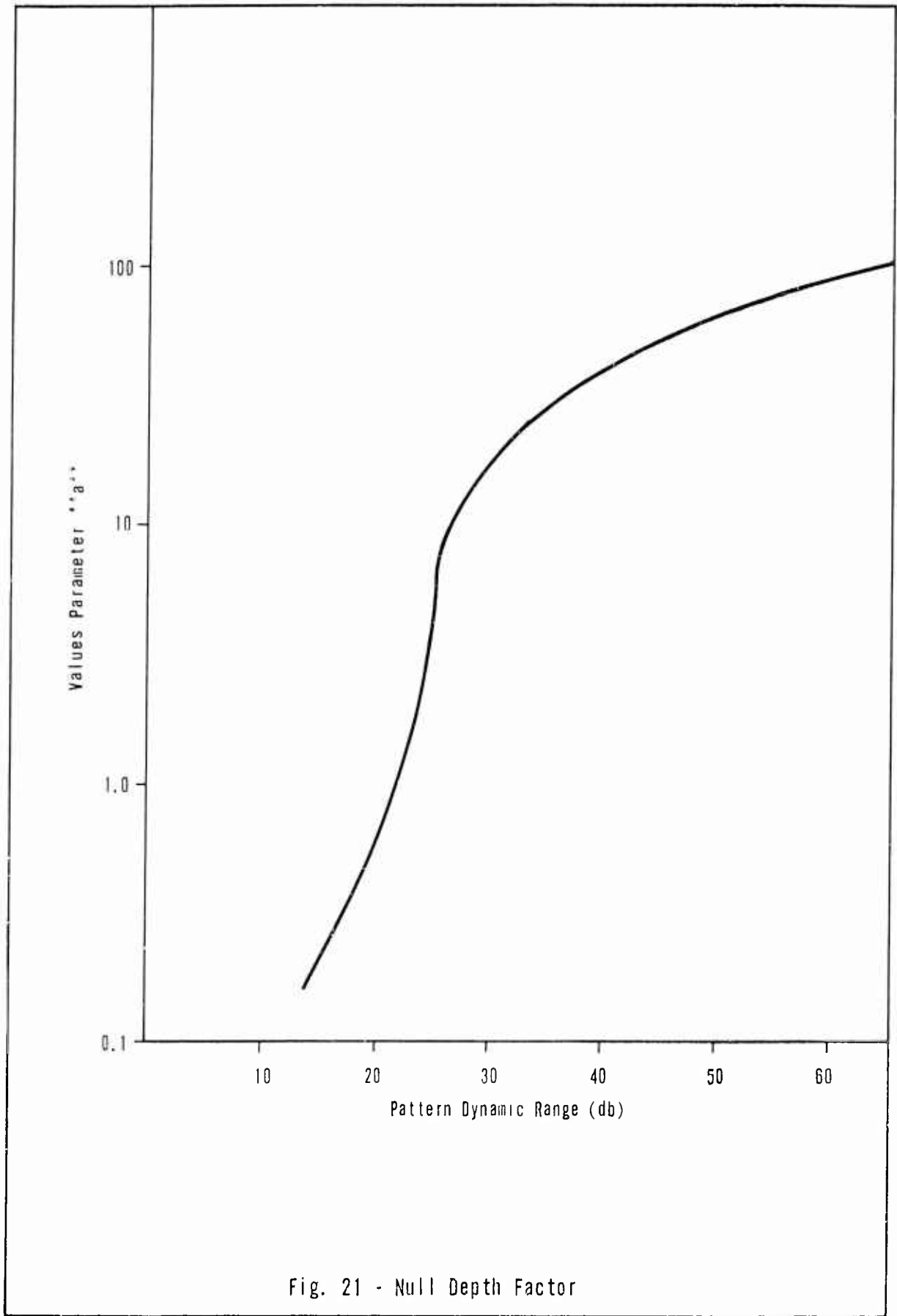

Fig. 21 - Null Depth Factor

which are intentionally focused for a particular distance, as the directivity of an antenna pattern is increased, the validity of the measurement is more dependent on the system and test antenna separation. In practice then the dynamic range of a true far field pattern measurement may be increased simply by increasing the dynamic range of the recording equipment.

When measurements are conducted on the surface of the earth a number of other factors, not the least of which is the ground itself, may affect the pattern. These factors will be considered in the following chapters.

CHAPTER III  
THE GROUND REFLECTION TEST RANGE

A. THE TECHNIQUE

Antenna testing must be performed so that certain illumination requirements are satisfied for the antenna whose pattern is being measured. The Fraunhofer criterion determines the minimum range length that will provide the requisite phase and amplitude tolerance in free space. When such testing is done over the surface of the earth the effects of the ground must be considered. This can lead to techniques that attempt to minimize ground effects, control them or both. The "high level" range attempts to eliminate the ground by placing the transmitting and receiving antennas at a high level above the intervening terrain, and using a transmitting antenna with a null that can be directed at the point of maximum reflection on the ground. RADC already has such a range which has proven to be of limited utility for a number of reasons.

The reflection range design<sup>10</sup> attempts to make use of the ground by a controlled utilization of the reflection. It can be seen from Figure 22 that if the ground is sufficiently flat the energy arriving at the receiver is composed of a direct ray from the transmitter and a reflected ray from the ground or transmitter image. The direct and ground-reflected rays combine to produce a well-defined interference pattern in the plane of the receiver antenna with a null at the ground and successive peaks and nulls with increasing height. The region around a peak value of this pattern may be used in testing an antenna. The maximum useful size of the region may be determined from the phase and amplitude tolerances allowed.

Of course, one of the major problems in the design of such a range is to provide a sufficiently flat dielectric surface. When grazing angles are involved (on the order of  $3^\circ$  or less) then the magnitude and phase of the reflection coefficients are very nearly unity and  $180^\circ$  respectively relative to the direct ray for both horizontal and vertical polarization. The smoothness required will be considered elsewhere.

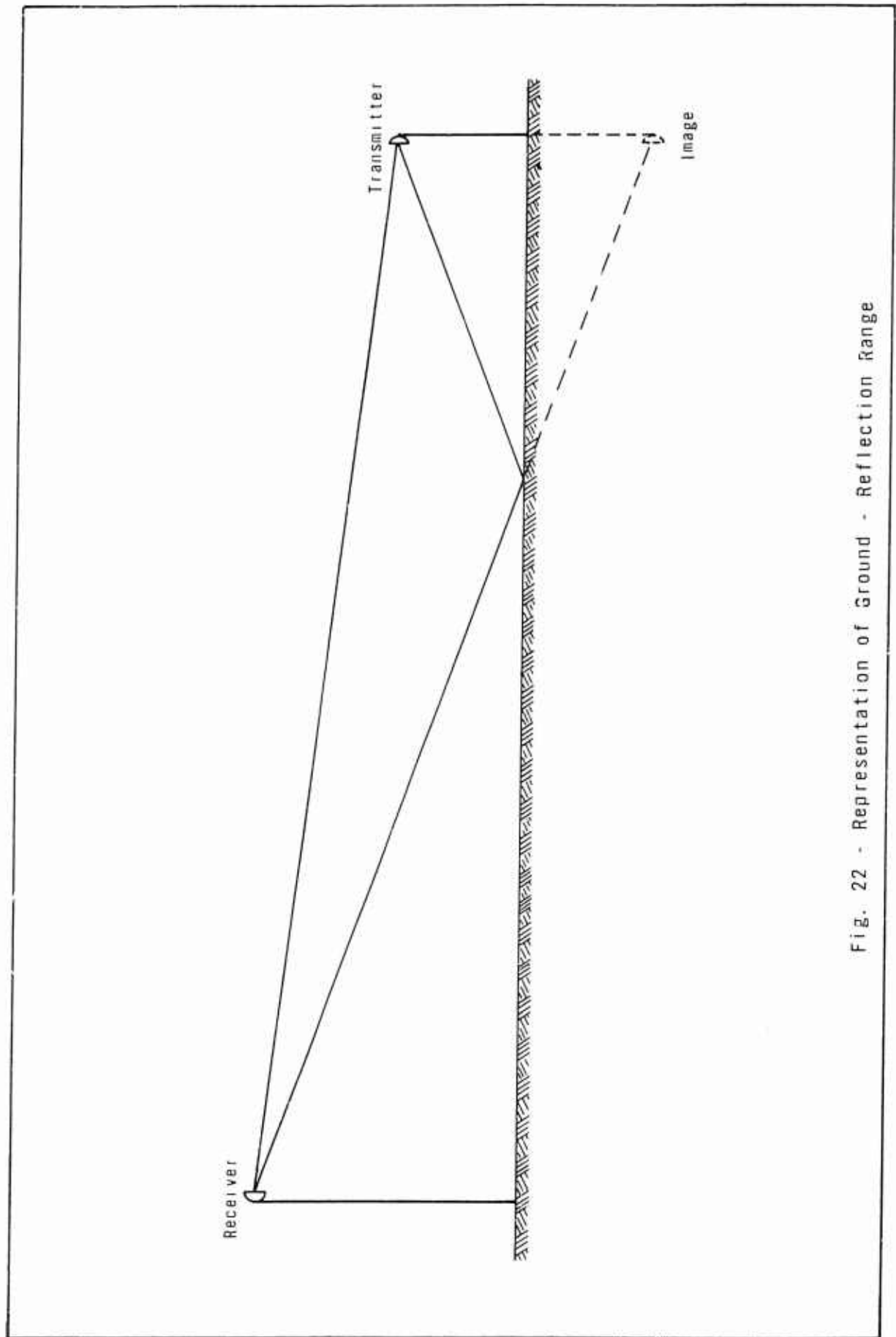

Fig. 22 - Representation of Ground - Reflection Range

## B. CALCULATION OF THE VERTICAL FIELD

For proper operation of the range the antenna under test must be located on a maxima of the interference pattern and the maximum vertical dimension of the aperture must be limited to a region where the illumination amplitude and phase are within allowable limits.

Consider the total amplitude,  $E_s$ , made up of the direct ray,  $\rho$ , as indicated in Figure 23. The phase angle between the direct and reflected ray is  $\psi$ .

$$\begin{aligned} \psi &= 2\pi \times \text{path difference in wavelengths, } k \\ &= 2\pi \frac{\Delta p}{\lambda} = 2\pi k \end{aligned} \quad (1)$$

Then by the law of cosines:

$$\begin{aligned} E_s &= \sqrt{1 + \rho^2 - 2\rho \cos(\pi - \psi)} \\ &= \sqrt{1 + \rho^2 + 2\rho \cos \psi} \end{aligned} \quad (2)$$

From Figure 24 the path length difference in wavelengths is

$$k = \frac{1}{\lambda} (p_2 + p_3 - p_1)$$

The path lengths are:

$$p_1 = \sqrt{R^2 + (z + H_t)^2} \quad (3)$$

$$p_2 = \sqrt{z^2 + x_o^2} \quad (4)$$

Since the angle of incidence equals the angle of reflection:

$$\frac{p_2}{p_3} = \frac{z}{H_t} = \frac{x_o}{R - x_o}$$

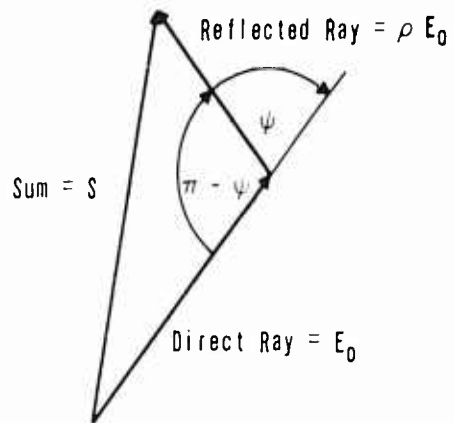

$$S^2 = 1 + \rho^2 - 2\rho \cos(\pi - \psi)$$

$$E_c = E_0 \sqrt{1 + \rho^2 + 2\rho \cos \psi}$$

$$S = \frac{E_c}{E_0} = \sqrt{1 + \rho^2 + 2\rho \cos \psi}$$

Fig. 23 - Total Amplitude

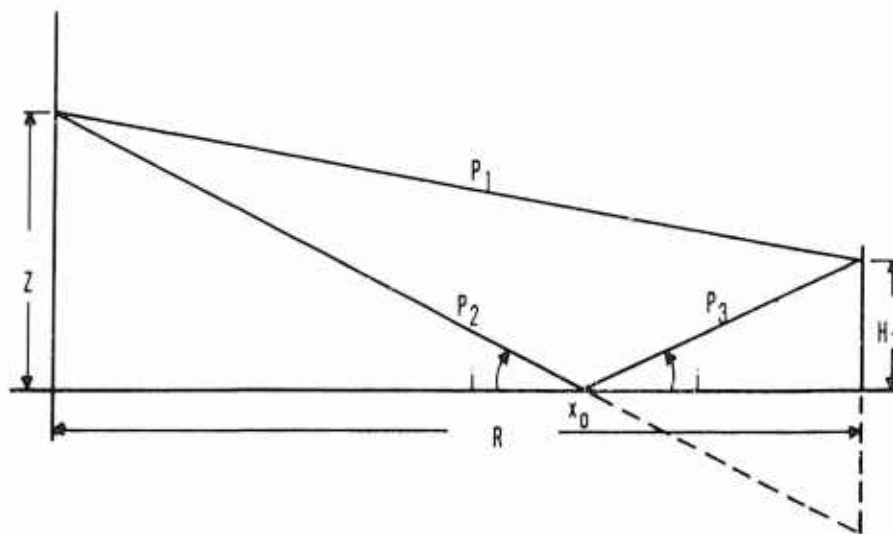

Fig. 24 - Reflection Geometry

therefore,

$$p^3 = \frac{H_t}{z} p^2 \quad (5)$$

and

$$\frac{H_t}{z} = \frac{R - x_o}{x_o}$$

whereby

$$x_o = \frac{zR}{z + H_t}$$

therefore:

$$p_2 \left( \frac{H_t}{z} + 1 \right) - p_1 = k\lambda$$

and from (3) and (4):

$$\sqrt{z^2 + x_o^2} \left( \frac{z + H_t}{z} \right) - \sqrt{R^2 + (z - H_t)^2} = k\lambda$$

Substituting (6) and extracting  $z$  to obtain the solution in terms of elevation:

$$z \sqrt{1 + \frac{R^2}{(z + H_t)^2}} \left( \frac{z + H_t}{z} \right) - \sqrt{R^2 + (z - H_t)^2} = k\lambda$$

$$\frac{z}{z + H_t} \sqrt{(z + H_t)^2 + R^2} \left( \frac{z + H_t}{z} \right) - \sqrt{(z - H_t)^2 + R^2} = k\lambda$$

$$\sqrt{z^2 + H_t^2 + R^2 + 2zH_t} - \sqrt{z^2 + H_t^2 + R^2 - 2zH_t} = k\lambda$$

Let  $z^2 + H_t^2 + R^2 = a, \quad 2zH_t = b \quad (7, 8)$

$$\sqrt{a + b} - \sqrt{a - b} = k\lambda$$

Squaring:

$$(a + b) + (a - b) - 2 \sqrt{(a + b)(a - b)} = (k\lambda)^2$$

$$\sqrt{a^2 - b^2} = a - 1/2 (k\lambda)^2$$

Squaring:

$$a - \frac{b^2}{(k\lambda)^2} = 1/4 (k\lambda)^2$$

Returning to the original variables from (7, 8):

$$z^2 + H_t^2 + R^2 - \frac{4z^2 H_t^2}{(k\lambda)^2} = 1/4 (k\lambda)^2$$

$$z^2 \left(1 - \frac{4H_t^2}{(k\lambda)^2}\right) = 1/4 (k\lambda)^2 - H_t^2 - R^2$$

$$z^2 = (k\lambda)^2 \frac{R^2 + H_t^2 - 1/4 (k\lambda)^2}{4H_t^2 - (k\lambda)^2}$$

$$z = k\lambda \sqrt{\frac{R^2 + H_t^2 - 1/4 (k\lambda)^2}{4H_t^2 - (k\lambda)^2}} \quad (9)$$

Since for the frequency range of interest here,  $R^2 \gg H_t^2 \gg (k\lambda)^2$ :

$$z = \frac{k\lambda R}{2H_t}$$

$$k = \frac{2z H_t}{\lambda R} \quad (10)$$

From equations (1) and (10)

$$\psi = \frac{4\pi z H_t}{\lambda R} \quad (11)$$

Since  $|\rho| \leq 1$ ,  $E_s$  will take on values  $0 \leq E_s \leq 2$  as  $\psi$  takes on all values.  $E_{s \max}$  for negative values of  $\rho$  will occur at:

$$\psi = \pi, 3\pi, 5\pi, \text{ etc.}$$

$$\psi = n\pi \quad n \text{ odd}$$

and for positive values of  $\rho$  at:

$$\psi = 0, 2\pi, 4\pi, \text{ etc.}$$

$$\psi = n\pi \quad n \text{ even}$$

By definition at  $E_{s \max}$ ,  $z = H_R$ . So

$$\psi = \frac{4\pi H_t H_R}{\lambda R} = n\pi$$

$$4H_t H_R = n \lambda R \quad (12)$$

$E_s$  may then be expressed as:

$$E_s = \sqrt{1 + \rho^2 + 2\rho \cos n\pi \frac{z}{H_R}} \quad (13)$$

and

$$\psi = \frac{n\pi}{H_R} z \quad (14)$$

When  $\rho = -1$

$$E_s = \sqrt{2(1 - \cos \psi)} = \bar{\pm} 2 \sin \frac{\psi}{2} = \bar{\pm} 2 \sin \frac{n\pi}{2H_R} z$$

$$n = 1, 3, 5, \text{ etc.}$$

The pattern is sinusoidal with nulls at the ground and at multiples of  $2H_R$ . Figure 25 shows these patterns for the case where  $H_R$  is physically constrained to the same value for  $n = 1$  and  $n = 3$ . It also shows how when  $\rho \neq -1$  the nulls fill in and the illumination becomes more uniform.

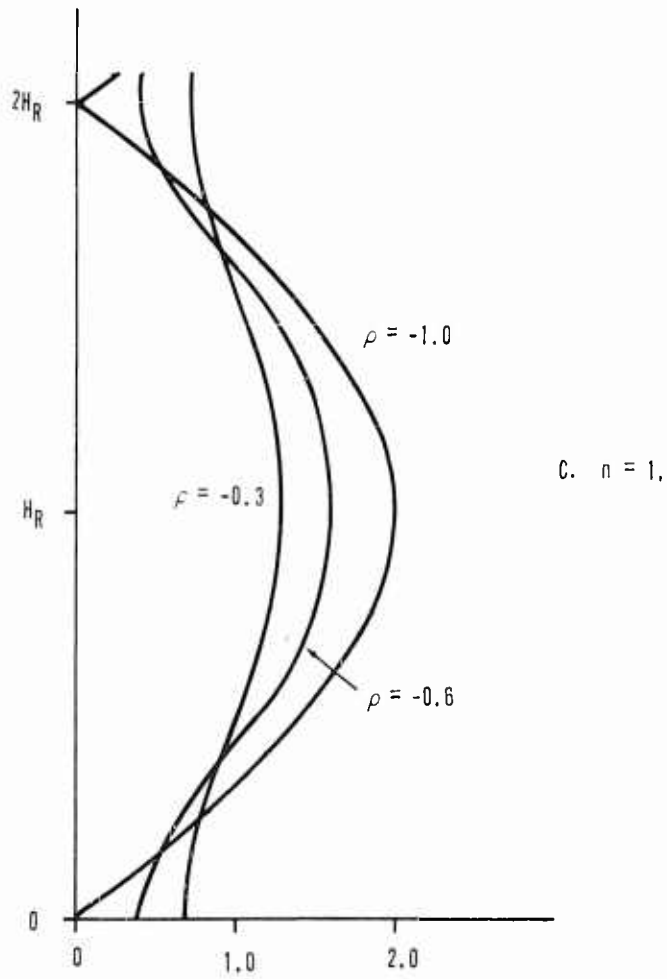
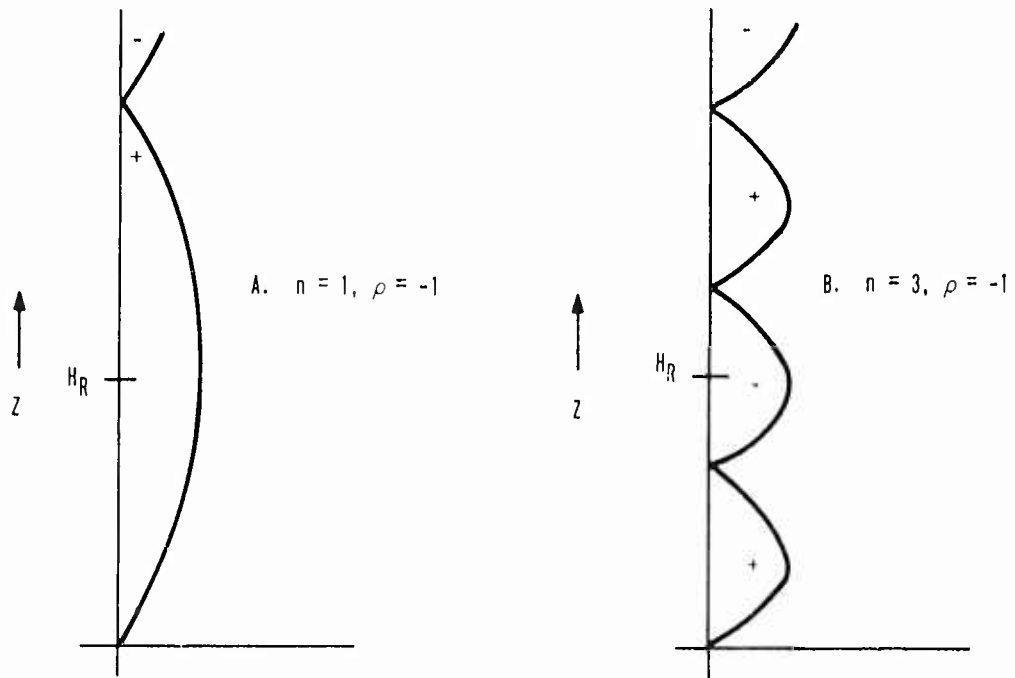

Fig. 25 - Variations in Amplitude of Illumination

The phase of this illumination is also of interest. Due to the finite distance between the transmitter and receiver antennas the phase front of the illuminating wave will not be a plane. Furthermore, the sum of the reflected and direct waves must be again considered. The point of phase reference is initially taken to be at ground level in the plane of the receiving antenna. The phase calculation of the wave resulting from the image and source radiation involves the difference in path lengths for the resultant wave at a given height and the resultant wave at the reference point.

The difference in path length for the direct and reflected ray has already been given in equation 10. This will allow the evaluation of the phase difference,  $\alpha$ , between the direct and resultant waves. In evaluating the phase along a vertical line at the receiver location, one must add to this the spherical divergence phase shift,  $2\pi x$ , of the direct wave with height,  $z$ . The quantity  $x$  is derived from:

$$\lambda x = \sqrt{(z - H_T)^2 + R^2} - R$$

When both  $z$  and  $H_T$  are very much smaller than  $R$ , this may be approximated as:

$$x = \frac{(z - H_T)^2}{2 \lambda R} \quad (15)$$

The phase angle  $\phi$  is the sum of these angles and becomes increasingly negative with  $z$ . One then has:

$$\phi = -(2 \pi x + \alpha) \quad (16)$$

where

$$\alpha = \arctan \left[ \frac{\rho \sin (2 \pi k)}{1 + \rho \cos (2 \pi k)} \right] \text{ from the trigonometric}$$

relations indicated in Figures 26a;

and

$$k = \frac{2 z H_T}{\lambda R} \text{ as given by equation (10).}$$

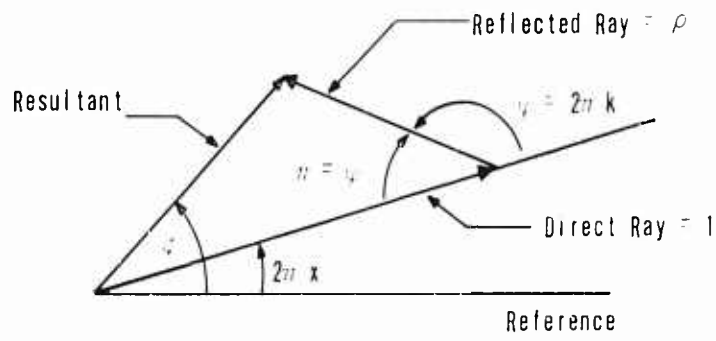

26a Phase Vector Diagram

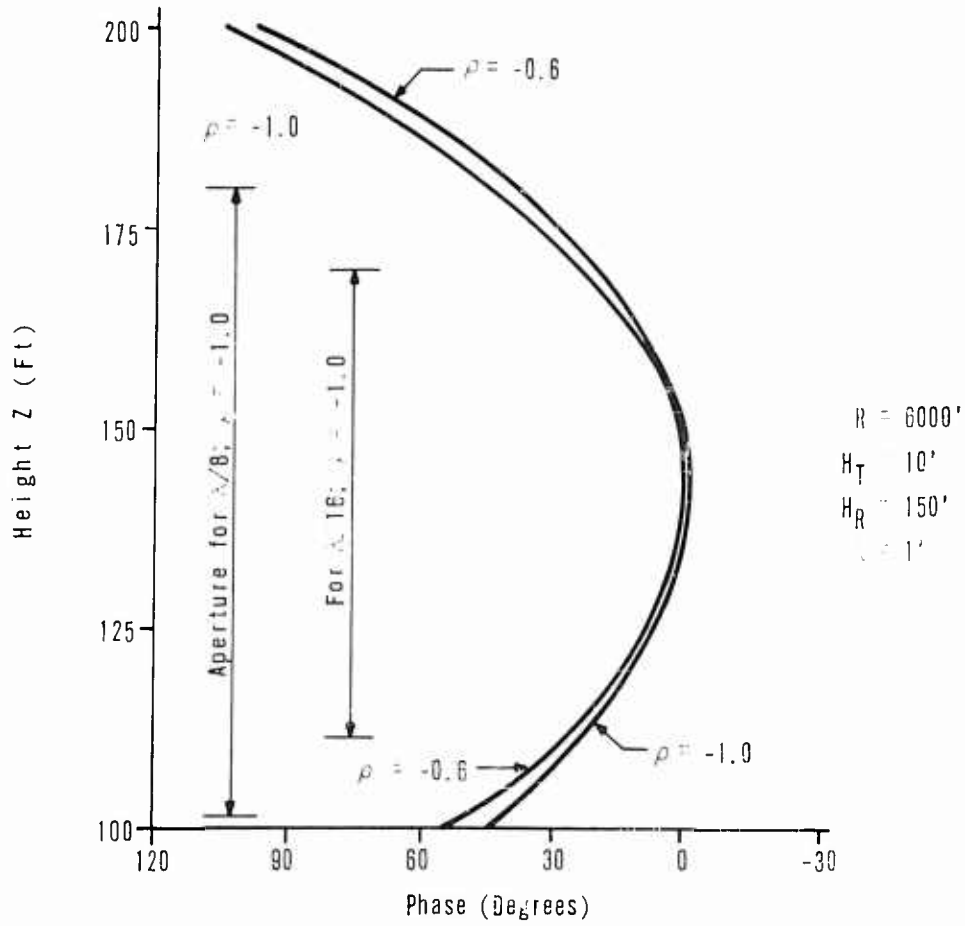

26b Plot of Equation 17

Fig. 26 - Variation in Phase Illumination

The term involving  $x$  leads to large, rapidly changing values of relative phase in the vicinity of the receiver antenna. The rate of change of relative phase at  $z = H_R$  will become zero if the rotational axis of the antenna is tilted towards the phase center of the radiation source. By re-defining the first term in (16) so that the phase angle is zero at  $z = H_R$ , the relation for the relative phase will be conveniently referenced to zero at the center of the receiver antenna aperture. The resulting relation is:

$$\phi_R = - \left[ \frac{(z - H_R)^2}{2 \lambda R} + \alpha \right] \quad (17)$$

This relation is plotted in Figure 26b for the parameters indicated.

It is seen that a region approximately 85 feet high has phase constancy within  $\lambda/8$ , and a region 60 feet high has a phase constancy of  $\lambda/16$  or better. At an antenna height of 120 feet a region very nearly 55 feet high will have a phase constancy of  $\lambda/16$ . The point of zero phase reference is not precisely at  $z = 150$  feet (or 120 feet for the case of the lower antenna because of the net effect of the angle  $\alpha$ ). Tilting the antenna will compensate for this, making the phase distribution indicated in Figure 26b nearly symmetrical about  $z = 150$  feet (or 120 feet). This tilting towards the phase center of the radiation source corresponds to pointing the antenna at the base of the transmitter tower when  $\rho = -1$  and somewhere between the base and the transmitting antenna itself when  $\rho$  lies between  $-1$  and zero.

The amplitude illumination will always be of the form of equation 13 when equation 12 is satisfied, i. e.,

$$4 H_T H_R = n \lambda R.$$

This provides the basic equation for the operation of a reflection range. A sample set of curves relating transmitter height to frequency is given in Figure 27. Testing may be performed at any range by suitable selection of transmitter height. When the height becomes too small operating in the  $n = 1$  mode, the height may be increased by using  $n = 3$ . However, it is apparent from Figure 25b that this will restrict the maximum receiving aperture.

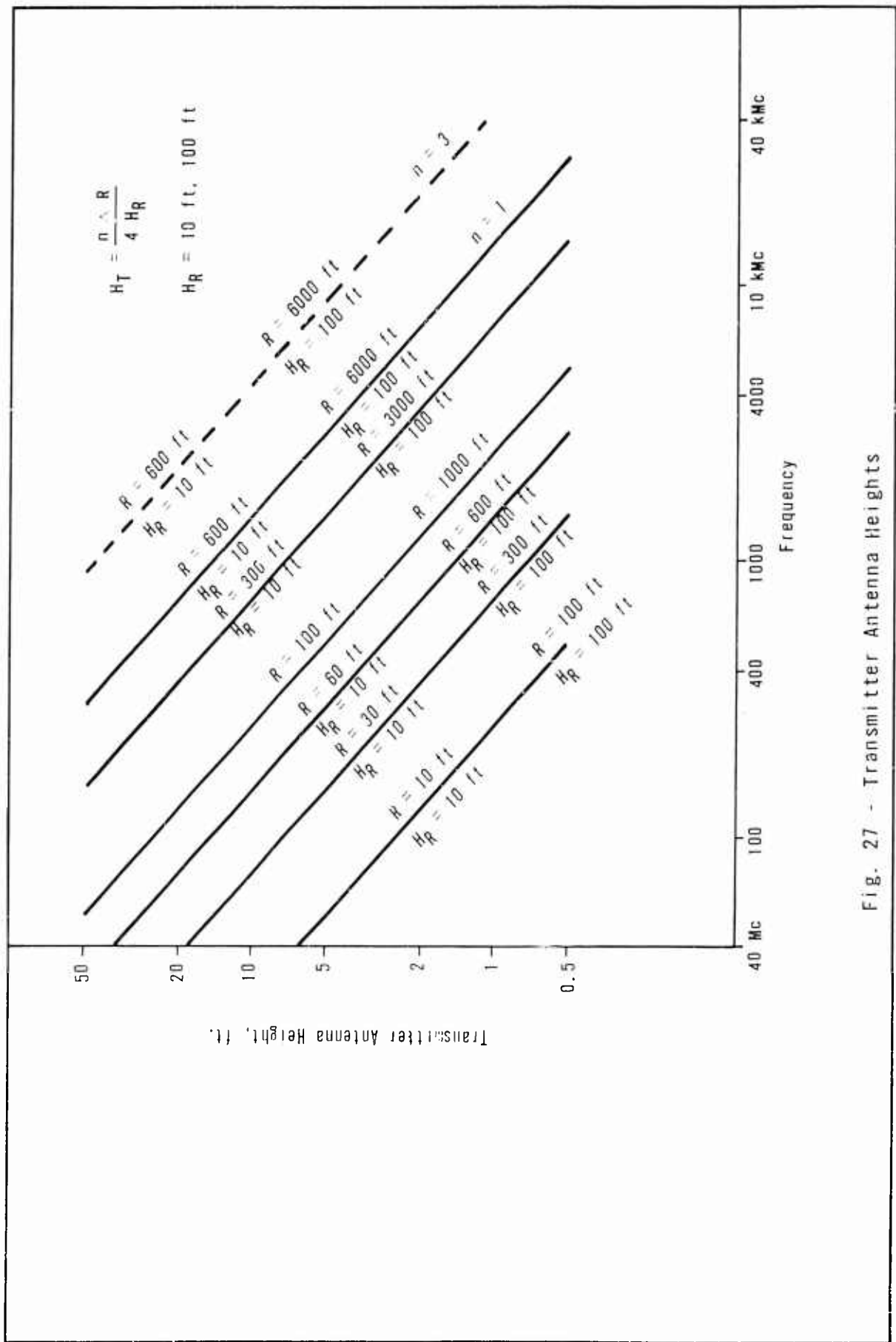

Fig. 27 - Transmitter Antenna Heights

### C. MAXIMUM APERTURE

In order to determine the maximum aperture that can be accommodated with a certain illumination tolerance, we must first determine for what value of  $z$  does  $E_s$  take on a certain (to be specified) value of  $E_s$  max:  $E_s = \chi E_0$

$$\chi E_0 = E_s = \pm \sqrt{1 + \rho^2 + 2\rho \cos \psi}$$

$$\chi^2 E_0^2 = 1 + \rho^2 + 2\rho \cos \psi$$

$$\psi = \arccos \left( \frac{\chi^2 E_0^2 - 1}{2\rho} - \frac{\rho}{2} \right)$$

Take  $\rho = -1$ , in which case  $E_0 = 2$ :

$$\psi = \arccos \left( \frac{4\psi^2 - 1}{-2} + \frac{1}{2} \right)$$

$$\psi = \arccos (1 - 2\psi^2)$$

For an illumination amplitude tolerance of  $\pm 1/4$  db, we are interested in the points  $z_1$  and  $z_2$ , where the illumination is down  $1/2$  db, or

$$\chi = 0.945$$

$$\psi = \arccos (1 - 240.891)$$

$$= \arccos (-0.782)$$

(Note that at  $E_0$ ,  $\psi = \pi$  and  $\cos \psi = -1$ )

$$\psi = 180^\circ \pm 38.6^\circ = 141.4^\circ \text{ and } 216.6^\circ$$

$$= .784\pi \text{ and } 1.20\pi \text{ radians}$$

$$z_1 = \frac{H_R}{\pi} (.784\pi) \quad z_2 = \frac{H_R}{\pi} (1.20\pi)$$

The maximum vertical aperture dimension for  $\pm 1/4$  db illumination is then

$$D_{\max} = z_2 - z_1 = (1.20 - 0.784) H_R = 0.416 H_R \quad (16)$$

$$\text{For } \rho = 0.5, D_{\max} = 0.46 H_R$$

From this it is apparent that satisfactory illumination cannot be attained with the antenna under test mounted where the lower edge of its aperture barely clears the ground. The antenna center must be mounted at 2.4 times its vertical dimension to provide  $\pm 1/4$  db illumination across its vertical aperture.

The analysis above has been based upon a ray theory approach to radiation from an isotropic source. It is also valid for a horizontal dipole since only variations in the vertical plane have been considered. The following section will show another approach to the analysis.

#### D. THE COEFFICIENT OF REFLECTION

A smooth flat surface produces a specular reflection given by the Fresnel relations for the cases of the electric vector impinging horizontally and vertically respectively on a dielectric surface:

$$\left. \begin{aligned} \frac{E_R}{E_o} \quad H &= - \frac{\sin (i - r)}{\sin (2 + r)} \\ \frac{E_R}{E_o} \quad V &= \frac{\tan (i - r)}{\tan (2 + r)} \end{aligned} \right\} \quad (17)$$

where  $i$  is the angle of incidence, and  $r$  the angle of refraction. Figure 28 shows a plot of (17) squared for fresh water and earth at frequencies above 1 Mc. At grazing angles,  $i$  approaches  $90^\circ$ , and both equations in (17) become:

- 1 Fresh Water, Horizontal Polarization
- 2 Fresh Water, Vertical Polarization
- 3 Soil, Horizontal Polarization
- 4 Soil, Vertical Polarization

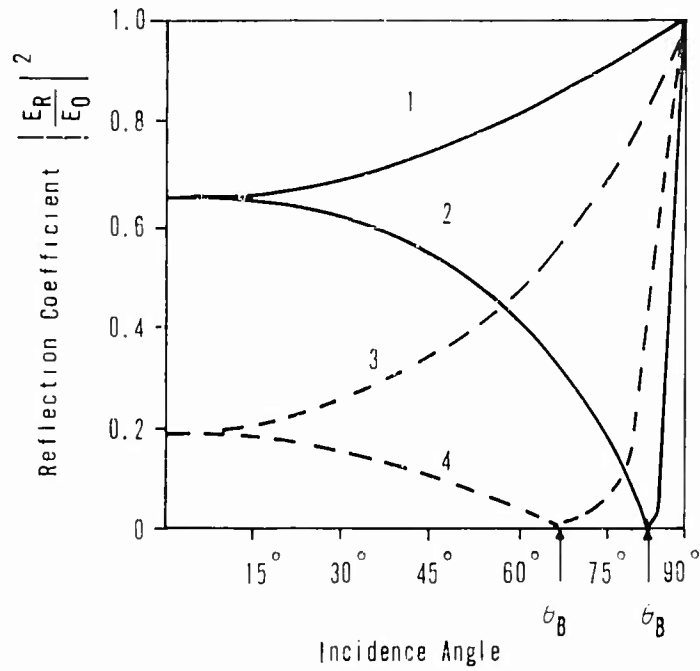

Fig. 28 - Reflection Coefficient

Material	Dielectric Constant	Frequency
Smooth dry ground	2	3.2 Gc
Smooth wet ground	5 to 25	3.2 Gc
Dry grass	3	3.2 GC
Wet grass	6	3.2 GC
Asphalt	3	1.0 Mc
Snow*	3	10.0 Gc
Ice*	25	50.0 Mc
* - depends on thickness		

Table I - Dielectric Constants

$$\left. \begin{aligned} \frac{E_R}{E_o} \quad H &= -1 \\ \frac{E_R}{E_o} \quad V &= -1 \end{aligned} \right\} \quad (18)$$

This shows that both horizontally and vertically polarized waves are reflected with opposite phase to the primary wave.

On the basis of Figure 28 the range surface may be assumed to be a relatively lossless dielectric at grazing angles of incidence. This will not be strictly true at the higher frequencies (i. e., above X-Band) where the dielectric loss tangent becomes significant, but is sufficiently true for use here.

Equation (18) also shows that the reflection coefficient becomes unity for grazing angles. This fact can be shown to apply equally well to surfaces of finite conductivity. It is also seen that the reflection coefficient descends very rapidly for vertical polarization as the grazing angle is increased. The reflection coefficient will go to zero when  $(i + r)$  is  $90^\circ$ . The value of  $i$  for which this occurs is called the Brewster angle. The value of the Brewster angle is

$$\theta_B = \arctan \sqrt{\epsilon_R} \quad (19)$$

where  $\epsilon_R$  is the dielectric constant of the reflecting surface. An important phase change occurs at this point. For values of  $i$  less than the Brewster angle, the reflection is in phase with the direct wave. For values of  $i$  greater than the Brewster angle, the reflection is out of phase. The out-of-phase reflection is required for the proper operation of the range. The appearance of an in-phase wave during testing would cause an amplitude variation in the received signal.

For earth, of dielectric constant of 3, the Brewster angle is  $60^\circ$ . For water, of dielectric constant 81, the Brewster angle becomes  $83.5^\circ$ . At a range of 1000 feet with one antenna at 100<sup>1</sup> this corresponds to height of 14 feet at the other antenna. Thus, at this 1000-foot range, spurious signal amplitude variations are expected during or just after a rain storm or upon melting of snow, when the antenna height exceeds 14 feet. At a range of 650 feet the Brewster angle is always exceeded.

## E. AN ALTERNATE DERIVATION

The vertical energy distribution can be derived using the image principle. The procedure is to replace the ground plane by an image source, compute the array pattern of two point sources of equal magnitude, out of phase by  $180^\circ$  and separated by twice the height between the transmitting antenna and ground. Note that if the reflection coefficient is to be taken into account, the lower source must be reduced in magnitude by this factor as in the previous derivation. This computed array factor must then be multiplied by the element factor; that is, the transmitting antenna pattern. The field strength in the far field, assuming  $\rho = -1$ , as a function of the elevation angle  $\alpha$  (taken from ground level, the center of the array, to the receiving aperture) is then given by:

$$E(\alpha) = E_0 F(\alpha) \sin \frac{2\pi H_T}{\lambda} \sin \alpha \quad (20)$$

where  $F(\alpha)$  is the elevation pattern of the transmitting antenna. Generally the beamwidth of the element factor is large compared with the beamwidth of the array factor, and thus  $F(\alpha)$  may be taken as unity or constant over the elevation angles of interest.

For the conditions of interest here, i. e., small grazing angles and small elevation angles,

$$\sin \alpha \simeq \tan \alpha \simeq \frac{H_R}{R}$$

Substitution in (20) yields

$$E(H_R) \simeq E_0 \sin \frac{2\pi H_T H_R}{\lambda R} \quad (21)$$

where  $E_0$  is a constant as described above.

The solution of this equation gives rise to the multilobed field already described, where the number of lobes depends upon the wavelength and transmitting antenna height above the ground. When the antenna under test is located at the first maximum the transmitted energy incident upon it appears to emanate from the phase center of the transmitter-image combination. This phase center is coincident with the ground at the base of the transmitter. For the condition that the antenna under test be at the first maximum (21) reduces to equation (12) already derived

$$4H_R H_T = \lambda R$$

This image approach shows that the illumination pattern of the transmitting source is essentially independent of the frequency of operation and the transmitting antenna aperture. However, note that this last condition is dependent upon the assumption that the beamwidth of the element factor is large compared to the beamwidth of the array factor.

Since the nature of the antenna test range under consideration involves relatively large distances, and for other reasons to be considered in the next section, the power required may become relatively high, it may be desirable in some cases to use transmitting antennas of relatively high gain. This necessarily implies that the beamwidth of the element factor becomes small, and so the condition stated above could be violated. This would also affect several of the assumptions involved in the derivation of the Fraunhofer null depth measurement criterion. Further analytical studies are required to establish the limits for both the horizontal and vertical patterns of the transmitting antenna.

The discussion of the image method analysis follows that given by Cohen and Maltese.<sup>10</sup>

#### F. RANGE DESIGN CONSTRAINTS

In a problem with a number of variables, many possible solutions can arise as one factor is traded off against another. However, the satisfactory solutions possible are limited by design requirements which set maximum, minimum, or specific values on some parameters and require other parameters to be independent variables. A summary of the design constraints and resulting variables is given below.

##### Design Limits

Frequency:	40 Mc to 40 Gc
Maximum aperture:	60 ft.
Maximum range:	6000 ft. (design recommendation)
Antenna height, $H_R$ :	building plus pedestal

### Equations

Fraunhofer criterion:  $R_{\min} = \frac{2aD^2}{\lambda}$ ,  $D = D_R + D_T$

Reflection Range Equation:  $4 H_T H_R = n\lambda R$

Vertical Dimension Restriction:

$$D_R \text{ max (vertical)} = \frac{0.42}{n} H_R$$

Transmitter Antenna Size Restriction:

$$D_T \leq 0.414D_R$$

### Independent or Predetermined Variables

Frequency.	independent within design limits-- set by test plan.
System Antenna Aperature.	independent below maximum limit-- set by antenna provided.
System Antenna Height:	predetermined by building and antenna vertical dimension.
"a" (null depth accuracy criterion)	independent within available range length-- set by test plan.

### Dependent Variables

Range	minimum set by Fraunhofer criterion and desired null depth accuracy. Trade-off with transmitter height possible and also "n."
Transmitter height:	set by reflection range equation. Trade-off with range and "n" possible.
Height mode "n":	usually $n = 1$ , except for relatively small vertical aperture dimension of receiving antenna where $n = 3, 5, 7$ is possible.

## CHAPTER IV

### SCATTERING AND UNCONTROLLED REFLECTION

#### A. SITE ERRORS

The recorded antenna pattern is subject to errors arising from a number of sources. Deviations from the desired linear or logarithmic characteristic of the attenuators, amplifiers and mixers of the receiving system will obviously introduce error. Such difficulties can be largely minimized by adequate engineering. At minimum signal levels the signal-to-noise ratio will determine the magnitude of the errors. The magnitude of this error can always be reduced by increasing the amount of power radiated.

Another source of error constitutes a more serious limitation upon the range performance: the amplitude and phase uniformity of the radiation presented to the antenna under test. In order to obtain the theoretical far field pattern, both of these characteristics should be planar, which requires that the source antenna be at an infinite distance. When the source antenna is at a finite distance the pattern differs from the theoretical as discussed in Chapter II. Such patterns are valid for whatever distance may have been used to obtain them. In this sense they can be considered error free, provided that the amplitude and phase characteristics of the illumination are known. The factor that does constitute a very real source of error is the perturbations in the illumination arising from unknown or uncontrolled sources. These will originate from scattering and reflections from the range surface and objects on the surface.

The field of the source antenna existing with the antenna in place and radiating at a given frequency may be defined as the total field. The scattered field may be defined as the difference between the total field and the field that would exist if the site were removed. The scattered field pattern is the site error: more exactly, the source of error arising because of the presence of the site itself.

In practice it is usually possible to identify a number of specific reflections from large objects on the site by correlation of their physical position with relation to a particular apparent lobe on the measured pattern. This situation is discussed in greater detail in the next section. Variations in the measured pattern due to such things as the diffuse scattering from the ground surface,

changes in air temperature or water content, or polarization sensitive scattering effects are not easily identified or controlled. In general, as the level of the site error is reduced, their complexity increases so that the scattering pattern becomes increasingly difficult to describe.

It would be difficult to obtain the scattering pattern of a site. The experiment suggested by the definition cannot be performed until the day when antennas and the entire site transmitting-receiving-recording system can be placed in space. As yet, no techniques have been adequately developed that will allow the scattering pattern of a site to be obtained. This is unfortunate for the maximum values, the peaks, of the scattering pattern will determine the accuracy of a measured antenna pattern at its nulls.

The following simple analysis may be used to get an idea of the effects of the relative magnitude of the site error. Let  $Y$  be the detected voltage level at the recorder without any site effects--the true pattern level--and let  $X$  be the detected voltage level of the site effect only--the scattered pattern level. The deviation of the actual measured pattern with respect to the true pattern is then

$$20 \log_{10} \left( 1 \pm \frac{X}{Y} \right).$$

Let the maximum magnitude of this deviation be considered as the limit of the accuracy of the measured pattern. This accuracy,  $A$ , is then:

$$A = 20 \log_{10} \left( \frac{1}{1 - \frac{X}{Y}} \right)$$

Specifying various values for  $A$  the corresponding values of the ratio may be calculated, resulting in the curve of Figure 29.

This says that to obtain a measurement with a specific accuracy, the level of the signal illuminating the system antenna by any other means than the desired path must be less than direct illumination level by at least the value indicated. For example, if the true antenna pattern is to be measured with an accuracy of  $\pm 1$  db, the level of the scattered return as measured at the antenna terminals must be at least 19 db below the desired path signal level.

It is the main beam gain of a high antenna that will primarily determine the

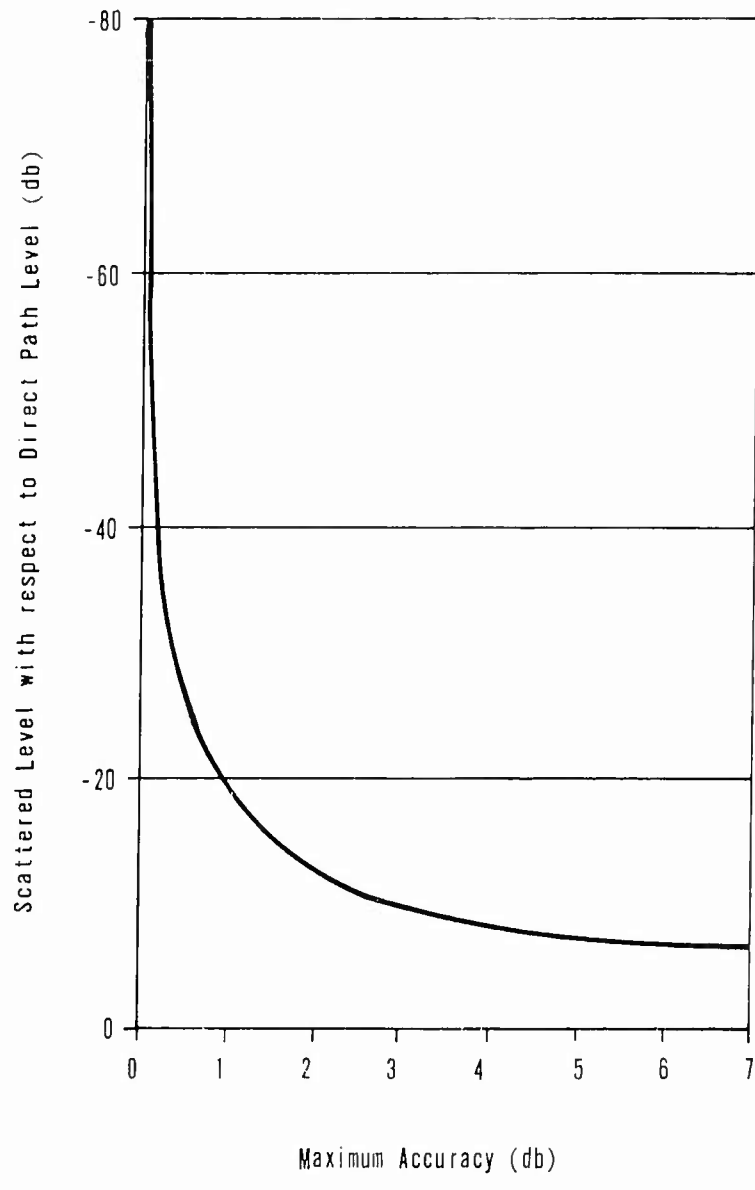

Fig. 29 - Scatter Level Error

maximum allowable level of site scattering. In order to trace a pattern to within  $\pm 1$  db over a 40 db dynamic range, the maximum scattering level would have to be no greater than 59 db below the main beam.

The stipulation of measurement at the antenna terminals means that the pattern of the antenna under test must be taken into account, a most difficult situation, because this says that it is the pattern being measured that affects its own accuracy of measurement.

Rather than attempting to separate the site effects from the measurements, it may be more fruitful to attempt to control them at a specific site, such as Verona, to provide a standard reference site. Other sites may then be calibrated against the standard through the exchange of given antennas.

## B. OBJECT SCATTERING

Since reflection and scattering are anticipated from objects such as buildings and trees on the horizon in the vicinity of the test range, some means must be provided to minimize this source of pattern error. The role of antenna and object scatter directivities will be defined to analyze the amplitude of this error. This result will be useful in the consideration of signal processing techniques.

First, the role of antenna gains must be clarified. See Figure 30. The transmitting antenna will usually be fixed with a gain  $G_{tr}$ , in favor of the receiving, or test, antenna. The transmitting antenna will also have a gain  $G_{ts}$ , toward the scattering object at distance  $R_1$  feet. The power density at the scattering object,  $p_s$ , will be, assuming uniform illumination of the scatterer by the transmitter signal:

$$p_s = \frac{P_t G_{ts}}{4\pi R_1^2} \quad (1)$$

and the total power intercepted,  $P_s$ , by the scatterer is:

$$P_s = \frac{P_t G_{ts} A_s}{4\pi R_1^2} \quad (2)$$

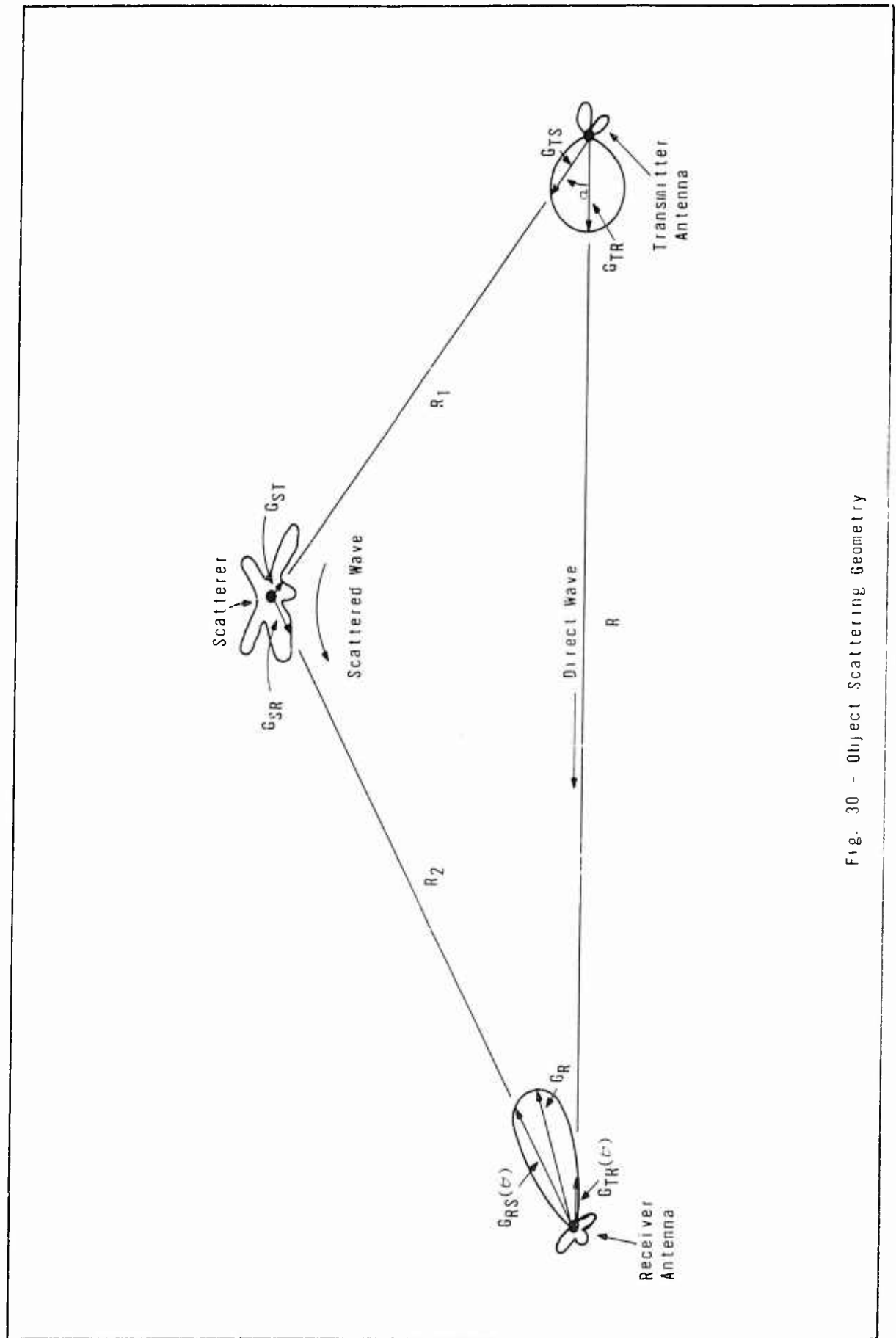

Fig. 30 - Object Scattering Geometry

where

$P_t$  = transmitted power, watts

$G_{ts}$  = power gain of transmitter antenna toward scatterer

$A_s$  = effective scatterer area, square feet

$R_1$  = distance from transmitter antenna to scatterer, feet.

This RF power will be re-radiated by the scatterer in various directions. The gains  $G_{sr}$  and  $G_{st}$  of this scatterer in the direction of the receiver and transmitter respectively must be found experimentally for all but the simplest case of specular reflection. The latter,  $G_{st}$ , may under some circumstances be approximated by

$$G_{st} = \frac{4\pi A_s}{\lambda^2} \quad (3)$$

The scattered signal power,  $P_{rs}$ , received by the receiver antenna is

$$P_{rs} = \frac{P_t G_{ts} G_{st} G_{sr} G_{rs}(\theta) \lambda^4}{(4\pi)^4 (R_1 R_2)^2} \quad (4)$$

where

$P_{rs}$  = received power from the scatterer, watts

$G_{sr}$  = power gain of the scatterer toward the receiver

$G_{rs}(\theta)$  = receiver directivity toward the scatterer (a function of instantaneous receiver antenna angle)

$R_2$  = distance from the scatterer to the receiver antenna, feet

The power received directly from the transmitter antenna is

$$P_{rt} = \frac{P_t G_{tr} G_{rt}(\theta) \lambda^2}{(4\pi R)^2} \quad (5)$$

where

$P_{rt}$  = power received directly from the transmitter, watts.

$G_{tr}$  = power gain of transmitter antenna toward the receiver

$G_{rt}(\theta)$  = power gain of the receiver antenna toward the transmitter at rotation angle  $\theta$ . (The primary quantity to be measured by this system)

$R$  = distance from the receiver antenna to the transmitter antenna, feet.

The ratio of the scattered wave to the directly received wave is the ratio of (4) to (5),

$$\frac{P_{rs}}{P_{rt}} = \left( \frac{G_{ts} G_{st} G_{sr}}{G_{tr}} \right) \left( \frac{G_{rs}(\theta)}{G_{rt}(\theta)} \right) \left( \frac{\lambda R}{4\pi R_1 R_2} \right)^2 \quad (6)$$

The quantities  $G_{ts}$ ,  $G_{sr}$ ,  $R_1$ ,  $R_2$  and  $R$  will be fixed during a given test. The quantities  $G_{rs}(\theta)$  and  $G_{rt}(\theta)$  will vary widely as the test antenna is rotated through  $360^\circ$ . Their ratio can be both considerably greater and smaller than unity, and hence pose a problem in signal processing, especially during the testing of highly directive antennas, when the desired signal can actually be smaller than the reflected signal. This poses problems of receiver dynamic range gating requirements for a pulsed system, and filter design for the FM system. These problems are surmountable, and a closer look than presented here will be necessary to specify their various solutions.

Two examples will now be given; one for a test of an omnidirectional antenna and the other a highly directional antenna.

Assume the following set of parameters for a 1 Gc system antenna test:

$$R = 6000 \text{ feet}$$

$$R_1 = 3300 \text{ feet}$$

$$R_2 = 3100 \text{ feet}$$

$$G_{ts} = G_{sr} = G_{tr} = G_{rs}(\theta) = G_{rt}(\theta) = 1$$

$$G_{st} = \frac{4\pi A_s \sin \alpha}{\lambda^2}$$

$$A_s = 2500 \text{ square feet}$$

$$\alpha = \text{angle between } R_1 \text{ and } R \approx 18.5^\circ$$

$$\lambda = 1 \text{ foot}$$

then, from (6),

$$\frac{P_{rs}}{P_{rt}} = 2.17 \times 10^{-5} = -46.6 \text{ db.}$$

Thus, for omnidirectional antennas and scatterers, the scattered signal is 46.6 db below the direct signal. In this case, a measurement accuracy better than 1% may be made.

Next, it is assumed that a directive antenna is pointed at the scatterer, has a unity gain toward the transmitter, and that the transmitter has a gain in favor of the receiver of 3 db.

$$G_{rs}(\theta) = 10,000 \text{ (40 db)}$$

$$G_{sr} = G_{tr} = G_{rt}(\theta) = 1 \text{ (0 db)}$$

$$G_{st} = \frac{4\pi A_s \sin \alpha}{\lambda^2} \text{ (40 db)}$$

$$G_{ts} = 5 \text{ (7 db)}$$

$$G_{tr} = 10 \text{ (10 db).}$$

Then from (6).

$$\frac{P_{rs}}{P_{rt}} = 0.108 = -9.6 \text{ db.}$$

In this case the reflected signal is only 9.6 db below the direct signal. If this wave is not eliminated by signal processing, then an error of approximately 3 db may occur. (The signals may add coherently.) Whether any stronger reflections can occur remains to be learned from a survey of existing structures and antenna test conditions under consideration.

As a final example suppose one required that the range must be able to measure nulls which are 60 db down from the main beam. In this case

$$G_{rt}(\theta) = 0.01, \text{ and } \frac{P_{rs}}{P_{rt}} = 10.8 = +10.4 \text{ db.}$$

The signal processing system must be able to eliminate an undesired signal which is 10.4 db above the desired signal. The next chapter on time domain and frequency domain signal processing will discuss means for accomplishing this.

### C. TERRAIN SCATTERING

The effect of the presence of the earth's surface along with its many scattering objects can be interpreted in the following way. The range and environs are divided into three zones as shown in Figure 31. The inner region, Zone I, includes the range surfacing to its edge. Any signal arriving at the receiver after having been reflected or scattered within this region will be unavoidably combined with the direct wave. The reflection tuning method, ramped range, and blocking fences deal with such waves in a known and controllable manner.

Zone II is a buffer zone where the terrain is maintained clear of large scattering objects, since practical signal processing methods cannot remove the subsequent error. An unavoidable residual scatter level will persist which will contribute to the illumination distortion at the receiver aperture. This contribution must be kept as low as possible.

Zone III is all the area outside the buffer zone. The boundary between II and III is a curve of equal time delay, an ellipse, for a scattered wave to arrive at the receiver. No restrictions are placed on what may or may not be present since returns from this area are to be removed by signal processing. The boundary between Zone II and Zone III is admittedly fuzzy, for its sharpness depends on the resolution capabilities of the signal processing equipment; e.g., the gate rise time in a pulsed system and filter cutoff slope in an FM system.

In specifying the qualities of each of these regions, the following restrictive statements may be made:

1. Only specular reflection should occur in Zone I. Slope control of areas is necessary when the reflection timing method is used. A ramp and fences will aid in reducing the slope control requirements at the shortest wavelengths.
2. No diffuse scattering should occur in Zone I.
3. The surface of the boundary Zone I should diffuse and taper smoothly into the characteristics of Zone II. This includes the after-effects of snow removal.
4. Zone II should be clear of buildings, trees, and large bushes, especially close in to Zone I where the grass and weeds should be mowed periodically.
5. Slope control in Zone I should only involve the avoidance of specular reflection from trench edges, creek banks, culverts, fence rows, etc.
6. The boundary between Zone II and Zone III shall be clear of large buildings and transmission lines.
7. Zone III may have any sort of structure, but the presence of radar dishes may create special problems at certain frequencies and the emission sources may require a common site trigger between all buildings.

Zone I requires the greatest effort in terms of construction and perhaps maintenance. Zone II involves relatively little construction, but requires periodic trimming. It does represent, however, the largest area which must be under direct control of the range officer. The larger the size of this area the simpler the signal processing necessary to block the reflections in Zone III.

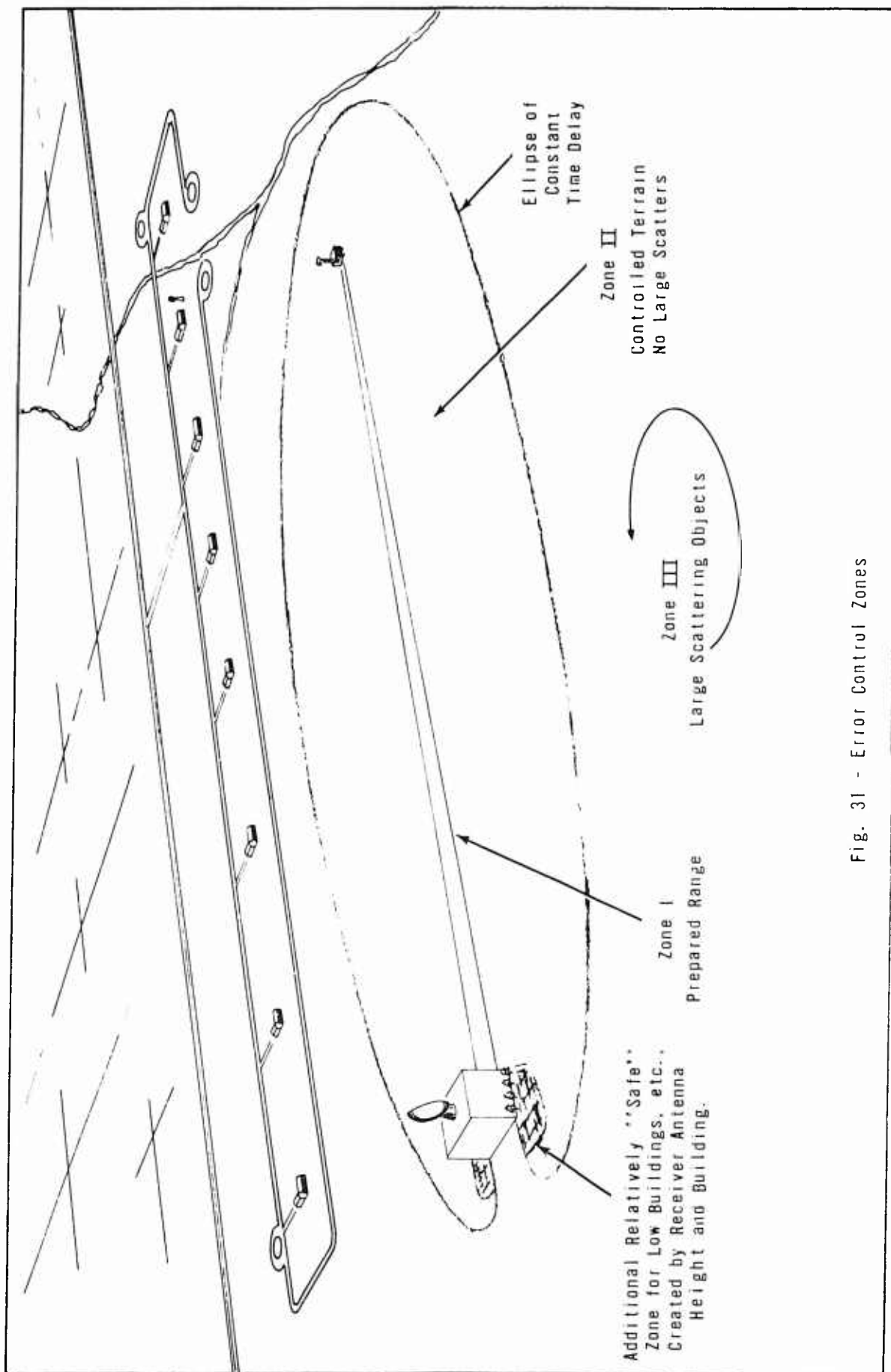

Fig. 31 - Error Control Zones

The section on object scattering assumes values which are just achievable at the Verona test site. A larger area, such as the western dry salt lake beds would simplify signal processing problems. It is also apparent that snow will create a significant problem. A southern or southwestern location would increase the year-round utilization.

CHAPTER V  
SIGNAL PROCESSING TECHNIQUES

A. TIME DOMAIN SIGNAL PROCESSING

It is possible to separate a reflected or scattered signal from the directly transmitted signal on the basis that the time of flight is not the same for the two signals. See Figure 32. In particular, if

$$R = 6000 \text{ feet}$$

$$R_1 = R_2 = 3200 \text{ feet}$$

$$T_1 = 6.10 \text{ microseconds}$$

$$T_2 = 6.50 \text{ microseconds}$$

then

$$T_2 - T_1 = T = 0.4 \text{ microseconds,} \quad (7)$$

and the reflected signal can be eliminated by a suitable gating circuit.

The salient requirements of the gating system are:

1. The transmitted pulse must have a rise-time considerably less than 0.4 microseconds.
2. It must be synchronized with the transmitter so that 0.4 microseconds is clearly resolved.
3. It must have a rejection ratio such that the undesirable signal is sufficiently attenuated so that the data is within the required accuracy.
4. The receiver system must be immune to overload saturation effects, i. e., the recovery time must be less than the PRR period.

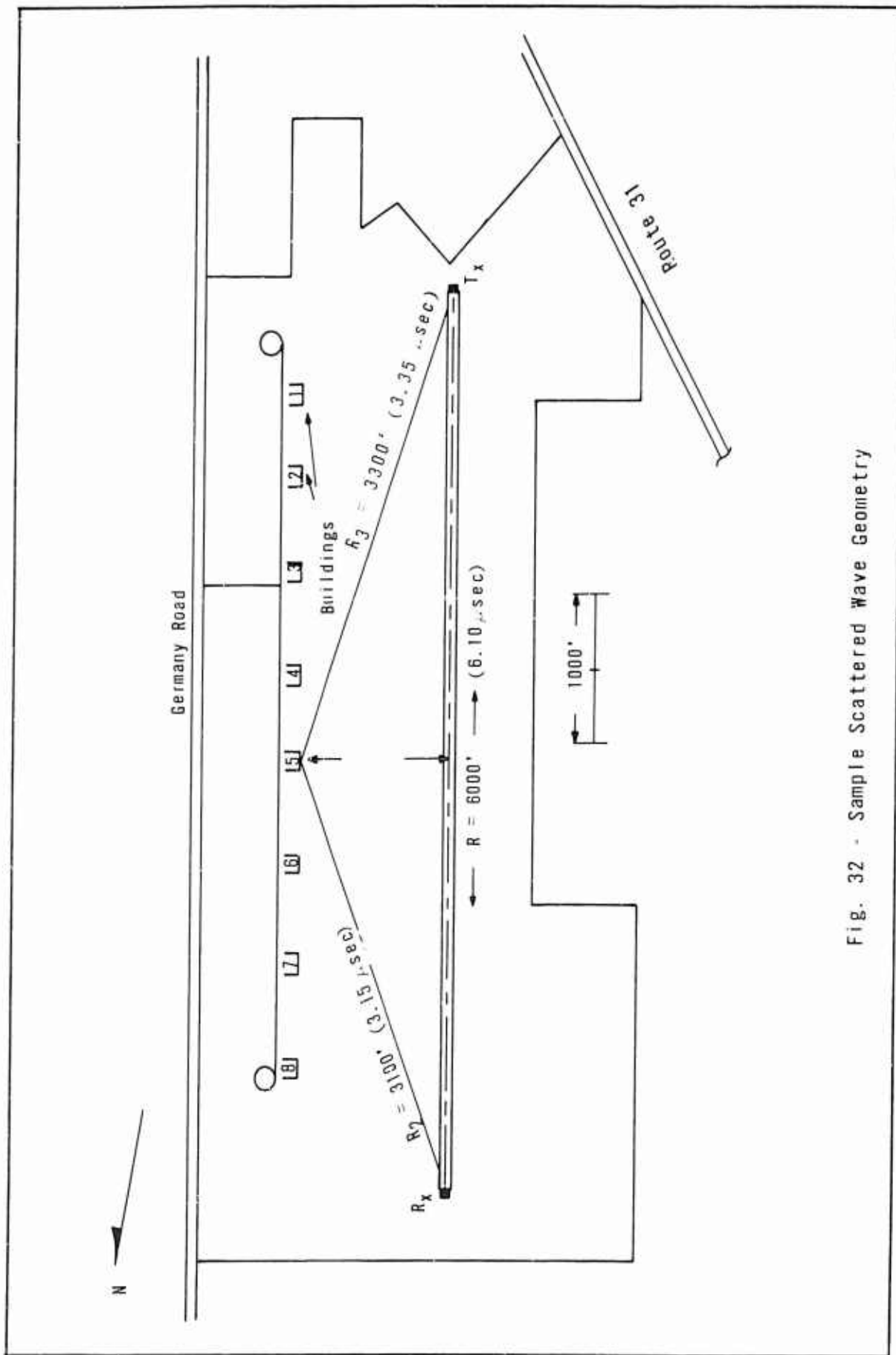

Fig. 32 - Sample Scattered Wave Geometry

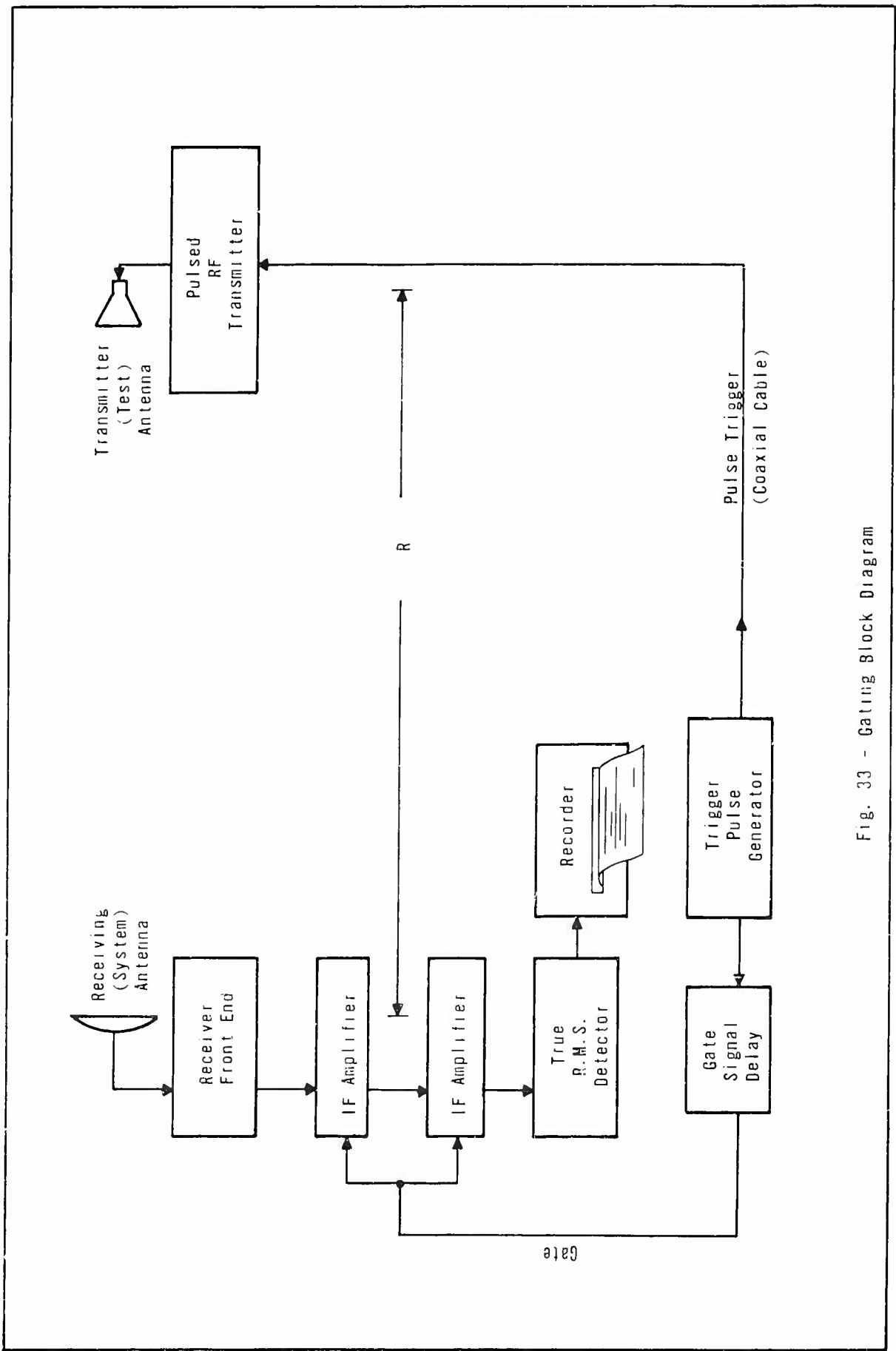

Fig. 33 - Gating Block Diagram

It is recommended that the following answers to these requirements be examined for their feasibility. See Figures 33 and 34.

1. Transmitted pulse length of 0.4 microseconds with 0.1 microsecond or less rise time.
2. Transmitter triggering to be carried out from the receiver location over a coaxial cable with proper delay for receiver gating.
3. Tandem IF stage gating to achieve as wide a dynamic range as possible.
4. Receiver recovery time considerably smaller than the PRR, e.g., less than 1 millisecond for a PRR of 1000 cps.

Items 1 and 4 are self-explanatory. Item No. 2 is suggested for most accurate results, because when the transmitted pulse itself is used, then noise bursts, etc., will cause false triggering, and if the sync pulse is transmitted over a cable to the receiver, it will arrive too late for use at the receiver due to the cable velocity factor. This may be used to gate the following pulse, but better accuracy in timing is achieved in the former system.

Item 3 is suggested so that extremely large gating ratios  $\left(\frac{\text{"open" transmission}}{\text{"closed" transmission}}\right)$  can be achieved. This is necessary when the average datum pulse energy is the measured quantity. A true rms detector such as a thermistor bolometer is recommended. If a peak reading detector is used, the undesired pulse need only be lower than the datum pulse, but this system may be less accurate in the presence of noise.

#### B. FREQUENCY DOMAIN SIGNAL PROCESSING

If the radio-frequency of the transmitted wave is varied linearly over a range of  $\Delta f$  cps in time  $(T-\tau)$ , then there will be a frequency difference,  $f_c$  between the transmitted wave and the directly received wave. Let the rate of frequency swing,  $K$ , be

$$K = \frac{\Delta f}{T-\tau} \text{ cycles/sec}^2. \quad (8)$$

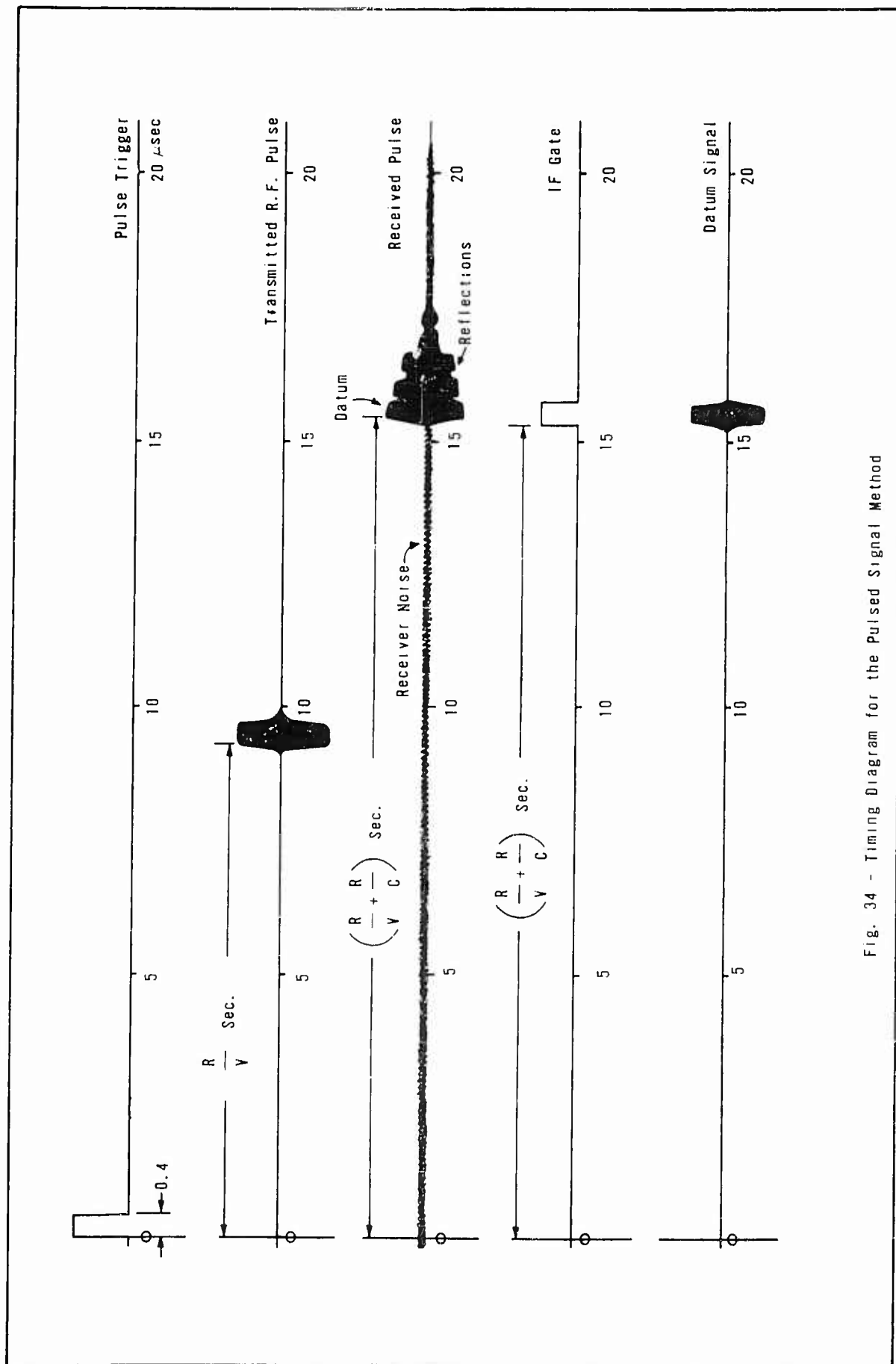

Fig. 34 - Timing Diagram for the Pulsed Signal Method

The frequency difference  $f_o$  comprises a "beat note" at the receiver output where

$$f_o = \frac{KR}{C} \text{ cps} \quad (9)$$

and

$R$  = distance from receiver to transmitter

$C$  = velocity of light =  $3.8 \times 10^8$  meters/second =  
 $9.84 \times 10^8$  feet/second.

This beat frequency will be produced by the receiver when the original RF signal is mixed with the received signal. The amplitude of this beat signal is the datum desired.

For a scattered or reflected path of length  $R_s$ , which is longer than  $R$ , the frequency difference,  $f_s$ , is

$$f_s = \frac{KR_s}{C}$$

The two waves may then be separated at the receiver by a filter which can effectively separate  $f_o$  from  $f_s$ . For instance if

$$K = 200 \text{ Mc}$$

$$R = 6000 \text{ feet}$$

$$R_s = R_1 + R_2 = 6400 \text{ feet,}$$

then

$$f_o = 1220 \text{ cps}$$

$$f_s = 1301 \text{ cps}$$

In the practical test range situation it will be impossible to beat the transmitted frequency itself with the received wave because of the physical separation of the antennas. One must: (a) Send the transmitted signal down a parallel

cable or waveguide to the receiver or (b) Generate the signal for transmission in the receiver building and transmit it over a cable or waveguide for radiation from the transmitter antenna.

In the first case, the comparison signal frequency will be below that of the incoming datum signal frequency due to the inherently slower propagation velocity,  $V$ , of the cable or waveguide. For example, if

$$\begin{aligned} V &= 0.67C \\ R &= 6000 \text{ ft.} \\ R_s &= 64000 \text{ ft} \\ K &= 200 \text{ Mc} \end{aligned}$$

then

$$\left. \begin{aligned} f_o &= K \left( \frac{R}{C} - \frac{R}{V} \right) = -610 \text{ cps} \\ f_s &= K \left( \frac{R_s}{C} - \frac{R}{V} \right) = -529 \text{ cps} \end{aligned} \right\} \quad (10)$$

This system has the disadvantage that waves scattered from progressively greater distances will produce beat notes through zero beat, then positive frequencies which can coincide with the datum frequency. Thus, if  $R_s = 12,000$  feet, then  $f_s = +610 \text{ cps.} = -f_o$

In the second case, the comparison signal will always be above the incoming datum signal. For example, if the previous parameters are used unchanged except for the fact that the radiated wave originates in the receiver building, then

$$\left. \begin{aligned} f_o &= K \left( \frac{R}{C} + \frac{R}{V} \right) = 3050 \text{ cps.} \\ f_s &= K \left( \frac{R_s}{C} + \frac{R}{V} \right) = 3131 \text{ cps.} \end{aligned} \right\} \quad (11)$$

In this case, waves scattered from progressively greater distances will produce beat notes of progressively higher frequencies.

Further analysis is required to choose between the two methods. For instance, the former system produces lower beat notes which are relatively further apart in frequency and hence may be easier to separate by the processing filter. On the other hand, the latter system will facilitate better control of the transmitted frequency modulation waveform, avoid ambiguities of scattered waves, and produce beat notes in a higher part of the audio spectrum where high-Q filters are more feasible.

### C. SIGNAL ANALYSIS

The frequency sweeping cannot be kept on indefinitely, so that a sawtooth sweep waveform suggests itself. It will be shown that there exists a peak-to-peak frequency deviation which will just separate the scattered wave from the undesired wave, (Naturally, a wider frequency deviation will more than adequately separate the two waves.)

The details of the datum signal are now derived. The beat signal at  $f_0$  is not continuous, but is interrupted each time the carrier returns to its initial frequency. See Figure 35. For a short time thereafter, the beat signal will be a very high frequency. The scattered wave will produce a similar waveform. These two signals will appear simultaneously at the receiver output as shown in Figure 35d. The datum is the amplitude of the direct wave lower frequency and must be separated by a suitable signal processing filter.

The very high frequency components will be assumed to be sufficiently removed from the datum frequency that they can be easily blocked by the processing filter. There then remains the task of passing a pulsed sinusoidal datum signal while blocking a similar signal of nearly equal frequency. A Fourier analysis of the desired signal is required to find the necessary bandpass characteristic.

The datum signal will be represented as a periodic train of sine waves of frequency  $f_0$ . See Figure 6b. The pulsed repetition rate is  $\frac{1}{T}$ . The rest period is  $\tau$ , which is the sum of propagation, flyback, and settling times of the swept frequency signal. The latter can arise due to nonlinearity in the FM sweep generator waveform. See Figure 36a. In other words, the function  $F(t)$  shown in Figure 36b, is defined as

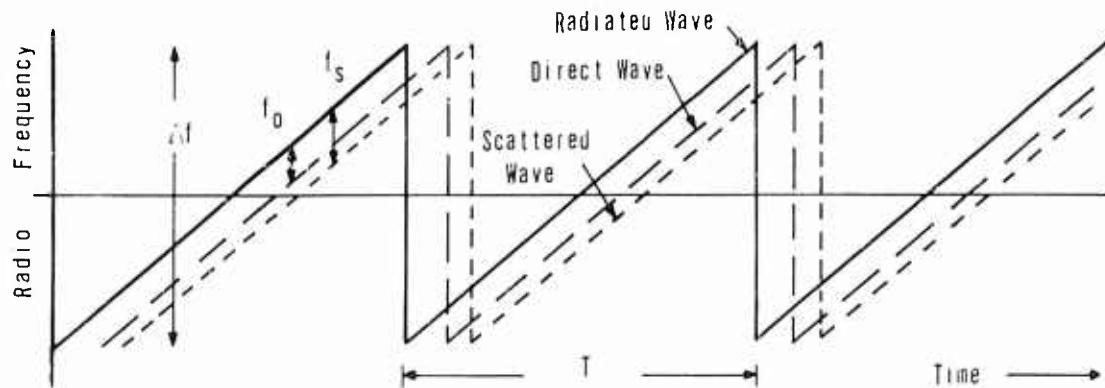

35a. Radio Frequency-Sweep Waveform

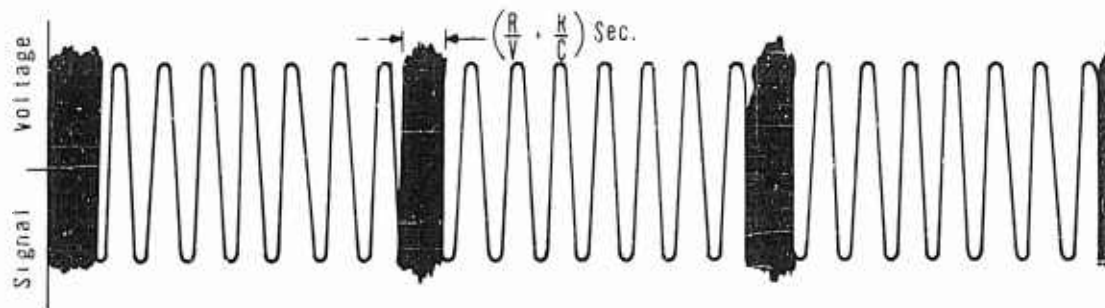

35b. Direct Wave Beat Signal

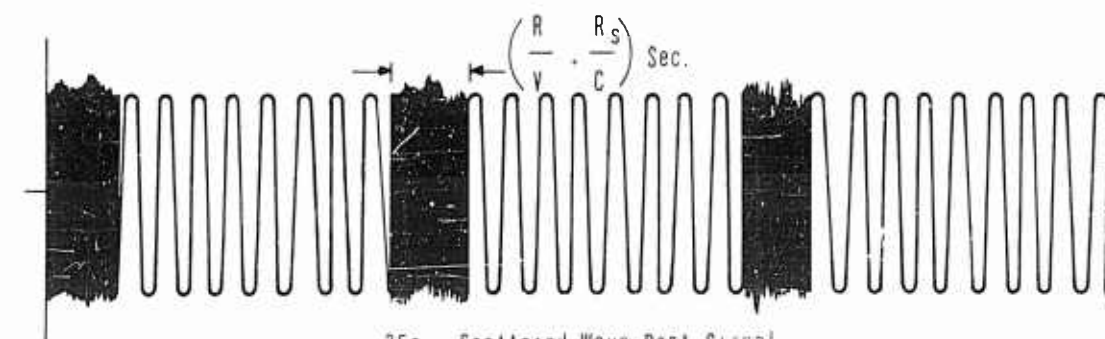

35c. Scattered Wave Beat Signal

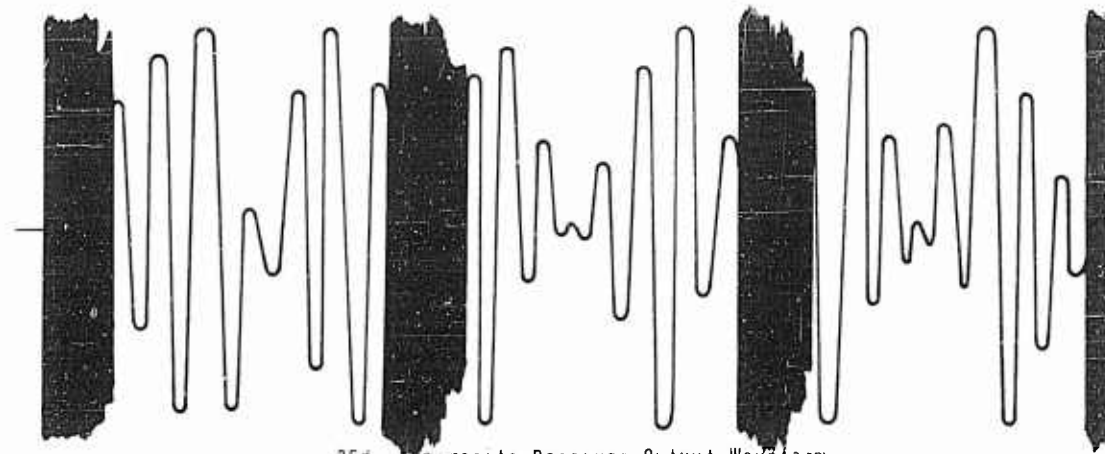

35d. Composite Receiver Output Waveform

Fig. 35 FM Sweep Waveform and Receiver Signals

$$\left. \begin{aligned} F(t) &= \sin 2\pi f_0 t, & 0 < t < (T - \tau) \\ F(t) &= 0, & (T - \tau) < t < T. \end{aligned} \right\} \quad (12)$$

The fourier series representation, which is also the spectrum, for this function is

$$F(t) = \frac{(T - \tau)}{T} \sum_{k=1}^{\infty} \left[ \frac{\sin \left( 2\pi f_0 - \frac{k\pi}{T} \right) (T - \tau)}{\left( 2\pi f_0 - \frac{k\pi}{T} \right) (T - \tau)} - \frac{\sin \left( 2\pi f_0 + \frac{k\pi}{T} \right) (T - \tau)}{\left( 2\pi f_0 + \frac{k\pi}{T} \right) (T - \tau)} \right] \sin \frac{k\pi t}{T}. \quad (13)$$

This spectrum peaks, by virtue of the denominator of the first term in the brackets vanishing, for values of the integer  $k$ , in the neighborhood of

$$k \simeq 2f_0 T \quad (14)$$

In this region, the amplitude of the individual spectral components are approximated as

$$F(u) = \left( \frac{\sin u}{u} \right) \sin \frac{k\pi t}{T}, \quad (15)$$

where

$$u = \left( 2\pi f_0 - \frac{k\pi}{T} \right) (T - \tau).$$

The frequencies of the components in this region are

$$f_k = \frac{k}{2T}, \quad (16)$$

which are seen to be harmonically related to the repetition rate and not necessarily the pulsed frequency,  $f_0$ . The factor  $\frac{\sin u}{u}$  can be interpreted as

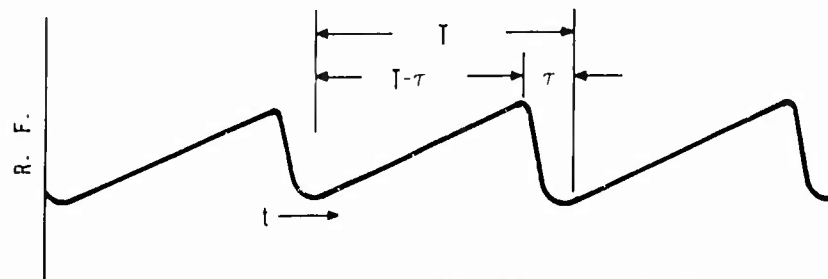

36a. Practical FM Sweep Waveform

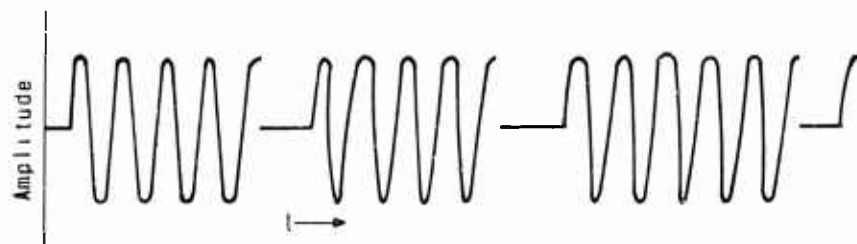

36b. Datum Signal Representation

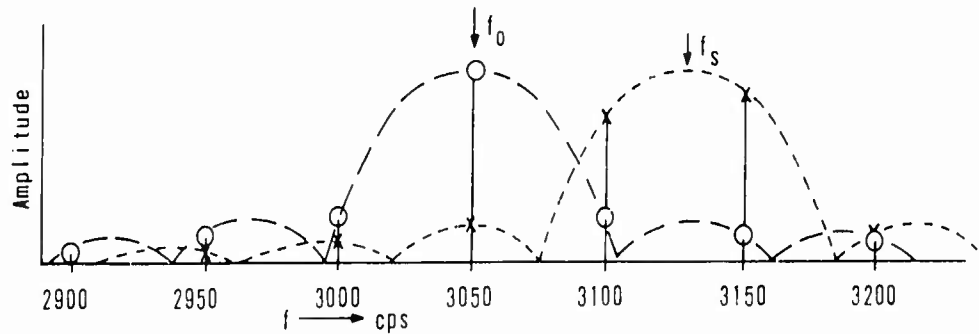

36c. Signal Plus Scatter Spectrum,  $R = 6000'$

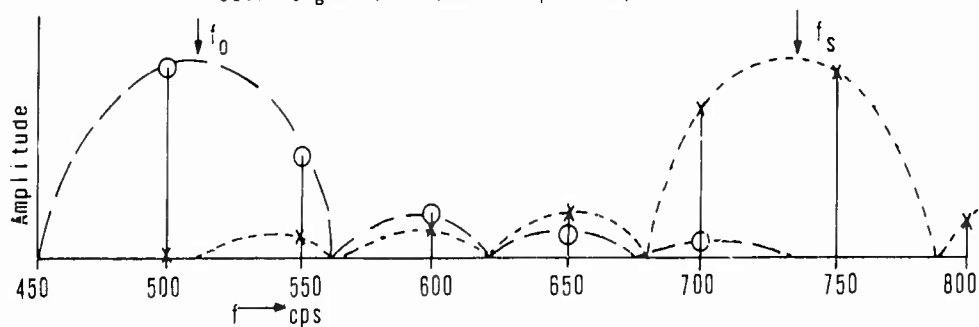

36d. Signal Plus Scatter Spectrum,  $R = 1000'$

Location	$m$	$(\text{Sin } U)/U$	db error
Central Max.	-	1	-
First Sub. Max.	$3/2$	-0.212	-1.7
Second Sub. Max.	$5/2$	+0.127	+1.0
Third Sub. Max.	$7/2$	-0.091	-0.8

36e. Spectra Maxima

Fig. 36 - Datum Signal Characteristics

the envelope amplitude of all possible frequencies which may arise for a given value of  $T$ . This envelope is centered at  $f_o$ , has nulls of frequencies

$$f_n = f_o + \frac{n}{2(T-\tau)}, \quad n = \pm 1, \pm 2, \pm 3, \dots, \quad (17)$$

and subsidiary maxima at

$$f_m = f_o + \frac{m}{2(T-\tau)}, \quad m = \pm 3/2, \pm 5/2, \pm 7/2, \dots \quad (18)$$

Such a spectrum is depicted in Figure 36c for the previously cited parameters of the transmitted signal originating in the receiver building. For the sake of clarity, the scattered wave is assumed equal in amplitude to the direct wave. In addition,  $\tau$  is chosen as 19% of  $T$ . The parameters of the spectrum of the direct wave become

$$f_o = 3050 \text{ cps}$$

$$T = 10^{-2} \text{ sec}$$

$$\tau = 10^{-3} \text{ sec}$$

$$k \approx 61$$

$$f_k = 50 \text{ k}$$

$$f_n = 3050 \pm 55.6 n \text{ cps } n = 1, 2, 3, \dots$$

$$f_m = 3050 \pm 55.6 m \text{ cps } m = 3/2, 5/2, 7/2, \dots$$

For the scattered wave, one has

$$f_s = 3131 \text{ cps}$$

$$k_s \approx 62.6$$

$$f_k = 50 \text{ k}$$

$$f_{ns} = 3131 \pm 55.6 n \text{ cps } n = 1, 2, 3, \dots$$

$$f_{ms} = 3131 \pm 55.6 m \text{ cps } m = 3/2, 5/2, 7/2, \dots$$

From other considerations this FM system may have more practical use at shorter ranges, so consider the problem where

$$R_1 = 1050 \text{ ft.}$$

$$R_2 = 1050 \text{ ft.}$$

$$V = 0.67 C$$

$$K = 200 \text{ Mc}$$

$$T = 10^{-2} \text{ sec}$$

$$\tau = 10^{-3} \text{ sec}$$

From (11), (14), (16), (17) and (18),

$$f_o = 510 \text{ cps}$$

$$f_s = 734 \text{ cps}$$

$$k = 10.2$$

$$f_k = 400, 450, 500, 550, 600 \text{ ---- cps}$$

$$f_n = 510 + 55.6 n \text{ cps } n = \pm 1, \pm 2$$

$$f_m = 510 + 55.6 m \text{ cps } m = \pm 3/2, 5/2, \dots$$

The composite spectra are shown in Figures 36c for the first example and 6d for the second example. The envelope of the direct wave is dashed, and that of the scattered wave is dotted. The amplitude of the individual frequency components are indicated by the height of the vertical spectral lines. The direct wave components are indicated by circles, and the indirect by triangles. Note that the frequencies of the spectral components of the direct and scattered waves coincide, but that their amplitudes differ. Note also, that in the latter case, where the scattered path is increased, the signals are separated more in frequency.

#### D. ERROR AND THE SIGNAL PROCESSING FILTER

Error in signal amplitude measurement arises from three sources.

1. Spectral components of scattered waves can fall onto the datum signal.
2. Spectral components other than the datum frequency contribute to the detected power.
3. Receiver and external noise.

Item 3 can be minimized by adequate transmitter power. Item 1 will be most troublesome, for the error signal will add coherently to the datum signal. Its value is determined by the amplitude of the  $\frac{\sin u}{u}$  function for the scattered wave at the datum frequency,  $f_0$ . In the event that the scattered wave amplitude is equal to that of the direct wave, the greatest possible amplitude of the first subsidiary maximum of the undesired signal is 0.212. See Figures 36c, 36d and 36e. This gives rise to a maximum error of of -1.7 db, (the phase of the waves must also be accounted for). If a second wave which is scattered from a further distance has a second subsidiary maximum falling onto the primary signal, then the error will be +1 db, the third -0.8 db, and so on. This error can be minimized only by a proper choice of  $\Delta f$  in relation to  $(R - R_s)$ .

Thus, if a 1 db error is not tolerable, then the second subsidiary maximum of the scatter signal should not be allowed to fall on the datum. Placing the second null on the  $f_0$  would accomplish this.

Item 2 is best removed by a signal processing filter. These components add incoherently to the datum signal when true RMS detection is used. This filter must pass all necessary datum components and block the scattered wave components. Since most datum energy occurs throughout the central maximum of the  $\frac{\sin u}{u}$  function centered on  $f_0$ , this is the necessary area of bandpass. Since most scattered energy occurs above this when the signal source is at the transmitter building, and below this when the signal originates at the receiver building, then these shall be the areas of greatest attenuation. The summation of the power of the scattered spectral components which are not blocked by the processing filter constitutes the error in this case. It is the purpose of the data processing filter to minimize this source of error. Its cut-off is probably best placed at the point where  $\frac{\sin u}{u}$  for  $f_0$  has its first null.

Figure 36c shows two scatter components of amplitude nearly equal to that of the desired wave. Attenuation of these by a factor of 10, or 20 db, will reduce the error to about 2%. Accordingly, a minimum of 20 db rejection commencing at the first null of the desired signal envelope is necessary. This attenuation is to be maintained out to the farthest scatter component frequency of this amplitude expected. Attenuation to the other side of the datum frequency is unnecessary, save for noise and general convenience. The filter would have, typically, a rejection notch from 3100 cps to 3200 cps. The notch edge should achieve at least 20 db in going from 3090 to 3110 cps.

#### E. SIGNAL REQUIREMENTS

Various steps must be taken to minimize the error arising from the proximity of the frequency of the scattered signal to that of the direct, or datum, signal. For example, aside from minimizing the cross-section of the scatterer and maximizing the distance between the test range and the scatterer, one may:

1. Make  $T$  a large integral multiple,  $q$ , of  $\frac{1}{f_0}$  so that the spectral component of greatest amplitude occurs at  $f_0$ , i. e.,

$$q = \left( \frac{R}{C} + \frac{R}{V} \right) \left( \frac{\Delta f}{1 - \frac{\tau}{T}} \right) = \text{integer} \quad (19)$$

2. Keep  $\tau$  very much smaller than  $T$ , so that the subsidiary components are nearly zero. This concentrates the signal energy into the  $f_0$  component.

These conditions may be achieved in the following manner. See Figure 37. A pilot FM signal, generated at, say 31 Mc, is sent to a separate antenna adjacent to the transmitter antenna. This wave is radiated and picked up by a fixed pilot receiver antenna on the receiver building. The beat frequency  $f_0$  is compared with a local audio oscillator which is preset to the passband of the signal processing filter. A phase comparator will produce an error signal which may be used to Automatic-Frequency-Control the FM sweep for the pilot oscillator. This produces a very uniform sweep rate. A divider, set to produce a pulse every  $q$  cycles of  $f_0$  will serve to trigger the FM sweep in such a manner that condition 1 above is satisfied. The resulting pilot signal is then heterodyned

with a test signal generator set 31 Mc away from the desired test frequency. This generator must be very stable so that the resulting test  $f_o$  is not spuriously shifted.

This system is not the only method of generating the required signal. It is offered here as an example.

The frequency deviation,  $\Delta f$ , just required to separate the direct and scattered wave is found to depend only upon the path length difference ( $R_s - R$ ) and the propagation velocity of the waves in air. This may be seen if, for instance, one defines that sufficient separation occurs when the second null ( $n = -2$ ) of the scattered wave spectrum envelope falls onto  $f_o$ .

That is,

$$f_o = f_{ns} = f_s - \frac{2}{2(T-\tau)} .$$

$$f_s - f_o = \frac{1}{(T-\tau)} = \frac{\Delta f}{T} \left[ \frac{R_s - R}{C} + \frac{R_s - R}{V} \right] \quad (20)$$

If  $\tau$  is much less than  $T$ , then

$$\frac{1}{\Delta f} = \left[ \frac{R_s - R}{C} + \frac{R_s - R}{V} \right] \quad (21)$$

This designates the minimum peak-to-peak frequency deviation necessary to just resolve the direct wave from the scattered wave with no greater than 1.0 db error.

#### F. COMPARISON OF SYSTEMS

The pulsed system can be conveniently used over any distance because it only requires the transmission of a trigger pulse from the receiver timing unit to the transmitter. The rise time of the RF pulse would preferably be about 0.1 microsecond or less to produce a clean, flat-topped pulse at the receiver before the scattered rays arrive when the full range length is used. This implies a receiver bandwidth of about 10 Mc which is probably excessive for many antenna tests. By using a suitable peak reading device the rise time can be extended to 0.3 to 0.4 microseconds allowing the bandwidth to be reduced to about 3 Mc.



For the FM system it was shown that the RF signal itself must be sent over a coaxial cable for comparison with the transmitted wave. One method of insuring the requisite linearity requires the transmission of an additional pilot signal from the transmitter to the receiver with the frequency determining circuits being located at the receiver. A frequency deviation of approximately 3 Mc is required when the path length difference is the same as the pulse case. The bandwidth requirement is essentially the same for the FM and pulse systems when operating at the same range length.

Also, in an analogous manner, it would be desirable to increase the bandwidth of the FM system to 10 Mc, comparable to the 0.1 microsecond rise time in the pulse system, in order to make the filter that removes the scattered returns more effective.

At the lower frequencies of range operation the generation of fast rise time pulses would be difficult. The pulsed method will work well at all but these lower frequencies.

The FM system will work well at the lower frequencies. However, at higher frequencies the cable loss, power generation, and frequency stability problems all become increasingly difficult. The upper frequency limit due to power requirements may be increased by using power amplifiers along the cable. However, the phase lag introduced by the amplifier and the velocity variations of the long cable may cause aberrations in the rate of frequency deviation of the wave emitted by the source antenna. This coupled with the frequency stability requirements of the heterodyne oscillator will sharply define the upper cut-off frequency of the FM method as being somewhere in the UHF to L-band region. Advances in the state of the art may change this evaluation, but a close look at contemporary components is necessary before design commitments are made.

Since the pulsed system requires a bandwidth of about three megacycles when used at the short range of 1000 feet as required at UHF and below, one expects that the pulsed system will find difficulty in the VHF-UHF range.

Since CW power generation, cable losses, and frequency instability seriously affect the FM method, it is unlikely that it will have great value at L-band frequencies and above.

Consequently, the system suggests itself wherein the FM technique is used in the VHF-UHF range, and that a pulsed system be utilized from L-band up

through Q-band. Some overlap should be provided in the UHF region, say an octave between 250 Mc and 500 Mc, or 500 Mc and 1000 Mc.

## CHAPTER VI

### RANGE SURFACE REQUIREMENTS

#### A. THE RAYLEIGH CRITERION FOR FLATNESS

In order that the intervening terrain produce a purely specular reflection, certain limits must be placed on the allowable roughness. The optical criterion of Lord Rayleigh is frequently used in which the maximum differences in path lengths associated with reflections from the mean terrain and from ridges or depressions is not allowed to exceed  $\frac{\lambda}{8}$ . For angles of incidence approaching grazing, this results in the height of such roughnesses being limited to

$$h \leq \frac{\lambda}{16 \alpha}$$

where  $\alpha$  is the angle of incidence. For instance, if

$$f = 40 \text{ Gc}$$

$$H_R = 120 \text{ ft}$$

$$H_T = 20 \text{ ft}$$

$$R = 6000 \text{ ft}$$

$$\text{then } H \leq 0.75 \text{ inch}$$

Variations of surface position of less than  $\pm 0.75$  inches within the first Fresnel zone then will guarantee that a 100% specular reflection will occur at 40 Gc. Variations greater than this amount will cause a reflection which manifests itself in amplitude and phase variations across the test aperture.

#### B. GRADING TOLERANCE

The Rayleigh criterion predicts a maximum peak-to-peak variation allowable in the area of specular reflection. The question now arises as to how much area need be brought under this control. If all the ground-reflected energy were reflected from a small area between the transmitter and receiver, then the range surface need only comprise a small, very flat, dielectric patch at this point. However, it is not possible to avoid reflections adjacent to this patch since conventional grading tolerances are likely to be at least comparable to the grazing

angles that will occur over the range length under consideration. The condition that a reflection occur at an area other than the geometrical reflection point is that the local slope be equal to half the local grazing angle.

The spurious reflections occurring in the immediate vicinity of the point of specular reflection will arrive at the receiver antenna plane essentially in phase with the direct wave. The resulting amplitude may be greater than that anticipated for the sum of the specular reflection and the direct ray. As the point of spurious reflection moves in any direction away from the point of specular reflection, the resulting wave phase becomes increasingly delayed. Thus, concentric areas which are elliptical in shape occur where the reflected spurious wave will be  $90^\circ$ ,  $180^\circ$ ,  $270^\circ$ , etc. out of phase with the direct and specular wave. See Figure 38. These specific areas may be called Fresnel Zones, and can be represented by the intersection of concentric ellipsoids of revolution with the ramp surface. Their axes coincide with the direct ray. See Figure 39.

### C. ANALYSIS OF ELLIPTICAL FRESNEL ZONES

To determine the size of the elliptical zones, the following analysis is made in terms of the desired reflected ray to simplify the expressions. Consider that the central reflected ray is an axis about which spurious reflections may occur. See Figure 40. This ray may be represented as continuing on a straight path to the transmitter image,  $T_x$ . Those spurious rays which travel a path whose length differs from the central reflected ray by  $K$  feet may be thought of as falling on another elliptical surface as indicated in Figure 40. This ellipsoidal surface has its axis along the central reflected ray. The intersection of this surface with the plane of the range surface is now the boundary of the particular Fresnel zone determined by  $K$ . At this point in the analysis, the problem will be made two dimensional for analytical convenience. A Cartesian coordinate system in  $x$  and  $z$  is centered on the primary point of specular reflection with the positive  $x$ -axis in the direction of the wave propagation. The equation for this ellipse is

$$\frac{(x + s)^2}{a^2} + \frac{z^2}{b^2} = 1$$

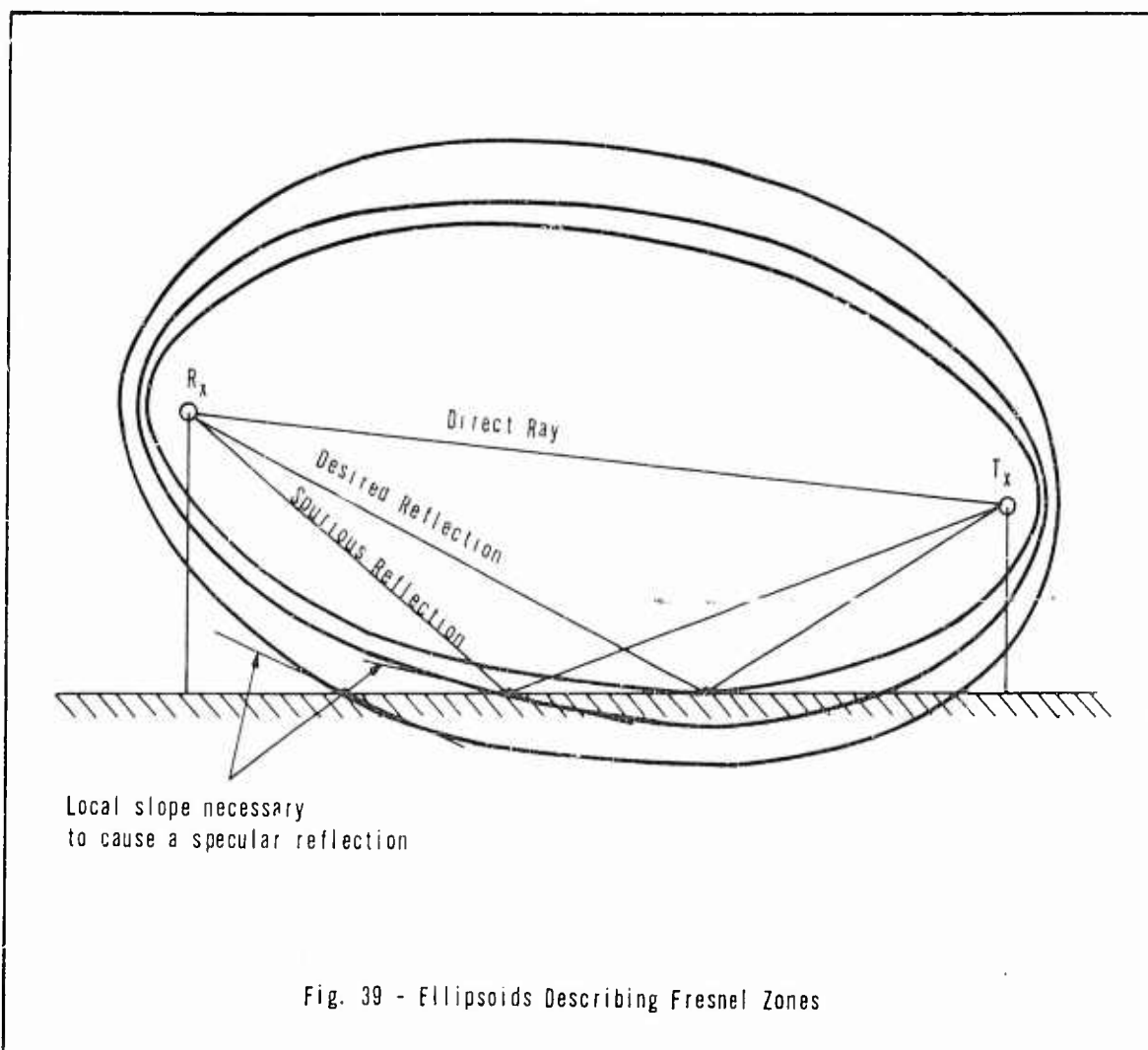
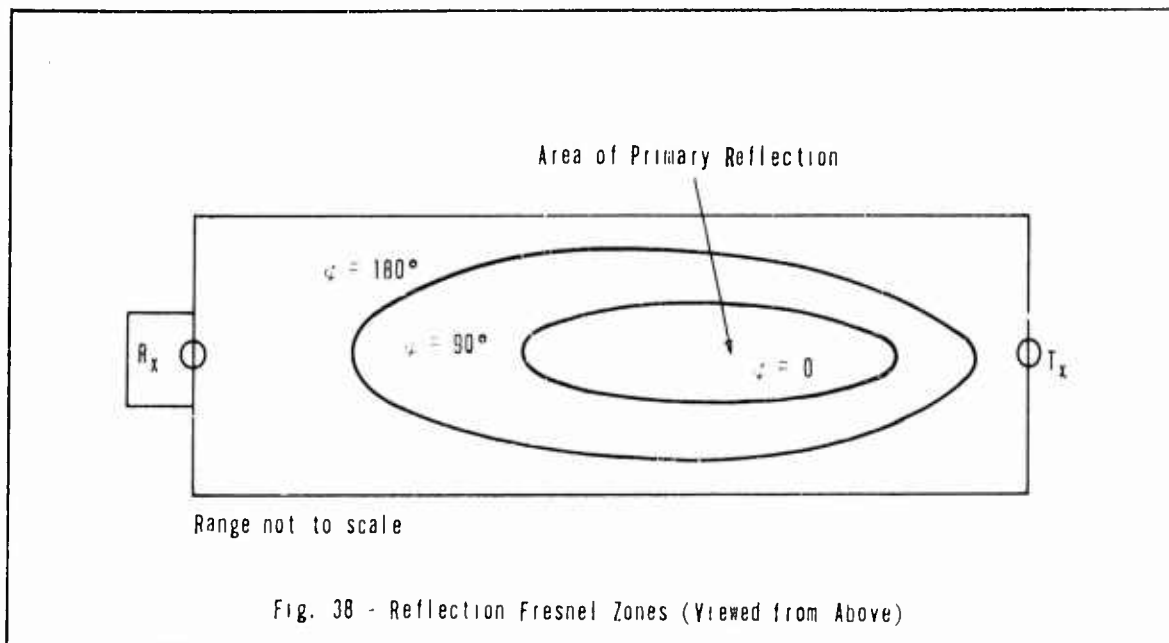

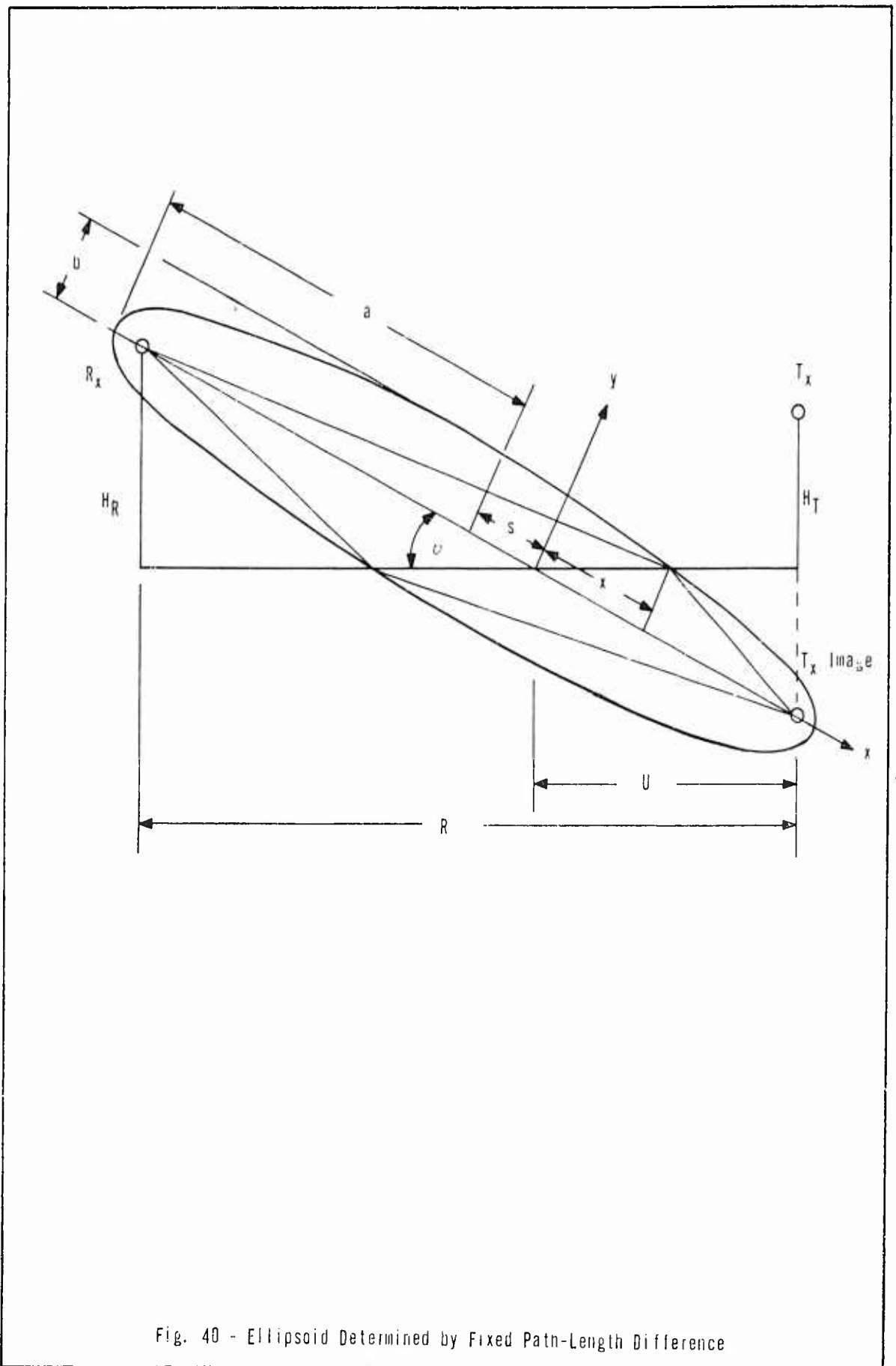

Fig. 40 - Ellipsoid Determined by Fixed Path-Length Difference

where

$$a = \frac{1}{2} \left[ \sqrt{R^2 + (H_T + H_R)^2} + K \right] \quad (1)$$

$$b = \frac{1}{2} \sqrt{2K \sqrt{R^2 + (H_T + H_R)^2} + K^2}$$

$$s = \frac{(H_R - H_T)}{2(H_R + H_T)} \sqrt{R^2 + (H_R + H_T)^2}$$

The equation for the line representing the range surface in this coordinate system is

$$z = mx \quad (2)$$

$$m = \frac{H_R + H_T}{R}$$

The value of  $x$  in this coordinate system is a reasonably good approximation to the desired dimension  $\frac{x}{\cos \theta}$  in Figure 40 since  $\theta$  is small. Upon substituting (2) into (1) one has

$$x^2 \left( \frac{b^2 + m^2 a^2}{b^2} \right) + 2sx + (s^2 - a^2) = 0$$

This gives the two values of  $x$  as

$$x = \frac{-s \pm a \sqrt{1 + \frac{m^2 (a^2 - s^2)}{b^2}}}{1 + \frac{a^2 m^2}{b^2}} \quad (3)$$

These points are the two ends of the particular Fresnel Zones belonging to  $K$ .

When  $K$  is very much smaller than  $R$ , the following approximations may be used:

$$a \cong \frac{1}{2} \sqrt{R^2 + (H_R + H_T)^2}$$

$$b \approx \sqrt{\frac{K}{2}} \sqrt{R^2 + (H_R + H_T)^2} \approx Ka$$

For the longer range lengths,  $H_T + H_R$  is very much less than  $R$ , and the following approximations may be used

$$a \approx \frac{R}{2}$$

$$b \approx \sqrt{\frac{KR}{2}}$$

$$s \approx \frac{R (H_R - H_T)}{2 (H_R + H_T)}$$

Equation (5) may be rewritten as

$$x \approx \left[ \frac{R}{2 + \frac{(H_R + H_T)^2}{KR}} \right] \left[ \frac{H_R - H_T}{H_R + H_T} \pm \sqrt{1 + \frac{2H_R H_T}{KR}} \right] \quad (4)$$

An example is now worked out for the following set of parameters at 720 Mc and full range length:

$$R = 6000 \text{ feet}$$

$$H_T = 100 \text{ feet}$$

$$H_R = 20 \text{ feet}$$

$$\lambda = \frac{4}{3} \text{ feet}$$

$$K = \frac{\lambda}{4} = \frac{1}{3} \text{ foot}$$

The values of  $a, b, c,$  and  $m$  are:

$$a = 3000$$

$$b = \sqrt{10000}$$

$$s = 2000$$

$$m = 2 \times 10^{-2}$$

The resulting values of x are

$$x_2 = -1565 \text{ feet,}$$

$$x_1 = 695 \text{ feet.}$$

The elliptical zone is seen to extend a greater distance toward the center of the range from the point of specular reflection than toward the lower antenna. In other words, as seen from the transmitter antenna, the near value of x, the point of specular reflection, and the far value of x lie respectively at 306, 1000, and 2565 feet from the transmitter.

The maximum width, y, of this Fresnel Zone will occur midway between the two values of x, i. e, where

$$x = \frac{x_1 + x_2}{2}.$$

To find this value of y, the complete equation of the intersection of the ellipsoid of revolution corresponding to K with the range surface is written as

$$\left(\frac{x+s}{a}\right)^2 + \left(\frac{mx}{b}\right)^2 + \left(\frac{y}{b}\right)^2 = 1. \quad (5)$$

This is then solved for y for the value of x given above:

$$y = \pm \sqrt{b^2 \left[ 1 - \frac{x+s}{a} \right]^2 - m^2 x^2}. \quad (6)$$

The value of x at the widest point on the zonal ellipse is

$$x = 435 \text{ feet.}$$

The corresponding value of y is

$$y = \pm 25.6 \text{ feet.}$$

Thus an elliptical area 2259 feet long and 51.2 feet wide comprises the central Fresnel Zone at 750 Mc.

A similar zone can be calculated for X-Band with the following parameters chosen to satisfy the reflection tuning method.

$$\begin{aligned}H_R &= 100 \text{ feet} \\H_T &= 1.5 \text{ feet} \\\lambda &= 0.1 \text{ feet} \\K &= \frac{\lambda}{4} = 0.025 \text{ feet}\end{aligned}$$

The resulting values of the parameters are

$$\begin{aligned}a &= 3000 \text{ feet} \\b &= 75 \text{ feet} \\s &= 2910 \text{ feet} \\x_2 &= -93.2 \text{ feet} \\x_1 &= 10.8 \text{ feet} \\y &= \pm 2.37 \text{ feet}\end{aligned}$$

Thus, the first Fresnel Zone occurs in an ellipse 104 feet long by 4.74 feet wide, and slope control must be exercised at least down to this size.

Carrying the analysis to the extreme of the frequency range, one has at 40 Gc.

$$\begin{aligned}H_R &= 100 \text{ feet} \\H_T &= 0.375 \text{ feet} \\\lambda &= 0.026 \text{ foot} \\K &= 0.00625 \text{ foot}\end{aligned}$$

which results in:

$$\begin{aligned}a &= 3000 \text{ feet} \\b &= \sqrt{16.75} \\s &= 2977.5 \text{ feet}\end{aligned}$$

$$x_2 = -61 \text{ feet}$$

$$x_1 = 16.5 \text{ feet}$$

$$y = \pm 0.536 \text{ feet}$$

In this extreme case, an elliptical area 76.5 feet long and 1.07 feet wide is the first Fresnel Zone, and slope control must be maintained outside this area. This is next to impossible to achieve. The only possible control that may be used is a sharpened ramp apex whose radius is considerably smaller than 0.536 feet. The ramp's sides will have sufficient tilt to deflect the geometric ray clear of the antenna aperture. The ramped surface accordingly reduces the grading tolerance to a value equal to the slope of the ramp.

On a flat plane the peak grading tolerance at any point is given by the angle of the tangent plane to the ellipse around the direct ray passing through that point. The Rayleigh criterion for flatness applies in the first few central Fresnel Zones. The grading tolerance is most stringent when the Fresnel Zones are small, i. e., at the higher frequencies; but decreases as one moves away from the area of specular reflection towards the transmitter or receiver locations.

CHAPTER VII  
THE RAMPED RANGE

A. RAMPED RANGE DIFFRACTION

It appears from geometric ray theory considerations that if the range surface is bent to form a longitudinal ramp with its ridge extending from the transmitter to the receiver, an off-axis ground reflected ray will be deflected away from the receiver aperture. See Figure 41. Furthermore, this configuration will relax the grading tolerance of the ramped surfaces, for it is inconsequential whether the ray reflection deviates slightly from the theoretical angle caused by a perfect surface. Nor does it matter so much if more than one reflection is caused by an undulation in the surface.

However, the wavelength is finite and so the physical effects cannot be predicted by ray theory. With large wavelengths and relatively small ramp angles the ramped surface can appear essentially flat. The angles formed at the sides and peak of the ramp will cause diffraction to occur. The following analysis will evaluate the ratio of the diffracted wave amplitude at the receiver aperture to that of a specular reflection from a flat plane.

By physical principles each edge of the horizontal ramp may be replaced by a half-screen. One then may consider an image of the transmitter to be behind this virtual opaque screen which is tilted at the ramp angle as shown in Figure 42. That area which represents the ramp surface is considered to be an opening in this otherwise opaque screen.

The edge of the screen will give rise to a diffracted wave which propagates into the shadow zone where the receiver is located. The wave is cylindrical in shape, and appears to emanate from the diffracting edge. The situation is analagous to the classical edge diffraction problem treated by many authors.<sup>12-15</sup> The interpretation of Valasek<sup>12</sup> will be used in representing the diffraction through an angle  $\psi$ , into the shadow zone as shown in Figure 42b. The parameters  $U$ ,  $R$ , and  $\psi$ , are indicated in Figure 41.

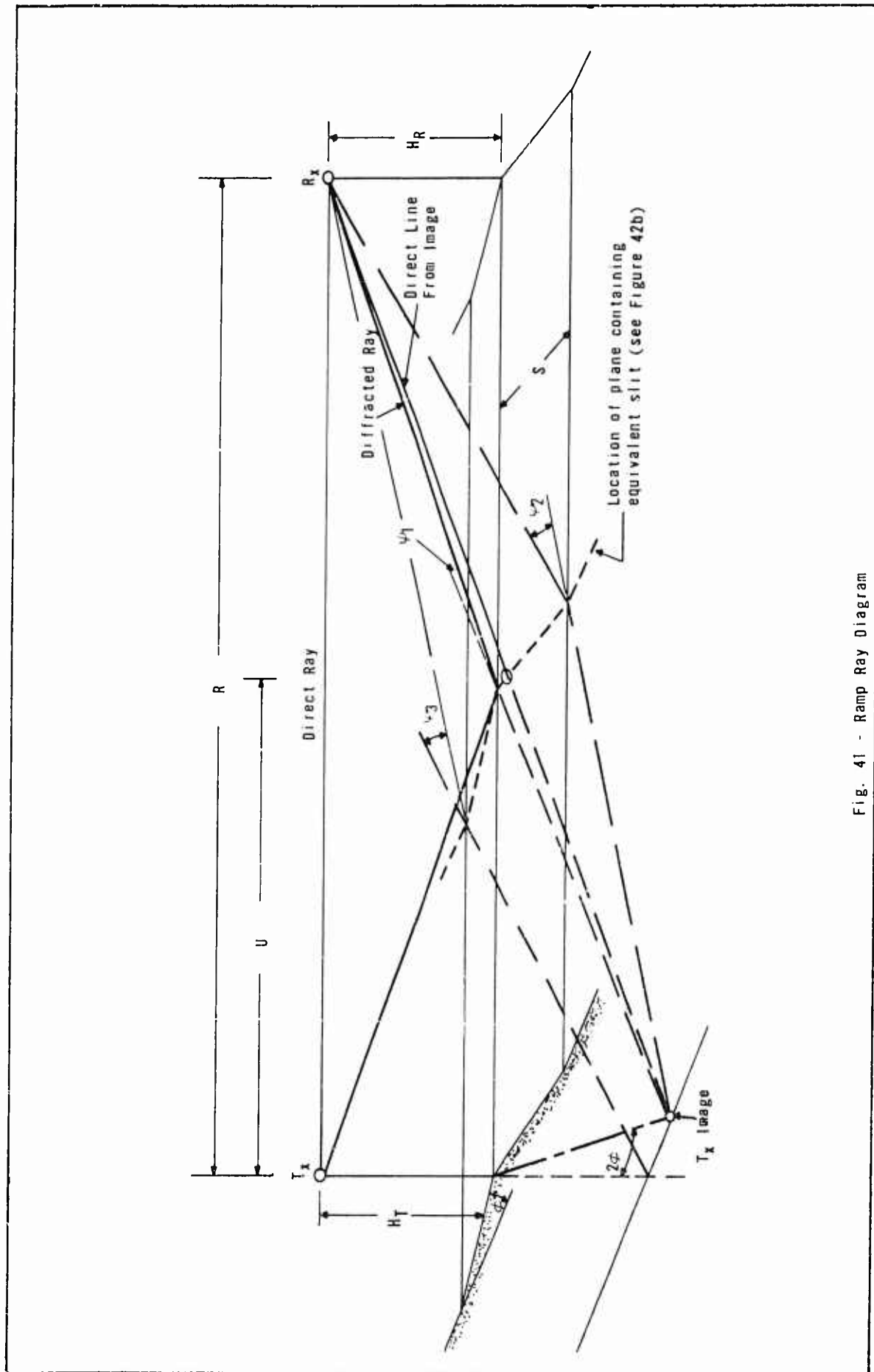

Fig. 41 - Ramp Ray Diagram

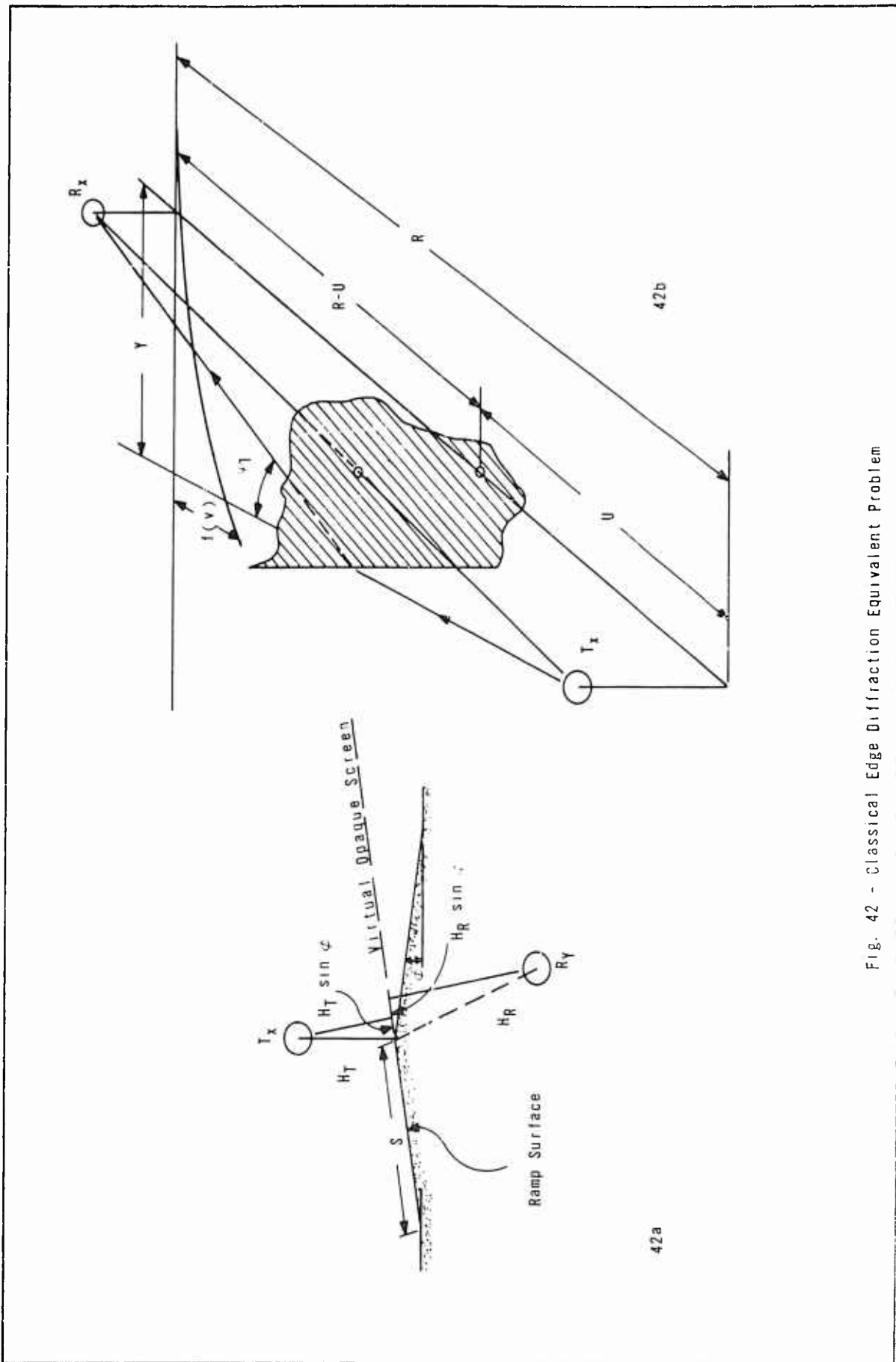

Fig. 42 - Classical Edge Diffraction Equivalent Problem

The angle  $\psi_1$  through which the diffracted ray bends in going from the transmitter image to the receiver is approximated as

$$\psi_1 \approx \frac{H_T \sin \phi}{U} + \frac{H_R \sin \phi}{R - U}$$

where

$$U = \frac{R H_T}{H_R + H_T}$$

so that

$$\psi_1 \approx \frac{z}{R} (H_R + H_T) \sin \phi \quad (1)$$

A second ray will arise from a symmetrical diffraction from the other side of the ramp. The phase of these two diffracted rays is the same so that at  $\phi = 0$ , the combined amplitude will add to unity to equal the basic ground reflection ray.

Two other sets of diffracted rays will arise due to the border between the side of the ramp and the surrounding terrain. In particular, the first right and left hand set arises due to diffraction from the inside edge of the sloped surface at the border. The diffraction angle,  $\psi_2$ , for this ray may be approximated as

$$\psi_2 \approx \psi_1 + \frac{S (H_R + H_T)^2}{R H_R H_T} \quad (2)$$

The last set of rays arises due to the edge presented by the termination of the surrounding terrain at the ramp's edge. Its diffraction angle,  $\psi_3$ , is

$$\psi_3 \approx \frac{S (H_R + H_T)^2}{R H_R H_T} \quad (3)$$

This angle is different from  $\psi_2$  because the receiver image in this case appears symmetrically beneath a screen along the flat earth rather than the ramped surface as was the case for  $\psi_1$  and  $\psi_2$ .

The sum of a right- or left-hand pair of these rays will be zero when  $\phi = 0$ , for they will be of equal amplitude and opposite phase. The phase angles will be less than  $180^\circ$  out of phase as  $\phi$  gets larger. Also, the amplitude of  $\psi_2$  and  $\psi_3$  will grow as the width,  $S$ , of the ramp increases. Further analysis is necessary to completely describe the ramp performance, but an example will show that for practical ramp widths, the diffraction from the peak of the ramp is by far the largest.

Assume the following parameters at 1 Gc

$$\begin{aligned} H_R &= 100 \text{ feet} \\ H_T &= 20 \text{ feet} \\ \lambda &= 1 \text{ foot} \\ R &= 6000 \text{ feet} \\ S &= 50 \text{ feet} \\ \phi &= 10^\circ \end{aligned}$$

then

$$\begin{aligned} \psi_1 &= 7 \text{ milliradians} \\ \psi_2 &= 67 \text{ milliradians} \\ \psi_3 &= 60 \text{ milliradians} \end{aligned}$$

The ratio of the amplitude of the diffracted ray to the direct ray can be represented as

$$\frac{E}{E_0} = f(v) e^{j\beta} \quad (4)$$

where  $f(v)$  is determined from the Cornu spiral of the Fresnel diffraction theory.<sup>12</sup> Figure 43 is a plot of  $f(v)$  vs  $v$  where

$$v_1 \approx \frac{\psi_1}{(H_R + H_T)} \sqrt{\frac{2R H_R H_T}{\lambda}} \quad (5)$$

An approximation for  $F(v)$  empirically derived from Figure 42 is:

$$f(v) = \frac{1}{2 \sqrt{5.4 v^2 + v + 1}} \quad (6)$$

the value of  $\beta$ , the phase angle of the ray, is determined by the path length over which the ray travels. The difference between this path and the direct path will determine the phase of the diffracted ray with respect to the direct, taking the phase change at reflection (diffraction) into account.

From equations (1), (2), (3), and (5), using the parameters of the previous example,

$$v_1 = 0.287$$

$$v_2 = 2.46$$

$$v_3 = 2.53$$

The sum of the left-and right-hand rays will be twice that given by (6), so that, from Figure 43,

$$E_{\text{ridge}} = 0.7 E_D = > -3 \text{ db}$$

$$E_{\text{side}} = 0.18 E_D = > -15 \text{ db}$$

$$E_{\text{out}} = 0.17 E_D = > -15 \text{ db}$$

At 40 Gc, the parameters

$$\lambda = \frac{1}{40} \text{ foot}$$

$$v_1 = 1.8$$

$$v_2 = 15.5$$

$$v_3 = 16$$

result in

$$E_{\text{ridge}} = 0.12 E_D = -19 \text{ db}$$

$$E_{\text{side}} = .014 E_D = -37 \text{ db}$$

$$E_{\text{out}} = .013 E_D = -37 \text{ db}$$

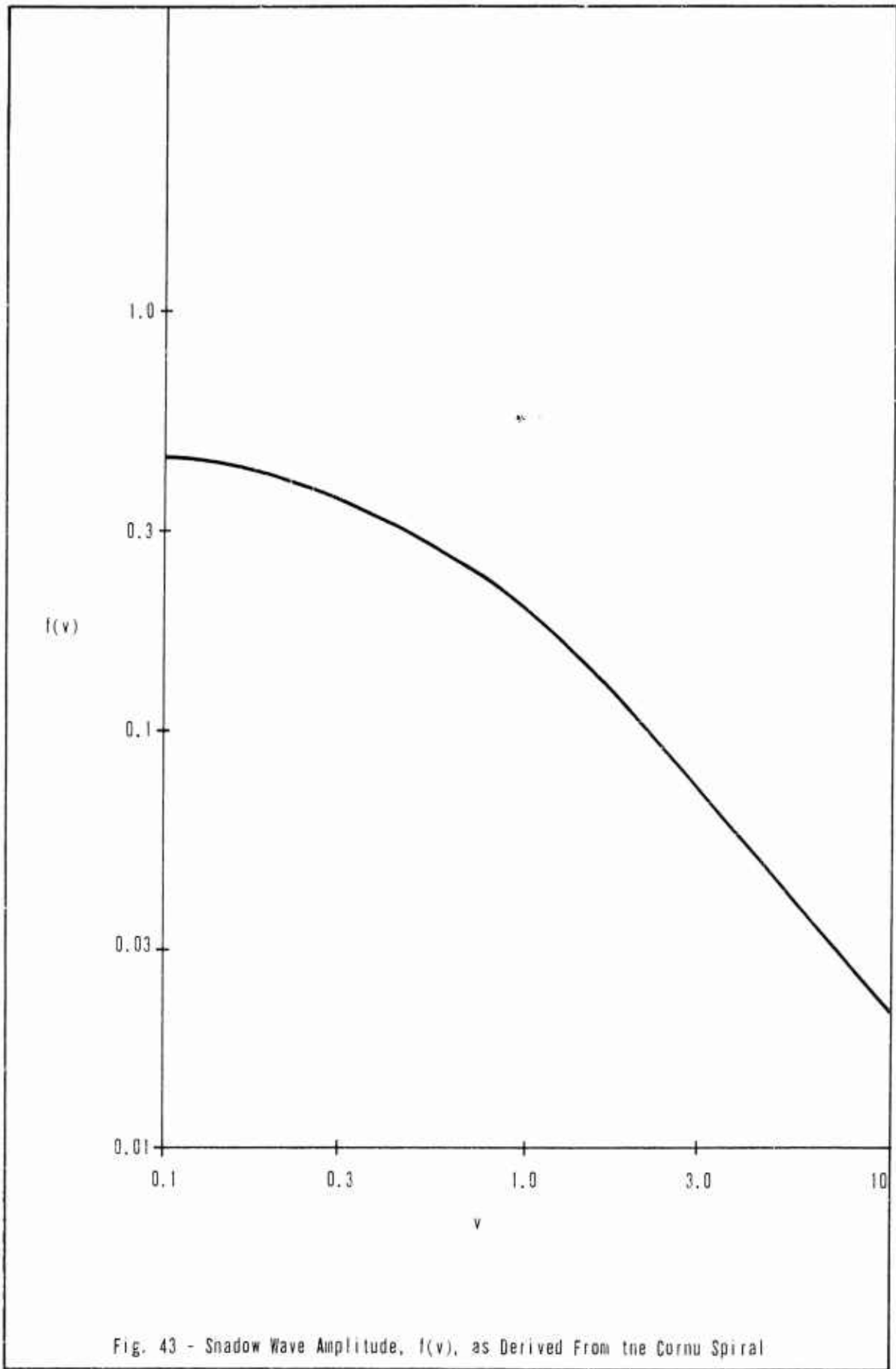

Fig. 43 - Shadow Wave Amplitude,  $I(v)$ , as Derived From the Cornu Spiral

At a smaller range length, the ramp will become more effective. For instance let

$$H_R = 100 \text{ feet}$$

$$H_T = 20 \text{ feet}$$

$$\lambda = 1 \text{ foot}$$

$$R = 1400 \text{ feet}$$

$$S = 50 \text{ feet}$$

$$\phi = 10^\circ$$

then

$$\psi_1 = 30 \text{ milliradians}$$

$$\psi_2 = 290 \text{ milliradians}$$

$$\psi_3 = 260 \text{ milliradians}$$

and

$$v_1 = 0.594$$

$$v_2 = 5.7$$

$$v_3 = 5.1$$

$$E_{\text{ridge}} = 0.54 E_D = -5 \text{ db}$$

$$E_{\text{side}} = 0.045 E_D = -27 \text{ db}$$

$$E_{\text{out}} = 0.043 E_D = -27 \text{ db}$$

Finally, a "rollover" frequency may be defined where it is chosen that  $5.4 v^2 = 1$ .

Although this is not exactly the 3 db point for (6), it does represent the proper behavior at large values of  $v$  where the wave is decreasing at the rate of 3 db per octave. The resulting frequency formed by combining (1) and (5) for the ridge wave is

$$F_1 = \frac{RC v^2}{8 H_R H_T \sin^2 \phi} \approx \frac{22.8 R}{H_R H_T \sin^2 \phi} \quad (\text{Mc})$$

The ridged ramp becomes effective only considerably above this frequency. All dimensions are in feet. For the aforementioned examples, at R = 6000 feet.

$$F_1 = 2250 \text{ megacycles}$$

and at R = 1400 feet,

$$F_1 = 525 \text{ megacycles.}$$

A similar rollover frequency for the finite width of the ramp may be found in a similar manner, except using (3) and (5):

$$F_3 = \frac{RC H_R H_T v^2}{2 S^2 (H_R H_T)^2} \approx \frac{91.2 R H_R H_T}{S^2 (H_R + H_T)^2}$$

for R = 6000 feet, and S = 50 feet,

$$F_3 = 30.4 \text{ megacycles}$$

for R = 1400 feet, and S = 50 feet,

$$F_3 = 7.1 \text{ megacycles}$$

## B. CONCLUSIONS

These calculations then show that the ramp does not become effective as a method of reducing the ground reflection until well above X-band, depending of course upon the parameter values chosen. For best results with a ramp as large a ramp angle as possible must be used with a sufficiently wide ramp surface. The higher the antennas, and also the shorter the range, at a given frequency the better the ramp will perform. As the frequency is decreased the ramp becomes less effective.

Thus it appears that the ramped range will not serve adequately to allow the mode of operation of the range to change from the reflection mode to a "free space" mode. The ramp cannot eliminate the effect of the ground surface. However, the use of a moderate ramp -- 10° ramp angle and total width of 100 feet -- is recommended because it will ease two practical problems. It will ease the grading tolerances in the preparation and maintenance of the earth's surface, and it will permit natural drainage without creating the

problems associated with extensive use of culverts and ditches in the critical areas of the range surface. The ridge of the ramp must be prepared to the tolerances implied by the Rayleigh criterion over most of the range length. A concrete "ridgepole" may be desirable.

CHAPTER VIII  
BLOCKING FENCES

A. WAVE DERIVATION

It has long been known that in antenna test ranges, an undesired wave which is reflected from the ground can be attenuated by placing a blocking fence perpendicular to the direction of propagation and near the point of specular reflection between the transmitter and receiver (see Figure 44). A second fence is sometimes added to further attenuate the undesired wave. The presence of these fences, however, does not exclude the possibility that energy will arrive at the receiver antenna by paths other than the direct or line-of-sight path. It will be shown that several undesirable waves exist. Their amplitude and phase will be estimated and an estimate of the lower cut-off frequency given. The nature of the fence edge material affects the amplitude of the wave only for a distance of a few wavelengths.<sup>16,17</sup> Beyond this point, the wave amplitude is independent of the fence material as long as the fence is opaque.

Figure 45 illustrates that, in addition to the direct or primary wave, four possible ray paths exist for energy to travel from a transmitting antenna across the terrain to the receiving antenna in the presence of a ground reflection blocking fence. These are

1. An edge diffraction of the reflected wave.
2. A diffraction in the shadow zone of a near-bounce ground reflection.
3. A diffraction in the shadow zone of a far bounce wave.
4. A diffraction in the shadow zone of a double bounce wave.

As in the section on the ridged ramp, the amplitude  $E_i$  and phase shift  $\phi_i$  of each of these waves is<sup>16</sup>

$$E_i \angle \phi_i = E_o \frac{e^{-j(\beta_1 + \beta_{gi})}}{2\sqrt{5.4 v_i^2 + v_i + 1}} \quad (1)$$

where

$$v_i = a_i \sqrt{\frac{2(R-U)U}{\lambda R}}$$

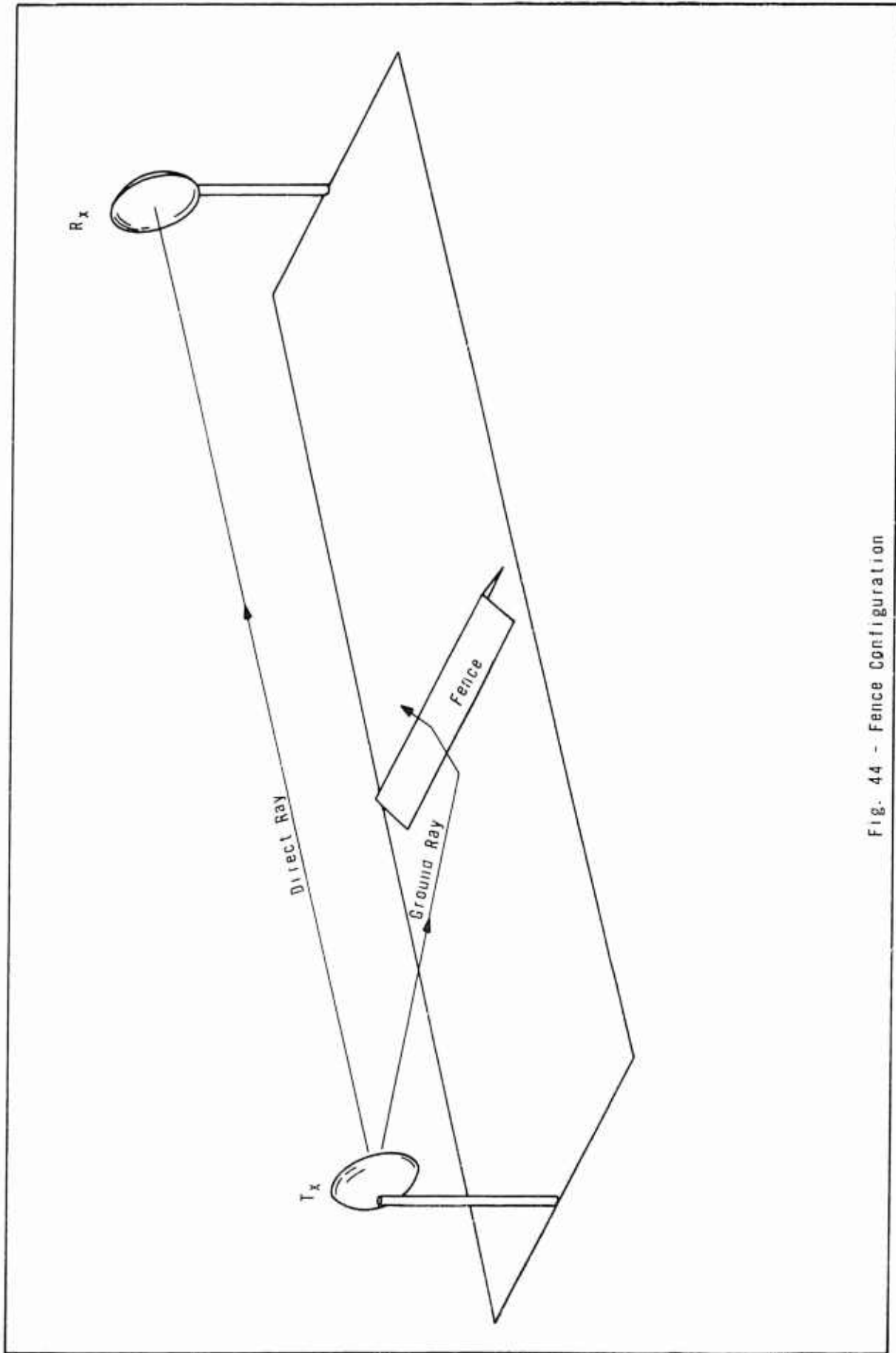

Fig. 44 - Fence Configuration

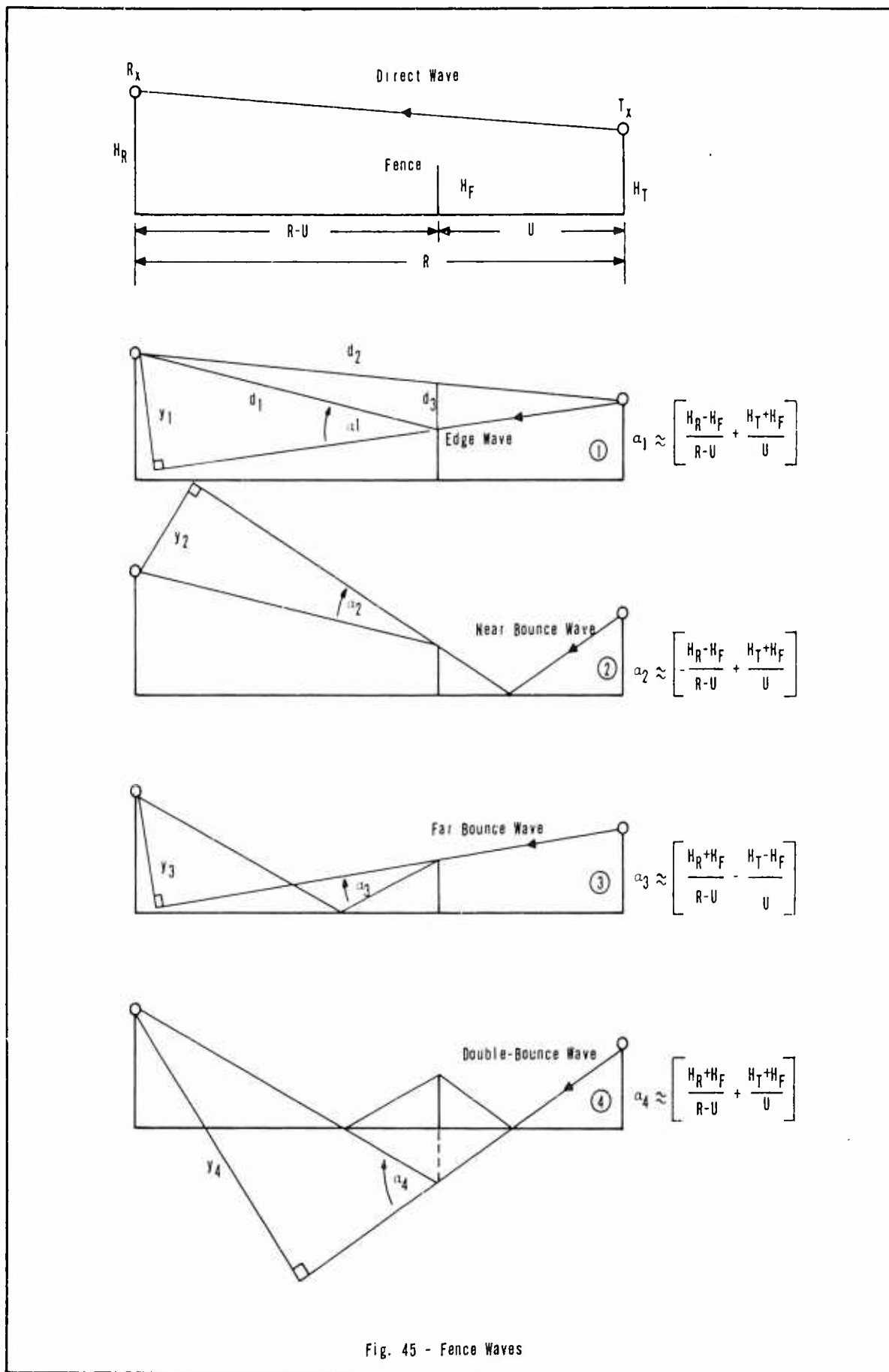

Fig. 45 - Fence Waves

and  $\beta_{gi}$  is the Gouy phase advance characteristic of an edge diffraction. This is

$$\beta_{gi} = \frac{\pi}{4} \left[ 1 - \sqrt{\frac{1}{\pi\beta_1 + 1}} \right] \quad (2)$$

The space phase advance,  $\beta_1$ , is

$$\beta_1 = \frac{4\pi f_i}{\lambda} = \frac{\pi U (R-U)}{\lambda R} \alpha_i^2 \quad (3)$$

where

$$f_i = \frac{d_1 - d_2}{2} \quad (4)$$

Equation (3) is an approximation for the case where  $H_T$ ,  $H_R$ , and  $H_F$  are all much smaller than  $U$ , the distance from the fence to the transmitter antenna.

The angle  $\alpha_i$  is the diffraction angle between the initial ray and the final ray. In terms of the parameters

- $H_T$  = transmitter antenna height, feet
- $H_R$  = receiver antenna height, feet
- $H_F$  = fence height, feet
- $R$  = range length, feet
- $U$  = distance from fence to transmitter antenna, feet
- $\lambda$  = wavelength, feet.

a rollover frequency may be defined where

$$5.4 v^2 = 1,$$

that is

$$F_i = \frac{CR v_i^2}{2\alpha_i^2 (R-U) U} \approx \frac{91.2 R}{\alpha_i^2 (R-U) U}$$

The respective values of  $\alpha_i$  are

$$\begin{aligned}
 \alpha_1 &= \frac{H_R - H_F}{R - U} + \frac{H_T - H_F}{U} \\
 \alpha_2 &= -\frac{H_R - H_F}{R - U} + \frac{H_T + H_F}{U} \\
 \alpha_3 &= \frac{H_R - H_F}{R - U} - \frac{H_T - H_F}{U} \\
 \alpha_4 &= \frac{H_R + H_F}{R - U} + \frac{H_T + H_F}{U}
 \end{aligned} \tag{5}$$

The respective values of  $v_i^2$  are

$$\begin{aligned}
 v_1^2 &= \frac{2(R-U)U}{\lambda R} \left[ \frac{H_R - H_F}{R - U} + \frac{H_T - H_F}{U} \right]^2 \\
 v_2^2 &= \frac{2(R-U)U}{\lambda R} \left[ \frac{H_R - H_F}{R - U} + \frac{H_T + H_F}{U} \right]^2 \\
 v_3^2 &= \frac{2(R-U)U}{\lambda R} \left[ \frac{H_R + H_F}{R - U} - \frac{H_T - H_F}{U} \right]^2 \\
 v_4^2 &= \frac{2(R-U)U}{\lambda R} \left[ \frac{H_R + H_F}{R - U} + \frac{H_T + H_F}{U} \right]^2
 \end{aligned} \tag{6}$$

The total wave is then

$$\begin{aligned}
 E_{\tau} \angle \phi_{\tau} &= E_0 \left[ 1 - \frac{e^{-j(\beta_1 + \beta_{g_1})}}{2 \cdot 5.4 v_1^2 + v_1 + 1} + \frac{e^{-j(\beta_2 + \beta_{g_2})}}{2 \cdot 5.4 v_2^2 + v_2 + 1} \right. \\
 &\quad \left. + \frac{e^{-j(\beta_3 + \beta_{g_3})}}{2 \cdot 5.4 v_3^2 + v_3 + 1} - \frac{e^{-j(\beta_4 + \beta_{g_4})}}{2 \cdot 5.4 v_4^2 + v_4 + 1} \right]
 \end{aligned} \tag{7}$$

The direct wave amplitude is independent of frequency. Each of the remaining rays have frequency dependent phase shifts and amplitudes. The phase shift, a function of the path length, is difficult to calculate. The amplitude is down a constant 6 db for very low frequencies, and decreases at the rate of 3 db per octave above the rollover frequency  $F_1$ .

Consider the following examples:

	(a)	(b)	(c)	(d)	(e)
$H_R$	120 feet	120 feet	120 feet	120 feet	120 feet
$H_T$	20	20	20	20	20
$H_F$	20	20	10	10	20
R	6000	6000	6000	1400	1400
U	1500	1000	1000	250	250

The rollover frequencies are

	(a)	(b)	(c)	(d)	(e)
$F_1$	160 Mc	270 Mc	116 Mc	24 Mc	59 Mc
$F_2$	4000	270	41	770	84
$F_3$	84	190	430	84	32
$F_4$	25	24	35	8	6

and the minimum useful frequencies  $F_M$  ( $\pm 1.5$  db error) are approximately

	(a)	(b)	(c)	(d)	(e)
$F_M$	40,000 Mc	15,000 Mc	7,000 Mc	11,500 Mc	3,000 Mc

The examples show best performance when the fence is located at the point of specular reflection, with useful results at both R - 6000 feet and R = 1400 feet. The best examples, (c) and (e), are not necessarily optimum, but are only indicators of expected performance.

In example (c), attenuation of about 22 db at 40 Gc could be expected.

If a second fence is added, then the attenuation of the ground reflected wave on that side of the first fence is substantially increased but waves 1 and 3 are essentially unaffected. Thus the addition of a second fence will give only about a 3 db improvement.

#### B. TOTAL FIELD AT THE RECEIVER

The exact expression for the total field at the receiver is given by (7). This can be best interpreted by a vector diagram as shown in Figure 47. The exact values of  $\beta_1$  and  $\phi_1$  can only be calculated by the precise determination of the individual path lengths. The individual vectors will not necessarily rotate at the same rate as the receiver height is varied, hence the shape of a vertical profile of field strength will be a complex wave. This also applies to the phase variation. It is possible to determine the zero-to-peak amplitude and phase variation by finding the particular values of each wave from Figure 46. Thus, at 10 Gc,

$$\begin{aligned} E_1 &= 0.045 E_0 \\ E_2 &= 0.022 E_0 \\ E_3 &= 0.071 E_0 \\ E_4 &= 0.020 E_0 \\ \sum_i &= 0.158 E_0 \Rightarrow -16 \text{ db} \end{aligned}$$

If all the waves were in phase, then a zero-to-peak amplitude increase of 1.3 db occurs. The peak variation can be approximated by

$$\phi_{\max} = \tan^{-1} \frac{\sum E_i}{E_0} \quad (8)$$

This amounts to  $9^\circ$  in the above example. It is conceivable that a region can be found where the zero-to-peak variation is considerably less than this amount.

An experimental example of the use of fences is given by Jasik<sup>18</sup> where the vertical amplitude profile is plotted. See Figure 48.

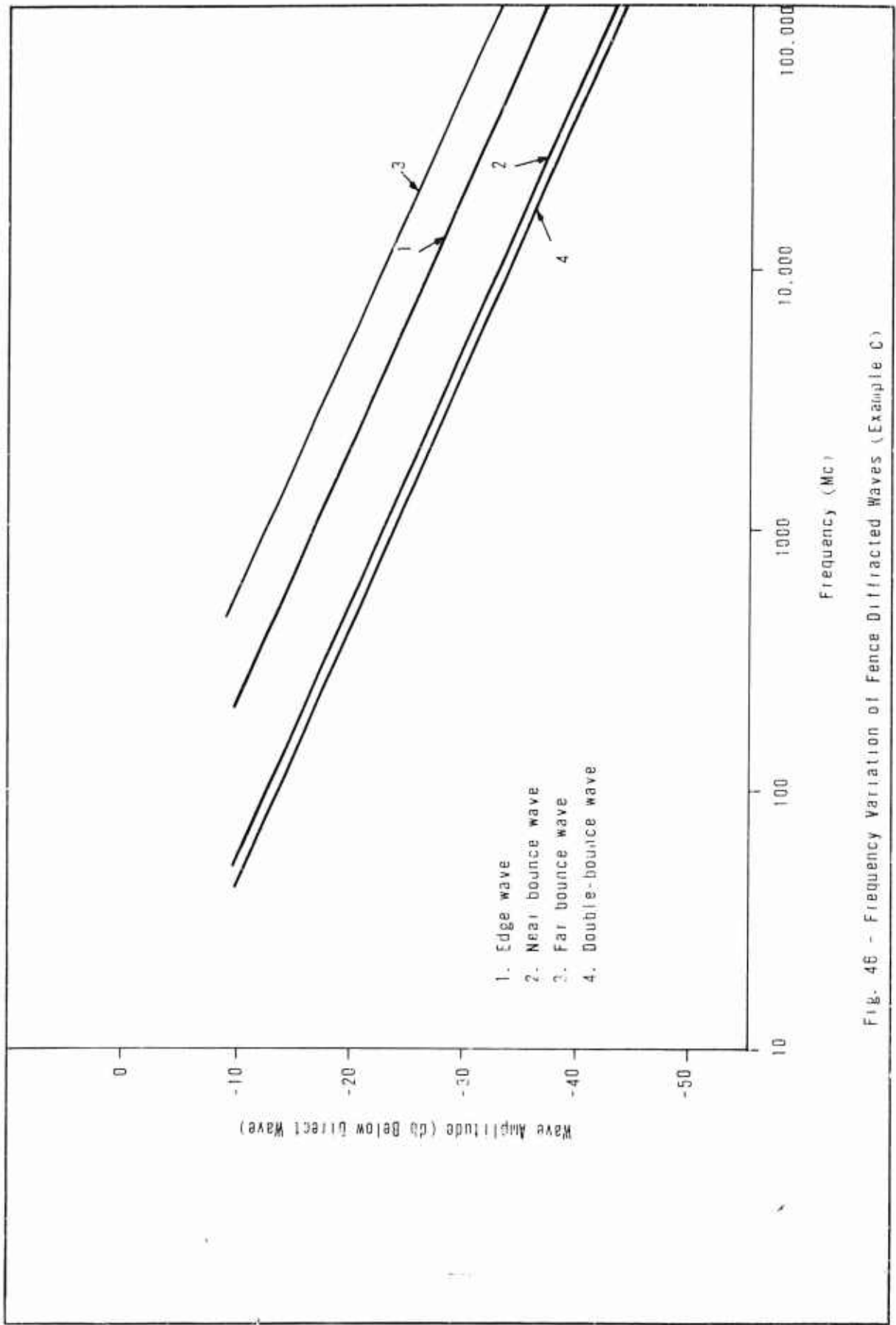

FIG. 46 - Frequency Variation of Fence Diffracted Waves (Example C)

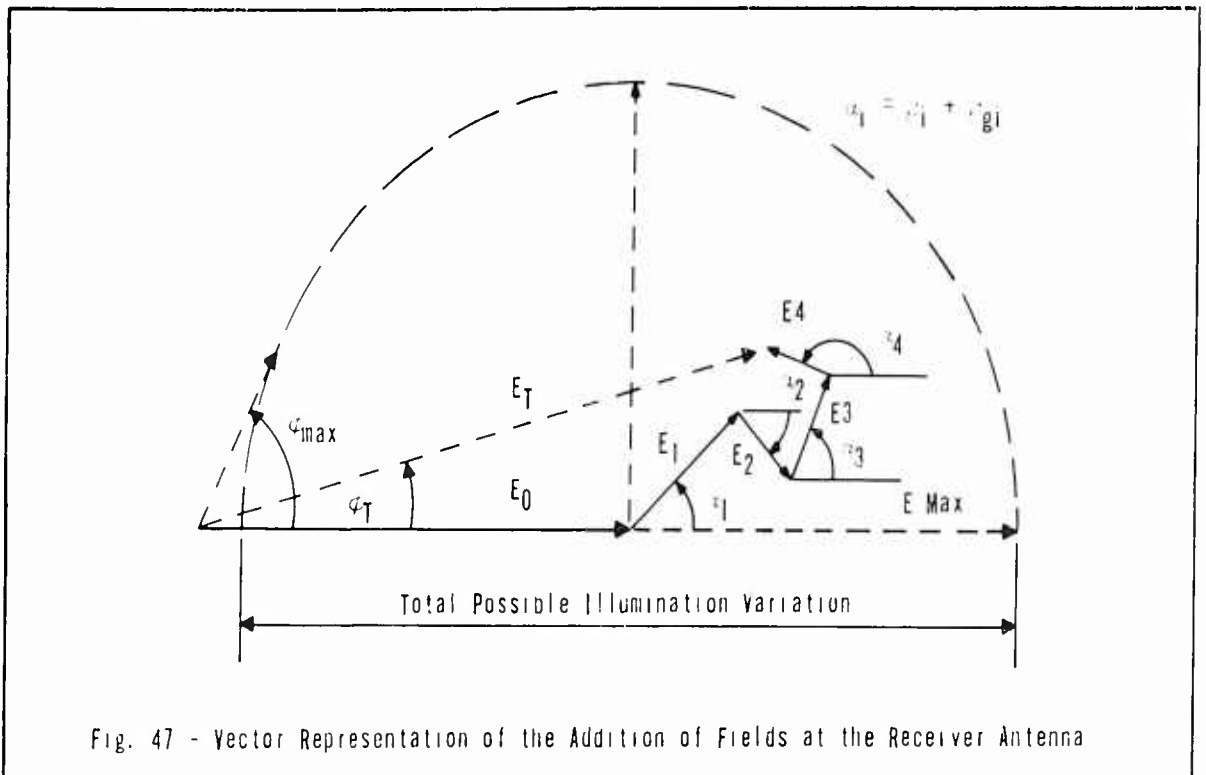

Fig. 47 - Vector Representation of the Addition of Fields at the Receiver Antenna

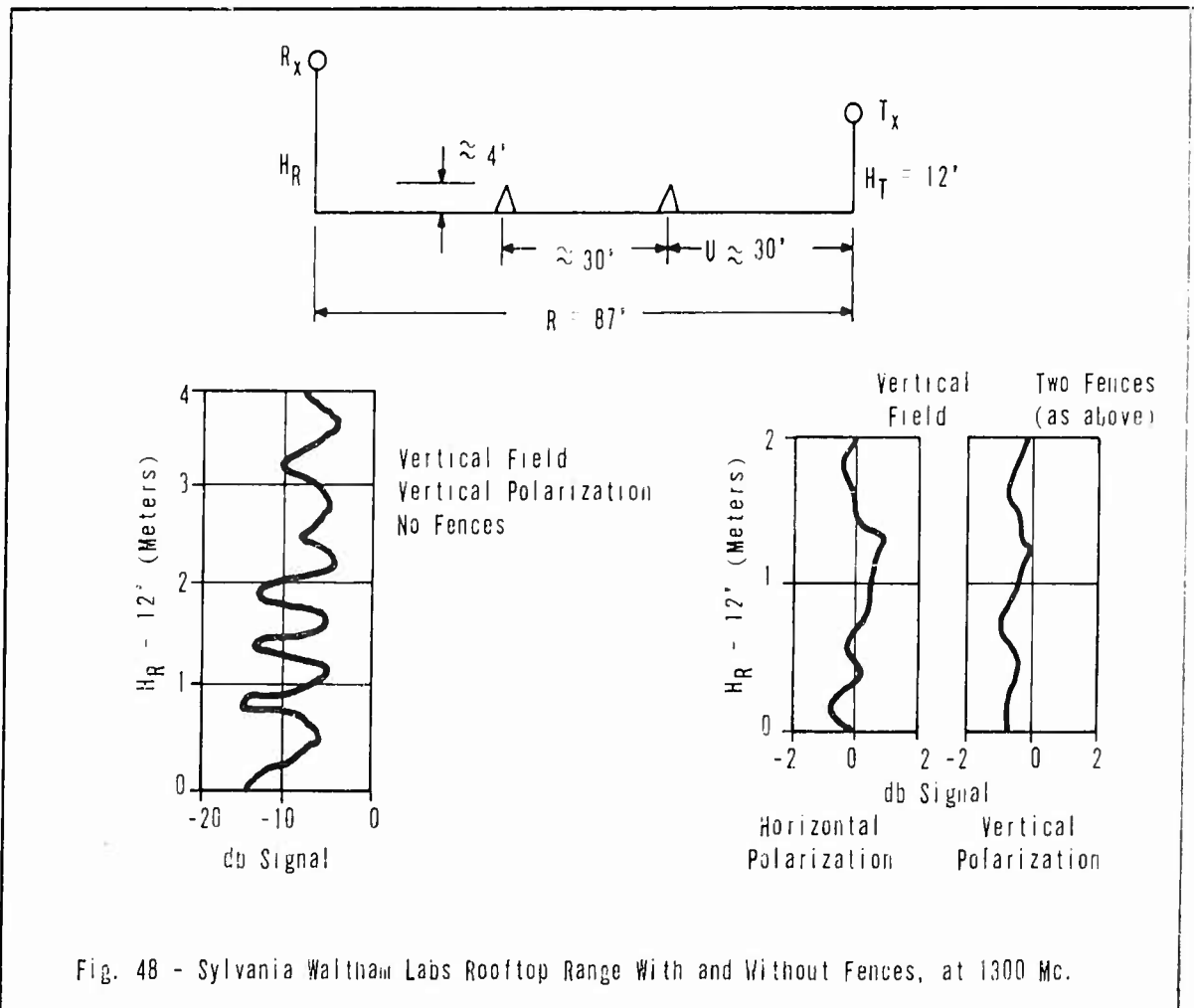

Fig. 48 - Sylvania Waltham Labs Rooftop Range With and Without Fences, at 1300 Mc.

### C. CONCLUSIONS

The effective attenuation of ground reflection blocking fences has been determined. For a sample system, the attenuation reaches usable levels only above 7 Gc, with about 22 db attenuation at 40 Gc.

It is possible to eliminate the need for reflection tuning at frequencies above a certain value depending on the illumination constancy required. Tolerable phase and amplitude variation across the test antenna, and actual variation as a result of a non-ideal range surface, must be experimentally determined before it can be known whether a fence is feasible. In any case, reflection tuning will be necessary below X-Band.

CHAPTER IX  
ATMOSPHERIC PHENOMENA

A. INTRODUCTION

The propagation of an electromagnetic wave through a medium is determined by the index of refraction characteristic of that medium. The index for air is very nearly that of free space. However, small changes in the index will occur as the temperature, pressure, and water content of the air change. This will lead to variations in the apparent path length from transmitter to receiver for the direct and reflected rays. The higher the frequency the more pronounced the effect may be. This manifests itself at the receiver as a variation in the amplitude and phase of the illumination, even when all other conditions are being held constant.

In the event that the air next to the surface of the range is excessively heated so that its index of refraction is reduced from that of the air above it, a mirage-type of reflection may occur. This provides a limiting case that is amenable to analysis and shows that mirages will most certainly affect measurements from S-band up. Problems with atmospheric instability when making high accuracy measurements will show up long before mirages occur. The atmosphere and moisture content of the earth's surface is generally most stable in the early morning hours.

B. ANALYSIS OF MIRAGES

Mirages are essentially internal reflections and should obey the laws thereof. These predict both the critical angle for reflection as well as subsequent phase shifts.

The condition for an internal reflection, see Figure 48, to occur is that angle of incidence satisfy the relation that

$$\sin \theta_m = \frac{n_1}{n_2} \quad (4)$$

where

$n_1$  = index of refraction of the surface air

$n_2$  = index of refraction of the upper or direct path  
air which is approximately equal to 1.0003.

Since the grazing angle,  $\gamma$ , is of more interest here, let  $\gamma_m = (\frac{\pi}{2} - \theta_m)$  and, anticipating that  $\gamma$  will be very small,

$$\cos \gamma_m \simeq 1 - \frac{\gamma_m^2}{2} \simeq \frac{n_1}{n_2}$$

The critical grazing angle in radians is

$$\gamma_m \simeq \sqrt{2 \left(1 - \frac{n_1}{n_2}\right)} \quad (5)$$

Remembering that the index of refraction of air is very nearly unity, (5) can be approximated by

$$m \simeq \sqrt{2 (n_2 - n_1)} \quad (6)$$

The behavior of the refractive index with temperature and pressure is approximated by<sup>19</sup>

$$(n-1) = \frac{C}{T} \left( p + \frac{eB}{T} \right) \times 10^{-6} \quad (7)$$

where

$C = 79^\circ\text{K/millibar}$

$p =$  air pressure, millibars

$B = 4800^\circ\text{K}$

$e =$  water vapor partial pressure

$T =$  air temperature, degrees Kelvin.

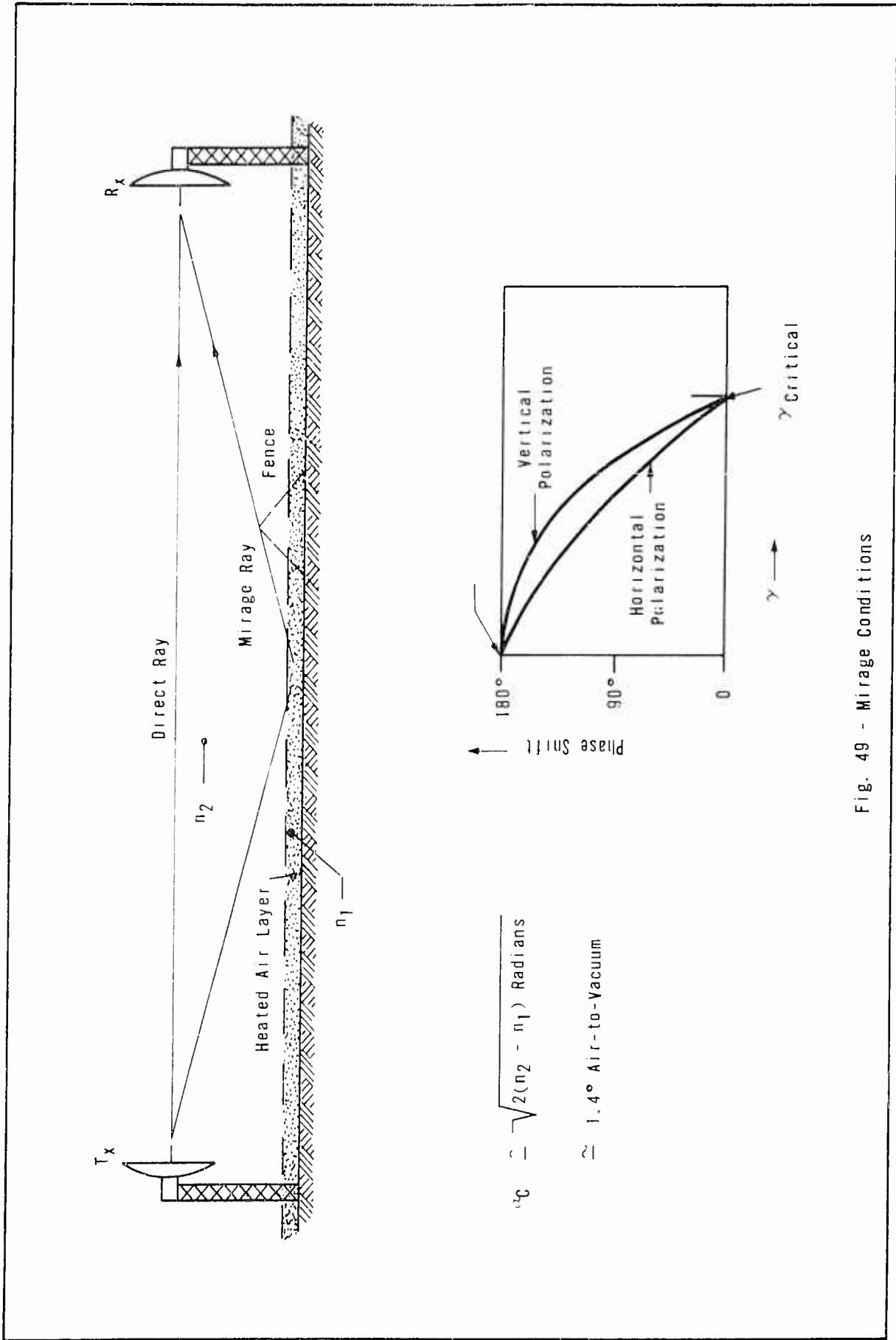

Fig. 49 - Mirage Conditions

This shows that the index increase over unity varies inversely as the temperature when the water vapor is neglected. Assuming that the worst possible case of surface heating would cause a  $50^{\circ}$  C rise in temperature, the change of density would be  $\frac{50}{300} = \frac{1}{6}$ . Hence (6) becomes

$$\gamma_m = \sqrt{2\left(\frac{0.0031}{6}\right)} = 0.01 \text{ Radians} = 0.54^{\circ}.$$

This corresponds to an antenna height of 25 feet on a 5000 foot range. The depth of this layer is of some concern, for the wave will penetrate slightly beyond the interface itself. The wave amplitude will be about 1% of its original value at a distance of one wavelength into the rarer medium<sup>20</sup>. One can assign a "skin depth" of about a quarter of a wavelength, accordingly. Thus, if the heated layer were one inch deep, then waves at frequencies above three kilomegacycles would be susceptible to mirage reflections. The effect of refraction in a thermal gradient is slightly different in that a lesser temperature difference distributed over a finite depth can produce a "total" reflection analogous to the refraction of sound waves by thermal gradients in the deep ocean.

For angles of incidence beyond the critical angle, or alternatively, for values of the grazing angle smaller than  $\gamma_m$ , a totally reflected wave will undergo a phase shift. Just at the critical angle, the phase shift of the reflected wave is the same as that of the incident wave (this should also apply to a thermally refracted wave.) Beyond this value (smaller grazing angles) the phase will progress to  $180^{\circ}$  phase shift.<sup>21</sup> Figure 48 plots this phase shift versus the grazing angle. Note that the shift for a vertically polarized wave progresses more quickly than for a horizontally polarized wave. This means that a vertically polarized wave will undergo more radical phase changes with angle of incidence in the mirage and perhaps also in the case of severe refraction.

CHAPTER X  
TRANSMITTER POWER REQUIREMENTS

A. FACTORS INVOLVED

The power required from the transmitter will depend upon the sensitivity of the receiving system, the signal-to-noise ratio required to hold the chart recorder errors to the desired level, the dynamic range in the antenna pattern to be recorded, peak gain of the antenna under test, the path attenuation, the transmitter antenna gain and RF cable losses.

B. PATH LOSS

The propagation factors will be examined first. The magnitude of the incident Poynting vectors at the receiver antenna from the transmitter is

$$S = \frac{P_{in} G_T}{4\pi R^2} \quad (1)$$

where

$P_{in}$  = power input to transmitter antenna

$G_T$  = transmitter antenna gain with respect to an isotropic source

$R$  = range distance between antennas.

Considering the power received to be dissipated in a matched receiver load, the magnitude of the power in the load is the product of the incident Poynting vector and the effective receiving aperture, where

$$G_R = \frac{4\pi}{\lambda^2} A_R \quad (2)$$

or

$$A_R = \frac{\lambda^2 G_R}{4\pi}$$

with

$G_R$  = receiver antenna gain with respect to an isotropic source

$A_R$  = effective aperture of receiving antenna.

The power dissipated in the receiver load would then be:

$$\begin{aligned} P_{\text{rec}} &= |S| A_R \\ &= \frac{P_{\text{in}} G_T}{4\pi R^2} \frac{\lambda^2 G_R}{4\pi} \\ P_{\text{rec}} &= P_{\text{in}} G_T G_R \left( \frac{\lambda}{4\pi R} \right)^2 \end{aligned} \quad (3)$$

The path attenuation,  $a$ , with isotropic antennas is given by

$$a = \left( \frac{4\pi R}{\lambda} \right)^2$$

The ratio of the power into the receiver to the power into the transmitter is then

$$\begin{aligned} \frac{P_{\text{rec}}}{P_{\text{in}}} &= G_T G_R \left( \frac{\lambda}{4\pi R} \right)^2 \\ &= \frac{4\pi}{\lambda^2} A_T \cdot \frac{4\pi}{\lambda^2} A_R \left( \frac{\lambda}{4\pi R} \right)^2 \\ &= \frac{A_T A_R}{\lambda^2 R^2} \end{aligned} \quad (4)$$

The Fraunhofer criterion, relating antenna size to minimum range length, is expressed in its most general case as:

$$R_{\min} = \frac{2a (D_R + D_T)^2}{\lambda} \quad (5)$$

where

$R_{\min}$  = minimum antenna separation

$D_R$  = maximum receiver antenna dimension

$D_T$  = maximum transmitter antenna dimension

$a$  = a numeric, related to the accuracy of null depth measurement (see Chapter II B).

The path loss from the transmitter antenna input to receiver antenna terminal over the test range may then be expressed by substituting (5) into (4) as:

$$\frac{P_{\text{rec}}}{P_{\text{in}}} = \frac{A_T A_R}{\lambda^2} \left( \frac{\lambda}{2a (D_R + D_T)^2} \right)^2$$

$$\frac{P_{\text{rec}}}{P_{\text{in}}} = \frac{A_T A_R}{4a^2 (D_R + D_T)^4} \quad (6)$$

The power required is independent of frequency since the effective area is a function of the square of the linear dimensions in wavelengths. It is to be seen directly that increasing the accuracy to which null depth can be obtained (increasing the value of  $a$ ) will require increased power.

Consider the case where both antennas are parabolas. The area of a dish is  $\pi D^2/4$ . With a tapered feed for low side lobe levels the effective area will be approximately  $\pi D^2/8$ . Then

$$\frac{P_{\text{rec}}}{P_{\text{in}}} = \frac{\frac{\pi}{8} D_R^2 \frac{\pi}{8} D_T^2}{4a^2 (D_R + D_T)^4}$$

$$= \left( \frac{\pi}{16 a} \right)^2 \frac{(D_R/D_T)^2}{(1 + D_R/D_T)^4} \quad (7)$$

but

$$G = \frac{4\pi A}{\lambda^2} = \frac{\pi^2 D^2}{2 \lambda^2}$$

or

$$D = \frac{\lambda}{\pi} \sqrt{2G} \quad \text{and} \quad \frac{D_R}{D_T} = \sqrt{\frac{G_R}{G_T}}$$

so for parabolas:

$$\frac{P_{\text{rec}}}{P_{\text{in}}} = \left( \frac{\pi}{16 a} \right)^2 \frac{G_R/G_T}{\left( 1 + \sqrt{G_R/G_T} \right)^4} \quad (8)$$

The power ratio from transmitting antenna terminal to receiving antenna terminal, L, may be expressed in db as:

$$L \text{ (db)} = 10 \log \left( \frac{\pi}{16 a} \right)^2 + 10 \log B$$

where

$$B = G_R/G_T \left( 1 + \sqrt{G_R/G_T} \right)^{-4}$$

$$L \text{ (db)} = -15.2 - 20 \log a + B \text{ (db)} \quad (9)$$

The value of B (db) may be determined directly from Figure 49. If the range is operated at  $a = 1$  using parabolas with a 10 db difference in gain, the range loss will be

$$L = -15.2 - 0 - 14.9 = -30.1 \text{ db}$$

Equation (9) applies strictly only for parabolas. From the derivation it may be seen that other types of antennas will complicate the first and last terms. However, the parabola does provide a fairly conservative situation

and the results derived will provide values that are within a few db of being correct for typical antenna tests.

The effective areas and maximum linear dimensions of typical antennas with physical area A are given in Table II.

If a variable length range is used where the transmitter may assume a number of fixed distances, rather than having a free choice of any distance, this will cause the factor  $\underline{a}$  to change. If the distances are 650 ft., 1400 ft., 2800 ft., and 6000 ft. (as will be suggested in the next chapter), these form the ratios.

$$\frac{1400}{650} = 2.15 \quad \frac{2800}{1400} = 2.0 \quad \frac{6000}{2800} = 2.15$$

This results in a maximum variation, due to the contribution of  $\underline{a}$ , to the range loss of 0 to 6.4 db which will have to be considered in determining the power requirement.

### C. POWER REQUIREMENT

The equation for the total power required may be written in db form as:

$$P_T = P_R + S/N + D - G_R - G_T + \alpha + C \quad (10)$$

where

$P_T$  = transmitter power output

$P_R$  = receiver sensitivity in dbm

$S/N$  = signal-to-noise ratio for required accuracy

$D$  = dynamic range of pattern to be measured

$G_R, G_T$  = receiving and transmitting antenna gains

$\alpha$  = path attenuation (frequency dependent)

	$A_E$	$D_{max}$
Horn, max. gain for fixed length	$0.45A$	$\sqrt{A}$
Parabola	$0.5$ to $0.6A$	$\frac{4A}{\pi}$
Metal lens	$0.5$ to $0.6A$	$\frac{4A}{\pi}$
Half-wave dipole	$1.64 \lambda^2$	$.95 \frac{\lambda}{2}$
Yagi	$\frac{11 \lambda^2}{4\pi}$ to $\frac{6 \lambda^2}{\pi}$	$.95 \frac{\lambda}{2}$
Log-periodic	$9$ to $11 \frac{\lambda^2}{4\pi}$	$.95 \frac{\lambda}{2}$
Corner Reflector	$\frac{11 \lambda^2}{4\pi}$	$.95 \frac{\lambda}{2}$

Table II - Effective Aperture and Linear Dimensions

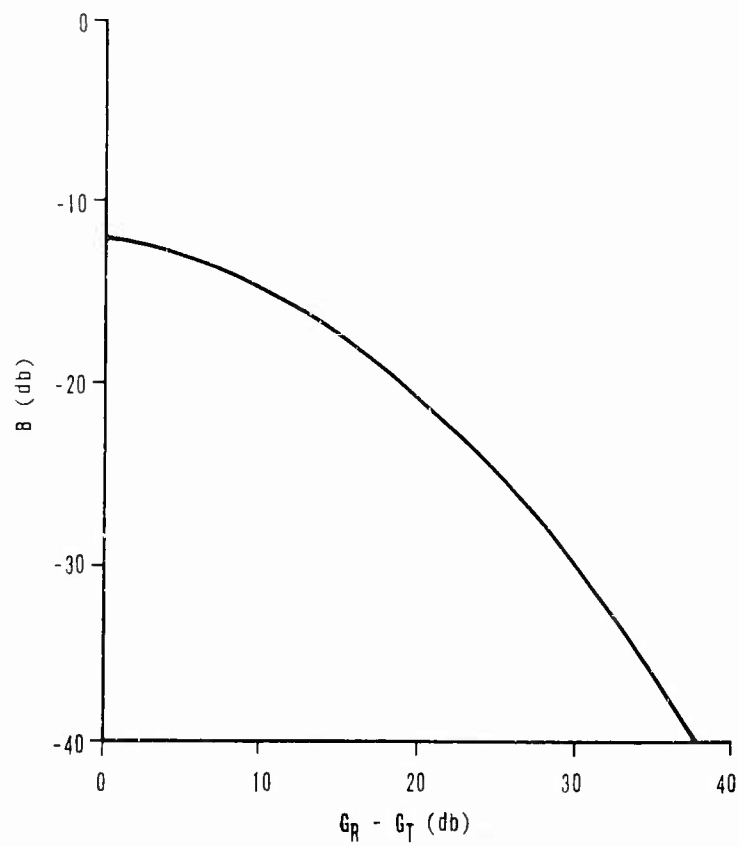

Fig. 50 - Gain Ratio Factor B

C = cable and other fixed system losses

It has been shown that  $\alpha$ ,  $G_R$ , and  $G_T$  can be combined with the Fraunhofer criterion applied resulting in a range loss factor, L, made up of three terms. The first term depends upon the pattern factors, the second depends upon the Fraunhofer null depth term  $\underline{a}$ , and the third depends upon the gain ratio. The power requirement equation can then be written as

$$P_T = P_R + S/N + D + 10 \log \left( \frac{\pi}{16} \right)^2 - 10 \log a^2 + B + C \quad (11)$$

If the bandwidth requirement of the system is reasonable, (and it is as will be discussed in a later chapter) a sensitivity of -100 db may be attained with good engineering practices across the frequency band.

To keep the recorded error less than 1 db a signal-to-noise ratio of 25 db is required. It is specified that antenna pattern measurements of 60 db dynamic range are to be made. Normal good engineering practice requires at least 40 db.

A four station range introduces variation in  $\underline{a}$  resulting in a range loss variation of 0 to 6.4 db. When the range is operating in the reflection mode with  $\rho = -1$ , the image will effectively provide 3 db additional gain. However the reflection mode may not prove effective at the upper end of the frequency range so this factor can not be included in this region where the power becomes most difficult to obtain.

The remainder of the path loss is dependent upon the pattern factors and the ratio of gains for the two antennas. The pattern factor for two parabolas introduces 15.2 db. If the phase and illumination characteristics of the field are to be maintained, the maximum transmitter dimension is limited to 0.414 the maximum receiver dimension. This implies that the gain of the transmitter antenna must always be 7 db, or more, less than the gain of the antenna under test. The contribution of the gain ratio factor, B, will then always be at least 15 db. A reasonable upper bound for this factor would be 25 db. This probably means that there will have to be at least two sets of transmitting antennas available for any frequency range where very high gain (40 to 60 db) antennas are to be tested.

Note that equation (11) is not frequency dependent of itself. However, the gain of a broadband transmitting antenna may be a function of frequency. The gain of an antenna under test may vary when it is tested at nondesign frequencies. And there may be up to 3 db increase in effective transmitter gain due to its image. This gain will not be included because it is variable, depending upon the grazing angle, surface roughness, surface moisture content, and frequency.

The factors can now be combined to determine the power requirements.

Sensitivity	-100 dbm
S/N	25 db
Dynamic Range	60 db
Combined pattern factor	15.2 db
Gain ratio factor	15-25 db
Variation of <u>a</u> (4-station range)	6.4 db
Cable losses	*
	<hr/>
	-8.4 to + 1.6 dbw

\* depends upon system

Thus it appears that the power requirements are very reasonable. Ten watts across the 40 Mc to 40 Gc range should provide an adequate margin.

## CHAPTER XI

### THE TRANSMITTER UNIT AND RANGE SURFACE

#### A. TRANSMITTER RANGE AND HEIGHT

The maximum diagonal available within the confines of the Verona test site is 8000 feet. If a range were constructed of this length, 60-foot apertures could be tested to 1120 Mc as determined by the Fraunhofer equation. However, the alignment of this axis is such that a number of problems are created because of the already existing structures and the terrain. Preparation of the range would be very expensive and even then not all the difficulties could be eliminated. Neither the antenna test range nor some of the other operations at the Verona site would be satisfactory. The most practical alignment results in a 6000-foot range, which will allow 60-foot apertures to be tested to 820 Mc with no degradation in the desired performance of the range, and which will allow the present functions of the site to continue with the least interruption.

For a given range and given receiver height, the height of the transmitter is determined by the reflection range equation:  $4H_R H_T = n \lambda R$ . If the range is operated at a fixed length, the transmitter must be adjustable over a very large range of heights: at 6000 feet, from 312 feet high at 40 Mc, down to 4 inches at 40 Gc. This extreme height results in impractical and unnecessary problems in the construction of the transmitter unit. Also, since the lower frequency standard antennas will have broader beamwidths if they are to be practical, there would be additional problems with undesired energy scattered from the structures already present on the Verona site.

The reflection range equation shows that transmitter height and range length may be varied together. This suggests that the transmitter unit should be allowed to take on more than one position. If a continuously variable range length is considered there immediately arises the problem of providing suitable connections between the receiver building and the transmitter unit. This problem can be taken care of by providing a number of fixed locations for the transmitter unit along the range. Since transmitter height can be varied to compensate for range length, fixed stations are feasible. By making a suitable choice of range lengths, it is possible to meet all desired characteristics with four fixed station positions along the range.

Figure 51 shows the transmitter antenna height as a function of frequency for four range stations located at 650, 1400, 2800 and 6000 feet. These values were chosen in conjunction with a maximum transmitter antenna height of 40 feet to keep the null depth accuracy factor ("a") equal to unity for 60 foot antenna apertures over the frequency range of 40 to 820 Mc. Above 820 Mc the maximum antenna aperture is limited by the 6000 foot range as shown in Figure 52

An upper limit of 30 feet could be used; however, this would require more than four range stations.

Allowing for the possibility that the reflection method would work to 40 Gc, at the 6000-foot range station the antenna height must be variable between 40 feet and 0.39 foot for the  $n = 1$  mode. The small antenna heights at the upper end of the frequency range (15 to 40 Gc) may present some problems. If so, there is the possibility of operation in the  $n = 3$  mode over this upper frequency range with the antenna height then varying between 3 and 1.1 feet. This is a more convenient working height, but operation in the  $n = 3$  mode restricts the maximum receiver antenna aperture to  $0.14 H_R$  when  $H_R$  is mechanically fixed by the receiver building height. For this reason, the antenna structure should be capable of very small antenna heights for testing at the upper frequencies. The  $n = 3$  mode may be used when testing small aperture antennas.

At frequencies above 5 to 10 Gc, problems with inadequate surface tolerances may prevent operating the range using the reflection technique. In this case, fences and ramps will be used and the transmitter height will not be important.

Figure 53 illustrates the difficulties which would arise if care was not taken in the choice on antenna heights and ranges. In this particular case, the transmitter antenna height is limited to 20 feet, and four range stations are located at 300, 600, 2000 and 6000-foot distances. This figure shows that with these parameters, it is impossible to perform Fraunhofer tests on 60-foot receiving antennas (except over very narrow frequency bands) if the null depth accuracy criterion is to be kept at unity. Such a range would be satisfactory for 40-foot (maximum) antennas to 2 Gc.

Figure 54 shows the relationship between transmitter antenna height and frequency for a two-station range with transmitter buildings at fixed ranges of 600 and 6000 feet. This could be constructed with the two ranges at right angles to each other, and a common receiver location. Such a range would

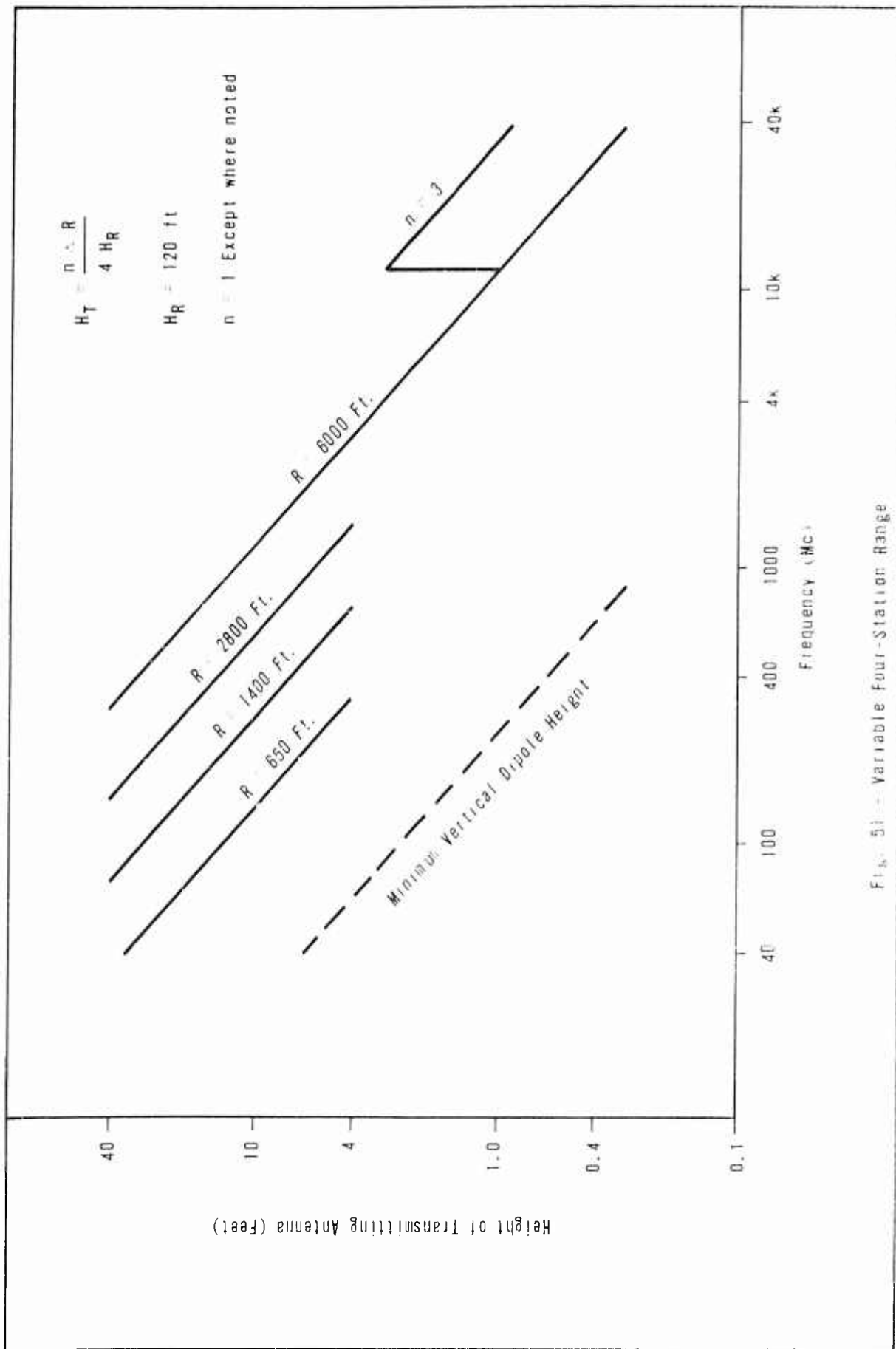

Fig. 51 - Variable Four-Station Range

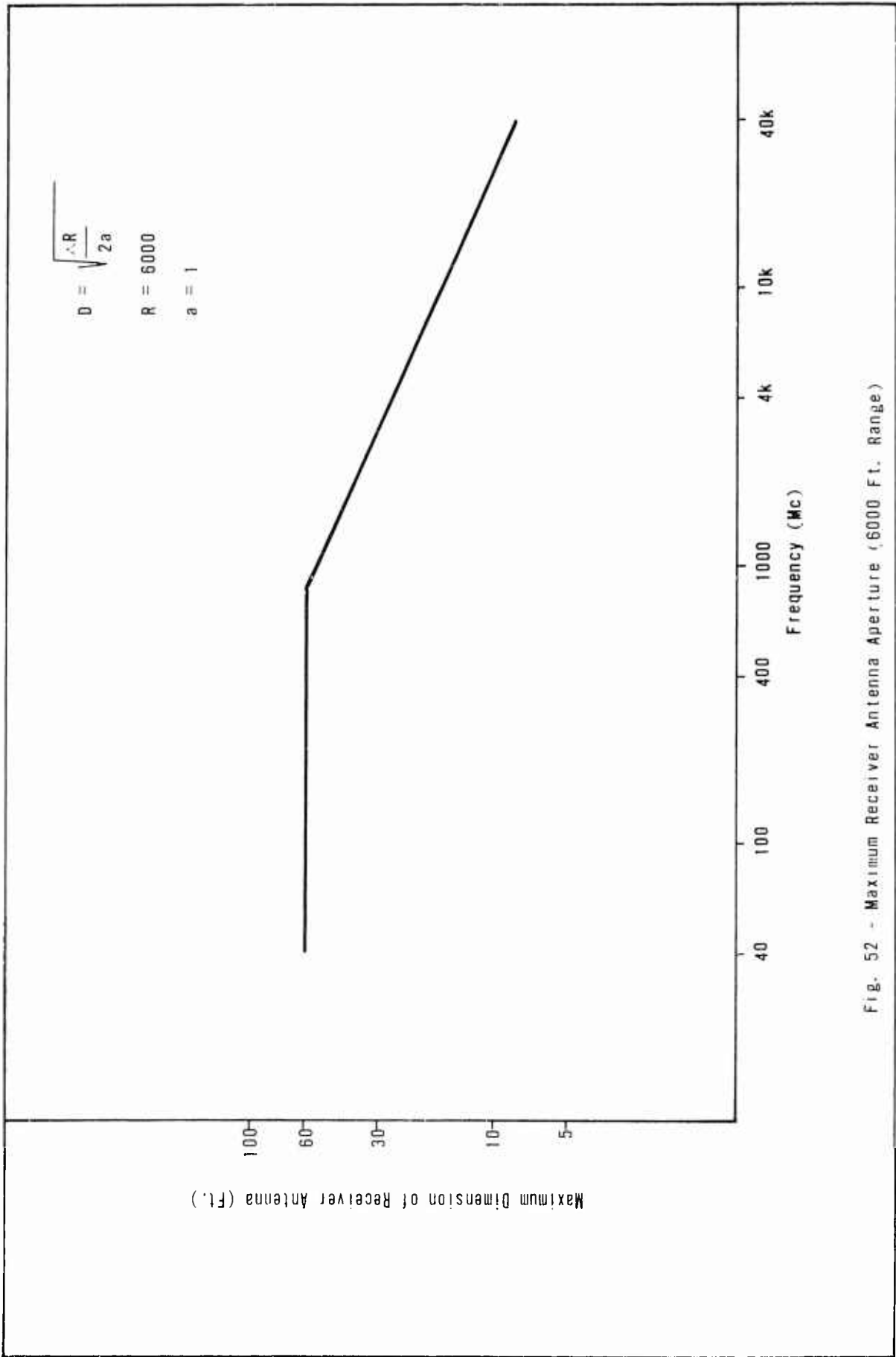

Fig. 52 - Maximum Receiver Antenna Aperture (6000 Ft. Range)

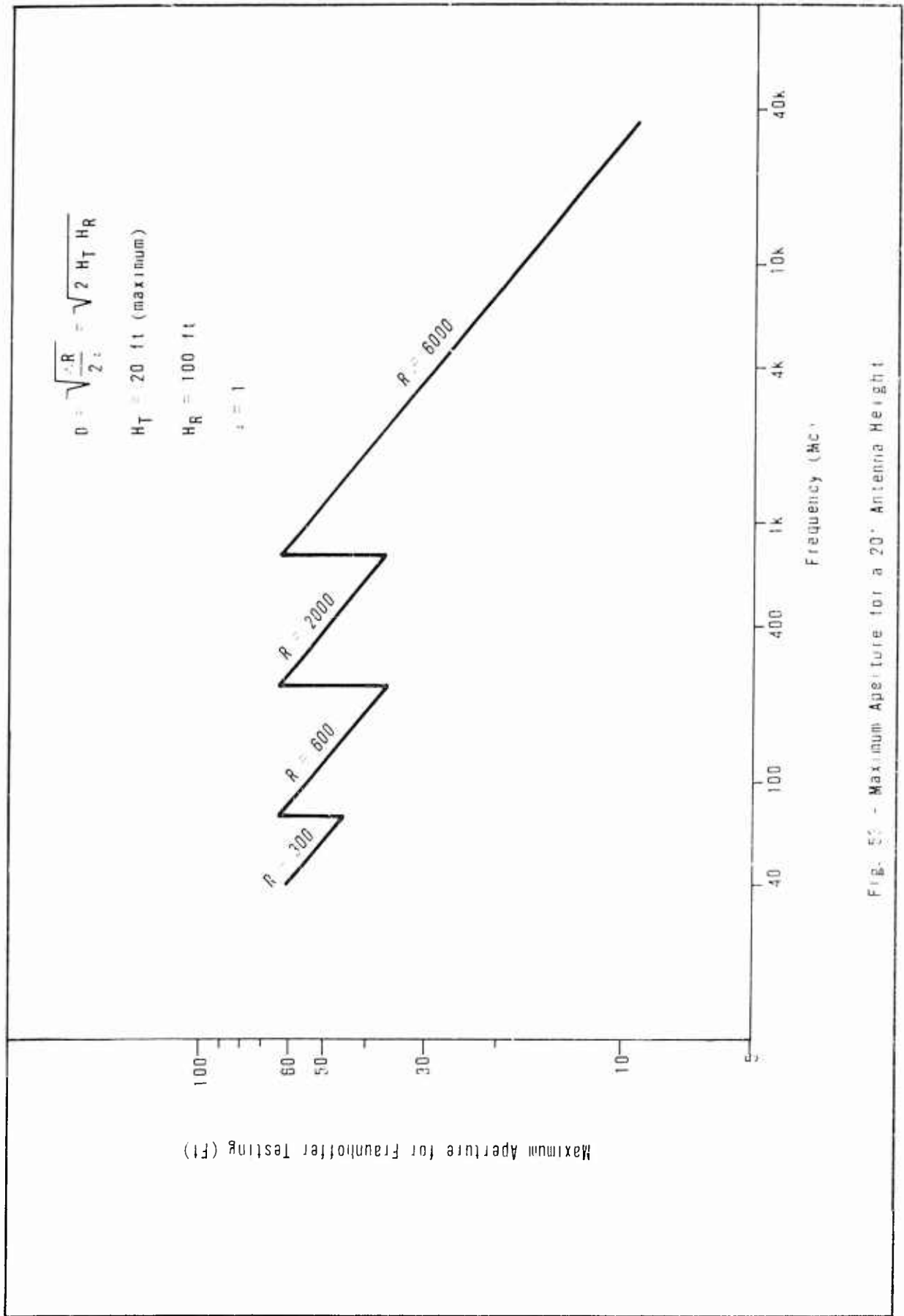

Fig. 53 - Maximum Aperture for a 20' Antenna Height

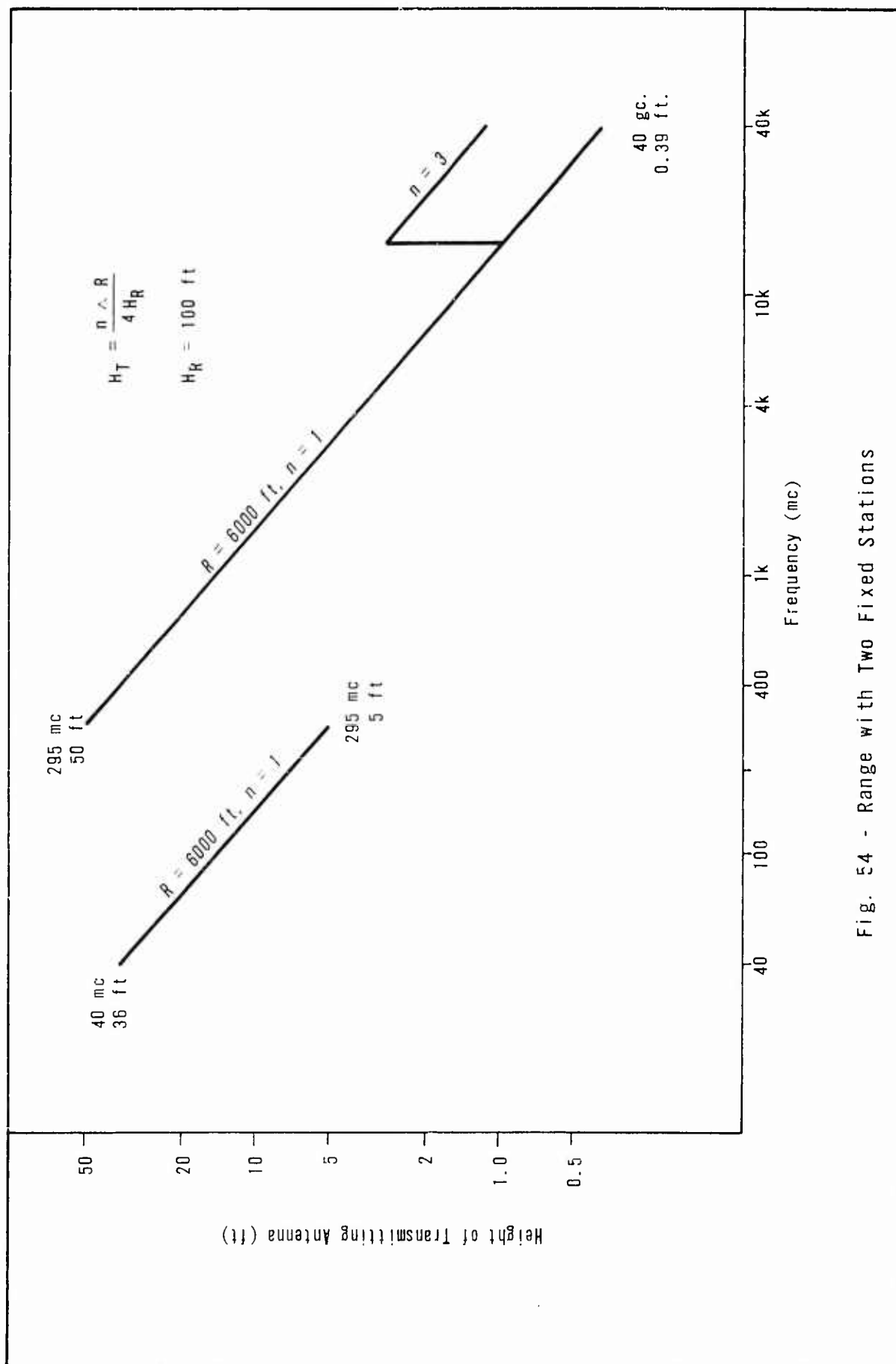

Fig. 54 - Range with Two Fixed Stations

simplify some mechanical problems in a variable length range but would require a maximum transmitter height of 162 feet and the presence of the second range.

## B. ANTENNA CONSIDERATIONS

The transmitter antennas will have a vital effect upon the operation of the range. However, the antennas do not constitute a limiting factor in determining the feasibility of the range. Any problem that may be suggested can be solved by allowing another transmitter antenna. However, in order to keep the range practical and efficient it is desirable to have a minimum number of antennas and a minimum number of antenna adjustments required.

The illumination requirements reflected in the Fraunhofer equation require that the maximum antenna size not exceed 0.41 times the maximum dimension (in the same plane) of the antenna under test. If a limited number of antennas are used, this will determine the maximum size at the upper end of the frequency range for each antenna. The minimum gain of the antenna will determine the transmitter power required at the frequency. Because there will undoubtedly be a wide variation in the gain of the antennas under test, there will probably have to be at least two sets of antennas available for each frequency range, if tests are to be performed over a 60 db dynamic range. Only the lower gain antenna for each frequency range need be a calibrated antenna, since calibration is done in a high gain area of the antenna pattern. The frequency coverage of each antenna should be compatible with its associated RF head.

The gain of the source antenna affects the amount of RF power required. In general, as the frequency increases the gain of the antennas under test will increase. However, even if low gain antennas are tested at high frequencies, power requirements will remain reasonable because a low gain antenna can be tested at a short range.

The source antennas should be linearly polarized so that the normal and cross polarized patterns of the antenna under test can be obtained. This also requires that the antenna mounting bracket be capable of rotating through  $90^{\circ}$ . The lower frequency antennas will have a maximum dimension on the order of one-half wavelength. It can be seen from Figure 51 that there will be no trouble with ground clearance, for the broken line is drawn for a minimum elevation of a vertical dipole at one-half wavelength.

At microwave frequencies, horn antennas are preferred as source antennas. The horn is desirable because of the linearity of its polarization. Depending on the gain needed the parabolic reflector can be used, but due to relatively large off-axis cross-polarized side lobes of paraboloid reflectors (existing under certain circumstances)<sup>22</sup> care must be taken in their use. At VHF and UHF corner reflectors, yagis, or more probably log-periodic antennas can be used. The log-periodic is useful because of the wide bandwidth attainable with this type antenna. The size and weight of the antennas can not be calculated until specific types for specific frequency bands have been chosen. The size and weight of the antennas will determine what type elevating device is needed. One possibility is a self-supporting hydraulic type mast which can be remotely controlled. However, the location of the RF heads must also be considered in making this decision.

If in testing an antenna it is necessary to determine boresight error of the radome to be used with the test antenna, the resulting sway and twist rigidity requirements of the elevated source antenna may be difficult to attain. In some tracking antennas which use a conical scan or monopulse system to produce a well-defined null in the radiation pattern it may be necessary to limit the boresight error to the order of  $0.01^\circ$  or better. Since the proposed site of the antenna test range is in the central part of New York State, high winds and heavy snow and ice conditions can be expected during the winter months. The design of the antennas, the antenna elevating system, and the sway and twist rigidity requirements must take these weather conditions into consideration.

### C. RF UNITS

It has been shown that the RF power requirement is essentially independent of frequency but that it will be affected by the ratio of the gain of the transmitter to the gain of the receiver antenna. Aside from fixed losses in the system, primarily due to RF feed lines, a maximum of 1.4 watts is required across the 40 mc to 40 GC range. After more detailed engineering development the cable losses can be determined. It is now anticipated that the power requirement will be about 10 watts.

The RF units must be capable of being remotely tuned to any frequency within the range of interest. The number of units will be determined by the components available and compatibility with the source antennas. The required

power can be obtained through the use of triode oscillators, low-powered klystrons, and most likely above 1000 mc, a backward-wave oscillator with perhaps a traveling-wave tube amplifier. The frequency stability required will be only that of normal laboratory signal generators, unless a coherent detection scheme is used. In this case it may be desirable to send a pilot signal from the receiver building to the transmitter. To avoid extensive plumbing down the length of the range, the pilot signal would not necessarily be at the transmitted RF frequency. This problem would have to be studied in conjunction with a detailed development of the transmitting and receiving systems. It may represent a complication of the range, but does not restrict the feasibility of the range.

Because of the variable height requirement for the source antenna, the coupling of the RF head to the antenna may pose some engineering problems at the higher frequencies if excessive losses are to be avoided. The simplest solution would be to raise the RF head with the antenna. This will increase the weight to be elevated and so place more stringent requirements on the elevating system, particularly with regard to sway and twist rigidity. However, the maximum elevation required above 1000 Mc is 15 feet so that problems should not be very great.

Below approximately 1000 Mc an FM system is currently being recommended to remove scattered returns. These units will have to be capable of FM modulation over a 2 Mc bandwidth. Above this frequency standard pulse modulation with a 0.4  $\mu$ sec pulse width is required for the Verona site. Either system may be used in the region 500 to 1000 Mc. It would be desirable to have RF heads capable of operating in both modes in this region for cross-checking and experimental purposes.

#### D. TOWER STRUCTURE AND RANGE SURFACE

The transmitter unit is to be movable between range stations at 650, 1400, 2800 and 6000 feet and is to provide antenna heights adjustable from 4 inches to 40 feet. The maximum antenna height may be reduced by providing more range stations. Having fixed range stations simplifies the problem of providing prime power, a pilot signal, trigger signal, and remote control connections. A straight-forward plug-in connection may be used. The maximum antenna height will require a broad-based platform if guy wires are to be avoided. Fixed range stations

will allow permanent jack pads to be installed in the ground which will provide a firm base for outrigger jacks on the transmitter platform.

The method of providing mobility for the platform can have a significant effect upon the performance of the range, particularly at the higher frequencies. Any depression or ridge running the length of the range is going to act as a discrete reflecting or scattering source. If rails are considered, they will be five to ten feet apart. If made of metal they would not have the same reflecting properties as the dielectric earth, even at grazing angles of incidence. For many antennas the angular separation of the rails would be so small that they would not appear in the pattern. But they would contribute to the system error in measuring deep nulls. Also monopulse or other high angular resolution antennas of the future may be able to distinguish the rails, whether of metal or dielectric material, as discrete points in their pattern.

Similarly a wheeled vehicle if continually run over the same path may develop depressions in either a grass or macadam surface unless the total wheel contact area is sufficiently large to keep the surface pressure low. A macadam or concrete strip must necessarily have an edge at some point bordering on grass or other natural surface. This discontinuity will also tend to act as a discrete line source for scattering at the high end of the frequency range which could become troublesome with high angular resolution antennas. There is not enough experimental data available to determine the magnitude of these potential sources. Some model or field experiments are required before a valid recommendation can be made.

These problems are also closely related to the question of the best material for the range surface. Ideally the range would be graded to tolerances better than the minimum required for the highest frequency and covered with a uniform material in an elliptical pattern with the transmitter and receiver being the foci of the ellipse. The size of the ellipse would be such that the scattered returns from the edge of the ellipse would either be sufficiently attenuated by distance that they would be below the maximum tolerable scatter signal at the receiver, or that the time delay from the edge of the ellipse would allow the signal to be removed by the signal processing scheme used at the receiver. The material would be such that the reflection coefficient for both vertical and horizontal polarization is maintained close to minus unity for angles up to  $10^{\circ}$ . Unfortunately no practical material exists with this property that would be economical to use.

At the Verona site the choice will probably be between grass and macadam. Economic considerations will probably dictate that the area graded to close tolerances will be much smaller than the ideal ellipse. Grass will require more annual expenditures than macadam. A relatively narrow macadam strip will provide two discrete edges forming a scattering line and mowing will still be required beyond the hard top. A final decision cannot be made without further electrical and economic considerations. It should be noted that the Lincoln Laboratories antenna test range operates with a grass surface.

#### E. REMOTE OPERATION AND OTHER FACTORS

Remote operation of the transmitter unit should cause no difficulties if the controls are well engineered. The antenna height, polarization and frequency tuning within a band must be quickly adjustable. The extent to which band switching and antenna selection are remotely controlled will probably depend primarily upon economic factors. Additional controls may possibly be required to tune up some of the RF heads. Monitoring circuits for measuring critical transmitter parameters should also be provided. Remote control of the distance to the transmitter unit is probably unnecessary until range utilization factor becomes very high.

The entire transmitter unit will be continuously exposed to weather and so should be built to suitable Mil Specifications. Depending upon the nature of the components and circuits, air conditioning or heating may be required. If it appears desirable to elevate RF heads and power supplies with the antennas, 400 cps power should be considered to reduce the weight. The RF heads should be well shielded, particularly if frequency synthesizing schemes are used, to prevent interference with other activities at the Verona site when the transmitters are on but not radiating out of the antenna. Triggering of the pulsed transmitters should be initiated via cable from the receiver building where the trigger circuits can be tied with suitable delay circuits into a site trigger line. This will allow other radars to be operated on the site while antenna tests are in progress.

## REFERENCES

1. Silver, S. , Microwave Antenna Theory and Design, McGraw-Hill, 1949
2. Krauss, J. , Antennas, McGraw-Hill, 1950
3. Braun, E. , "Gain of Electromagnetic Horns," PROC IRE, Vol. 41, Jan. 1953, pp 109-115
4. Jasik, H. , Antenna Engineering Handbook, McGraw-Hill, 1961, pp. 34.14-34.17
5. Stratton, J , Electromagnetic Theory, McGraw-Hill, 1941
6. Schelkunoff, S , Advanced Antenna Theory, Wiley, 1952
7. Silver, S. , Microwave Antenna Theory and Design, McGraw-Hill, 1949
8. Terman, F. , and J Pettit, Electronic Measurements, McGraw-Hill, 1952, pp 417-419
9. Jenkins, F and H. White, Fundamentals of Optics, McGraw-Hill, 1957
10. Cohen, A. and R. Maltese, "The Lincoln Laboratory Antenna Test Range," MICROWAVE JOURNAL, Vol. 4, April 1961, pp 57-65
11. Mentzer, J. R. , Scattering and Diffraction of Radio Waves, Pergamon Press, 1955
12. Valasek, J , Theoretical and Experimental Optics, Wiley, 1949, pp 172-178
13. Andrews, C. , Optics of the Electromagnetic Spectrum, Prentice-Hall, 1960, pp 283-293, 310-321
14. McDonald and Harris, "Diffraction of Spherical Waves by an Infinite Half-plane," J. OPT. SOC. AMER., Vol. 42, 1952, p. 321
15. Keller, "Diffraction by an Aperture," J. APPL. PHYSICS, Vol. 28, 1957, p. 426
16. Valasek, op. cit. , p 179
17. Andrews, op. cit. , p. 319
18. Jasik, op. cit. , p. 34.17
19. Kerr, Propagation of Short Radio Waves, MIT Rad. Lab. Series, Vol. 13, McGraw-Hill, 1951
20. Andrews, op. cit. , p. 411

REFERENCES (Cont'd)

21. Andrews, op. cit. p. 423
22. Cutler, King and Kock. "Microwave Antenna Measurements" IRE, Vol. 35, December 1947

## BIBLIOGRAPHY

### A. THEORY

1. Ament, W. S. "Reciprocity and Scattering by Certain Rough Surfaces". IRE TRANS AP-8. March 1960 pp 167-174.
2. Barrar, R. B. and Wilcox, C. H. "On the Fresnel Approximation". IRE TRANS AP-6. Jan. 1958 pp 43-48.
3. Cheng, D. K. "Microwave Aerial Testing at Reduced Ranges". WIRELESS ENGINEER. Oct. 1956 pp 234-237.
4. Cheng, D. K. "On the Simulation of Fraunhofer Radiation Patterns in the Fresnel Region". IRE TRANS AP-5 Oct. 1957 pp 399-402.
5. Franz, W. and Klantz, K. "Diffraction by Surfaces of Variable Curvature". IRE TRANS AP-7. Dec. 1959 pp S68-S70.
6. Karp, S. N. and F. C. Karal, Jr. "A New Method for the Determination of Far Fields with Applications to the Problem of Radiation of a Line Source at the Tip of an Absorbing Wedge". IRE TRANS AP-7. Dec. 1959 pp S91-S102.
7. "Mathematical Theory of Antenna Radiation". Quart. Rpt. #3. Nov. 1954 Michigan State College. AD 49 713.
8. "On Minimum Range for Radiation Patterns". Ohio State University, June 1954. AD 35 516.
9. Papadopoulos, V. M. "The Diffraction and Refraction of Plane Pulses". IRE TRANS AP -7. Dec. 1959 pp S78-S87.
10. Spatner, L. M. "A Statistical Model for Forward Scattering of Waves Off a Rough Surface". IRE TRANS AP-6. Jan. 1958 pp 88-94.
11. "Determination of Antenna Gain from Measured Radiation Patterns". Syracuse University. 30 September 1953. RADC-TR 54-25 AD 27 537.
12. "Study of Near-zone Fields of Large Aperture Antennas". Interim Rpt. #1. Syracuse University Research Institute. Oct. 1954. AD 68 054.

13. "Far Field Data at Close Distances", Final Report, Section No. 2  
Technical Research Group. October 1954. AFCRC-TR-54-157  
AD 53 507.
14. Wait, J. R. "Guiding of Electromagnetic Waves by Uniformly Rough  
Surfaces". Part I. IRE TRANS AP-7. Dec. 1959. pp S154-S162.

B. APPLICATION

1. Cumming, W. A. "Radar Measurement at Radio Frequencies: A  
Survey of Current Techniques". PROC IRE, Vol. 47. Mar. 1959.  
pp. 705-735.
2. "Antenna Range Area Construction". Lincoln Laboratory. Mar. 1960.  
AD 237 349.
3. "Analysis and Measurement of Antenna Parameters". Final Report,  
Ohio State University. 14 Nov. 1953. AD 22 560.
4. "A Three-dimensional Pattern Range for Rapid Analysis of Directivity,  
Beam Structure, and Polarization of Wide Beam Antennas". May 1960.  
Scientific-Atlanta, Inc. AD 241 045.
5. Twersky, V. "On Scattering and Reflection of Electromagnetic Waves  
by Rough Surfaces". IRE TRANS AP-5. Jan. 1957. pp 81-90.
6. "Tenth Annual Symposium on USAF Antenna Research and Development  
Program". University of Illinois. Oct. 1960.  
AD 244 388.

C. RADOMES

1. "Analytical and Experimental Studies of Spherical Rigid Ground Radomes."  
Armour Research Foundation. Feb. 1961. RADC TR-60-261.  
AD 254 188.
2. "Investigation of Materials for Lightweight Air-supported Radomes".  
Final Report. Deball & Richardson, Inc. Feb. 1955, RADC-TR-55-23.  
AD 67 183.
3. "Symposium on Rigid Radomes". Vol. 1. Lincoln Laboratory.  
15 October 1958. 296 pp. AD 232582.
4. "The Electrical Evaluation of 110 Foot Diameter Metal Space-frame  
Model Radomes and the CW-415 Radome". Lincoln Laboratory  
April 1961. AD 256 858.

5. "Analysis and Measurement of Transmission Through Radomes", Interim Report. Ohio State University. Feb. 1953. AD 6395.
6. "Simplified Calculation of Antenna Patterns with Application to Radome Problems. Ohio State University. November 15, 1954. AD 51 292.
7. "Effects of Radome Discontinuities on Antenna Patterns". Jan. 1960. Ohio State University. RADC TR-60-75. AD 235 670.
8. "Radomes for Ground USAF Equipments, (Phase I, Air-supported Radomes)". Rome Air Development Center. November 1953. RADC-TR-53-6. AD 22 236.
9. "Electrical Properties of Metal-loaded Radomes". February 1960. Stanford Research Institute. WADD TR-60-84. AD 249 410.

REPORT DISTRIBUTION LIST

<u>Name</u>	<u>No. of Copies</u>
RADC (Project Engineer)	5
RAAPT	1
RAALD	1
ROZMSTT	1
RAIS, Mr. Malloy (For: Sqdn Ldr Tanner)	1
Signal Corps Liaison Officer	1
RADC (RAOL, Maj. Norton)	
Griffiss AFB NY	
AU (AUL)	1
Maxwell AFB Ala	
ASD (ASAPRD)	1
Wright-Patterson AFB Ohio	
Chief, Naval Research Lab	1
ATTN: Code 2021	
Wash 25 DC	
Air Force Field Representative	1
Naval Research Lab	
ATTN Code 1010	
Wash 25 DC	
Commanding Officer	1
USASRD	
ATTN. SIGRA/SL-ADT	
Ft Monmouth NJ	
Chief, Bureau of Ships	1
ATTN: Code 312	
Main Navy Bldg	
Wash 25 DC	
Office of the Chief Signal Officer	1
Dept of the Army	
ATTN: SIGRD	
Wash 25 DC	
AFPRO	1
GE Co	
Lockland Br	
PO Box 91	
Cincinnati 15 Ohio	

REPORT DISTRIBUTION LIST (Cont)

Name	No. of Copies
Chief, AF Section MAAG Germany Box 810 APO 80 New York NY	1
AFSC (SCSE) Andrews AFB Wash 25 DC	1
Commanding General US Army Electronic Proving Ground ATTN: Technical Documents Library Fort Huachuca Ariz	1
ASTIA (TISIA-2) (Not releasable to ASTIA - see Arlington Hall Station AFR 205-43 send the 10 copies Arlington P Va to RADC (RAAPT)	Minimum of 10 copies
Georgia Institute of Technology ATTN: Mr. Bruce Warren Atlanta 13, Georgia	1
Cutler Hammer Airborne Instruments Lab ATTN: Mr. O. F. Henkelman Deer Park, Long Island, New York	1
American Electronics Laboratories, Inc ATTN: Mr. C. J. Fowler Richardson Road Colmar, Pennsylvania	1
University of Pennsylvania ATTN: Proj. O. D. Salati 34 Walnut Street Philadelphia 4, Pennsylvania	1
USASRDL (Mr. S. Wertz) Ft. Monmouth, New Jersey	1
Sylvania Electronic Products ATTN: Mr. J. Whittman 1100 Wherie Drive Buffalo 9, New York	1

REPORT DISTRIBUTION LIST (Cont)

<u>Name</u>	<u>No. of Copies</u>
Electro-Mechanics Co. ATTN: Dr. F. J. Morris P. O. Box 802 Austin 64 Texas	1
Stanford Research Institute ATTN: Dr. L. Young Menlo Park, California	1
American Systems, Inc. ATTN: Mr. R. A. Gerlock 1625 East 126th Street Hawthorne, California	1
Westinghouse Electric Corp. ATTN: Mr. J. Carter P. O. Box 1897 Baltimore, Maryland	1
GEEIA (ROZMWT, Mr. D. R. Clark) Griffiss AFB NY	1
Armour Research Foundation ATTN: Mr. B. Epstein 10 West 35th Street Chicago Illinois	1
ASD (ASRNCS-2, Mr. H. Bartman) Wright Patterson AFB Ohio	1
Electromagnetic Compatibility Analysis Center ATTN: Mr. Benjamin Lindeman US Naval Engineering Experimental Station Annapolis, Maryland	2
Rand Corporation 1700 Main Street Santa Monica, California	1
RADC (RAUMM, Mr. Q. Porter) Griffiss AFB NY	2
Navy Air Navigation Electronics Project Weapons System Test Division (Mr. O. D. Stewart) Naval Air Test Center Patuxent River, Maryland	1

REPORT DISTRIBUTION LIST (Cont)

<u>Name</u>	<u>No. of Copies</u>
Radio Corporation of America ATTN: Mr. A. Matheson PO Box 588 Burlington, Mass.	1
Radiation Incorporated ATTN: Mr. W. F. Quinlivan PO Box 37 Melbourne, Florida	1
Melpar, Inc. ATTN: Mr. W. Myers Falls Church, Virginia	1
US Naval Civil Engineering Laboratory ATTN: Mr. D. Clark Port Huerneme, California	1
Sperry Microwave Electronics Company Division of Sperry Rand Corporation ATTN: Mr. R. W. Smith Clearwater, Florida	1
Bendix Corporation Bendix Radio Division ATTN: Mr. A. E. F. Grempler Powson, Maryland	1
Jansky & Bailey ATTN: Mr. K. G. Heisler, Jr. 1339 Wisconsin Ave. N. W. Washington, D. C.	1
Ohio State University Dept. of Electrical Engineering Antenna Laboratory (Mr. L. Peters, Jr.) Columbus 10, Ohio	1
White Electromagnetics, Inc. ATTN: J. E. McShulskis 4903 Auburn Avenue Bethesda 14, Maryland	1
RADC (RAUA, Mr. A. Feiner) Griffiss AFB NY	1