

UNCLASSIFIED

AD NUMBER

AD287201

LIMITATION CHANGES

TO:

Approved for public release; distribution is unlimited.

FROM:

Distribution: Further dissemination only as directed by Naval Ordnance Test Station, China Lake, CA 93553, SEP 1962, or higher DoD authority.

AUTHORITY

NOTS per DTIC Form 55

THIS PAGE IS UNCLASSIFIED

**UNCLASSIFIED**

---

---

**AD 287 201**

*Reproduced  
by the*

**ARMED SERVICES TECHNICAL INFORMATION AGENCY  
ARLINGTON HALL STATION  
ARLINGTON 12, VIRGINIA**



---

---

**UNCLASSIFIED**

NOTICE: When government or other drawings, specifications or other data are used for any purpose other than in connection with a definitely related government procurement operation, the U. S. Government thereby incurs no responsibility, nor any obligation whatsoever; and the fact that the Government may have formulated, furnished, or in any way supplied the said drawings, specifications, or other data is not to be regarded by implication or otherwise as in any manner licensing the holder or any other person or corporation, or conveying any rights or permission to manufacture, use or sell any patented invention that may in any way be related thereto.

63-1-3

NAVWEPS REPORT 7953  
NOTS TP 2994  
COPY 105

CATALOGED BY ASTIA  
AS AD NO. 287201  
287 201

# ENGINEERING PROPERTIES OF EXPLOSIVELY WORK-HARDENED STEELS

by

George A. Hayes  
and  
John Pearson  
*Research Department*

**ABSTRACT:** An experimental study is discussed in which permanent changes were produced in the engineering properties of four annealed steels (1015, 1030, 1050, and 4130) by means of contact explosive charges of different thicknesses. Quantitative data is presented for explosively induced changes in proportional limit, yield strength, ultimate strength, fracture strength, elongation, and toughness for the four steels as related to charge thickness and distance from the metal-explosive interfaces.

Released to ASTIA for further dissemination with out limitations beyond those imposed by security regulations.



**U. S. NAVAL ORDNANCE TEST STATION**

**China Lake, California**

September 1962

**U. S. NAVAL ORDNANCE TEST STATION**

**AN ACTIVITY OF THE BUREAU OF NAVAL WEAPONS**

**C. BLENNAN, JR., CAPT., USN**  
*Commander*

**WM. B. McLEAN, PH.D.**  
*Technical Director*

**FOREWORD**

This report represents part of a continuing program at this Station in the study of the effects and applications of explosively induced loads as related to metal bodies. These studies were supported by funds under Bureau of Naval Weapons Task Assignments RUME-3-E-026/216-1/WFO08-10-004 and RUME-3-E-000/216-1/F008-10-04.

Portions of this report were included as part of an invited paper presented at the National High Energy Rate Forming Seminar sponsored by the American Society of Tool and Manufacturing Engineers, Detroit, Michigan, 27-28 September 1961.

**T. E. PHIPPS**  
Head, Research Department

Released under  
the authority of:  
WM. B. McLEAN  
Technical Director

NOTS Technical Publication 2994  
NAVWEPS Report 7953

Published by . . . . . Research Department  
Collation . . . . . Cover, 17 leaves, abstract cards  
First printing . . . . . 225 numbered copies  
Security classification . . . . . UNCLASSIFIED

1 Office of Naval Research Branch Office, Chicago  
 1 Office of Naval Research Branch Office, Pasadena  
 1 Operational Test and Evaluation Force  
 1 Bureau of Naval Weapons Representative, Azusa  
 2 Chief of Ordnance  
     ORDTB (1)  
     ORDTS (1)  
 2 Aberdeen Proving Ground  
     Ballistic Research Laboratories (1)  
     Development and Proof Services (1)  
 1 Army Research Office, Durham  
 1 Diamond Ordnance Fuze Laboratory (Library)  
 4 Frankford Arsenal  
     Pitman-Dunn Laboratory (3)  
     Library (1)  
 1 Ordnance Ammunition Command, Joliet (ORDLY-R-T)  
 1 Ordnance Test Activity, Yuma Test Station (A & A Division, S. Cohen)  
 3 Picatinny Arsenal (Library)  
 1 Radford Arsenal  
 1 Redstone Arsenal (Rocket Development Laboratory, Test and Evaluation Branch)  
 1 Rock Island Arsenal  
 3 White Sands Proving Ground (Technical Library)  
 2 Headquarters, U. S. Air Force  
     AFDRD-AN (1)  
     AFDRD-CC (1)  
 1 Tactical Air Command, Langley Air Force Base (TPL-RQD-M)  
 1 Air Force Cambridge Research Laboratories, Laurence G. Hanscom Field  
 1 Air Force Systems Command, Andrews Air Force Base  
 3 Air Proving Ground Center, Eglin Air Force Base  
 1 Air University Library, Maxwell Air Force Base  
 1 Holloman Air Force Base  
 1 AFSC Liaison Office, Aberdeen Proving Ground  
 10 Armed Services Technical Information Agency (TIPCR)  
 1 Defense Atomic Support Agency, Sandia Base  
 1 Weapons Systems Evaluation Group  
 1 Ames Research Center  
 1 Langley Research Center (Library)  
 1 Lewis Research Center  
 4 British Joint Services Mission, Ministry of Supply Staff (Reports Officer) via BuWeps (DSC)  
 4 Defence Research Member, Canadian Joint Staff (W) via BuWeps (DSC)  
 2 Aerojet-General Corporation, Azusa, Calif. (Librarian) via BuWepsRep  
 2 Allegany Ballistics Laboratory, Cumberland, Md.  
 2 Applied Physics Laboratory, JHU, Silver Spring  
 1 Armour Research Foundation, Chicago (Document Librarian for Department M)  
 1 Arthur D. Little, Inc., Cambridge (W. H. Varley)  
 2 Autonetics, A Division of North American Aviation, Inc., Downey, Calif.  
     Department 93, F. H. Gardner (1)  
     Technical Library, 393-53 (1)

## INTRODUCTION

When metal bodies are subjected to the type of loads produced by a contact detonating explosive, they undergo severe changes in their metallurgical and engineering properties. These changes in properties then determine how the metal will behave during a secondary phase of a time-extended load, where the time of load extension may be measured in milliseconds or longer. Thus, changes produced during an initial loading period may affect the metal behavior during the latter part of a loading cycle. Property changes are also important in the materials reaction to subsequent loads where the delay between loads may be measured in milliseconds, hours, days, or even years. Both types of loading concepts (time-extended loads and subsequent loads) are commonly encountered in explosive ordnance applications.

In the metallurgical sense, material changes can be macrostructural or microstructural in nature. Macrostructurally they might appear as shear and tensile fractures, and as dimensional distortion. Microstructurally the metal may undergo severe grain distortion, slip, shock twinning, work hardening, and in a few cases even a transformation in the lattice structure.

The explosive loading also affects the strength and ductility characteristics of the metal so that its engineering properties after loading will be considerably different than before the load was applied. The new strength characteristics determine the type of loads that the explosively worked metal can then undergo without additional deformation or without fracture. The combined strength-ductility behavior is related to the amount of work that can be performed on the metal before fracturing occurs.

This report discusses a series of experimental tests in which four different types of steels (1015, 1030, 1050, and 4130) were impulsively loaded with contact charges of various amounts of high explosive. Quantitative stress-strain data are presented that indicate the changes in engineering properties of these steels as a result of such loads. The effect of steel-buffer thickness on the change in engineering properties in such systems is also indicated. Future reports will discuss changes in hardness and microstructure.

## EXPERIMENTAL PROCEDURE

Explosive work-hardening experiments were conducted with four different steels: 1015, 1030, 1050, 4130. All metals were initially in the form of 1/2-inch x 10-inch x 10-inch hot rolled plates in a fully annealed condition. The surfaces of each plate were ground to insure a uniform thickness (0.480-inch) and surface finish. The chemical analysis and grain size of each steel is shown in Table 1.

TABLE 1. Chemical Analysis and Grain Size of Steels Tested

Steel	Composition, %								Grain size <sup>a</sup>
	C	Mn	P	S	Si	Cu	Cr	Mo	
1015	0.17	0.52	0.01	0.04	0.11	0.09	....	....	7
1030	0.29	0.60	0.03	0.04	0.12	....	....	....	7
1050	0.49	0.66	0.04	0.03	0.17	....	....	....	5
4130	0.30	0.52	0.01	0.01	0.24	....	0.94	0.18	7

<sup>a</sup> Timkin ASTM number.

Figure 1 shows schematically the general test arrangement used to produce permanent changes in steel plates by contact explosive charges. For each test three or four plates of a given steel (the number of plates depending upon the amount of explosive used) were carefully stacked together and mounted on a large steel block which served as an "energy sink" to prevent spalling of the bottom plate due to the reflection of stress waves. All plates were oriented such that the rolling direction of the plate was parallel to the direction of detonation in the explosive. All plates had a ground surface finish and were wrung together to insure tightness of contact.

A layer of one or more sheets of 0.084-inch-thick PETN-base plastic sheet explosive (du Pont, Type EL-506A) was placed in intimate contact with the upper surface of the top plate. A triangular shaped line-wave generator extending in front of the plates was used in an effort to get a more uniform loading along the top surface of the plates. The line-wave generators were initiated with special detonators (du Pont, Type X-332-13) recommended for this explosive.

To produce various loading conditions, different thicknesses of explosive layer were used. Tests were conducted with 1, 2, 4, and 8 sheets

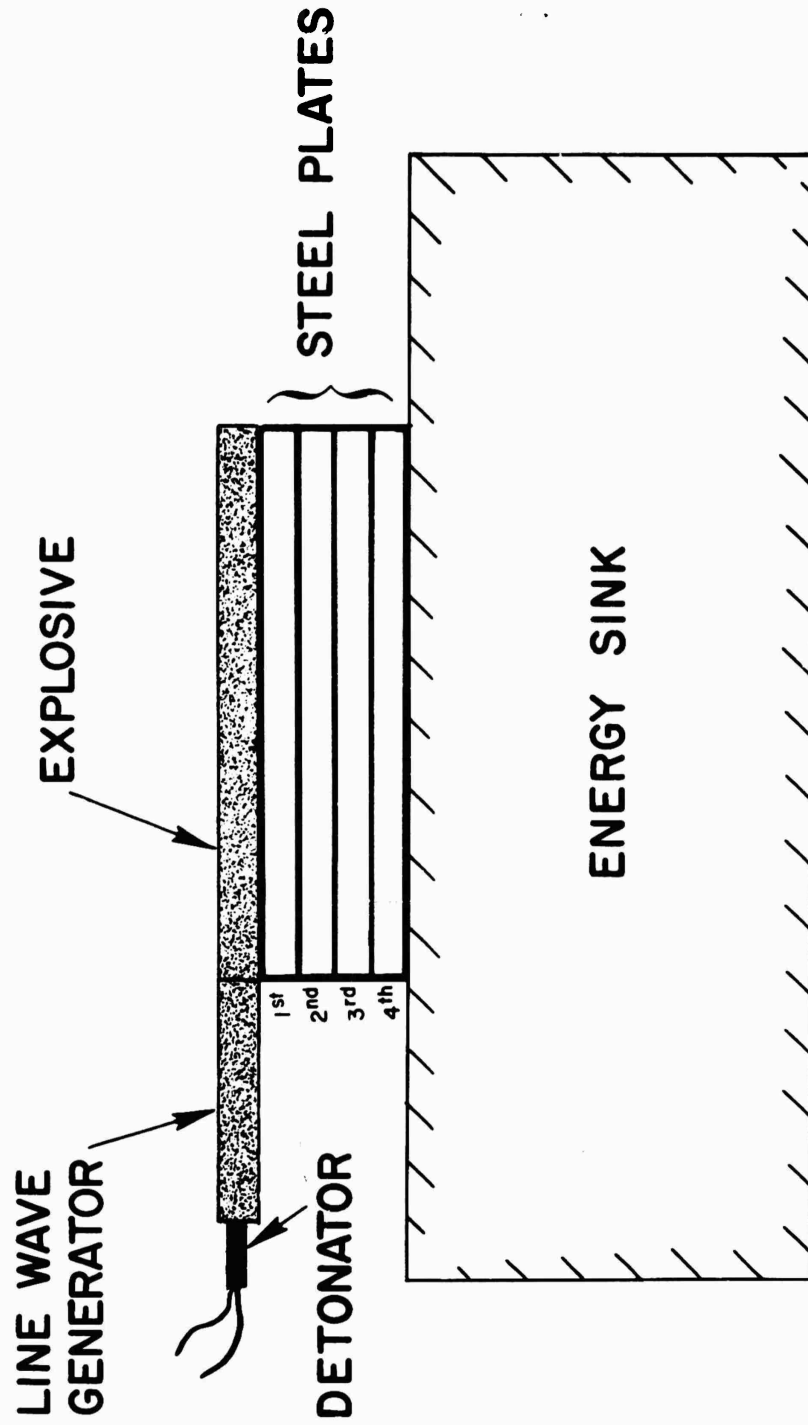

FIG. 1. General Test Arrangement.

of explosive in contact with the top plate, so that the explosive thicknesses were 0.084, 0.168, 0.336, and 0.672 inches, respectively. A total of sixteen tests were conducted. The plates were then studied to obtain data on changes in the engineering properties as a function of charge thickness and distance from the metal-explosive interface.

After explosive loading, two standard ASTM rectangular tension test specimens, 8 inches long with 2-inch gage length, were machined from the central portion of each steel plate, with the rolling direction of the plate parallel to the axis of the specimens. Care was taken to insure that any edge effects evident in the plate were avoided in the test specimen. Each specimen was ground to a thickness of 0.375 inch by removing an equal amount of metal from the top and bottom surfaces. This insured that any surface defects developed during the loading process would be eliminated. Additional samples were removed from each plate for microhardness and microstructural analysis.

The tension test specimens were pulled on a 60,000-pound Baldwin testing machine. The pulling rate was kept constant through the yield point at 1/16 inch per minute per inch of gage length. An extensometer was used to measure the strain through the yield point; the elongation was then measured with dividers until failure occurred. Thus, it was possible to plot complete stress-strain curves for each test specimen. The yield point was determined by using the 0.2% offset method.

## EXPERIMENTAL RESULTS

### GENERAL BEHAVIOR

The general effect of a contact explosive load on each of the four steels was to permanently change the engineering properties of the metal in a characteristic manner depending on the thickness of the explosive layer and the distance from the metal-explosive interface. The types of permanent changes produced by an explosive load can be qualitatively summarized as follows: (1) substantial increase in proportional limit, (2) substantial increase in yield strength, (3) increase in ultimate strength, (4) increase in fracture strength, (5) substantial decrease in elongation to fracture, (6) decrease in elongation to ultimate strength, and (7) decrease in toughness. All of these effects became more pronounced as the thickness of the explosive layer was increased. For a given charge thickness, the closer the metal specimen was to the metal-explosive interface, the greater was the property change. In each test, as would be expected, the greatest changes occurred in the top plate, the plate in contact with the explosive. The other plates in the test, the buffered plates, showed smaller changes in properties depending on their distance from the charge.

Tables 2-5 summarize the effects that the thickness of explosive layer, and thickness of steel buffer material (or distance from metal-explosive interface) have on the proportional limit, yield strength, ultimate strength, fracture strength, percent elongation, and toughness of 1015, 1030, 1050, and 4130 steels, respectively. These tables present the experimentally determined data for each plate as well as the percent change in each property compared to the respective value for the metal in the annealed, unworked condition. It should be noted that these figures represent an average effect across the thickness of each of the specimens. In these tables the plate number designation corresponds with that shown in Fig. 1. Since toughness measures the ability of a material to absorb mechanical energy by permanent deformation in advance of fracture, and is proportional to the area under the stress-strain curve, area was taken as a relative measure of the toughness of the steels. The proportional limit values are only approximate since they depend on the sensitivity of the tensile testing machine.

#### BEHAVIOR OF CONTACT PLATES

Figures 2-5 show the effect of explosive charge size in permanently changing the properties of the contact plate (top plate) for 1015, 1030, 1050, and 4130 steels, respectively. Each of the curves represents an integrated effect over the thickness of the respective top plate. In each of these families of curves, the 0 curve represents the material in the unworked, annealed condition. The 8, 4, 2, and 1 curves represent the material after being worked with 8 layers, 4 layers, 2 layers, and 1 layer, respectively, of sheet explosive. The start of each curve represents the yield point value of the metal.

In general, the engineering properties of the contact plates of all four steels changed in a regular and predictable manner when subjected to various thicknesses of explosive. That is, the magnitude of the change in properties was related to the thickness of the explosive layer. As the thickness of the explosive charge was increased, the proportional limit, yield strength, ultimate strength, and fracture strength all increased for each of the four steels. The yield strength and the proportional limit showed the greatest susceptibility to change, the fracture strength the least. All four steels demonstrated a drastic reduction in elongation and toughness with increasing charge thickness. For example, for the 1015 steel the proportional limit values of the contact plates increased by 44, 110, 125, and 136%; the yield strengths increased by 34, 69, 82, and 125%; the ultimate strengths increased by 4, 11, 15, and 36%; and the fracture strengths increased by 2, 3, 16, and 29% for charge thicknesses of 1, 2, 4, and 8 layers, respectively. For the same plates the elongation decreased by 34, 42, 46, and 68%; and the toughness decreased by 30, 34, 35, and 58% for the different charge thicknesses in the same order. The contact plates of the other three steels showed the same general behavior patterns.

TABLE 2. Effect of Explosive Loads on the Engineering Properties of 1015 Steel

Layers of explosive	Plate no.	Proportional limit		Yield strength		Ultimate strength		Fracture strength		Elongation		Toughness	
		psi	% change	psi	% change	psi	% change	psi	% change	%	% change	%	% change
0	1	20,100	.....	33,000	.....	58,900	.....	44,600	.....	41.0	.....	.....	.....
1	1	29,000	44.3	44,300	34.2	61,500	4.4	45,300	1.6	27.0	-34.1	-30.3	-30.3
	2	23,200	15.4	37,000	12.1	59,400	0.8	45,000	0.9	39.5	-3.7	-1.7	-1.7
	3	20,200	0.5	33,000	0	58,900	0	44,600	0	41.0	0	0	0
2	1	42,200	110.0	55,900	69.4	65,300	10.9	45,700	2.5	24.0	-41.5	-34.1	-34.1
	2	36,800	83.1	48,700	47.6	64,500	9.5	45,600	2.2	28.0	-31.7	-22.3	-22.3
	3	27,400	36.3	35,000	6.1	60,700	3.1	45,500	2.0	36.0	-12.2	-9.0	-9.0
	4	(note) <sup>a</sup>	(note) <sup>a</sup>	33,000	0	58,900	0	44,600	0	41.0	0	0	0
4	1	45,300	125.5	60,000	81.8	68,000	15.4	51,500	15.5	22.0	-46.3	-35.2	-35.2
	2	38,000	89.1	53,300	61.5	64,000	8.7	49,500	11.0	27.0	-34.1	-25.9	-25.9
	3	34,200	70.1	46,000	39.4	62,600	5.6	47,100	5.6	32.0	-22.0	-14.8	-14.8
	4	31,100	54.7	37,800	14.5	61,600	4.6	47,100	5.6	35.0	-14.6	-9.3	-9.3
8	1	47,400	135.8	74,300	125.2	80,000	35.8	57,400	28.7	13.0	-68.3	-57.8	-57.8
	2	45,300	125.4	61,700	87.0	70,500	19.7	50,500	13.2	19.5	-52.4	-44.1	-44.1
	3	42,600	111.9	60,800	84.2	68,800	16.8	48,900	9.6	20.0	-51.2	-42.5	-42.5
	4	39,500	96.5	57,200	73.3	67,400	14.4	48,700	9.2	23.0	-43.9	-35.2	-35.2

<sup>a</sup> Not obtained.

TABLE 3. Effect of Explosive Loads on the Engineering Properties of 1030 Steel.

Layers of explosive	Plate no.	Proportional limit		Yield strength		Ultimate strength		Fracture strength		Elongation		Toughness	
		psi	% change	psi	% change	psi	% change	psi	% change	%	% change	%	% change
0	1	29,000	.....	34,000	.....	66,800	.....	54,000	.....	35.0	.....	.....	.....
1	1	32,900	13.4	51,600	51.8	69,300	3.7	55,000	1.9	28.0	-20.0	-14.1	-14.1
	2	29,500	1.7	40,100	17.9	68,500	2.5	56,000	3.7	32.0	-8.6	-4.7	-4.7
	3	29,000	0.0	34,000	0	66,800	0	54,000	0	35.0	0	0	0
2	1	43,400	49.7	56,600	66.5	70,800	6.0	55,000	1.9	26.0	-25.7	-18.8	-18.8
	2	39,500	36.2	53,700	57.9	69,800	4.5	59,100	9.4	26.5	-24.3	-16.5	-16.5
	3	35,500	22.4	41,400	21.8	69,600	4.2	57,400	6.3	31.5	-10.0	-4.7	-4.7
	4	29,200	0.7	37,900	11.5	67,000	0.3	54,000	0	33.0	-5.7	-3.5	-3.5
4	1	48,700	67.9	62,100	82.6	71,000	6.3	59,800	10.7	23.0	-34.3	-25.2	-25.2
	2	32,900	13.4	54,900	61.5	71,500	7.0	58,300	8.0	28.0	-20.0	-12.9	-12.9
	3	31,700	9.3	52,200	53.5	70,600	5.7	57,700	6.9	28.5	-18.6	-9.4	-9.4
	4	31,700	9.3	52,300	53.8	70,000	4.8	57,500	6.5	29.0	-17.1	-9.4	-9.4
8	1	57,900	99.7	73,500	116.2	77,500	16.0	63,000	16.7	17.0	-51.4	-41.2	-41.2
	2	50,000	72.4	71,500	110.3	75,000	12.3	57,500	6.5	18.0	-48.6	-40.5	-40.5
	3	47,300	63.1	62,200	82.9	75,500	13.0	61,000	13.0	20.0	-42.9	-31.8	-31.8
	4	43,400	49.7	57,800	70.0	71,500	7.0	56,600	4.8	24.5	-30.0	-22.8	-22.8

TABLE 4. Effect of Explosive Loads on the Engineering Properties of 1050 Steel

Layers of explosive	Plate no.	Proportional limit		Yield strength		Ultimate strength		Fracture strength		Elongation		Toughness	
		psi	% change	psi	% change	psi	% change	psi	% change	%	% change	%	% change
0	1	31,600	.....	49,800	.....	90,700	.....	77,000	.....	27.5	.....	.....	.....
1	1	44,700	41.4	66,000	32.5	90,300	-0.4	77,600	0.8	26.5	-3.6	-1.1	-1.1
	2	39,400	24.7	55,000	10.4	92,600	2.1	87,400	13.5	20.0	-27.3	-26.1	-26.1
	3	31,600	0.0	49,800	0	90,700	0	77,000	0	27.5	0	0	0
2	1	50,000	58.2	74,500	50.0	95,000	4.7	87,700	13.9	21.0	-23.6	-16.3	-16.3
	2	47,400	50.0	62,300	25.1	94,200	3.9	84,100	9.2	22.0	-20.6	-15.2	-15.2
	3	42,200	33.5	55,500	11.4	92,000	1.4	80,000	3.9	25.0	-9.1	-4.3	-4.3
	4	31,600	0.0	49,800	0	90,700	0	77,000	0	27.0	0	0	0
4	1	55,300	75.0	79,900	60.4	97,200	7.2	87,600	13.8	20.0	-27.3	-18.5	-18.5
	2	48,000	51.9	70,800	42.2	90,600	-0.1	78,100	1.4	25.5	-7.3	-3.3	-3.3
	3	45,000	42.4	61,800	24.1	90,500	-0.2	77,200	0.3	26.5	-3.6	0	0
	4 <sup>a</sup>	.....	.....	.....	.....	.....	.....	.....	.....	.....	.....	.....	.....
8	1	58,000	83.5	84,300	69.3	98,100	8.2	89,200	15.8	20.0	-27.3	-17.4	-17.4
	2	52,600	66.4	81,000	62.7	93,800	3.4	79,500	3.2	23.0	-16.4	-9.8	-9.8
	3	50,000	58.2	72,200	45.0	93,800	3.4	83,700	8.7	21.0	-23.6	-17.4	-17.4
	4	47,400	50.0	67,300	35.1	93,400	3.0	87,000	13.0	19.0	-30.9	-26.1	-26.1

<sup>a</sup> Disregarded due to incipient fractures.

TABLE 5. Effect of Explosive Loads on the Engineering Properties of 4130 Steel.

Layers of explosive	Plate no.	Proportional limit		Yield strength		Ultimate strength		Fracture strength		Elongation		Toughness	
		psi	% change	psi	% change	psi	% change	psi	% change	%	% change	%	% change
0	1	20,200	.....	39,000	.....	77,600	.....	57,800	.....	35.0	.....	.....	.....
1	1	27,000	33.7	48,000	23.1	79,200	2.1	59,600	3.1	33.0	-5.7	-3.0	-3.0
	2	21,200	5.0	43,200	10.8	79,500	2.4	58,500	1.2	33.5	-4.3	0	0
	3	20,200	0.0	39,000	0	77,600	0	57,800	0	35.0	0	0	0
2	1	42,700	111.4	65,800	68.7	79,300	2.2	60,300	4.3	31.0	-11.4	-6.1	-6.1
	2	29,000	43.6	57,000	46.2	78,600	1.3	59,400	2.8	37.0	-8.6	-5.1	-5.1
	3	22,900	13.4	47,100	20.8	77,800	0.3	58,600	1.4	33.0	-5.7	-4.0	-4.0
	4	20,200	0.0	39,000	0	77,600	0	57,800	0	35.0	0	0	0
4	1	47,400	134.7	75,500	93.6	80,600	3.9	60,900	5.4	26.5	-24.5	-18.2	-18.2
	2	39,500	95.5	72,900	86.9	80,500	3.7	57,000	-1.4	28.5	-18.6	-13.1	-13.1
	3	31,600	56.4	60,700	55.6	79,800	2.8	58,600	1.4	31.0	-11.4	-7.1	-7.1
	4	29,000	43.6	58,600	50.3	79,400	2.3	58,200	0.7	32.0	-8.6	-5.1	-5.1
8	1	50,500	150.0	84,400	116.4	86,600	11.6	62,500	8.1	17.0	-51.4	-46.5	-46.5
	2	42,200	108.9	72,900	86.9	81,600	5.2	59,000	2.1	27.0	-22.9	-15.2	-15.2
	3	39,500	95.5	71,100	82.3	81,000	4.4	57,400	-0.7	29.0	-17.1	-10.1	-10.1
	4	31,600	56.4	70,500	80.8	80,900	4.3	55,900	-3.3	29.0	-17.1	-10.1	-10.1

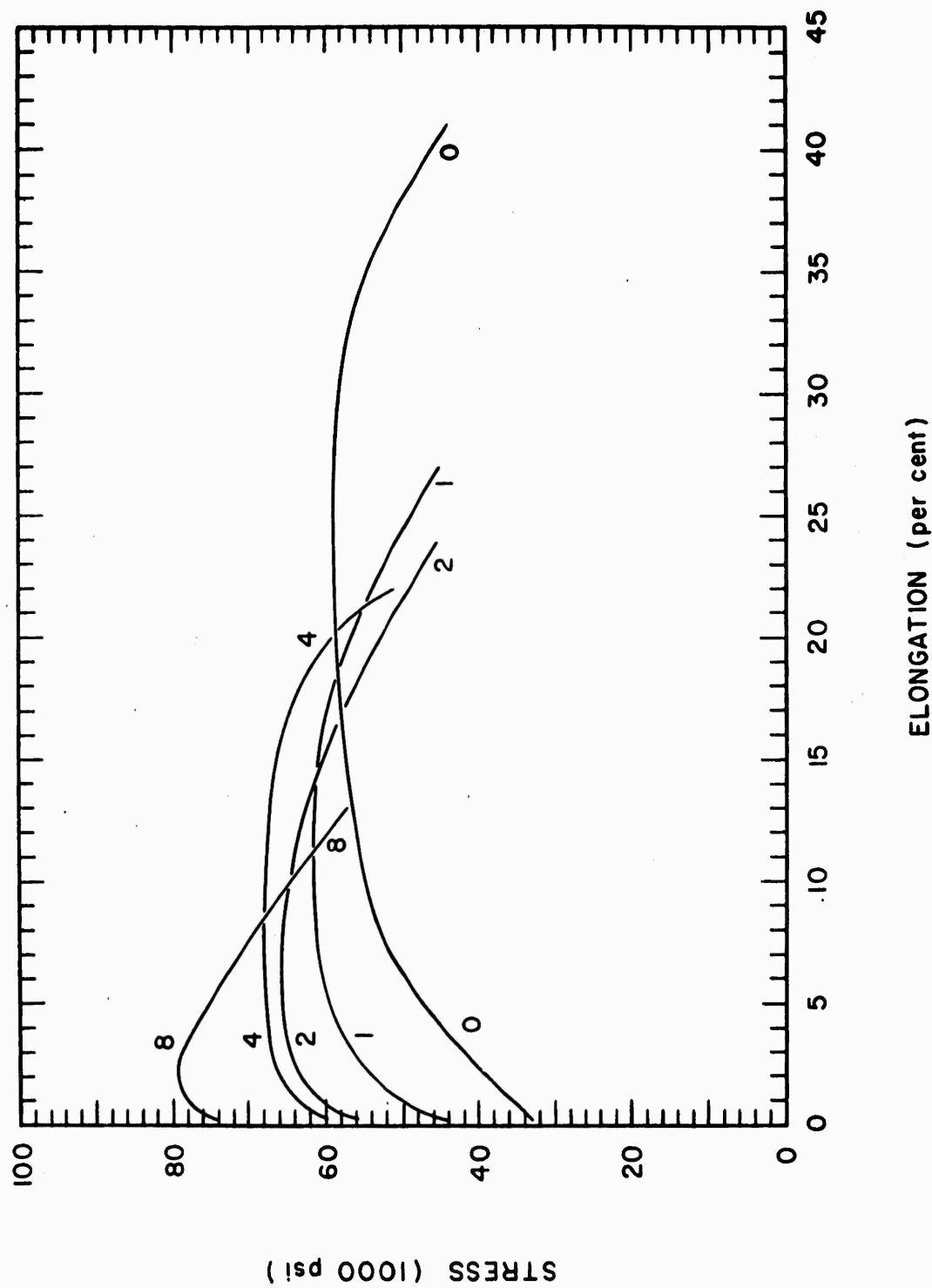

FIG. 2. Stress-Strain Curves for Contact Plates of 1015 Steel Loaded With Different Thicknesses of Explosive.

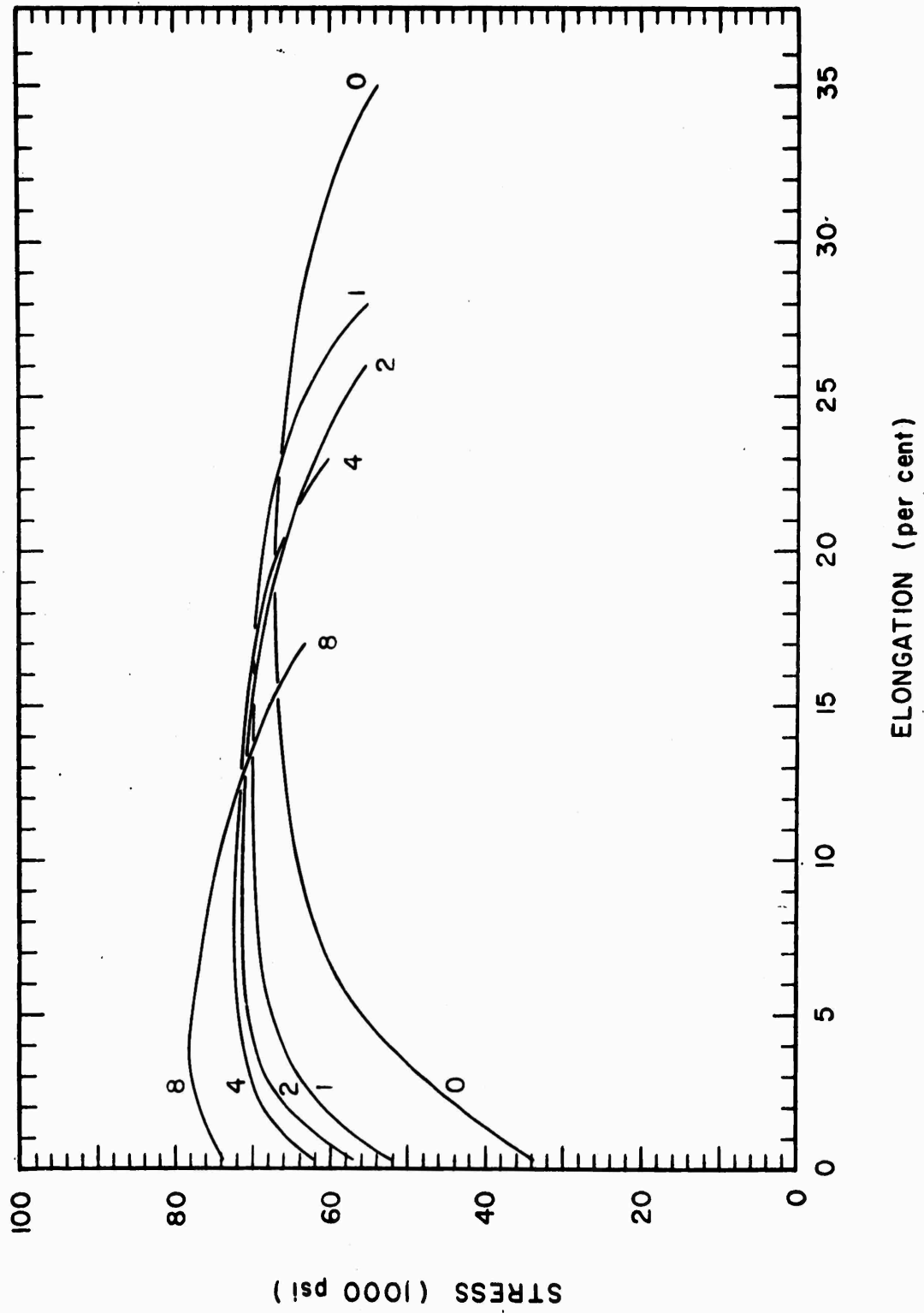

FIG. 3. Stress-Strain Curves for Contact Plates of 1030 Steel Loaded With Different Thicknesses of Explosive.

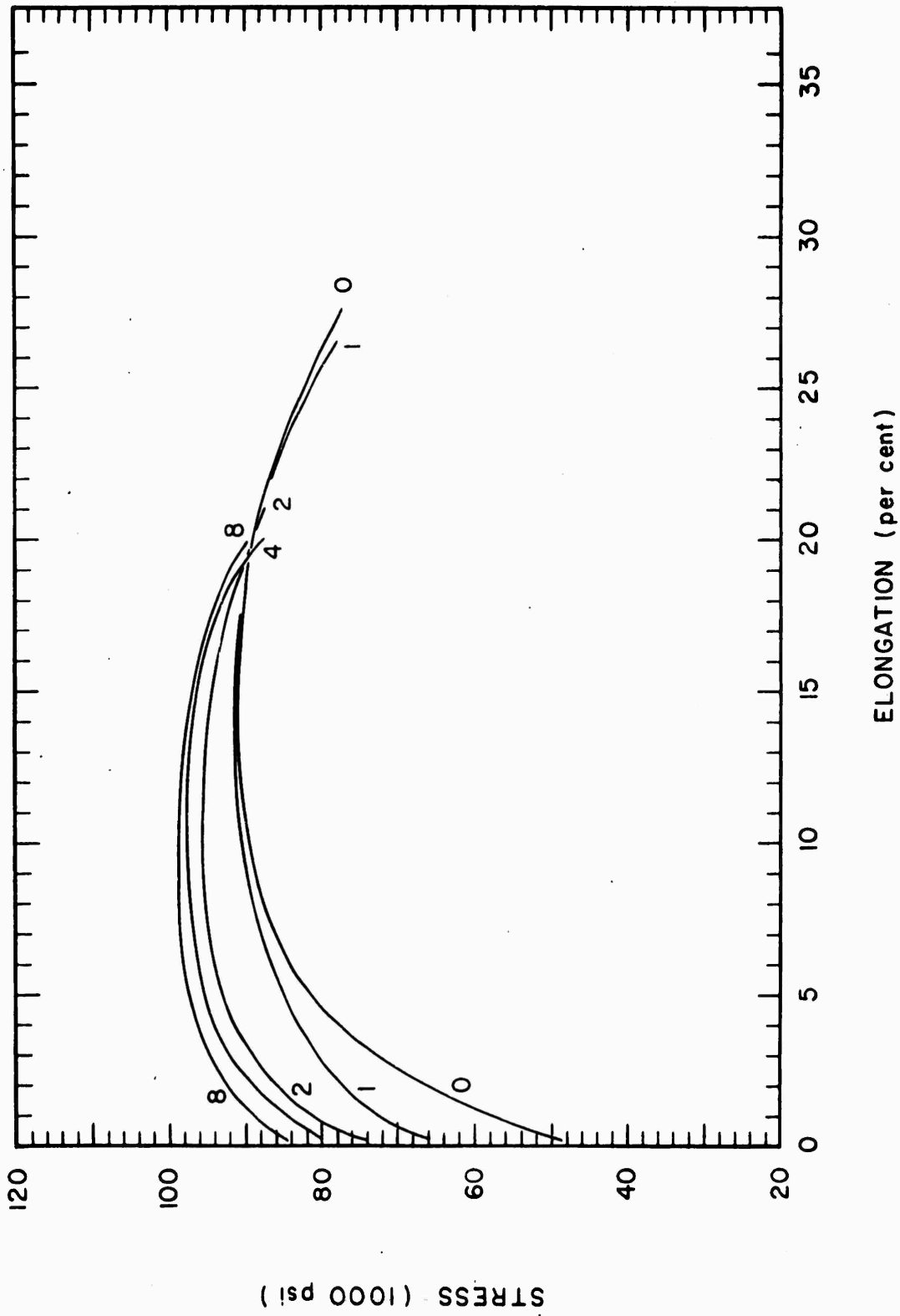

FIG. 4. Stress-Strain Curves for Contact Plates of 1050 Steel Loaded With Different Thicknesses of Explosive.

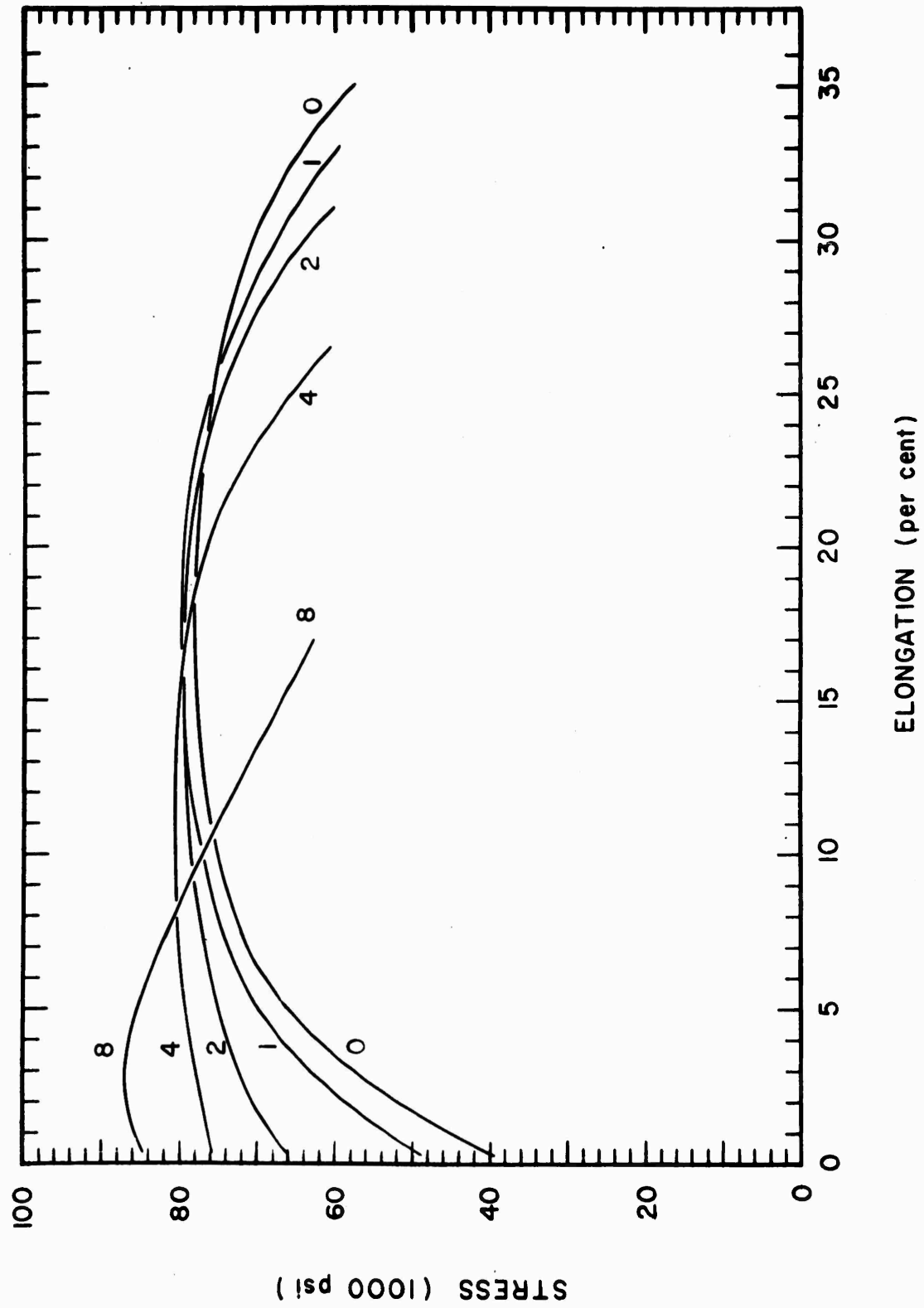

FIG. 5. Stress-Strain Curves for Contact Plates of 4130 Steel Loaded With Different Thicknesses of Explosive.

Such data indicate how marked differences can occur in the properties of various metals when subjected to contact charges of different sizes. Of the four steels studied, the contact plates of the 1015 steel showed the greatest over-all changes in the strength and ductility characteristics.

On a comparison basis, with a given charge thickness, the four steels demonstrated somewhat different susceptibilities to change in their various properties. For example, with 8-layer charges the proportional limits of the contact plates increased by 136, 100, 84, and 150%; the yield strengths increased by 125, 116, 69, and 116%; the ultimate strengths increased by 29, 17, 16, and 8% for 1015, 1030, 1050, and 4130 steels, respectively. Similarly, for the same charge thickness the elongation decreased by 68, 51, 27, and 51%; and the toughness decreased by 58, 41, 17, and 46% for the four steels in the same respective order as above.

It was found that while the yield strengths of the contact plates were greatly increased, the plates underwent only a relatively small decrease in thickness. If conventional loading techniques had been employed to obtain the same change in yield strength that was produced by the explosive load, a much greater percent reduction in thickness would have resulted. This is shown in Table 6 that compares the percent reduction of thickness of steels explosively and conventionally worked for the same increase in yield strength. The increase in yield strength by explosive working values used in Table 6 are those obtained by work hardening with 8 layers of explosive.

TABLE 6. Reduction in Thickness of Steel Plates Under Explosive and Conventional Loads

Type of steel	Change in yield stress <sup>a</sup>		Reduction in thickness, %	
	psi	%	Explosive load	Conventional load <sup>b</sup>
1015	41,300	125	5	70
1030	39,500	116	4	>50
1050	34,500	69	3	>40
4130	45,400	116	3	....

<sup>a</sup> Resulting from eight layers of explosive.  
<sup>b</sup> References 3 and 4.

## BEHAVIOR OF PLATE SYSTEMS

The curves of Fig. 6-21 show the manner in which the properties of explosively loaded materials can vary as a function of distance from the metal-explosive interface for contact charges of different thickness. In addition to indicating how the properties of an explosively worked body can vary from point to point within that body, the curves also show the effect of buffering the load. That is, in these tests each plate served as a buffer to reduce the amount of working that the adjacent plate beneath it received.

The behavior of each steel is represented by four sets of curves, each set showing the behavior of a plate system for a given charge thickness. For example, Fig. 6-9 show the stress-strain data for each plate for four separate tests conducted on 1015 steel in which the explosive charges consisted of 1, 2, 4, and 8 layers of sheet explosive, respectively. In each figure the 0 curve represents the 1015 steel in the annealed condition. The designations 1st, 2nd, 3rd, and 4th represent the locations of the plates and are the same as given in Fig. 1. Figures 10-13, 14-17, and 18-21 give corresponding data for 1030, 1050, and 4130 steels, respectively.

For a given charge size, an increase in distance from the metal-explosive interface reduces the effect that the load has on changing the properties of the metal. For example, for a 2-layer charge on a family of four 1050 steel plates the proportional limit increased 58, 50, 34, and 0%; the yield strength increased 50, 25, 11, and 0%; the ultimate strength increased 4.7, 3.9, 1.4, and 0%; and the fracture strength increased 14, 9, 4, and 0% for the first, second, third, and fourth plates, respectively. For the same plate sequence the elongation decreased 24, 21, 9, and 0%; and the toughness decreased 16, 15, 4, and 0%. These data are particularly interesting since they show that a wide range of property values extending from no change to an extremely large change can occur in different areas of a metal specimen separated by a distance of only 1 or 2 inches.

An increase in the thickness of the explosive layer not only increased the magnitude of the property changes in the steels, but also increased the depth to which property changes occurred. With a 1-layer charge of explosive only the first two plates showed any change in engineering properties. This was the case for all four of the steels. With a 2-layer charge the 1015, 1050, and 4130 steels showed property changes in the first three plates, but not in the fourth, while the 1030 steel also showed some changes in the fourth plate. With 3- and 4-layer charges, property changes occurred in all four plates for all the steels tested.

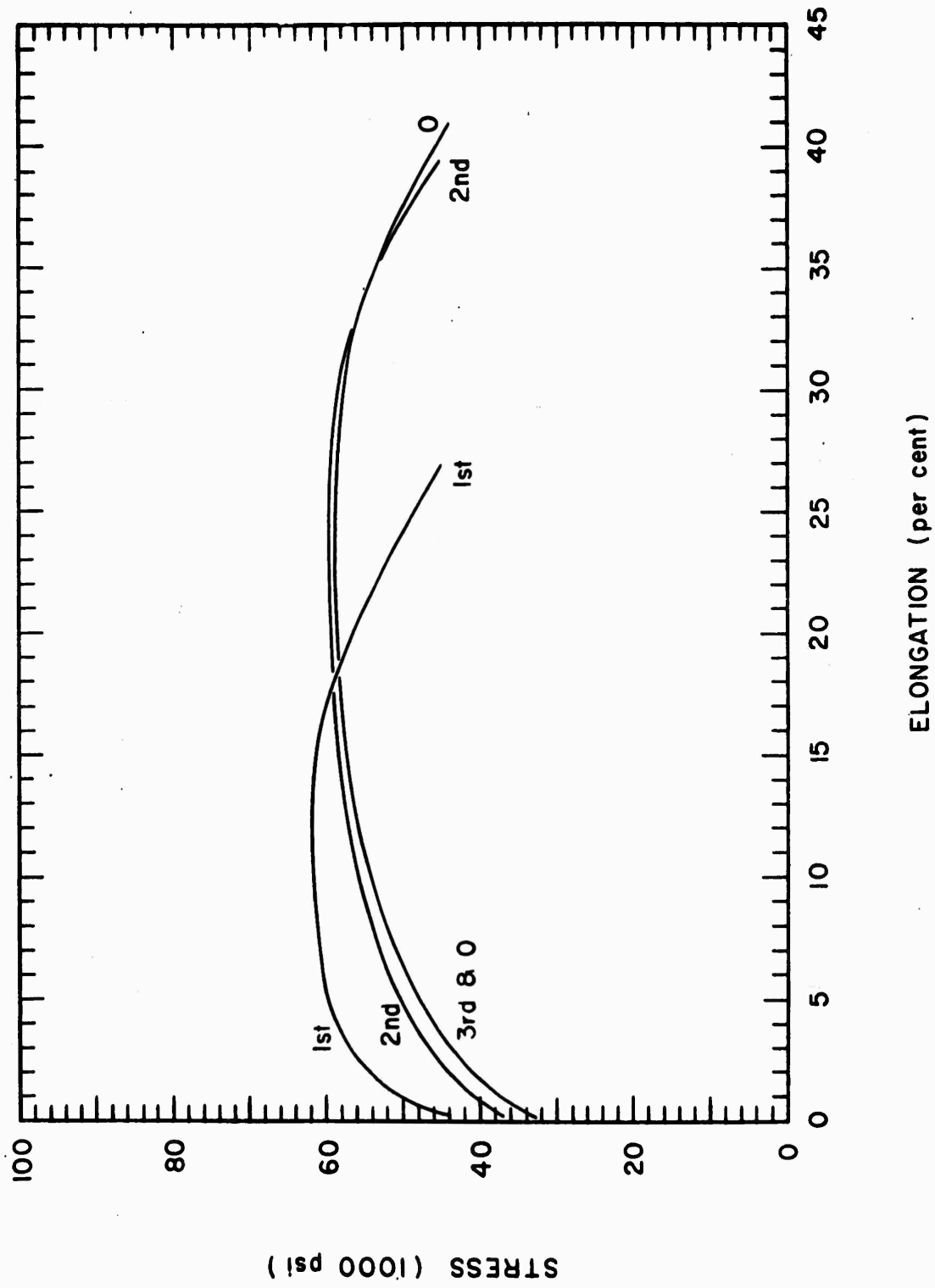

FIG. 6. Stress-Strain Curves for 1015 Steel Plates Loaded With One Layer of Explosive.

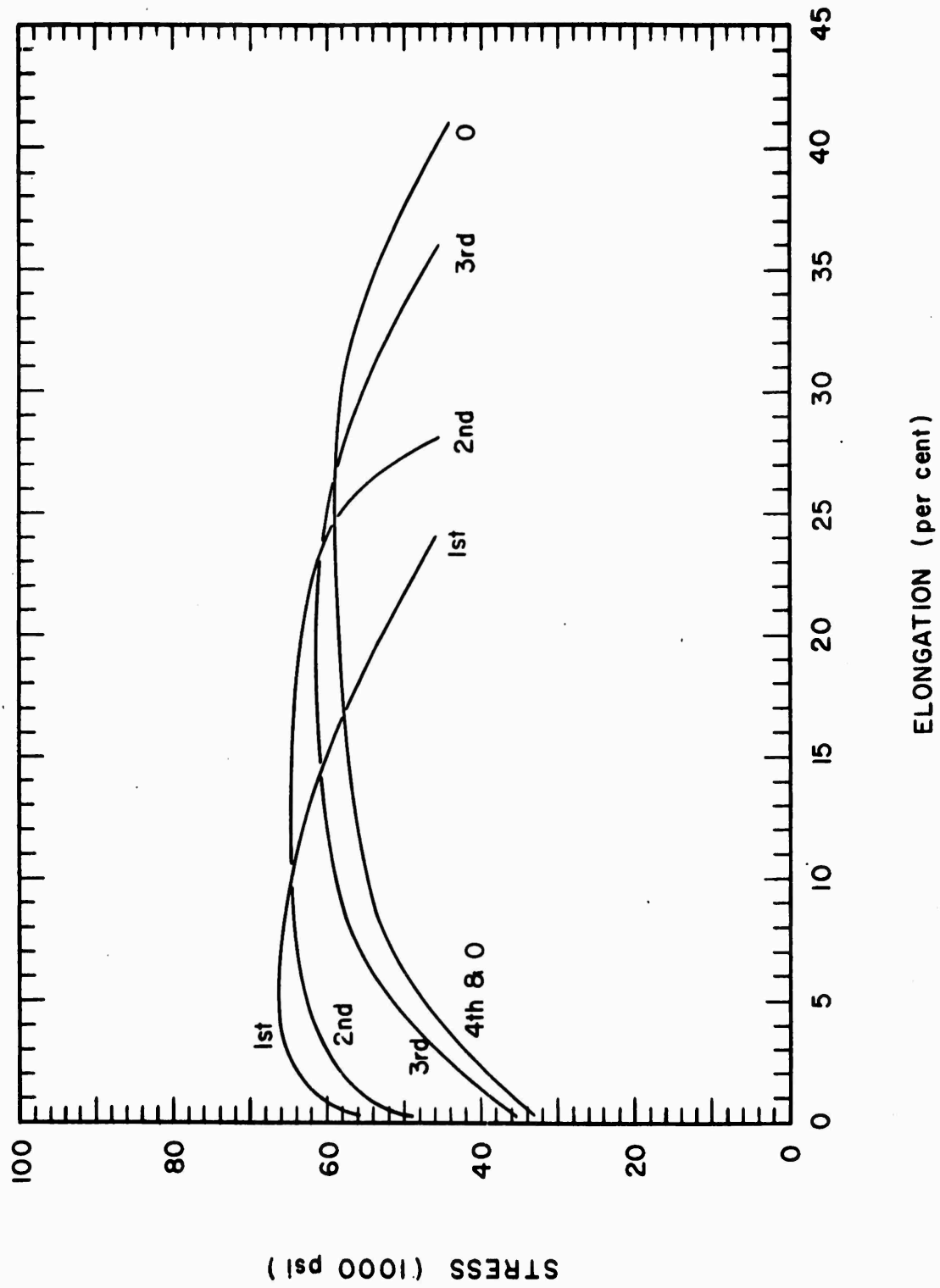

FIG. 7. Stress-Strain Curves for 1015 Steel Plates Loaded With Two Layers of Explosive.

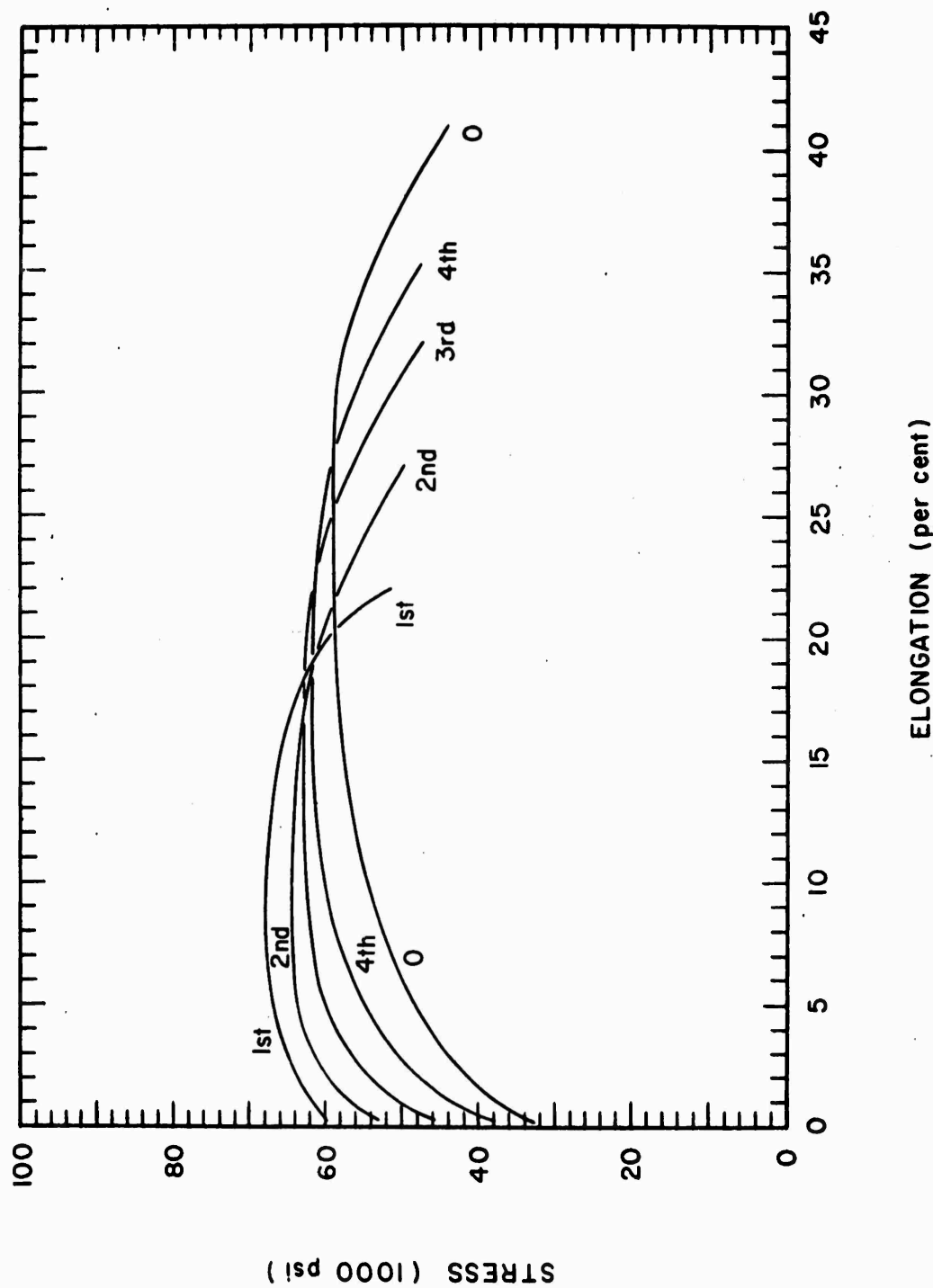
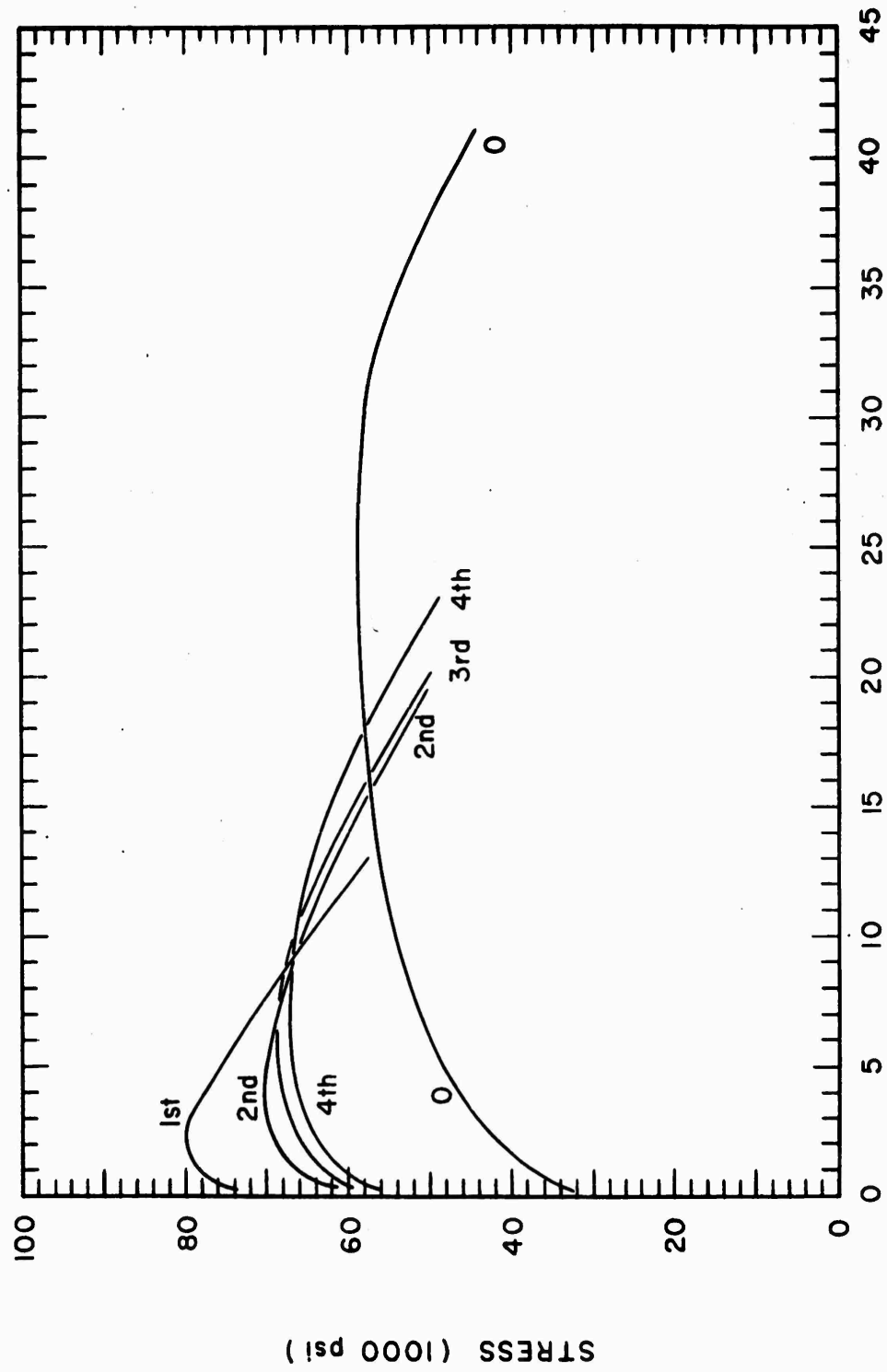

FIG. 8. Stress-Strain Curves for 1015 Steel Plates Loaded With Four Layers of Explosive.



ELONGATION (per cent)

FIG. 9. Stress-Strain Curves for 1015 Steel Plates Loaded With Eight Layers of Explosive.

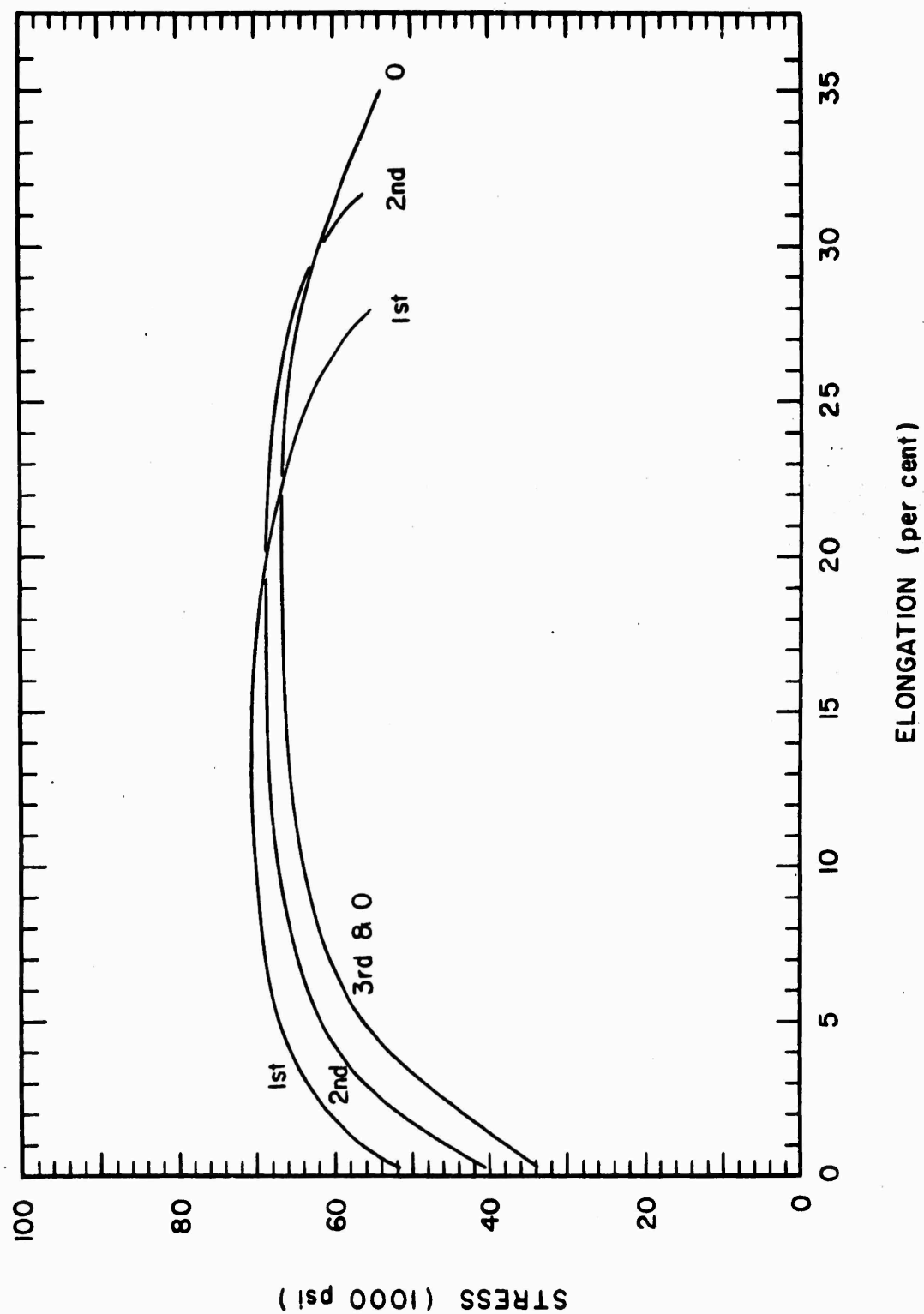

FIG. 10. Stress-Strain Curves for 1030 Steel Plates Loaded With One Layer of Explosive.

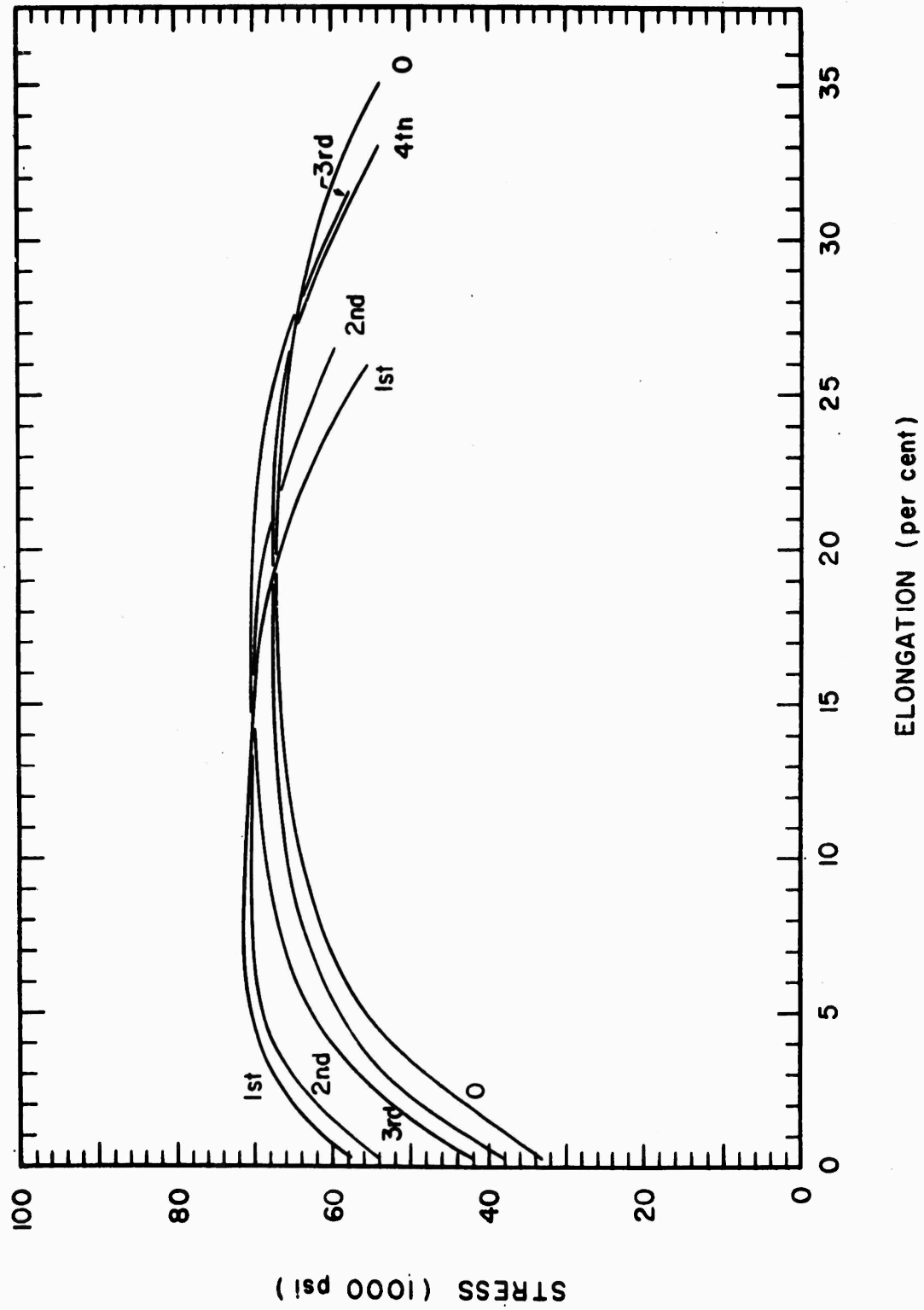

FIG. 11. Stress-Strain Curves for 1030 Steel Plates Loaded With Two Layers of Explosive.

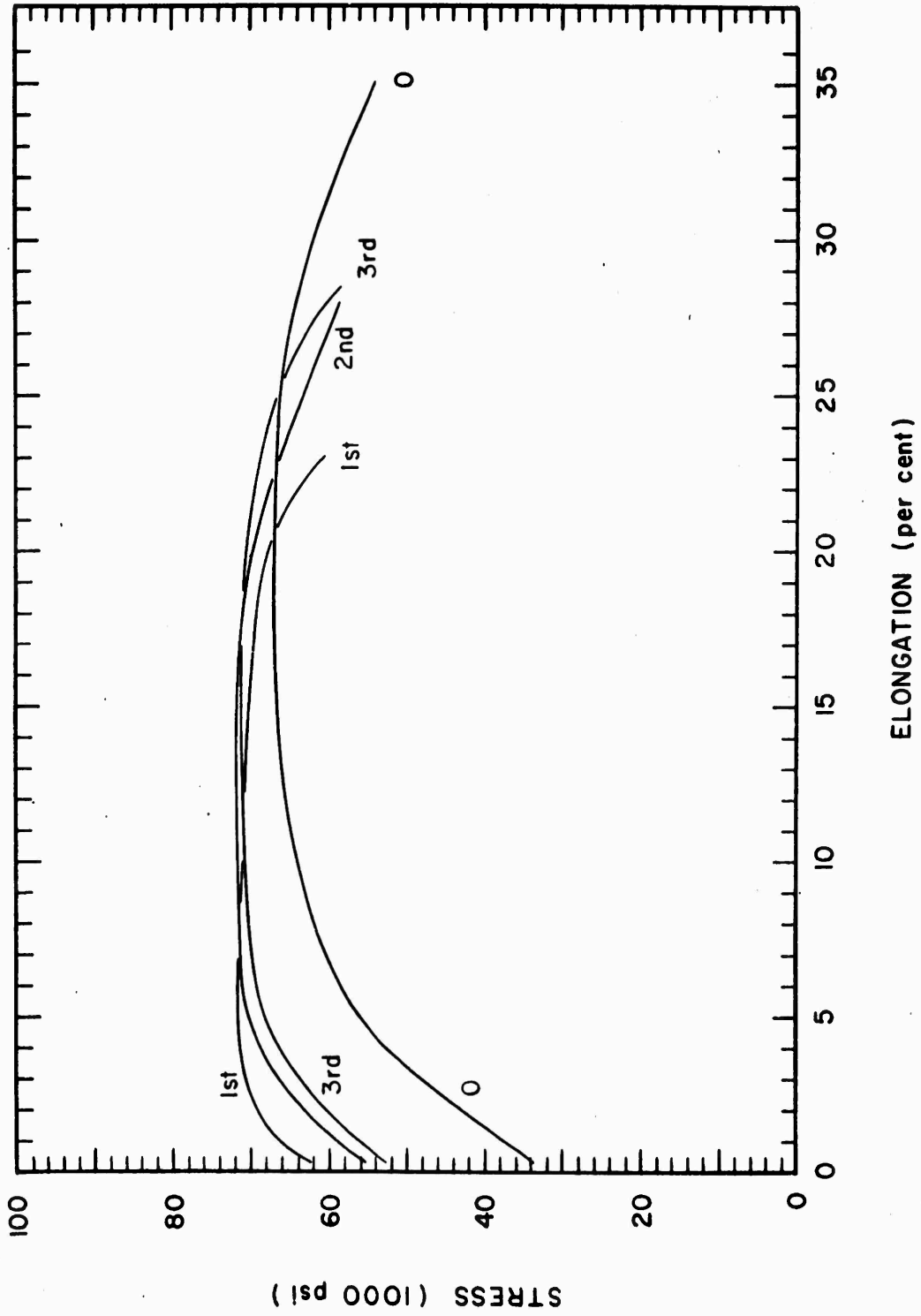

FIG. 12. Stress-Strain Curves for 1030 Steel Plates Loaded With Four Layers of Explosive.

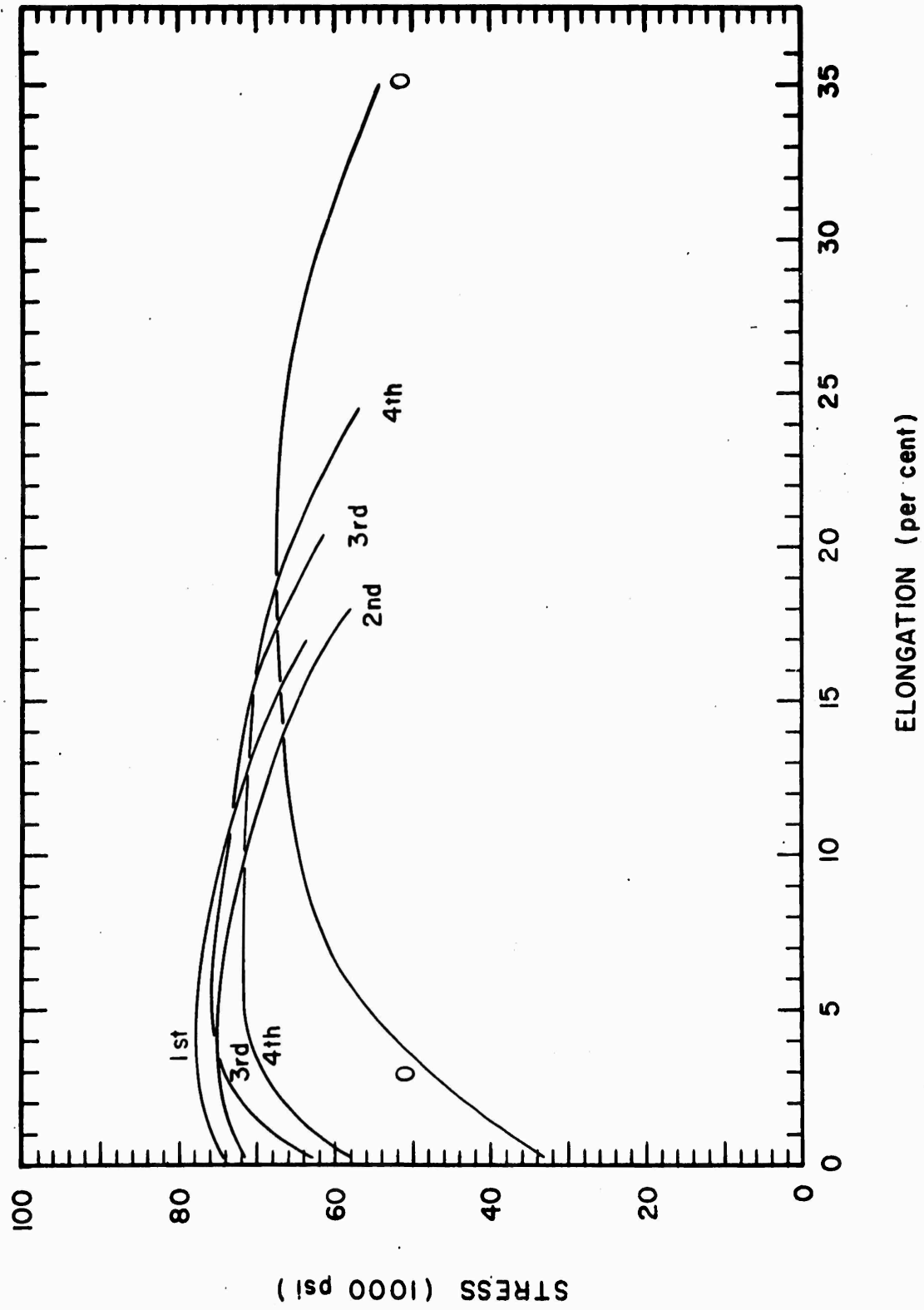

FIG. 13. Stress-Strain Curves for 1030 Steel Plates Loaded With Eight Layers of Explosive.

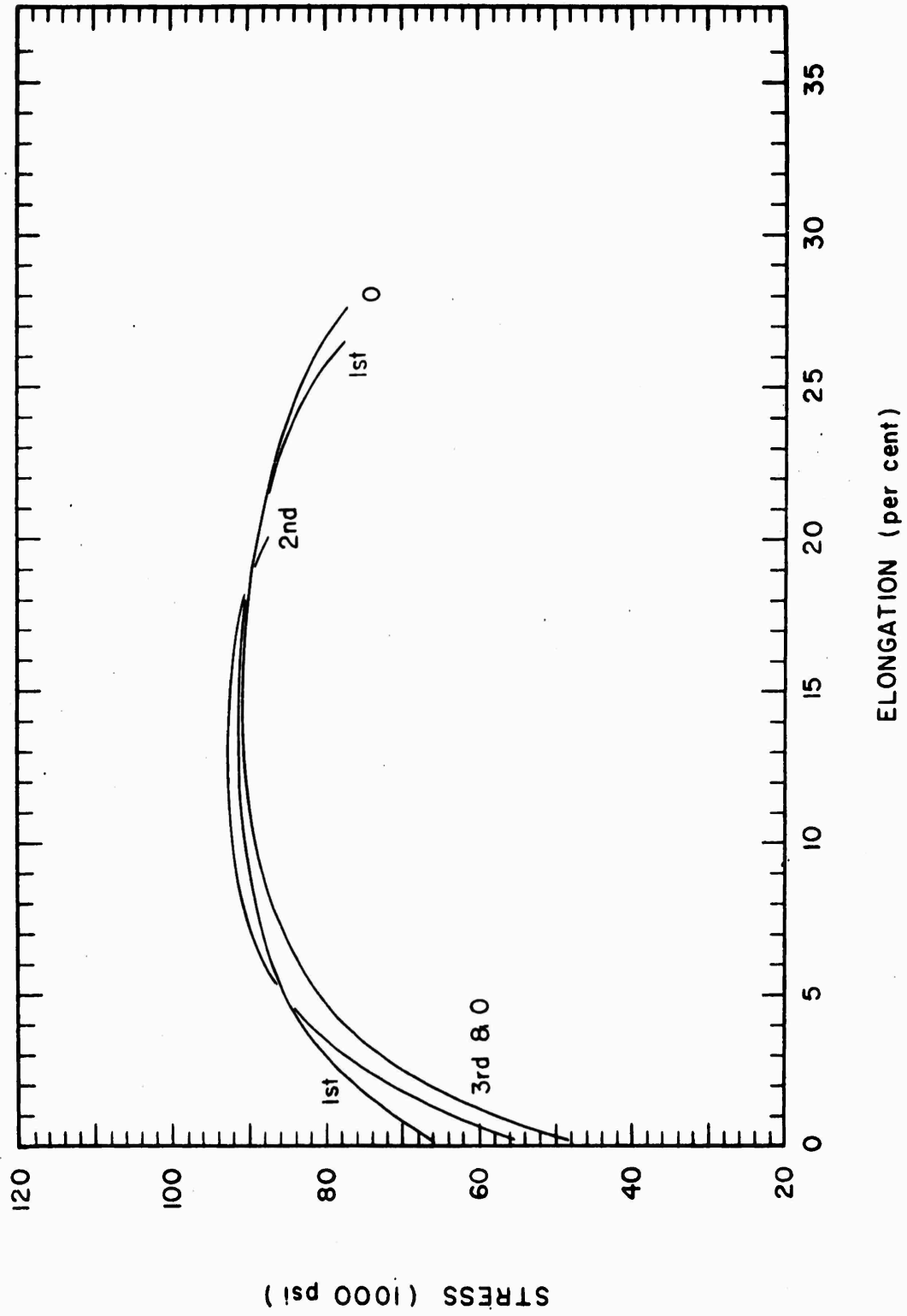

FIG. 14. Stress-Strain Curves for 1050 Steel Plates Loaded With One Layer of Explosive.

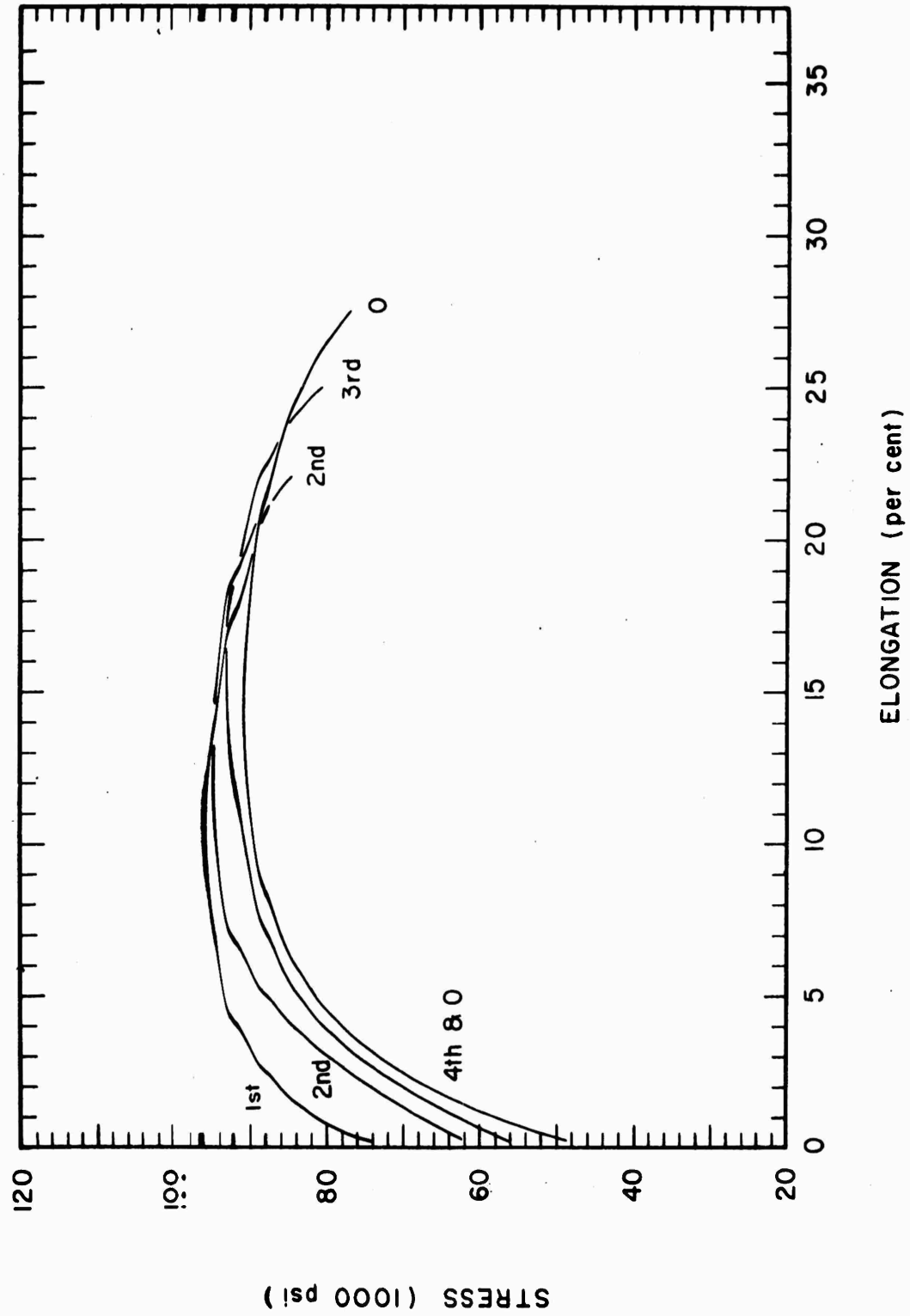

FIG. 15. Stress-Strain Curves for 1050 Steel Plates Loaded With Two Layers of Explosive.

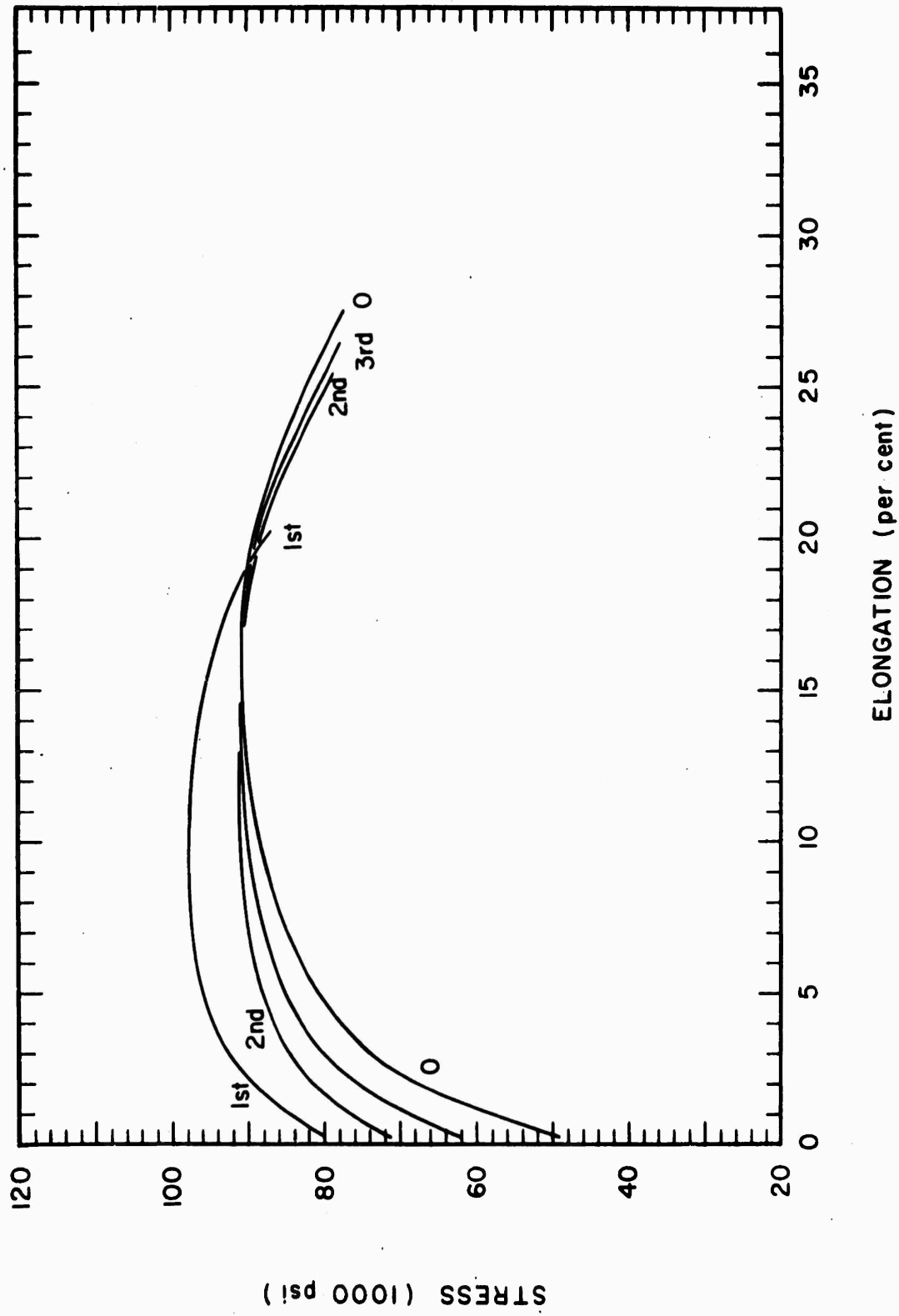

FIG. 16. Stress-Strain Curves for 1050 Steel Plates Loaded With Four Layers of Explosive.

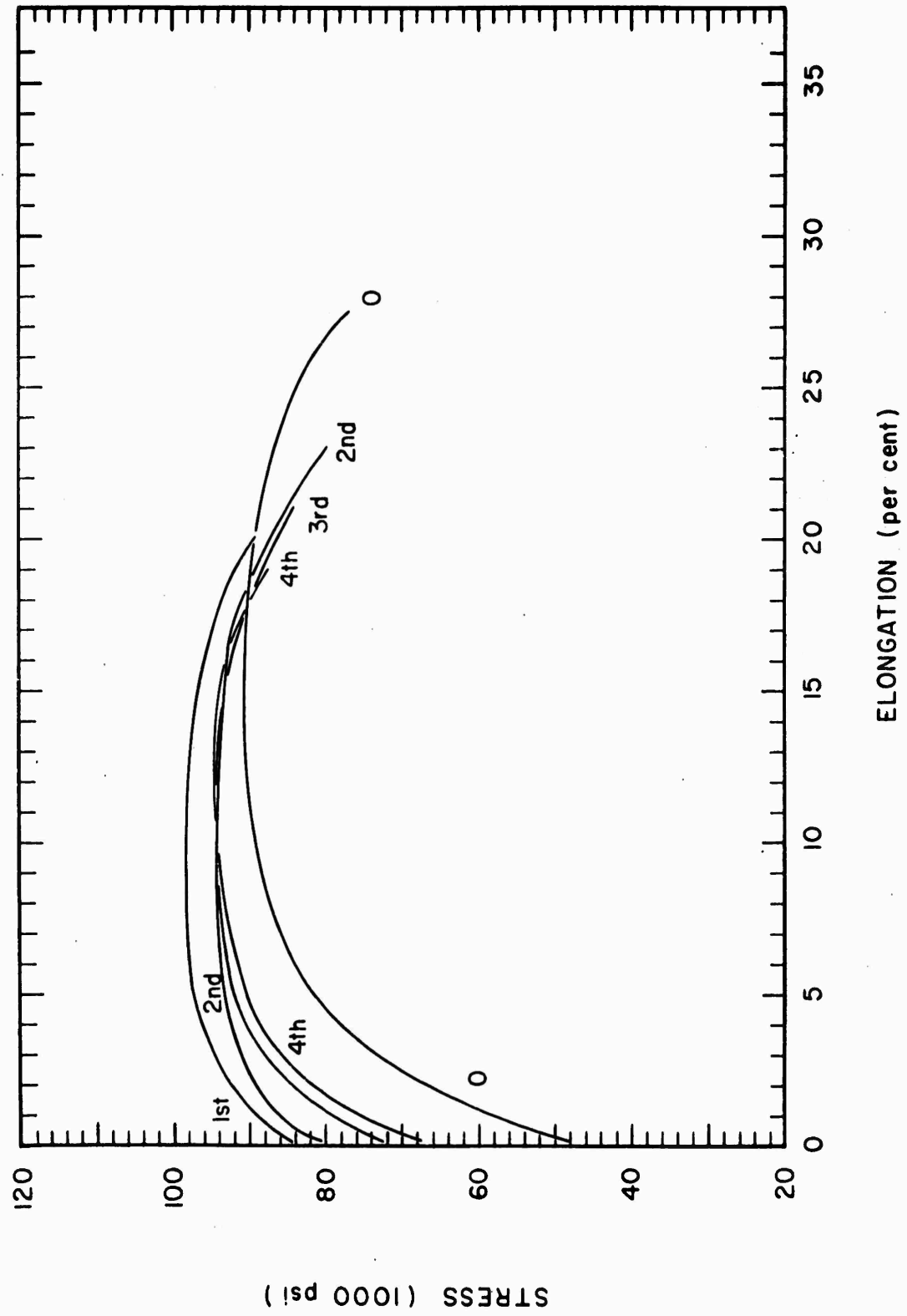

FIG. 17. Stress-Strain Curves for 1050 Steel Plates Loaded With Eight Layers of Explosive.

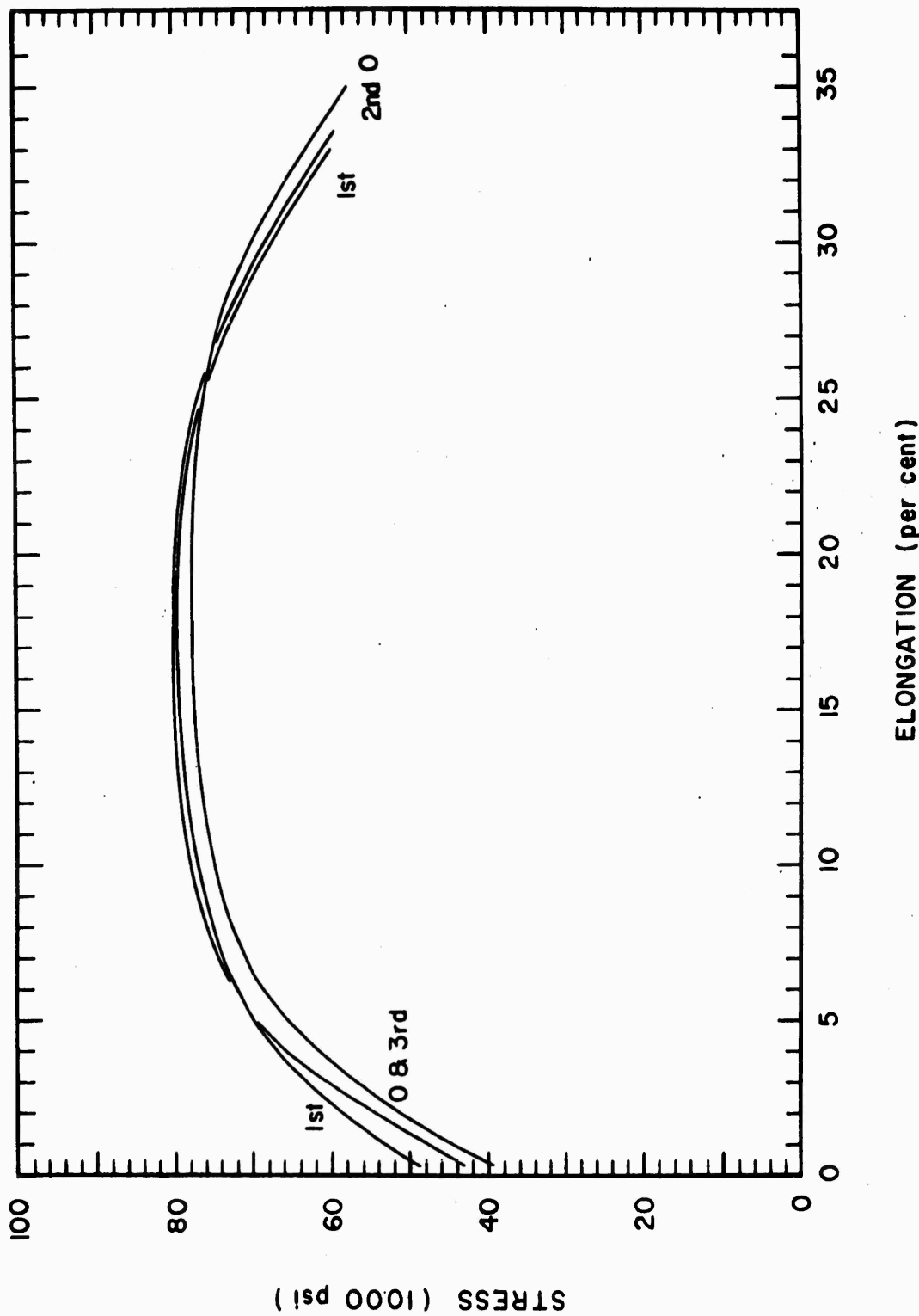

FIG. 18. Stress-Strain Curves for 4130 Steel Plates Loaded With One Layer of Explosive.

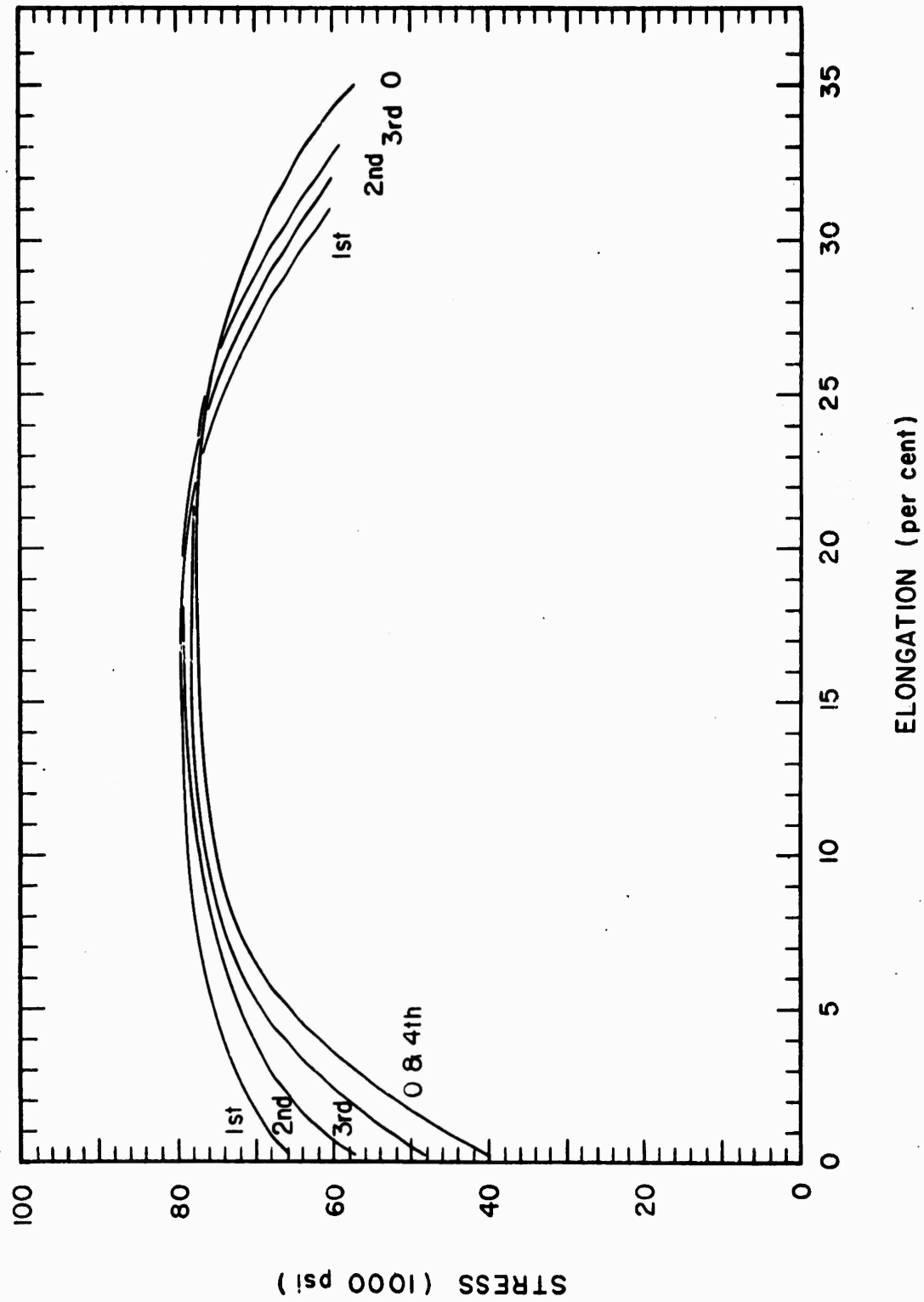

FIG. 19. Stress-Strain Curves for 4130 Steel Plates Loaded With Two Layers of Explosive.

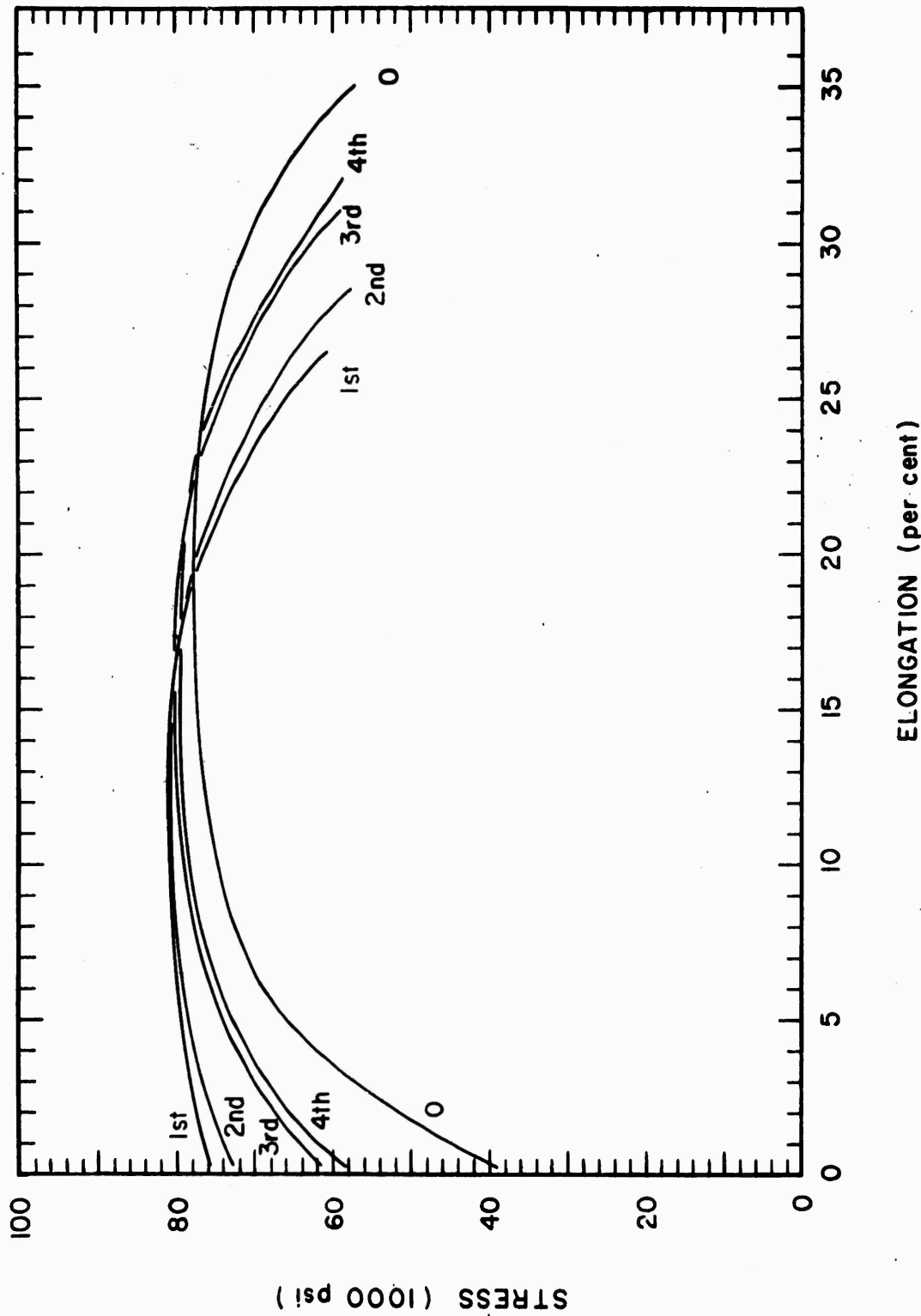

FIG. 20. Stress-Strain Curves for 4130 Steel Plates Loaded With Four Layers of Explosive.

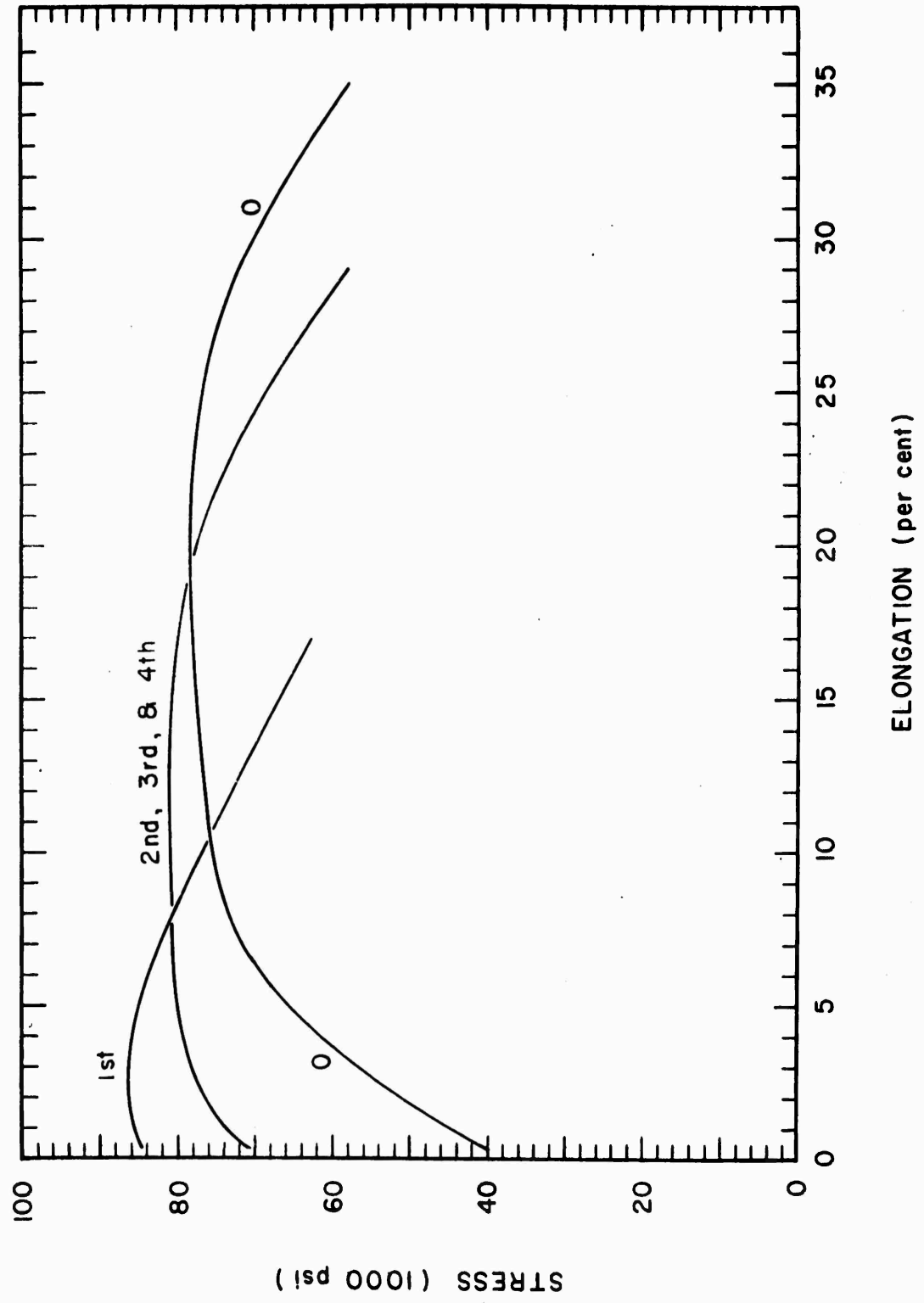

FIG. 21. Stress-Strain Curves for 4130 Steel Plates Loaded With Eight Layers of Explosive.

## OTHER CONSIDERATIONS

## TYPE OF LOAD

In any comparison of the present test data with respect to property changes in other explosively loaded metal systems, two factors should be considered. One is the geometry of the load, the other is the physical nature of the workpiece (i.e., stacked plates, single body, etc.). All other conditions being equal, variations in either of these factors would tend to change the resulting engineering properties of the worked metal. These factors can be briefly considered in terms of the present load geometry and an extreme variation to this geometry where the detonation front impinged normal to the metal surface.

In the current studies the detonation front swept across the top plate parallel to the upper surface. Large differences in both the peak pressure at the interface, and in the pressure-time distribution on the upper surface would be experienced, for example, if the detonation front impinged normally against the upper surface of the top plate, as would be the case if a plane wave generator were used to load the plates (Ref. 1 and 2).

Within the metal, differences in load geometry effect the shape of the induced stress pulse. When a plane wave generator is used, for example, a relatively plane fronted stress wave propagates through the metal with the front surface of the wave remaining essentially parallel to the loaded surface. In the present studies, where the detonation front sweeps across the surface of the metal, the longitudinal stress wave induced in the stacked plates will propagate through the metal with a front inclined to the surface of the metal-explosive interface. This angle is determined by the detonation velocity of the sheet explosive, and the stress wave velocity of the steel (Ref. 2). Such differences in the shape and propagation direction of the stress pulse in different systems can effect the resulting engineering properties of the worked metal.

The orientation of the stress wave is also connected with the second factor, the physical nature of the workpiece. A stress wave impinging at oblique incidence against a steel-steel interface would tend to lose energy in the transmittal of the pulse across the interface. The problem of transmitting stress energy across an interface would be reduced for the case of normal incidence, and would not exist if a single metal body were used. In the present studies it is believed that this problem was minimized by the care taken in the preparation and stacking of the plates. However, it could not be completely eliminated.

## MATERIAL CONSIDERATIONS

After reviewing the results of this investigation it can be seen that in general, the metals examined behaved in a regular and predictable manner with respect to changes in the engineering properties as a function of explosive thickness and distance from the metal-explosive interface. However, a few inconsistencies were observed for the 1050 steel.

Table 4 summarizes the effects that explosive working had on the annealed 1050 steel. It can be seen that for several of the tests the strength values, percent elongations, and toughness did not vary in as predictable a manner as for the other steels. A detailed microstructural analysis indicated that severe fibering and slag stringers were present in the 1050-steel specimens, while the other steels were free from these effects. These effects tended to cause incipient fractures to form during the loading process. Most of these cracks were microscopic in size and not noticed until after the tension tests were completed. In one case, however, Test No. 4 in Table 4, the cracks in the fourth plate were macroscopic in size and the plate was discarded from the study.

---

## REFERENCES

1. Duvall, George E. "Some Properties and Applications of Shock Waves," in Response of Metals to High Velocity Deformation, ed. by P. G. Shewmon and V. F. Zackay. New York, Interscience, 1960. Vol. 9, pp. 165-202.
2. Rinehart, J. S., and J. Pearson. Behavior of Metals Under Impulsive Loads. Cleveland, American Society for Metals, 1954.
3. Metals Handbook, Properties and Selection of Metals, 8th ed. Novelty, Ohio, American Society for Metals, Vol. 1, 1961, pp. 71-78, 544.
4. Watertown Arsenal Laboratory, Significant Properties and Characteristics of Cold Worked Steels, by L. J. Ebert, of Case Institute of Technology, Cleveland, Ohio, prepared under Contract DA-33-019-ORD-1464. Watertown, Mass., WAL, June 1955. (WAL Report No. 310/90-85.)

INITIAL DISTRIBUTION

- 25 Chief, Bureau of Naval Weapons
- |              |             |
|--------------|-------------|
| DLI-31 (2)   | RRRE (1)    |
| RAAV (1)     | RRRE-5 (1)  |
| RAAV-34 (1)  | RSSH-32 (1) |
| RM-3 (1)     | RU (1)      |
| RMMO-4 (2)   | RUME-11 (1) |
| RMMO-5 (1)   | RUME-3 (2)  |
| RMMO-512 (1) | RUME-32 (4) |
| RMMO-522 (1) | RUTO-2 (1)  |
| RR (1)       |             |
| RRMA (2)     |             |
- 5 Chief of Naval Operations
- Deputy Chief for Air (1)
  - Operations Evaluation Group (2)
  - OP-55 (1)
  - OP-721D (1)
- 3 Chief of Naval Research
- Code 104 (1)
  - Code 429 (1)
  - Code 461 (1)
- 1 Air Development Squadron 5, Naval Air Facility, China Lake
- 1 David W. Taylor Model Basin
- 1 Fleet Anti-Air Warfare Training Center, San Diego
- 1 Naval Air Force, Atlantic Fleet
- 2 Naval Air Force, Pacific Fleet
- 1 Naval Air Material Center, Philadelphia
- 2 Naval Air Mobile Training, Naval Air Station, Miramar
- Naval Air Mobile Training Detachment, 4003 Ordnance (1)
  - Naval Air Mobile Training Detachment, 4030 Missile (1)
- 1 Naval Air Station, North Island
- 2 Naval Air Test Center, Patuxent River (Aeronautical Publications Library)
- 1 Naval Avionics Facility, Indianapolis (Library)
- 1 Naval Explosive Ordnance Disposal Technical Center, Naval Propellant Plant, Indian Head
- 1 Naval Missile Center, Point Mugu (Technical Library)
- 1 Naval Ordnance Laboratory, White Oak (Guided Missile Warhead Section)
- 1 Naval Postgraduate School, Monterey
- 2 Naval Propellant Plant, Indian Head (Research and Development Department)
- 1 Naval Research Laboratory (Chemistry Division, Code 6130, R. R. Miller)
- 1 Naval Weapons Laboratory, Dahlgren (Technical Library)
- 2 Naval Weapons Services Office

ABSTRACT CARD

U. S. Naval Ordnance Test Station  
Engineering Properties of Explosively Work-Hardened Steels, by George A. Hayes and John Pearson. China Lake, Calif., NOTS, September 1962. 34 pp. (NAVWEPS Report 7953, NOTS TP 2994), UNCLASSIFIED.

○ (Over)  
1 card, 4 copies

U. S. Naval Ordnance Test Station  
Engineering Properties of Explosively Work-Hardened Steels, by George A. Hayes and John Pearson. China Lake, Calif., NOTS, September 1962. 34 pp. (NAVWEPS Report 7953, NOTS TP 2994), UNCLASSIFIED.

○ (Over)  
1 card, 4 copies

U. S. Naval Ordnance Test Station  
Engineering Properties of Explosively Work-Hardened Steels, by George A. Hayes and John Pearson. China Lake, Calif., NOTS, September 1962. 34 pp. (NAVWEPS Report 7953, NOTS TP 2994), UNCLASSIFIED.

○ (Over)  
1 card, 4 copies

U. S. Naval Ordnance Test Station  
Engineering Properties of Explosively Work-Hardened Steels, by George A. Hayes and John Pearson. China Lake, Calif., NOTS, September 1962. 34 pp. (NAVWEPS Report 7953, NOTS TP 2994), UNCLASSIFIED.

○ (Over)  
1 card, 4 copies

NAVWEPS Report 7953

ABSTRACT. An experimental study is discussed in which permanent changes were produced in the engineering properties of four annealed steels (1015, 1030, 1050, and 4130) by means of contact explosive charges of different thicknesses. Quantitative data is presented for explosively induced changes in proportional limit, yield strength, ultimate strength, fracture strength, elongation, and toughness for the four steels as related to charge thickness and distance from the metal-explosive interfaces.

NAVWEPS Report 7953

ABSTRACT. An experimental study is discussed in which permanent changes were produced in the engineering properties of four annealed steels (1015, 1030, 1050, and 4130) by means of contact explosive charges of different thicknesses. Quantitative data is presented for explosively induced changes in proportional limit, yield strength, ultimate strength, fracture strength, elongation, and toughness for the four steels as related to charge thickness and distance from the metal-explosive interfaces.

NAVWEPS Report 7953

ABSTRACT. An experimental study is discussed in which permanent changes were produced in the engineering properties of four annealed steels (1015, 1030, 1050, and 4130) by means of contact explosive charges of different thicknesses. Quantitative data is presented for explosively induced changes in proportional limit, yield strength, ultimate strength, fracture strength, elongation, and toughness for the four steels as related to charge thickness and distance from the metal-explosive interfaces.

NAVWEPS Report 7953

ABSTRACT. An experimental study is discussed in which permanent changes were produced in the engineering properties of four annealed steels (1015, 1030, 1050, and 4130) by means of contact explosive charges of different thicknesses. Quantitative data is presented for explosively induced changes in proportional limit, yield strength, ultimate strength, fracture strength, elongation, and toughness for the four steels as related to charge thickness and distance from the metal-explosive interfaces.