

UNCLASSIFIED

AD 289 404

*Reproduced
by the*

**ARMED SERVICES TECHNICAL INFORMATION AGENCY
ARLINGTON HALL STATION
ARLINGTON 12, VIRGINIA**



UNCLASSIFIED

NOTICE: When government or other drawings, specifications or other data are used for any purpose other than in connection with a definitely related government procurement operation, the U. S. Government thereby incurs no responsibility, nor any obligation whatsoever; and the fact that the Government may have formulated, furnished, or in any way supplied the said drawings, specifications, or other data is not to be regarded by implication or otherwise as in any manner licensing the holder or any other person or corporation, or conveying any rights or permission to manufacture, use or sell any patented invention that may in any way be related thereto.

CATALOGED BY ASTIA
AS AD NO. 289404*

FCRL - 62 - 560

DEPARTMENT OF PHYSICS
UNIVERSITY OF GHANA
LEGON GHANA

63-1-4
20
5838



ANNUAL SUMMARY
REPORT 1960—61
January 1962

EQUATORIAL STUDY OF IRREGULARITIES
IN THE IONOSPHERE

REPRODUCED UNDER
CONTRACT No. AF 61 (052)—421

RECEIVED
JAN 21 1962
AF 61 (052) 421

AD

AF 61 (052)-421

SR 1.

28th January, 1962.

SUMMARY REPORT No. 1

October 1960 through September 1961

EQUATORIAL STUDY OF IRREGULARITIES IN THE IONOSPHERE.

R.W.H. WRIGHT

Department of Physics
University of Ghana
Legon, Ghana.

The research reported in this document has been sponsored by the Cambridge Research Laboratories, OAR, through The European Office, Aerospace Research, United States Air Force.

CONTENTS

1. Field strength measurements on the transmissions from the Thule back-scatter sounder.
 - 1.1 Conclusions from the field strength measurements.
2. Measurements on the 16.570 Mc/s. pulsed transmissions from Freiburg.
3. Measurements on 20 Mc/s. WWV.
4. Back-scatter.
5. Investigation of sunset fading effect.
 - 5.1 Results from the investigation of sunset fading.
6. An investigation of irregularities in the night time equatorial F region.
7. The scattering of radio waves from the ionosphere.
8. References

DIAGRAMS

- Fig. 1. Monthly mean diurnal variations of strength of 17.695 Mc/s. signals from Thule.
2. Block diagram of equipment for recording 16.64 Mc/s. pulsed signals.
3. Delay - time record Freiburg - Accra, 9/7/61.
4. Circuit diagram of series-resonant 100 Kc/s. crystal oscillator.
5. Temperature-sensitive amplifier for oven control.
6. Power supply for temperature-sensitive amplifier.
7. Six stage frequency divider circuit.
8. Delay v. reflection height for Freiburg-Accra (4660 Km.)
9. Delay v. reflection height for Freiburg-Accra (4660 Km.)
10. Angle of arrival v. reflection height for Freiburg-Accra (4660 Km.)
11. Angle of arrival v. reflection height for Freiburg-Accra (4660 km.)
12. Monthly mean diurnal variation of strength of 20 Mc/s. WWV signals at Accra.
13. Total daily fading for period 21st May to 3rd November, 1961.
14. Mean diurnal variation of flutter rate, half-monthly averages.
15. Geographical distribution of F region irregularities investigated.

1. Field strength measurements on the transmissions from the Thule back-scatter sounder.

The field intensity monitoring equipment used for this experiment arrived in December, 1960, this equipment was originally designed for the study of polar blackouts, and has been fully described by D.S. Pratt. Part of the equipment was lost in shipment, and part was damaged, requiring some modification and improvisation before being put into operation. However, the basic layout was unchanged, consisting in three element Yagi aeriels feeding Collins R390 A receivers, the logarithmic outputs from which were recorded on a Honeywell Visicorder. The 12, 18, and 30 Mc/s. Yagi aeriels were mounted on a 53 foot aluminium tower constructed from 'Dexion' slotted angle. These aeriels were directed 11° W. towards Thule; as the bearing of Fairbanks is only a few degrees away from that of Thule it was possible to use the same set of aeriels in order to attempt the reception of signals from the latter station.

Preliminary measurements were started on 18th February, 1961, in order to assess the usefulness of the various Thule and Fairbanks channels. The results of these measurements showed that severe interference occurred on the twelve and eighteen Mc/s. channels of both stations, no interference was experienced on the thirty Mc/s. channels. Signals from the Arctic sounders were observed on one channel only, the eighteen Mc/s. Thule transmission. During the period 9th through 19th March frequencies adjacent to the 12.8595 Mc/s. and 17.695 Mc/s. Thule frequencies were monitored in order to find interference free channels in case a change on the sounder frequencies might be possible, it later transpired that such a change could not be made.

Regular monitoring of the 17.695 Mc/s. transmission started on 20th March, 1961, and has continued fairly continuously throughout the year. The results of these observations are shown in Fig. 1 in the form of mean diurnal variations in signal strength for each month, April through October, 1961. Between September 4th and November 22nd

the 30.600 Mc/s. Thule channel was monitored, but although the noise level was less than 1 uV. no signals were observed. Signals on the 11.8595 Mc/s. Thule frequency have been observed on two occasions only during a period of six months.

1.1 Conclusions from field strength measurements.

(a) Between the hours of 0600 and 0100 G.M.T., April through August, the strength at Accra of the 17.695 Mc/s. signals from Thule is normally greater than 1 uV. Mean diurnal variations in signal intensity for the months April through October 1961 are given in Fig. 1.

(b) The intensity of interfering signals on the twelve Mc/s. channels has caused monitoring on this frequency to be unrewarding, signals from Thule having been observed on two occasions only.

(c) The strength at Accra of thirty Mc/s. signals from Thule is normally below one microvolt at all times.

(d) The intensity of interfering signals on all channels other than thirty Mc/s. has caused the number of observations possible to be insufficient for a detailed analysis to be made.

2. Measurements on the 16.570 Mc/s. pulsed transmissions from Freiburg.

The equipment for recording pulse delays was described fully in Status Report No. 1. It consists of a stable crystal oscillator, frequency divider, and time base to provide a stable time reference, and a pulse receiver, cathode ray tube display and photographic recorder, a block diagram of the equipment is shown in Fig. 2.

Initial difficulties were experienced with the 350 Kc/s. reference crystal provided by the Ionospheren Institut, Breisach, as it did not provide the required frequency stability. In June, 1961, Freiburg changed to a 100 Kc/s. crystal of high stability. These transmissions were recorded at Accra using a 100 Kc/s. oscillator which

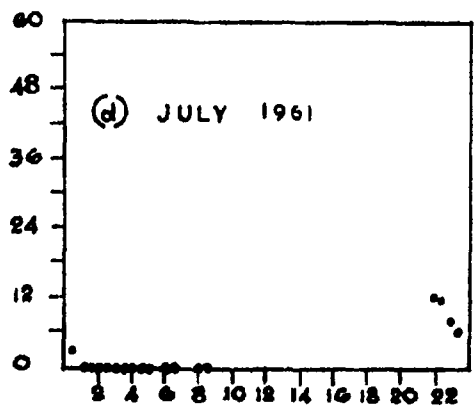
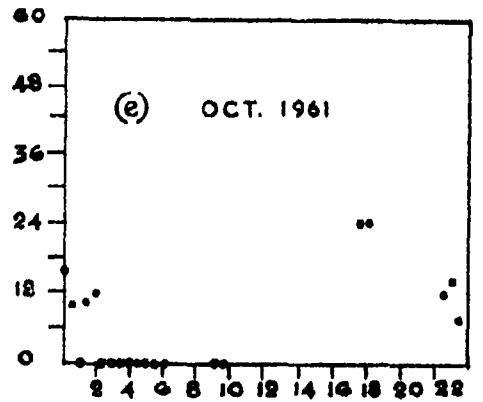
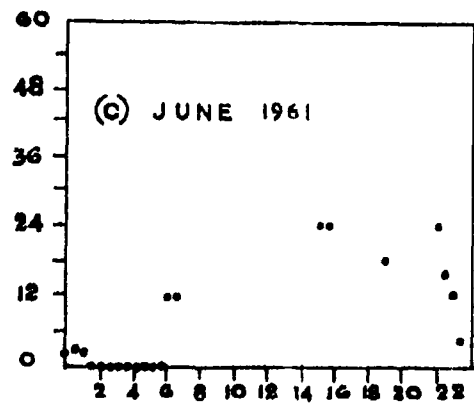
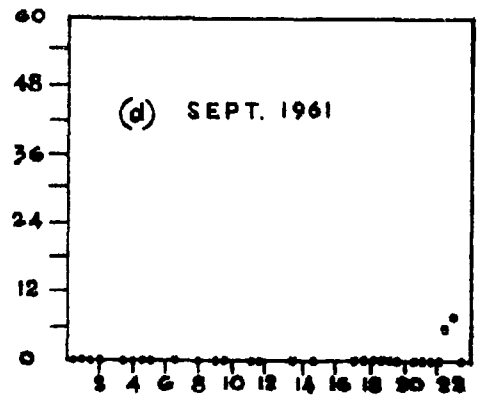
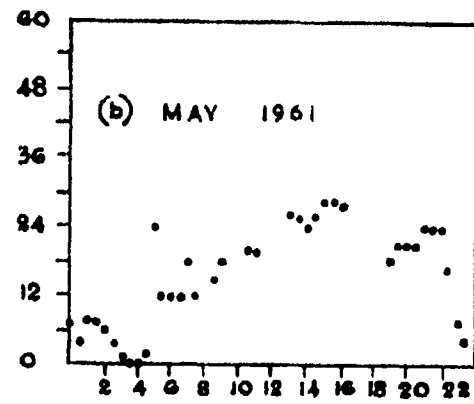
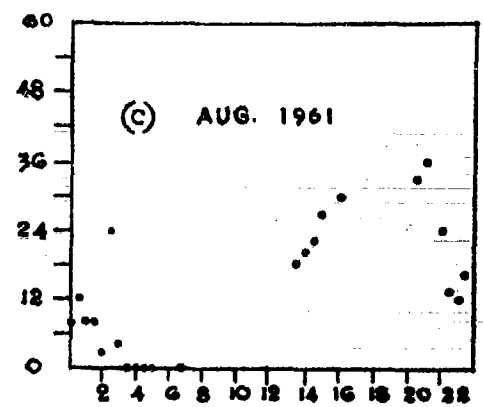
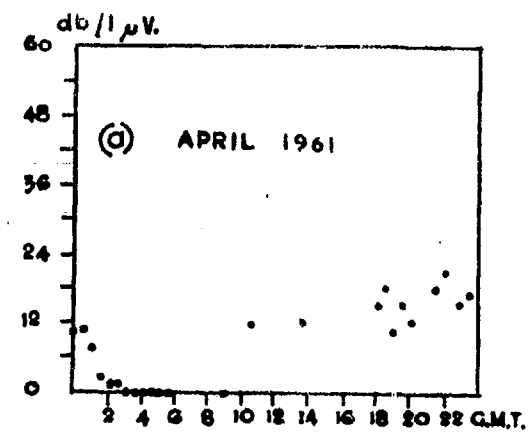

FIG. 1 MONTHLY MEAN DIURNAL VARIATIONS OF STRENGTH OF 17.695 Mc/s. SIGNALS FROM THUR.

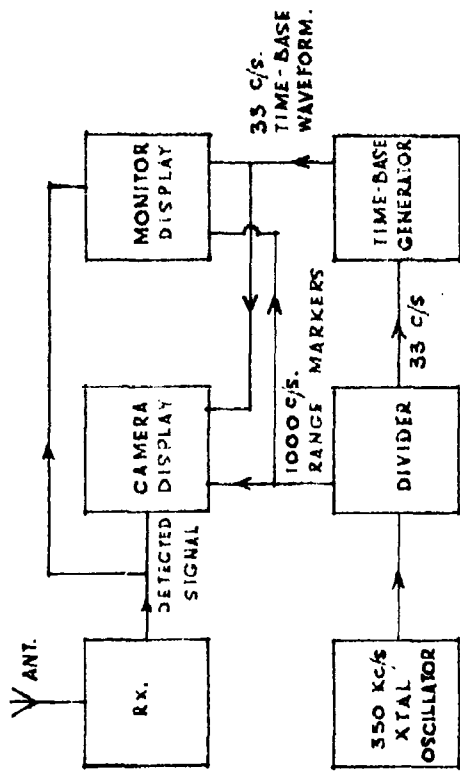

FIG. 2 BLOCK DIAGRAM OF EQUIPMENT FOR RECORDING 16.54 MC/S PULSED SIGNALS.

was available on loan in Accra, and a suitably modified divider circuit. The records obtained in this manner were found to be extremely complex in nature, the existence of as many as ten simultaneous modes making an immediate analysis of the records impossible; a reproduction of one of these records with the delay scale much expanded is shown in Fig. 3. These recordings were continued in the hope that the lower M.U.F.s associated with winter conditions in the northern hemisphere would decrease the number of simultaneous modes of propagation sufficiently to enable an identification of those remaining to be made. By the end of September a simplification in the records was becoming apparent, but at this time the 100 Kc/s. crystal had to be unexpectedly returned before the oscillator being constructed in the Physics Department was completed.

The oscillator under construction uses a $+5^\circ$ X cut crystal in a temperature stabilised oven at 45°C . The use of the comparatively low operating temperature of 45°C takes advantage of the turn-over point in the frequency-temperature characteristic of the crystal to reduce the effect of temperature fluctuations, and also reduces the rate of frequency drift caused by aging. The temperature stabilising circuit for the oven makes use of the dependence on temperature of the collector current of a transistor in the common base configuration. Circuit diagrams of the 100 Kc/s. oscillator, temperature control unit, and frequency divider are shown in Figs. 4, 5, 6 and 7. The temperature control circuit was developed from a circuit published by Pallet (1961), and the oscillator from a circuit by Fairweather and Richards. The entire temperature control circuit with the exception of the final power transistor controlling the current to the heater winding, is enclosed in the constant temperature oven. After aging the oscillator should have a stability of the order of two parts in 10^8 per day.

In order to assist the analysis of delay records, the relative delays for various modes of propagation over the Freiburg-Accra path have been calculated for the simple case of specular reflection from E and F layers of uniform height. Figs. 8, 9, 10 and 11 show relative delay and angle of arrival for various F, F + E, and F + 2E modes.

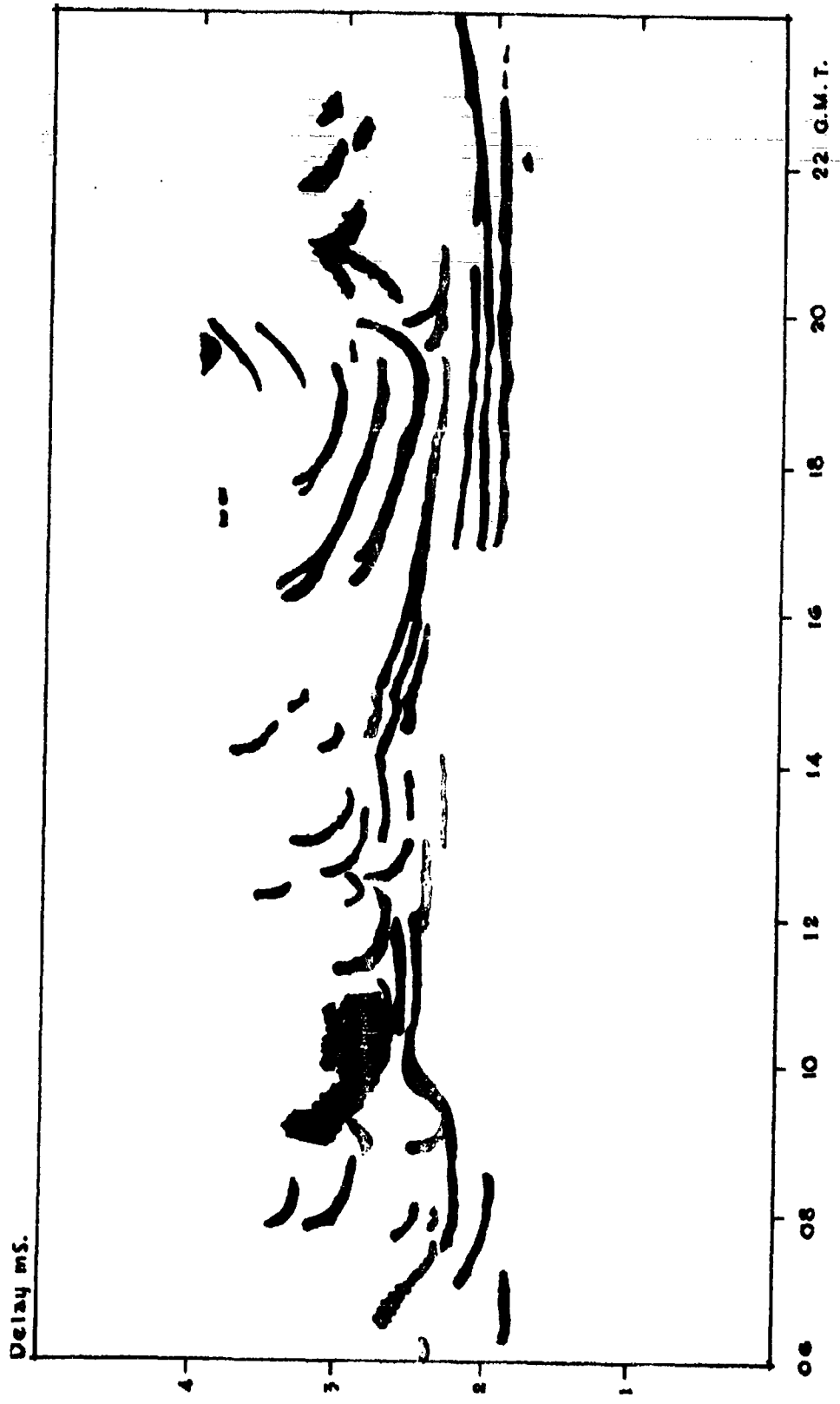

FIG. 3 DELAY - TIME RECORD FREIBURG-ACCRA, 9/7/61

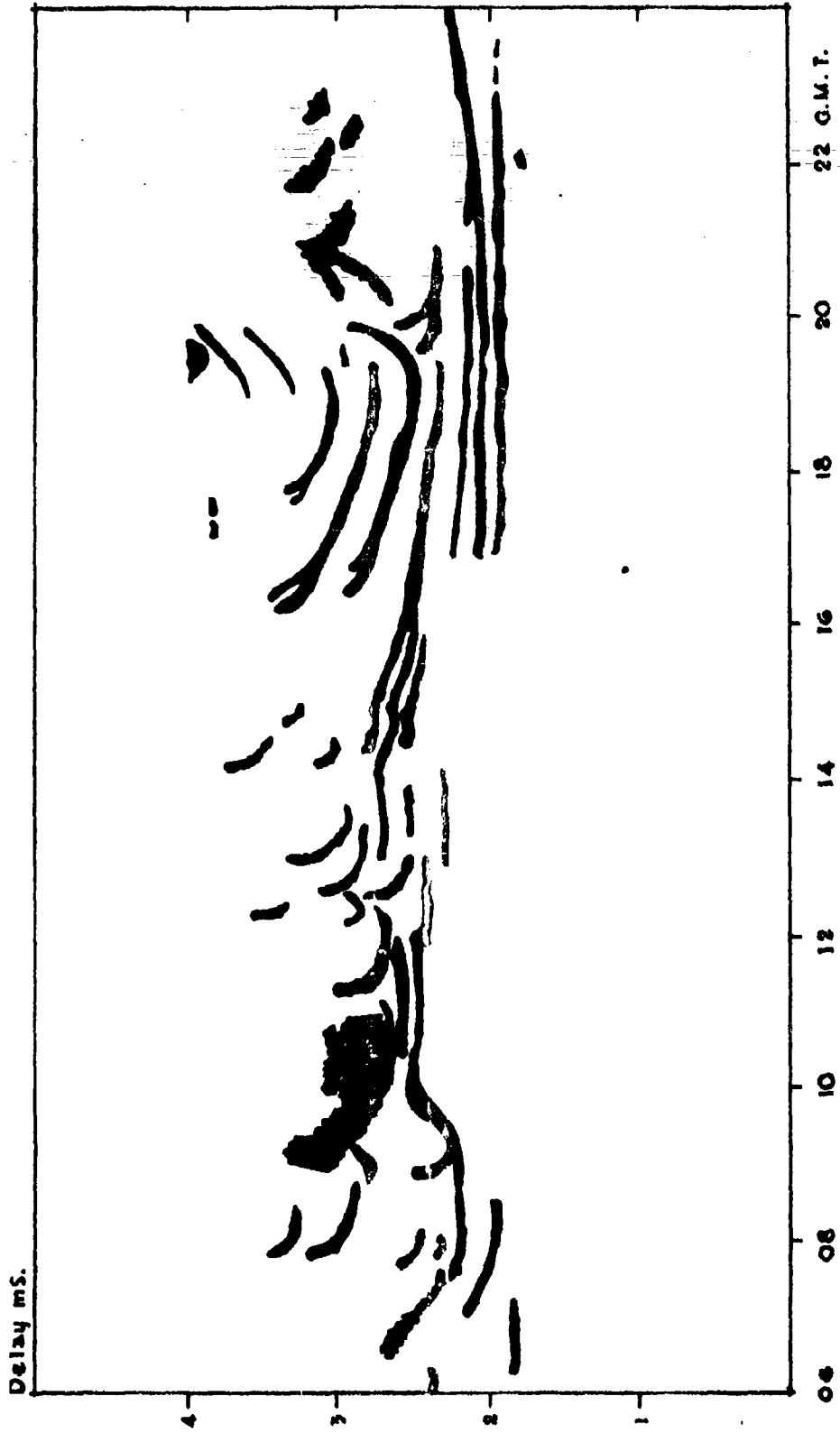

FIG. 3 DELAY - TIME RECORD FREIBURG--ACCRA, 9/7/61

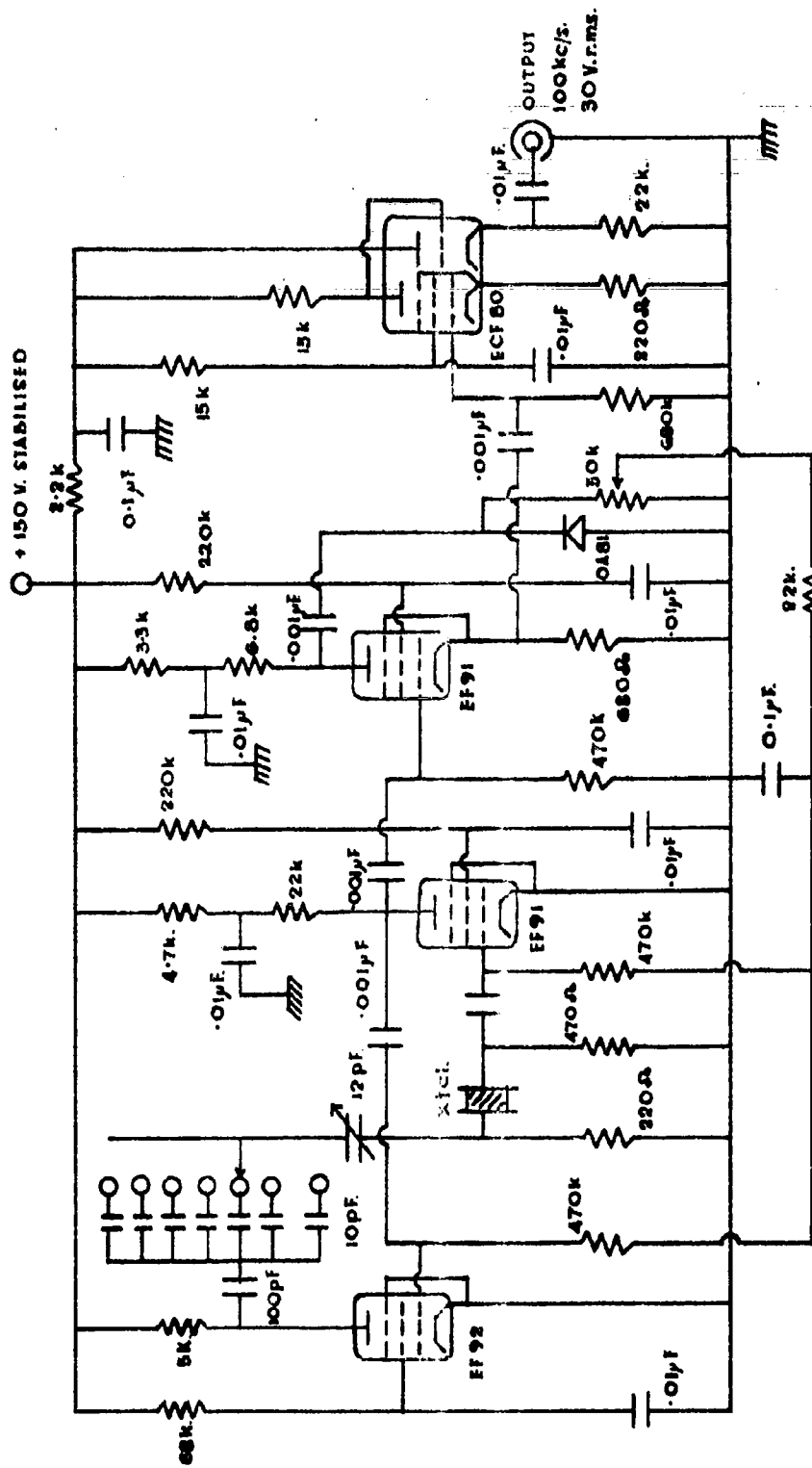

FIG. 4 CIRCUIT DIAGRAM OF SERIES - RESONANT 100 KC/S. CRYSTAL OSCILLATOR.

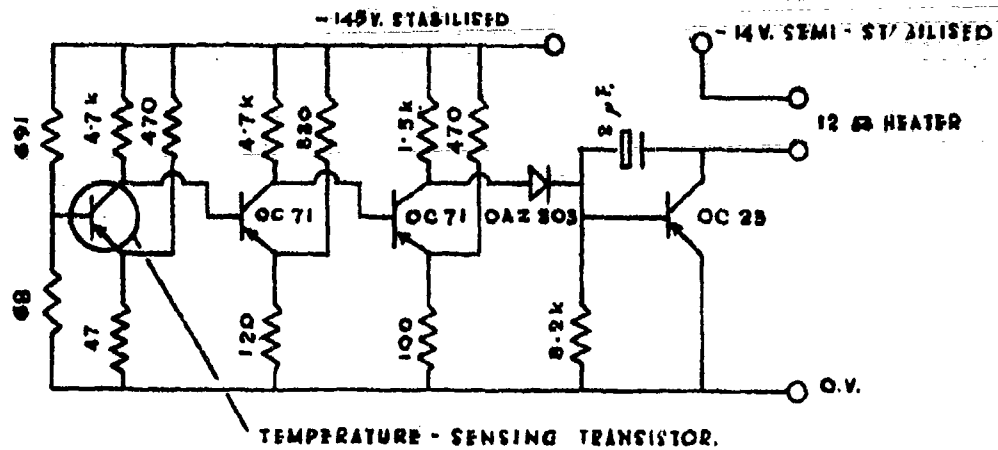

FIG. 5 TEMPERATURE - SENSITIVE AMPLIFIER FOR OVEN CONTROL.

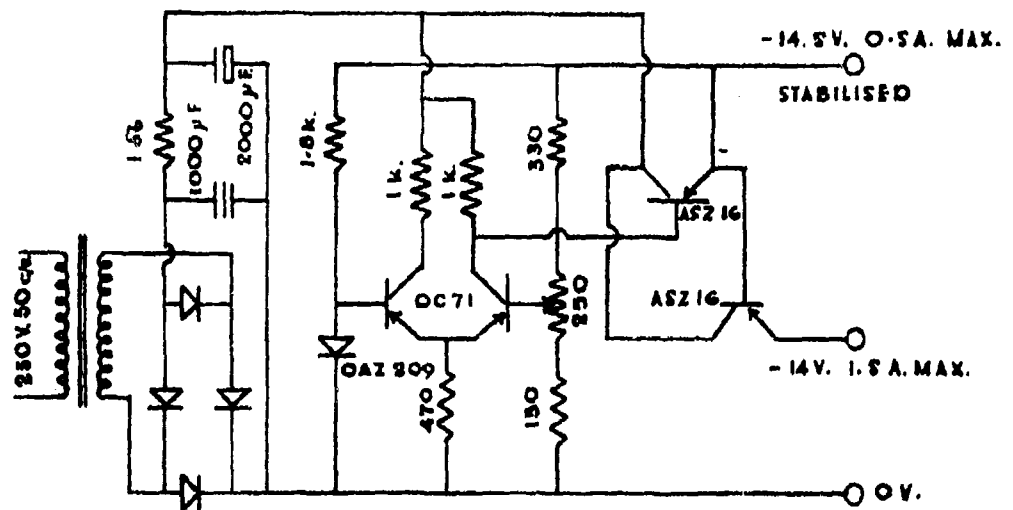

FIG. 6 POWER SUPPLY FOR TEMPERATURE - SENSITIVE AMPLIFIER.

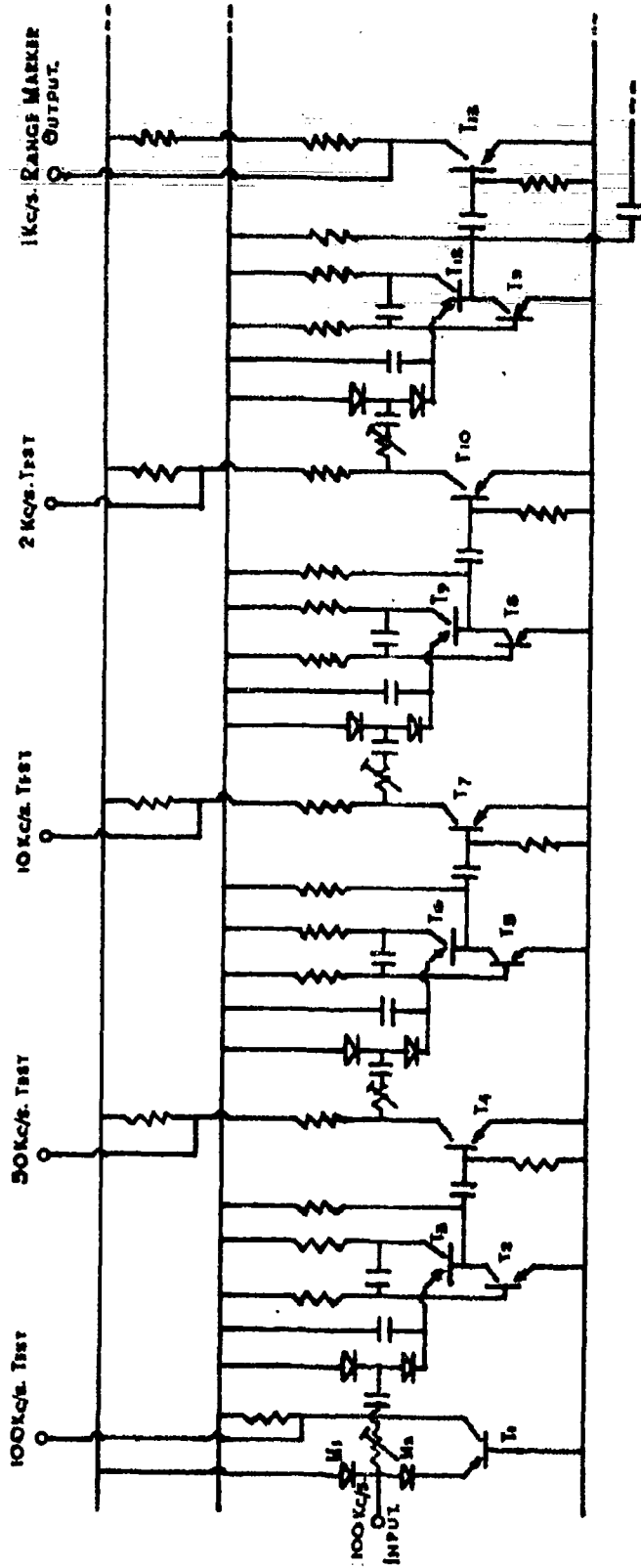

FIG. 7 SIX STAGE FREQUENCY DIVIDER CIRCUIT

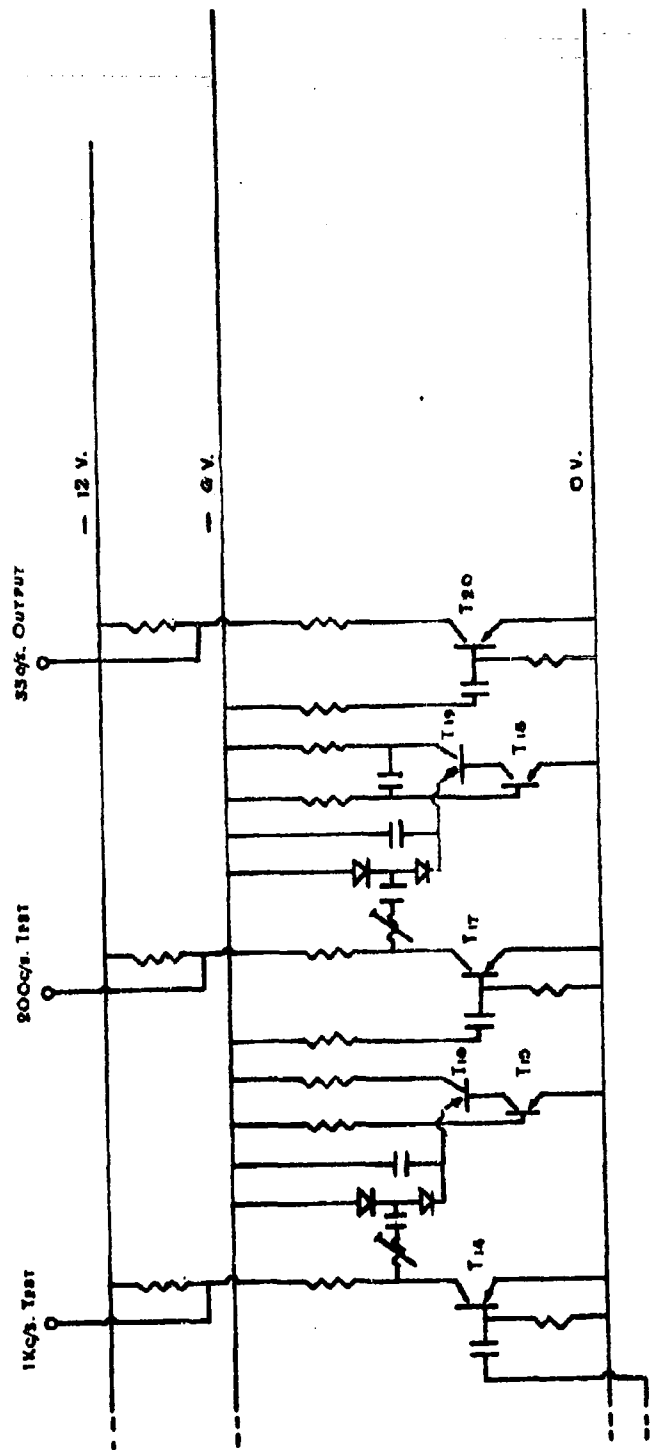

FIG. 7 CONTINUED

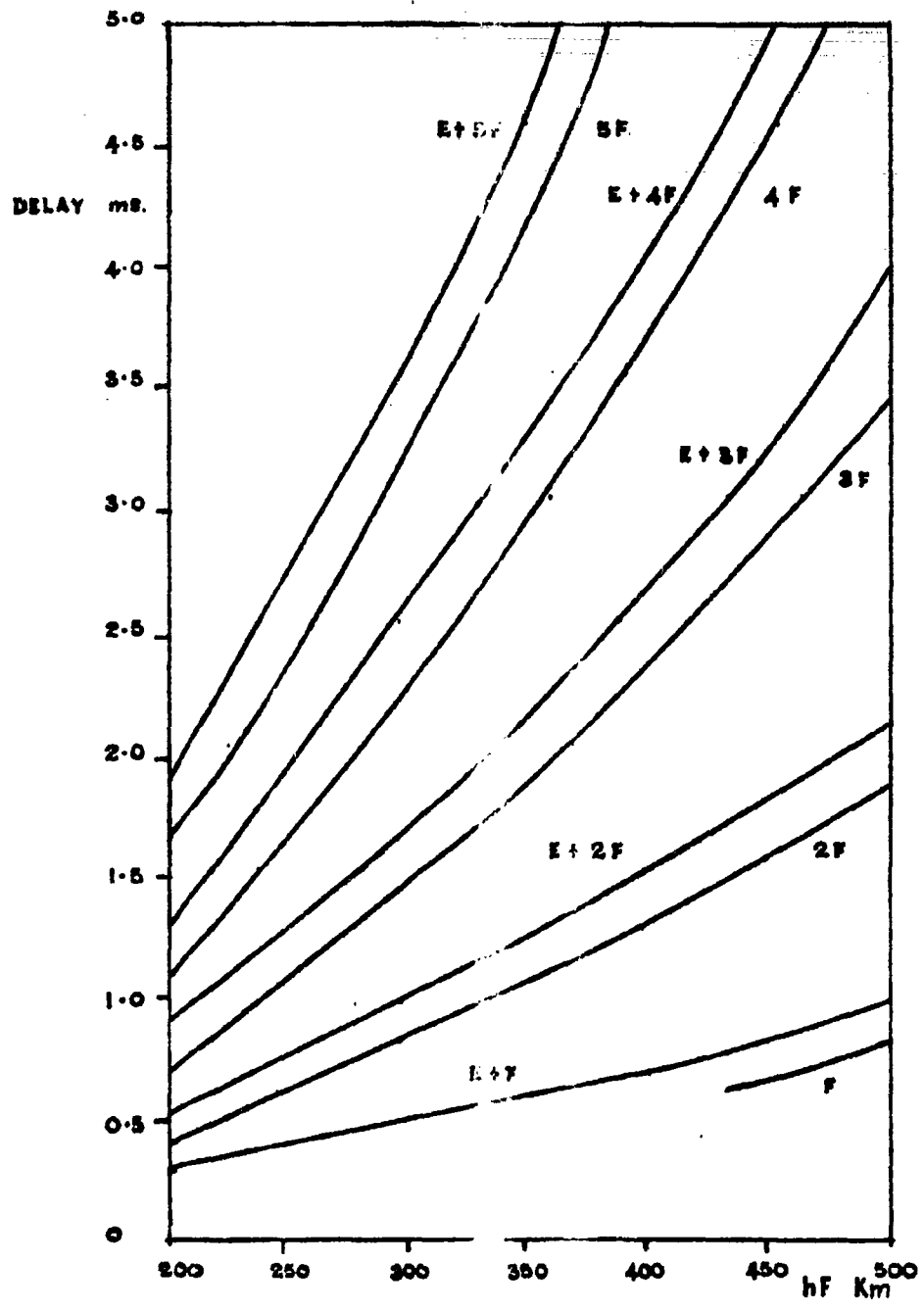

FIG. 8 DELAY V. REFLECTION HEIGHT FOR FREIBURG-ACCRA (4660 Km.)

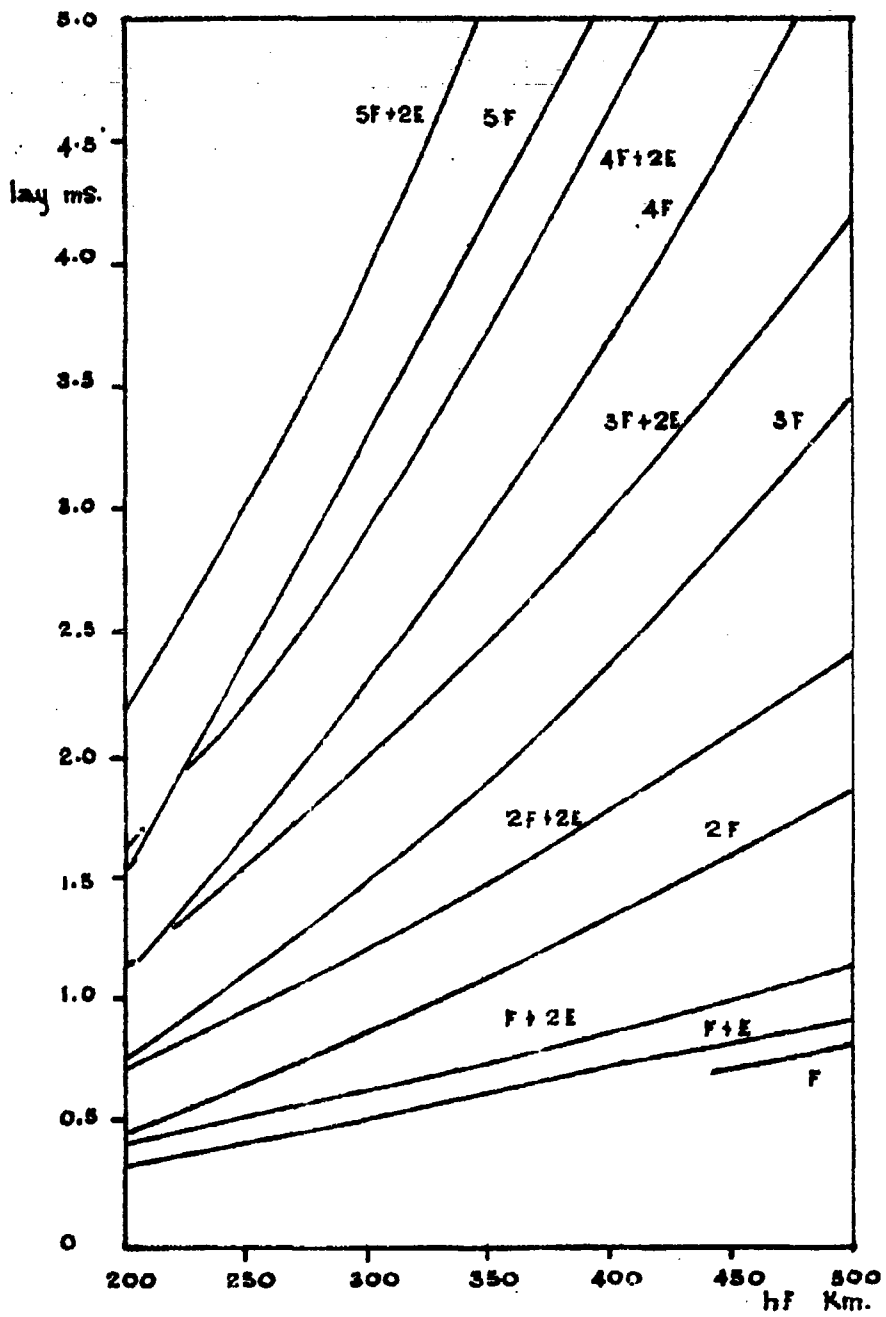

FIG. 9 DELAY V REFLECTION HEIGHT FOR FREIBURG-ACCRA (4660 Km)

Angle of arrival degrees.

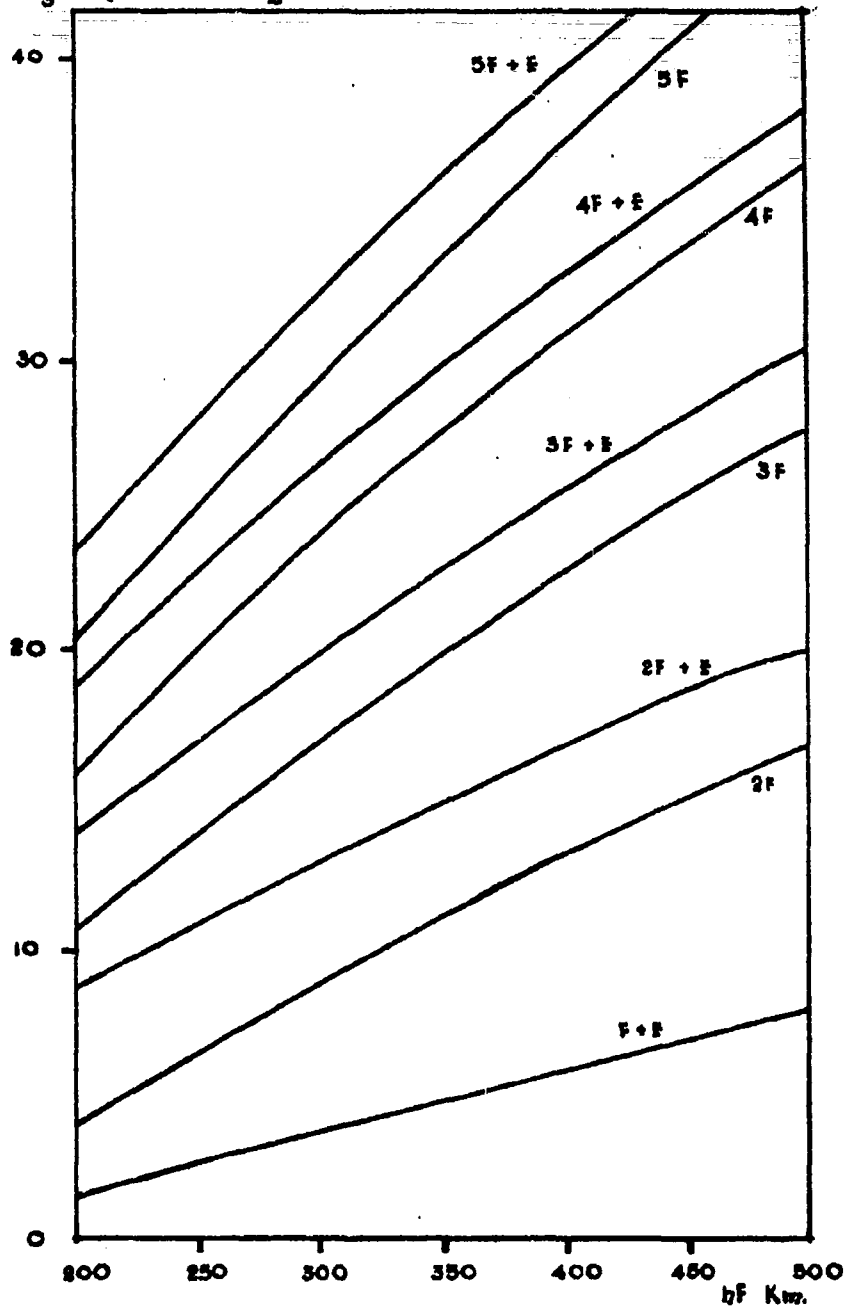

FIG.10 ANGLE OF ARRIVAL V. REFLECTION HEIGHT FOR FREIBURG-ACCRA (4460km)

Angle of arrival degrees.

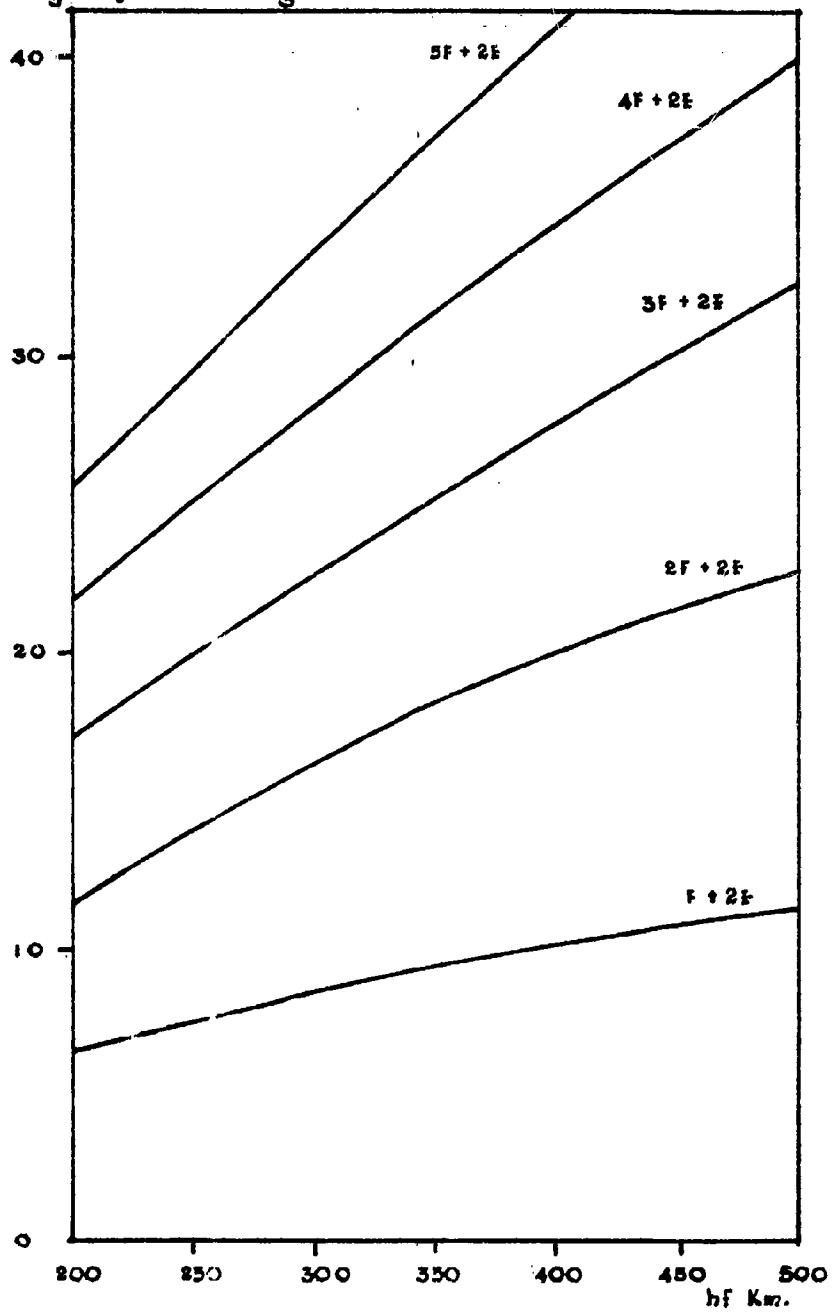

FIG. II ANGLE OF ARRIVAL V. REFLECTION HEIGHT FOR FREIBURG—ACCRA (4660 Km.)

3. Measurements on 20 Mc/s. WWV.

During the months of May, June, July, and August, 1961, recordings of the signal strength of the 20 Mc/s. transmissions from the WWV transmitter in Washington were made at Accra for the purpose of comparison with the Thule measurements. The equipment used consisted of a half wave dipole aerial 1.5 wavelengths above the ground feeding a narrow bandwidth receiver, the logarithmic carrier level output of which was recorded on an Esterline Angus pen recorder.

Fig. 12 shows the monthly mean diurnal variations in signal strength for the four months, expressed in terms of db. above one microvolt.

4. Back-scatter.

It was originally intended that back-scatter soundings should be made using an I.C.Y. type back-scatter sounder to be provided by the U.S.A.F., it later appeared that an I.G.Y. sounder was not available. Towards the end of the period covered by this report a prototype Raytheon Cozi sounder became available. This consists of a transmitter tunable to any one of six crystal controlled channels, pulse modulator, receiver, duplexer, and an A scan display unit. The transmitter peak power is about 1 Kw., and the pulse duration is variable from 0.5 to 2.5 mS. Some initial difficulties were experienced with this equipment owing to the fact that no crystals were shipped with the equipment, and no circuit diagram of the transmitter was provided.

It is intended to use the back-scatter sounder in order to investigate irregularities in F region, and, if the limited resolution of the equipment permits, the E region. In order to make some assessment of the sensitivity of the equipment and the feasibility of its use in observing direct back-scatter from F region irregularities, the equipment was initially operated with an eighteen Mc/s. three element Yagi aerial directed vertically upwards. It was noted that during the

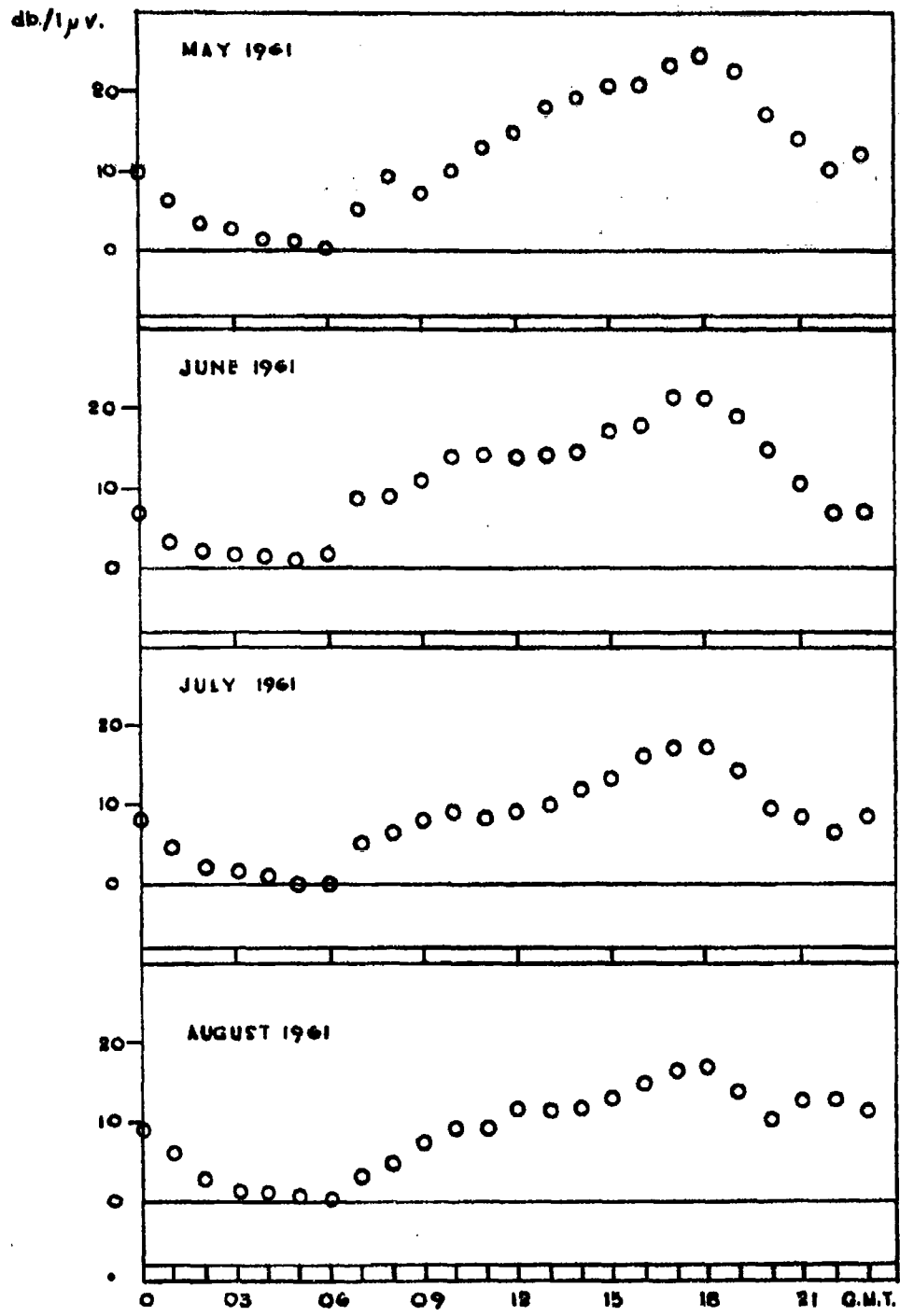

FIG.12 MONTHLY MEAN DIURNAL VARIATION OF STRENGTH OF 20 Mc/s. WWV. SIGNALS AT ACCRA.

presence of spread F, weak echoes were received from heights corresponding to the F region heights recorded at lower frequencies by a standard ionosonde. It was further noted that during the presence of extra severe radio star scintillation (Koster, 1958), enhanced echoes were observed on the eighteen Mc/s. back-scatter frequency. The range of these echoes was observed to decrease from 800 Km. to 200 Km. during a period of about twenty minutes. A possible explanation of this phenomenon is that the echoes originate from a drifting cloud of intensely disturbed ionisation. In order to investigate this phenomenon more closely, and to provide a versatile tool for further experiment, a fully steerable eighteen Mc/s. aerial system is being constructed. This aerial is capable of being rotated both in azimuth and in elevation, and is arranged to give either horizontal or vertical polarisation to the exploring wave. Remote control of the aerial is achieved by means of transistorised servo-control circuits, and provision is made for automatic operation in the form of continuous sweep of azimuth and/or elevation. Modifications are being made to the Gozi sounder in order to improve the range resolution of this equipment, in particular, provision is being made for the suppression of the ground pulse at the receiver in order to enable shorter delays to be measured.

5. Investigation of sunset fading effect.

The principal object of this experiment was to investigate the rapid flutter type of fading common at equatorial locations. Continuous data over an extended period of time is required for the purpose of determining the diurnal and annual variations of this fading, and correlating this effect with other equatorial ionospheric phenomena.

Throughout the period of the investigation the signal used was the B.B.C. transmission to West Africa on 15.07 Mc/s. Signals were received on a simple folded dipole suspended 5.5 metres above the ground. The receiver was a Collins R390 A slightly modified to give an A.G.C. time constant of 20 seconds. The I.F. output of the receiver was used to operate a fade rate meter of the type described by Harding, Janson and Koch, via a single stage amplifier. The A.G.C. voltage of the receiver, suitably amplified, was also recorded to give a measure of

signal strength on a conveniently logarithmic scale. Both signal strength and fading rate were recorded continuously at 3 inches per hour on an Evershed and Vignoles twin strip chart recorder. The two equipments were calibrated daily.

Experiment showed that whenever the signal strength dropped to a level of about 20 db. above one microvolt at the receiver input, the fading rate meter began to record spurious counts due to the general background noise. Hence in the later analysis all fading rate records were rejected for occasions when the signal voltage at the receiver input dropped to less than 30 db. relative to one microvolt. This rarely occurred except in the early morning hours by which time flutter fading has usually disappeared. From the remaining records values of the fading rate were tabulated for each twenty minute interval. It was also desired to fix a unit of 'total amount of fading' for each night. This was defined as the total area under the fading rate v. time curve, and was measured in practice by taking the sum of the twenty minute fading rate values for the entire night.

5.1 Results from the investigation of sunset fading.

The results are summarized in Figures 13 and 14. Fig. 13 shows the total amount of fading for each day from 1st May through 3rd November, 1961. In making the summations of hourly fading rates, all fading rates less than 3 c/s. were excluded in order to emphasise the distribution of severe flutter fading. A further reason for the rejection of low count rates lies in the fact that minor instrumental faults can give a spurious count rate of one or two counts per second, which, summed over an entire night, would give the impression of pronounced flutter fading, when in reality there was little or none. It is clear from the figure that fast flutter fading is distinctly an equinoctial phenomenon, though an occasional case of flutter fading may occur at other seasons.

Fig. 14 is mainly intended to show the daily variation, but it also shows the seasonal effect. The curves show the mean value of

FLUTTER RATE G/S.

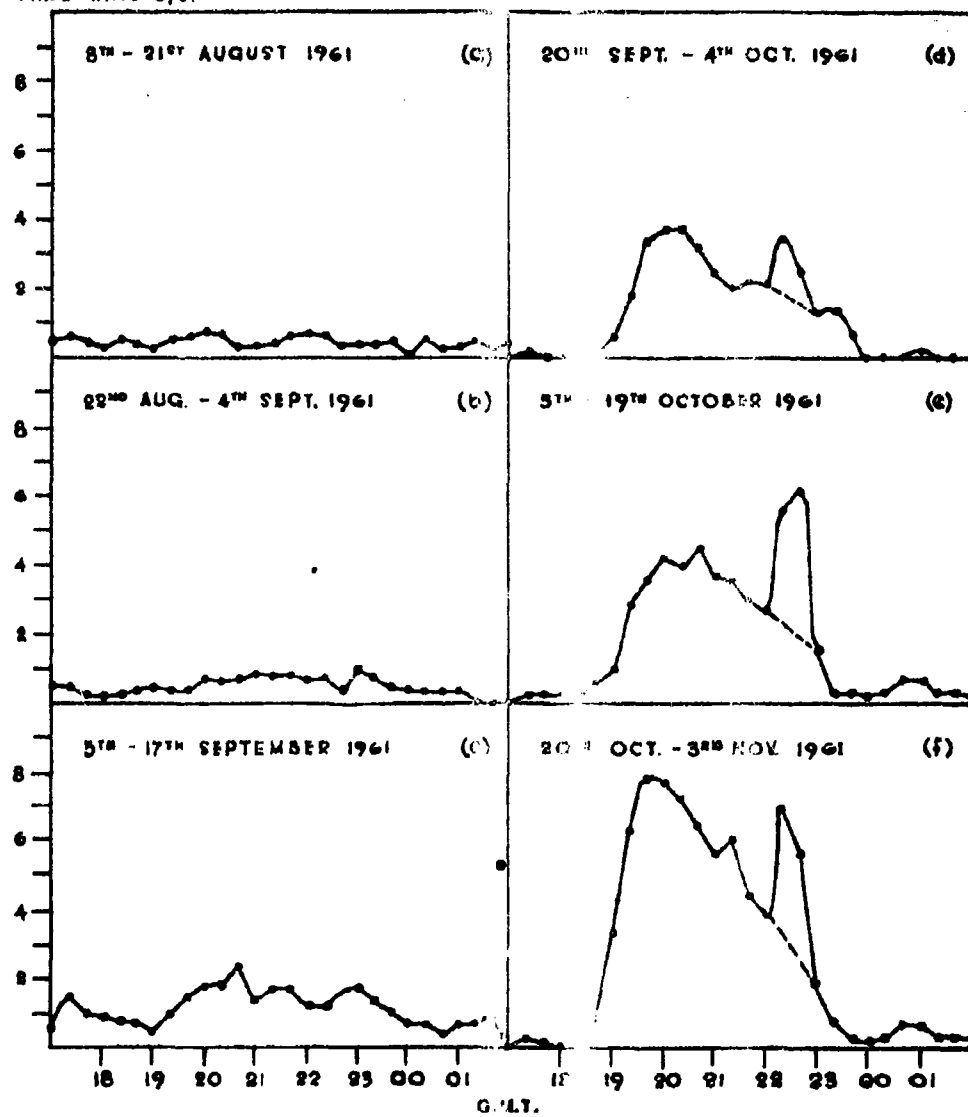

FIG.14 MEAN DIURNAL VARIATION OF FLUTTER RATE, HALF-MONTHLY AVERAGED.

fading rate versus time for fortnightly intervals between August 8th and November 3rd. The curves agree well in showing a rapid rise in fading rate at about 18.30 G.M.T., a maximum at 19.30 G.M.T. to 20.30 G.M.T., and then a slow nearly exponential fall. Fading rate was normally very near to zero by midnight on almost all days. No 'sunrise' fading effect was observed. All the curves show a marked rise in the fading rate for the two points at 22.15 and 22.45 G.M.T. This is not a genuine ionospheric effect. It is evident from the signal strength records that the received signal strength dropped abruptly at approximately 22.10 G.M.T., and rose again about forty minutes later. The final explanation is not certain, but it would appear that the B.B.C. transmission being used for this investigation was switched to a different aerial during this interval, probably bearing the signal in a different direction, or at a different take off angle.

The correlation of fading rate with radio star scintillation, spread F and other geophysical phenomena still remains to be done.

6. An investigation of irregularities in the night time equatorial F region.

This experiment, conducted at Legon by Dr. J.R. Koster, of the University of Ghana, and Dr. G.S. Kent, of the University College, Ibadan, has been fully reported in the form of Technical Note (Kent and Koster, 1961). The purpose of the experiment was to determine the height of the irregularities in the night time equatorial F region which give rise to the scintillation of satellite signals. The results are summarised here in Table 1, the approximate positions of the irregularities associated with each observation being shown in Fig. 15. It will be noted that the effective height of the irregularities always lies between 50 Km. and 100 Km. above the base of the F layer. The values of height may be compared with the results Cohen and Bowles (1961) who found that the irregularities which they observe lie at or near the base of the F layer.

SCALE $1 : 8 \times 10^6$

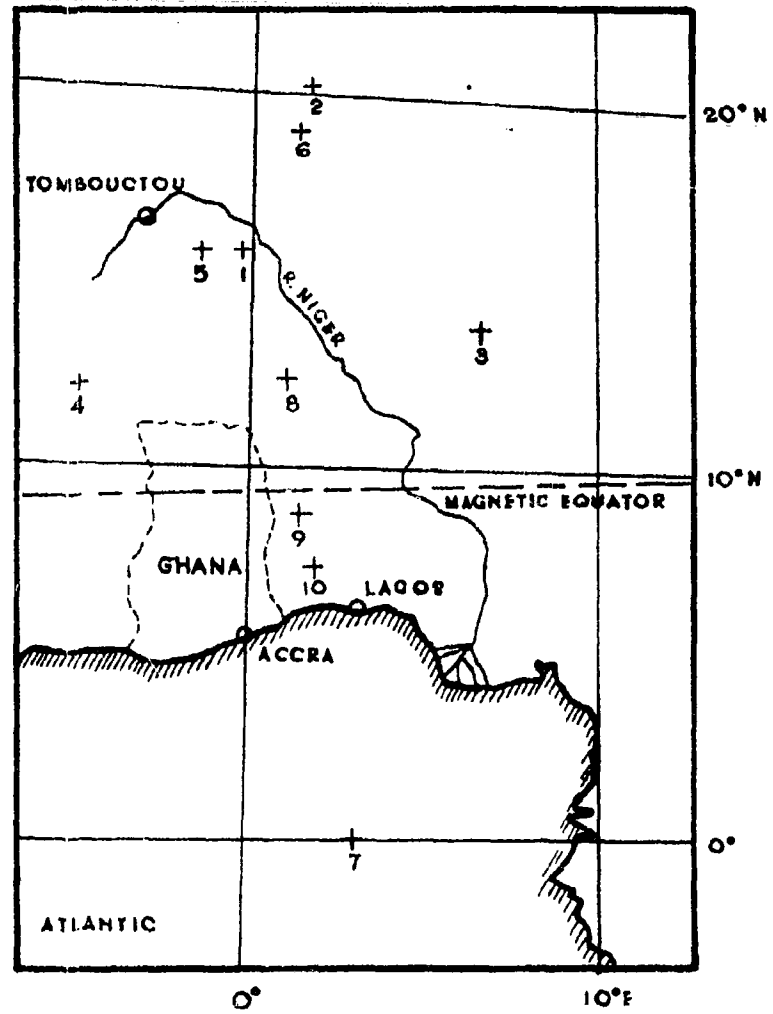

FIG. 15 GEOGRAPHICAL DISTRIBUTION OF F REGION
IRREGULARITIES INVESTIGATED.

Table 1

No.	Date	U.T.	Height of base of F layer	Height of irregularities
1	22/6/61	22:01:03	350 km.	424 km.
2	22/6/61	22:02:01	350	401
3	23/6/61	20:56:04	360	416
4	24/6/61	21:27:02	300	402
5	24/6/61	21:29:00	300	396
6	24/6/61	21:30:06	300	380
7	9/7/61	02:33:54		395
8	10/7/61	01:22:30		427
9	12/7/61	00:51:07	260	354
10	12/7/61	00:52:07	260	314

7. The scattering of radio waves from the ionosphere.

During the period covered by this report a theoretical study of the scattering of medium frequency radio waves in the lower ionosphere was conducted by Professor R.W.H. Wright and Mr. B.R. Clemo. This study has been published (Clemo and Wright, 1962) and will be further reported in the form of a Technical Note. The investigation demonstrates that the apparent maximum in the back-scatter of medium wave radio signals which occurs at heights in the region of 70 km. (Gardner and Pawsey, 1953), does not, as has hitherto been assumed, require the postulation of a maximum in the electron density or the intensity of irregularities at this height.

8. REFERENCES

- Clemesha, B.R. & Wright, R.W.H. Nature, 193, 54, (1962)
- Cohon, R. & Bowles, K.L. J.G.R., 66, 1081, (1961)
- Gardner, F.F. & Pawsey, J.L. J. Atmos, Terr. Phys. 3, 321 (1953)
- Fairweather, D. & Richards, R.C. Marconi Monograph, 'Quartz crystals as oscillators and resonators'.
- Harding, Jansen, and Koch N.B.S. Report No. 6046, 'Fading rate recorder'.
- Kent, G.S. & Koster, J.R. Nature, 191, 1083 (1961) and T.R. No. 1 reproduced under Contract AF 61 (052)-421
- Koster, J.R. J. Atmos. Terr. Phys. 12, 100, (1958)
- Pallett, J.E. Electronic Engineering, 33, 360, (1961)
- Pratt, D.S. Radio propagation lab. Stanford University. 'A field intensity recorder for the study of polar blackouts'. Reproduced under Contract AF 19(604)-4103.

UNIVERSITY OF
GHANA, LEGON,
GHANA.

AF 61 (052)-421
SR 1
GEOPHYSICS

28th Jan., 1962

EQUATORIAL STUDY OF IRREGULARITIES IN THE
IONOSPHERE.

R.N.H. Wright

ABSTRACT: Summary of work on oblique
transmission, Thule-Accra, Freiburg-Accra,
Washington-Accra, Flutter Landing, measurement
of height of F region irregularities, and
vertical incidence back-scatter of radio waves
from below the E region.

UNIVERSITY OF
GHANA, LEGON
GHANA.

AF 61 (052)-421
SR 1
GEOPHYSICS

28th Jan., 1962

EQUATORIAL STUDY OF IRREGULARITIES IN THE
IONOSPHERE.

R.N.H. Wright

ABSTRACT: Summary of work on oblique
transmission, Thule-Accra, Freiburg-Accra,
Washington-Accra, Flutter Landing, measurement
of height of F region irregularities, and
vertical incidence back-scatter of radio waves
from below the E region.

UNIVERSITY OF
GHANA, LEGON,
GHANA.

AF 61 (052)-421
SR 1
GEOPHYSICS

28th Jan., 1962

EQUATORIAL STUDY OF IRREGULARITIES IN THE
IONOSPHERE.

R.N.H. Wright

ABSTRACT: Summary of work on oblique
transmission, Thule-Accra, Freiburg-Accra,
Washington-Accra, Flutter Landing, measurement
of height of F region irregularities, and
vertical incidence back-scatter of radio waves
from below the E region.

UNIVERSITY OF
GHANA, LEGON,
GHANA.

AF 61 (052)-421
SR 1
GEOPHYSICS

28th Jan., 1962

EQUATORIAL STUDY OF IRREGULARITIES IN THE
IONOSPHERE.

R.N.H. Wright

ABSTRACT: Summary of work on oblique
transmission, Thule-Accra, Freiburg-Accra,
Washington-Accra, Flutter Landing, measurement
of height of F region irregularities, and
vertical incidence back-scatter of radio waves
from below the E region.