

UNCLASSIFIED

AD 290 051

*Reproduced
by the*

**ARMED SERVICES TECHNICAL INFORMATION AGENCY
ARLINGTON HALL STATION
ARLINGTON 12, VIRGINIA**



UNCLASSIFIED

NOTICE: When government or other drawings, specifications or other data are used for any purpose other than in connection with a definitely related government procurement operation, the U. S. Government thereby incurs no responsibility, nor any obligation whatsoever; and the fact that the Government may have formulated, furnished, or in any way supplied the said drawings, specifications, or other data is not to be regarded by implication or otherwise as in any manner licensing the holder or any other person or corporation, or conveying any rights or permission to manufacture, use or sell any patented invention that may in any way be related thereto.

①

62-1-5

TECHNICAL INFORMATION SERIES

290051

R62SD86

**THE ABLATION OF GRAPHITE IN DISSOCIATED
AIR—EXPERIMENTAL INVESTIGATION**

290 051

**N.S. DIACONIS, P.D. GORSUCH
and R.A. SHERIDAN**

819 485

SPACE SCIENCES LABORATORY

GENERAL  ELECTRIC

MISSILE AND SPACE DIVISION

#3.60

SPACE SCIENCES LABORATORY

THE ABLATION OF GRAPHITE IN DISSOCIATED AIR
PART II: EXPERIMENTAL INVESTIGATION*

By

N. S. Diaconis
P. D. Gorsuch
R. A. Sheridan

*Presented at the IAS National Summer Meeting,
Los Angeles, California, June 19-22, 1962

R62SD86 - Class I
September, 1962

MISSILE AND SPACE DIVISION

GENERAL  ELECTRIC

TABLE OF CONTENTS

	PAGE
Abstract	i
List of Symbols	ii
I. Introduction	1
II. Flight Environments	2
III. Ground Test Requirements	5
IV. Electric Arc Heated Test Facilities	7
V. Test Program	8
VI. Results and Discussion	14
VII. Concluding Remarks	17
Acknowledgement	19
References	20
Figures	

THE ABLATION OF GRAPHITE

IN DISSOCIATED AIR

Part 2 - Experiment

N. S. Diaconis, P. D. Gorsuch, R. A. Sheridan

ABSTRACT

↓
An experimental investigation was conducted to study the oxidation performance of ATJ graphite in dissociated air. To characterize the behavior of such a material in a re-entry environment requires the proper simulation of certain free flight flow field parameters which greatly influence material performance. For good experimental simulation it is desirable to establish in the test facility at least the following: stagnation enthalpy of the gas stream, model pressure, flow chemistry and aerodynamic shear.

Tests were conducted in a hypersonic arc wind tunnel in which the material mass loss was correlated as a function of model surface temperature. The data obtained indicated two specific zones of material performance, one in which the rate of the reaction between the oxygen species and the material governs the mass loss and the other in which the rate of diffusion of the oxygen-bearing species to the surface is dominant. Comparison of these experimental data with the theory of Scala showed good agreement.

SYMBOLS

h_s	stagnation enthalpy
U	free stream velocity
P_s	stagnation pressure
P_e	static pressure at edge of boundary layer
\dot{Q}	heat transfer rate
T_w	wall temperature
T_s	gas stagnation temperature
\dot{m}_w	mass transfer at wall
R_B	body radius
RT_o	33.86 BTU/lb.
t	time
(W/A)	weight per unit area
\AA	angstrom units
ppm	parts per million
A/A^*	ratio of nozzle exit to throat area

I. INTRODUCTION

Although thermal protection systems for ballistic missile and satellite re-entry vehicles have been flown successfully, continued interest exists in improved designs. While better materials are being developed for performing existing missions more efficiently, expanded mission requirements are also dictating increased performance for heat protection systems. Because of exhibited high temperature capabilities graphites continue to receive considerable attention for thermal protection applications. However, insufficient material property characterization at high temperatures and the lack of adequate design experience with brittle materials has instilled in the designer a reluctance to use materials such as graphite. An increased emphasis on the proper characterization and evaluation of the physicochemical properties of these materials is required. The purpose of this paper is to discuss such a study -- an experimental determination of the performance of a graphite material in a simulated hypersonic re-entry environment.

In the past the problems associated with the use of graphites as electrodes for various industrial applications have received considerable attention. Although these material requirements are quite severe, primarily from the thermal shock standpoint, one cannot interpret data from such studies in terms of performance in a re-entry vehicle environment. Not only must we expose thermal shield materials to high temperature environments associated with re-entry but we must do this in a manner which will simulate the aerodynamic parameters of the flow field. While one cannot economically simulate all the flight parameters simultaneously in a ground based test facility,

meaningful material response and subsequent proper evaluation requires the establishment of appropriate magnitudes for a number of key parameters which identify the test flow field.

II. FLIGHT ENVIRONMENTS

Before one can state what the detailed requirements are for the conduction of experimental investigations leading towards the generation of eventual design criteria for new materials, it is necessary to identify the types of re-entry vehicles of interest and examine the imposed environmental conditions. Typical vehicles that concern us today and in the foreseeable future for earth re-entry are high performance ballistic missiles, manned and unmanned satellites from earth orbit or lunar missions, and other space probes into the solar system which require return to earth. The problem of re-entry into other planetary atmospheres is not being considered here. Since those atmospheres involve gaseous mixtures different than those in the terrestrial environment, thermal shield performance of many of the presently characterized (in air) materials must be re-examined in test flows of the appropriate gas species.

It is seen from Fig. 1 where projected flight regimes of the various missions of interest for re-entry vehicles are shown, that the operational spectrum is rather broad, both within the various classes of vehicles and from one vehicle to the other. Surface pressure forces can vary by four orders of magnitude, flight velocity three or four fold and gas stagnation enthalpy by an order of magnitude over the range indicated. As shown, the ICBM penetrates to low altitude before it begins appreciable deceleration;

it will consequently experience rather high heating rates. The satellite, on the other hand, begins its deceleration at much higher altitudes; therefore its heating pulse will be much less severe but will extend over a longer period of time than that of the ballistic vehicle. Lunar probes and space probes re-entering at super-orbital velocities will experience a very wide range of stagnation point heating rate associated to ballistic environments on the one hand and satellite environments on the other; simultaneously, their re-entry times will be long (much longer than the ballistic vehicle). Because specific missions might require more than a minimum energy approach space probes are shown operating at greater than escape velocity. The salient features of Fig. 1 are therefore (a) that the re-entry map of concern encompasses a broad range of vehicle velocity or equivalently gas stagnation enthalpy ($h_s \approx \frac{u_\infty^2}{2}$) and (b) that the different mission requirements dictate primary vehicle deceleration at both high and low altitudes which significantly influences the imposed thermal environments.

On the next figure (Fig. 2) superimposed on the flight spectrum are indicated stagnation point convective and radiative (equilibrium) heating values encountered (1, 2, 3, 4). It is quite apparent from this that satellite environments experience considerably lower convective heating than ballistic environments -- an order of magnitude less, whereas probes re-entering at super-orbital velocity will initially experience heating rates of the satellite level (high altitude regime not shown) and upon penetration deep into the atmosphere, convective heating that can be equal to or exceed that of the ballistic vehicle. The radiative contribution to the heating at

the stagnation point for both the satellite and ICBM is essentially negligible; however probes at super-orbital velocities are exposed to considerable amounts. In fact, for some cases the radiative contribution can equal or exceed the convective input. (The determination of the precise radiation contribution at the higher velocities is complex due to the problem of non-equilibrium radiation).

It is apparent from the examination of these limited trajectory data that large variations in test parameters are necessary in order to conduct complete materials investigations over such a broad range of flight regimes. The same is true for a particular mission for here, too, the vehicle flow parameters can change by orders of magnitude over a trajectory. While it would be desirable to attain complete trajectory simulation from the onset of re-entry to impact for design material performance, meaningful studies in the case of ablation materials can be conducted at environmental conditions typical of different portions of the re-entry corridor. This approach has been very successful to date in the evaluation of thermal shield materials for current ballistic missile and satellite missions. As long as the local test conditions are well characterized even though they do not pertain to a specific trajectory, such work results in useful materials characterization.

In most ground based experimental investigations exact simulation even at a given trajectory point is not very practical within the economical scope of basic materials studies. One must therefore examine the environmental requirements to establish at least the minimum simulation necessary.

Since this paper is concerned only with the response of the outermost surface of a re-entry vehicle and not subsurface structure, this additional criterion is considered in establishing simulation minimums.

III. GROUND TEST REQUIREMENTS

From theoretical aerothermodynamic studies one observes that certain free flight parameters must be reproduced in any test environment if heat protection materials response appropriate to a specific environment is to be obtained. Since it governs the concentration of the various molecular and atomic gas species produced in the flow environment, thereby establishing the driving potential for the chemical interactions with a surface, the gas stagnation enthalpy is a key property that must be simulated. As we have seen, however, this parameter can vary from the very high values during the early phases of re-entry to fractions of those values as the various vehicles decelerate within the atmosphere. This suggests that besides the proper levels of gas enthalpy one must adjust test model pressure to match, at least order of magnitude-wise, the equivalent surface pressures experienced in flight at the particular enthalpy (or velocity) conditions of interest. The proper pressure environment is very important since it affects the rates of the chemical reactions occurring in the boundary layer and on the surface of the re-entry vehicle. To be assured that similar chemical reactions will occur at the surface of a test model, the appropriate gas species (air) must be generated in the test facility. This statement is not trivial but rather appropriate, the point being that the test environment must not contain extraneous species, gaseous or otherwise, that would tend

to modify true material performance. Although there are circumstances whereby this requirement can be relaxed somewhat depending upon the material being investigated, the main consideration here is that test programs must be conducted in the correct gas environment (air) such that the proper concentrations of oxidizing species are present for the combustion and pyrolysis reactions that would occur as the material interacts with the environment. Electric arc test facilities used in the past for materials investigations have been limited in their application to experimental studies because of the large percentage of foreign matter added to the high enthalpy flows which resulted in significant reductions of the available oxidizing species in the case of air.

Further examination of simulation requirements reveals that besides the gas state properties and chemistry, certain other aerodynamic flow criteria should be established. Consider, for example, an ablating thermal shield material which chars when subjected to re-entry heating. For such a material maximum thermal blockage results when the char remains on the surface re-radiating away a large portion of the heat input, and providing a relatively low thermally conductive path to the base material. The adhesive qualities of the chars formed in the ablation process varies greatly from one material to another so that depending upon the test environment some chars will break off from the base material while others will remain intact. Because of the large variations in air properties over the re-entry flight spectrum as shown in Figs. 1 and 2, equivalently broad ranges in the aerodynamic viscous forces will occur about a vehicle

throughout a trajectory. It is therefore desirable that materials investigated experimentally for application to specific missions should be exposed to environments in which the appropriate values of aerodynamic shear are produced on the test specimen. In general, the neglect of this aerodynamic criterion in the evaluation of any materials in which the outermost layers are degraded and continuously removed could result in ambiguous design information. There are additional parameters worthy of simulation; however, from the aerothermodynamic standpoint it would seem that the degree of flight simulation discussed should be sufficient for meaningful experimental materials investigations.

IV. ELECTRIC ARC HEATED TEST FACILITIES

Until recently there has been a lack of suitable test facilities, at least in the United States, for conducting experimental studies on materials that would yield properties and behavior in the types of re-entry environments that have been discussed. However with the need that has been generated by the ballistic missile programs, there have appeared new refinements of old techniques which hold promise for development into the necessary test facilities for the study of these material problems. In this respect, the emergence of the electric arc heater or plasma arc has been noteworthy. Essentially nothing more than a constrained electric arc struck between two electrodes such that electrical energy is imparted in the form of heat to the entrained gas, the plasma arc facility has reached a high level of development when compared to early designs. Not only have improved heater designs been built and operated successfully but

aerodynamic principles have been effectively incorporated resulting in improved test flow simulation. Current configurations can provide the required high enthalpy flows over a large range of test specimen pressures with air as the test medium and without any significant contaminant in the flow. Although still somewhat limited when it comes to the attainment of the extremely high enthalpies required for probe missions, the arc facilities through the manipulation of gas mass flow, arcing pressure, power input and degree of flow expansion are capable of simulating essentially the entire flight spectrum desired for materials investigations.

V. TEST PROGRAM

Although the discussion of the general requirements for test simulation for re-entry materials studies has been somewhat brief, it is sufficient for the scope of this paper; the remainder of the discussion will concern itself with a specific experimental investigation. As mentioned earlier, the purpose of the study was to determine the oxidation characteristics of a graphite material in a high stagnation enthalpy re-entry environment. Many types of graphites have been developed and are appropriate for a study of this type. The choice was made on the basis of current applicability to the aero-space field. The material selected was ATJ graphite, a fine grain commercial graphite produced by the National Carbon Company which has found application in rocket motor nozzle inserts. This material which is made by the pyrolysis of carbon base compounds has a density of about 1.73 grams/cc and a degree of anisotropy in mechanical and physical properties of less than two.

The test facility in which this investigation was conducted, the Hypersonic Arc Wind Tunnel of the G. E. Space Sciences Laboratory, is shown in Fig. 3. A close-up of an arc heater similar to that mounted on the wind tunnel is shown in Fig. 4 along with a schematic which can be used to describe its operation. Referring to that sketch, the large chambers on the left and right sides are the anode and cathode housings. The test fluid, which in this study was air, enters the chambers between the electrode housings and the plenum as indicated. Part of this gas passes into the electrode chambers, mixes with the carbon eroded from the electrodes and is exhausted from the heater along with the contaminant. The remainder of the gas which is free of contaminant is heated in the arc column, enters the plenum from both sides where mixing takes place and is then expanded through the sonic throat and conical nozzle to the test section. The nozzle whose included cone angle is $21\text{-}1/4^\circ$ can be shortened from its usual length ($4\text{-}7/8''$ exit diameter) to a point where the exit diameter is $1\text{-}3/16''$. Tests can be run at the above nozzle locations (geometric A/A^* values of 1000 and 58, respectively) and at intermediate area ratios by moving the model into the large nozzle. Models are usually downstream of the nozzle exit in what corresponds to a free jet flow. Immediately behind the model the test gas is collected in the entrance cone of the diffuser, passes through the diffuser proper which is simply a constant area section and then is exhausted through the two stage mechanical pumping system.

As is the case with any facility, test flow characterization is necessary before any meaningful analyses of the experimental data can be made. For a wind tunnel facility in which the test gas is generated by an electric

arc heater the calibration program is essentially two-fold. First, there is the determination of the state of the gas generated by the arc heater and, secondly, the evaluation of the modifications to this high temperature gas by the expansion nozzle. To establish the stagnation properties of arc heated gas, both spectroscopic and total calorimetric measurements were made. This is accomplished through the use of a special plenum unit which permits the simultaneous observation of the flow at the sonic throat with a spectrograph and the collection of the exiting gases in a water-cooled total calorimeter (see Fig. 5). From the spectral measurement one can determine a static temperature (from a ratio of the intensities of two atomic oxygen lines, $7949/7774 \text{ \AA}$ -- reference 5) and assuming flow equilibrium, along with the knowledge of gas pressure, values of stagnation enthalpy can be obtained from tabulated gas state properties. In the calorimetric experiment with the measured gas flow and the heat extracted from the gas, the total enthalpy can be computed. Measurements in various flows (T_s up to 8000° K) using the above techniques and appropriate interpretation have produced good correlations in stagnation enthalpy values. In analyzing this dual approach one observes that the spectral measurements at the throat favor the higher temperature regions of the flow while the calorimetric measurement will tend to produce a weighted average somewhat below that indicated by the former. There will also be some losses inherent with the calorimeter experiment; however with care these can be held to a minimum. Calculation of total enthalpy from emission spectroscopy measurements which respond to electronic excitation is only valid when thermodynamic and chemical

equilibrium exist in the flow. Conversely if the resulting values of enthalpy from these temperature measurements corroborate those from total calorimeter data one can conclude that the flow is in equilibrium.

Besides the determination of the total enthalpy of the generated gas it is important to establish the degree to which foreign contaminants have been added to the flow from the arc heater components (primarily electrode material). Spectrographic observations of the flow at the throat and in the plenum of the Tandem Gerdien arc heater configuration have indicated that the level of the primary contaminant -- carbon -- in the test gas is of the order of 100 ppm at stagnation enthalpy values (h_s/RT_0) up to 400. These conditions can be maintained throughout the test time which presently can be as much as 15 minutes. Although other trace elements are present, the amounts, which are considerably less than the carbon, are not expected to have any significant effects in materials investigations.

The second phase of the calibration procedure involves the characterization of the flow in the facility test section. To do this the nozzle flow was examined in some detail wherein static pressure distributions were obtained along the nozzle wall and impact pressure and heat transfer data were measured along the axis and across the flow at various nozzle stations. A photograph of typical diagnostic instrumentation is shown in Fig. 6. Results from these studies in conjunction with nozzle boundary layer calculations for equilibrium and constant specific heat ratio expansions were studied to arrive at some indications as to the flow properties

in the test section. A more detailed explanation of these investigations can be found in reference (6).

The material tests were performed with flat-faced cylindrical models. This choice was made for two reasons -- because (1) the gradient of heat transfer rate at the stagnation point is low (much lower than a hemisphere) thus minimizing three-dimensional effects in that region of interest and (2) such models produced no significant shape change throughout a typical test. Since it was desirable to evaluate the material performance over a large surface temperature range the models were fabricated using two different modes of construction. In the one case for test data at the lower temperatures the entire model was made of graphite with a 1/4" diameter graphite insert placed at the stagnation point. For the data at the higher temperatures a flat 3/4" diameter piece of graphite, 1/4" thick, was cemented with graphite cement into 1" cylindrical zirconia holders. In this manner the solid graphite models which did not heat up fast due to their high conductivity and large heat capacity provided sufficient time in which to obtain the necessary measurements at the lower temperatures where the mass transfer changes rapidly with temperature. On the other hand the other specimens embedded in the zirconia increased in temperature very rapidly and remained at the high temperatures for long times. In this manner data were obtained in both temperature regions. A photograph of typical models is shown in Fig. 7.

The experimental program was conducted at a nominal stagnation enthalpy (h_s/RT_0) of 400. Once the flow was characterized, the procedure was to insert the models into the flow and monitor the temperature of the model surface at the stagnation point with a recording optical pyrometer. Exposure of separate models for increasing test time permits one to obtain incremental changes in averaged mass loss rate at various temperature levels from the difference in mass loss between successive model tests. For example;

$$\dot{m}_w = \frac{\Delta \left(\frac{W}{A} \right)_2 - \Delta \left(\frac{W}{A} \right)_1}{t_2 - t_1} = \frac{\text{lb/ft}^2}{\text{sec.}}$$

is considered to represent the mass rate at:

$$\frac{T_{w2} - T_{w1}}{2} + T_{w1}$$

This procedure is acceptable as long as the variation of mass loss rate with surface temperature is a reasonably linear function of temperature and, as has been shown theoretically, this is the case in both the reaction rate and diffusion controlled zones. Surface pressure measurements at the model stagnation point were also obtained using water cooled probes.

VI. RESULTS AND DISCUSSION

Values of the experimental mass loss rates for ATJ graphite are shown in Fig. 8 as a function of surface temperature and pressure along with theoretical relationships of Scala (7) for the test environment. Using the two nozzle test flows mentioned previously these data were obtained essentially in a constant stagnation enthalpy environment of $400 RT_0$ at two values of model pressure (9.7×10^{-3} and 4.4×10^{-2} atm abs.). The curves represent what are considered to be typical bounding values for mass transfer from graphite in the range of wall temperature indicated; that is, the oxidation rate data used to calculate those relationships represent (according to Scala) typical graphite data for which sufficient variation in specific reactivity exists to produce a region bounded by the two curves. Examination of the test results in Fig. 8 shows in the lower pressure environment an aggregate of data points in the vicinity of 1200°K that lie within the bounds indicated for reaction rate controlled oxidation while increased mass rates are shown at higher temperatures that are beyond the curve labelled "slow" reaction rate. At the higher pressure test conditions the data, which are at temperatures of 2200°K , are again shown to be beyond the reaction rate zone and, as would be expected due to the more severe environment, indicate increased mass transfer over that experienced at the lower pressure. Although it was desirable to obtain data in the reaction rate controlled temperature regime at this test condition also, the very rapid rise in temperature of the test model prevented meaningful measurements. The large scatter of the data in the

reaction rate zone is attributed to (a) the behavior of the graphite in this temperature range in which significant changes in mass loss rate occur with small changes in surface temperature and (b) to the accuracy of the surface temperature measurement ($\pm 50^{\circ}\text{K}$). It is interesting to observe that ATJ graphite appears to oxidize somewhat more characteristic of the slower of the two reaction rate curves shown for typical graphites. This is a desirable feature since the greater the delay of the high mass rate to higher temperatures the better the over-all performance of such a material on a re-entry vehicle.

Data shown for both pressures at temperatures in excess of 1700°K does not appear to be rate controlled but rather diffusion controlled; that is, the combustion process is no longer governed by the rate of the reaction but rather by the rate with which the oxygen-bearing species get to the surface. To display this more clearly it is advantageous to use the correlation parameter $\dot{m}_w \sqrt{R_B/P_e}$, suggested by reference (7), since it is only a function of material surface temperature. The calculations of reference (7) were performed for a Newtonian pressure distribution and the experimental results in the current study were obtained on a flat faced body; therefore it is necessary to modify the results for the appropriate pressure distribution. Referring to the work of Boison and Curtiss (8) in which velocity gradients were investigated for various blunt bodies, the experimental data were interpreted in terms of the Newtonian flow field. These are shown in Fig. 9 in the form of the correlation parameter along with the theory of reference (7). The dotted curves

represent the reaction rate controlled regime as previously described and the solid line represents Scala's value for diffusion controlled oxidation. Whereas the mass rate data in Fig. 8 are shown essentially in three different zones, in Fig. 9 these have been reduced to two zones which correspond with the reaction rate controlled and diffusion controlled regimes as represented by Scala.

In the diffusion controlled regime the experimental data follow the general trend of the theoretical prediction but indicate on the average a twenty percent increase in mass loss. This is not an excessive deviation nor is it unreasonable in materials investigations of this type. One source of the discrepancy might be continued oxidation after tests while the models cooled down, even though both power and gas flow to the facility were stopped immediately and the models were left in the evacuated tunnel with the pumps running. However it is difficult to expect any appreciable oxidation under these circumstances as model surface temperature decreased rapidly in a very short period of time. On the other hand, an examination of the theory shows that skin friction relationships used in the determination of the mass transfer apply to high Reynolds number environments; yet for these tests Reynolds numbers based on model diameter were less than 1000. Under these conditions increased skin friction would result along with an increase in mass transfer.

In the reaction rate regime the scatter in the data prevents a positive definition of oxidation performance and merely serves to indicate that ATJ oxidation in that temperature zone lies between the two

extremes shown in Fig. 9. Additional experiments are required to establish more precisely that mass rate-temperature variation, although from the present results mean values could be determined. Having such data one can establish rate controlled oxidation characteristics which, along with the diffusion controlled theory, fully characterizes material performance.

At the beginning of the paper it was argued that ground-test simulation requires the reproduction of test properties peculiar to the particular regimes of interest on the trajectory map. For the tests conducted in this investigation the environment simulated represents essentially orbital velocity in the vicinity of 240,000 to 270,000 feet altitude. While the data show good agreement with the theory in these tests it is desirable to extend the test parameters over a wider range of trajectory variables to assure the universality of the theoretical relations. The main deviation in the oxidation characteristics however is expected to occur only in the transition region between the reaction rate and diffusion controlled zones as the pressure or altitude is varied. The basic diffusion controlled regime at temperatures beyond the transition area is independent of pressure level when presented in the form of the mass rate parameter shown in Fig. 9.

VII. CONCLUDING REMARKS

An experimental investigation was conducted to study the oxidation performance of ATJ graphite in dissociated air. To characterize the

behavior of such a material in a re-entry environment requires the proper simulation of certain free flight flow field parameters which greatly influence material performance. For good experimental simulation it is desirable to establish in the test facility at least the following: stagnation enthalpy of the gas stream, model pressure, flow chemistry and aerodynamic shear.

The stagnation enthalpy which also acts as the driving force for the heat transfer to the body is responsible for the production of the correct gas species in the flow; the level of pressure influences the chemical reactions between the boundary layer and the body surface; the chemistry of the flow is important because it must be that of the environment being simulated and free of extraneous species, and the shear force at the gas-surface interface which acts as an erosive force on the material must be reproduced to the correct order of magnitude if one is to apply test facility material performance to actual design hardware.

Arc heaters which are generally used for such materials evaluation can provide the necessary simulation.

Tests were conducted in a hypersonic arc wind tunnel in which the material mass loss was correlated as a function of model surface temperature. The data obtained indicated two specific zones of material performance, one in which the rate of the reaction between the oxygen species and the material govern the mass loss and the other in which the rate of diffusion of the oxygen-bearing species to the surface is dominant. . Comparison of these experimental data with the theory of Scala showed good agreement.

ACKNOWLEDGEMENT

The authors wish to acknowledge the capable assistance of their colleagues in the conduction of this investigation. To G. Catalano, W. Heard and J. Logan for conducting the experimental program, H. Sadjian and R. Harner for their help with the spectrographic analysis, Dr. J. McGinn for his counsel in the design and operation of the Tandem Gerdien arc heater and Dr. S. Scala for his thoughtful discussions, the authors are deeply indebted. Special thanks go to Dr. W. R. Warren for his guidance throughout the entire investigation.

REFERENCES

1. Scala, S. M. ; A Study of Hypersonic Ablation; Proceedings of the Tenth I. A. F. Congress, London, 1959; Springer Verlag.
2. Fay, J. A. , and Riddell, F. R. ; Stagnation Point Heat Transfer in Dissociated Air; Avco Res. Lab. , Res. Rept. 1, April, 1957.
3. Brunner, M. J. , and Gallagher, P. A. ; Analysis of the Aerodynamic Heating of a Blunt Hypersonic Glide Vehicle; G. E. MSVD TIS R58SD247, April, 1958.
4. Breene, R. G. , and Nardone, M. ; Radiant Emission from High Temperature Equilibrium Air; G. E. MSVD T. I. S. R61SD020, 1961.
5. Sadjian, H. , and Harner, R. S. ; G. E. MSVD Private Communication.
6. Warren, W. R. , and Diaconis, N. S. ; Air Arc Simulation of Hypersonic Environments; G. E. MSVD T. I. S. R62SD25, April, 1962; Presented Int'l Hypersonics Conf. M. I. T. , Cambridge, Mass. August 16-18, 1961.
7. Scala, S. M. ; The Ablation of Graphite in Dissociated Air; Part I, Theory; Present Nat'l Summer Mtg. , Inst. Aero/Space Sciences, Los Angeles, Calif. ; June 19-22, 1962.
8. Boison, J. C. , and Curtiss, H. A. ; An Experimental Investigation of Blunt Body Stagnation Point Velocity Gradient; ARS Journal, Vol. 29, No. 2, February, 1959.

RE-ENTRY HEAT TRANSFER

- Q_{CONV} (BTU/FT²-S)
- - - Q_{RAD} (BTU/FT²-S)
- $R_B = 1$ FT.

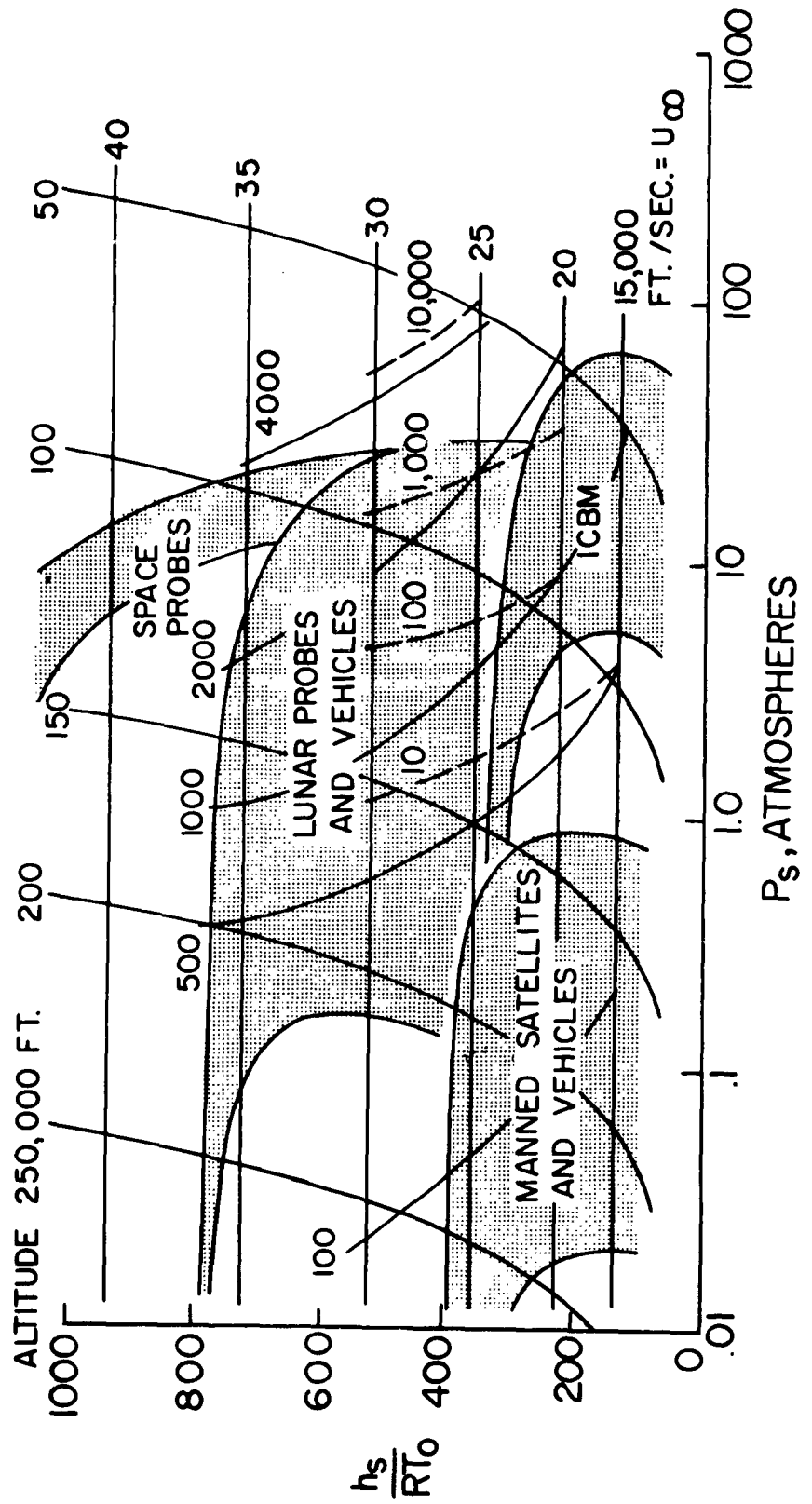

Figure 1

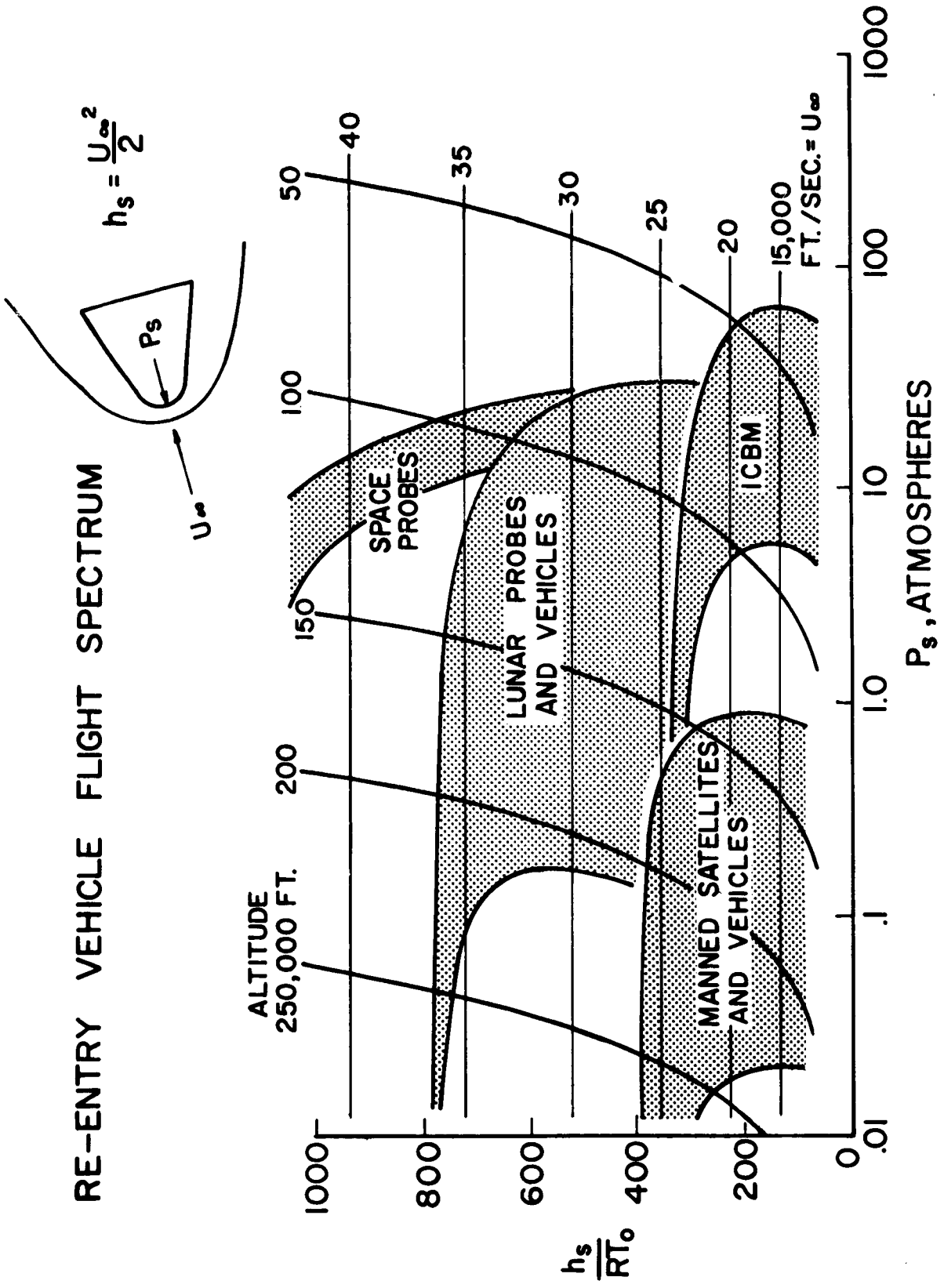

Figure 2

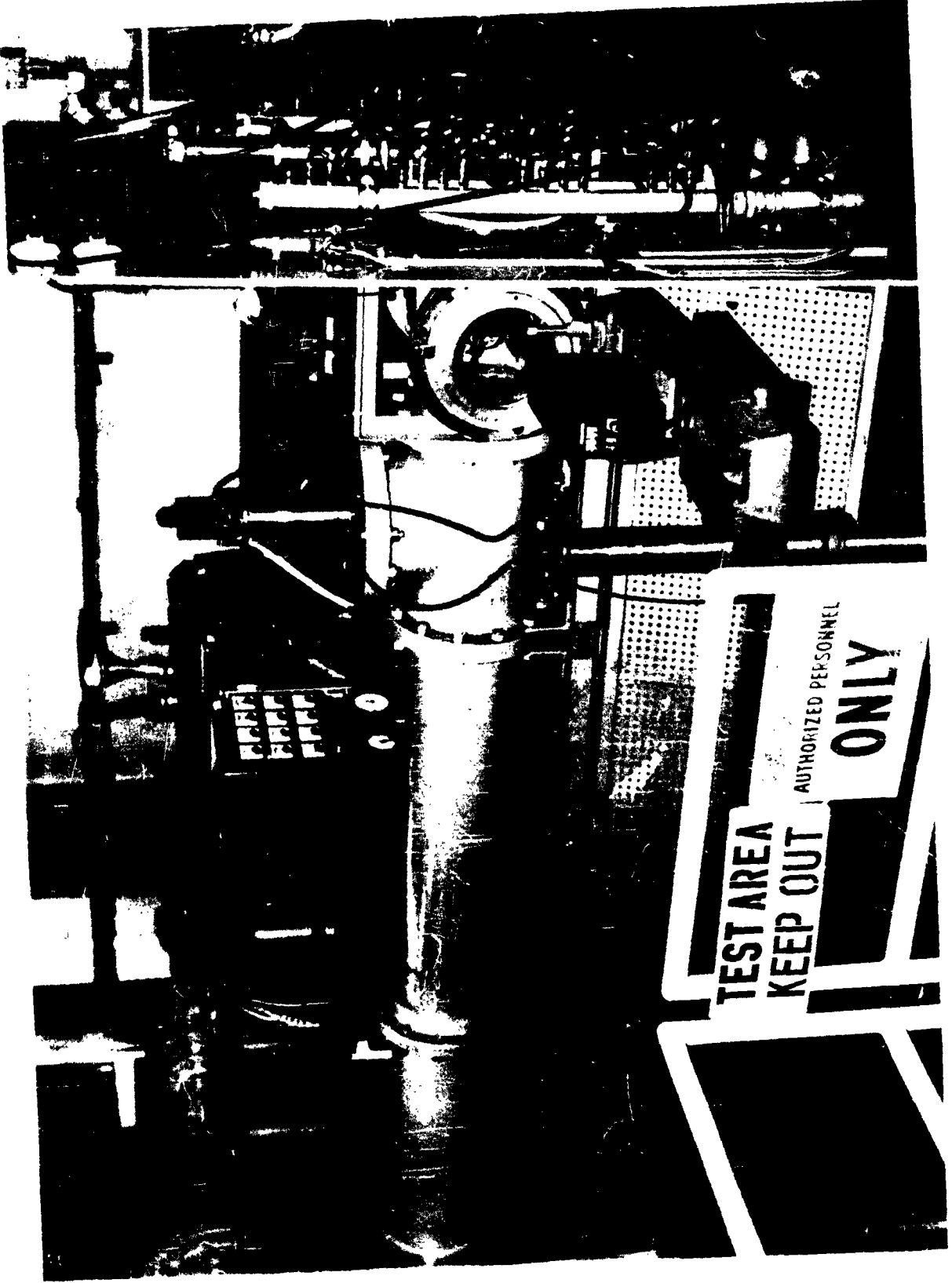
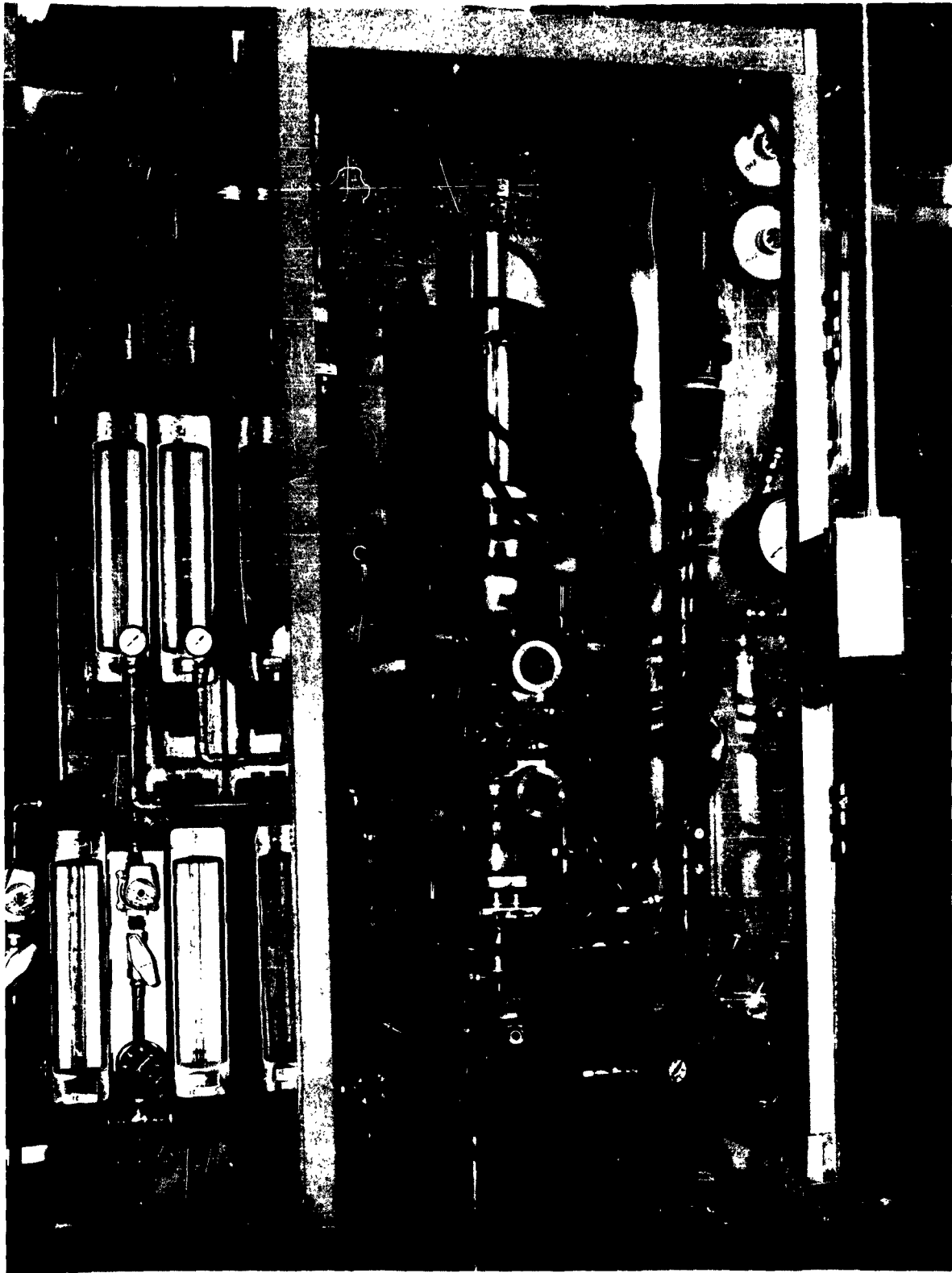

Figure 3 Hypersonic Air Wind Tunnel



Arc Heater - Hypersonic Wind Tunnel

Figure 4

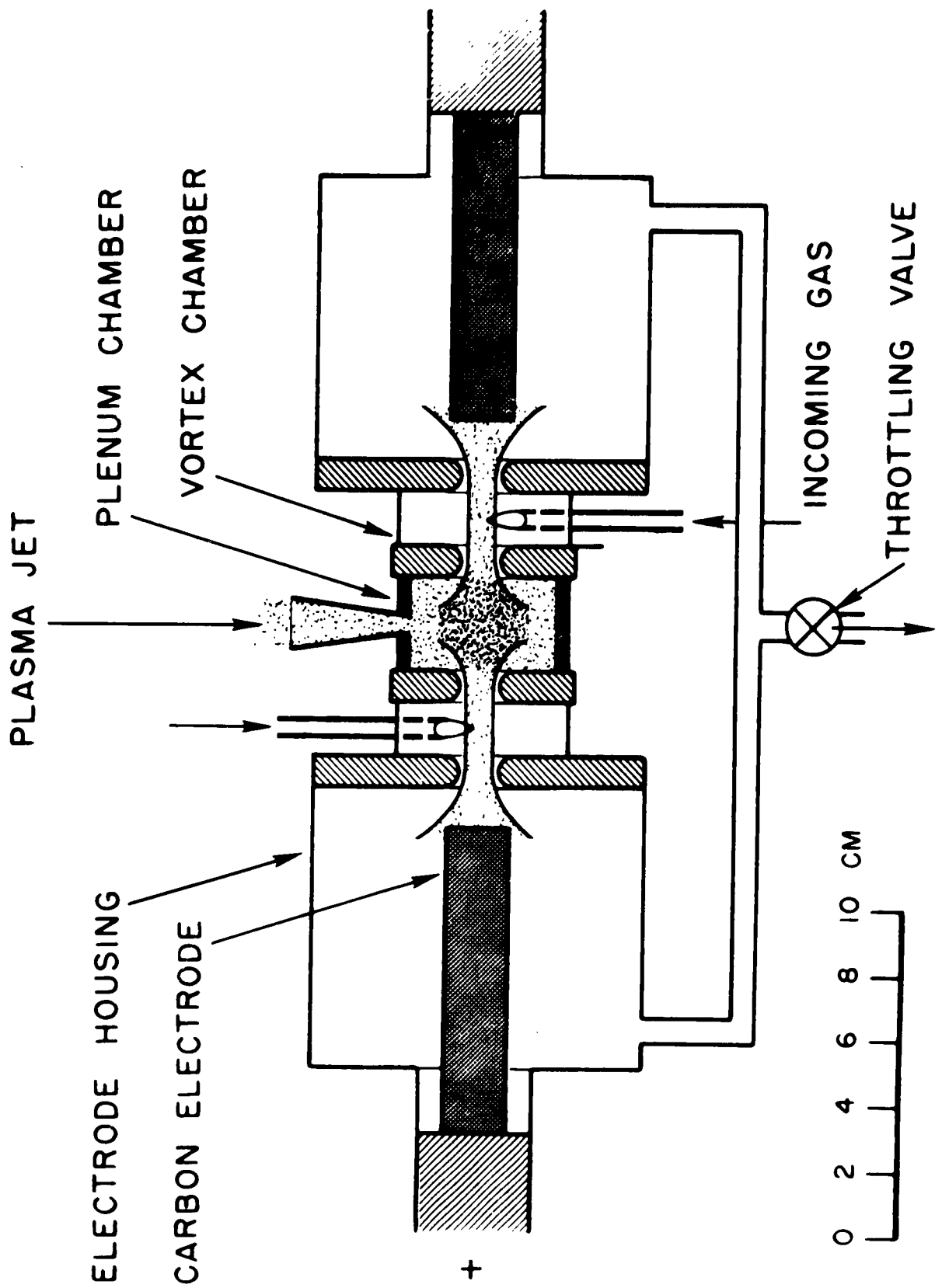

Figure 4a

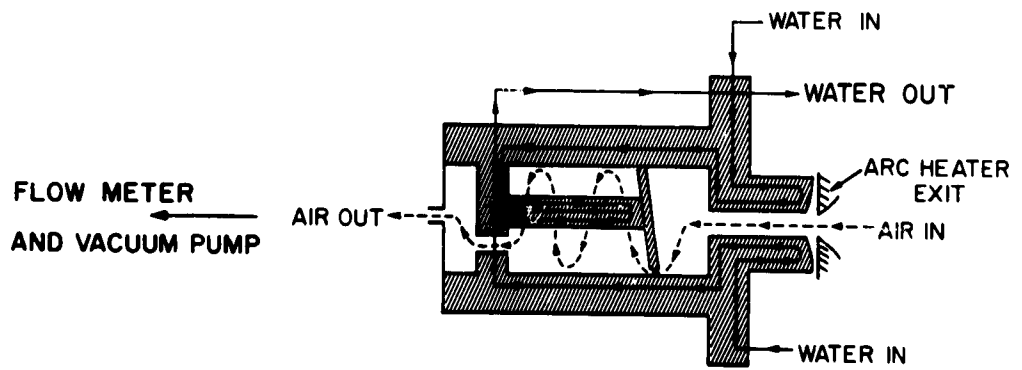
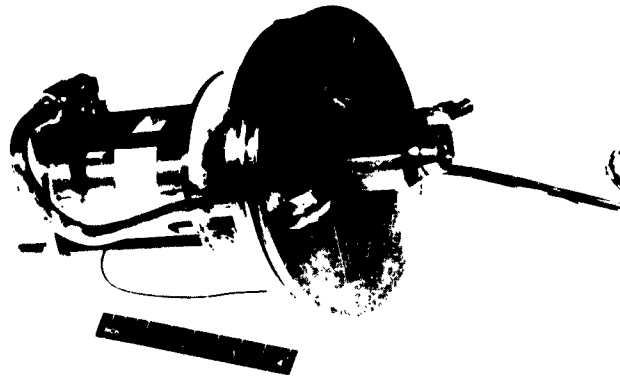

Figure 5 Total Enthalpy Calorimeter



H111111

ONE INCH

(a) Pressure Probe

(b) Model Calorimeter



(c) Heat Transfer Rake

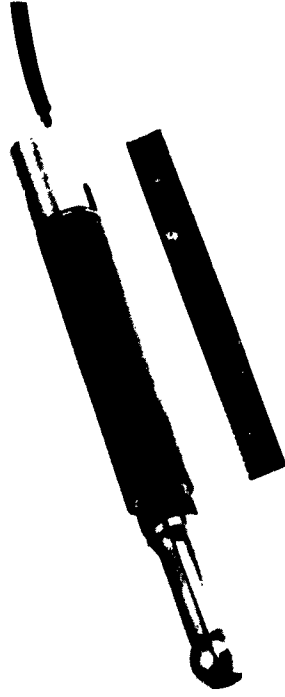

(d) Model Force Balance

Figure 6 Test Instrumentation



(A) MODEL CALORIMETER

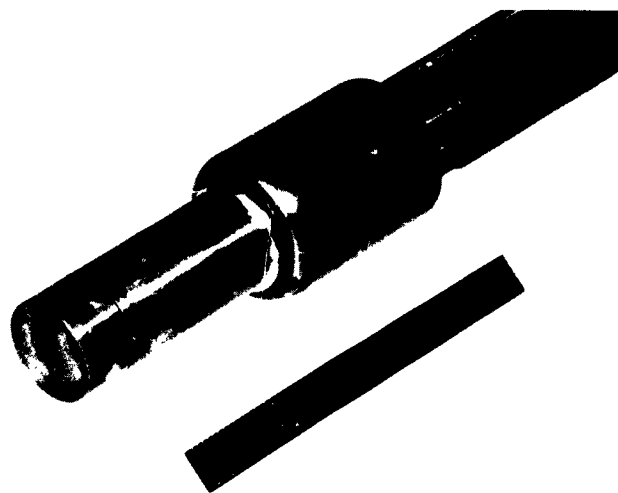

(B) MODEL PRESSURE



(C) TEST MODELS

Figure 7 Models for Graphite Test Program

VARIATION OF OXIDATION RATE WITH SURFACE TEMPERATURE AND PRESSURE

THEORY REF. (7), SCALA
 ----- REACTION CONTROLLED

ATJ GRAPHITE
 □ $P_e = .0443 \text{ ATM}$
 ○ $P_e = .0097 \text{ ATM}$
 $h_s/RT_0 \sim 400$

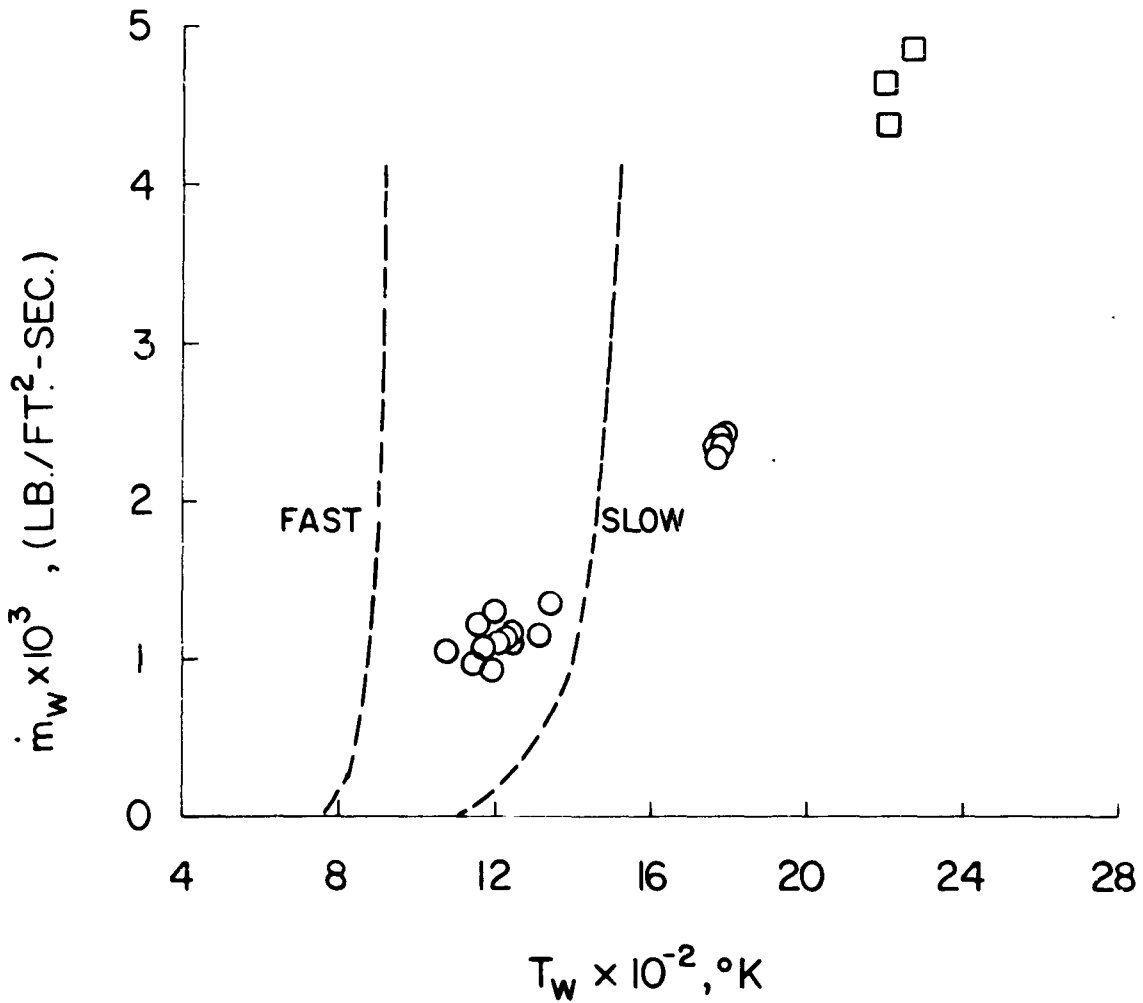

Figure 8

MASS TRANSFER FOR GRAPHITE COMBUSTION

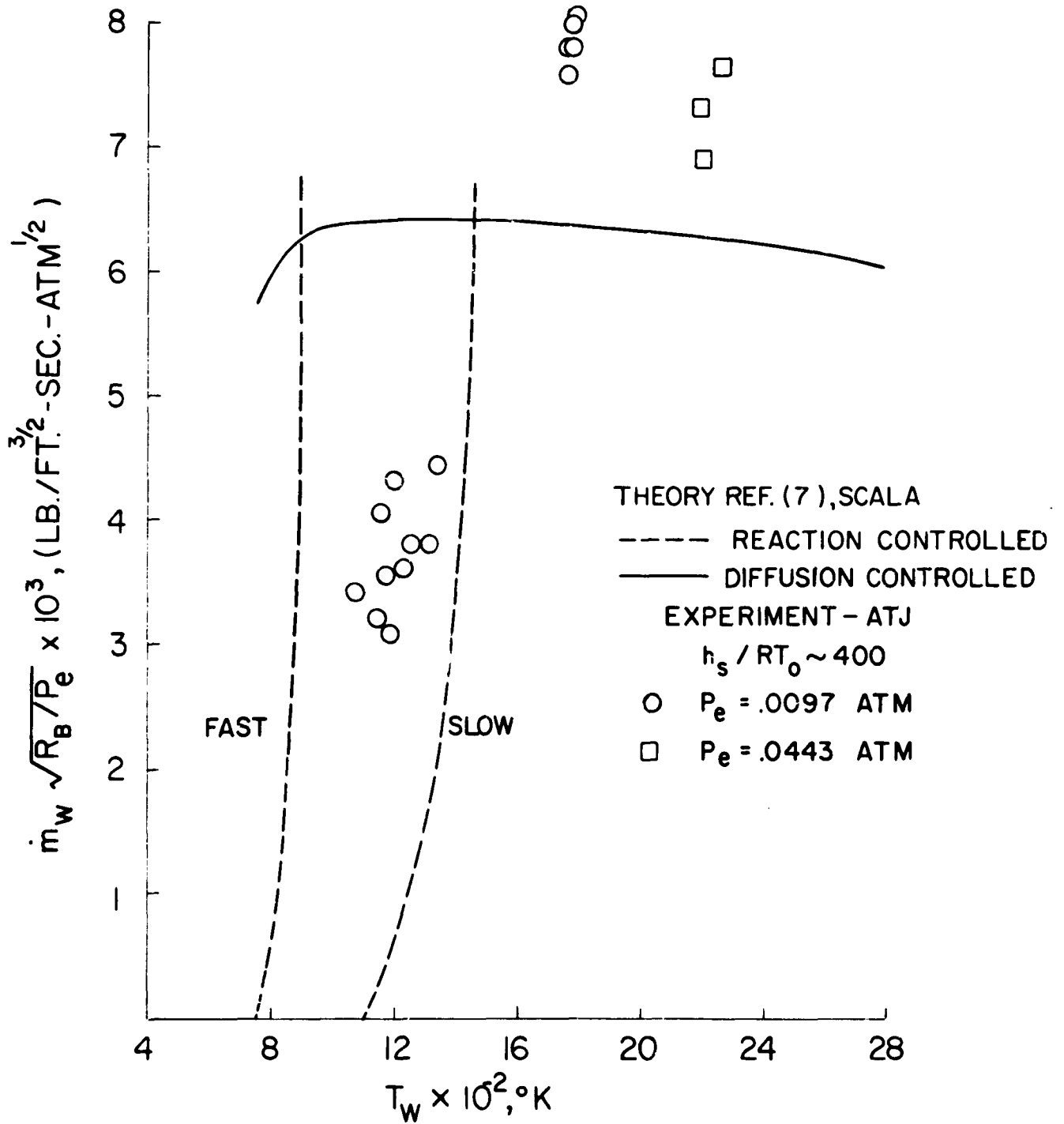

Figure 9

SPACE SCIENCES LABORATORY
MISSILE AND SPACE DIVISION

TECHNICAL INFORMATION SERIES

AUTHOR N. Diaconis P. Gorsuch R. Sheridan	SUBJECT CLASSIFICATION ABLATION	NO. R62SD86
		DATE Sept. 1962
TITLE The Ablation of Graphite in Dissociated Air. Part II: Experimental Investigation.		G. E. CLASS I
		GOV. CLASS Unclassified
REPRODUCIBLE COPY FILED AT MSD LIBRARY, DOCUMENTS LIBRARY UNIT, VALLEY FORGE SPACE TECHNOLOGY CENTER, KING OF PRUSSIA, PA.		NO. PAGES 32
SUMMARY An experimental investigation was conducted to study the oxidation performance of ATJ graphite in dissociated air. Tests were conducted in a hypersonic arc wind tunnel in which the material mass loss was correlated as a function of model surface temperature. The data obtained indicated two specific zones of material performance, one in which the rate of the reaction between the oxygen species and the material governs the mass loss and the other in which the rate of diffusion of the oxygen-bearing species to the surface is dominant. Comparison of these experimental data with the theory of Scala showed good agreement.		

By cutting out this rectangle and folding on the center line, the above information can be fitted into a standard card file.

<i>N. Diaconis</i>	<i>P. Gorsuch</i>	<i>R. Sheridan</i>
N. Diaconis	P. Gorsuch	R. Sheridan
AUTHOR		
<i>C. Mannal</i>	<i>L. McCreight</i>	
C. Mannal	L. McCreight	
COUNTERSIGNED		