

**UNCLASSIFIED**

---

---

**AD 291 407**

*Reproduced  
by the*

**ARMED SERVICES TECHNICAL INFORMATION AGENCY  
ARLINGTON HALL STATION  
ARLINGTON 12, VIRGINIA**



---

---

**UNCLASSIFIED**

NOTICE: When government or other drawings, specifications or other data are used for any purpose other than in connection with a definitely related government procurement operation, the U. S. Government thereby incurs no responsibility, nor any obligation whatsoever; and the fact that the Government may have formulated, furnished, or in any way supplied the said drawings, specifications, or other data is not to be regarded by implication or otherwise as in any manner licensing the holder or any other person or corporation, or conveying any rights or permission to manufacture, use or sell any patented invention that may in any way be related thereto.



291 407

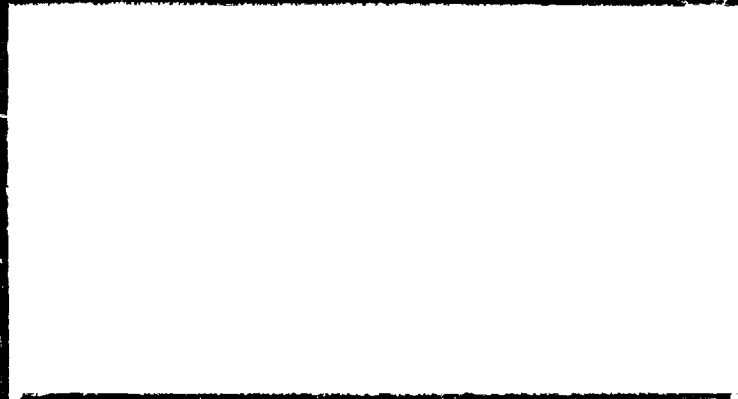

THE *M*arquardt  
CORPORATION

1 DECEMBER 1962

REPORT PR 281-20-3

COPY NO. 18

(TITLE -- UNCLASSIFIED)

MECHANICAL PROPERTIES OF  
COMMERCIALY PURE SINTERED TUNGSTEN ALLOY SHEET  
FROM ROOM TEMPERATURE TO 4500°F

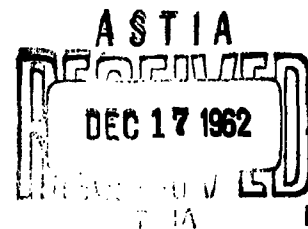

UNCLASSIFIED

(Title -- Unclassified)  
MECHANICAL PROPERTIES OF  
COMMERCIALY PURE SINTERED TUNGSTEN ALLOY SHEET  
FROM ROOM TEMPERATURE TO 4500° F

Contract AF 33(657)-8706

Project 281

PREPARED BY

*A. S. Rabensteine*  
A. S. Rabensteine

APPROVED BY

*M. J. Albom per AS*  
M. J. Albom  
Manager, Materials  
and Process Section

CHECKED BY

*J. W. Chambers per AS*  
J. W. Chambers  
Project Engineer

UNCLASSIFIED



YAN NUYS, CALIFORNIA

MAC A1758

CONTENTS

<u>Section</u>		<u>Page</u>
I	SUMMARY . . . . .	1
II	INTRODUCTION . . . . .	1
III	TEST MATERIALS . . . . .	1
IV	TEST PROCEDURES . . . . .	2
V	TENSILE AND CREEP-RUPTURE TESTS . . . . .	2
	A. Tensile Tests . . . . .	2
	B. Creep-Rupture Tests . . . . .	2
VI	BEND TRANSITION-TEMPERATURE TESTS . . . . .	3
VII	DISCUSSION . . . . .	3
	A. Tensile Properties . . . . .	3
	B. Creep-Rupture Properties . . . . .	4
	C. Bend Transition-Temperature Tests . . . . .	4
VIII	REFERENCES . . . . .	5
--	DISTRIBUTION . . . . .	36

MAC AGTS

TABLES

<u>Table</u>	<u>Page</u>
I. Process Information and Impurity Analysis for Commercially Pure Sintered Tungsten Sheet. . . . .	6
II. Tensile Properties for Commercially Pure Sintered Tungsten Sheet (0.020 inch) . . . . .	7
III. Tensile Properties for Commercially Pure Sintered Tungsten Sheet (0.045 inch) . . . . .	8
IV. Creep-Rupture Properties for Commercially Pure Sintered Tungsten Sheet (0.045 inch) at 2000°F . . . . .	9
V. Creep-Rupture Properties for Commercially Pure Sintered Tungsten Sheet (0.045 inch) at 2500°F . . . . .	10
VI. Creep-Rupture Properties for Commercially Pure Sintered Tungsten Sheet (0.045 inch) at 3000°F . . . . .	11
VII. Creep-Rupture Properties for Commercially Pure Sintered Tungsten Sheet (0.045 inch) at 3500°F . . . . .	12
VIII. Creep-Rupture Properties for Commercially Pure Sintered Tungsten Sheet (0.045 inch) at 4000°F . . . . .	13
IX. Creep-Rupture Properties for Commercially Pure Sintered Tungsten Sheet (0.045 inch) at 4500°F . . . . .	14
X. Creep-Rupture Properties for Commercially Pure Sintered Tungsten Sheet (0.020 inch) from 2000 to 3000°F . . . . .	15
XI. Creep-Rupture Properties for Commercially Pure Sintered Tungsten Sheet (0.020 inch) from 3500 to 4500°F . . . . .	16
XII. Bend Transition-Temperature Tests for Commercially Pure Sintered Tungsten Sheet . . . . .	17

MAC 4673

UNCLASSIFIED

ILLUSTRATIONS

<u>Figure</u>	<u>Page</u>
1. The Marquardt TM-1A Elevated Temperature Test Machine Test Specimen Configuration. . . . .	18
2. Test Specimen Configuration. . . . .	19
3. Tensile Properties of Commercially Pure Sintered Tungsten Sheet. . .	20
4. High Temperature Tensile Properties of Commercially Pure Sintered Tungsten Sheet . . . . .	21
5. Plastic Creep Properties of Commercially Pure Sintered Tungsten Sheet (0.045 inch) at 3000°F . . . . .	22
6. Plastic Creep Properties of Commercially Pure Sintered Tungsten Sheet (0.045 inch) at 3500°F . . . . .	23
7. Plastic Creep Properties of Commercially Pure Sintered Tungsten Sheet (0.045 inch) at 4000°F . . . . .	24
8. Plastic Creep Properties of Commercially Pure Sintered Tungsten Sheet (0.045 inch) at 4500°F . . . . .	25
9. Plastic Creep Properties of Commercially Pure Sintered Tungsten Sheet (0.020 inch) at 3000°F . . . . .	26
10. Plastic Creep Properties of Commercially Pure Sintered Tungsten Sheet (0.020 inch) at 3500°F . . . . .	27
11. Plastic Creep Properties of Commercially Pure Sintered Tungsten Sheet (0.020 inch) at 4000°F . . . . .	28
12. Plastic Creep Properties of Commercially Pure Sintered Tungsten Sheet (0.020 inch) at 4500°F . . . . .	29
13. Stress to Produce 1% Plastic Creep and Rupture in 10 Minutes of Commercially Pure Sintered Tungsten Sheet. . . . .	30
14. Microstructure of Commercially Pure Sintered Tungsten Sheet. . . . .	31
15. 0.2% Yield Strength-to-Density Ratio for Various Refractory Metals and Alloys . . . . .	32
16. Stress to Produce 1% Plastic Creep in 10 Minutes for Various Refractory Metal Sheet Alloys. . . . .	33
17. Stress to Produce Rupture in 10 Minutes for Various Refractory Metal Sheet Alloys . . . . .	34
18. Bend Transition - Temperature Properties for Commercially Pure Sintered Tungsten Sheet. . . . .	35

MAC AGTS

UNCLASSIFIED

UNCLASSIFIED

I. SUMMARY

Tensile properties of commercially pure sintered tungsten sheet are presented at test temperatures ranging from room temperature to 4500°F for 0.020-inch thick material and from 1500° to 4500°F for 0.045-inch thick material. Creep-rupture properties at temperatures ranging from 2000° to 4500°F for both the 0.020 and 0.045-inch thick material are included. Bend transition-temperature test data for 0.030-inch thick material are presented at temperatures ranging from 200° to 540°F using 1 T & 2 T radii.

Strain rate to YS = 0.001 in./in./sec

Strain rate from YS to UTS = 0.01 in./in./sec

Gage length = 1.0 inch

Material condition = Uncoated, as rolled, and stress relieved

Test atmosphere = Argon - 7% hydrogen

Test direction for tensile and creep-rupture tests = Longitudinal to rolling

Test direction for bend transition-temperature tests = Transverse to rolling

II. INTRODUCTION

Studies of advanced aerospace systems have established that refractory metal alloys must be employed in applications where uncooled metallic structures are required for operation at temperatures in excess of 2000°F. The molybdenum base alloys have been subjected to a more intense concentration of research effort than the other refractory metals and thus offer, at the present time, the greatest potential for near term applications, since they are the most readily available and several oxidation resistant coatings have been developed. However, each of the other refractory metals (i.e., columbium, tantalum, and tungsten) offer certain advantages over molybdenum alloys, but are presently limited in their usefulness in that there is a lack of satisfactory oxidation protective coatings and only very limited design data are available to adequately describe the performance of these materials under the conditions attendant to advanced systems. The work reported herein may offer some solution to the utilization of tungsten in certain aerospace applications by those engaged in aerospace research and development.

III. TEST MATERIALS

Several sheets of commercially pure sintered tungsten 0.020, 0.030, and 0.045-inch thick were obtained from the Fansteel Metallurgical Corporation for the elevated temperature tensile, creep-rupture, and bend-transition tests described in this report. Table I shows the process information, diamond hardness values, and interstitial gas contents for the 0.020 and 0.045-inch thick sheet. Hardness values and gas contents were not determined for the 0.030-inch sheet.

MAC AG32

UNCLASSIFIED

UNCLASSIFIED

IV. TEST PROCEDURES

All testing was conducted with the Marquardt TM-1A Elevated Temperature Test Machine (See Figure 1). Strain rates used were 0.001 in./in./sec to the yield strength and 0.01 in./in./sec to fracture. Specimen heating was accomplished by self-resistance for both the tensile and creep-rupture tests. Temperatures from room temperature to 3200°F were controlled and recorded by a calibrated platinum/platinum-13% rhodium thermocouples and a millivolt null type potentiometer. For temperatures in excess of 3200°F, calibrated tungsten/tungsten-26% rhenium thermocouples were used. The material was tested in the uncoated condition under a protective atmosphere of argon-7% hydrogen. A drying train was situated between the gas source and the test chamber for purposes of minimizing any residual moisture in the gas. In addition, calculations of load cell and ram friction were made to allow presentation of data with a high degree of accuracy. These friction effects were found to be particularly critical in the high temperature tests where the specimens were of small cross-sectional areas and required only small leads.

The tensile and creep-rupture test specimens were produced by Elox machining. The specimen configuration is illustrated in Figure 2.

V. TENSILE AND CREEP-RUPTURE TESTS

A. Tensile Tests

Elevated temperature tensile tests were conducted with 0.020 and 0.045 inch thick sheet from room temperature to 4500°F. The test results are presented in Tables II and III and Figures 3 and 4. These plots show the tensile properties from room temperature to 4500°F, and from 3000° to 4500°F, respectively.

Room temperature and 1000°F tensile data were not obtained for the 0.045-inch thick sheet due to premature fractures which occurred in the grip area of the specimens during testing. However, room temperature and 1000°F tensile data were obtained for the 0.020-inch thick sheet. Typical brittle stress-strain, (i.e., no plastic deformation) characteristics were evident at room temperature for both sheet thicknesses.

B. Creep-Rupture Tests

The creep-rupture properties for 0.020 and 0.045-inch thick tungsten sheet were obtained over a temperature range of 2000° to 4500°F for a 30 minute maximum time. The test results are shown in Tables IV through IX for the 0.045-inch thick sheet and Tables X and XI for the 0.020-inch thick sheet. Graphical representations of the test data from 3000° to 4500°F are shown in Figures 5 through 8 for the 0.045-inch thick sheet and Figures 9 through 12 for the 0.020-inch thick sheet. A comparison of 1 percent plastic creep and rupture on a stress versus temperature basis is presented in Figure 13.

MAC 4678

UNCLASSIFIED

In order to obtain short time plastic creep and rupture values, the stresses employed were above the 0.2% yield stress and at times approached ultimate strength values. As a result, high values of strain occurred during loading. Where stresses were below the elastic limit of the material at each temperature, low values of loading extension were obtained which were accompanied by relatively slow rates of plastic creep. In this way, the creep-rupture properties were obtained for times ranging from a few seconds to 30 minutes.

VI. BEND TRANSITION-TEMPERATURE TESTS

Bend transition temperature tests were performed using 0.030-inch thick tungsten specimens cut transverse to the rolling direction. The specimens were abrasively sectioned from the sheet material to a size of 1/2 inch wide and 2 inches long. Bend radii of one and 2X material thickness were used in the tests (i.e., 1T and 2T). The results of these tests are shown in Table XII.

VII. DISCUSSION

A. Tensile Properties

Variations in the tensile behavior for the two sheet thicknesses tested in this program clearly indicate the effects of strain hardening (cold work) on tungsten tensile transition temperature. Hot-cold working is known to reduce the relatively high tensile and bend-transition temperatures of tungsten in addition to increasing its strength properties. Grain size has a significant effect on the ductile to brittle transition characteristics of tungsten (Reference 1) and is dependent on the amount of cold work given to an individual piece of tungsten sheet (Figure 3). Mention should also be made here of the effects of surface condition on the ambient temperature properties of tungsten sheet. For instance, a relatively rough surface, and in some cases surface imperfections at the microscopic level contribute significantly to brittle behavior and/or reduced tensile properties at room temperature.

The tensile properties for 0.020- and 0.045-inch thick tungsten sheet are compared in Figure 3 for temperatures up to 4500°F. The difference in strength properties reflects the susceptibility of tungsten to strain hardening. The elongation characteristics exhibit a sharp increase at approximately 2600°F for the 0.020-inch thick sheet, and approximately 2800°F for the 0.045-inch thick sheet. This sharp increase in elongation is attributed to recrystallization. These test results represent a classic example of the effects of strain hardening on recrystallization temperature. That is, a lower recrystallization temperature results as the amount of cold work is increased. This effect on microstructure can also be seen in Figure 14. Complete recrystallization occurred at 2750°F after a 5 minute exposure for the 0.020-inch thick specimens whereas the 0.045-inch thick sheet only partially recrystallized. Figure 4 depicts the high temperature strength properties for the 0.020 and 0.045-inch thick sheet. Ultimate strengths are within experimental scatter while the yield strengths show variations up to approximately 3500°F.

MAC AGZ

UNCLASSIFIED

B. Creep Rupture Properties

Creep behavior followed a normal pattern for most of the tests. However, the 2500°F tests for the 0.045-inch thick sheet exhibited anomalous creep. Similar results in the temperature range of 2500° to 2700°F have been reported by other sources (Reference 1). The reasons for anomalous creep can be attributed to several sources:

1. Recovery and partial recrystallization of the specimens during the tests
2. Minute amounts of porosity located at the grain boundaries, usually associated with powder metallurgy material
3. The effects of impurities on mechanical and recrystallization behavior (References 1 and 2)
4. Variation in consolidation practice in sintering (Reference 1)

No abnormal creep behavior was observed with the 0.020 inch thick sheet at 2500°F (See Table X).

Comparisons of the creep-rupture properties for the 0.020- and 0.045-inch thick tungsten sheet (See Figure 13) showed that the thinner sheet is superior. This is attributable, at least in part, to a larger grain size which resulted from earlier recrystallization of the 0.020-inch thick sheet and subsequent grain growth. A comparison of yield strength-to-density ratio and the creep-rupture properties for tungsten with the properties of the other refractory metals is shown in Figures 15 through 17. The superiority of tungsten sheet at high temperatures is clearly demonstrated.

C. Bend Transition-Temperature Tests

It can be seen from the results shown in Table XII that a 180° bend was produced over a minimum bend radius of 2 T at temperatures above 400°F. All specimens bent over a 1 T radius fractured prior to reaching a full 180° bend, at temperatures up to 540°F. A graphical representation of the bend data is given in Figure 18.

VIII. REFERENCES

1. Universal Cyclops Steel Corporation Report 7-827 (I), "Tungsten Sheet Rolling Program", dated December 1960.
2. Defense Metals Information Report No. 127, "Physical and Mechanical Properties of Tungsten and Tungsten Base Alloys", dated March 1960.

MAC AXE

UNCLASSIFIED

UNCLASSIFIED

ACKNOWLEDGEMENTS

The work reported herein was performed in the Materials and Process Laboratory of The Marquardt Corporation at Van Nuys, California. The contributions of R. D. Lloyd, A. Bennett, C. A. Drury, and A. Marderian to this report are acknowledged.

MAC 1A72

UNCLASSIFIED

TABLE I

PROCESS INFORMATION AND IMPURITY ANALYSIS  
FOR COMMERCIALY PURE SINTERED TUNGSTEN SHEET

Supplier	Heat Treat Condition	Sheet Thickness (in.)	DPH Hardness	Interstitial Gas Content in ppm		
				O <sub>2</sub> *	H <sub>2</sub> *	N <sub>2</sub> **
Fansteel Metallurgical	Stress Relieved	0.045	468	10	0.8	14
Fansteel Metallurgical	Stress Relieved	0.030	--	--	--	--
Fansteel Metallurgical	Stress Relieved	0.020	503	20	1.0	30

\* Vacuum fusion analysis

\*\* Kjeldahl analysis

MAC 4673

TABLE II  
 TENSILE PROPERTIES FOR  
 COMMERCIALLY PURE SINTERED TUNGSTEN SHEET (0.020 inch)

Test Conditions:

Machine	= ETIM	Atmosphere	= Argon-7% Hydrogen
Method of heating	= Resistance	Gage length	= 1.0 in.
Hold time at temperature	= 5 min.	Sheet thickness	= 0.020 in.
Strain rate to YS	= 0.001 in./in./sec	Material	= Uncoated, as-rolled, and stress relieved
Strain rate from YS to UTS	= 0.01 in./in./sec	Specimens	= Longitudinal

Specimen Number	Test Temperature (°F)	Prop. Limit (Ksi)	0.2% Yield Strength (Ksi)	Ultimate Tensile Strength (Ksi)	Elongation in 1.0 in. (%)	Modulus of Elasticity (x 10 <sup>6</sup> psi)
74F	RT	--	--	185.0	--	49.0
75F	RT	--	--	202.0	--	47.0
76F	RT	--	--	236.0	--	51.8
77F	1000	70.0	127.0	146.0	2.5	37.0
78F	1000	73.0	124.0	142.0	2.5	36.0
79F	1500	70.5	119.0	135.0	3.0	34.0
80F	1500	68.0	115.0	129.0	3.0	35.0
81F	2000	54.0	91.0	105.0	4.0	31.8
82F	2000	58.0	93.8	108.0	4.5	34.0
83F	2500	26.0	51.9	53.5	4.0	28.0
84F	2500	35.0	56.8	58.0	4.5	26.0
85F	2750	--	12.0	23.3	14.0	--
85	2750	--	14.8	23.9	15.0	--
86F	2750	--	36.7	38.5	5.0	--
86	2750	--	24.8	31.5	8.0	--
87F	3000	00	16.1	24.5	12.5	--
88F	3000	--	12.1	24.0	15.0	--
89F	3200	--	9.3	16.8	18.0	--
90F	3200	--	11.8	19.3	14.0	--
512F	3500	4.0	7.1	13.0	14.0	9.0
513F	3500	5.1	8.3	14.4	13.0	8.0
514F	4000	--	7.8	11.0	16.0	--
515F	4000	4.4	7.0	10.6	14.0	--
516F	4000	4.9	7.6	11.6	14.0	--
517F	4500	--	4.6	6.6	10.0	--
518F	4500	--	4.9	7.4	12.0	--
519F	4500	--	6.2	9.0	11.0	--

Reference: MPM 20.181

MAC 4673

TABLE III

 TENSILE PROPERTIES FOR  
 COMMERCIALLY PURE SINTERED TUNGSTEN SHEET (0.045 inch)
Test Conditions:

Machine = ETIM  
 Method of heating = Resistance  
 Hold time at temperature = 5 min  
 Strain rate to YS = 0.001 in./in./sec  
 Strain rate from YS to UTS = 0.01 in./in./sec  
 Atmosphere = Argon-7% Hydrogen  
 Gage length = 1.0 in.  
 Sheet thickness = 0.045 in.  
 Material = Uncoated, as-rolled, and stress relieved  
 Specimens = Longitudinal

Specimen Number	Test Temperature (°F)	Prop. Limit (Ksi)	0.2% Yield Strength (Ksi)	Ultimate Tensile Strength (Ksi)	Elongation in 1.0 in. (%)	Modulus of Elasticity (x 10 <sup>6</sup> psi)
340D	1500	39.0	72.0	85.5	3.5	48.0
341D	2000	42.0	69.2	78.0	6.0	41.0
342D	2000	39.0	62.0	72.1	5.5	36.5
344D	2500	33.0	42.7	49.0	8.0	29.5
345D	2750	9.0	18.9	28.7	11.0	20.0
346D	2750	20.0	31.0	34.8	8.0	24.0
347D	3000	5.0	10.8	24.0	16.0	15.0
348D	3000	5.3	9.8	21.8	18.0	16.0
349D	3200	--	9.3	19.4	13.5	13.3
350D	3200	3.0	7.6	18.8	20.0	15.4
520F	3500	--	9.2	15.7	15.0	--
521F	3500	5.9	8.5	14.6	15.0	7.0
523F	4000	4.8	6.5	10.8	13.0	--
524F	4000	5.1	6.2	10.9	14.0	--
526F	4500	--	4.2	5.4	7.0	--
527F	4500	--	5.2	7.6	9.0	--
528F	4500	--	4.2	6.3	11.0	--

Reference: MPM 20.181

MAC 467

CREEP-RUPTURE PROPERTIES FOR COMMERCIALY PURE SINTERED TUNGSTEN SHEET (0.045 inch) AT 2000°F

TABLE IV

Test Conditions:

- Machine = EMM
- Method of heating = Resistance
- Atmosphere = Argon - 7% Hydrogen
- Gage length = 1.0 in.
- Material = Uncoated, as-rolled and stress relieved
- Sheet thickness = 0.045 in.
- Specimens = Longitudinal

Spec. No.	Stress (Ksi)	Approx. Thermal Exp. (in.)	Loading Strain (%)	Time (seconds) to produce Indicated Plastic Creep						Plastic Creep in 900 sec (%)	Time to Rupture (sec)	Elong. (%)	Residual UTS (Ksi)
				0.05%	0.2%	0.5%	1%	2%	4%				
603D	57	0.00024	0.14	1.1	20	241	680	840	844	--	845	5.0	--
602D	50	0.00024	0.12	6.8	225	--	--	--	--	0.46	--	6.0	67.9
600D	40	0.00024	0.10	25	--	--	--	--	--	0.19	--	5.0	70.0

Reference: MPM 20.180

TABLE V

CREEP-RUPTURE PROPERTIES FOR COMMERCIALY PURE  
SINTERED TUNGSTEN SHEET (0.045 inch) AT 2500°F

Test Conditions:

Machine = ETM  
 Method of heating = Resistance  
 Gage length = 1.0 in.  
 Atmosphere = Argon-7% Hydrogen  
 Sheet thickness = 0.045 in.  
 Material = Uncoated, as-rolled,  
 and stress relieved  
 Specimens = Longitudinal

Spec. No.	Stress (Ksi)	Approx. Thermal Exp. (in.)	Loading Strain (%)	Time (seconds) to Produce Indicated Plastic Creep					Time to Rupture (sec)	Elong. (%)
				0.05%	0.2%	0.5%	1.0%	2.0%		
608D	45	0.0032	0.15	7	54	131	160	178	180	6.0
607D	41	0.0032	0.25	--	--	--	--	--	2	9.0
606D	41	0.0032	0.20	3.5	23	39	57	64	76	5.5
605D	37	0.0032	0.20	--	--	--	--	--	2	6.0
604D	34	0.0032	0.10	0.3	1.2	5.0	8.6	10	14	7.5

Reference: MPM 20.180

MAC A67

TABLE VI  
CREEP-RUPTURE PROPERTIES FOR COMMERCIALY PURE SINTERED TUNGSTEN SHEET (0.045 inch) AT 3000°F

Test Conditions:

- Machine = EITM
- Method of heating = Resistance
- Gage length = 1.0 in.
- Sheet thickness = 0.045 in.
- Atmosphere = Argon - 7% Hydrogen
- Material = Uncoated, as-rolled, and stress relieved
- Specimens = Longitudinal

Spec. No.	Stress (Ksi)	Approx. Thermal Exp. (in.)	Loading Strain (%)	Time (seconds) to Produce Indicated Plastic Creep							Plastic Creep in 1800 sec (%)	Elong. (%)	Residual UTS (Ksi)
				0.05%	0.2%	0.5%	1.0%	2.0%	4.0%	6.0%			
611D	13	0.0075	0.7	1.5	10	45	80	175	410	662	--	20	18.3
610D	11	0.0075	0.6	10	56	72	140	318	685	961	--	20	17.4
612D	9	0.0075	0.2	14	100	335	810	1537	--	--	2.2	20	17.5
609D	6	0.0075	0.18	22	205	544	1435	--	--	--	1.1	20	20.9

Reference: MPM 20.180

**TABLE VII**  
**CREEP-RUPTURE PROPERTIES FOR COMMERCIALLY PURE SINTERED TUNGSTEN SHEET (0.045 inch) AT 3500°F**

Test Conditions:

- Machine = EFTM
- Method of heating = Resistance
- Gage length = 1.0 in.
- Sheet thickness = 0.045 in.
- Atmosphere = Argon-7% Hydrogen
- Material = Uncoated, as-rolled, and stress relieved
- Specimens = Longitudinal

Spec. No.	Stress (Ksi)	Approx. Thermal Exp. (in.)	Loading Strain (%)	Time (seconds) to Produce Indicated Plastic Creep								Plastic Creep in 1800 sec (%)	Time to Rupture (sec)	Elong. (%)	Residual UTS (Ksi)
				Time (seconds) to Produce Indicated Plastic Creep											
				0.05%	0.2%	0.5%	1%	2%	4%	6%	8%				
558F	13	0.008	1.3	--	0.5	1.0	1.8	4.2	13	26	31	--	35	12	--
560F	11	0.008	0.5	0.2	0.6	1.2	10	40	110	150	155	--	158	9.5	--
561F	9	0.008	0.2	14	80	180	390	560	842	938	943	--	946	9	--
562F	9	0.008	0.5	1.1	25	91	227	320	330	--	--	--	347	8	--
563F	7	0.008	0.1	42	105	345	720	1105	1560	--	--	--	1590	6	--
565F	5	0.008	--	330	--	--	--	--	--	--	--	0.19	--	13.5	15.5

MAC A63

UNCLASSIFIED

TABLE VIII

CREEP-RUPTURE PROPERTIES FOR COMMERCIALY PURE SINTERED TUNGSTEN SHEET (0.045 inch) AT 4000°F

Test Conditions:

Machine = FMM  
 Method of heating = Resistance  
 Gage length = 1.0 in.  
 Sheet thickness = 0.045 in.  
 Atmosphere = Argon-7% Hydrogen  
 Material = Uncoated, as-rolled,  
 and stress relieved  
 Specimens = Longitudinal

Spec. No.	Stress (Ksi)	Approx. Thermal Exp. (in.)	Loading Strain (%)	Time (seconds) to Produce Indicated Plastic Creep										Plastic Creep in 1800 sec (%)	Time to Rupture (sec)	Elong. (%)	Residual UTS (Ksi)
				Indicated Plastic Creep													
				0.05%	0.2%	0.5%	1.0%	2.0%	4.0%	6.0%	8.0%	10.0%					
566F	11	0.0095	1.4	--	--	0.2	0.8	2.4	5.0	8.6	11	12	--	14	16	--	
567F	11	0.0095	1.7	--	--	--	0.2	1.5	2.5	4.0	5	6	--	8	15	--	
574F	9	0.0095	0.8	0.1	0.9	1.7	3.2	7.0	17	22	23	24	--	25	13	--	
569F	7	0.0095	0.4	0.4	5.0	17	45	67	78	81	--	--	--	83	8	--	
570F	7	0.0095	0.3	0.3	4.0	18	38	70	100	104	106	--	107	10	--		
580F	5	0.0095	0.07	20	107	270	695	1056	--	--	--	--	1250	--	--		
575F	3	0.0095	--	705	--	--	--	--	--	--	--	--	--	--	14	11.4	

MAC A37

UNCLASSIFIED

**TABLE IX**  
CREEP-RUPTURE PROPERTIES FOR COMMERCIALY PURE SINTERED SHEET (0.045 inch) AT 4500°F

Test Conditions:

- Machine = EFTM
- Method of heating = Resistance
- Gage length = 1.0 in.
- Sheet thickness = 0.045 in.
- Atmosphere = Argon - 7% Hydrogen
- Material = Uncoated, as-rolled,  
and stress relieved
- Specimens = Longitudinal

Spec. No.	Stress (Ksi)	Approx. Thermal Exp. (in.)	Loading Strain (%)	Time (seconds) to Produce Indicated Plastic Creep										Plastic Creep in 1800 sec (%)	Time to Rupture (sec)	Elong. (%)	Residual UTS (Ksi)
				0.05%	0.2%	0.5%	1.0%	2.0%	4.0%	6.0%	8.0%	10.0%					
583F	7	0.012	2.4	--	0.2	0.7	1.3	4.0	6.0	7.5	10	11	--	13	15	--	
573F	6	0.012	0.8	1.4	6.3	9.0	15	25	46	57	--	--	--	62	80	--	
576F	6	0.012	0.8	1.1	3.0	5.0	12	20	37	52	68	--	--	92	9.5	--	
577F	5	0.012	0.2	5.0	35	70	142	180	187	195	--	--	--	197	8	--	
578F	5	0.012	1.0	2.0	10	24	35	51	63	69	70	--	--	72	10	--	
582F	5	0.012	1.0	1.7	3.0	7.5	18	36	52	65	68	70	--	77	12.5	--	
579F	4	0.012	0.14	42	120	195	335	482	540	550	--	--	--	556	7.5	--	
581F	3	0.012	0.04	103	336	852	--	--	--	--	--	--	0.95	--	13	6.6	

MAC A673

TABLE X

CREEP-RUPTURE PROPERTIES FOR COMMERCIALY PURE SINTERED TUNGSTEN SHEET (0.020 inch) FROM 2000°F to 3000°F

Test Conditions

- Machine = FTIM
- Method of heating = Resistance
- Gage length = 1.0 in.
- Sheet thickness = 0.020 in.
- Atmosphere = Argon - 7% Hydrogen
- Material = Uncoated, as-rolled and stress relieved
- Specimens = Longitudinal

Spec. No.	Test Temp. (°F)	Stress (Ksi)	Approx. Thermal Exp. (in.)	Loading Strain (%)	Time (seconds) to Produce Indicated Plastic Creep							Plastic Creep in 1800 sec (%)	Time to Rupture (sec)	Elong. (%)	Residual UTS (Ksi)
					0.05%	0.2%	0.5%	1%	2%	4%	6%				
471F	2000	100	0.0039	0.3	--	--	--	--	--	--	--	--	3.2	3.0	--
472F	2000	90	0.0039	0.3	--	--	--	--	--	--	--	--	2.0	3.0	--
473F	2000	80	0.0039	0.3	5.0	52	163	290	290	--	--	--	343	2.0	--
475F	2500	52	0.0052	0.20	11	37	78	97	102	102	--	--	103	3.0	--
476F	2500	42	0.0052	0.15	14	70	186	275	310	310	--	--	318	3.8	--
477F	3000	17	0.0075	0.55	4	12	45	140	225	485	670	--	695	9.0	--
478F	3000	12	0.0075	0.10	7	45	240	501	965	--	--	--	--	10.0	18.0
479F	3000	9	0.0075	0.20	45	128	341	1120	--	--	--	--	--	17.0	19.3

Reference: MPM 20.181

TABLE XI  
CREEP-RUPTURE PROPERTIES FOR COMMERCIALLY PURE SINTERED TUNGSTEN SHEET (0.020 inch) FROM 3500 TO 4500°F

Test Conditions:

- Machine = EPTM
- Method of heating = Resistance
- Gage length = 1.0 in.
- Sheet thickness = 0.020 in.
- Atmosphere = Argon - 7% Hydrogen
- Material = Uncoated, as-rolled, and stress relieved
- Specimens = Longitudinal

Spec. No.	Temp. (°F)	Stress (Ksi)	Approx. Thermal Exp. (in.)	Loading Strain (%)	Time (seconds) to Produce Indicated Plastic Creep										Plastic Creep in 1800 sec (sec)	Time to Rupture (sec)	Elong. (%)	Residual UTS (Ksi)
					Indicated Plastic Creep													
					0.05%	0.2%	0.5%	1.0%	2.0%	4.0%	6.0%	8.0%	10.0%					
588F	3500	14	0.0075	0.8	--	1.0	3.0	8.5	19	54	75	81	82	--	84	11	--	
589F	3500	10	0.0075	0.3	17	70	120	225	385	584	565	581	--	--	584	9	--	
590F	3500	10	0.0075	0.3	8	30	81	194	295	505	618	648	--	--	650	10	--	
591F	3500	6	0.0075	0.03	252	1560	--	--	--	--	--	--	--	0.24	--	11.5	15.1	
592F	3500	6	0.0075	0.02	230	1420	--	--	--	--	--	--	--	0.27	--	12.0	14.9	
593F	4000	12	0.0094	1.0	--	0.1	0.8	1.9	3.3	17	33	34	36	--	37	10.5	--	
597F	4000	10	0.0094	1.4	--	0.4	1.0	2.1	4.0	11	24	26	27	--	29	13	--	
595F	4000	8	0.0094	0.3	5	34	42	122	180	253	262	--	--	--	265	8	--	
596F	4000	4	0.0094	--	228	870	--	--	--	--	--	--	--	0.38	--	13	9.1	
598F	4500	7	0.0114	1.6	--	--	0.3	0.9	1.8	3.5	4.2	5.3	6.9	--	12	14	--	
599F	4500	6	0.0114	1.3	--	0.2	0.7	2.0	3.1	6.0	8.0	--	--	--	17	7	--	
600F	4500	6	0.0114	0.9	0.2	0.8	2.0	4.1	16	25	28	--	--	--	34	7	--	
601F	4500	5	0.0114	1.0	--	2.0	4.0	8.3	17	29	43	57	72	--	98	12	--	
602F	4500	4	0.0114	0.2	7	15	57	82	220	260	301	395	431	--	436	12	--	

Reference: MPM 20.181

UNCLASSIFIED

TABLE XII

BEND TRANSITION-TEMPERATURE TESTS FOR COMMERCIALY  
PURE SINTERED TUNGSTEN SHEET

Test Conditions

Machine = Baldwin  
Heating = Oil Bath  
Bend rate = 1.0 in./min  
Sheet thickness = 0.030 in.  
Specimens = Transverse to rolling direction

Specimen Number	Bend Radius	Temperature (°F)	Bend Angle (deg)	Remarks
22F	1T	300	35	Fractured
23F	1T	300	40	Fractured
24F	1T	400	41	Fractured
25F	1T	400	90	Fractured
46F	1T	400	95	Fractured
44F	1T	425	91	Fractured
45F	1T	425	130	Fractured
27F	1T	450	105	Fractured
28F	1T	450	126	Fractured
29F	1T	500	129	Fractured
31F	1T	500	120	Fractured
30F	1T	540	120	Fractured
37F	2T	200	0	Fractured
38F	2T	200	0	Fractured
39F	2T	300	55	Fractured
40F	2T	400	80	Fractured
41F	2T	400	103	Fractured
42F	2T	425	180	OK
43F	2T	425	110	Fractured
35F	2T	450	180	OK
36F	2T	450	180	OK
33F	2T	500	180	OK
32F	2T	540	132	Fractured
34F	2T	540	180	OK

Reference: MPM 20.180

MAC 4673

UNCLASSIFIED

UNCLASSIFIED

THE *Marquardt*  
CORPORATION  
VAN NUYS, CALIFORNIA

REPORT PR 281-2Q-3

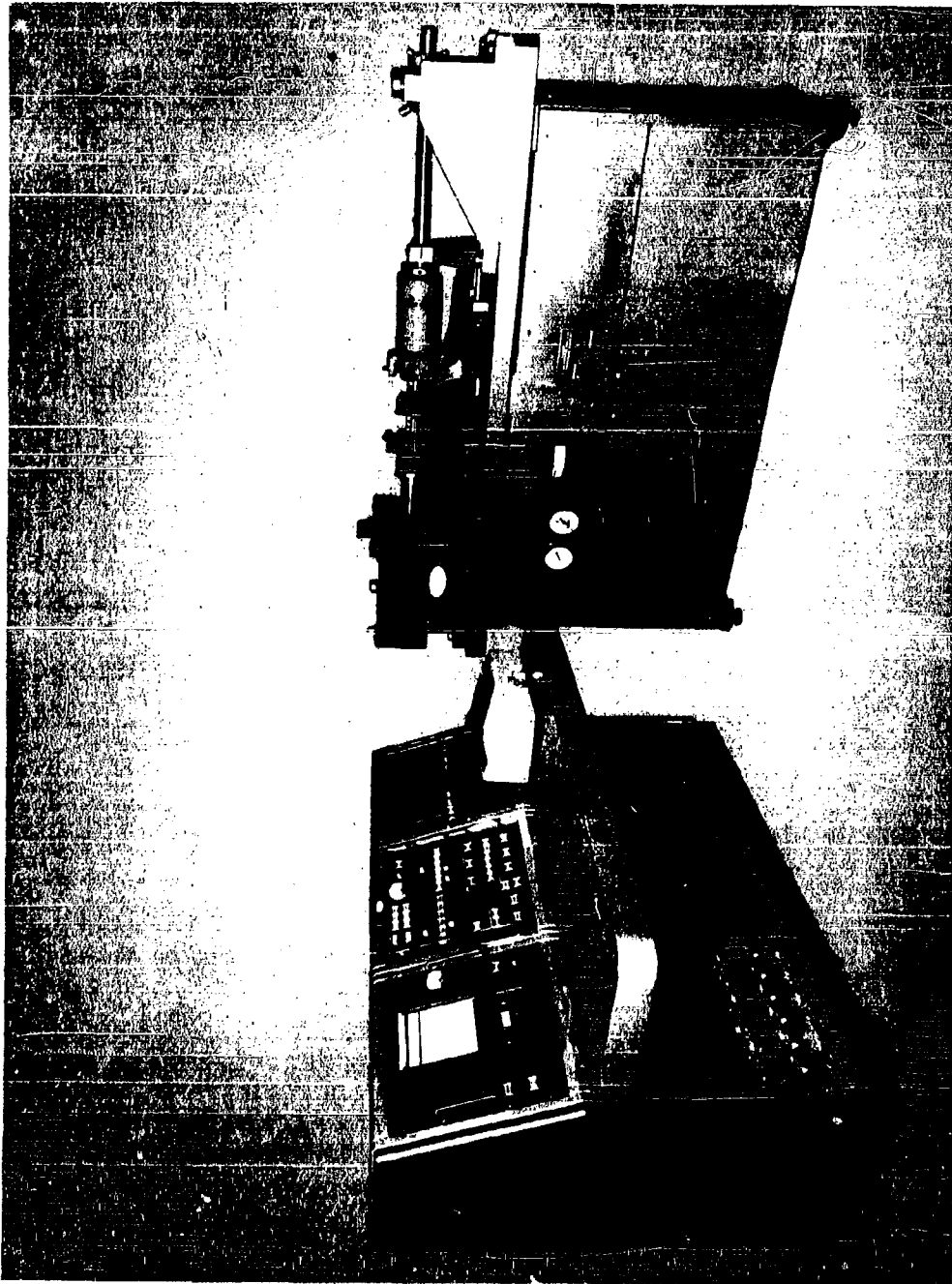

FIGURE 1 - The Marquardt TM-1A Elevated Temperature Test Machine

CA 2956-2

MAC AGS

UNCLASSIFIED

TEST SPECIMEN CONFIGURATION

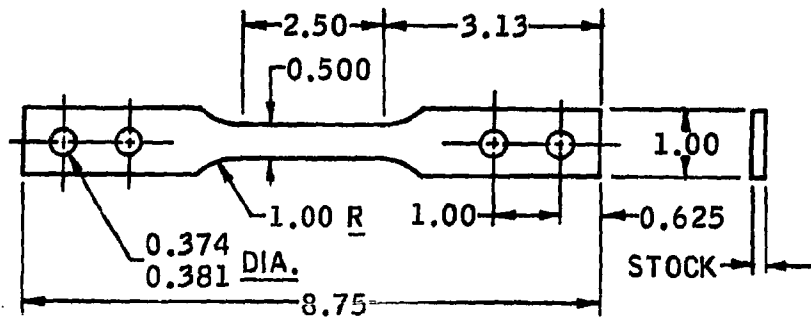

MAC A638

TENSILE PROPERTIES OF COMMERCIALY PURE  
 SINTERED TUNGSTEN SHEET

TEST CONDITIONS:

MACHINE - E.T.T.M.  
 METHOD OF HEATING - RESISTANCE  
 TIME TO TEST TEMPERATURE - 200°F/sec  
 HOLD TIME AT TEMPERATURE - 5 min  
 STRAIN RATE TO Y.S. - 0.001 in./in./sec  
 STRAIN RATE FROM Y.S. TO U.T.S. -  
 0.01 in./in./sec  
 GAUGE LENGTH - 1.0 in.  
 ATMOSPHERE - ARGON - 7% HYDROGEN  
 MATERIAL - UNCOATED, AS ROLLED,  
 AND STRESS RELIEVED  
 SPECIMENS LONGITUDINAL

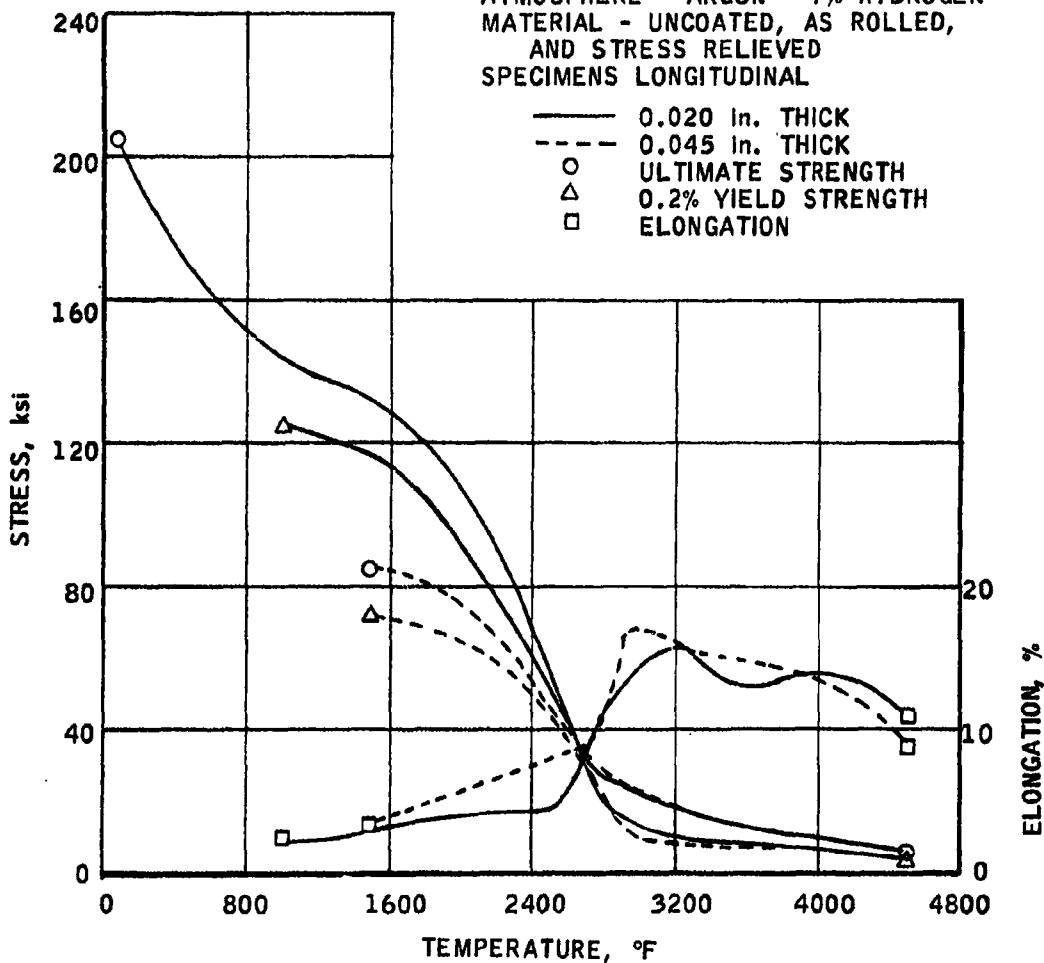

R-9891

MAC 603

### HIGH TEMPERATURE TENSILE PROPERTIES OF COMMERCIALY PURE SINTERED TUNGSTEN SHEET

TEST CONDITIONS:

MACHINE - E.T.T.M.  
METHOD OF HEATING - RESISTANCE  
TIME TO TEST TEMPERATURE - 200°F/sec  
HOLD TIME AT TEMPERATURE - 5 min  
STRAIN RATE TO Y.S. - 0.001 in./in./sec  
STRAIN RATE FROM Y.S. TO U.T.S. -  
0.01 in./in./sec  
GAUGE LENGTH - 1.0 in.  
ATMOSPHERE - ARGON - 7% HYDROGEN  
MATERIAL - UNCOATED, AS ROLLED,  
AND STRESS RELIEVED  
SPECIMENS LONGITUDINAL

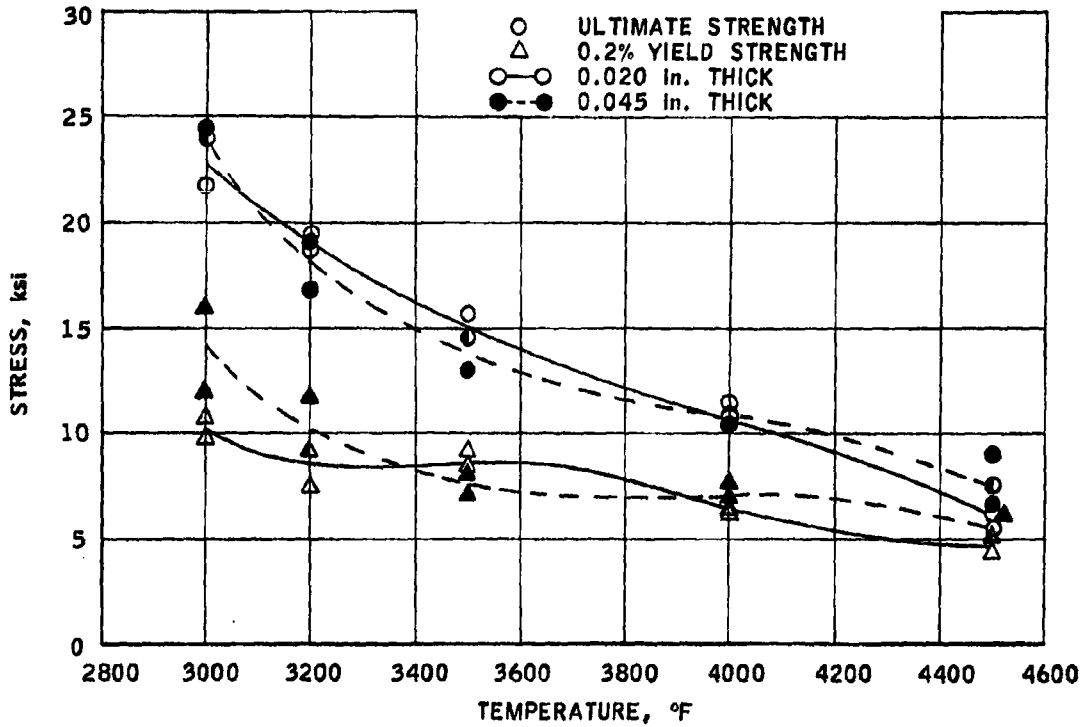

R-9892

MAC A673

PLASTIC CREEP PROPERTIES OF COMMERCIALY PURE  
SINTERED TUNGSTEN SHEET AT 3000 °F

SHEET THICKNESS - 0.045 in.

TEST CONDITIONS:

METHOD OF HEATING - RESISTANCE  
GAUGE LENGTH - 1.0 in.  
ATMOSPHERE - ARGON - 7% HYDROGEN  
LOADING STRAIN - 0.42% *av.*  
MATERIAL - UNCOATED, AS ROLLED,  
AND STRESS RELIEVED  
SPECIMENS - LONGITUDINAL

R-9893

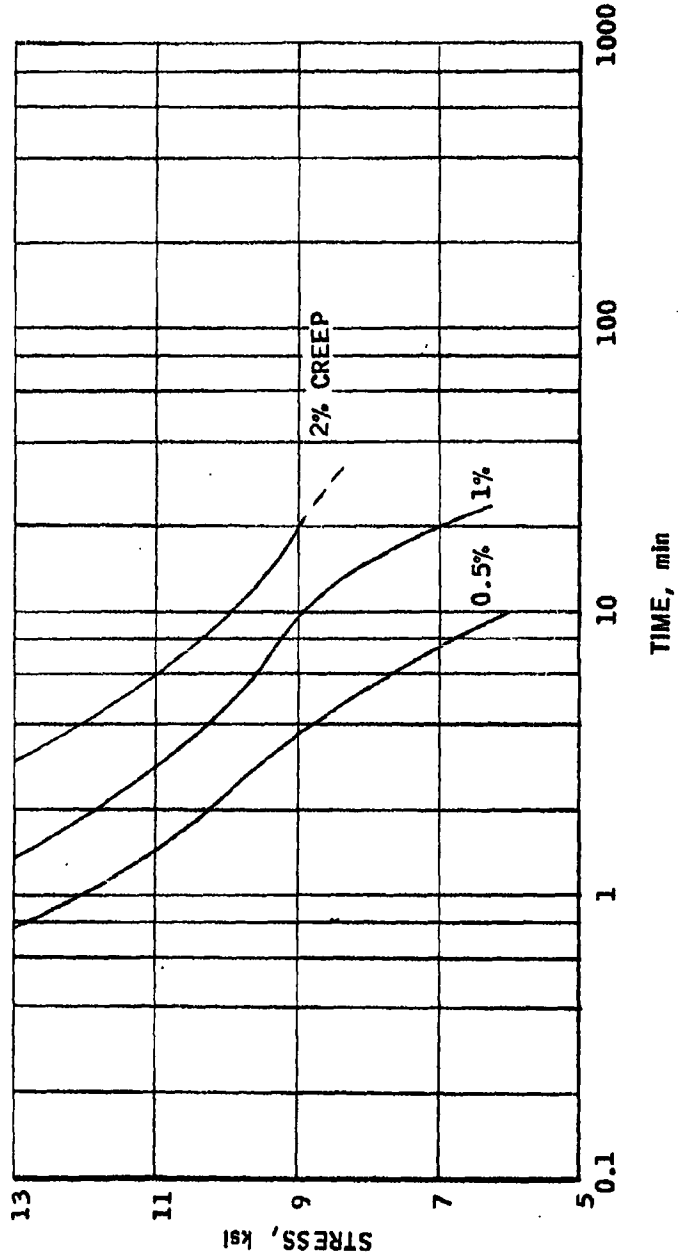

MAC 6673

PLASTIC CREEP - RUPTURE PROPERTIES OF COMMERCIALY PURE  
SINTERED TUNGSTEN SHEET AT 3500 °F

SHEET THICKNESS - 0.045 in.

TEST CONDITIONS:

METHOD OF HEATING - RESISTANCE  
GAUGE LENGTH - 1.0 in.  
ATMOSPHERE - ARGON - 7% HYDROGEN  
LOADING STRAIN - 0.5% av.  
MATERIAL - UNCOATED, AS ROLLED,  
AND STRESS RELIEVED  
SPECIMENS - LONGITUDINAL

R-9894 A

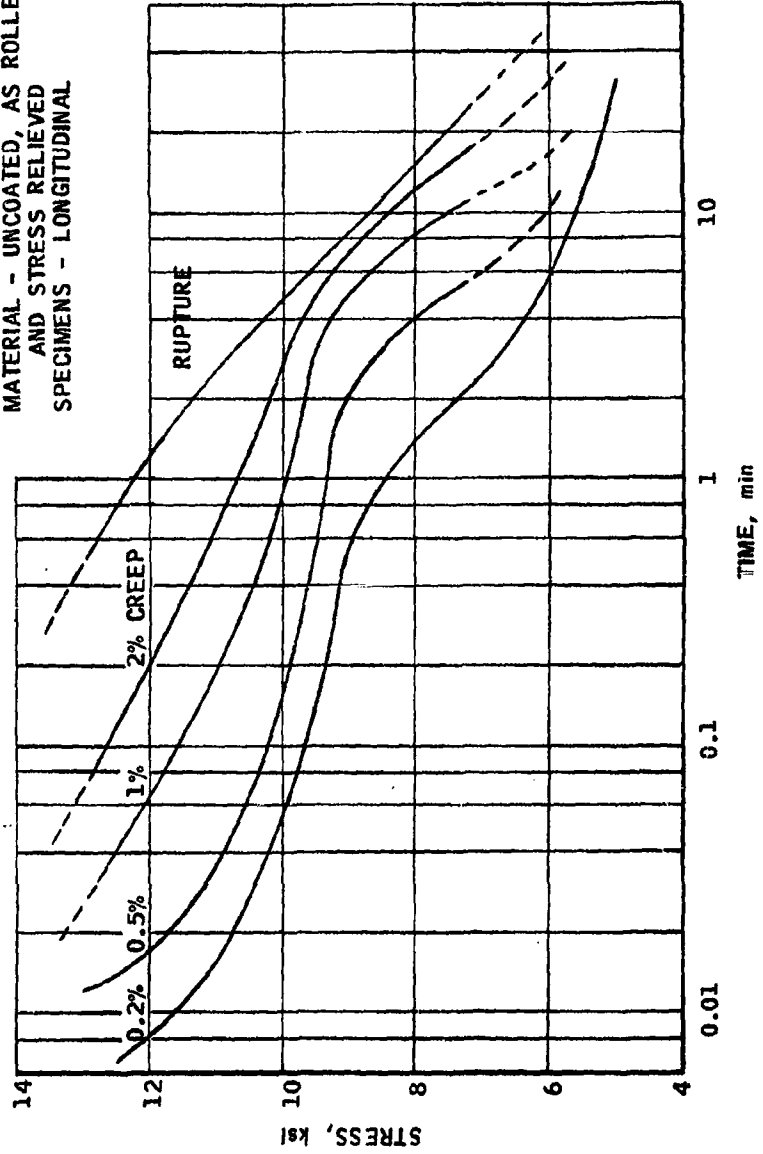

MAC 463

PLASTIC CREEP-RUPTURE PROPERTIES  
FOR COMMERCIALY PURE SINTERED TUNGSTEN SHEET AT 4000° F

SHEET THICKNESS - 0.045 in.

TEST CONDITIONS:

METHOD OF HEATING - RESISTANCE  
LOADING STRAIN - 0.78% av.  
GAUGE LENGTH - 1.0 in.  
ATMOSPHERE - ARGON - 7% HYDROGEN  
MATERIAL - UNCOATED, AS ROLLED,  
AND STRESS RELIEVED  
SPECIMENS - LONGITUDINAL

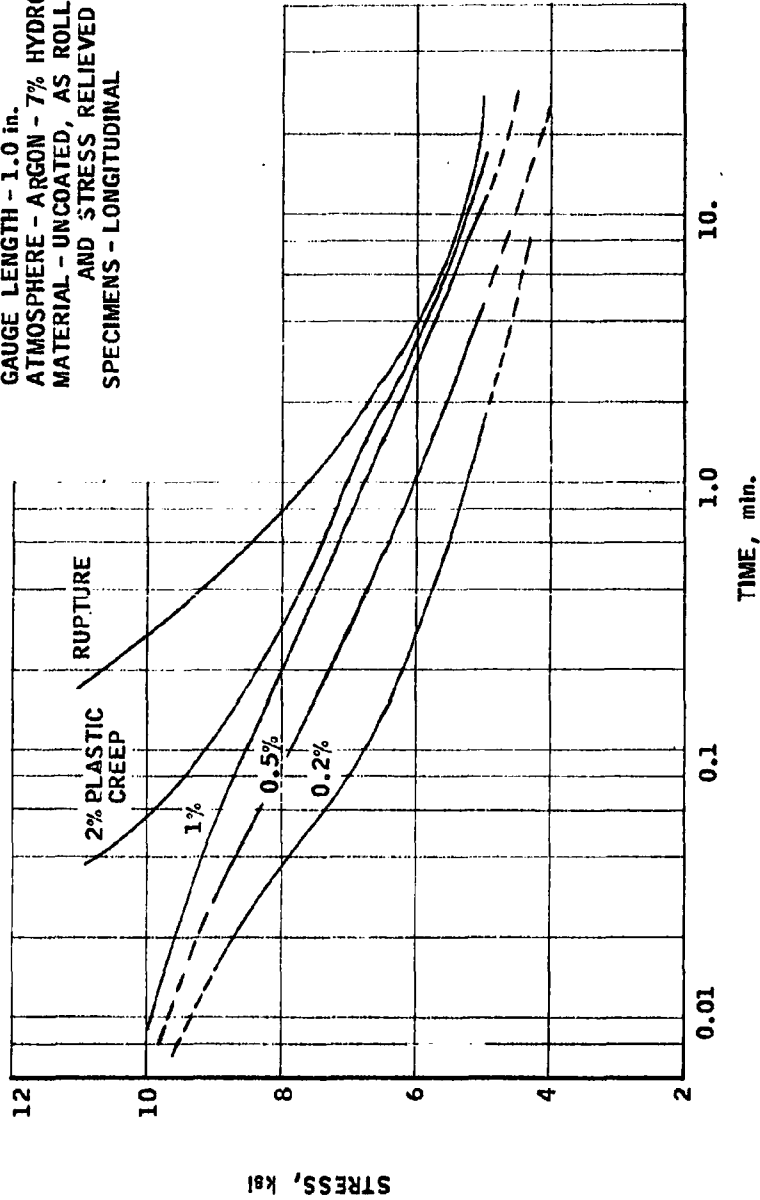

R-9998

MAC A678

PLASTIC CREEP-RUPTURE PROPERTIES  
FOR COMMERCIALLY PURE SINTERED TUNGSTEN SHEET AT 4500°F  
SHEET THICKNESS - 0.045 in.

TEST CONDITIONS:

METHOD OF HEATING - RESISTANCE  
LOADING STRAIN - 0.8% av.  
GAUGE LENGTH - 1.0 in.  
ATMOSPHERE - ARGON - 7% HYDROGEN  
MATERIAL - UNCOATED, AS ROLLED,  
AND STRESS RELIEVED  
SPECIMENS - LONGITUDINAL

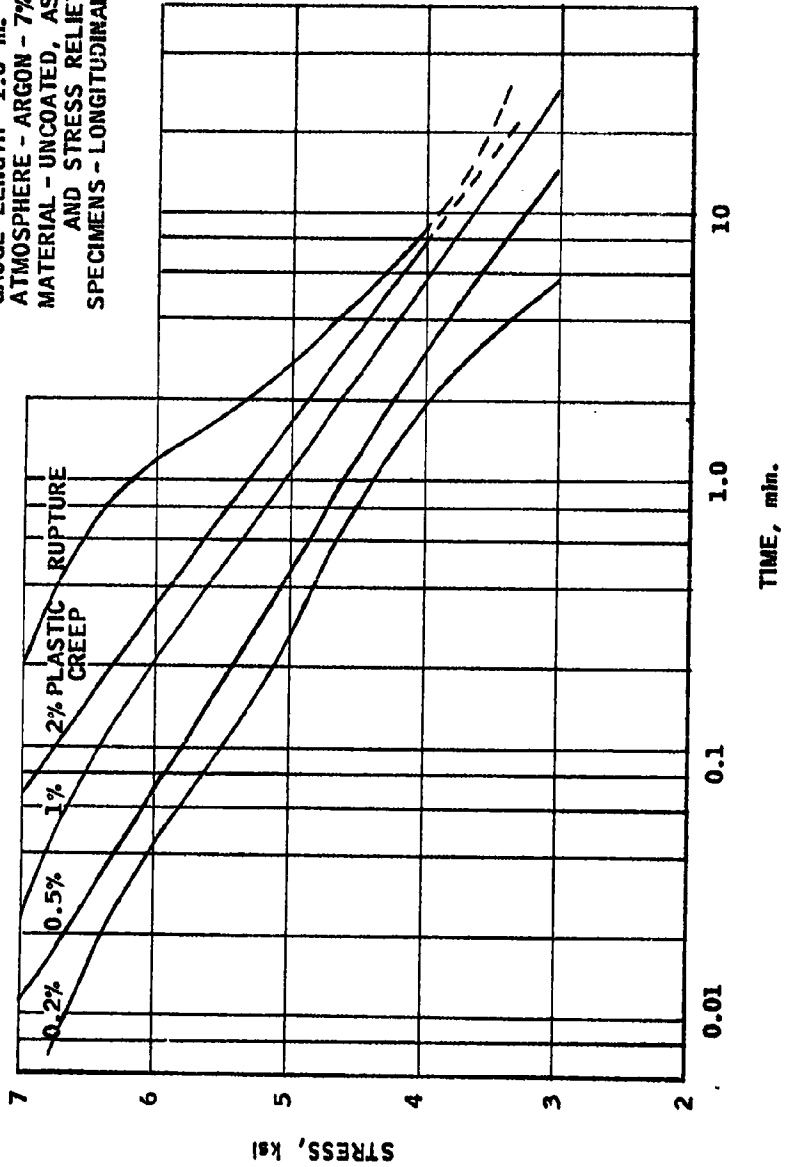

R-9997A

MAC A673

PLASTIC CREEP PROPERTIES OF COMMERCIALY PURE  
SINTERED TUNGSTEN SHEET AT 3000 °F  
SHEET THICKNESS - 0.020 in.

TEST CONDITIONS:

METHOD OF HEATING - RESISTANCE  
GAUGE LENGTH - 1.0 in.  
ATMOSPHERE - ARGON - 7% HYDROGEN  
LOADING STRAIN - 0.28% av.  
MATERIAL - UNCOATED, AS ROLLED,  
AND STRESS RELIEVED  
SPECIMENS - LONGITUDINAL

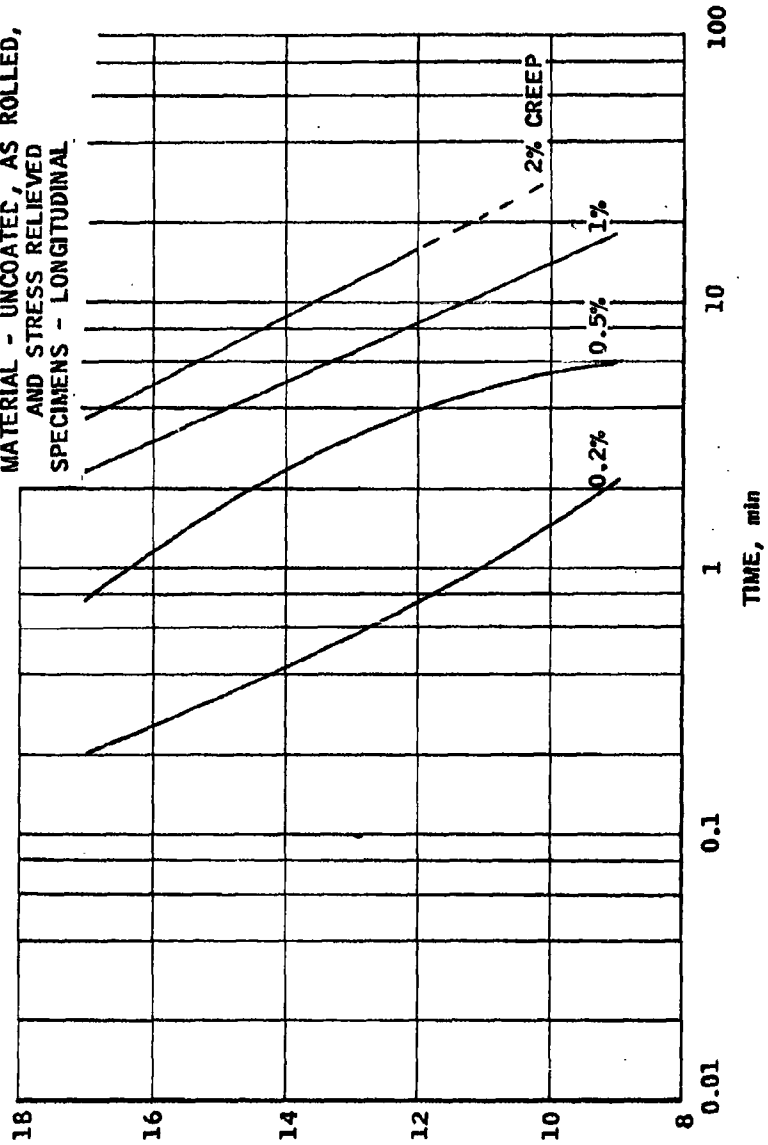

R-9895

MAC 663

PLASTIC CREEP-RUPTURE PROPERTIES  
FOR COMMERCIALY PURE SINTERED TUNGSTEN SHEET AT 3500° F

SHEET THICKNESS - 0.020 in.

TEST CONDITIONS:  
METHOD OF HEATING - RESISTANCE  
LOADING STRAIN - 0.3% av.  
GAUGE LENGTH - 1.0 in.  
ATMOSPHERE - ARGON - 7%  
HYDROGEN  
MATERIAL - UNCOATED, AS ROLLED  
AND STRESS RELIEVED  
SPECIMENS - LONGITUDINAL

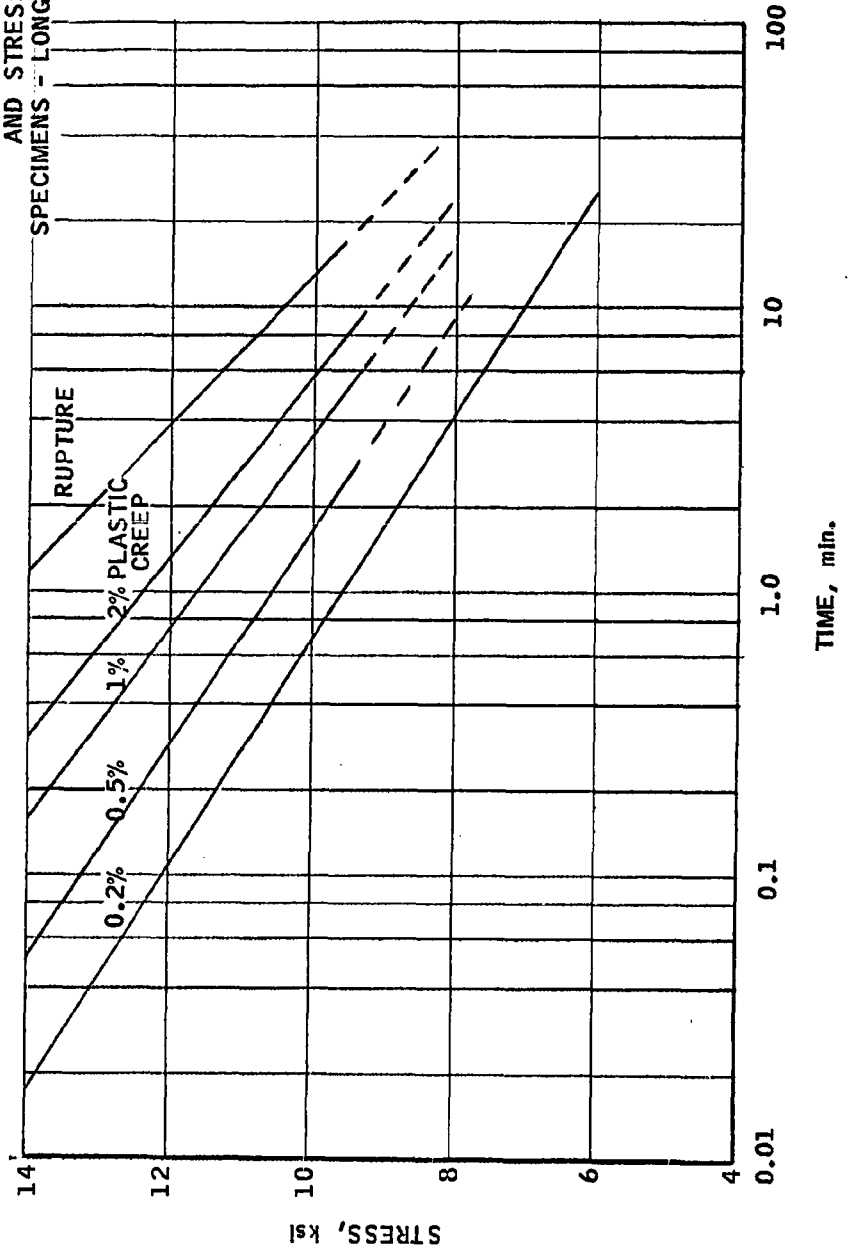

R-9996

MAC 6673

PLASTIC CREEP-RUPTURE PROPERTIES  
FOR COMMERCIALY PURE SINTERED TUNGSTEN SHEET AT 4000°F  
SHEET THICKNESS - 0.020 in.

TEST CONDITIONS:

METHOD OF HEATING - RESISTANCE  
LOADING STRAIN - 0.9% av.  
GAUGE LENGTH - 1.0 in.  
ATMOSPHERE - ARGON - 7% HYDROGEN  
MATERIAL - UNCOATED, AS ROLLED,  
AND STRESS RELIEVED  
SPECIMENS - LONGITUDINAL

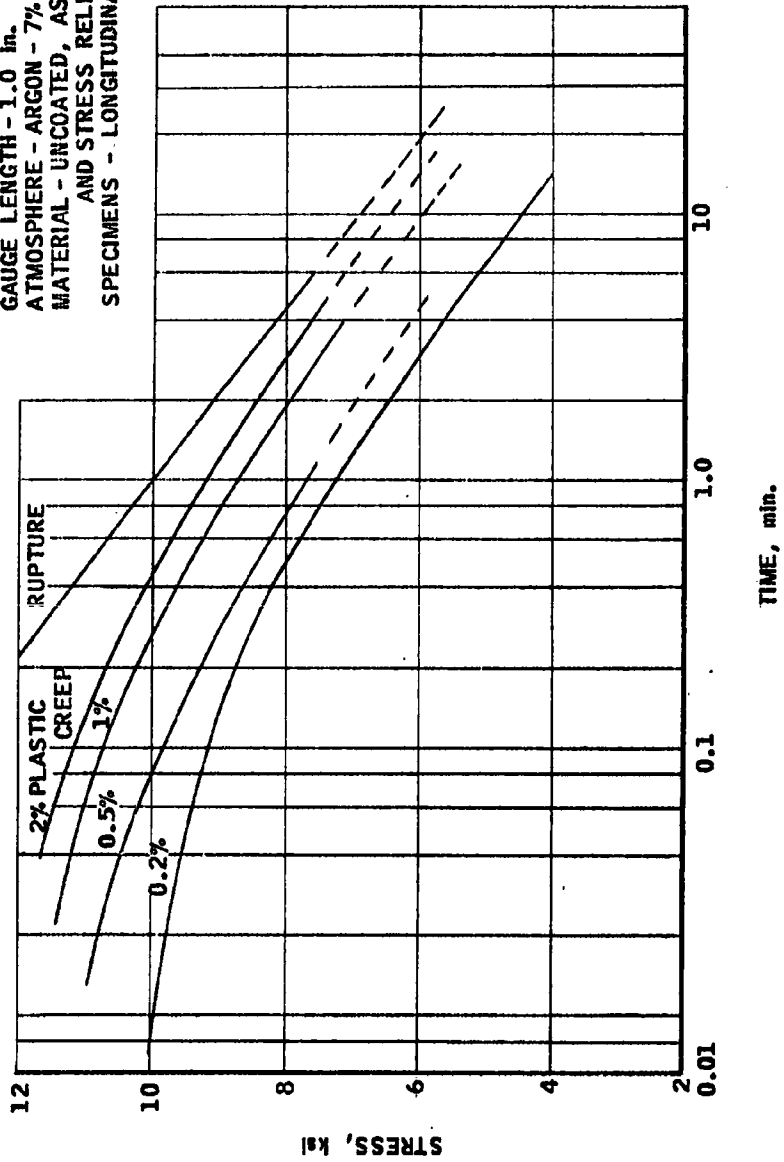

MAC A673

R-9995A

PLASTIC CREEP-RUPTURE PROPERTIES FOR COMMERCIALY PURE SINTERED TUNGSTEN SHEET AT 4500° F

SHEET THICKNESS - 0.020 in.

R-9994

TEST CONDITIONS:

- METHOD OF HEATING - RESISTANCE
- LOADING STRAIN - 1.0% av.
- GAUGE LENGTH - 1.0 in.
- ATMOSPHERE - ARGON - 7% HYDROGEN
- MATERIAL - UNCOATED, AS ROLLED, AND STRESS RELIEVED
- SPECIMENS LONGITUDINAL

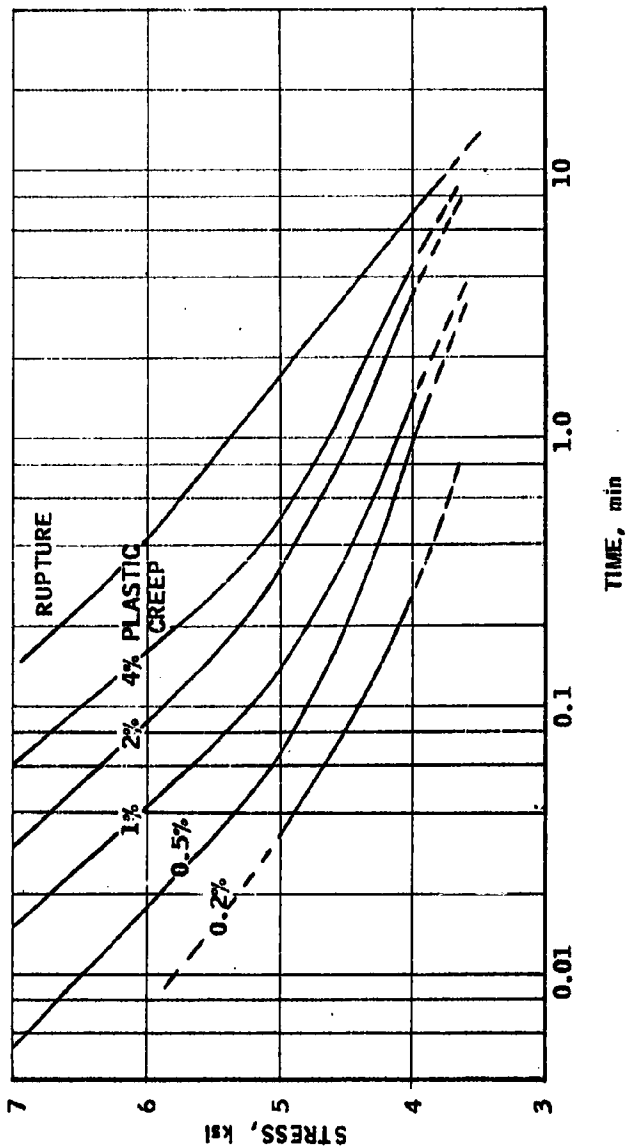

MAC A 673

STRESS TO PRODUCE 1% PLASTIC CREEP AND RUPTURE  
IN 10 MINUTES FOR COMMERCIALY PURE SINTERED TUNGSTEN SHEET

TEST CONDITIONS:

METHOD OF HEATING - RESISTANCE  
GAUGE LENGTH - 1.0 in.  
ATMOSPHERE - ARGON - 7% HYDROGEN  
MATERIAL - UNCOATED AND STRESS  
RELIEVED  
SPECIMENS -- LONGITUDINAL

————— 0.020 in. THICK  
----- 0.045 in. THICK

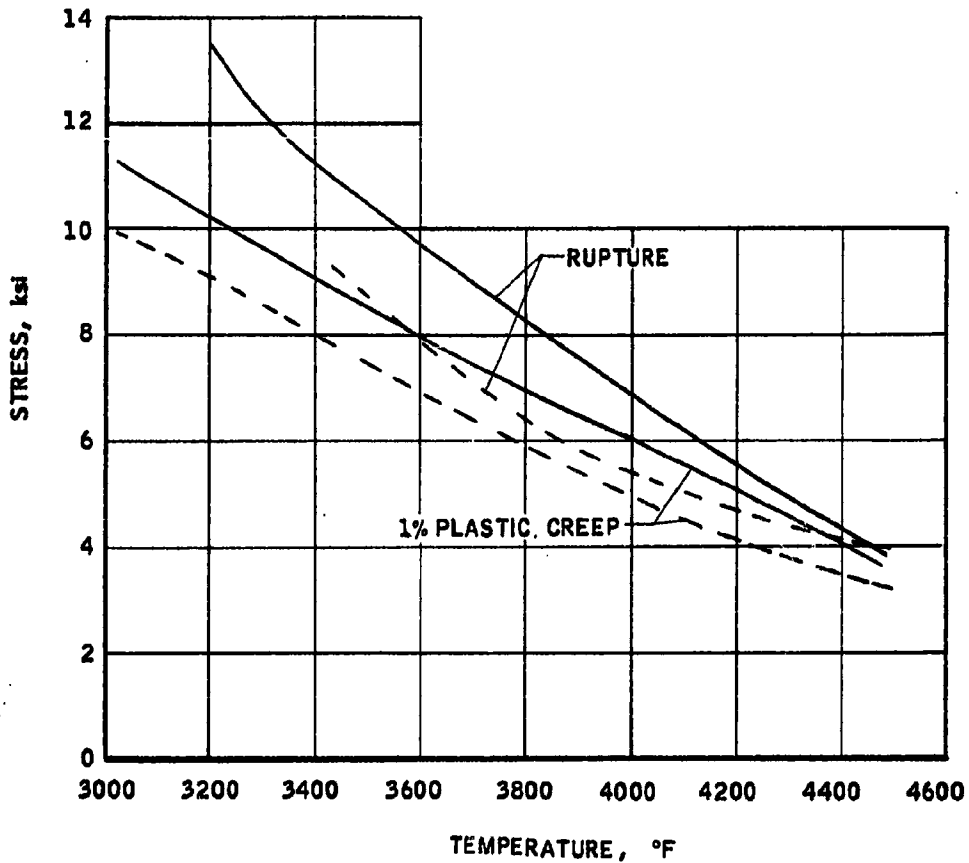

R-9993

MAC A673

0.020 INCH THICK

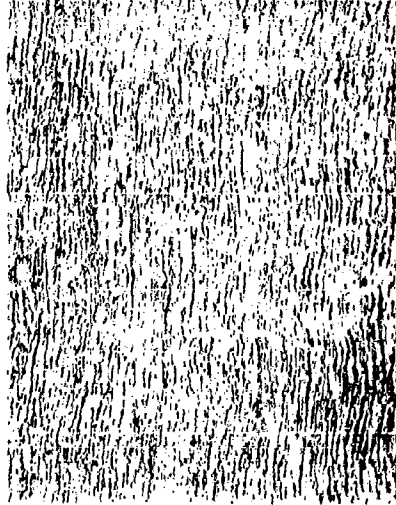

AS RECEIVED

0.045 INCH THICK

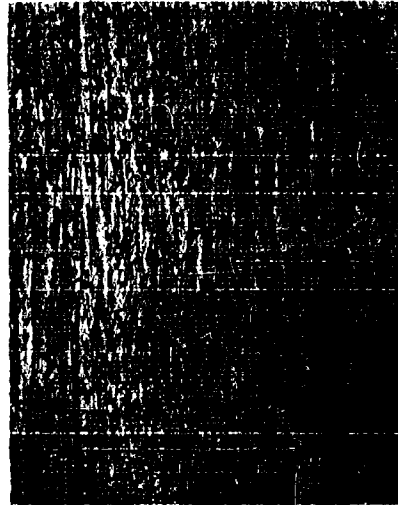

AS RECEIVED

MAG: 500 X  
ETCHANT: MURAKAMI'S ETCH



TESTED AT 2750°F



TESTED AT 2750°F

CA 3994-1

FIGURE 14 - Microstructure of Commercially Pure Sintered Tungsten Sheet

MAC A678

0.2% YIELD STRENGTH TO DENSITY RATIO  
FOR VARIOUS REFRACTORY METALS AND ALLOYS

TEST CONDITIONS:

METHOD OF HEATING - RESISTANCE  
STRAIN RATE TO Y.S. - 0.001 in./in./sec  
STRAIN RATE FROM Y.S. TO U.T.S. - 0.01 in./in./sec  
ATMOSPHERE - INERT GAS  
MATERIAL - UNCOATED AND STRESS RELIEVED  
SPECIMENS LONGITUDINAL

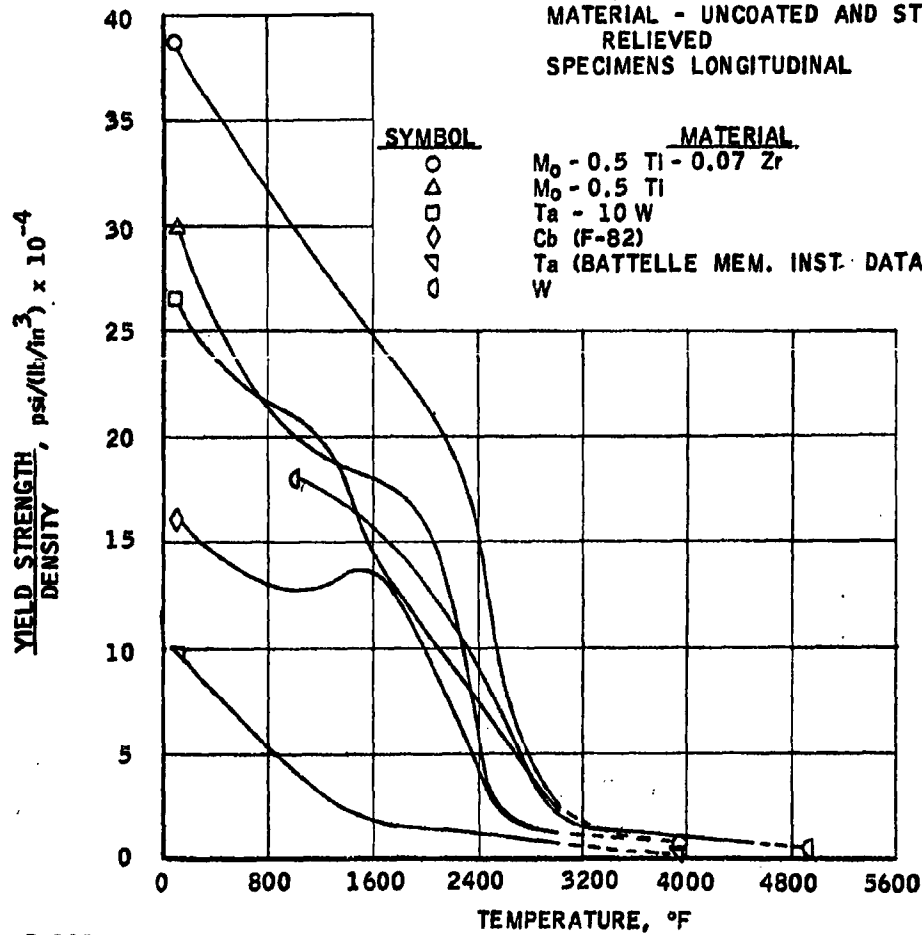

R-9992

MAC A67B

STRESS TO PRODUCE 1% PLASTIC CREEP IN 10 MINUTES  
FOR VARIOUS REFRACTORY METAL ALLOY SHEETS

TEST CONDITIONS:

METHOD OF HEATING - RESISTANCE  
ATMOSPHERE - INERT GAS  
MATERIAL - UNCOATED AND STRESS  
RELIEVED  
SPECIMENS LONGITUDINAL

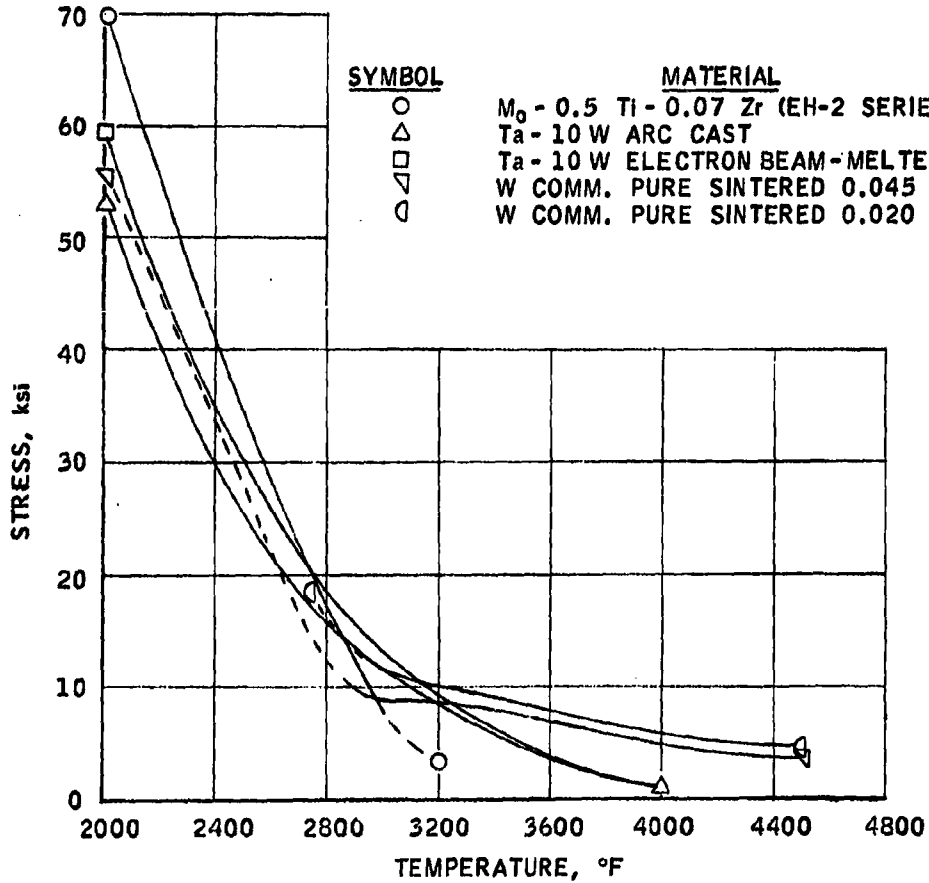

R-9991

MAC A673

**STRESS TO PRODUCE RUPTURE IN 10 MINUTES  
FOR VARIOUS REFRACTORY METAL ALLOY SHEETS**

**TEST CONDITIONS:**

METHOD OF HEATING - RESISTANCE  
ATMOSPHERE - INERT GAS  
MATERIAL - UNCOATED AND STRESS  
RELIEVED  
SPECIMENS LONGITUDINAL

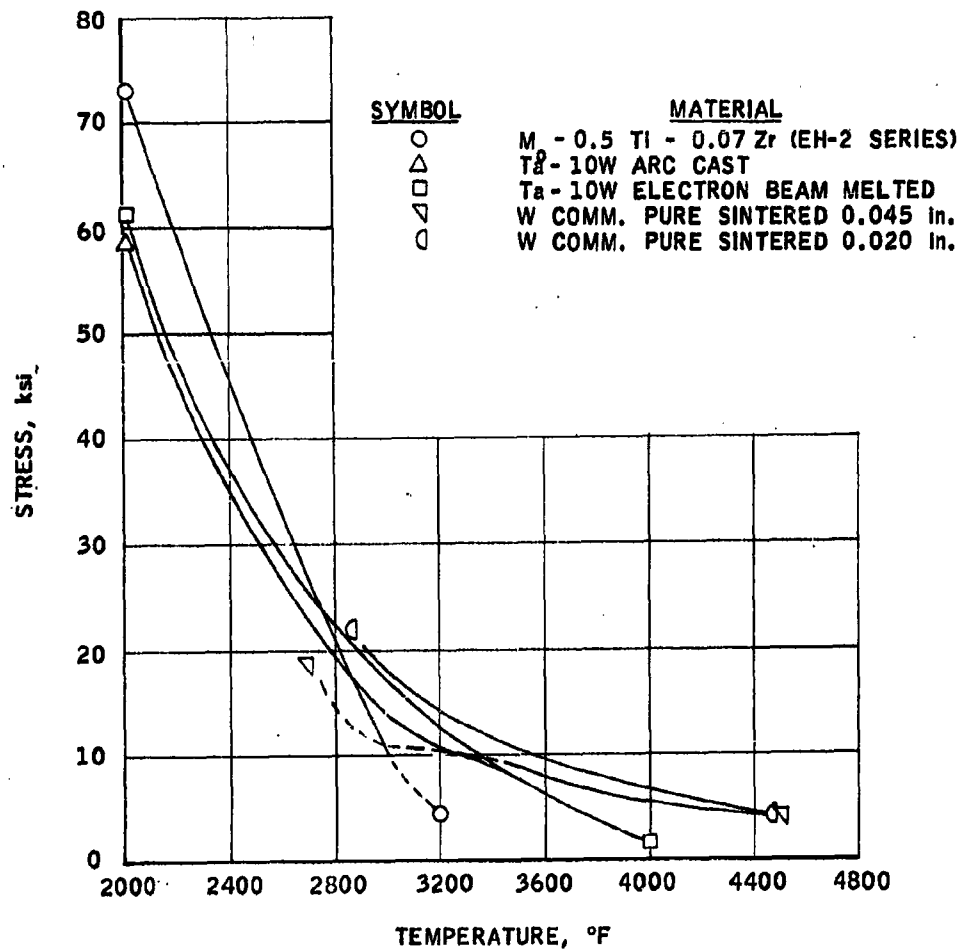

R-9990

MAC 6573

BEND TRANSITION-TEMPERATURE PROPERTIES  
FOR COMMERCIALY PURE SINTERED TUNGSTEN SHEET

TEST CONDITIONS:

MACHINE - BALDWIN  
METHOD OF HEATING - OIL BATH  
BENDING RATE - 1.0 in./min  
SHEET THICKNESS - 0.030 in.  
SPECIMENS TRANSVERSE

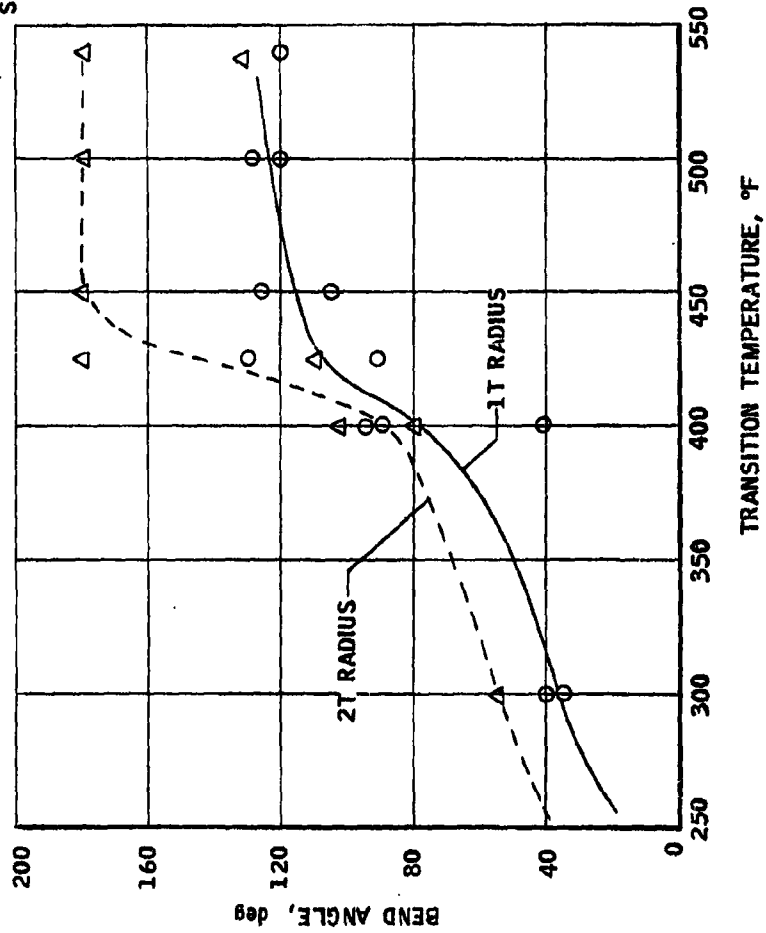

R-9999

MAC A673

DISTRIBUTION

<u>Copy No.</u>	<u>Transmitted to</u>
1.	Syracuse University Research Institute Department of Chemical Eng. & Metallurgy Syracuse 10, N. Y. Attn.: Dr. Volker Weiss
2.	Syracuse University Research Institute Box 145, University Station Syracuse 10, N. Y. Attn.: Dr. C. S. Grove, Jr.
3.	Defense Metals Information Center Battelle Memorial Institute 505 King Avenue Columbus 1, Ohio
4, 5.	Commander Aeronautical Systems Division Directorate of Materials & Processes Wright-Patterson AFB, Ohio Attn.: ASRCM-1
6.	Thermophysical Properties Research Center School of Mechanical Engineering Lafayette, Indiana Attn.: Dr. Y. S. Touloukian
7.	Plastec Picatinny Arsenal Dover, New Jersey
8.	Belfour Engineering Co. Suttons Bay, Michigan Attn.: Albert J. Belfour
9.	Hughes Aircraft Company Florence and Teale Streets Culver City, California Attn.: E. M. Wallace, Library Services
10.	Commander Aeronautical Systems Division Directorate of Materials & Processes Wright-Patterson AFB, Ohio Attn.: ASRCEE

MAC 4673

UNCLASSIFIED

THE *Marquardt*  
CORPORATION  
VAN NUYS, CALIFORNIA

REPORT PR 281-20-3

DISTRIBUTION (Continued)

<u>Copy No.</u>	<u>Transmitted to</u>
11 to 20.	Armed Services Technical Information Agency Arlington Hall Station Arlington 12, Virginia Attn.: TIPA
21.	Forest Products Laboratory Madison 5, Wisconsin Attn.: Mr. Fred Werren
22.	Commander Aeronautical Systems Division Directorate of Materials and Processes Wright-Patterson AFB, Ohio Attn.: ASRCM-1, Library

MAC AFB

UNCLASSIFIED