

UNCLASSIFIED

AD 292 273

*Reproduced
by the*

ARMED SERVICES TECHNICAL INFORMATION AGENCY
ARLINGTON HALL STATION
ARLINGTON 12, VIRGINIA



UNCLASSIFIED

NOTICE: When government or other drawings, specifications or other data are used for any purpose other than in connection with a definitely related government procurement operation, the U. S. Government thereby incurs no responsibility, nor any obligation whatsoever; and the fact that the Government may have formulated, furnished, or in any way supplied the said drawings, specifications, or other data is not to be regarded by implication or otherwise as in any manner licensing the holder or any other person or corporation, or conveying any rights or permission to manufacture, use or sell any patented invention that may in any way be related thereto.



RESEARCH AND DEVELOPMENT

292 273

GIRDLER CORPORATION
LOUISVILLE, KENTUCKY



NObs - 8674

DESIGN STUDY
ON
THE GENERATION OF HYDROGEN FROM METHANOL
FOR
FUEL CELL SYSTEMS ON BOARD SUBMARINES

FOR
BUREAU OF SHIPS
UNITED STATES NAVY
CONTRACT NObs - 86743
SERIAL NO. SF013-06-04 - TASK 4377

GIRDLER JOB NO. 131-5414
COPY NO. 5

365 100

ASTIA
RECEIVED
JAN 3 1963
ASTIA

GIRDLER CORPORATION
LOUISVILLE, KENTUCKY

OCTOBER 12, 1962

REPORT BY:

H. A. Bennett Jr.
H.A. Bennett, Jr.

J. P. Bocard
J.P. Bocard

R. L. Harvin
Dr. R. L. Harvin

B. J. Mayland
Dr. B.J. Mayland

J. C. Reynolds
J.C. Reynolds

GIRDLER CORPORATION
LOUISVILLE, KENTUCKY

October 12, 1962

TABLE OF CONTENTS

| | <u>Page No.</u> |
|--|-----------------|
| I. SUMMARY | I-1 |
| II. INTRODUCTION | II-1 |
| III. GENERAL REVIEW OF HYDROGEN PRODUCTION FROM METHANOL | III-1 |
| A. General Discussion | III-1 |
| 1. Generation | III-1 |
| a. Reforming | III-1 |
| b. Adiabatic Reaction | III-1 |
| c. Thermal and Catalytic Cracking | III-2 |
| 2. Purification | III-2 |
| a. Carbon Dioxide Removal | III-3 |
| b. Carbon Monoxide Removal | III-3 |
| B. Review of Catalysts Information | III-4 |
| C. Equilibrium Study and Thermodynamic Considerations | III-5 |
| 1. Product Composition | III-5 |
| a. Adiabatic Reaction | III-5 |
| b. Reforming | III-7 |
| 2. Enthalpic Considerations | III-8 |
| a. Reactor Inlet Temperature | III-8 |
| b. Heat Input Requirement | III-8 |
| c. Flame Temperature | III-9 |
| D. Physical and Thermodynamic Properties | III-9 |

| | <u>Page No.</u> |
|--|-----------------|
| IV. DISCUSSION OF PRELIMINARY PROCESS STUDIES | IV-1 |
| A. Adiabatic Reactor | IV-1 |
| 1. Steam Ratio of 2.0:1 | IV-1 |
| 2. Steam Ratio of 4.0:1 | IV-2 |
| B. Reformer | IV-2 |
| C. Palladium Diffusion Purification | IV-3 |
| 1. General | IV-3 |
| 2. Treatment of Total Crude Product | IV-4 |
| 3. Treatment of Crude Product with Water Removed | IV-5 |
| 4. Treatment of Crude Product with Water and Carbon Dioxide Removed | IV-5 |
| D. Purification by Low Temperature Absorption in Methanol | IV-6 |
| E. Purification by Low Temperature Adsorption | IV-7 |
| F. Purification by Girbotol Scrubbing and Methanation | IV-8 |
| V. PLANT DESIGN | V-1 |
| A. Process | V-1 |
| 1. General | V-1 |
| 2. Selection of Non-Adiabatic Process | V-1 |
| 3. Selection of Concentric Tube Design | V-3 |
| 4. Selection of Palladium Diffusion Purification | V-5 |
| 5. Pressure Level of Operation | V-7 |
| 6. Oxygen Addition for Process Assist | V-7 |
| 7. Discussion of Flow Diagram | V-9 |
| B. Detailed Process Calculations | V-13 |
| 1. Material and Heat Balance | V-13 |

| | <u>Page No.</u> |
|--|-----------------|
| 2. Utility Requirements | V-27 |
| 3. Equipment Sizing | V-28 |
| C. Mechanical Details of Major Equipment | V-33 |
| D. Instrumentation | V-33 |
| E. Physical | V-35 |
| VI. DISCUSSION OF CHARACTERISTICS | VI-1 |
| A. Physical | VI-1 |
| 1. Design Advantages | VI-1 |
| 2. Desirable Alternatives | VI-2 |
| 3. Scale-up | VI-3 |
| B. Operating | VI-3 |
| 1. Start-up | VI-3 |
| 2. Normal Operation | VI-5 |
| 3. Shut-down | VI-6 |
| 4. Power Consumption at Various Rates | VI-7 |
| 5. Response Time | VI-7 |
| 6. On-stream Factor | VI-8 |
| C. General | VI-8 |
| 1. Fuel | VI-8 |
| 2. Disposal of Waste Gases | VI-9 |
| 3. Air Operation | VI-9 |
| VII. DISCUSSION OF DESIGN VERIFICATION | VII-1 |
| A. Process | VII-1 |
| B. Equipment | VII-3 |

C. Instrumentation

D. Experimental Plan

VIII. APPENDIX

LIST OF TABLES

| <u>TABLE</u> <u>No.</u> | <u>TITLE</u> |
|----------------------------|---|
| III-1 | Summary of Catalyst Results |
| III-2-1 | Physical Properties of Methanol |
| III-2-2 | Specifications of Methanol |
| III-3 | Enthalpy and Physical Properties of Oxygen |
| III-4 | Enthalpy and Physical Properties of Hydrogen |
| III-5 | Enthalpy and Physical Properties of Water |
| III-6 | Enthalpy and Physical Properties of Carbon Monoxide |
| III-7 | Enthalpy and Physical Properties of Carbon Dioxide |
| III-8 | Enthalpy and Physical Properties of Methane |
| III-9 | Enthalpy and Physical Properties of Methanol |
| III-10 | Equilibrium Constants and Heats of Reaction for the Water Gas Shift Reaction |
| V-1 | Summary of Raw Materials and Utilities at Various Rates |

LIST OF FIGURES

| <u>FIGURE</u> <u>No.</u> | <u>TITLE</u> |
|-----------------------------|--|
| III-C-1 | Oxygen Requirement for Adiabatic Reaction at 400°F. |
| III-C-2 | Oxygen Requirement for Adiabatic Reaction at 400°F. |
| III-C-3 | Oxygen Requirement for Adiabatic Reaction at 600°F. |
| III-C-4 | Oxygen Requirement for Adiabatic Reaction at 600°F. |
| III-C-5 | Oxygen Requirement for Adiabatic Reaction at 800°F. |
| III-C-6 | Oxygen Requirement for Adiabatic Reaction at 800°F. |
| III-C-7 | Carbon Monoxide Production In Adiabatic Reaction at 400°F. |
| III-C-8 | Carbon Monoxide Production In Adiabatic Reaction at 400°F. |
| III-C-9 | Carbon Dioxide Production In Adiabatic Reaction at 400°F. |
| III-C-10 | Carbon Dioxide Production In Adiabatic Reaction at 400°F. |
| III-C-11 | Hydrogen Production In Adiabatic Reaction at 400°F. |
| III-C-12 | Hydrogen Production in Adiabatic Reaction at 400°F. |
| III-C-13 | Water Production In Adiabatic Reaction at 400°F. |
| III-C-14 | Water Production In Adiabatic Reaction at 400°F. |
| III-C-15 | Carbon Monoxide Production In Adiabatic Reaction at 600°F. |
| III-C-16 | Carbon Monoxide Production In Adiabatic Reaction at 600°F. |
| III-C-17 | Carbon Dioxide Production In Adiabatic Reaction at 600°F. |
| III-C-18 | Carbon Dioxide Production in Adiabatic Reaction at 600°F. |
| III-C-19 | Hydrogen Production In Adiabatic Reaction at 600°F. |
| III-C-20 | Hydrogen Production In Adiabatic Reaction at 600°F. |
| III-C-21 | Water Production In Adiabatic Reaction at 600°F. |
| III-C-22 | Water Production In Adiabatic Reaction at 600°F. |

LIST OF FIGURES
Contd.

| <u>FIGURE</u> <u>No.</u> | <u>TITLE</u> |
|-----------------------------|---|
| III-C-23 | Carbon Monoxide Production In Adiabatic Reaction at 800°F. |
| III-C-24 | Carbon Monoxide Production In Adiabatic Reaction at 800°F. |
| III-C-25 | Carbon Dioxide Production In Adiabatic Reaction at 800°F. |
| III-C-26 | Carbon Dioxide Production In Adiabatic Reaction at 800°F. |
| III-C-27 | Hydrogen Production In Adiabatic Reaction at 800°F. |
| III-C-28 | Hydrogen Production In Adiabatic Reaction at 800°F. |
| III-C-29 | Water Production In Adiabatic Reaction at 800°F. |
| III-C-30 | Water Production In Adiabatic Reaction at 800°F. |
| III-C-31 | Effect of Reaction Temperature on Hydrogen Production In Adiabatic Reaction |
| III-C-32 | Reactor Inlet Temperature at Various Steam Ratios For Adiabatic Reaction of Methanol and Steam |
| III-C-33 | Preheat Requirement at Various Steam Ratios |
| III-C-34 | Heat Requirement at Various Steam Ratios, Reaction Temperature = 400°F. |
| III-C-35 | Heat Requirement at Various Steam Ratios, Reaction Temperature = 600°F. |
| III-C-36 | Heat Requirement at Various Steam Ratios, Reaction Temperature = 800°F. |
| III-C-37 | Total Heat Requirement at Various Steam Ratios |
| III-C-38 | Effect of Steam Ratio On Flame Temperature |
| III-D-1 | Vapor Pressure of Methanol and Water |
| IV-A | Flow Diagram, Gas Generation Adiabatic Reactor |
| IV-B | Flow Diagram, Gas Generation Reformer Furnace |

LIST OF FIGURES

Contd.

| <u>FIGURE</u> <u>No.</u> | <u>TITLE</u> |
|-----------------------------|--|
| IV-C-1 | Flow Diagram, Gas Purification Palladium Diffusion, No Prior Carbon Dioxide or Water Removal |
| IV-C-2 | Change In Number of Cells Required with Hydrogen Recovery for Various Hydrogen Feed Purities. |
| IV-C-3 | Flow Diagram, Gas Purification Palladium Diffusion, Prior Water Removal |
| IV-C-4 | Flow Diagram, Gas Purification Palladium Diffusion, Prior Carbon Dioxide and Water Removal. |
| IV-D | Flow Diagram, Gas Purification, Low Temperature Methanol Scrubbing |
| IV-E | Flow Diagram, Gas Purification, Low Temperature Adsorption |
| IV-F | Flow Diagram, Gas Purification, Standard Girbotol and Methanation |
| V-A-1 | Process Flow Diagram, Hydrogen Generator for Fuel Cell |
| V-B-1 | Temperature - Heat Load Diagram |
| V-B-2 | Effect of Production Rate on Raw Material Consumption |
| V-C-1 | Engineering Drawing, Methanator |
| V-C-2 | Engineering Drawing, Saturator |
| V-C-3 | Engineering Drawing, Feed Vaporizer |
| V-C-4 | Engineering Drawing, Reformer |
| V-C-5 | Engineering Drawing, Separator |
| V-C-6 | Plan View, Hydrogen Generator |
| V-C-7 | Elevation, Hydrogen Generator |
| V-C-8 | Isometric View, Hydrogen Generator |

I. SUMMARY

The Bureau of Ships of the United States Navy contracted with the Girdler Corporation to prepare a design for the manufacture of hydrogen for fuel cell application aboard submarines using methanol as the raw material. Girdler's experience in the development, design, and manufacture of small scale processing plants for portable and submarine use as well as experimental know-how in the synthesis gas generation and purification field was used as the basis for the initial studies. As an aid in studying and evaluating the process problems, a number of general thermodynamic calculations were made and charts constructed. These should prove useful in future phases of the methanol program.

~~As part of this assignment~~ a number of routes were ^{also} investigated. Considering the state-of-the-art and the particular requirements of the submarine application, the evaluation led to the proposed processing sequence. The process consists essentially of the following steps: ↑

1. Pumping and vaporizing liquid methanol, condensate, and oxygen.
2. Catalytic reforming of steam and methanol with provision for direct oxygen injection into the reaction zone.
3. Directly feeding the crude hydrogen to a palladium diffusion unit for purification.
4. Passing through a methanator to guard against possible carbon monoxide leakage.
5. Cooling and saturating the product hydrogen.
6. Burning the purge gas with oxygen in the feed preheater under pressure and disposing of the flue gas directly to the sea after condensing out the water.

Some of the specific advantages of the present design are as follows:

1. Minimum maintenance is required making 10 days of continuous operation easily attainable.
2. Compact design is readily adaptable to the 58C hull design.
3. Major pieces of equipment either fit through a 25" diameter hatch or can be constructed on board.
4. Heat loss is minimized by enclosing the high temperature reactors and the palladium diffusers in a common insulated box.

I. SUMMARY - contd.

5. Sound generation is minimized by reducing requirements for moving equipment.
6. Response time for startup, shutdown, and change of rate is very rapid.
7. Oxygen injection in the reaction zone gives an assist in the acceleration characteristics of the unit.
8. The proposed design lends itself to scale up to large capacities without penalty.
9. Hydrogen inventory is kept within tolerable limits.
10. There is the alternative of condensing and storing the CO₂ in the flue gas.
11. Requires no solutions or storage of other chemicals for operation of the unit.
12. The unit does not generate extraneous material which would contaminate the submarine atmosphere or result in a disposal problem.
13. The design can be fully automated and lends itself to anticipatory computer control for advantageous response characteristics.
14. The unit can be operated on air with little loss in efficiency with addition of air compression.
15. Methanol requirements can be reduced by substitution of diesel oil or other fuels for part of the firing duty.

Methanol as a raw material for generating hydrogen on board submarines has very many advantages over other materials such as diesel oil, jet fuel, or ammonia. Methanol is a relatively pure chemical, widely available and easily stored and handled. The process problems are relatively well known with reasonably satisfactory solutions. Methanol does not give rise to undesirable by-products which would result in difficult disposal problem on the submarine. There is reason to believe that ethanol could be easily substituted for methanol.

In preparing the present design a number of uncertainties were encountered which require experimental verification. Some of these involve process problems which can best be studied in a bench scale or small pilot plant

I. SUMMARY - contd.

set-up. Others involve equipment and control problems which can best be studied in a prototype unit.

Two approaches are proposed for the second phase of the program.

1. Carry out bench scale program before going to prototype unit.
2. Carry out bench scale and prototype programs simultaneously.

The first approach is recommended as the most rational and to be preferred unless time schedules are overriding in which case the second route should be considered.

II. INTRODUCTION:

During the past few years increased interest has been shown in the use of fuel cells as a means of converting fuel to energy. As yet the fuel cell technology has not developed to the point of using directly a raw fuel such as gasoline or fuel oil. These fuels are used only as a raw material source of a highly purified converted fuel, usually hydrogen.

The conversion of these fuels into hydrogen and its purification involve complex chemical reactions and processes. The design and operation of the equipment for this fuel conversion is further complicated by the need of variable rate production or the inclusion of an extensive hydrogen storage facility. Efficient design of the hydrogen production facilities is of the highest importance as the overall attractiveness of fuel cells is dependent upon an efficient source of fuel.

The sources of hydrogen are many and varied. Much commercial experience has been gained over the years in converting these sources to hydrogen for other uses. However, the same experience can be called on in manufacturing hydrogen for fuel cell use. Some of the more commonly used sources are natural gas and petroleum oils, while during World War II methanol was used to some extent.

In looking for new sources of power for submarines the Bureau of Ships, United States Navy, quite naturally became interested in the fuel cell. Besides the high efficiencies attributed to fuel cells other advantages become quite apparent. A fuel cell has quick response together with a relatively high turndown ratio. If hydrogen is the fuel the by-product is water, a material very easily disposed of should the quantity become excessive. The operation of a fuel cell is quiet and the power is produced in a readily usable form.

Because of these advantages the Navy started a search for a source of fuel for the cells. The high inflammability and supply problems made storage and use of pure hydrogen as the primary fuel unattractive. Another factor ruling against pure hydrogen is that considerably more energy is available in the hydrocarbon fuels than in pure hydrogen when based on volume. With hydrogen eliminated as the fuel to be carried on board the submarines some means of hydrogen production had to be developed. Various readily available fuels were chosen as possible fuels and several means of producing hydrogen from each of these fuels were deemed feasible.

The Bureau of Ships of the United States Navy, contracted with the Girdler Corporation (Nobs 86743) (Project Serial No. SF013-06-04, Task 4377) to study the various means of producing hydrogen from methanol suitable for use in a fuel cell. Because of the many ways that hydrogen could be produced from methanol it was necessary to define the limitations that would

II. INTRODUCTION - contd.

be imposed upon the process. The plant was to be designed with a maximum capacity of 70 lbs/hr. of hydrogen of sufficient purity for use in fuel cells. The minimum capacity was to be 4 lbs/hr. and the normal operating rate was to be 20 lbs/hr. The plant was to have minimum response time to changes in demand. It was to operate without down time for 10 days and at the maximum rate for 10 hours in 2 hour periods. Cooling water (salt free) at 95°F. and cryogenic oxygen cooling from the amount of oxygen needed to generate the hydrogen and consume it in the fuel cell was to be available. The system optimization was to be based on minimum weight and volume, high overall efficiency, minimum noise, high reliability, minimum hazard, minimum maintenance and cost, minimum oxygen consumption, and minimum gas leakage or purging to atmosphere. The study was to include an enumeration of engineering and chemical assumptions which require verification by laboratory or engineering tests and an evaluation of the times needed for start-up, shutdown, and minimum to maximum operation. Also, to be included were heat and material balances, size and arrangement of equipment, power consumption, fuel storage, and piping and instrumentation. The raw materials to be used were liquid methanol at pressures equivalent to the submergence depth, liquid oxygen with 0.5% Argon, and condensate from a sump at atmospheric pressure. The product hydrogen was to be delivered at essentially atmospheric pressure, 140°F., and saturated with water. The amount of impurity is not critical since some purging from the fuel cell can be tolerated but CO and H₂S are known to be poisons for certain fuel cell catalysts. CO₂ tends to neutralize an alkaline fuel cell medium although some can be tolerated in a fuel cell using an acid medium. It should be emphasized that the three most important design considerations were compactness, rapid response to changes in output demand and safety. In connection with safety, a hydrogen inventory of less than 900 SCF was considered desirable so as to limit the danger of explosive mixtures in the submarine in case of severe equipment failure.

With the above specifications as a guide the Girdler Corporation first studied the equilibrium and thermodynamic considerations governing various methods of producing hydrogen from methanol. From these results several schemes for the generation and purification cycles were evaluated. The evaluation was made keeping in mind the above factors and the overall efficiency of the scheme. A final scheme was selected and preliminary designs of equipment and auxiliaries were prepared. Complete energy and material balances were calculated and the equipment volumes and weights and the operating requirements were determined.

In the examination of this report it must be kept in mind that the design contained herein is not completely engineered. Laboratory and pilot plant work needed to complete the engineering design was beyond the scope of the contract and was not considered a part of this study. Factors that require further testing or design refinement are discussed in Section VII.

III. GENERAL REVIEW OF HYDROGEN PRODUCTION FROM METHANOL:

A. General Discussion

1. Generation

The use of methanol for the production of hydrogen can be accomplished by several means. Of all these methods reforming, adiabatic reaction, and thermal or catalytic cracking are of major concern and are discussed below.

a. Reforming

By reforming is meant a series of reactions in which the methanol in the presence of steam is catalytically converted to hydrogen, water, carbon monoxide and carbon dioxide. This conversion is usually accomplished at temperatures in excess of 500°F. The reaction is usually carried out in catalyst filled reformer tubes located in a combustion chamber. The heat for the reaction is supplied by the combustion of fuel and is transferred through the tube wall. The composition of the products formed is dependent upon the steam to methanol ratio in the reactants, temperature, pressure, type of catalyst employed, and the length of time the reactants are at temperature and over the catalyst. The overall stoichiometry of the reaction may be represented by the following two equations:

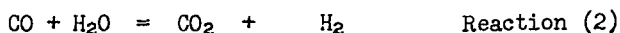
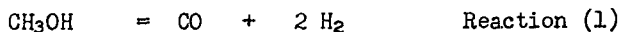

Because the net reaction is endothermic large quantities of heat must be supplied. Undesirable side reactions include the formation of methane and carbon. These reactions can be minimized by choice of catalyst and operating conditions.

b. Adiabatic Reaction

Adiabatic reaction refers to the reaction taking place over a catalyst without heat being added directly to the reactants. The energy needed for the reactions, which are governed by the same equations as given under reforming above, is supplied by either sufficient sensible heat in the reactants or by the addition of oxygen to the

III. GENERAL REVIEW OF HYDROGEN PRODUCTION FROM METHANOL - contd.

reactants upon entering the reactor. In the latter case, the quantity of oxygen is not sufficient for the complete combustion of the methanol present. The heat generated by the partial oxidation of methanol heats the reactants to a point that upon cooling the reactants give up the heat necessary for the endothermic reactions. The proportions of the products produced are controlled by the ratio of oxygen to methanol, the ratio of steam to methanol, and the degree of feed preheat. The heat generated in this system goes directly to the reactants, requiring no transfer across tubes and resulting theoretically in more efficient use of fuel. One major drawback to this system is the fact that the combustion products, carbon dioxide and water, remain in the product gas and increase the purification duty. Another is the problem of setting up a suitable set of catalyst beds to promote the oxidation reaction as well as the reforming routine. From a theoretical standpoint the oxidation reaction can be carried out externally and the hot flue gases added to the rest of the reactants and poured over the catalyst but the equipment becomes more complex.

c. Thermal and Catalytic Cracking

Strictly thermal cracking is subject to extensive carbon deposition. Carbon removal would cause much down time with a subsequent low efficiency. Catalytic decomposition of methanol to carbon monoxide and hydrogen can be carried out successfully. However, it is expedient to obtain additional hydrogen by conversion of the carbon monoxide with steam as in the reforming reaction. Neither of these methods are deemed feasible for this present application.

2. Purification

Three compounds constitute the bulk of the impurities formed with the hydrogen produced by either the reforming or partial oxidation processes. They are carbon monoxide, carbon dioxide, and water. The bulk of the carbon monoxide is removed by the water gas shift reaction shown in Reaction (2). However, for fuel cell applications hydrogen of approximately 99+% purity is desired. For further purification additional steps are required. The methods described below are but a few of the possible systems that can be employed.

III. GENERAL REVIEW OF HYDROGEN PRODUCTION FROM METHANOL - contd.

a. Carbon Dioxide Removal

Experience has shown that many systems are practicable for the removal of carbon dioxide. Aqueous solutions of the ethanolamines have proven to be effective for carbon dioxide removal down to very small quantities. Higher energy requirements for regeneration of the solutions are a detriment. Potassium carbonate solutions, particularly with organic or inorganic additives, are very efficient for bulk carbon dioxide removal. Excellent purification can be obtained by this system but at considerable increase in cost. Low temperature systems with methanol scrubbing or in conjunction with molecular sieves (solid adsorbent and chemical conversion systems (methanation) are other means.

b. Carbon Monoxide Removal

Because of the need for compactness of equipment, carbon monoxide removal by several of the more conventional means (multiple stage carbon monoxide conversion, Cu-liquor solution absorption, etc.) is not applicable. Methanation is an effective means of removing small quantities of carbon monoxide but it adds methane to the product and reduces the yield of hydrogen. However, if the efficiency of the catalyst used for producing the hydrogen is great, the amount of carbon monoxide in the product will be small enough for methanation to be practicable.

The most efficient means for the separation of hydrogen from the impurities listed is diffusion through palladium. This system has rapid response to changes of rate, has a high turndown ratio, and is relatively compact. It does require that the impure hydrogen be at high pressure (200 psi or greater) and that certain palladium poisons be absent.

Various purification schemes were studied keeping in mind the conditions for use as described above. The advantages and disadvantages of each were considered. The results are contained and discussed in Section IV.

III. GENERAL REVIEW OF HYDROGEN PRODUCTION FROM METHANOL - contd.

B. Review of Catalyst information

Many catalysts for the production of hydrogen by reforming hydrocarbons have been developed over the years. Because of the ample supplies and relative low cost of petroleum products most of the reforming catalysts have been for these materials. Little interest has been shown in the use of methanol as a source of hydrogen. One exception to this was during World War II when the U.S. Army showed interest in using methanol as a fuel for small portable hydrogen plants. The Girdler Corporation did some laboratory work at that time in search of an efficient catalyst for this reaction. Many types of catalyst formulations were tried, some showing considerable promise. The summary below contains results on some of the catalyst formulations tested. Much of this earlier work is tabulated in Table III-1.

1. A catalyst consisting of 50% Cu-50% Mn was prepared from the sulfates of the metals. It gave a high yield at temperatures as low as 480°F. and produced only small concentrations of impurities. It could be compressed into hard pellets with ease with only a slight loss in activity. This catalyst had a strong dehydrogenating activity on pure methanol, decomposing it almost completely according to the reaction:

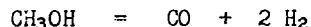

2. Catalyst of varying amounts of copper and iron were tested experimentally at temperatures of 660°F. Compositions from 25 Cu-75 Fe to 75 Cu-25 Fe were reported to give extremely low impurities.

3. Catalysts containing iron, nickel and either copper or chromium were found to promote the reaction $\text{CH}_3\text{OH} = 2 \text{H}_2 + \text{CO}$. The nickel containing catalysts of this series tended to yield more unsaturated hydrocarbons than some others.

4. Methanol was successfully reformed using a combination of Girdler catalysts in a single reaction. The steam ratio was varied from 1.25 to 2.97 giving yields of 98.5% to 99%.

The catalyst used in the production of 27 mobile hydrogen plants built by Girdler Corporation for the U.S. Army was the E.I. DuPont catalyst GCN. Inquiries have

III. GENERAL REVIEW OF HYDROGEN PRODUCTION FROM METHANOL - contd.

revealed that this catalyst is not now in production. A survey of catalyst manufacturers indicate that there are a number of catalyst formulations that may be satisfactory. Experimental work in Girdler laboratories on a number of presently available catalysts indicates this to be the case.

It is interesting to note that at the time of development of the process for the portable Army units the purity of the methanol ranged from 90 to 100%. Evidence was gathered indicating the performance of the catalyst to be dependent upon the purity of the methanol used. The purity of methanol commercially available now is 99.85%. Some of the more common physical properties of this methanol are summarized in Section III-D.

C. Equilibrium Study and Thermodynamic Considerations

1. Product Composition

Before a design for the production and purification of hydrogen could be made it was necessary to study the equilibrium of the two reactions:

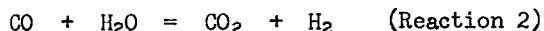

and the thermodynamic characteristics of the various proposed schemes. It was decided that the most practical way for the hydrogen generation was by reforming, adiabatic reaction or some combination of the two. Several factors affecting the product composition were studied and all of these factors could be varied by changing the operating conditions. The three important variables were steam to methanol ratio, preheat temperature, and reaction temperature.

a. Adiabatic Reaction

For the adiabatic reaction study it was necessary to add oxygen to the steam-methanol feed mixture in quantities to supply sufficient heat by combustion to balance the heat requirements. The heat load depended upon the preheat and reaction temperatures. The system was in

III. GENERAL REVIEW OF HYDROGEN PRODUCTION FROM METHANOL - contd.

effect a partial oxidation reaction with various quantities of steam added to effect a miscellaneous shift of CO to the H₂ and CO₂ in a catalytic reactor. In order to determine the amounts of products to be expected, the thermodynamic characteristics of the reaction were reviewed. From a study of the literature it was seen that the reaction temperature would most likely be between 400°F. and 800°F. Calculations were then based on reaction temperatures of 400°F., 600°F., and 800°F. with feed gas temperatures from 100°F. to 600°F. The molal steam to methanol ratio, was varied from 0 to 8.

To determine the equilibrium compositions at the various conditions it was first necessary to assume an amount of oxygen in the feed, the steam to methanol ratio and reaction temperature. The thermodynamic equilibrium and rate of Reaction (1) were assumed sufficient to carry it to completion. The overall equilibrium, therefore, was determined by a material balance and the equilibrium of Reaction (2). The equilibrium constant equation,

$$K = \frac{\text{CO}_2 \times \text{H}_2}{\text{CO} \times \text{H}_2\text{O}}$$

(K being for a specific reaction temperature) was solved to determine the final product composition. Assuming an adiabatic reaction a heat balance calculation gave the feed temperature. If the feed temperature was not within the range desired, a new oxygen value was assumed and the calculations were repeated.

The results were plotted as mols of oxygen per mol of methanol vs. the feed preheat temperature. A separate plot for each of the reaction temperatures was made. Straight line parameters for the steam ratio were used (See figures III-1, 3, 5). From these graphs cross plots were made. The oxygen in the feed was plotted against the steam ratio with parameters of feed preheat temperature. Again a separate plot was made for each of the reaction temperatures. (See Figures III-2, 4, 6).

The calculated equilibrium quantities of the products are summarized in graphical form. The quantities are

III. GENERAL REVIEW OF HYDROGEN PRODUCTION FROM METHANOL - contd.

expressed as mols of product per mol of methanol reacted. The results are grouped according to the three reaction temperatures, 400°F., 600°F., and 800°F. The data are presented in two ways: Product vs feed preheat temperature with parameters of steam ratio and product vs. steam ratio with parameters of feed preheat temperature. It is to be noted that the quantities of the products vary greatly with the steam ratio. Therefore, care must be exercised in the use of the graphs as the scale calibration may not be continuous. (See Figures III-C-7 thru III-C-30).

It is noted that the amount of oxygen required is independent of the steam ratio (above 1.0) and the reaction temperature as long as the feed preheat temperature is equal to the reaction temperature. This is explained by the fact that the only heat needed is that for the endothermic reaction. The product curves indicate that from the equilibrium point of view the minimum desirable steam ratio is between 1.0 and 2.0.

Figures III-C-31 shows the variation in the hydrogen production with reaction temperature for a given preheat temperature. It demonstrates graphically that as the reaction temperature increases, the fraction of the methanol used as fuel increases. However, the lower the reaction temperature the lower would be the expected catalyst activity and the lower the methanol conversion.

b. Reforming

The same equations and equilibrium constants, govern the mechanisms whether the reaction takes place in an adiabatic reactor or in a reformer. There would be no oxygen addition to the feed for an ordinary reformer. Therefore, there would be a shift in the ratios of carbon monoxide to carbon dioxide and hydrogen to water in the product. However, this difference is small, and for evaluation purposes the same curves used in the adiabatic partial oxidation studies can be applied. The actual composition of the product is dependent upon the catalyst employed and the approach to equilibrium attained.

In all cases the compositions were based on a 100% approach to equilibrium.

III. GENERAL REVIEW OF HYDROGEN PRODUCTION FROM METHANOL - contd.

2. Enthalpic Considerations

a. Reactor Inlet Temperature

In an adiabatic reactor where the reaction is endothermic it is necessary that the reactants enter the reactor at some elevated temperature and that the heat is supplied from the sensible heat in the reactants. The reaction will proceed and the equilibrium will be established at some temperature lower than the inlet. A number of calculations were made to determine inlet temperatures that would supply the heat needed for the reaction to proceed at the three temperature levels; 400°F., 600°F. and 800°F. The basis for the calculations was the heat of the reaction as given below:

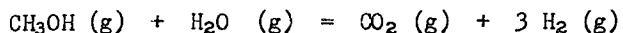

$$\Delta H = 21,300 \text{ BTU/Mol}$$

The reactor inlet temperature was taken as the temperature at which the enthalpy of the reactants was equal to the sum of 21,300 Btu and the enthalpy of the products at the appropriate reactor temperature. The results are summarized in a useful form in Figure, III-C-32. In these calculations no allowance was made for heat loss from the reactor.

b. Heat Input Requirements

In the case of endothermic reactions it is obvious that a source of heat energy is needed. The source of this energy can be the combustion of a fuel, electric power, or high level waste heat from some other process. In the application being considered no waste heat is available. Likewise, since the ultimate use of the hydrogen is the production of electrical power in the fuel cell the source of heat should be other than electricity. The combustion of methanol with oxygen was therefore selected as the source of high temperature heat. The amount of heat required is dependent upon the steam ratio and the reactor exit temperature. The total heat load can be broken into two

III. GENERAL REVIEW OF HYDROGEN PRODUCTION FROM METHANOL - contd.

parts, preheat requirements and reaction heat requirements. The liquid feed (CH_3OH and water assumed at 60°F .) must be heated to the boiling point, vaporized, and then superheated to the reactor inlet temperature.

In Figure III-C-33 are summarized the preheat requirements in thousands of BTU/Mol of methanol needed to convert the liquid methanol and water at 60°F . to superheated vapor at the various preheat temperatures. As would be expected the preheat requirement is a direct proportion to the steam ratio. Figures III-C-34, 35, and 36 contain the reaction heat requirements of converting the $\text{CH}_3\text{OH-H}_2\text{O}$ mixtures at different preheat temperatures to product at the reactor exit temperature. The total heat requirement for the various steam ratios is contained in Figure III-C-37.

c. Flame Temperature

In the use of a direct fired reactor or heater care must be taken to keep the flame temperature within the design limits. If the flame temperature becomes excessive there is danger of exceeding the limitation of materials and damaging equipment. In the case of using pure oxygen rather than air as the oxidant, the flame temperature becomes much higher because there is no nitrogen present to act as a diluent. In the present design water is added to the combustion mixture to act as a substitute for nitrogen. In the combustion process the water is vaporized and superheated and therefore absorbs both latent heat and sensible heat. Figure III-C-38 presents data on the flame temperature with various steam ratios and preheat temperatures. It should be noted that no correction was used for the disassociation of CO_2 and H_2O at temperatures above 3000°F . In general the disassociation would have some temperature lowering effect. This effect is not deemed sufficient for consideration in this study.

D. Physical and Thermodynamic Properties

In Table III-2 are summarized the physical properties of methanol. It was obtained from the brochures of methanol manufacturers and

III. GENERAL REVIEW OF HYDROGEN PRODUCTION FROM METHANOL - contd.

is descriptive of the methanol presently available in large quantities.

The vapor pressure of methanol, water, and a 2.0:1 steam to methanol mixture is presented in Figure III-D-1. The 2.0:1 steam ratio was treated as an ideal solution. This curve may be in some error because of the non-ideal nature of methanol-water solutions but the error is believed to be small.

Tables III-3 through III-9 contain the absolute enthalpies above the elements, heat capacities, and logarithms of the equilibrium constants of formation of the major constituents involved in the production of hydrogen from methanol. Table III-10 contains the equilibrium constants and heats of reactions for the water gas shift: $\text{CO} + \text{H}_2\text{O} = \text{CO}_2 + \text{H}_2$.

These data are presented in this report in order to make available in a convenient form the data which are the basis of process calculations developed in the present study (Contract Nobs 86743). The major part of the information is taken from publications by the National Bureau of Standards. Suitable interpolations were made so that the Fahrenheit temperature scale could be used. The data have been critically evaluated and are believed to be the most accurate data available pertaining to the respective chemical species and reactions described. The data were extracted from a larger compilation made in 1954 by the Gas Processes Division of The Girdler Company, an antecedent of the Girdler Corporation.

TABLE III-1
SUMMARY OF CATALYST RESULTS (1)

| CATALYST COMPOSITION: | Temp. °F. | % H ₂ | % CO | % CO ₂ | % CH ₄ | % O ₂ | % N ₂ | % Unsat. | % Sat. | % Yield |
|-----------------------|-----------|------------------|------|-------------------|-------------------|------------------|------------------|----------|--------|---------|
| GCN (DuPont) | 480 | 74.7 | 1.2 | 24.1 | - | 0.18 | 1.84 | 0.00 | 0.27 | 100 |
| 50 Cu - 50 Mn | 570 | 73.18 | 0.86 | 24.03 | - | 0.00 | - | 0.00 | - | - |
| 20 Cu-5 Cr-75Zn | 660 | 75.10 | 0.90 | 24.00 | 0.00 | 0.25 | - | 0.71 | - | - |
| 45 Cu-10 Ni-45 Fe | 660 | 73.44 | 2.22 | 23.35 | 0.25 | 0.151 | - | 0.00 | - | - |
| 33 Cu-67 Cr | 660 | 75.62 | 1.81 | 23.46 | 0.05 | 1.2 | - | 0.67 | - | - |
| 55 Cu - 45 Co | 660 | 75.11 | 2.44 | 22.55 | 0.25 | 0.33 | - | 0.00 | - | 100 |
| 35 Cu - 65 Mn | 570 | 73.28 | 1.72 | 23.11 | 0.00 | 0.25 | - | 0.40 | 0.00 | 100 |
| 75 Cu - 25 Fe | 660 | 74.92 | 0.29 | 24.79 | - | 0.0 | 0.0 | 0.40 | 0.00 | 100 |
| 70 Fe - 20 Ni - 10 Cr | 660 | 74.80 | 1.10 | 23.80 | - | 0.0 | 0.0 | 0.60 | 0.00 | 95 |
| 70 Fe - 20 Ni - 10 Cr | 660 | 74.40 | 1.10 | 24.05 | - | 0.0 | 0.0 | 0.70 | 0.00 | 100 |
| 75 Fe - 20 Cu - 5 Ni | 660 | 73.90 | 1.10 | 24.40 | - | 0.0 | Inerts - | 0.71 | 0.71 | 100 |
| 75 Fe - 20 Cu - 5 Ni | 660 | 72.35 | 1.35 | 24.35 | - | 0.2 | 1.2 | 0.25 | 0.00 | 100 |
| 75 Fe - 20 Cu - 10 Ni | 660 | 73.44 | 2.20 | 23.35 | - | 0.20 | - | 0.37 | 0.00 | 98.5 |
| 45 Fe - 45 Cu - 10 Ni | 660 | 75.22 | 1.82 | 23.68 | - | 0.2 | 0.9 | 0.00 | 0.4 | 99.0 |
| 85 Fe - 10 Cr - 5 Ni | 1200 | 71.0 | 10.7 | 16.8 | - | 0.2 | 0.9 | 0.0 | 0.5 | |
| 25B, 25C, 50F-5 (2) | 1200 | 69.2 | 18.3 | 10.9 | - | 0.2 | 0.9 | 0.0 | 0.5 | |
| 25B, 25C, 50F-5 (2) | 1200 | | | | - | | | | | |

Contd.

TABLE III-1 - contd.

NOTES:

- (1) The values shown for percentage composition are "as-reported" results from actual analytical tests by the Orsat method, are uncorrected and not adjusted to the air-free basis. Since there was no free or combined nitrogen in the reactants there would be no nitrogen (N_2) in the reaction products from these reactants. In the Orsat method, nitrogen is reported as the difference between the summation of all other constituents which are analyzable and one hundred per cent. Therefore, the values reported in the table under % N_2 or inerts represents either the accumulated errors in analysis or air leakage into the gas sample. Likewise the values reported for % O_2 are believed to represent air leakage into the gas sample.
- (2) The designations "B", "C", "WF-5" for the last two compositions of catalyst in the table represent proprietary compositions of catalysts that had been used primarily as catalyst in the steam-hydrocarbon reforming process for production of hydrogen.

TABLE III-2-1

PHYSICAL PROPERTIES OF METHANOL

| | |
|---|----------------------|
| Boiling Point at 760 mm Hg | 148°F. |
| Critical Pressure | 78.59 Atm. |
| Critical Temperature | 464°F. |
| Density of Liquid at 59°F. | 0.79609 g/ml. |
| 68°F. | 0.79140 |
| 77°F. | 0.78674 |
| Explosive Limits, in Air | 6.0 to 36.5% by Vol. |
| Flash Point, Tag Open Cup | 60°F. |
| Tag Closed Cup | 54°F. |
| Freezing Point | -144°F. |
| Heat Capacity, Cp Liquid, 32°F. | 0.566 Btu/Lb.°F. |
| 77°F. | 0.600 Btu/Lb.°F. |
| Heat of Combustion (liq) CO ₂ (g) & H ₂ O (g) | -274,700 Btu/Lb.Mol |
| Heat of Formation (liq) | -102,665 Btu/Lb.Mol |
| Molecular Weight | 32.042 |
| Refractive Index at | 1.33118 |
| 77°F. | 1.32663 |
| Viscosity at 32°F. | 0.82 Cp |
| 68°F. | 0.597 Cp |
| 86°F. | 0.510 Cp |

TABLE III-2-2

SPECIFICATIONS FOR METHANOL

| | |
|--|---|
| Purity, Minimum | 99.85% w |
| Specific Gravity, Maximum, at 20°/20°C | 0.79268 |
| 25°/25°C | 0.7889 |
| Acidity as Acetic Acid, Maximum | 0.003% |
| Acetone, Maximum | 0.003% |
| Alkalinity as Ammonia, Maximum | 0.0003% |
| Distillation Range, Maximum | 1.0°C including 64.5°C. |
| Non-volatile Matter, Maximum | 0.0010 g/100 ml |
| Water, Maximum | 0.1% |
| Color, Maximum | 5 APHA |
| Permanganate Time, Minimum | 50 Minutes at 15°C. |
| Carbonizable Substances,* Maximum | 50 APHA |
| Chloride | Free of Turbidity in Standard Chloride Test |
| Sulfur | Free of Discoloration in Standard Sulfur Test |
| Appearance | Clear and Free from Suspended Matter |
| Odor | Characteristic, Free from Foreign Odor, Non- residual |
| Water Solubility | No Turbidity After One Hour at 25°C. when One Volume of Methanol is Diluted with Three Volumes of Distilled Water |

*Sulfuric Acid Wash Test

TABLE III-3

ENTHALPY AND PHYSICAL PROPERTIES OF OXYGEN (Gas) O₂

Mol. wt = 32.000
 bp = -297.4°F
 mp = -361.8°F*

d(l) = 71.2 lb/cu ft
 at -297.4°F
 T_c = -181.8°F
 P_c = 730.4 psia

| Temp., °F | H° - H° ₀ Btu/lb mole | C _p °, Btu/lb mole °F |
|--------------|-------------------------------------|-------------------------------------|
| 32 | 3,410 | 6.989 |
| 60 | 3,607 | 7.004 |
| 77 | 3,726 | 7.017 |
| 100 | 3,887 | 7.035 |
| 200 | 4,591 | 7.129 |
| 300 | 5,313 | 7.246 |
| 400 | 6,045 | 7.376 |
| 500 | 6,790 | 7.512 |
| 600 | 7,547 | 7.644 |
| 700 | 8,318 | 7.771 |
| 800 | 9,101 | 7.885 |
| 900 | 9,894 | 7.988 |
| 1000 | 10,697 | 8.081 |
| 1100 | 11,511 | 8.166 |
| 1200 | 12,332 | 8.241 |
| 1300 | 13,159 | 8.309 |
| 1400 | 13,993 | 8.372 |
| 1500 | 14,832 | 8.429 |
| 1600 | 15,677 | 8.482 |
| 1700 | 16,528 | 8.530 |
| 1800 | 17,384 | 8.574 |
| 1900 | 18,243 | 8.616 |
| 2000 | 19,107 | 8.653 |
| 2100 | 19,974 | 8.690 |
| 2200 | 20,845 | 8.725 |

*Triple Point

TABLE III-4

ENTHALPY AND PHYSICAL PROPERTIES OF HYDROGEN (Gas) H₂

Mol. wt = 2.0160
 bp = -423°F
 mp = -434.6°F*

d(l) = 4.42 lb/cu ft
 at -423°F
 T_c = -400°F
 P_c = 188 psia

| Temp., °F | H° - H° ₀ Btu/lb mole | C _p °, Btu/lb mole°F |
|-----------|-------------------------------------|------------------------------------|
| 32 | 3,334 | 6.834 |
| 60 | 3,526 | 6.871 |
| 77 | 3,643 | 6.887 |
| 100 | 3,802 | 6.905 |
| 200 | 4,496 | 6.953 |
| 300 | 5,193 | 6.977 |
| 400 | 5,891 | 6.987 |
| 500 | 6,590 | 6.993 |
| 600 | 7,289 | 7.002 |
| 700 | 7,991 | 7.014 |
| 800 | 8,694 | 7.030 |
| 900 | 9,400 | 7.052 |
| 1000 | 10,107 | 7.080 |
| 1100 | 10,817 | 7.112 |
| 1200 | 11,530 | 7.151 |
| 1300 | 12,248 | 7.193 |
| 1400 | 12,970 | 7.241 |
| 1500 | 13,697 | 7.292 |
| 1600 | 14,429 | 7.344 |
| 1700 | 15,167 | 7.399 |
| 1800 | 15,911 | 7.455 |
| 1900 | 16,660 | 7.512 |
| 2000 | 17,414 | 7.570 |
| 2100 | 18,174 | 7.629 |
| 2200 | 18,939 | 7.685 |

*Triple Point

TABLE III-5
 ENTHALPY AND PHYSICAL PROPERTIES OF WATER (Gas) H₂O

Mol. wt. = 18.016
 bp = 212°F
 mp = 32°F

d(l) = 62.3 lb/cu ft
 at 68°F
 T_c = 705.4°F
 P_c = 3206 psia

| Temp., °F | H° -H° _o + ΔH _f ° Btu/lb mole | Log ₁₀ K _f | C _p °, Btu/lb Mole °F |
|-----------|--|----------------------------------|-------------------------------------|
| 32 | -98,890 | 43.9218 | 8.001 |
| 60 | -98,667 | 41.4322 | 8.015 |
| 77 | -98,530 | 40.0470 | 8.026 |
| 100 | -98,346 | 38.3051 | 8.039 |
| 200 | -97,538 | 32.1369 | 8.122 |
| 300 | -96,720 | 27.5823 | 8.231 |
| 400 | -95,890 | 24.0794 | 8.359 |
| 500 | -95,048 | 21.3002 | 8.498 |
| 600 | -94,192 | 19.0410 | 8.646 |
| 700 | -93,319 | 17.1669 | 8.799 |
| 800 | -92,431 | 15.5878 | 8.958 |
| 900 | -91,526 | 14.2380 | 9.120 |
| 1000 | -90,612 | 13.0713 | 9.288 |
| 1100 | -89,669 | 12.0520 | 9.456 |
| 1200 | -88,714 | 11.1545 | 9.627 |
| 1300 | -87,741 | 10.3574 | 9.800 |
| 1400 | -86,753 | 9.6453 | 9.971 |
| 1500 | -85,750 | 9.0050 | 10.139 |
| 1600 | -84,727 | 8.4261 | 10.305 |
| 1700 | -83,687 | 7.9003 | 10.467 |
| 1800 | -82,631 | 7.4197 | 10.626 |
| 1900 | -81,562 | 6.9800 | 10.779 |
| 2000 | -80,477 | 6.5758 | 10.928 |
| 2100 | -79,378 | 6.2028 | 11.011 |
| 2200 | -78,264 | 5.8574 | 11.210 |

TABLE III-6

ENTHALPY AND PHYSICAL PROPERTIES OF CARBON MONOXIDE (Gas) CO

Mol. wt = 28.010
 bp = -312.7°F
 mp = -337.1°F*

$d(1) = 50.8$ lb/cu ft
 at -319°F
 $T_c = -218.2$ °F
 $P_c = 514$ psia

| Temp., °F | $H^\circ - H^\circ_{\text{O}} + \Delta H_f^\circ_{\text{O}}$ Btu/lb mole | $\log_{10} K_f$ | C_p° , Btu/lb mole °F |
|-----------|---|-----------------|---------------------------------|
| 32 | -45,546 | 25.8214 | 6.959 |
| 60 | -45,351 | 24.6811 | 6.962 |
| 77 | -45,233 | 24.0479 | 6.965 |
| 100 | -45,073 | 23.2517 | 6.968 |
| 200 | -44,375 | 20.4419 | 6.990 |
| 300 | -43,674 | 18.3757 | 7.032 |
| 400 | -42,968 | 16.7917 | 7.091 |
| 500 | -42,255 | 15.5379 | 7.167 |
| 600 | -41,534 | 14.5200 | 7.256 |
| 700 | -40,804 | 13.6770 | 7.352 |
| 800 | -40,063 | 12.9668 | 7.450 |
| 900 | -39,313 | 12.3590 | 7.548 |
| 1000 | -38,554 | 11.8341 | 7.643 |
| 1100 | -37,784 | 11.3750 | 7.733 |
| 1200 | -37,007 | 10.9707 | 7.820 |
| 1300 | -36,221 | 10.6113 | 7.901 |
| 1400 | -35,427 | 10.2895 | 7.977 |
| 1500 | -34,626 | 9.9997 | 8.044 |
| 1600 | -33,818 | 9.7373 | 8.109 |
| 1700 | -33,004 | 9.4990 | 8.167 |
| 1800 | -32,184 | 9.2800 | 8.223 |
| 1900 | -31,359 | 9.0793 | 8.274 |
| 2000 | -30,529 | 8.8944 | 8.322 |
| 2100 | -29,694 | 8.7236 | 8.366 |
| 2200 | -28,856 | 8.5651 | 8.406 |

*Triple Point

TABLE III-7

ENTHALPY AND PHYSICAL PROPERTIES OF CARBON DIOXIDE (Gas) CO₂

Mol. wt = 44.010
 bp = -109.3°F (sublimes)
 mp = -69.2°F (5.2 atm)

d(1) = 68.7 lb/cu ft
 at -34.6°F
 T_c = 88°F
 P_c = 1073 psia

| Temp., °F | H° - H° ₀ + ΔH _f ° Btu/lb mole | Log ₁₀ K _f | C _p °, Btu/lb mole °F |
|-----------|---|----------------------------------|-------------------------------------|
| 32 | -165,509 | 75.4005 | 8.596 |
| 66 | -165,265 | 71.3461 | 8.768 |
| 77 | -165,115 | 69.0915 | 8.870 |
| 100 | -164,909 | 66.2567 | 9.010 |
| 200 | -163,979 | 56.2342 | 9.565 |
| 300 | -162,997 | 48.8521 | 10.058 |
| 400 | -161,969 | 43.1866 | 10.499 |
| 500 | -160,899 | 38.6999 | 10.891 |
| 600 | -159,792 | 35.0585 | 11.243 |
| 700 | -158,652 | 32.0451 | 11.560 |
| 800 | -157,481 | 29.5103 | 11.846 |
| 900 | -156,283 | 27.3460 | 12.111 |
| 1000 | -155,060 | 25.4793 | 12.344 |
| 1100 | -153,814 | 23.8507 | 12.560 |
| 1200 | -152,550 | 22.4188 | 12.754 |
| 1300 | -151,266 | 21.1483 | 12.930 |
| 1400 | -149,964 | 20.0147 | 13.088 |
| 1500 | -148,648 | 18.9965 | 13.234 |
| 1600 | -147,318 | 18.0768 | 13.366 |
| 1700 | -145,975 | 17.2425 | 13.489 |
| 1800 | -144,618 | 16.4805 | 13.599 |
| 1900 | -143,253 | 15.7840 | 13.701 |
| 2000 | -141,879 | 15.1434 | 13.797 |
| 2100 | -140,492 | 14.5530 | 13.885 |
| 2200 | -139,100 | 14.0072 | 13.960 |

TABLE III-8

ENTHALPY AND PHYSICAL PROPERTIES OF METHANE (Gas) CH₄

Mol. wt = 16.042
 bp = -258.7°F
 mp = -296.5°F*

d(1) = 25.9 lb/cu ft
 at -263.2°F
 T_c = -116.5°F
 P_c = 637 psia

| Temp., °F | H° - H° _o + ΔH _f ° Btu/lb mole | Log ₁₀ K _f | C _p °, Btu/lb mole °F |
|-----------|---|----------------------------------|-------------------------------------|
| 32 | -24,834 | 10.0893 | 8.296 |
| 60 | -24,605 | 9.3263 | 8.440 |
| 77 | -24,462 | 8.8985 | 8.537 |
| 100 | -24,264 | 8.3547 | 8.665 |
| 200 | -23,370 | 6.4122 | 9.306 |
| 300 | -22,402 | 4.9584 | 10.033 |
| 400 | -21,362 | 3.8206 | 10.811 |
| 500 | -20,241 | 2.9006 | 11.604 |
| 600 | -19,041 | 2.1393 | 12.389 |
| 700 | -17,764 | 1.4996 | 13.149 |
| 800 | -16,413 | 0.9543 | 13.877 |
| 900 | -14,991 | 0.4837 | 14.569 |
| 1000 | -13,501 | 0.0726 | 15.227 |
| 1100 | -11,947 | -0.2896 | 15.850 |
| 1200 | -10,331 | -0.6117 | 16.438 |
| 1300 | -8,658 | -0.9002 | 17.000 |
| 1400 | -6,929 | -1.1581 | 17.513 |
| 1500 | -5,163 | -1.3901 | 17.995 |
| 1600 | -3,349 | -1.6008 | 18.444 |
| 1700 | -1,471 | -1.7930 | 18.878 |
| 1800 | 439 | -1.9693 | 19.279 |
| 1900 | 2,397 | -2.1313 | 19.648 |
| 2000 | 4,372 | -2.2799 | 19.985 |
| 2100 | 6,394 | -2.4169 | 20.306 |
| 2200 | 8,434 | -2.5438 | 20.595 |

*Triple Point

TABLE III-9

ENTHALPY AND PHYSICAL PROPERTIES OF METHANOL (Gas) CH₃OH

Mol. wt = 32.042
 bp = 148.5°F
 mp = -144.2°F
 d(1) = 49.4 lb/cu ft at 68°F
 T_c = 464°F
 P_c = 1157 psia

| Temp., °F | H° - H° _o + ΔH _f ° Btu/lb mole | Log ₁₀ K _f | C _p °, Btu/lb mole °F |
|-----------|---|----------------------------------|-------------------------------------|
| 32 | -77,416 | 31.579 | 10.27 |
| 60 | -77,124 | 29.513 | 10.58 |
| 77 | -76,943 | 28.362 | 10.76 |
| 100 | -76,693 | 26.912 | 11.01 |
| 200 | -75,541 | 21.754 | 12.07 |
| 300 | -74,286 | 17.921 | 13.11 |
| 400 | -72,919 | 14.952 | 14.12 |
| 500 | -71,463 | 12.585 | 15.10 |
| 600 | -69,907 | 10.651 | 16.04 |
| 700 | -68,258 | 9.040 | 16.94 |
| 800 | -66,526 | 7.676 | 17.79 |
| 900 | -64,716 | 6.507 | 18.58 |
| 1000 | -62,826 | 5.494 | 19.33 |
| 1100 | -60,866 | 4.607 | 20.03 |
| 1200 | -58,826 | 3.824 | 20.70 |
| 1300 | -56,726 | 3.128 | 21.32 |

TABLE III-10
EQUILIBRIUM CONSTANTS AND HEATS OF REACTION
FOR THE WATER GAS SHIFT REACTION

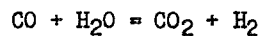

| Temp., °F | ΔH° , Btu/lb mole | K_p |
|-----------|-----------------------------------|--------|
| 200 | -17,570 | 4523 |
| 300 | -17,410 | 783.6 |
| 400 | -17,220 | 206.8 |
| 500 | -17,006 | 72.75 |
| 600 | -16,777 | 31.44 |
| 700 | -16,538 | 15.89 |
| 800 | -16,293 | 9.030 |
| 900 | -16,044 | 5.610 |
| 1000 | -15,787 | 3.749 |
| 1100 | -15,544 | 2.653 |
| 1200 | -15,299 | 1.966 |
| 1300 | -15,056 | 1.512 |
| 1400 | -14,814 | 1.202 |
| 1500 | -14,575 | 0.9813 |
| 1600 | -14,344 | 0.8192 |
| 1700 | -14,117 | 0.6970 |
| 1800 | -13,892 | 0.6037 |
| 1900 | -13,672 | 0.5305 |
| 2000 | -13,459 | 0.4712 |
| 2100 | -13,246 | 0.4233 |
| 2200 | -13,041 | 0.3843 |

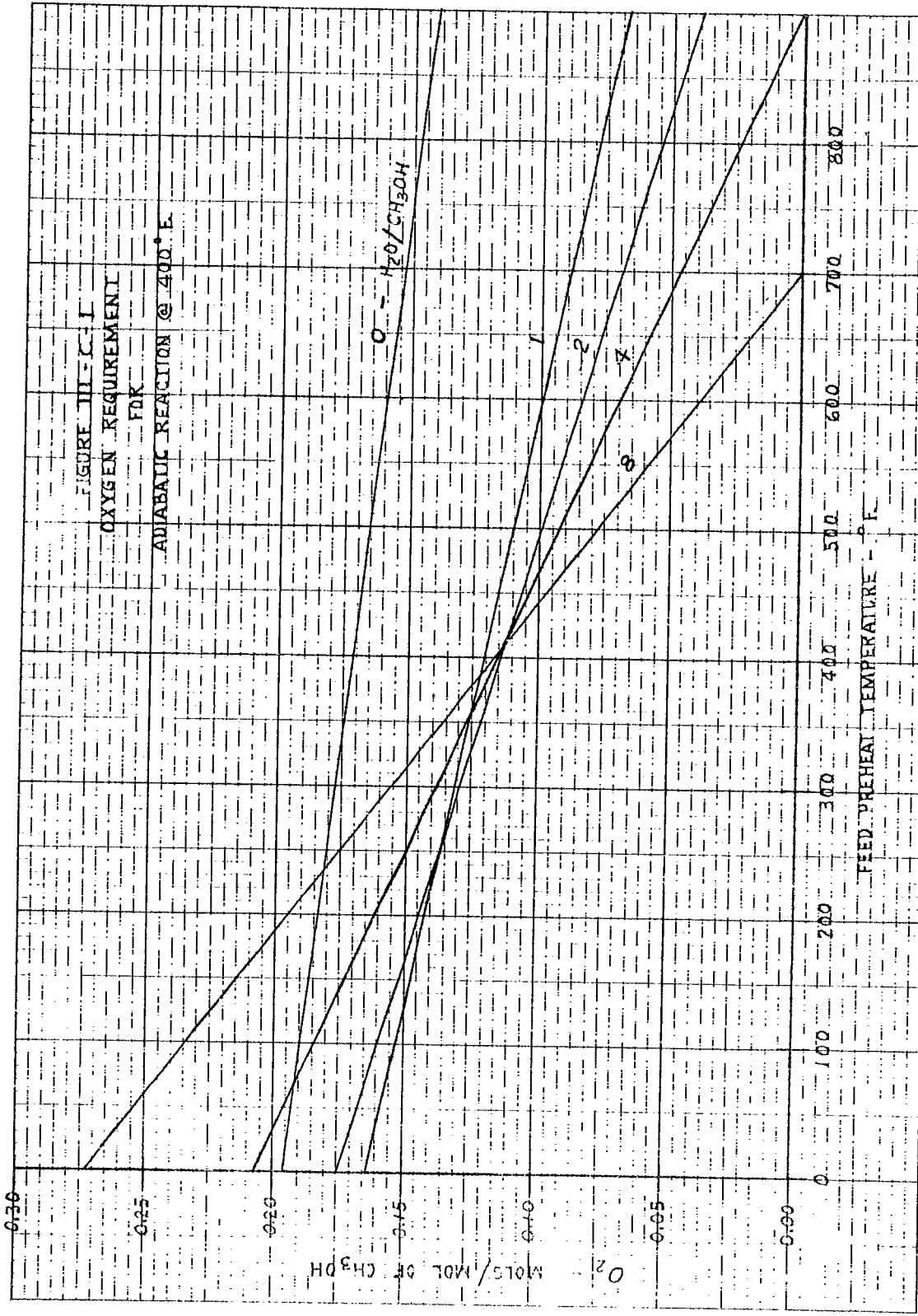

FIGURE III - C - I
 OXYGEN REQUIREMENT
 FDK

ADIABATIC REACTION @ 400°F.

0 - H₂O/CH₃OH

GIRDLER CORPORATION
 LOUISVILLE, KENTUCKY

FOR: BUREAU OF SHIPS
 U. S. NAVY

DRAWING NUMBER
 A-5414-III-C-1

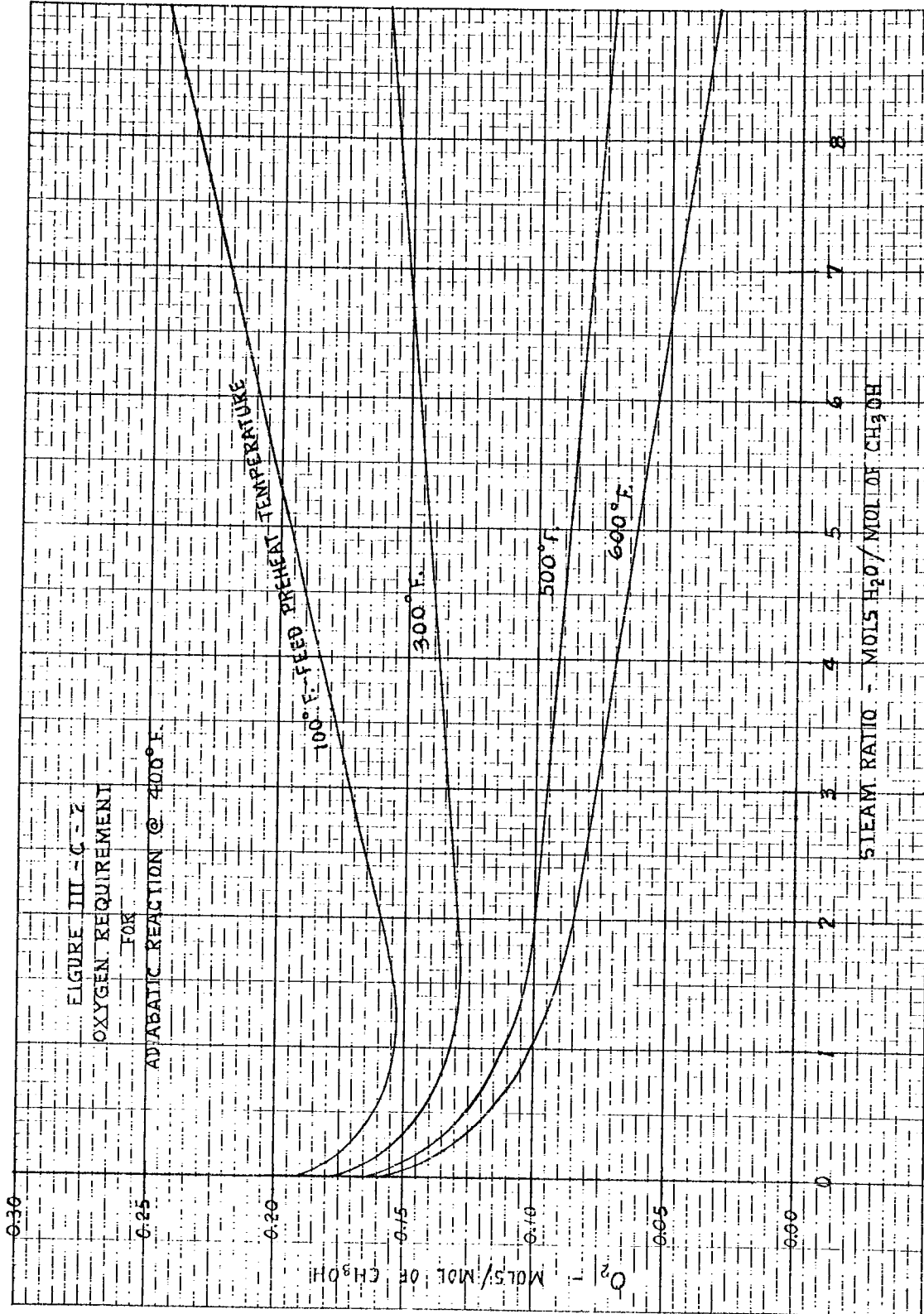

FIGURE III - C - 2
 OXYGEN REQUIREMENT
 FOR

ADIABATIC REACTION @ 400°F.

GIRDLER CORPORATION
 LOUISVILLE, KENTUCKY

FOR: BUREAU OF SHIPS
 U. S. NAVY

DRAWING NUMBER
 A-5414-III-C-2

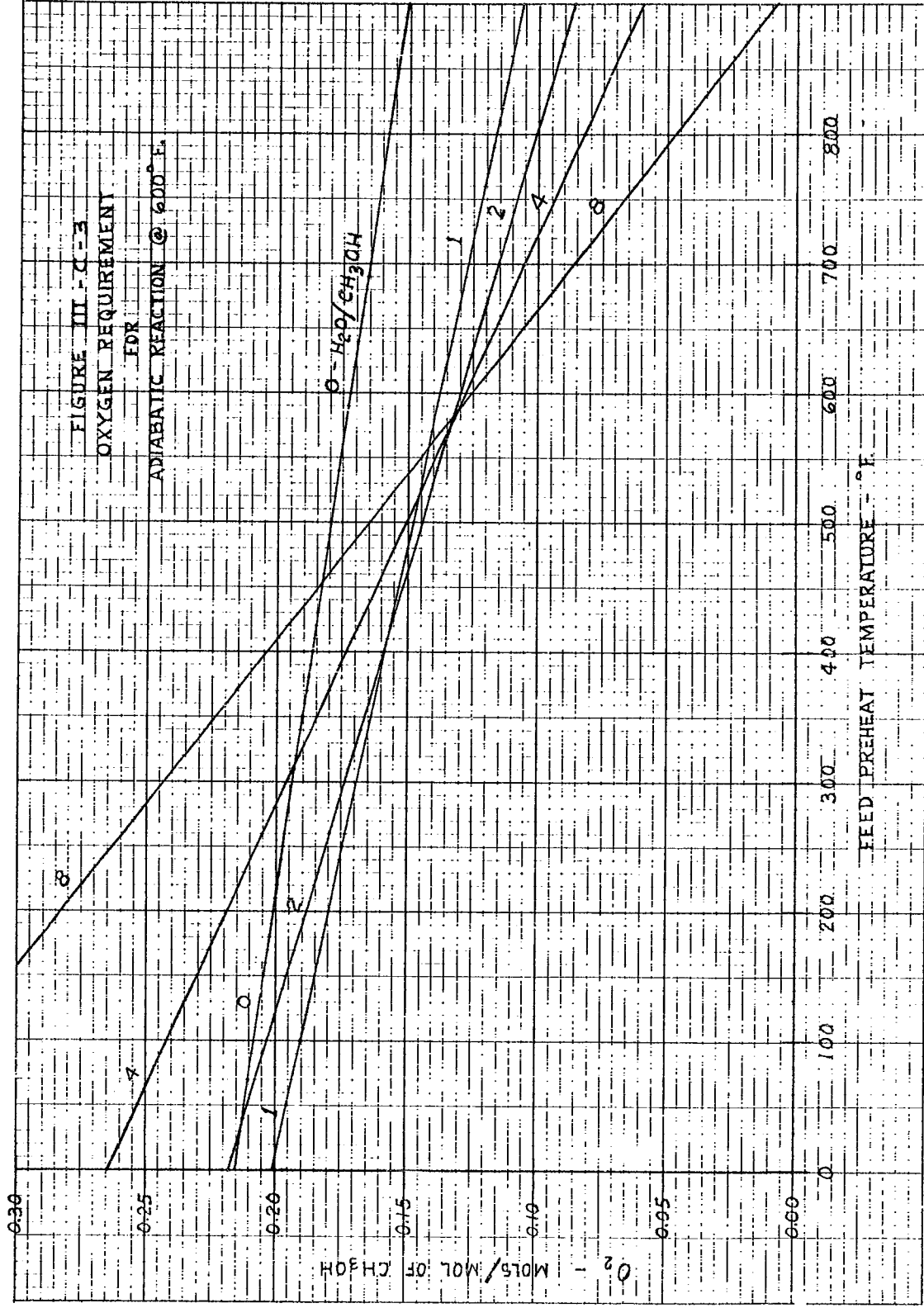

| | |
|---|------------------------------------|
| GIRDLER CORPORATION LOUISVILLE, KENTUCKY | FOR: BUREAU OF SHIPS U. S. NAVY |
| DRAWING NUMBER A-5414-III-C-3 | |

10 X 10 TO THE INCH 359-5DG
 KEMPFL & ESSLER CO. MADE IN U.S.A.

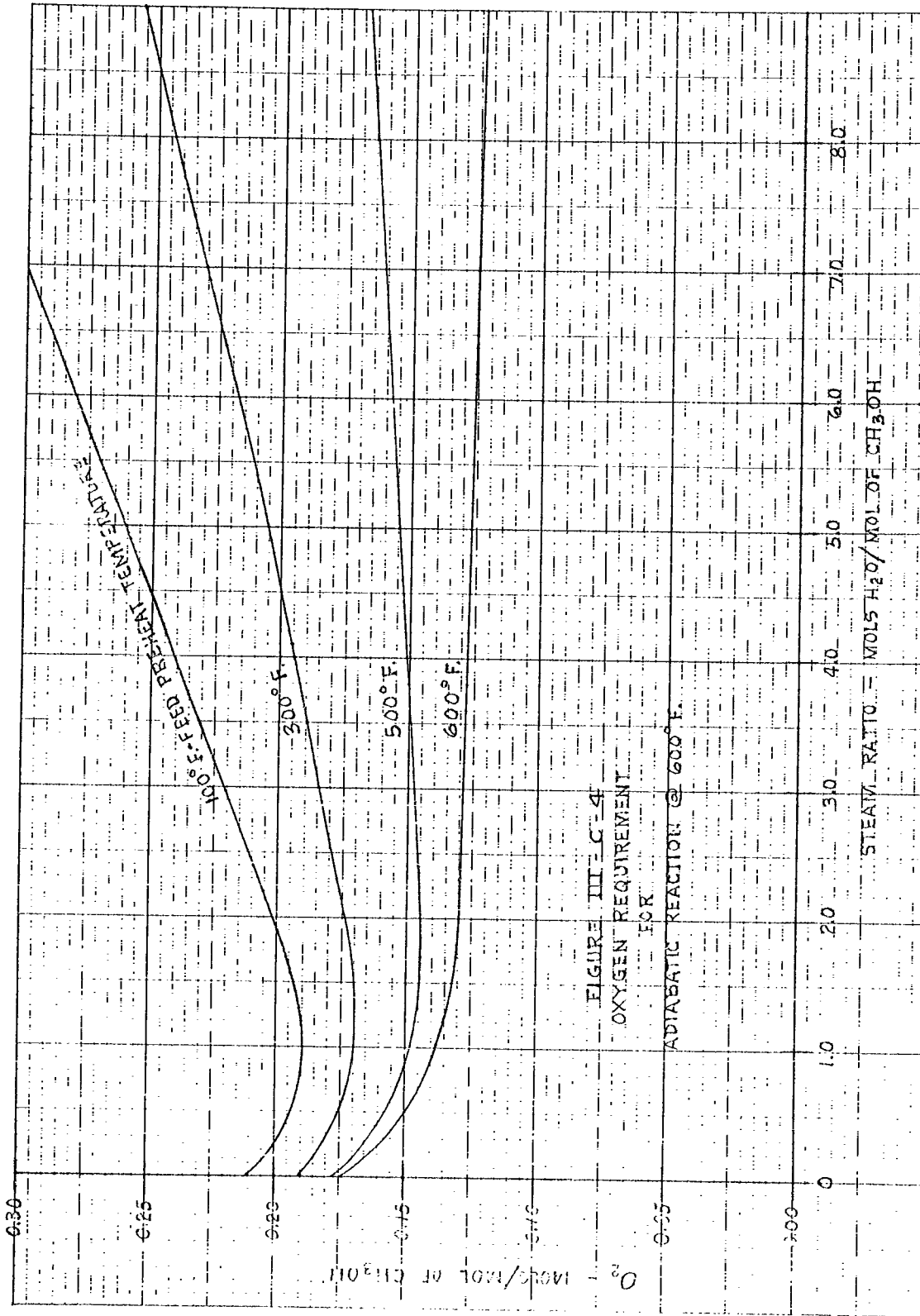

FIGURE III-C-4
 OXYGEN REQUIREMENT
 FOR

ADIABATIC REACTION @ 600°F.

STEAM RATIO = MOLS H₂O/MOL OF CH₃OH

GIRDLER CORPORATION
 LOUISVILLE, KENTUCKY

FOR: BUREAU OF SHIPS
 U. S. NAVY

DRAWING NUMBER
 A-5414-III-C-4

1/2" x 10" TO THE INCH
 KIEFFEL & FISER CO.
 359-5DG
 MADE IN U.S.A.

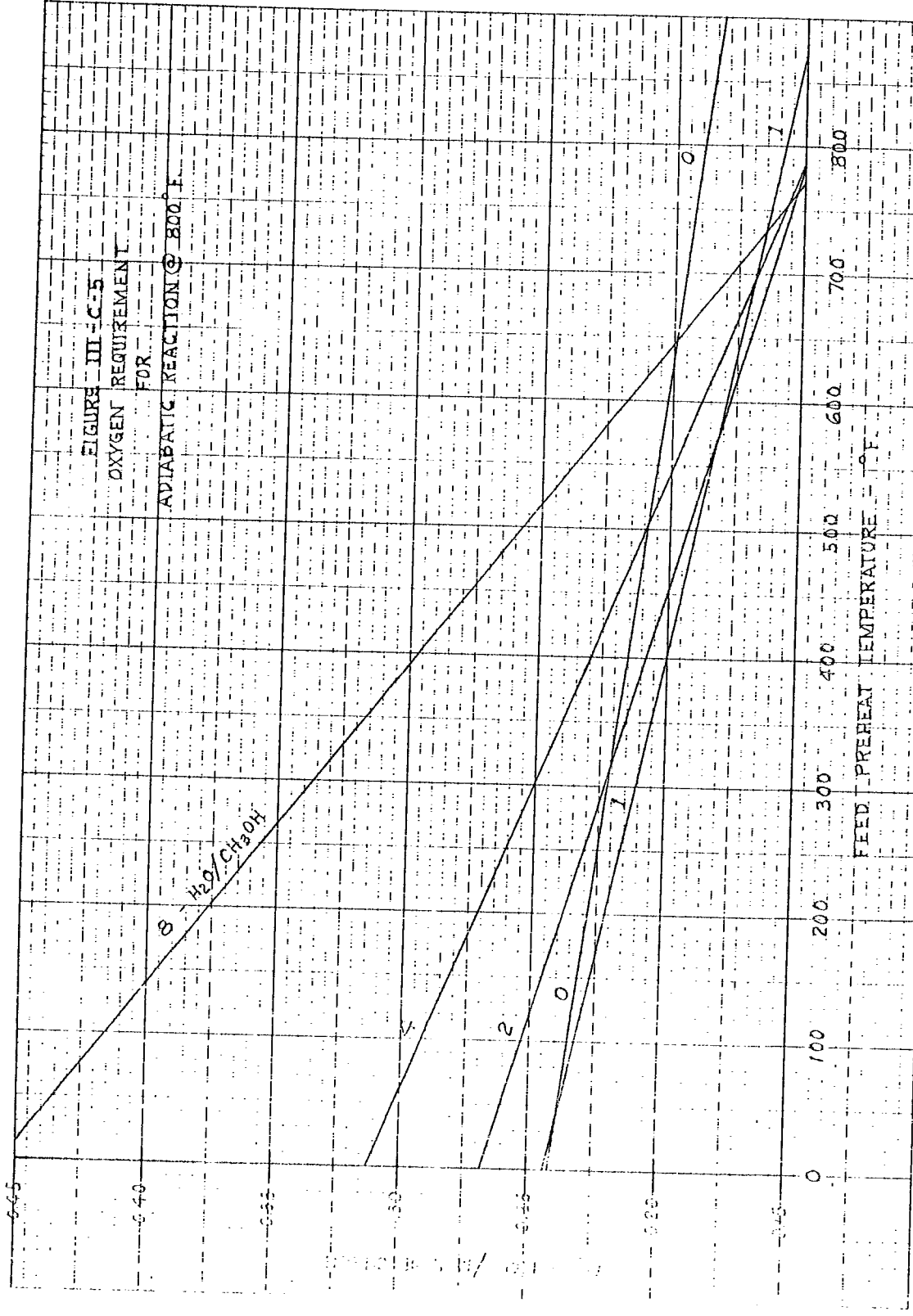

| | | |
|---|------------------------------------|----------------------------------|
| GIRDLER CORPORATION LOUISVILLE, KENTUCKY | FOR: BUREAU OF SHIPS U. S. NAVY | DRAWING NUMBER A-5414-III-C-5 |
|---|------------------------------------|----------------------------------|

K&E 10 X 10 TO THE INCH 359-5DG
KEUFFEL & ESSER CO. MADE IN U. S. A.

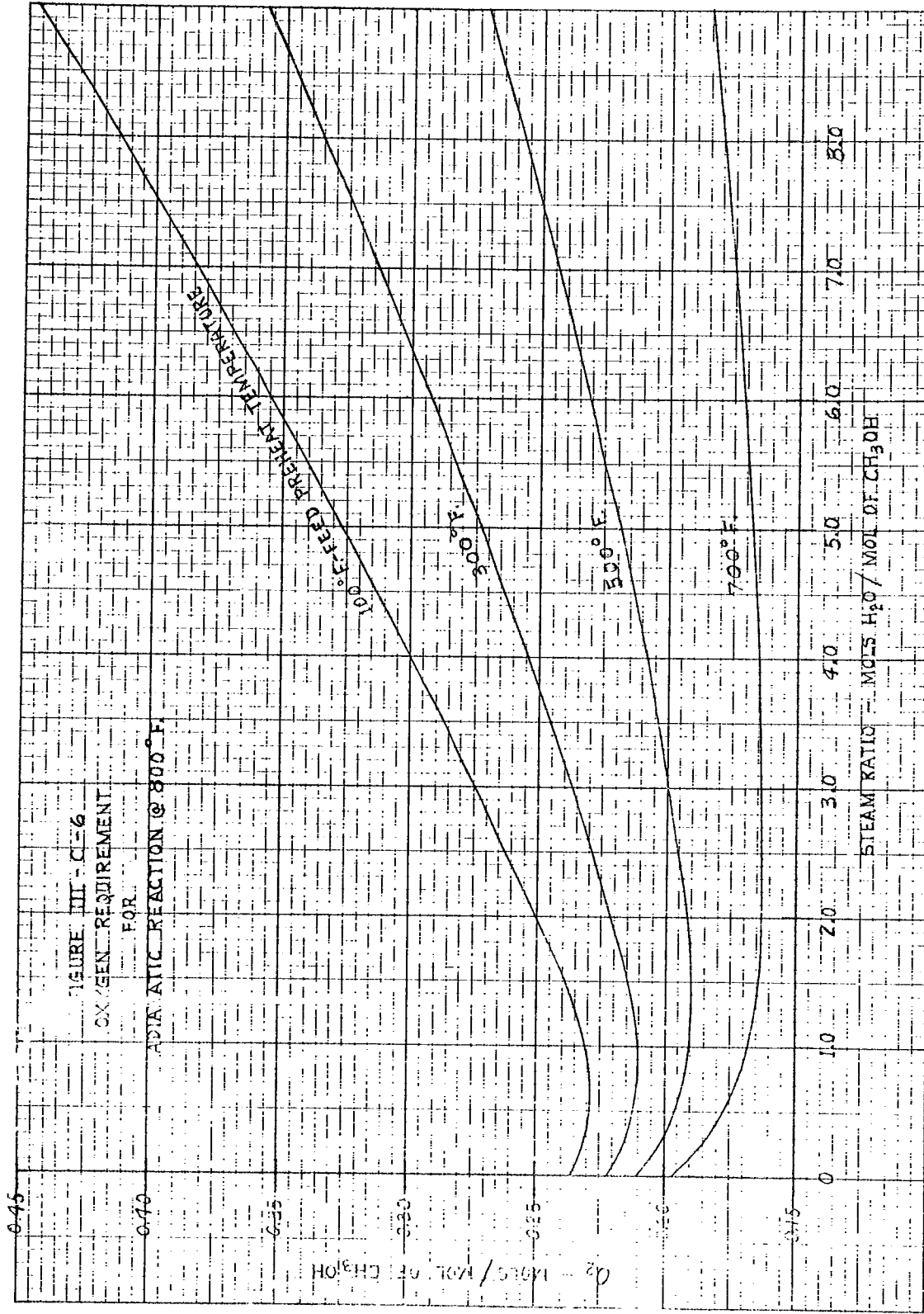

GIRDLER CORPORATION
LOUISVILLE, KENTUCKY

FOR: BUREAU OF SHIPS
U. S. NAVY

DRAWING NUMBER
A-5414-III-C-6

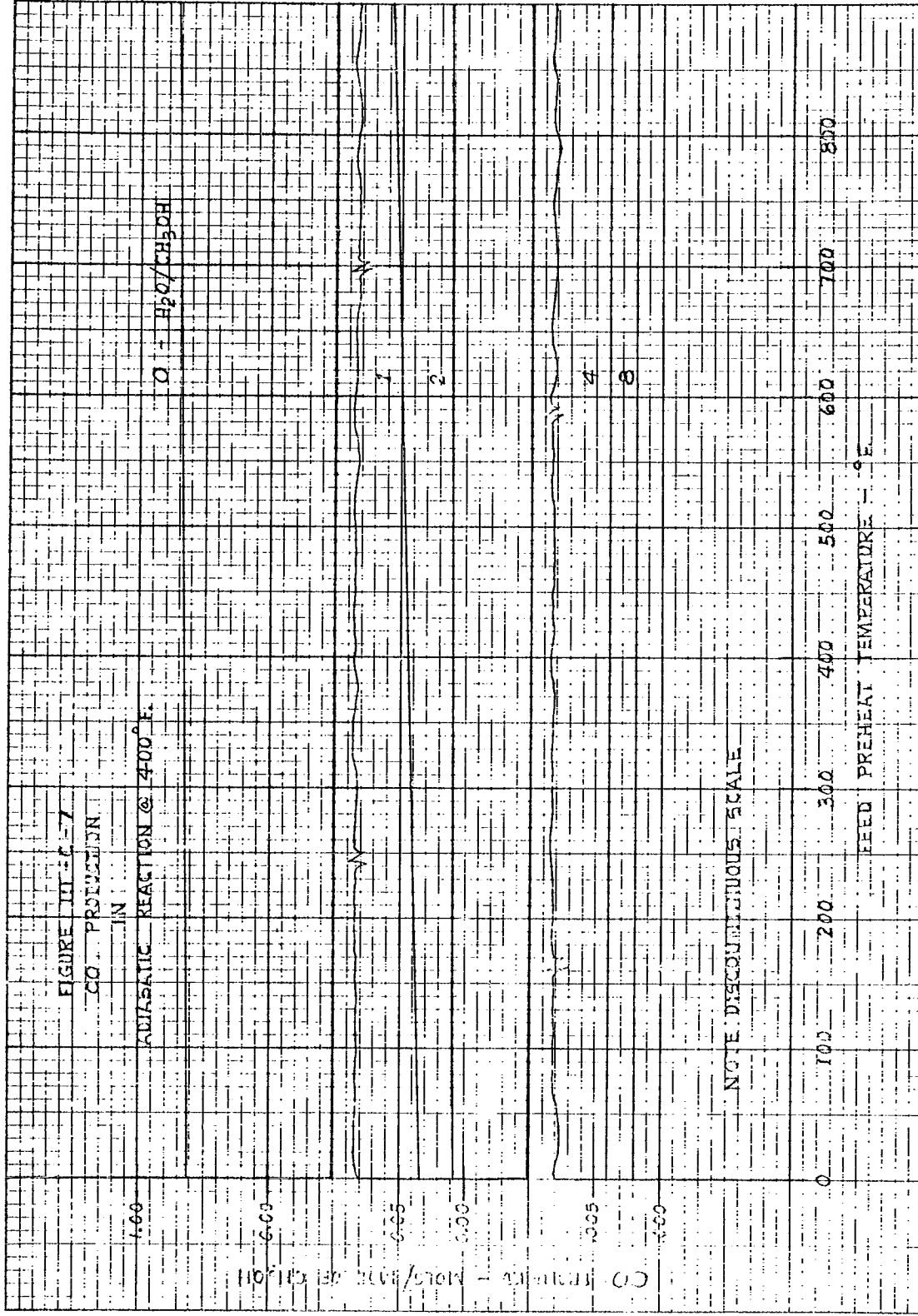

GIRDLER CORPORATION
 LOUISVILLE, KENTUCKY

FOR: BUREAU OF SHIPS
 U. S. NAVY

DRAWING NUMBER
 A-5414-III-C-7

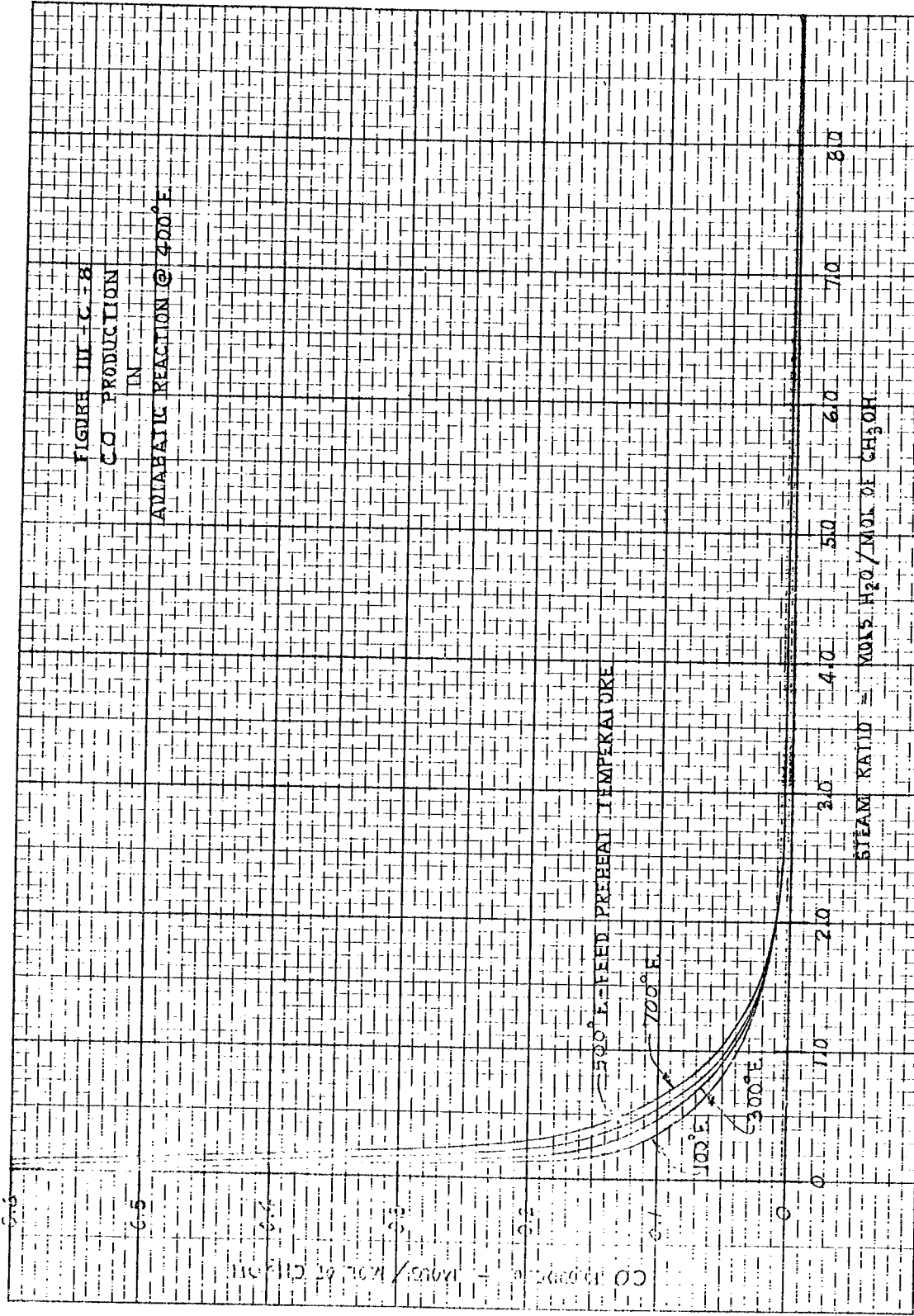

| | | |
|---|------------------------------------|----------------------------------|
| GIRDLER CORPORATION LOUISVILLE, KENTUCKY | FOR: BUREAU OF SHIPS U. S. NAVY | DRAWING NUMBER A-5414-III-C-8 |
|---|------------------------------------|----------------------------------|

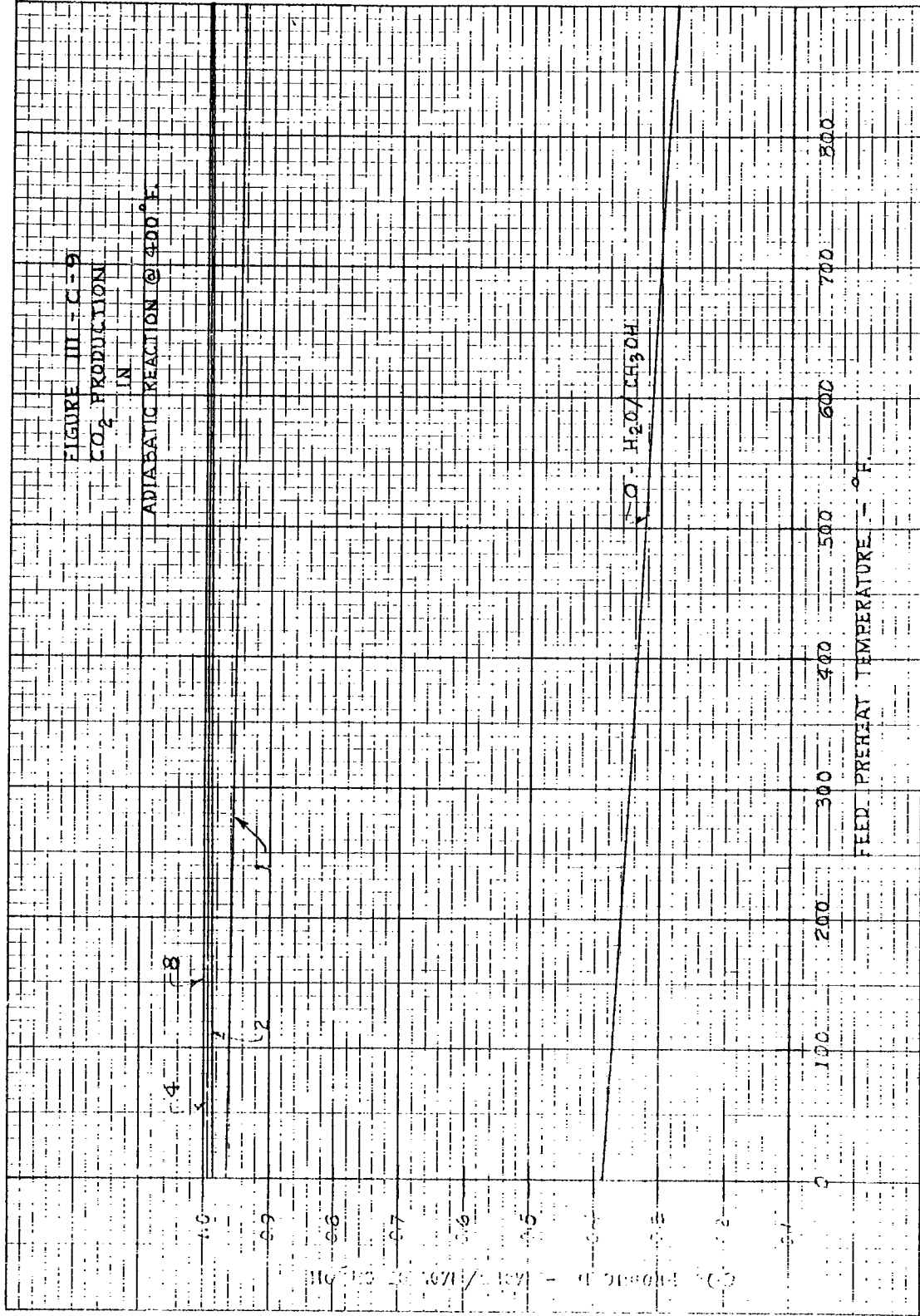

| | |
|---|------------------------------------|
| GIRDLER CORPORATION LOUISVILLE, KENTUCKY | FOR: BUREAU OF SHIPS U. S. NAVY |
| DRAWING NUMBER A-5414-III-C-9 | |

1/4" 10X10 TO 1/4" INCH 359-50G
 KUPFFEL & ESSER CO. MADE IN U.S.A.

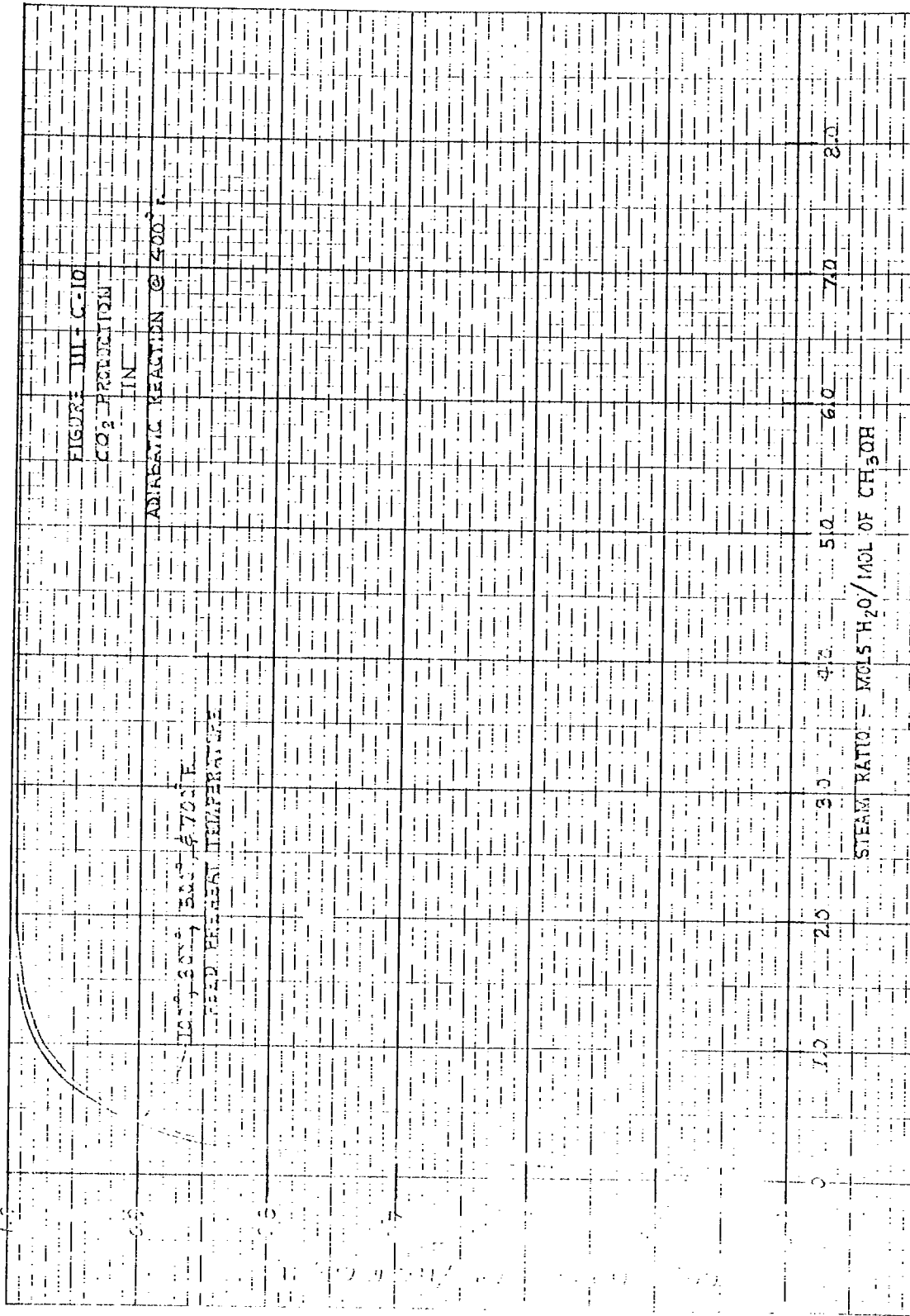

GIRDLER CORPORATION
 LOUISVILLE, KENTUCKY

FOR: BUREAU OF SHIPS
 U. S. NAVY

DRAWING NUMBER
 A-5414-III-C-10

10 X 10 TO THE INCH 359-50G
 KEUFFEL & ESSER CO. MADE IN U.S.A.

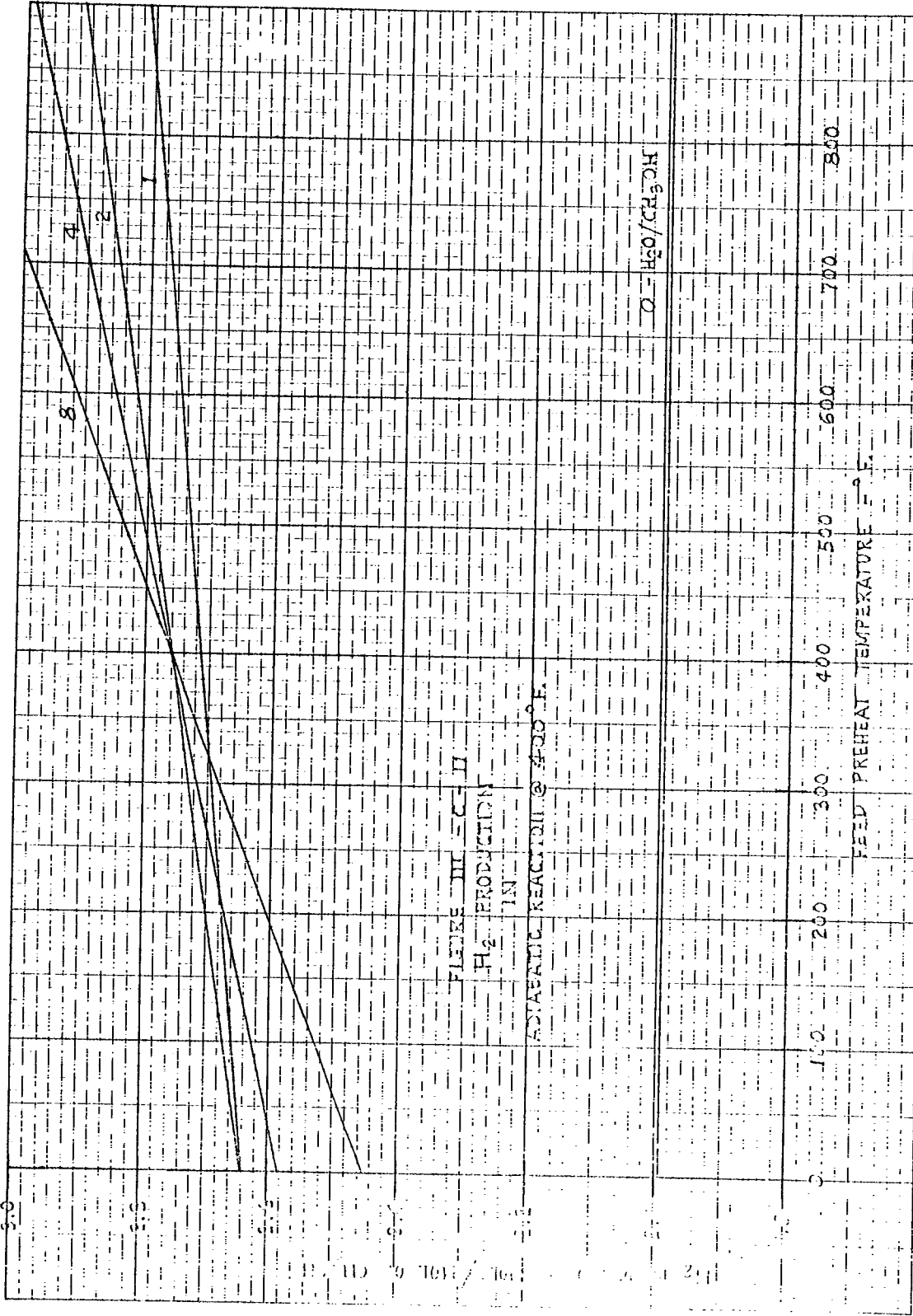

GIRDLER CORPORATION
 LOUISVILLE, KENTUCKY

FOR: BUREAU OF SHIPS
 U. S. NAVY

DRAWING NUMBER
 A-5414-III-C-11

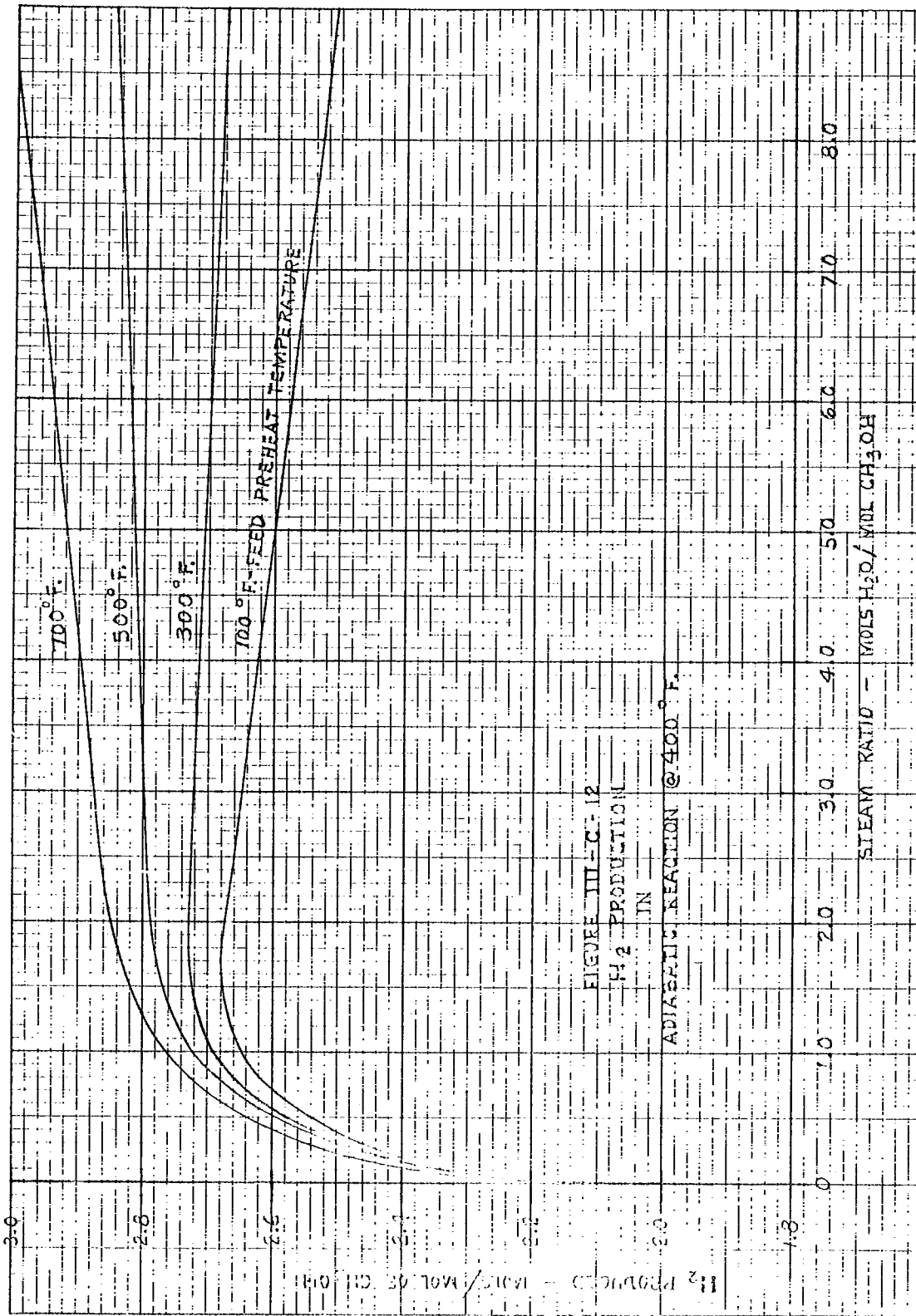

FIGURE III-C-12

H₂ PRODUCTION

IN

ADIPALIC REACTION @ 400° F.

GIRDLER CORPORATION
LOUISVILLE, KENTUCKY

FOR: BUREAU OF SHIPS
U. S. NAVY

DRAWING NUMBER
A-5414-III-C-12

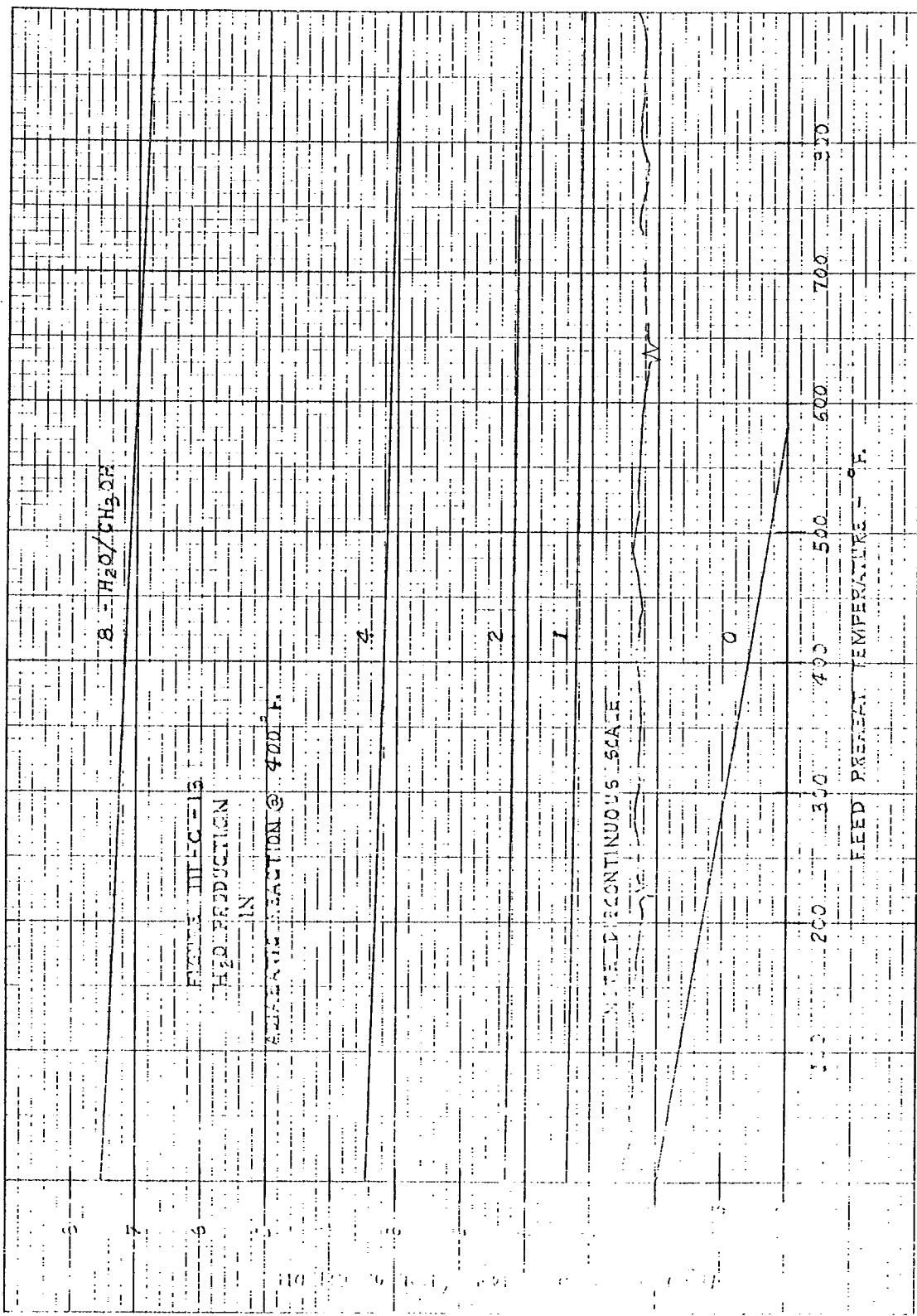

GIRDLER CORPORATION
LOUISVILLE, KENTUCKY

FOR: BUREAU OF SHIPS
U. S. NAVY

DRAWING NUMBER
A-5414-III-C-13

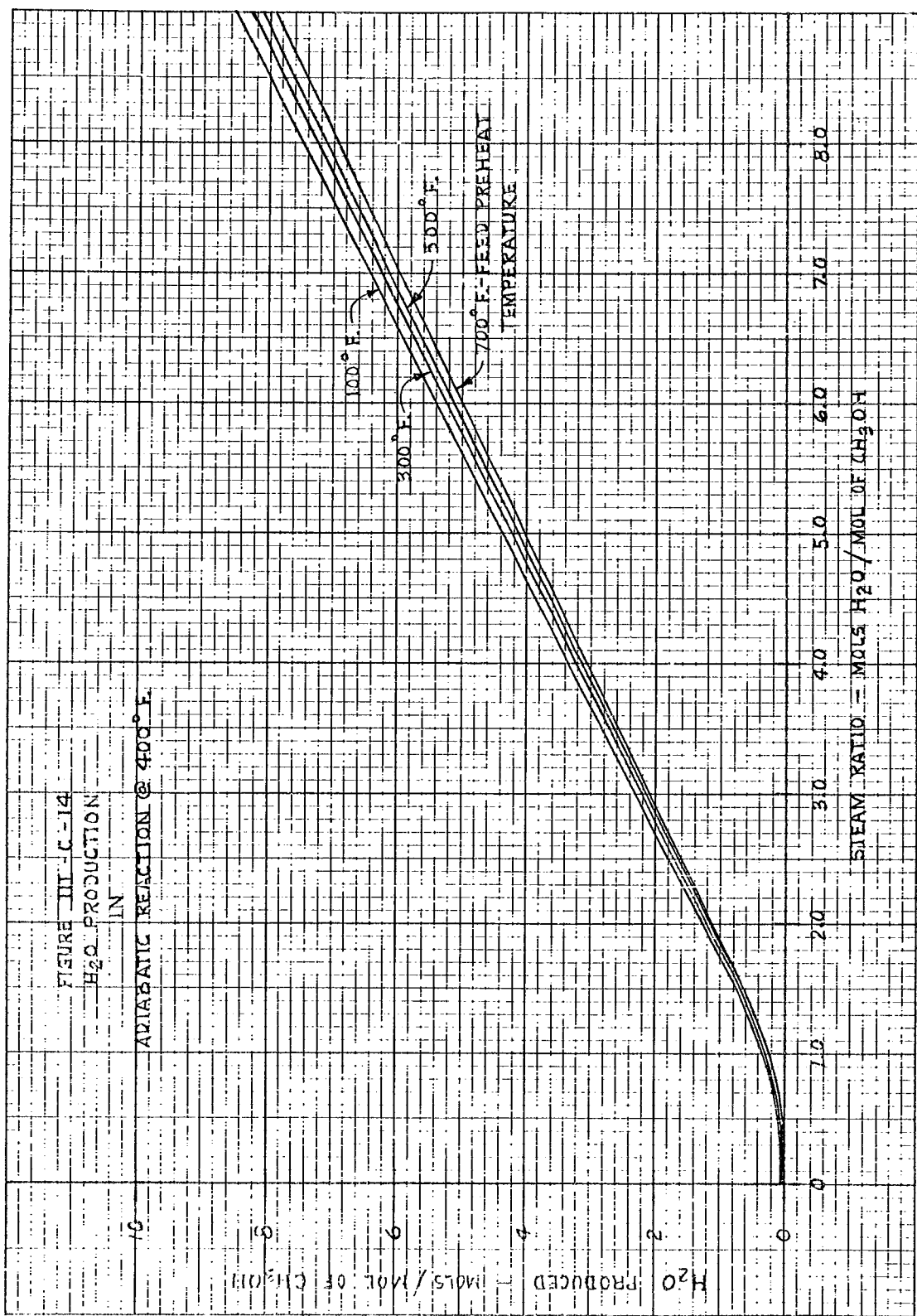

GIRDLER CORPORATION
LOUISVILLE, KENTUCKY

FOR: BUREAU OF SHIPS
U. S. NAVY

DRAWING NUMBER
A-5414-III-C-14

K&E 10 X 10 TO THE INCH 359-5DG
 KEUFFEL & ESSER CO. MADRID, S.A.

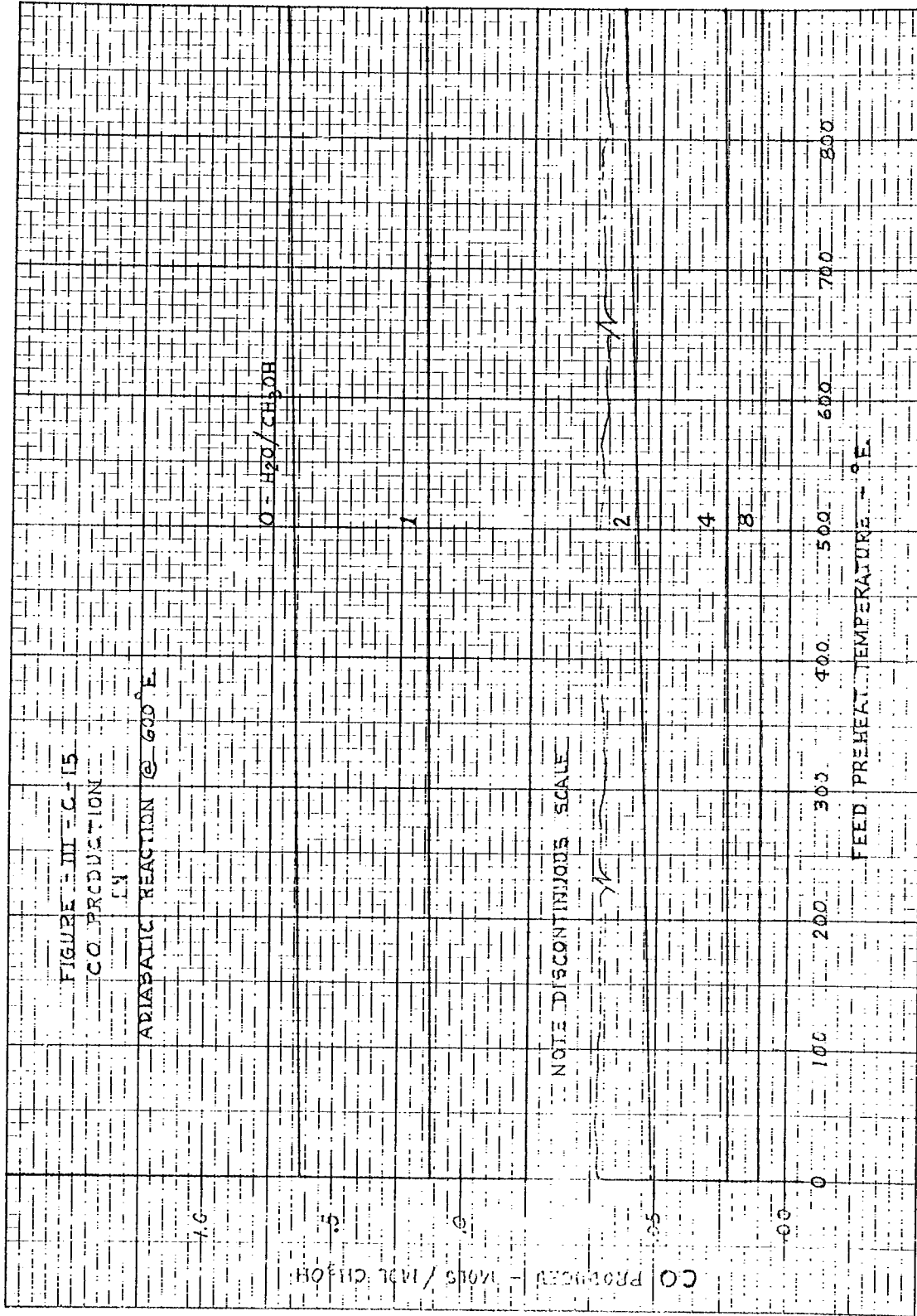

| | | | | |
|---|--|------------------------------------|--|-----------------------------------|
| GIRDLER CORPORATION LOUISVILLE, KENTUCKY | | FOR: BUREAU OF SHIPS U. S. NAVY | | DRAWING NUMBER A-5414-III-C-15 |
|---|--|------------------------------------|--|-----------------------------------|

10 X 10 TO THE INCH 359-SDG
 NEUFEL & KESER CO. MADE IN U.S.A.

FIGURE III-C-16

ICO PRODUCTION

IN

ADIABATIC REACTION @ 600° F.

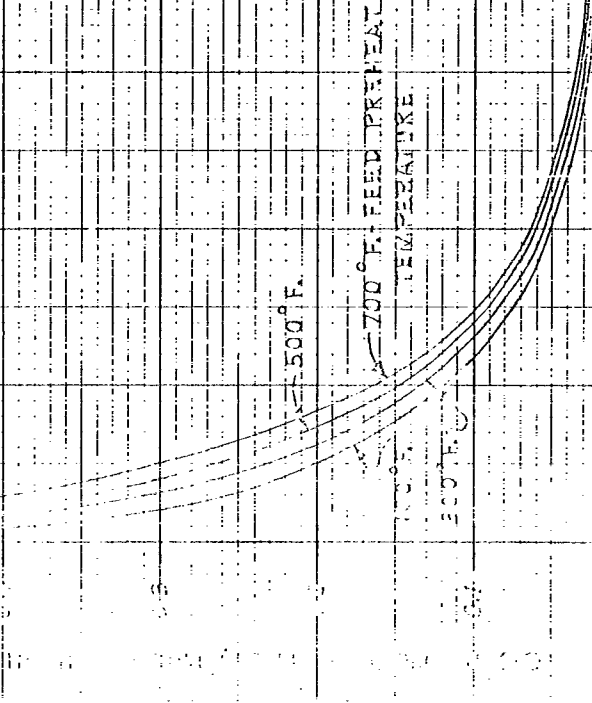

0 1.0 2.0 3.0 4.0 5.0 6.0 7.0 8.0

STEAM RATIO - MOLES H₂O/MOL OF CH₃OH

GIRDLER CORPORATION
 LOUISVILLE, KENTUCKY

FOR: BUREAU OF SHIPS
 U. S. NAVY

DRAWING NUMBER
 A-5414-III-C-16

SCALE 10 X 10 TO THE INCH 359-5DG
 W. A. RAYBURN & COMPANY, INC. MEMPHIS, TENN.

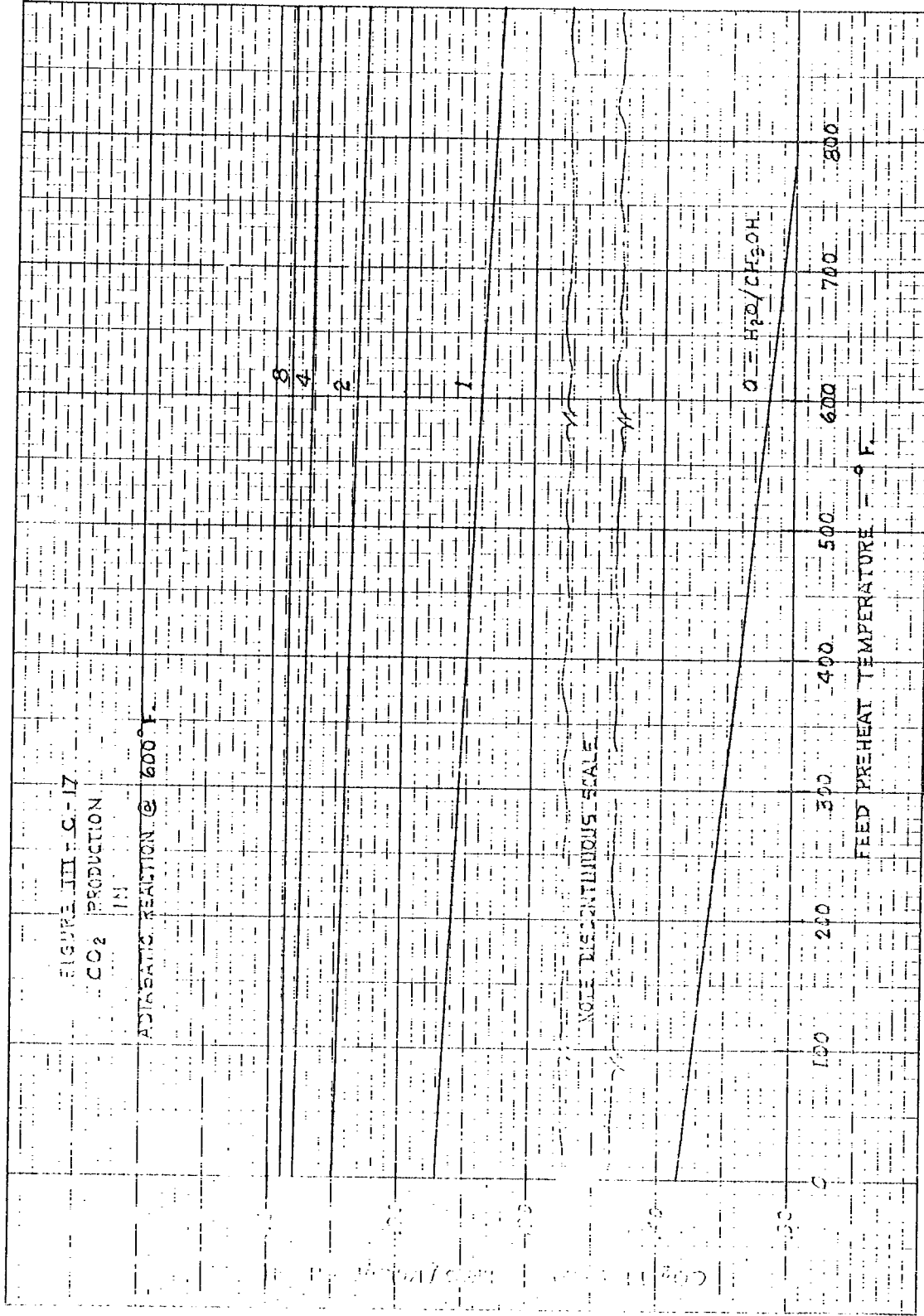

GIRDLER CORPORATION
 LOUISVILLE, KENTUCKY

FOR: BUREAU OF SHIPS
 U. S. NAVY

DRAWING NUMBER
 A-5414-III-C-17

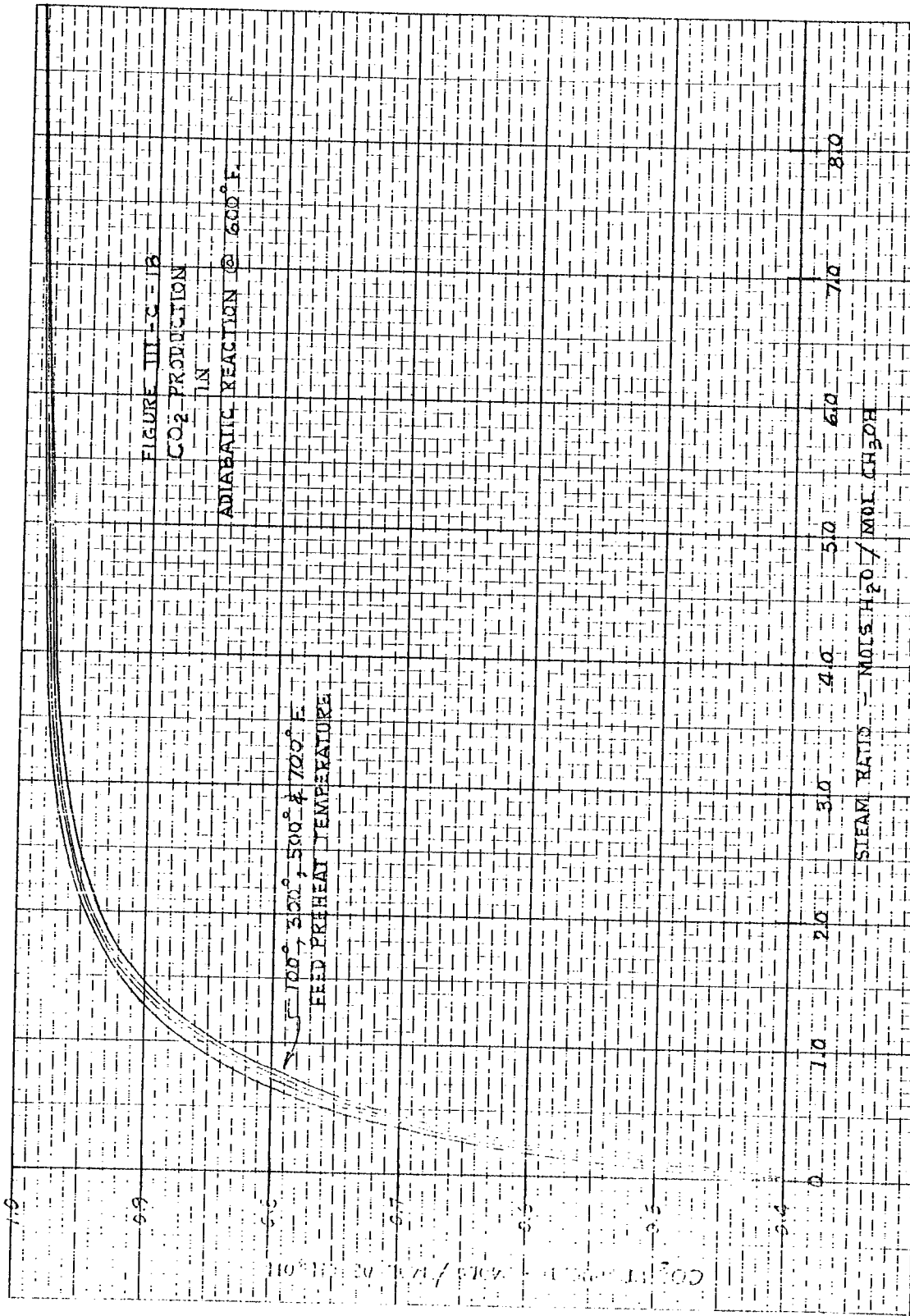

FIGURE III-C-16
 CO₂ PRODUCTION
 LN

GIRDLER CORPORATION
 LOUISVILLE, KENTUCKY

FOR: BUREAU OF SHIPS
 U. S. NAVY

DRAWING NUMBER
 A-5414-III-C-16

K&E 10 X 10 TO THE INCH 359-SDG
KEUFFEL & ESSER CO. MADE IN U.S.A.

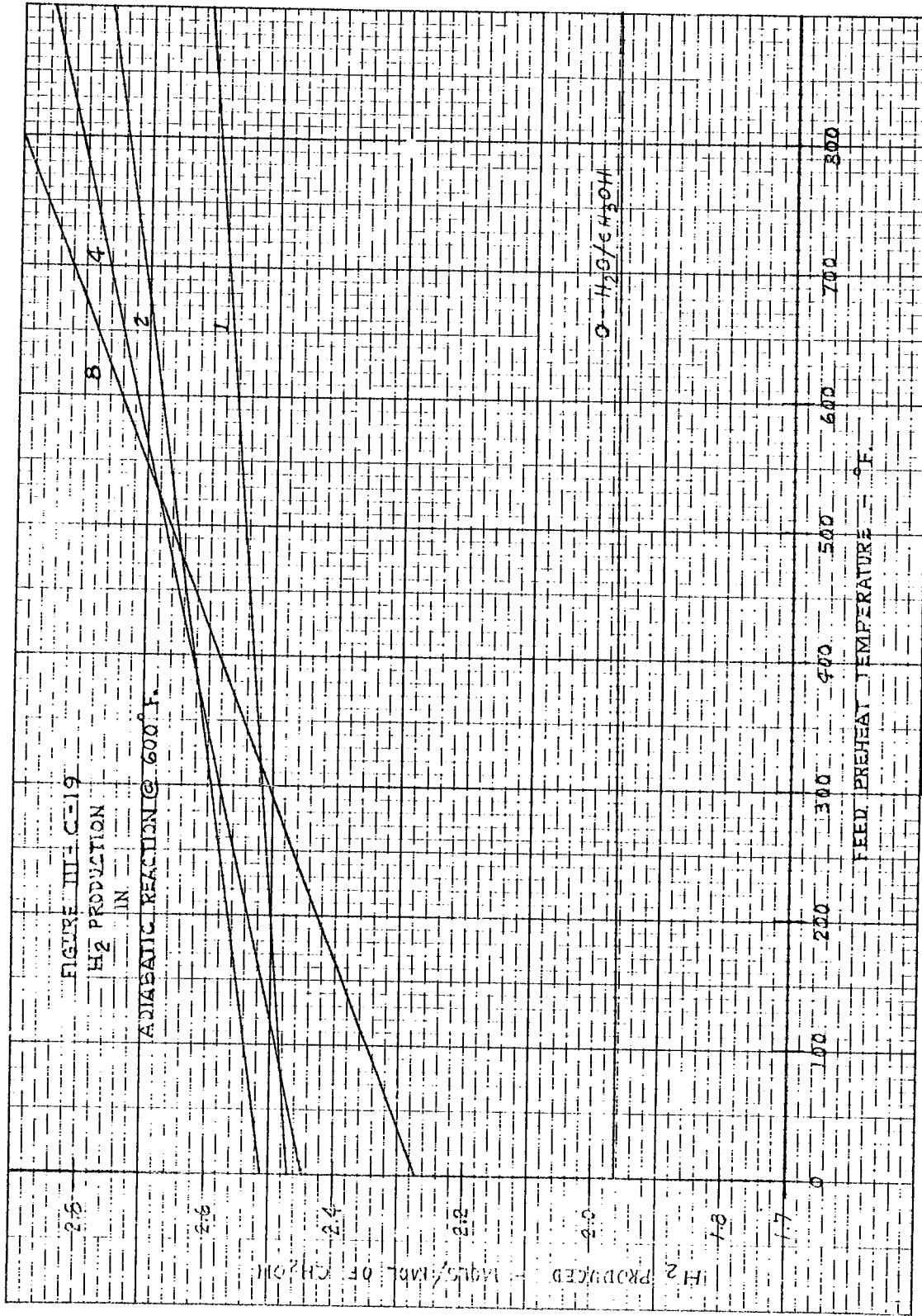

| | | |
|---|------------------------------------|-----------------------------------|
| GIRDLER CORPORATION LOUISVILLE, KENTUCKY | FOR: BUREAU OF SHIPS U. S. NAVY | DRAWING NUMBER A-5414-III-C-19 |
|---|------------------------------------|-----------------------------------|

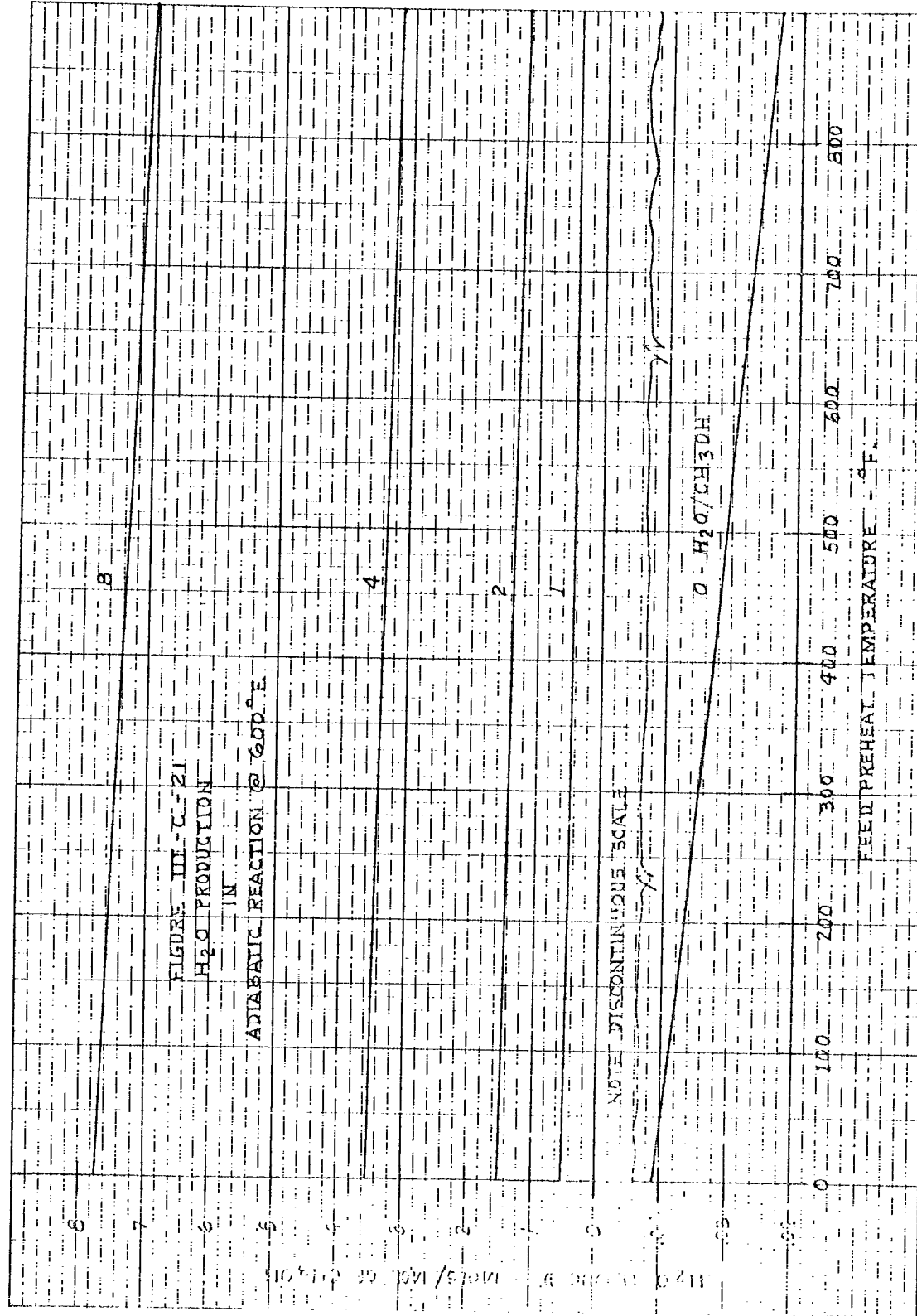

| | | |
|---|------------------------------------|-----------------------------------|
| GIRDLER CORPORATION LOUISVILLE, KENTUCKY | FOR: BUREAU OF SHIPS U. S. NAVY | DRAWING NUMBER A-5414-III-C-21 |
|---|------------------------------------|-----------------------------------|

12 X 10 TO THE INCH 359-5DG
 THE KODAK COMPANY, ROCHESTER, N. Y., U.S.A.

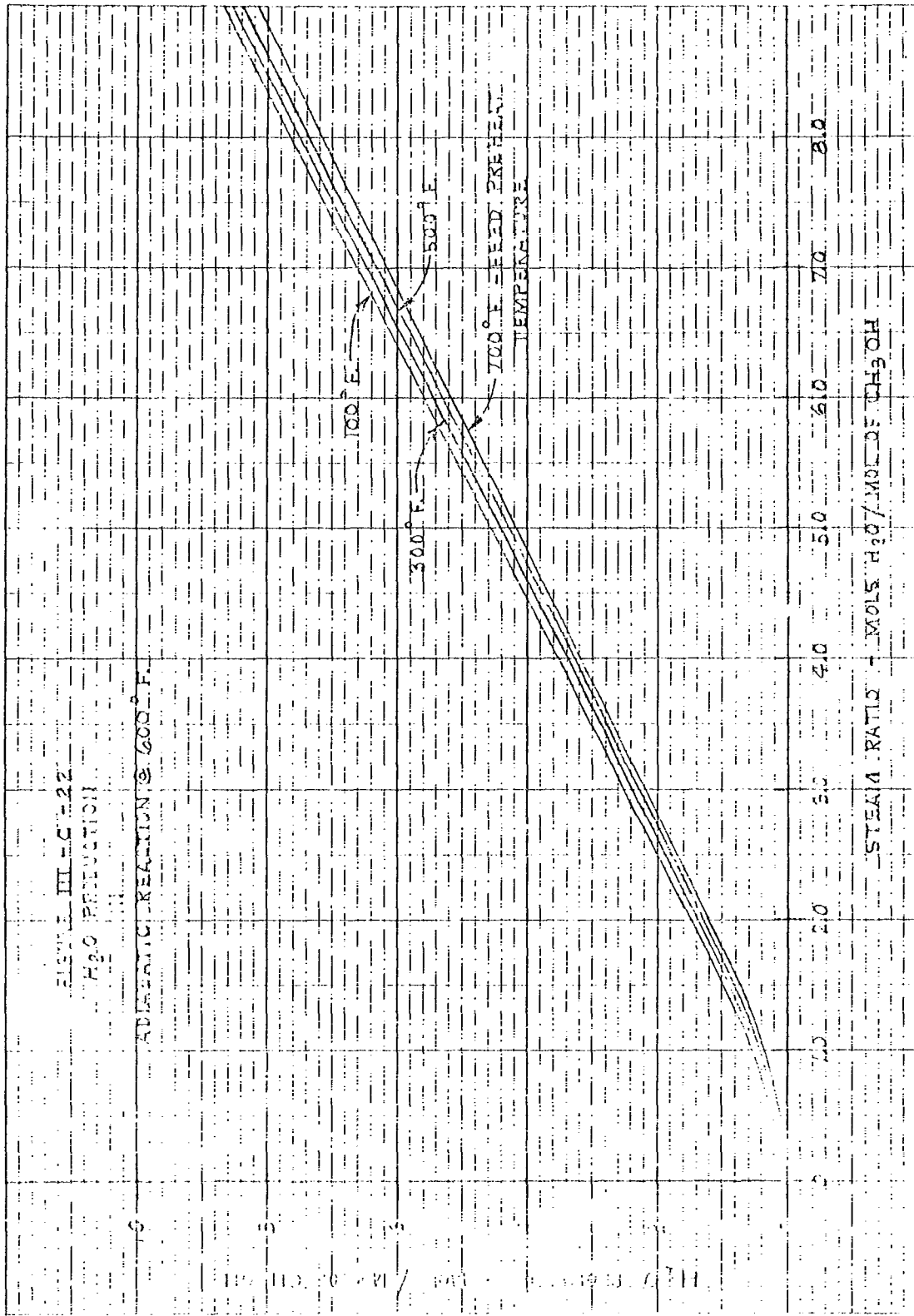

GIRDLER CORPORATION
 LOUISVILLE, KENTUCKY

FOR: BUREAU OF SHIPS
 U. S. NAVY

DRAWING NUMBER
 A-5414-III-C-22

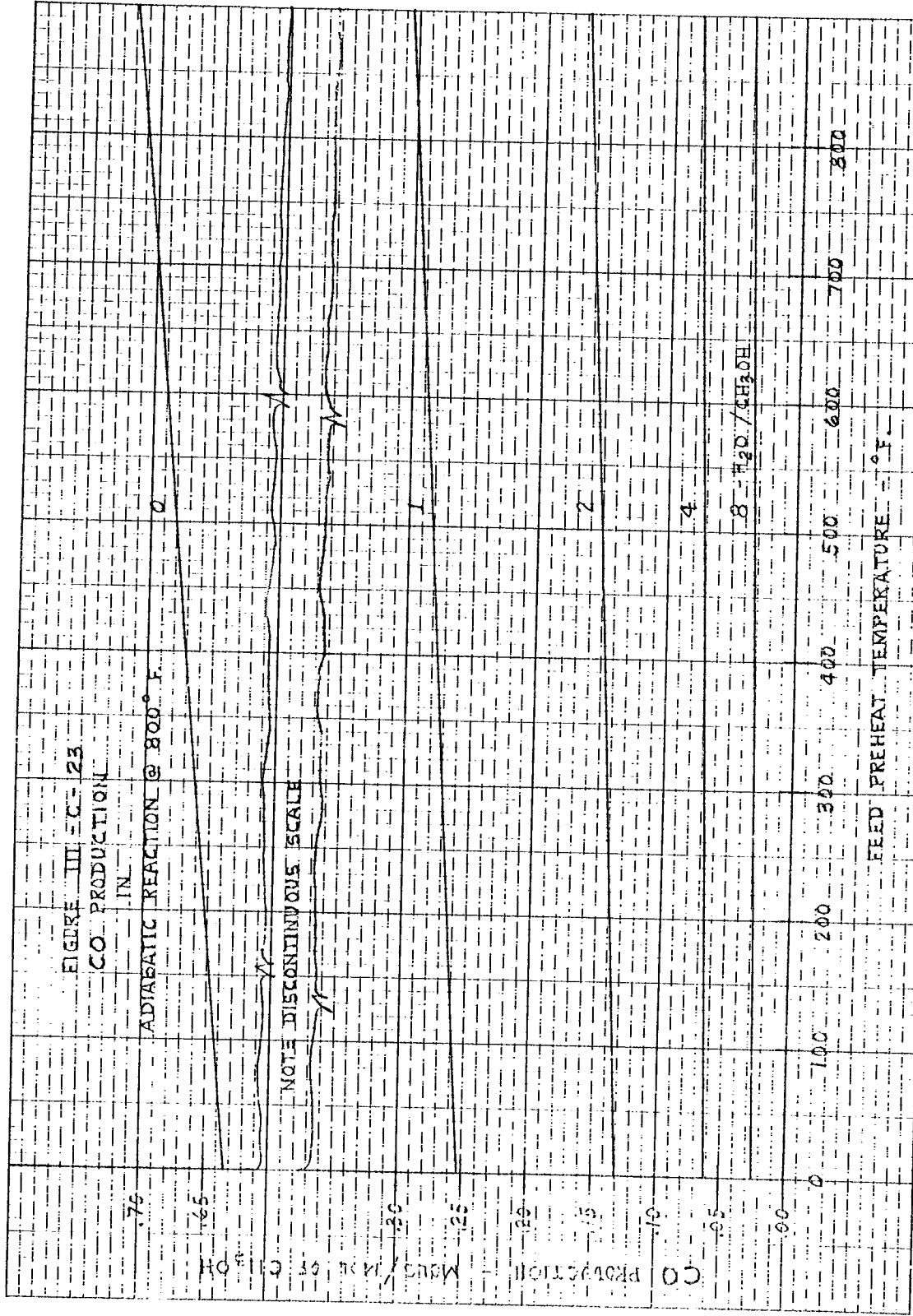

| | | |
|---|------------------------------------|-----------------------------------|
| GIRDLER CORPORATION LOUISVILLE, KENTUCKY | FOR: BUREAU OF SHIPS U. S. NAVY | DRAWING NUMBER A-5414-III-C-23 |
|---|------------------------------------|-----------------------------------|

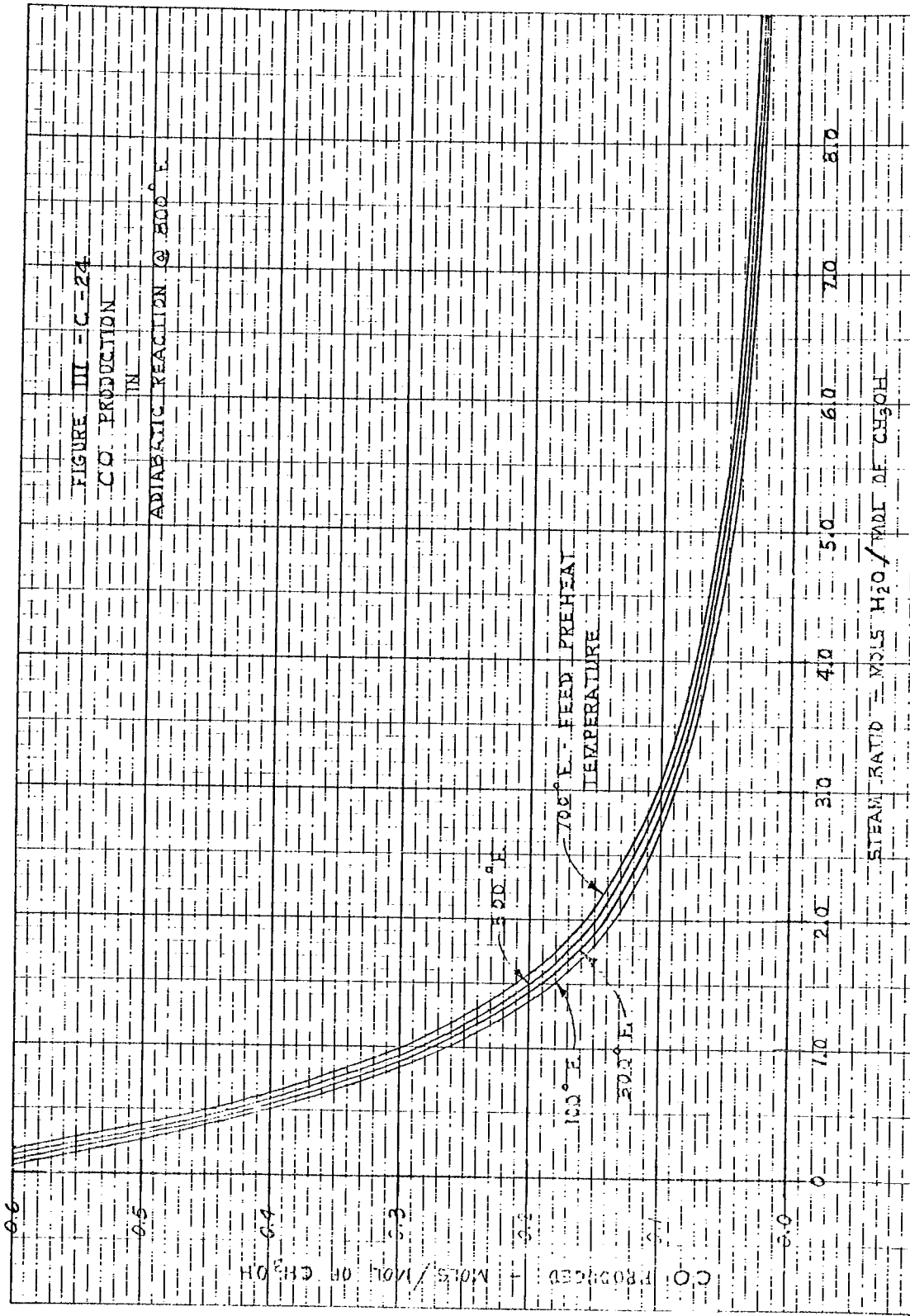

GIRDLER CORPORATION
 LOUISVILLE, KENTUCKY

FOR: BUREAU OF SHIPS
 U. S. NAVY

DRAWING NUMBER
 A-5414-III-C-24

1000 15 X 17 1/2 ENGINEERING PAPER
 MANUFACTURED BY THE NEW YORK GRAPHIC COMPANY

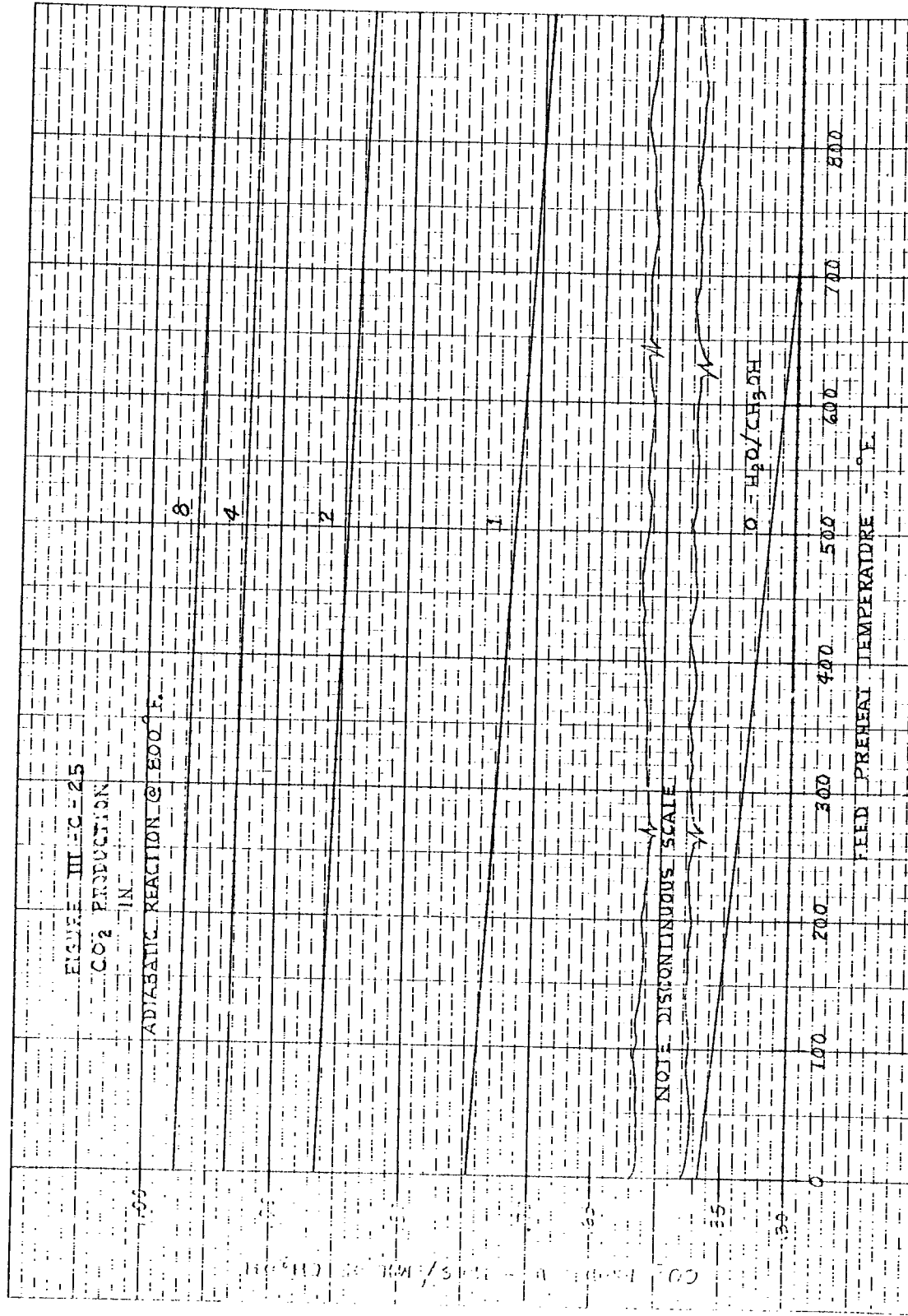

GIRDLER CORPORATION
 LOUISVILLE, KENTUCKY

FOR: BUREAU OF SHIPS
 U. S. NAVY

DRAWING NUMBER
 A-5414-III-C-25

KE 10 X 10 TO THE INCH 359-SDG
 KEUFFEL & ESSER CO. MADE IN U.S.A.

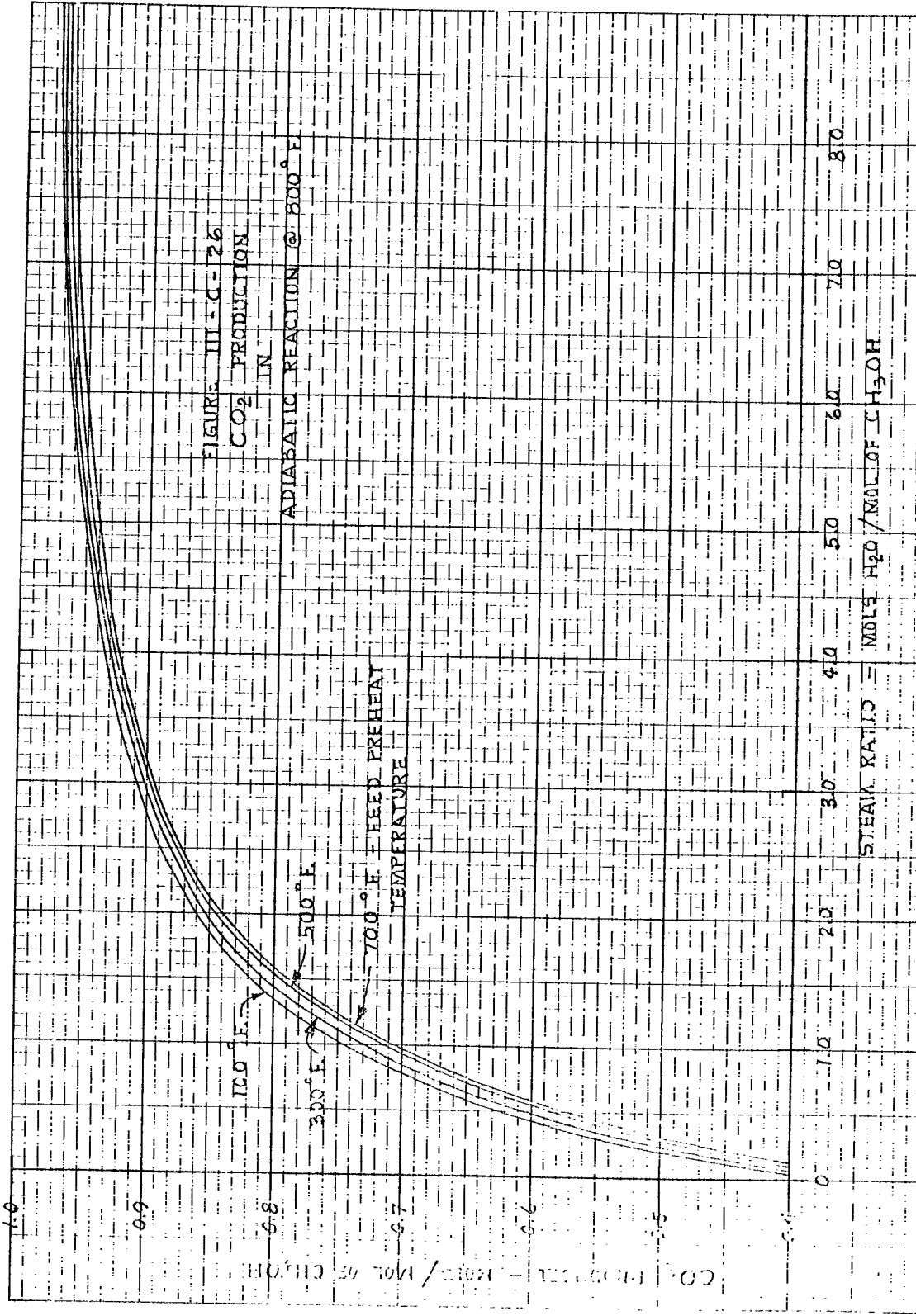

GIRDLER CORPORATION
 LOUISVILLE, KENTUCKY

FOR: BUREAU OF SHIPS
 U. S. NAVY

DRAWING NUMBER
 A-5414-III-C-26

K&S 10 X 10 TO THE INCH 359-50G
 KRUPFEL & ESSER CO. MADE IN U.S.A.

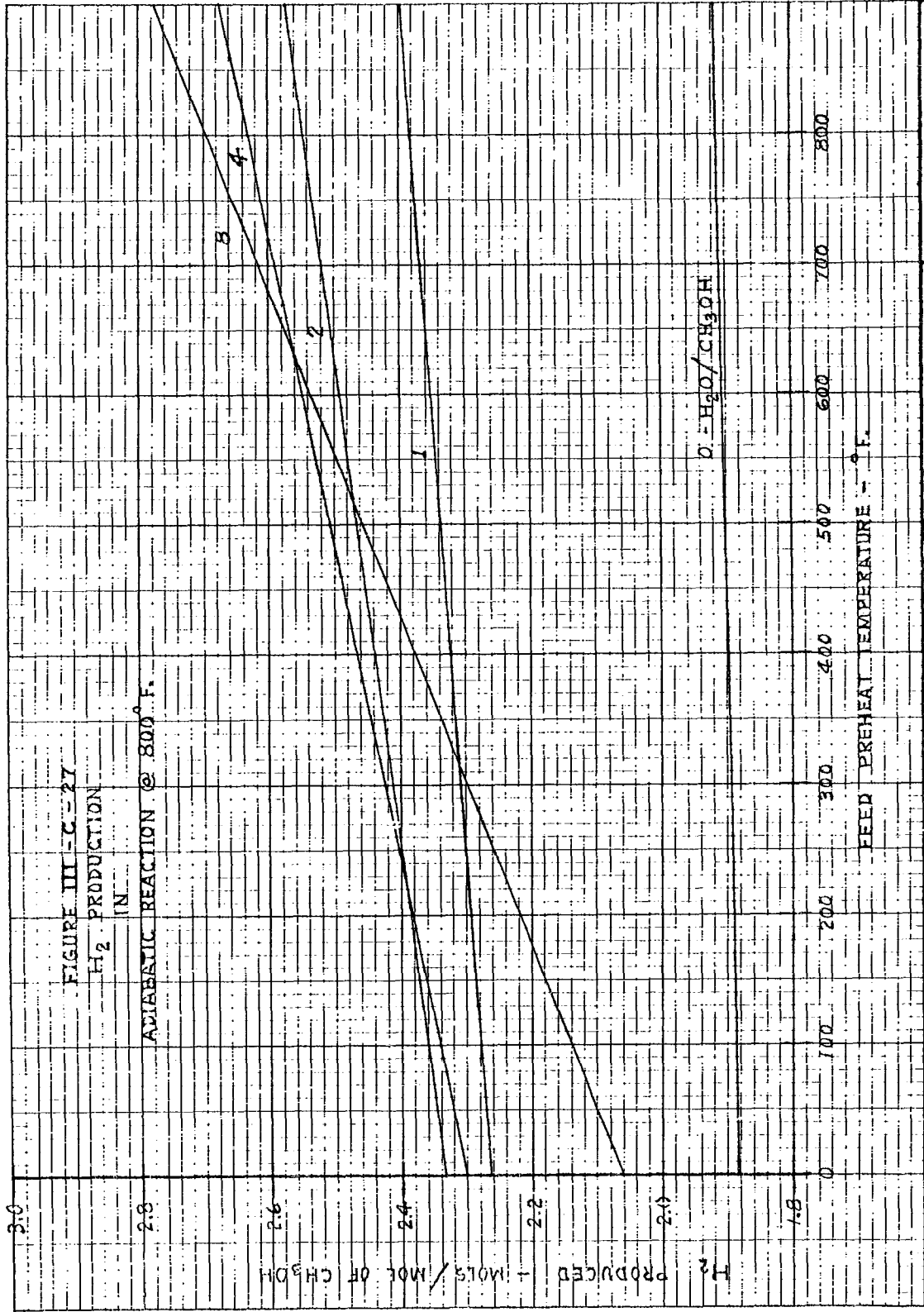

GIRDLER CORPORATION
 LOUISVILLE, KENTUCKY

FOR: BUREAU OF SHIPS
 U. S. NAVY

DRAWING NUMBER
 A-5414-III-C-27

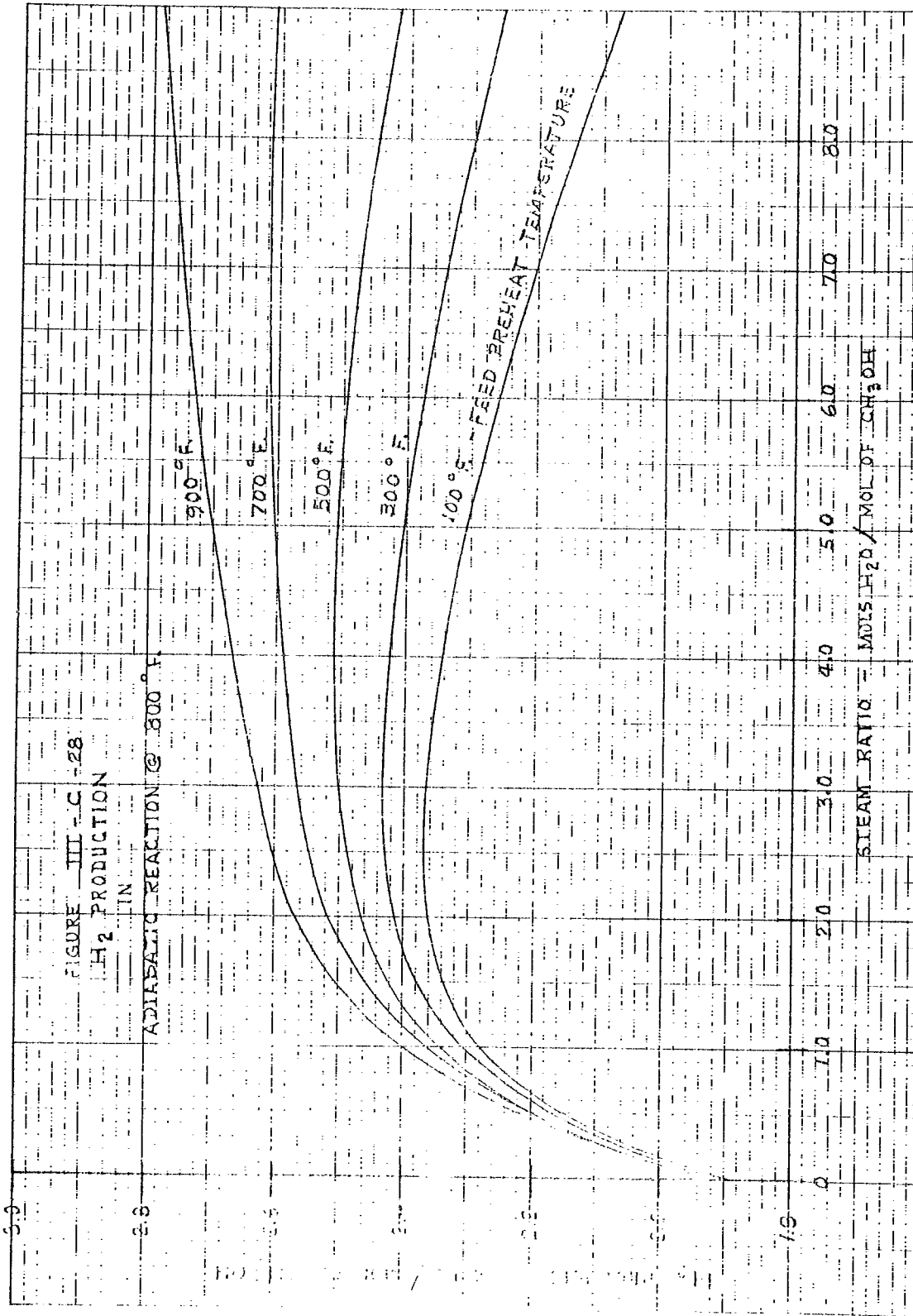

GIRDLER CORPORATION
LOUISVILLE, KENTUCKY

FOR: BUREAU OF SHIPS
U. S. NAVY

DRAWING NUMBER
A-5414-III-C-28

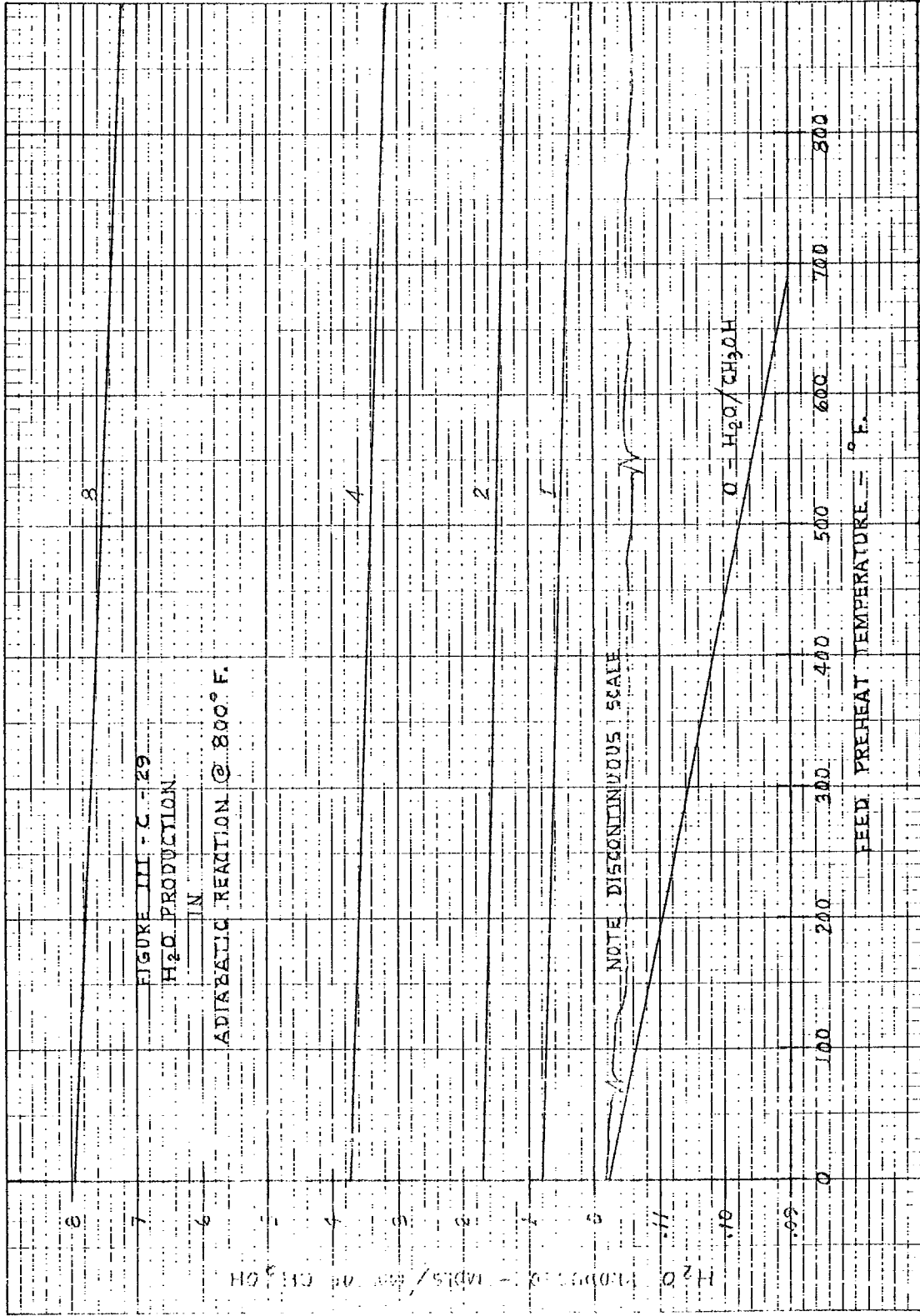

FIGURE III - C - 29
 H₂O PRODUCTION
 IN
 ADIABATIC REACTION @ 800° F.

10 X 10 TO THE INCH 355 DDG
 KEUFFEL & ESSER CO. MAKING U.S.A.

FIGURE III - C - 139

H₂O PRODUCTION

IN

ADIABATIC REACTION @ 800° F.

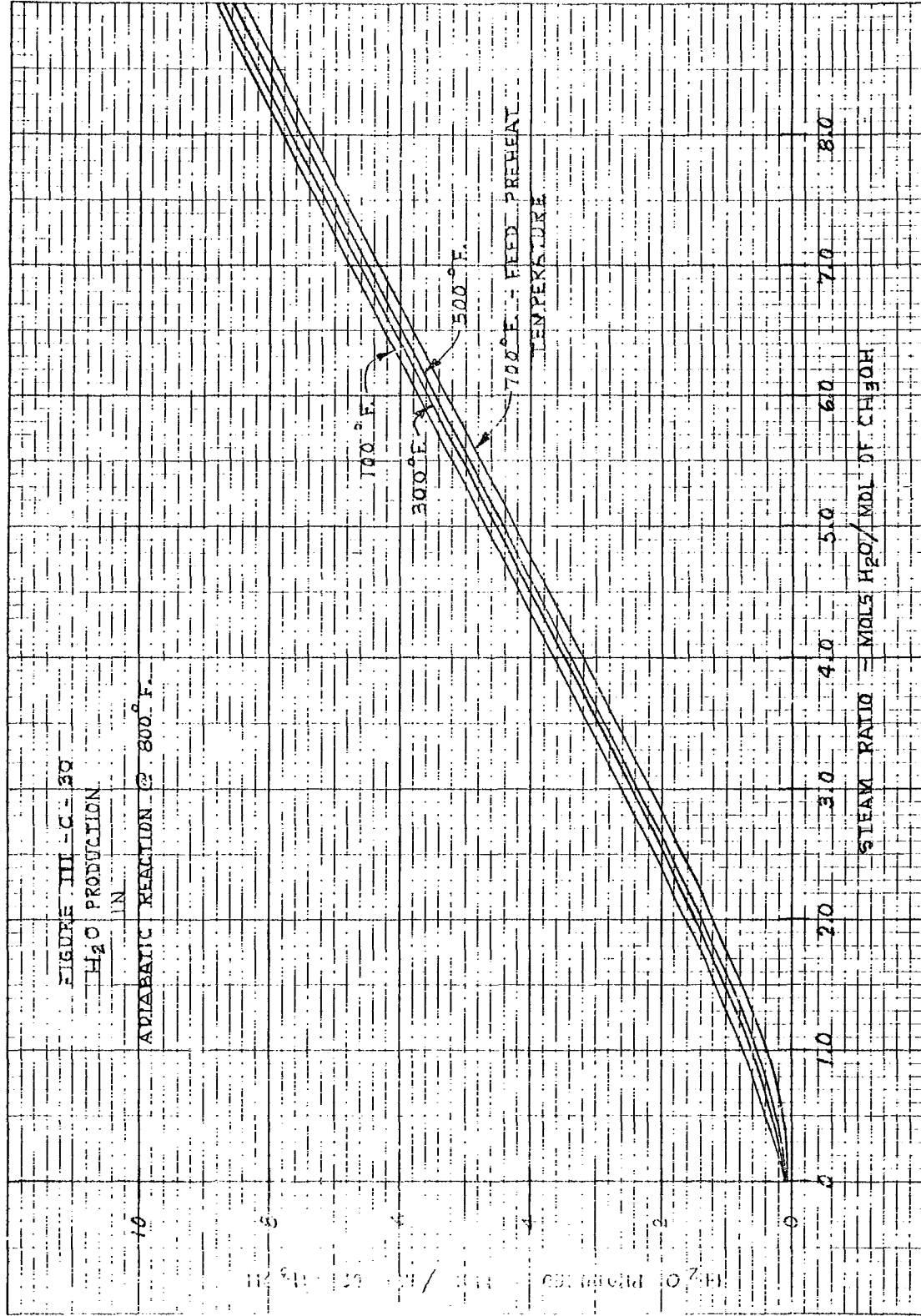

GIRDLER CORPORATION
 LOUISVILLE, KENTUCKY

FOR: BUREAU OF SHIPS
 U. S. NAVY

DRAWING NUMBER
 A-5414-III-C-30

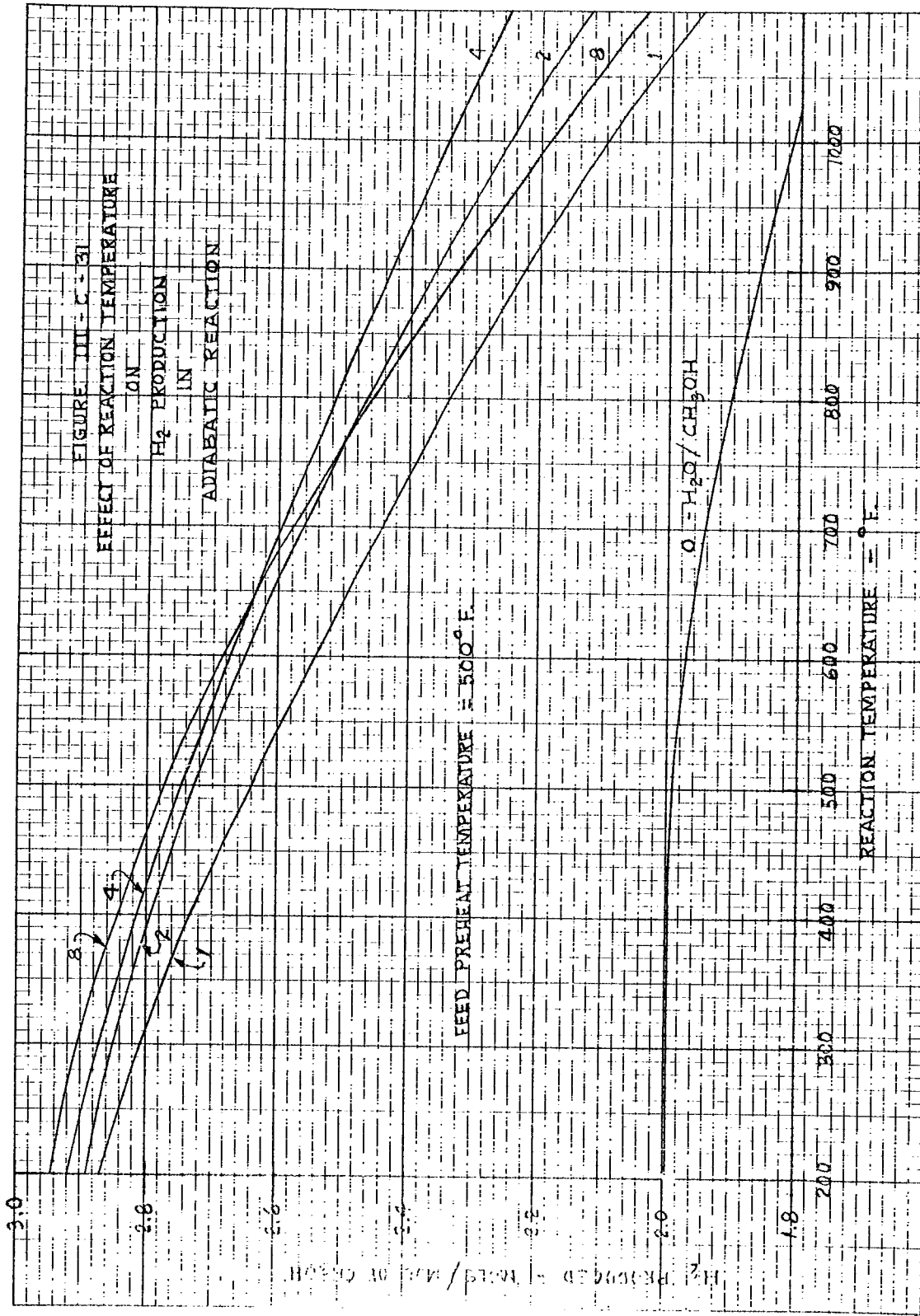

GIRDLER CORPORATION
LOUISVILLE, KENTUCKY

FOR: BUREAU OF SHIPS
U. S. NAVY

DRAWING NUMBER
A-5414-III-C-31

10 X 10 TO THE INCH 359-SDG
 KEU-FEL & ESNER CO. MICHIGAN

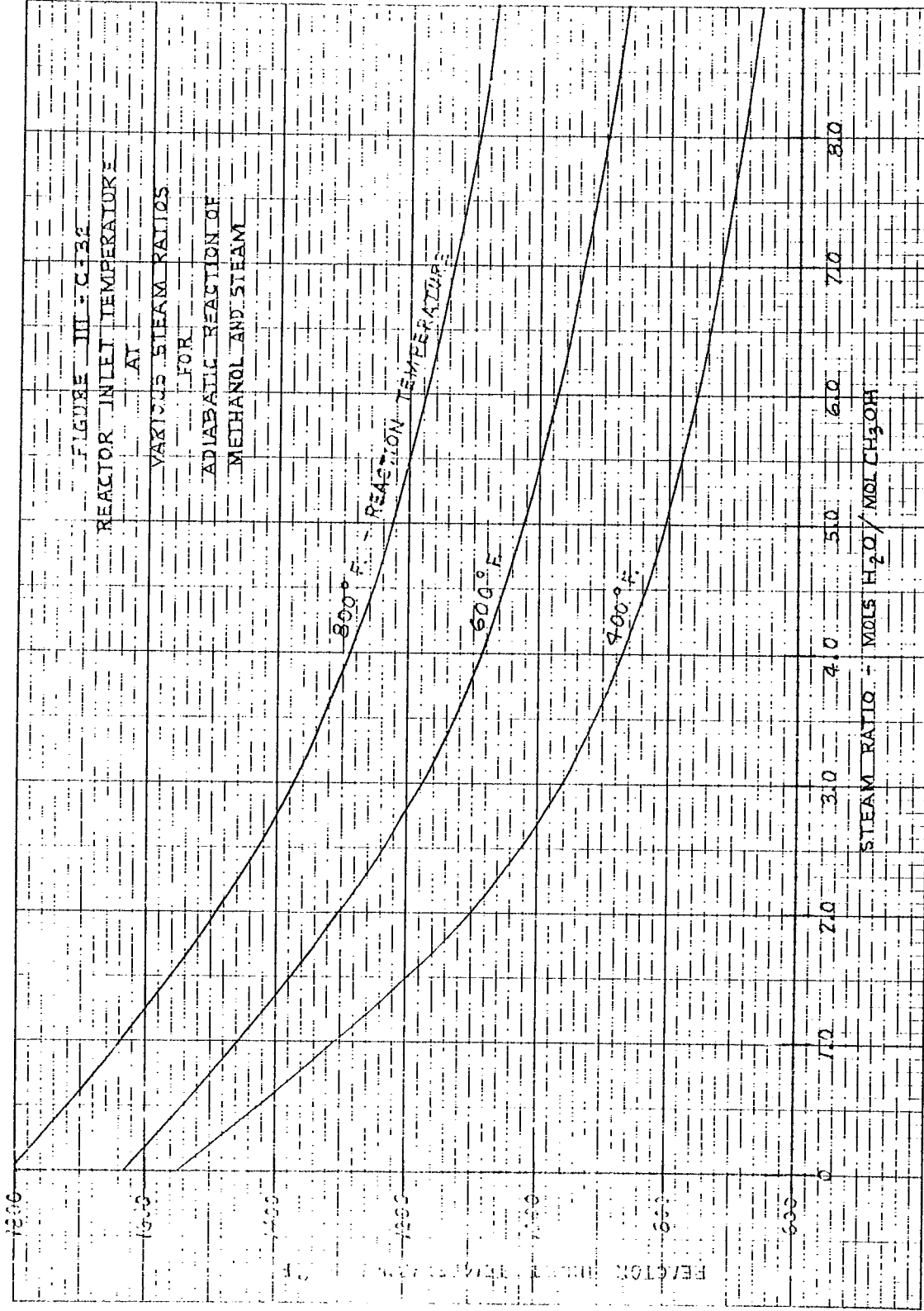
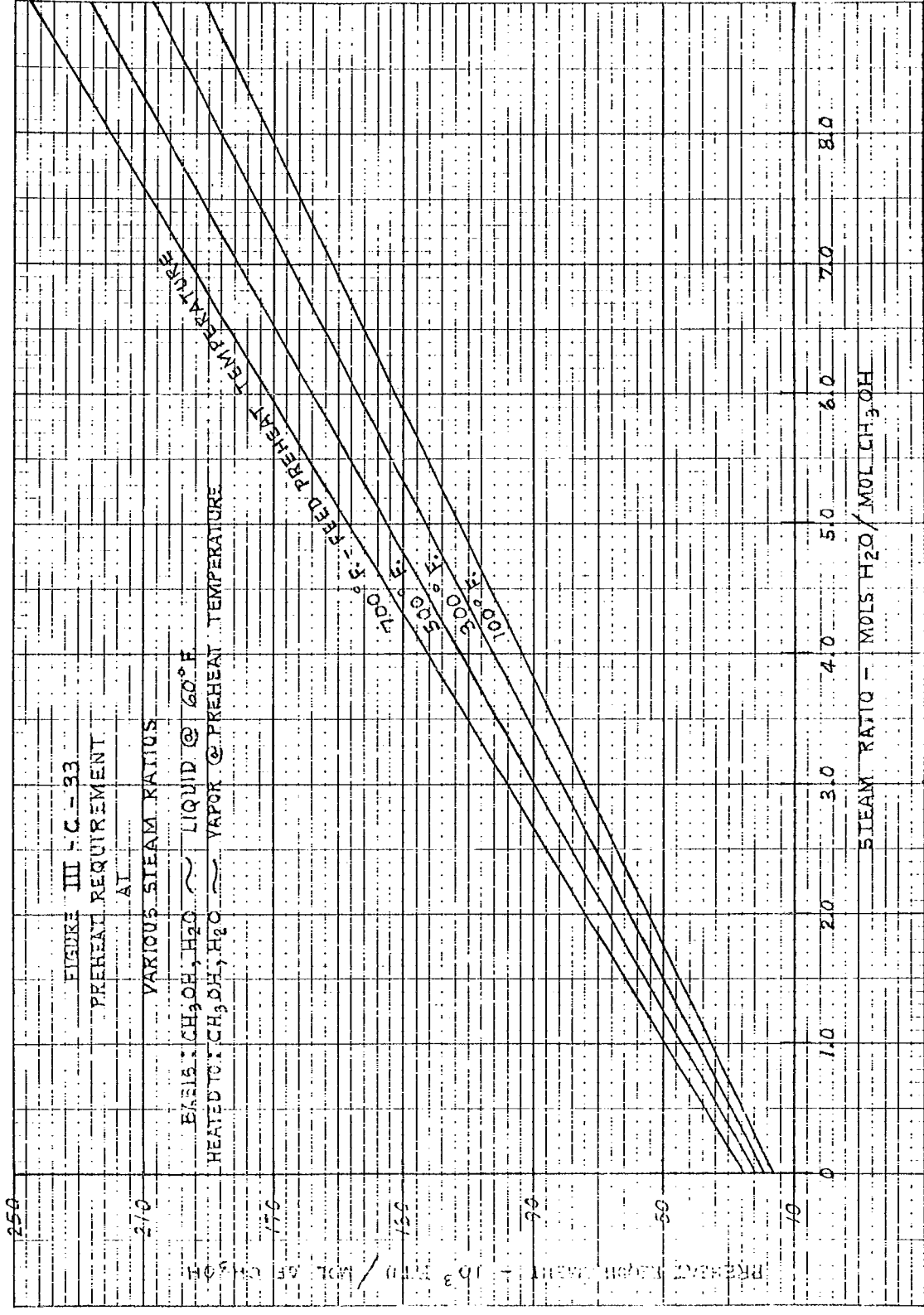

FIGURE III - C-32
 REACTOR INLET TEMPERATURE
 AT
 VARIOUS STEAM RATIOS
 FOR
 ADIABATIC REACTION OF
 METHANOL AND STEAM

GIRDLER CORPORATION
 LOUISVILLE, KENTUCKY

FOR: BUREAU OF SHIPS
 U. S. NAVY

DRAWING NUMBER
 A-5414-III-C-32



GIRDLER CORPORATION FOR: BUREAU OF SHIPS
LOUISVILLE, KENTUCKY U. S. NAVY

DRAWING NUMBER
A-5414-III-C-33

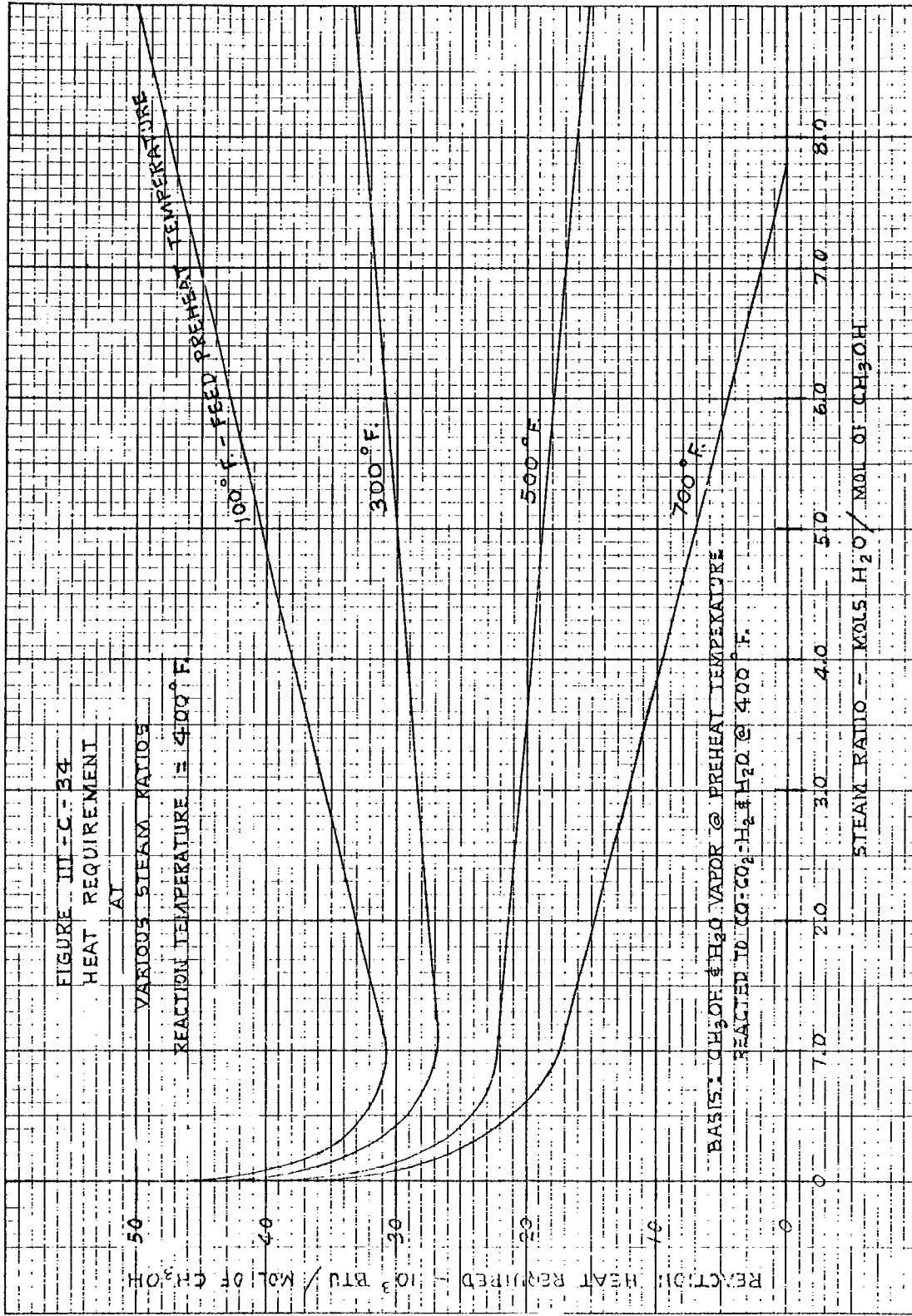

GIRDLER CORPORATION
 LOUISVILLE, KENTUCKY

FOR: BUREAU OF SHIPS
 U. S. NAVY

DRAWING NUMBER
 A-5414-III-C-34

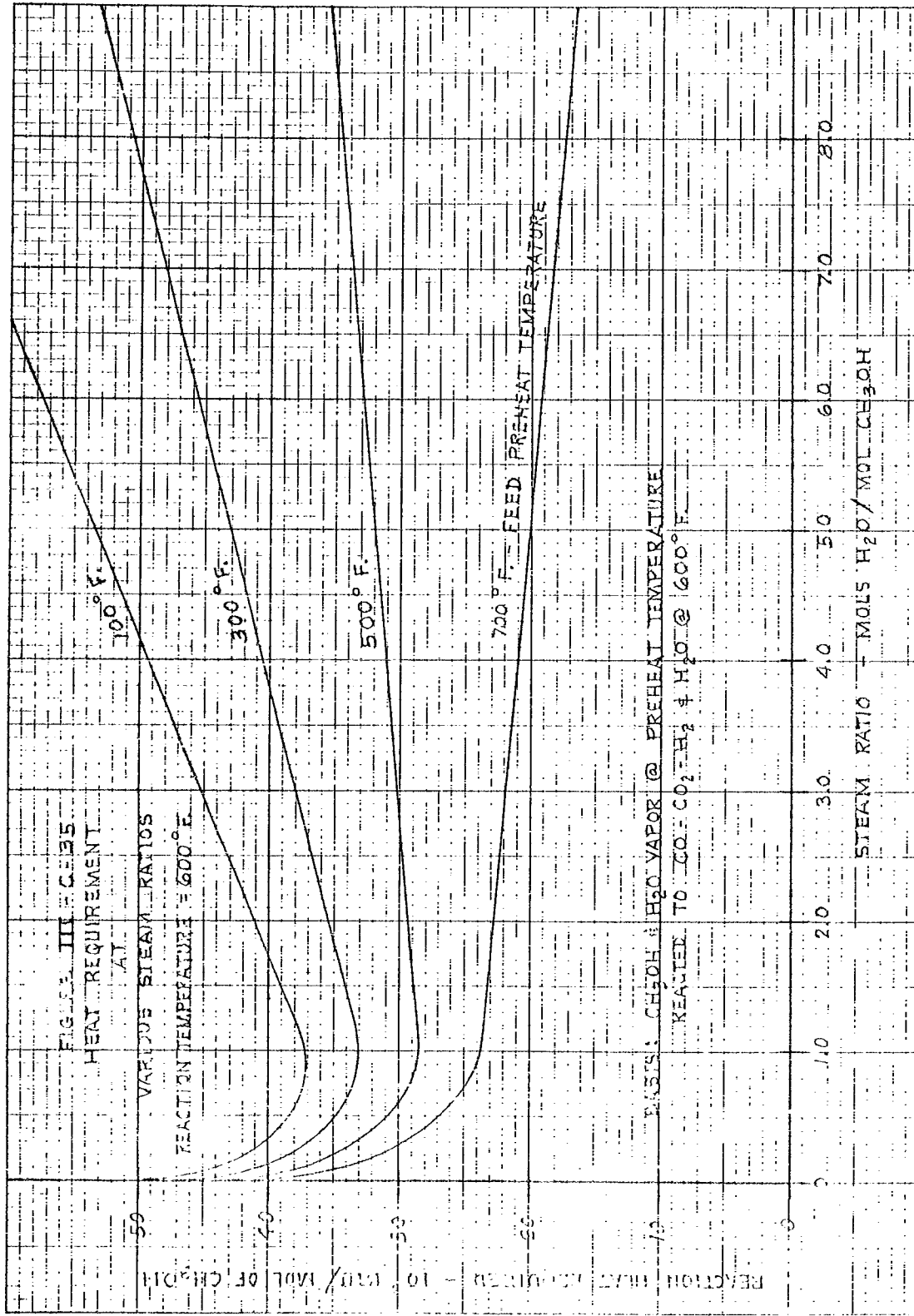

GIRDLER CORPORATION
 LOUISVILLE, KENTUCKY

FOR: BUREAU OF SHIPS
 U. S. NAVY

DRAWING NUMBER
 A-5414-III-C-35

10 X 10 TO THE INCH
 BY J. NEUFEL GLASSER CO. NEW YORK, N. Y.

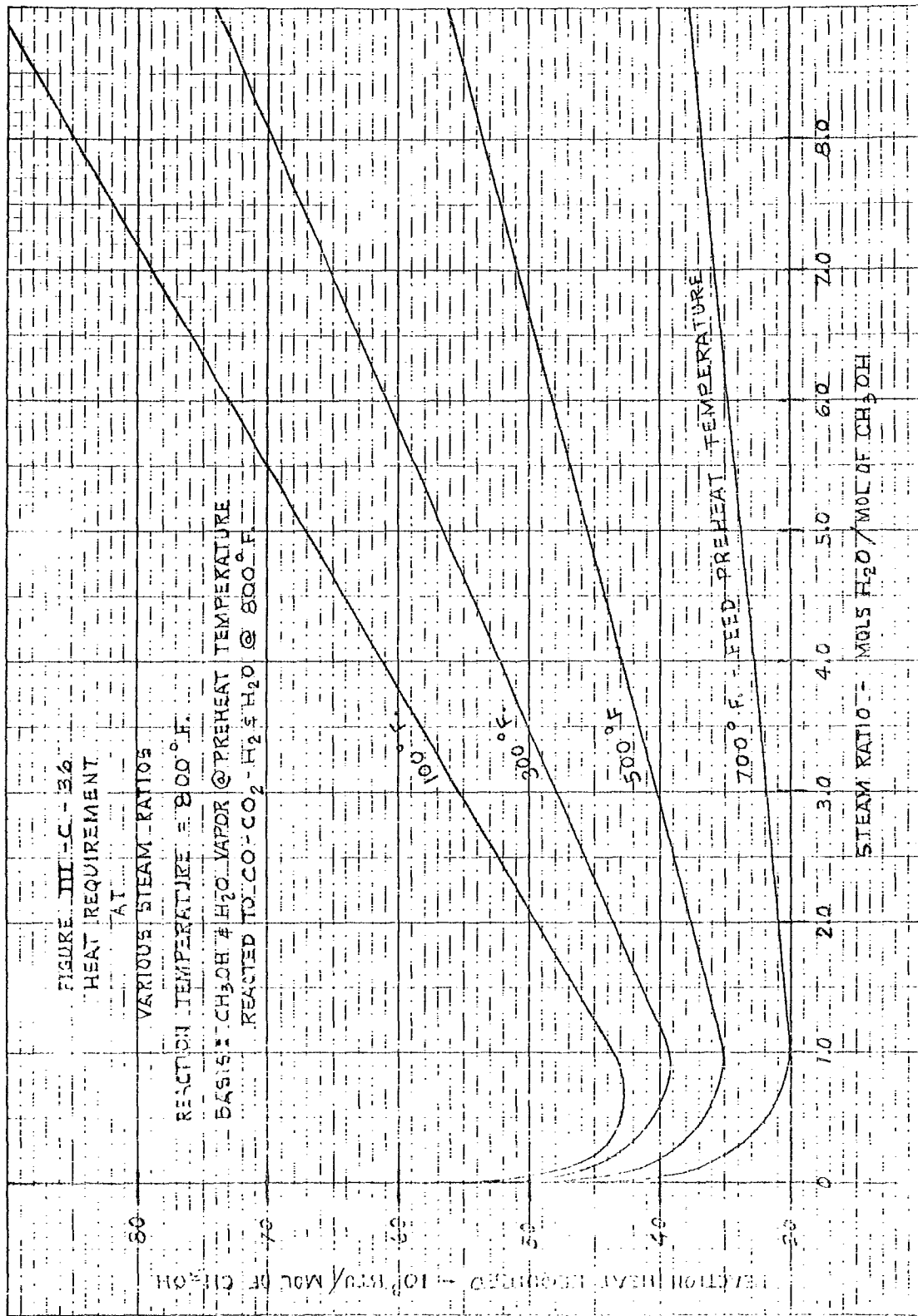

FIGURE III-C-36
 HEAT REQUIREMENT
 AT

VARIOUS STEAM RATIOS

REACTION TEMPERATURE = 800°F.

BASES: CH₃OH & H₂O VAPOR @ PREHEAT TEMPERATURE

REACTED TO CO-CO₂-H₂ & H₂O @ 800°F.

100°F

300°F

500°F

700°F. FEED PREHEAT TEMPERATURE

STEAM RATIO - MOLS H₂O / MOL OF CH₃OH

| | | |
|---|------------------------------------|-----------------------------------|
| GIRDLER CORPORATION LOUISVILLE, KENTUCKY | FOR: BUREAU OF SHIPS U. S. NAVY | DRAWING NUMBER A-5414-III-C-36 |
|---|------------------------------------|-----------------------------------|

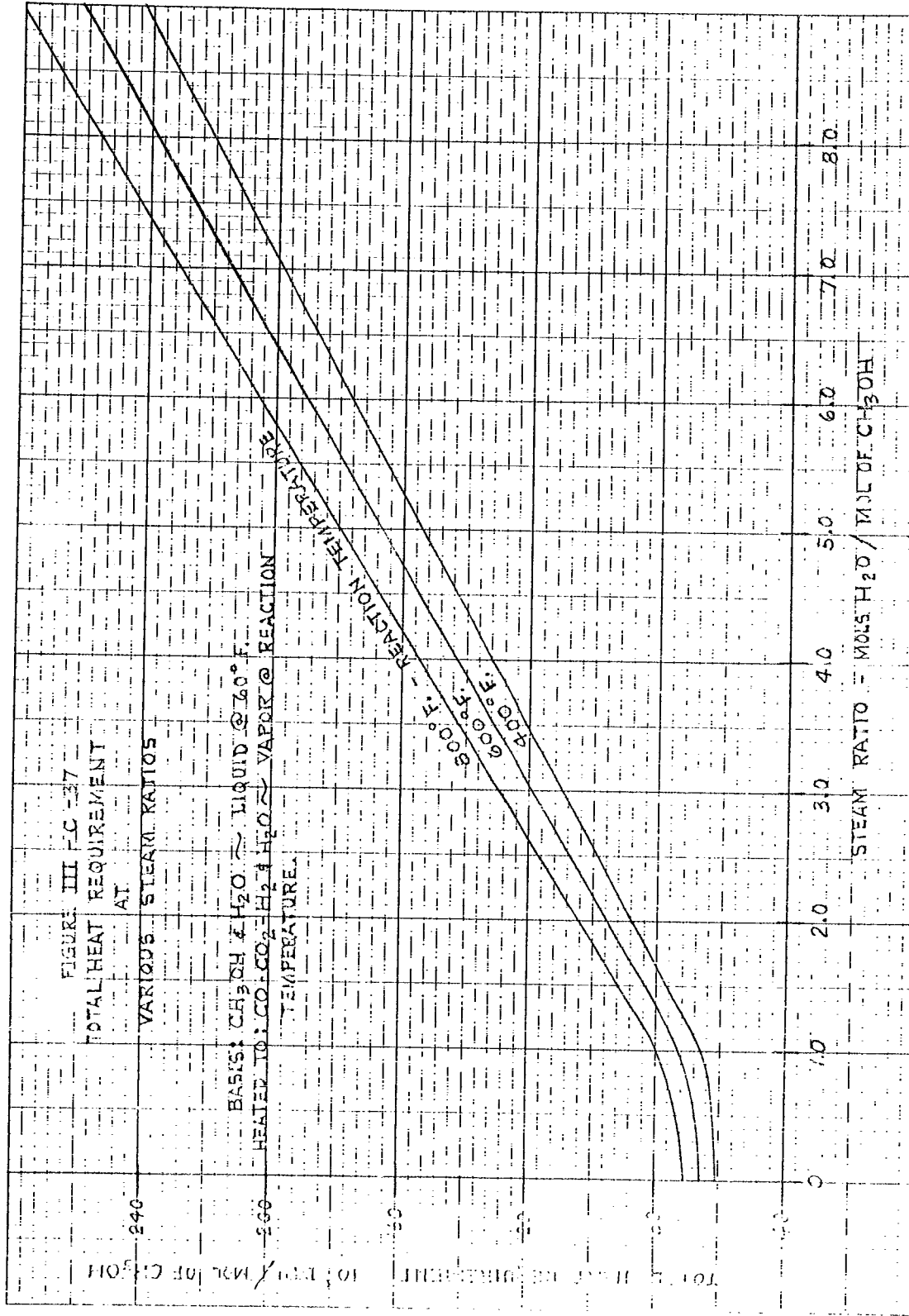

GIRDLER CORPORATION
 LOUISVILLE, KENTUCKY

FOR: BUREAU OF SHIPS
 U. S. NAVY

DRAWING NUMBER
 A-5414-III-C-37

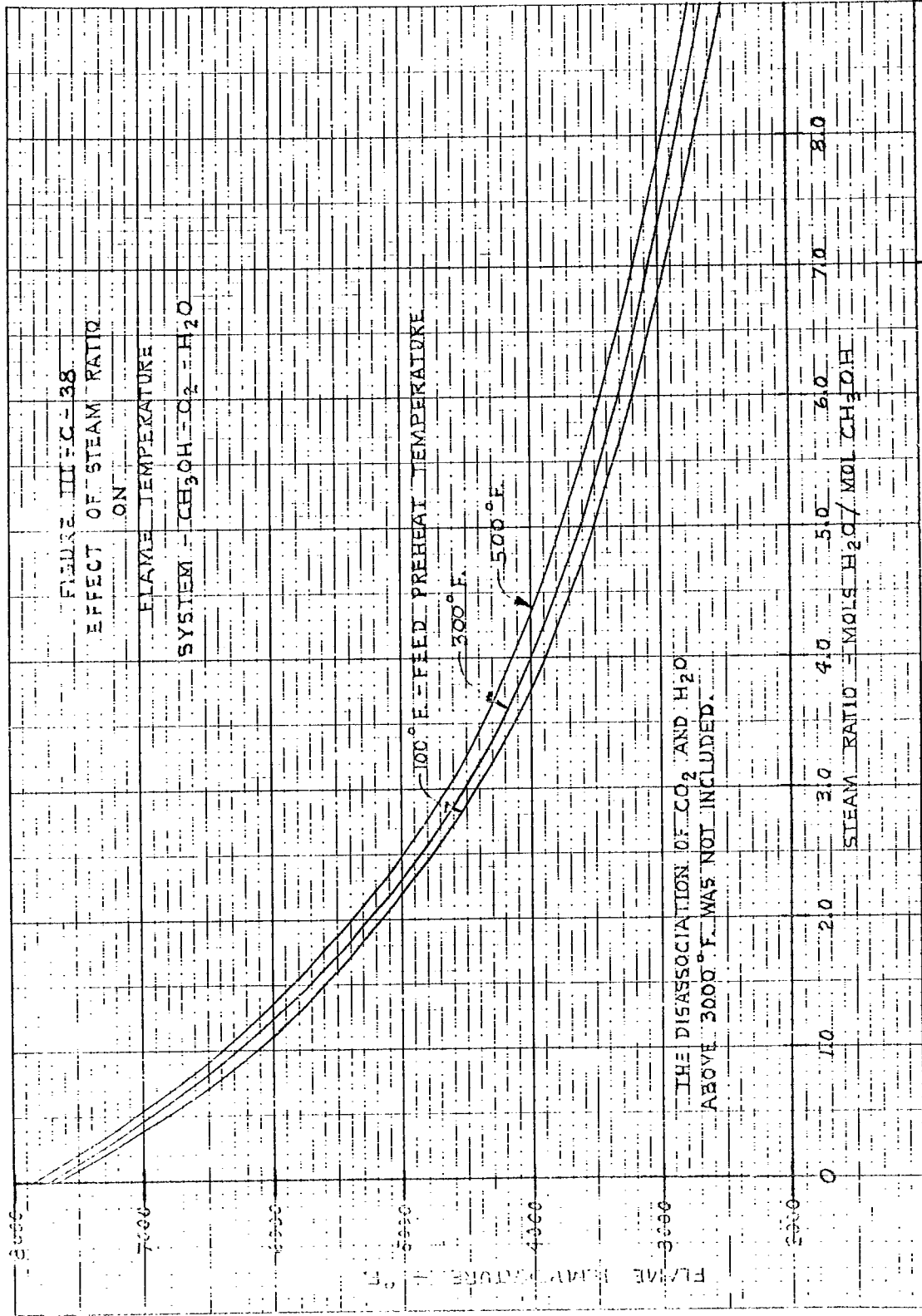

FIGURE III-C-38
 EFFECT OF STEAM RATIO ON

FLAME TEMPERATURE
 SYSTEM - CH₃OH-CO₂-H₂O

GIRDLER CORPORATION
 LOUISVILLE, KENTUCKY

FOR: BUREAU OF SHIPS
 U. S. NAVY

DRAWING NUMBER
 A-5414-III-C-38

359-SDG
 GIRDLER CORPORATION
 LOUISVILLE, KENTUCKY

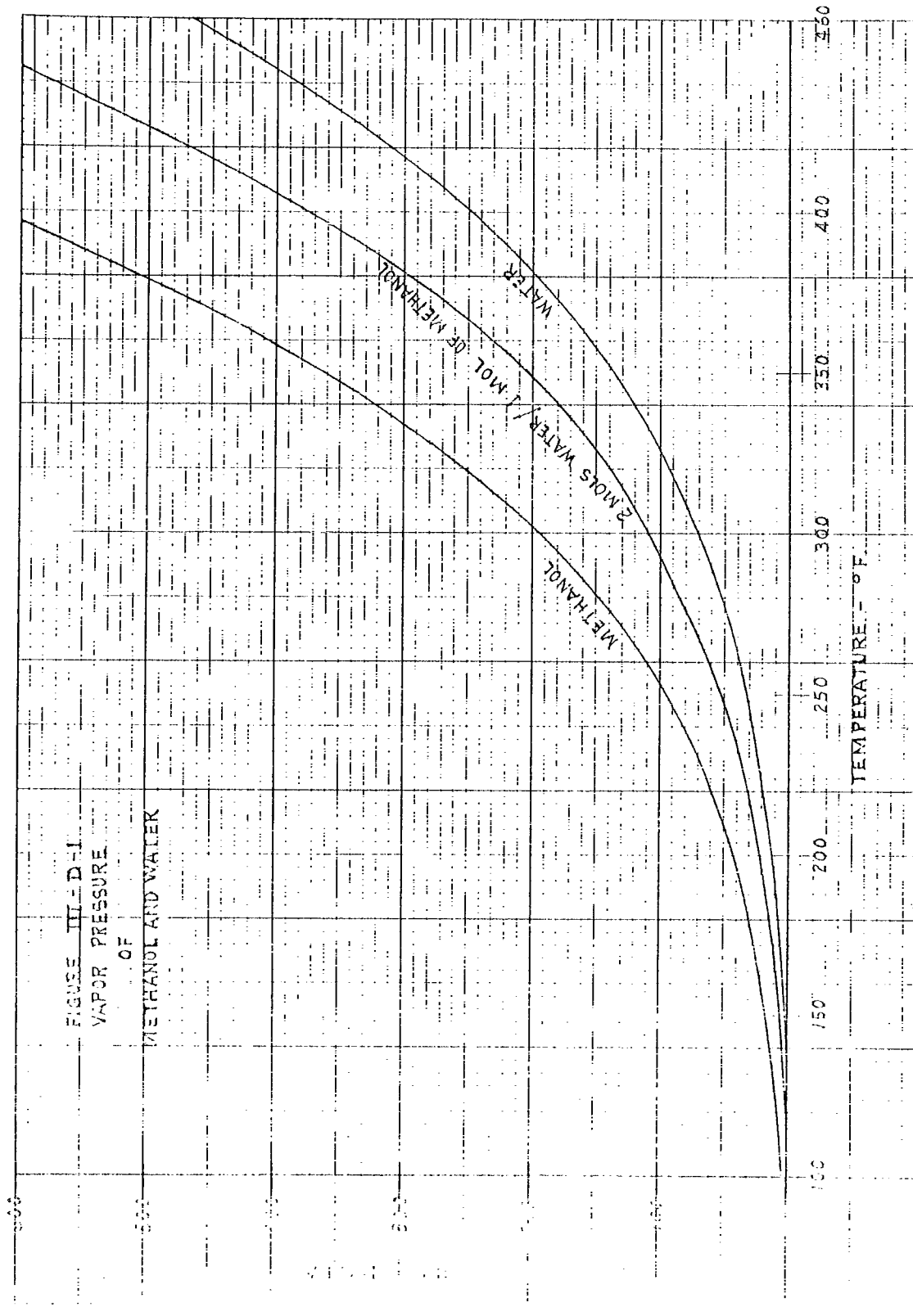

FIGURE III-D-1
 VAPOR PRESSURE
 OF
 METHANOL AND WATER

GIRDLER CORPORATION
 LOUISVILLE, KENTUCKY

FOR: BUREAU OF SHIPS
 U. S. NAVY

DRAWING NUMBER
 A-5414-III-D-1

IV. DISCUSSION OF PRELIMINARY PROCESS STUDIES

A. Adiabatic Reactor

1. Steam Ratio of 2.0:1

An adiabatic reaction is a reaction taking place in such a manner that no heat is gained or lost by the system. From a practical point of view a continuous reaction at an elevated temperature can not avoid some heat loss although this may be held to a minimum.

The reaction for the decomposition of methanol to CO and H₂ is endothermic and the reaction for the water gas shift, wherein CO and H₂O are converted to CO₂ and H₂ is mildly exothermic. For an adiabatic reaction of these materials the inlet enthalpy of the reactants must be sufficient to supply the heat required for the reaction, the heat lost to the surroundings, and the heat contained in the products at the reaction temperature. The required overall enthalpy balance is obtained by adding oxygen which reacts exothermically with reducing constituent. This results in an efficient means of heat injection since the heat is evolved in the gas stream that is to be heated.

From a study of the product composition charts (See Section III) it can be seen that the steam to methanol ratio should be approximately 2.0. The greater the steam ratio the greater would be the firing duty, cooling water load and the size of the equipment and lines. For this first study it was decided to use a steam ratio of 2.0 so that the design would result in a minimum of equipment size.

The flow diagram for hydrogen generation in an adiabatic reactor is presented in Figure IV-A. Liquid methanol and water at 60°F. are fed to a direct fired heater where the two liquids are vaporized and superheated at 450 psig. The vapors are then fed to the inlet chamber of the reactor where oxygen is added. The amount of oxygen is determined by the steam ratio, preheat temperature and reactor outlet temperature. The gas mixture then enters the catalyst bed of the reactor where the hydrogen is produced. From the reactor the gas stream goes to the purification section. The off-gas is burned in the direct fired heater for fuel. Additional heat is supplied by burning methanol with water added to keep the flame temperature within bounds. The flue gas leaving the direct fired heater consists of CO₂ and H₂O. The gas is cooled for water recovery and the CO₂ under 350 psig pressure may be ejected overboard. In an adiabatic reactor products

IV. DISCUSSION OF PRELIMINARY PROCESS STUDIES- contd.

of combustion of methanol and oxygen in the process stream leave the reactor at the reaction temperature. It is obvious that such a process has a higher thermal efficiency than a reactor in which heat is supplied from an external high temperature flue gas. The response time to rate changes is faster since the heat does not pass through tube walls which have to be heated. The reactor vessel is smaller than a tubular reformer since space is not allotted to heat transfer surface. Being under pressure the carbon dioxide is exhausted directly to the sea without further compression. Efficient use of the waste heat reduces the utility requirements. The system is basically quiet because the only rotating parts are the pumps for the fuel and raw materials.

Since some of the fuel is fired in the feed stream the quantity of combustion products in the hydrogen stream is greater. Therefore, the hydrogen purification system must be larger.

2. Steam Ratio of 4.0:1

To determine the effect of higher steam ratios on the size and number of equipment pieces a study of a 4.0 to 1 steam ratio was made. Again an adiabatic reactor was used for hydrogen generation. The fuel consumption was considerably higher than for the lower steam ratio. The purification system likewise was much larger with additional pieces of heat exchange equipment needed to remove some of the water prior to purification.

For purposes of this study it was not deemed feasible to carry further studies at this steam ratio. In the future as the design develops it may be necessary to go to higher steam ratios for technical reasons in equipment limitations.

B. Reformer

The basic equations governing the adiabatic reaction of methanol and water are also valid for reforming. In reforming the heat needed for the reaction is supplied to the reactants from an external source through the reformer tube walls. The flue gas from the combustion of the fuel does not come into contact with the reactants. Since the heat is being added as the reaction progresses there is no need to preheat the reactants to as high a temperature as in the case of adiabatic reactors. This may be an advantage since lower reactor inlet temperatures would reduce the chances of methanol cracking with subsequent deposition of carbon.

IV. DISCUSSION OF PRELIMINARY PROCESS STUDIES - contd.

The general system for hydrogen generation by reforming of methanol is shown in Figure IV-B. The feed of water and methanol, in the molar ratio of 2.0:1, is heated and vaporized under pressure in the feed preheater. The vaporized feed then passes to the reformer furnace where the reaction proceeds in the catalyst filled tubes. From the reformer the effluent process gas goes to the purification system. The off gas from the purification system is burned for fuel in the reformer. Additional heating, as required, is supplied by combusting methanol. Water is injected with the methanol to maintain the flame temperature within tolerable limits. Sufficient oxygen is supplied to convert all of the carbon to carbon dioxide. The hot flue gas, under pressure, passes to the feed preheater giving up much of its latent heat to the incoming feed. From the preheater the carbon dioxide is further cooled for water separation. The carbon dioxide being under pressure may be discharged directly into the sea.

The system consists of few pieces of major equipment. With the exception of the reformer, the equipment is small. Efficient use of waste heat results in low utility and fuel requirements. With none of the flue gas diluting the process feed the purification system size can be relatively small. The flue gases being under sufficient pressure are discharged directly overboard without compression. For deeper submergence operation a standby compressor can be installed. As with the adiabatic reactor the reformer operation would be quiet.

The reformer design is basically larger than that of the adiabatic reactor. It may not respond to rate changes as quickly.

C. Palladium Diffusion Purification

1. General

Hydrogen purification by diffusion through palladium metal is a relatively new process. The hydrogen produced is of ultra-high purity, usually having impurities less than one part per billion. The process is based on the property of palladium and particularly a palladium silver alloy to diffuse hydrogen under high pressure and temperature. According to present day technology palladium in the form of small tubes are operated at 600 to 800°F. with pressure differentials through the palladium tubes up to 400 psi. Pressures up to 1000 psig are tolerable as long as the 400 psi pressure drop across the tubes is not exceeded. The palladium alloys used are

IV. DISCUSSION OF PRELIMINARY PROCESS STUDIES - contd.

susceptible to poisoning by sulfur, carbon and unsaturated hydrocarbons. The tolerable limits of these poisons are very low. The cells can usually be reactivated by drawing a vacuum on the tubes followed by air oxidation at 800°F. Nitrogen, carbon monoxide, carbon dioxide, water, ammonia, and methane will not poison the alloy, but the presence of any gaseous constituent reduces the hydrogen partial pressure and therefore hinders the diffusion process. Methanol is not believed to be a poison but of course does reduce the hydrogen partial pressure.

The palladium diffusion purification system is compact and has a rapid response in output demand. The diffusion system itself can be turned on and off by opening or closing a valve. In considering the overall hydrogen generation facility, the response of the generation section must also be considered. When idling the diffusion cells can be kept hot with electric heaters on temperature control and can be kept full of hydrogen in order to be ready for instant operation. When pure hydrogen is desired, the flow controller is adjusted to the desired rate. The ratio flow controller simultaneously regulates the flow of purge gas.

2. Treatment of Total Crude Product

A flow diagram for the purification of crude hydrogen by diffusion through palladium alloy cells is contained in Figure IV-C-1. No prior carbon dioxide or water removal is employed.

Crude hydrogen direct from the methanol reforming step, either direct fired or adiabatic reactor, is fed to the palladium alloy hydrogen diffusion cells without removal of the carbon dioxide or water vapor. The hot pure hydrogen from the diffusion cells flows to the product hydrogen cooler. It is partially cooled in the hydrogen cooler and then is saturated with water vapor at 140°F. by bubbling through condensate in the hydrogen saturator. From the bubbler the product goes to the fuel cells.

The dilution effect of the carbon dioxide and water vapor requires the use of more palladium alloy diffusion cells than would be required if these had been removed. The magnitude of this effect can be seen in the attached figure entitled "Changes in Number of Cells Required with Hydrogen Recovery for Various Hydrogen Feed Purities," Figure IV-C-2.

IV. DISCUSSION OF PRELIMINARY PROCESS STUDIES - contd.

This figure shows how the number of diffusion cells required for producing pure hydrogen at the rate of 75 lbs/hr. changes with the purity of the feed gas and with the degree of hydrogen recovery sought. This figure is based on crude hydrogen produced in an adiabatic reactor at a 2:1 steam to methanol ratio. The data is based on operating the diffusion unit at 600°F. with a differential pressure across the palladium tubing of 200 psi.

The disadvantage of this system is the relatively high cost of the palladium alloy cells.

3. Treatment of Crude Product with Water Removed

The flow diagram is contained in Figure IV-C-3. This case is very similar to the previous case. The additional step of removing the water vapor by condensation requires the addition of heat transfer equipment. This type of equipment can be compact and can have low hydrogen holdup. An advantage of this system is the increased partial pressure of the hydrogen thus requiring only two-thirds as many palladium diffusion cells (See Figure IV-C-2) for the purification. It has the additional advantage that the condensing water vapor will remove any trace quantities of unreacted methanol. The effect of methanol vapor is felt to be that of an inert according to the J. Bishop & Co. However, the tests for methanol dilution effects were of short duration and were conducted in a dry atmosphere. This point must be cleared up by further laboratory investigation.

4. Treatment of Crude Product with Water and Carbon Dioxide Removed

This case is a further refinement over the previous case where the water vapor was removed by condensation. The crude hydrogen from the generation step is cooled by heat exchange and the water vapor condensed out. The gas is then scrubbed with monoethanolamine solution for carbon dioxide removal. The crude hydrogen is then reheated and sent to the palladium diffuser. (See Figure IV-C-4)

In this case the quantity of carbon dioxide to be removed from the crude hydrogen is about 30 to 40 times (depending on the type of gas generation system used) that removed in the present Navy unit for removing carbon dioxide from submarine atmospheres. Calculations indicate that for this carbon dioxide removal system the bed of packing alone will contain 52 cubic feet of packing, (20" Sch. 20 pipe x 26' of packing). In other words, this absorber alone would contain almost the full 900 SCF of hydrogen

IV. DISCUSSION OF PRELIMINARY PROCESS STUDIES - contd.

inventory allowed. Also, the equipment for carbon dioxide removal including absorber, regenerator, pumps, heat exchangers would require the entire space presently allocated for the complete hydrogen generation facility. Thus, from the standpoint of compactness and hydrogen inventory the separate removal of carbon dioxide does not appear practical.

In each case of purification by palladium diffusion the off gas from the cells is returned to the hydrogen generation section as fuel. It contains carbon monoxide and hydrogen both of which have heating values. The quantity of hydrogen depends upon the amount of recovery used in the diffuser cell operation. The lower the recovery used the more hydrogen in the off gas and the lower the methanol needed for fuel. However, the quantity of methanol needed for process feed to produce a given quantity of hydrogen increases with decreased recovery.

D. Purification by Low Temperature Absorption in Methanol

In the proposed hydrogen generation systems under consideration, the existence of both liquid methanol and liquid oxygen with its cryogenic cooling potential suggested a purification scheme based on low temperature absorption of carbon dioxide in methanol. A process of this type is commercially used for the purification of gas generated by coal gasification at the Fischer-Tropsch synthesis plant of South African Oil, Coal and Gas Corporation. The process as commercialized is generally known as the Rectisol process.

The Rectisol process takes advantage of the fact that carbon dioxide solubility in methanol increases with decreasing temperature and increased pressure and that regeneration of the methanol is readily accomplished by a decrease in pressure. In the commercial plant the gas stream at 350 psig is contacted with methanol at -70°F . and reduces the carbon dioxide to approximately 1.0%. The main advantage claimed for the process is lower energy consumption than other scrubbing processes such as ethanolamine or potassium carbonate. The disadvantages of the process are its complex flow scheme and relatively high vaporization loss of methanol.

In the process as considered for this study a simplified flow scheme would be used along with lower methanol scrubbing temperatures. The lower temperatures are possible due to availability

IV. DISCUSSION OF PRELIMINARY PROCESS STUDIES - contd.

of cryogenic oxygen. The use of lower temperature should result in greater carbon dioxide solubility and lower residual carbon dioxide in the product. A phase diagram of the $\text{CO}_2\text{-CH}_3\text{OH}$ system indicates that carbon dioxide is soluble in methanol up to 17 mol% at -140°F . Also, the equilibrium partial pressure of carbon dioxide should be very low at this temperature. Another factor is that vaporization loss of methanol should be very low at a lower regeneration temperature.

In the flow scheme shown on Figure IV-D, the raw gas is cooled in a heat exchanger and a water cooler to about 100°F . The gas flows through a separator to a heat exchanger where the gas is cooled to about 40°F . A small amount of methanol is added to the gas stream to prevent freeze up of the moisture still in the gas as it is cooled further in the heat exchangers which follow. The gas is cooled to about -100°F , and then flows to the methanol scrubber where it is contacted with methanol entering at -140°F . In order to maintain high absorption capacity it would probably be necessary to have chilling coils embedded in the packing so as to counteract the heat of absorption of the carbon dioxide. The gas leaving the scrubber would pass through adsorbent vessels (probably molecular sieves) for removal of the residual carbon dioxide. The cold purified gas then passes through the heat exchangers countercurrent to the incoming raw gas and finally leaves the low temperature system warmed nearly to the incoming raw gas temperature. The gas is then heated by heat exchange to about 500°F , and passes through the methanator which converts the carbon oxides to methane. The product gas would be hydrogen and methane plus trace amounts of carbon oxides.

E. Purification by Low Temperature Adsorption

The system studied here is based on increased molecular sieve capacity at lower temperatures. The adsorptive capacity of molecular sieves becomes very high for most compounds at temperatures near their normal condensation point. Thus, the capacity for carbon dioxide is increased greatly by cooling to -40 or -70°F . With cryogenic cooling available from the liquid oxygen the reduced temperatures become practical.

The simplified flow diagram is included in Figure IV-E. The system is quite similar to the previous system studied, with the methanol scrub portion being deleted. The system shown takes the gas from the hydrogen generation section and cools it by heat exchange and cooler. After water separation the gas is further dried in a dehydrator. From the dehydrator the

IV. DISCUSSION OF PRELIMINARY PROCESS STUDIES - contd.

gas is cooled by heat exchange and by liquid oxygen cooling before carbon dioxide removal in the molecular sieves. The purified hydrogen containing a small quantity of carbon oxides is warmed by heat exchange before going to a methanator. In the methanator the residual carbon oxides are converted to methane and water. The effluent gas is cooled and then goes to the fuel cells.

This system is considerably less complicated than the low temperature methanol scrubbing system. It has fewer pieces of equipment than low temperature methanol scrubbing but not as few as palladium diffusion. The control would not be exceptionally complicated. The time lag on changes of rate, though not as great as with methanol scrubbing, is not nearly as good as with the palladium diffusion cells while distinct advantage would be in the cheaper cost. The hydrogen inventory would not be excessive. Though offering a novel design this system is not felt to be competitive with the palladium diffusion cells because of equipment compactness and response time.

F. Purification by Girbotol Scrubbing and Methanation

The most conventional method for hydrogen purification considered was a Girbotol system followed by methanation. The system is based on the property of ethanolamines to absorb carbon dioxide. Upon heating, the ethanolamines give up the carbon dioxide thus being regenerated. A typical flow diagram for this process is shown in Figure IV-F. The crude hydrogen is partially cooled in a methanator preheater. It passes to the MEA reboiler where upon further cooling it gives up the heat necessary for the amine regeneration. After passing through a cooler the gas goes to the amine absorber where the bulk of the carbon dioxide is removed. The carbon dioxide is released from the amine in the regenerator, is cooled in the carbon dioxide cooler, and is exhausted overboard. In all probability a carbon dioxide compressor would be required to boost the gas to submergence pressure. The partially purified hydrogen upon leaving the amine absorber is heated in the methanator preheater and flows to the methanator. In the methanator the residual carbon oxides are converted to methane and water. After cooling the purified hydrogen is sent to the fuel cells.

Much commercial experience has been gained with this process. The system is reliable and requires a minimum of maintenance; The degree of purification is more than sufficient for fuel

IV. DISCUSSION OF PRELIMINARY PROCESS STUDIES - contd.

cell application. Efficient use is made of the waste heat. On the deficit side the size and number of the pieces of equipment are large. The inventory of hydrogen would be near 900 ft.³ for the absorber alone. The space requirements for this system would be greater than that allowed in the 580 Submarine design for the entire hydrogen production facilities. For these reasons this system was not given further consideration.

THIS DRAWING IS THE PROPERTY OF GIRDLER CORPORATION. IT IS TO BE KEPT AS A CONFIDENTIAL DOCUMENT AND NOT BE REPRODUCED, COPIED, LENT, OR DISPOSED OF IN ANY MANNER WITHOUT THE WRITTEN PERMISSION OF GIRDLER CORPORATION. ANY REPRODUCTION OR DISSEMINATION OF THIS DRAWING WITHOUT THE WRITTEN PERMISSION OF GIRDLER CORPORATION IS SUBJECT TO PROSECUTION AND PENALTY.

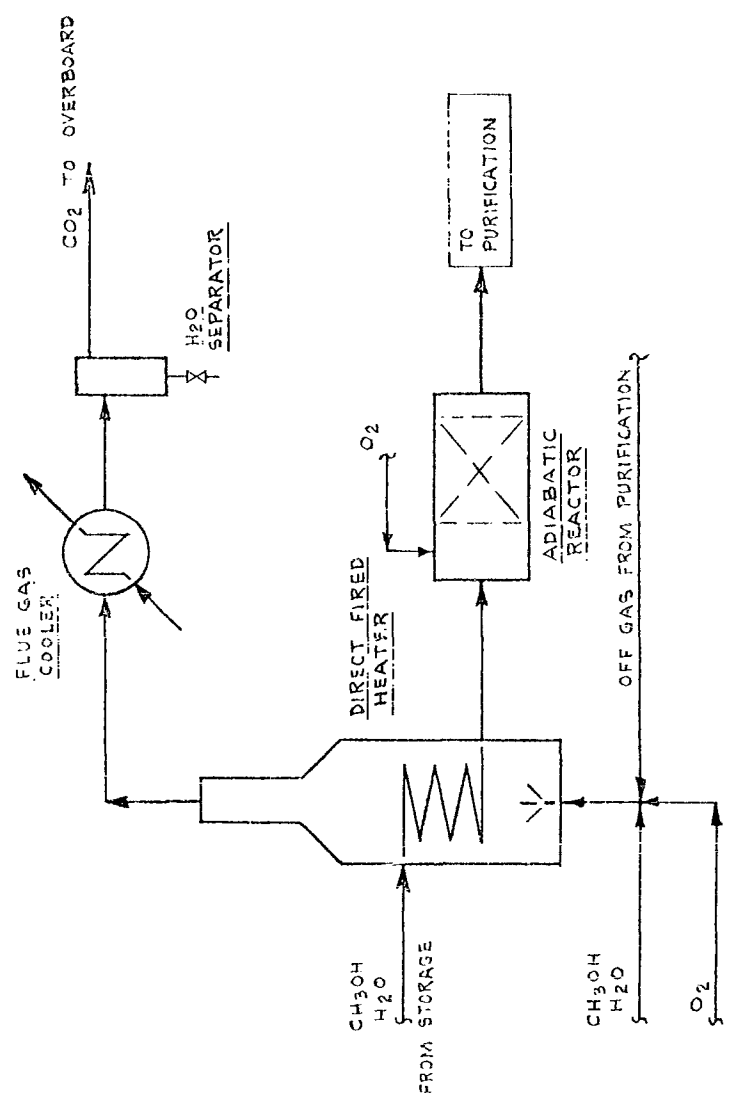

FIGURE IV - A
GENERATION OF HYDROGEN
BY AN ADIABATIC REACTOR

| NO. | DATE | REVISION | BY | CHK. | ESC. |
|-----|------|----------|----|------|------|
| | | | | | |
| | | | | | |

GC 22 11

GIRDLER CORPORATION
LOUISVILLE, KENTUCKY

FOR BUREAU OF MILITARY
U. S. NAVY

GAS GENERATION
ADIABATIC REACTOR

DESIGNED BY
A 5416 30-72

THIS DRAWING IS THE PROPERTY OF GIRDLER CORPORATION, LOUISVILLE, KENTUCKY, AND IS LENT WITHOUT CONSIDERATION OTHER THAN THE BOP, POWER'S AGREEMENT THAT IT SHALL NOT BE REPRODUCED, COPIED, LENT, OR DISPOSED OF DIRECTLY OR INDIRECTLY. IT IS SPECIFICALLY FURNISHED FOR THE USE AND PURPOSE FOR WHICH IT IS SPECIFICALLY FURNISHED. THIS PRINT IS LENT SUBJECT TO RETURN ON DEMAND.

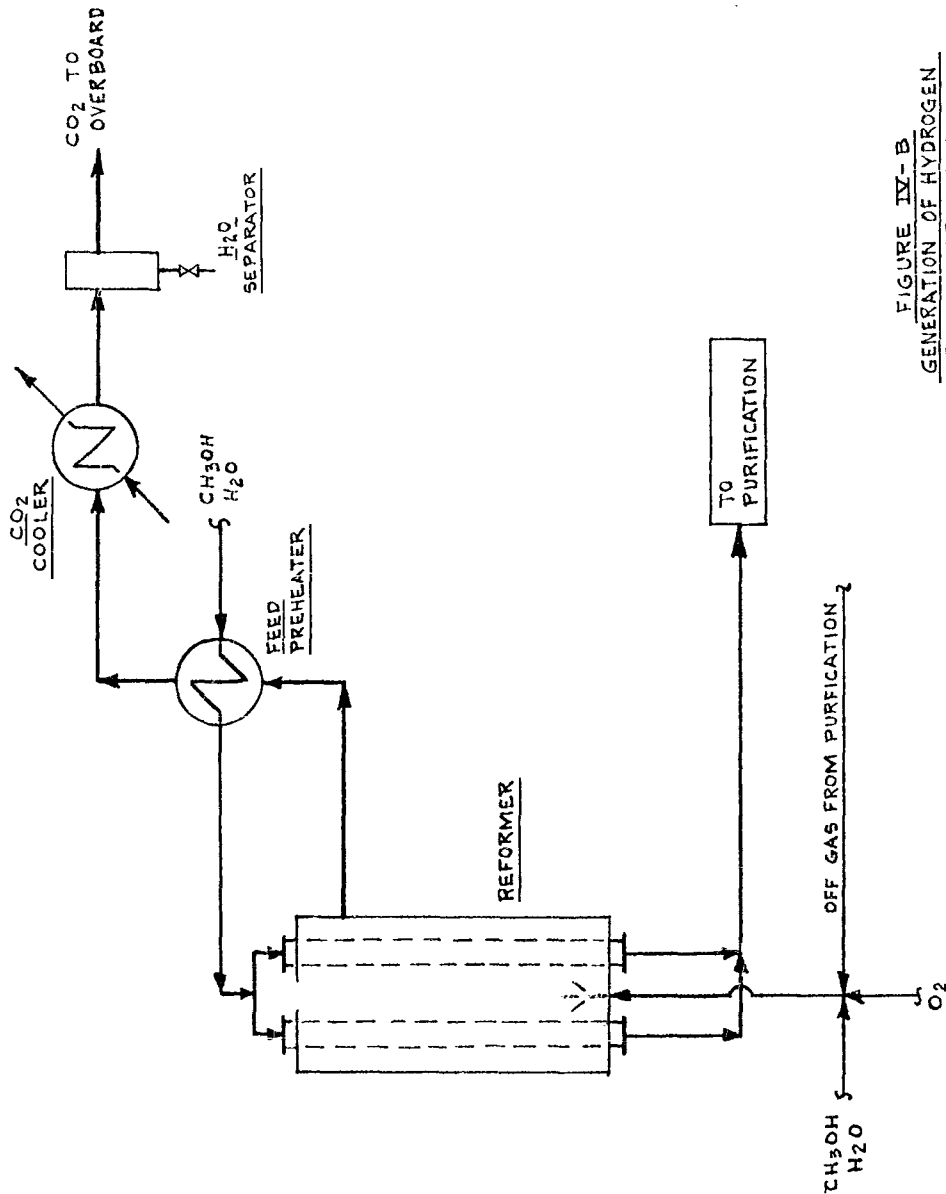

FIGURE IV-B
GENERATION OF HYDROGEN
BY A REFORMER

| NO. | DATE | REVISION | BY | CHK | ENG |
|---------|----------|----------|---------|-----|-----|
| DR. BY | J. D. W. | 8-30-62 | HEAD | | |
| CHK. BY | | | J. ENG. | | |
| DES'R. | | | | | |

GIRDLER CORPORATION
LOUISVILLE, KENTUCKY

FOR BUREAU OF SHIPS
U.S. NAVY

GAS GENERATION
REFORMER FURNACE

DRAWING NO. REV.
A-5414-IV-B 0

THIS DRAWING IS THE PROPERTY OF GIRDLER CORPORATION, LOUISVILLE, KENTUCKY. IT IS LOANED TO YOU WITHOUT CONSIDERATION OTHER THAN THE BORROWER'S OBLIGATION TO KEEP IT IN GOOD CONDITION AND NOT TO REPRODUCE, DISPOSE OF DIRECTLY OR INDIRECTLY, OR USED FOR ANY PURPOSE OTHER THAN THAT FOR WHICH IT IS SPECIFICALLY FURNISHED. THIS PRINT IS LOANED SUBJECT TO RETURN ON DEMAND.

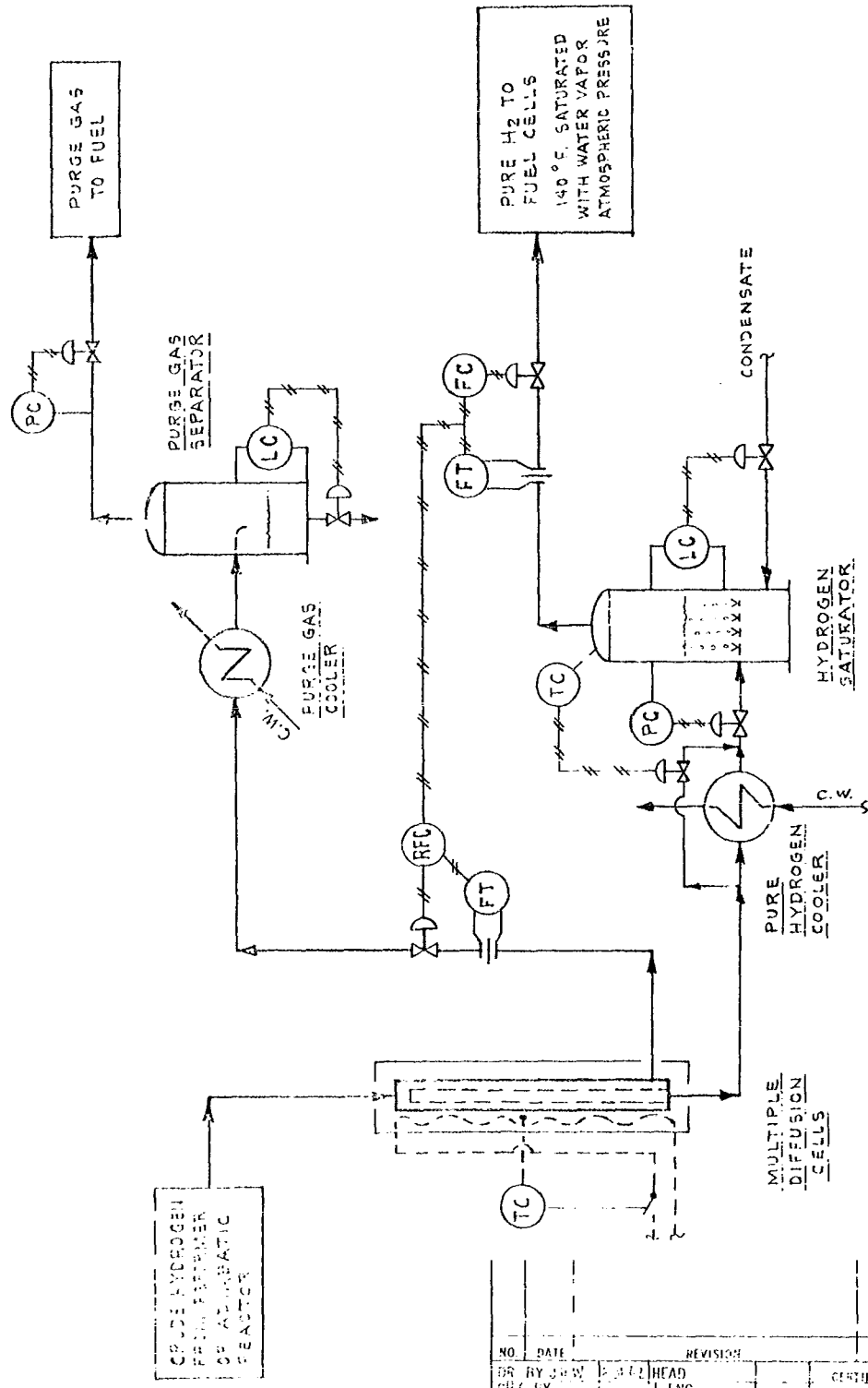

FIGURE IV-C-1
PURIFICATION OF CRUDE HYDROGEN
BY DIFFUSION THROUGH PALLADIUM ALLOY CELLS

GC 62 11

GIRDLER CORPORATION
LOUISVILLE, KENTUCKY

FOR
BY
DATE

| | | | | | |
|---|------|----------|----------------------|------|------|
| NO. | DATE | REVISION | BY | CHK | APP. |
| 1 | | | J. H. HEAD | | |
| 2 | | | J. ENG. | | |
| | | | CERTIFIED FOR DESIGN | | |
| GAS PURIFICATION PALLADIUM DIFFUSION NO PURGE GAS OR H ₂ O REMOVAL | | | DRAWING NO. | REV. | |
| | | | A-5419-17 C-1 | 0 | |

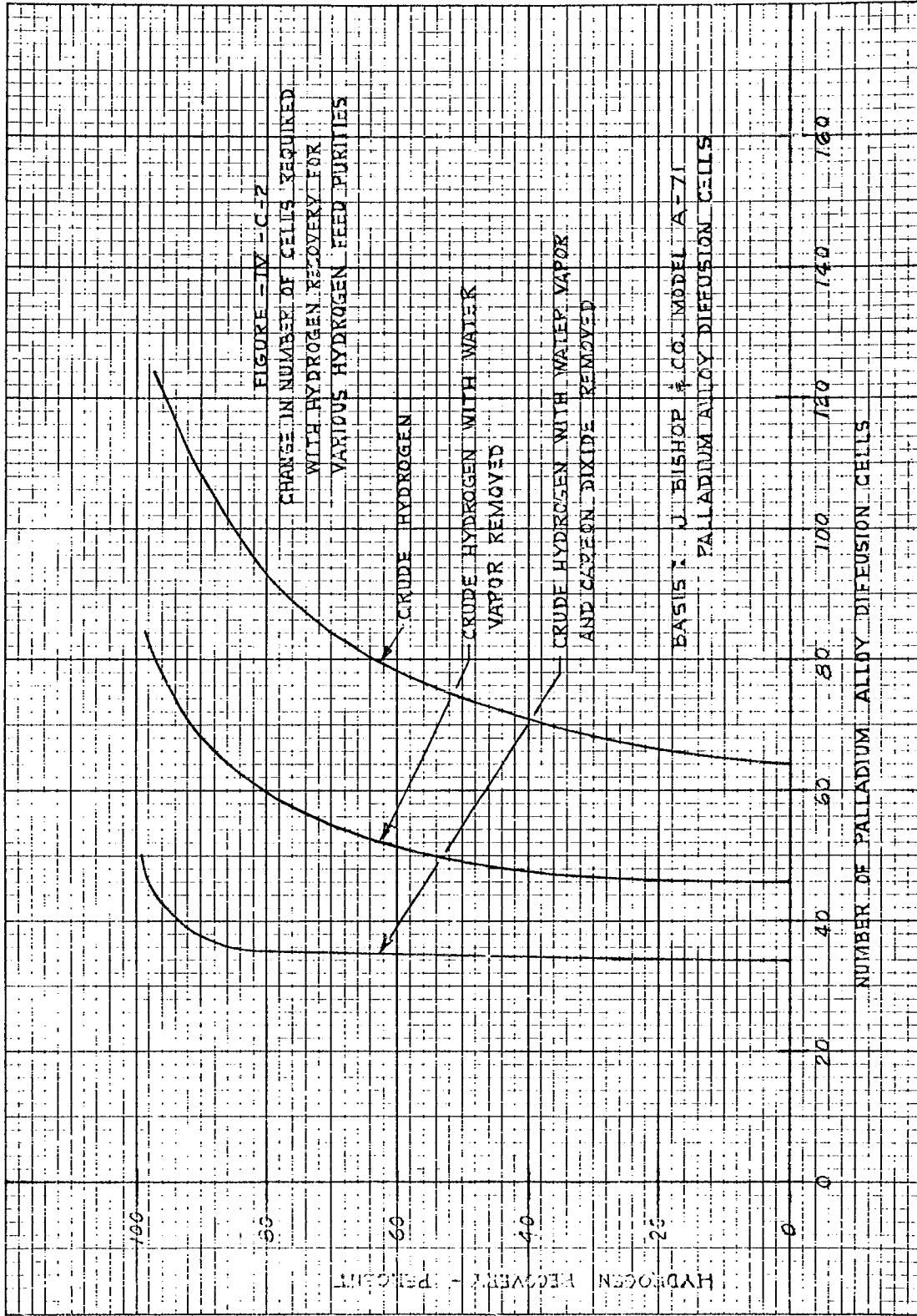

GIRDLER CORPORATION
 LOUISVILLE, KENTUCKY

FOR: BUREAU OF SHIPS
 U. S. NAVY

DRAWING NUMBER
 A-5414-IV-C-2

THIS DRAWING IS THE PROPERTY OF GIRDLER CORPORATION, LOUISVILLE, KENTUCKY, AND IS LENT WITHOUT CONSIDERATION OTHER THAN THE BORO-
 ROWER'S AGREEMENT THAT IT SHALL NOT BE REPRODUCED, COPIED, LENT, OR
 DISPOSED OF, DIRECTLY OR INDIRECTLY, NOR USED FOR ANY PURPOSE OTHER
 THAN THAT FOR WHICH IT IS SPECIALLY FURNISHED. THIS PRINT IS LENT
 SUBJECT TO RETURN ON DEMAND.

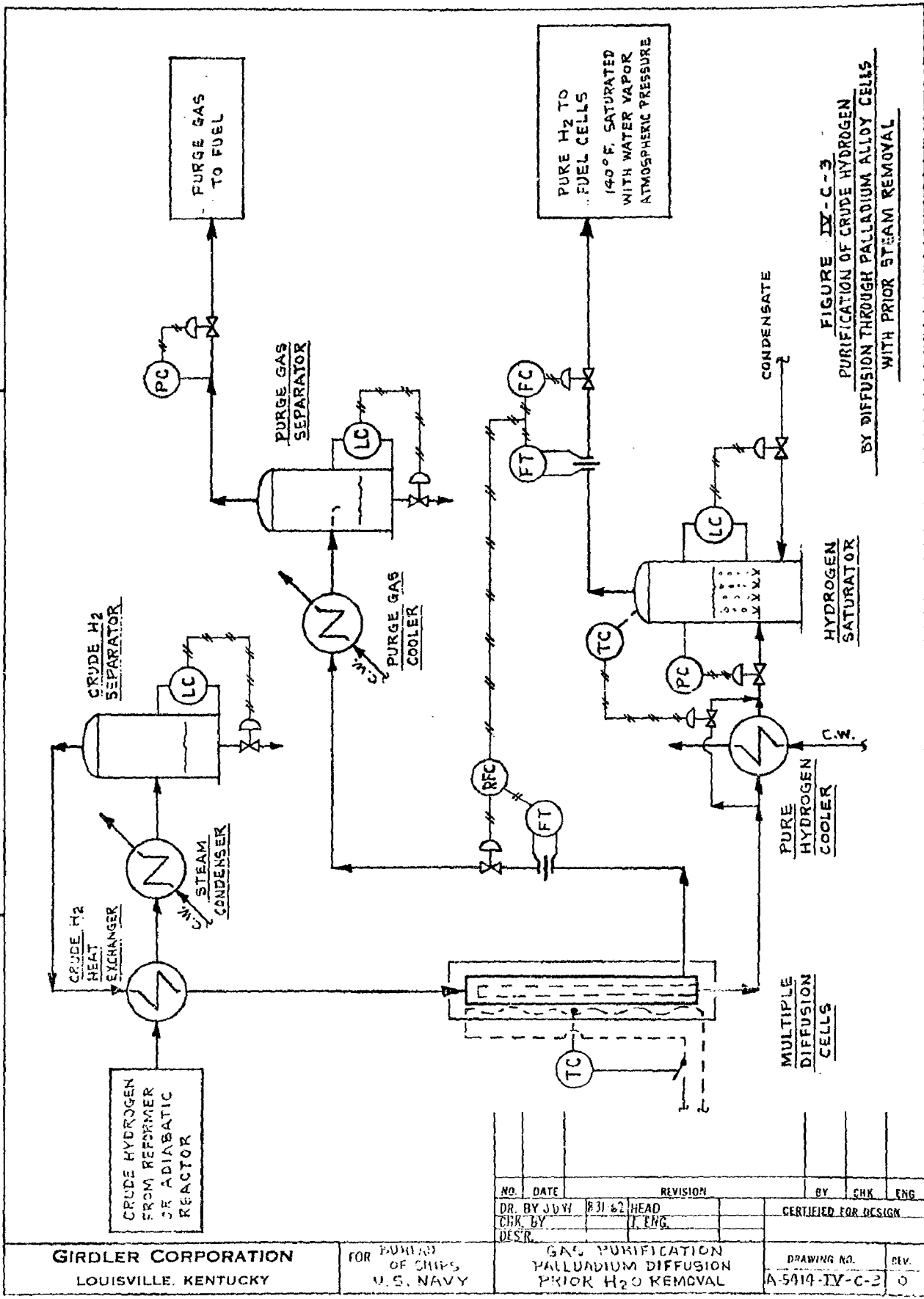

FIGURE IV-C-3
 PURIFICATION OF CRUDE HYDROGEN
 BY DIFFUSION THROUGH PALLADIUM ALLOY CELLS
 WITH PRIOR STEAM REMOVAL

| NO. | DATE | REVISION | BY | CHK | ENG |
|---|------|----------|----------------------|-----|-----|
| DR. BY | JUV | 8/31/62 | HEAD | | |
| CHK. BY | | | J. ENG. | | |
| DESR. | | | | | |
| GAS PURIFICATION PALLADIUM DIFFUSION PRIOR H ₂ O REMOVAL | | | CERTIFIED FOR DESIGN | | |
| DRAWING NO. A-5414-IV-C-3 | | | REV. 0 | | |

GC 62-11

GIRDLER CORPORATION
 LOUISVILLE, KENTUCKY

FOR PURCHASE
 OF SHIPS
 U. S. NAVY

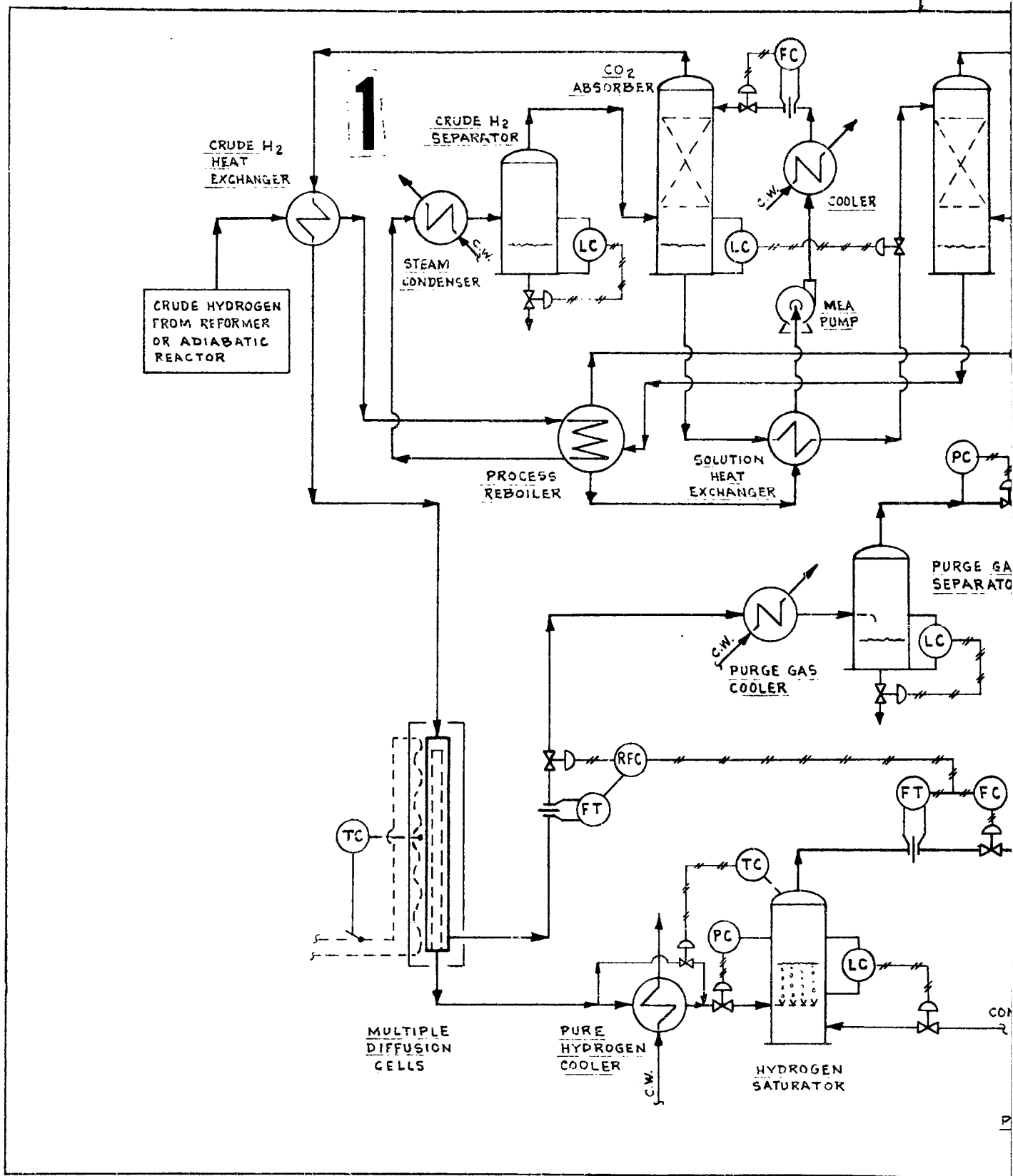

2

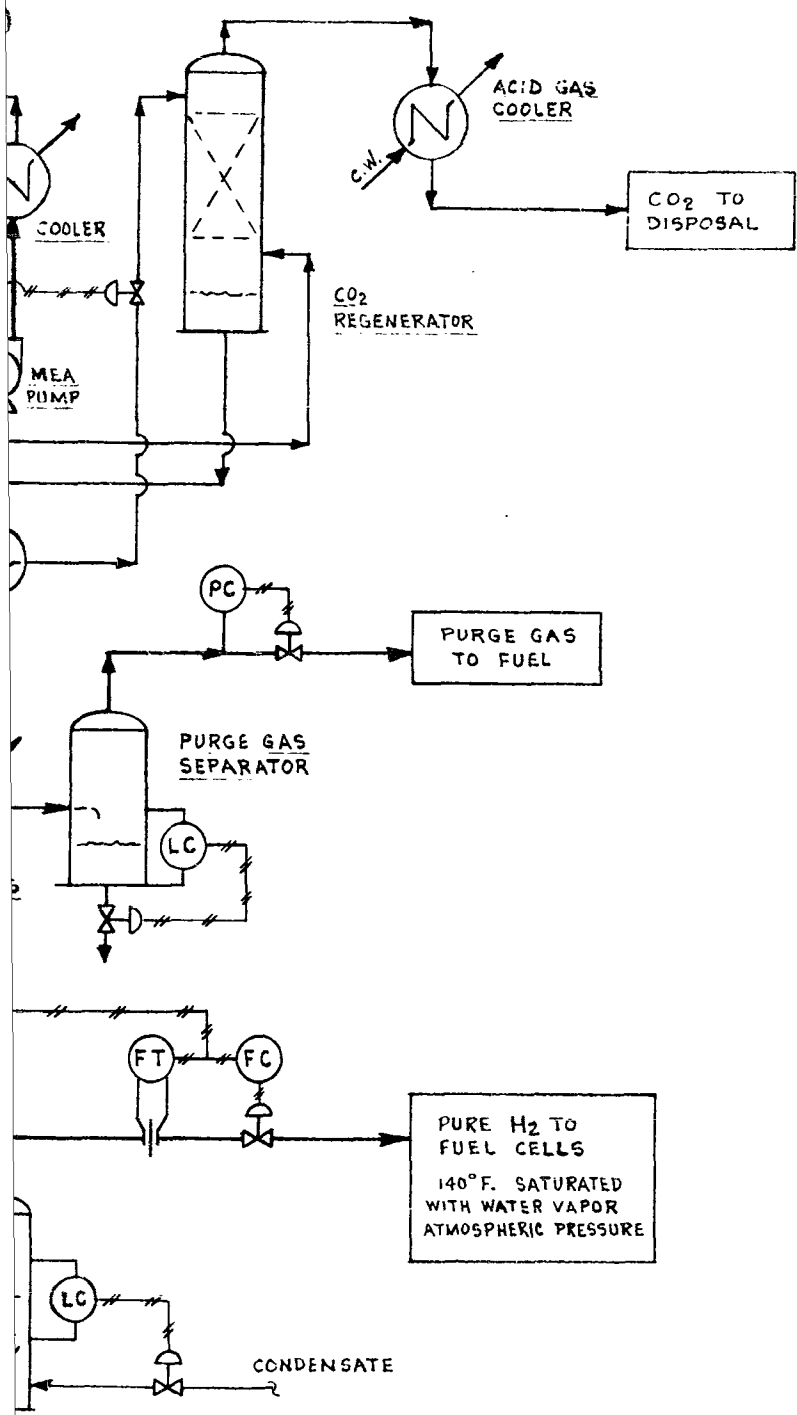

FIGURE IV-C-4
 PURIFICATION BY PALLADIUM DIFFUSION
 WITH
 PRIOR CO₂ AND H₂O REMOVAL

| No. | DATE | REVISION | BY | CHK. | ENG. |
|-----|------|----------|----|------|------|

This drawing is the property of Girdler Corporation, Louisville, Kentucky and is lent without consideration other than the borrower's agreement that it shall not be reproduced, copied, lent, or disposed of directly or indirectly nor used for any purpose other than that for which it is specifically furnished. This print is lent subject to return on demand.

GIRDLER CORPORATION
 LOUISVILLE, KENTUCKY

| | | | |
|---------|-----------------|--------------|--|
| SCALE | NONE | DESIGNER | |
| DRAWN | WILDMAN 8-31-62 | GROUP HEAD | |
| CHECKER | | JOB ENGINEER | |

TITLE:
 GAS PURIFICATION
 PALLADIUM DIFFUSION
 PRIOR CO₂ & H₂O REMOVAL

| | | |
|------------------------------|----------------|------|
| FOR: | DRAWING NUMBER | REV. |
| BUREAU OF SHIPS U.S. NAVY | B-5414-IV-C-4 | 0 |

THIS DRAWING IS THE PROPERTY OF GIRDLER CORPORATION, LOUISVILLE, KENTUCKY, AND IS LENT WITHOUT CONSIDERATION OTHER THAN THE BORROWER'S AGREEMENT THAT IT SHALL BE REPRODUCED, COPIED, LENT, OR DISPOSED OF DIRECTLY OR INDIRECTLY OR USED FOR ANY PURPOSE OTHER THAN THAT FOR WHICH IT IS SPECIFICALLY FURNISHED. THIS PRINT IS LENT SUBJECT TO RETURN ON DEMAND.

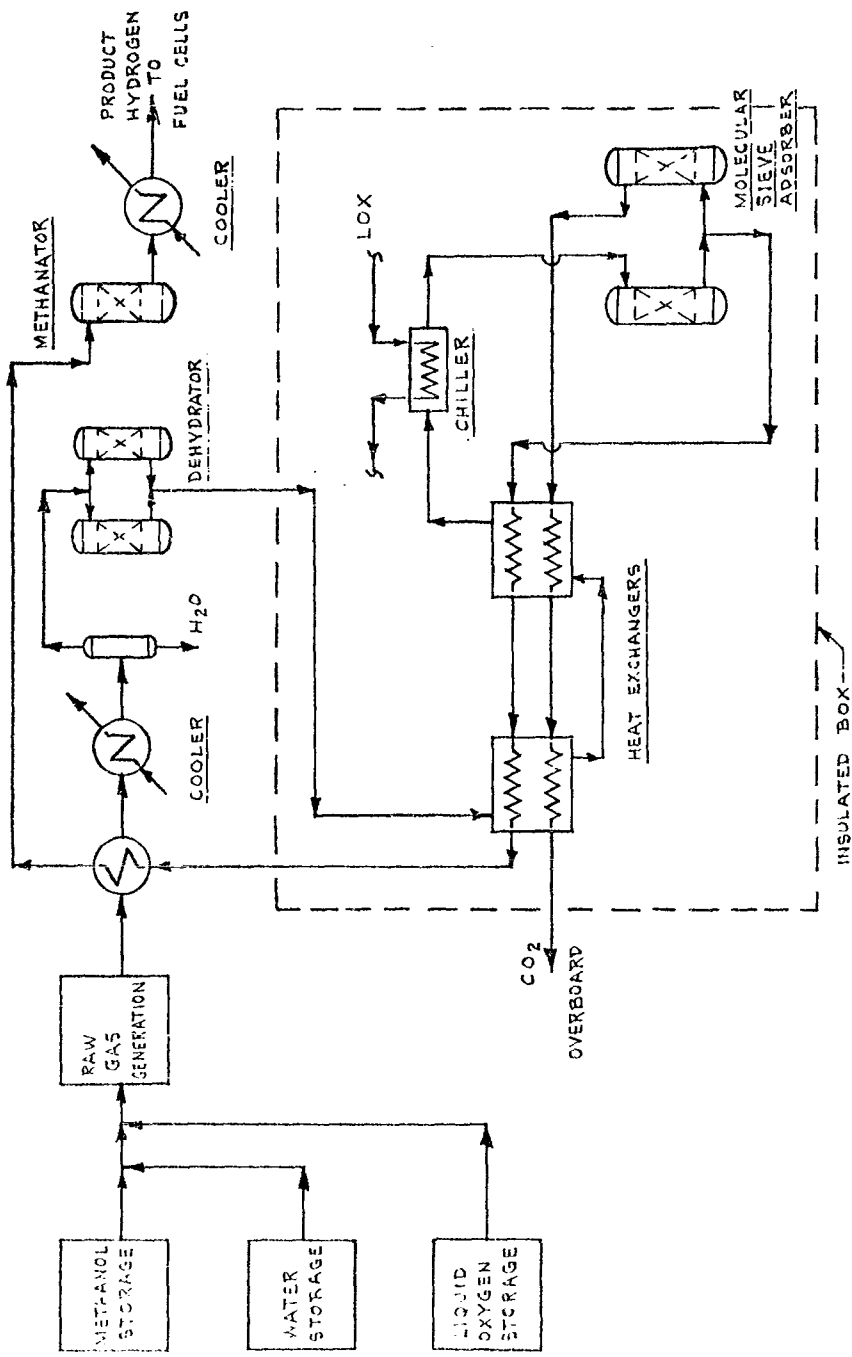

FIGURE IV-E
 PROCESS FLOW DIAGRAM
 LOW TEMPERATURE ADSORPTION PURIFICATION
 FOR SUBMARINE HYDROGEN PLANT

GC 62-11

GIRDLER CORPORATION
 LOUISVILLE, KENTUCKY

FOR OFFICE OF
 NAVAL AVIATION
 WASHINGTON, D.C.

| | | | | | |
|---------------|------|----------|-------------|------|------|
| NO. | DATE | REVISION | BY | CHK. | APP. |
| DR. BY | DATE | REVISION | BY | CHK. | APP. |
| CHK. BY | DATE | REVISION | BY | CHK. | APP. |
| DR. BY | DATE | REVISION | BY | CHK. | APP. |
| DRAWING NO. | | | REV. | | |
| 62-11-10000-1 | | | A-5414-39-E | | |

THIS DRAWING IS THE PROPERTY OF GIRDLER CORPORATION, LOUISVILLE, KENTUCKY AND IS NOT TO BE REPRODUCED, COPIED, LENT, OR DISPOSED OF, DIRECTLY OR INDIRECTLY, FOR ANY PURPOSE OTHER THAN THAT FOR WHICH IT IS SPECIFICALLY FURNISHED. THIS PRINT IS LENT SUBJECT TO RETURN ON DEMAND.

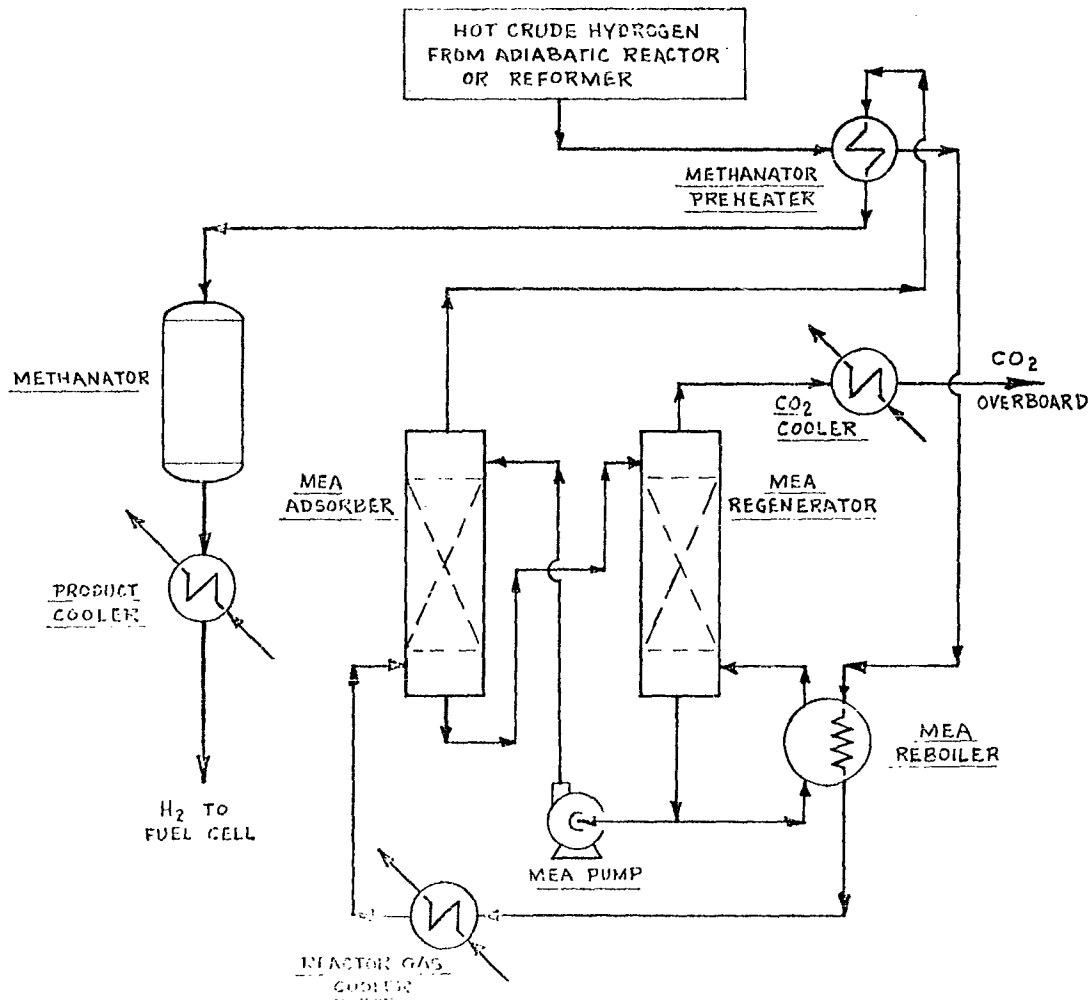

FIGURE 17-F
 MEANATOR ADSORBER APPLICATION
 FOR HYDROGEN PURIFICATION

| NO. | DATE | REVISION | BY | CHK. | APP. |
|-----|------|----------|----|------|------|
| | | | | | |
| | | | | | |
| | | | | | |

GIRDLER CORPORATION
 LOUISVILLE, KENTUCKY

V. PLANT DESIGN

A. Process

1. General

After a thorough review of the available processing steps for the manufacture and purification of hydrogen from methanol a scheme was selected for further design and study. This section of the report will discuss the selected process and will point out its advantages over the other processes studied. The process is basically a combination of proven process steps but contains several original features which make it unique. The process is regarded as workable, efficient, subject to wide output variation, quiet in operation, free of objectionable odors or waste materials, relatively free of moving parts, compact and allows variation in shape-space usage.

The process briefly comprises the following steps:

- a. Methanol and condensate pumped together at 450 psig through heat exchanger and vaporized in methanol fired vaporizer.
- b. Vaporized and superheated methanol-water mixture at 700°F. reacts over catalyst contained in annulus around tube containing hot flue gas from vaporizer. Exit temperature 700°F.
- c. Crude product flows to palladium diffusion cells maintained at 700°F. Hydrogen diffuses through the palladium and the residual gas is burned in the fired vaporizer at about 400 psig.
- d. Purified hydrogen at 5 psig flows through methanator guard chambers and is finally saturated at 140°F. for use in the fuel cell.

2. Selection of Non-Adiabatic Process

The gas generation step is essentially the basic non-adiabatic process with the hybrid feature of an oxygen assist. The non-adiabatic reforming process was selected over the basic adiabatic process for a variety of reasons. Reference to the discussion in Section IV. of this report reveals that the adiabatic process holds several attractive advantages. However, certain disadvantages along with the inclusion of several new features have led to the selection of the non-adiabatic reforming process.

V. PLANT DESIGN - contd.

A disadvantage of the adiabatic scheme is that since the reaction is endothermic the gas must be at an elevated temperature (1400°F.) as it enters the reforming catalyst. At this temperature the catalyst may not perform as it is intended and undesirable side reactions may result. For instance, the reaction of hydrogen with carbon oxides to produce methane is relatively rapid at elevated temperatures. The question of the selectivity and life of the catalyst at these temperatures is not known. The elevated temperature for the adiabatic reforming may result from either preheating or addition of oxygen directly to the process stream with subsequent partial combustion. If oxygen addition is considered, the above mentioned disadvantage can be alleviated by staging the operation. Several catalyst beds would be used and part of the oxygen would be added at each so that the maximum temperature developed would be held to predetermined limits. Catalysts are available to make such a scheme workable but the equipment and instrumentation tends to become complicated. Likewise, if an adiabatic system using preheating were to be carried out in stages the equipment would become bulky and complicated.

A further disadvantage of an adiabatic process using partial combustion of the process material to supply the reaction heat requirements is that the carbon dioxide and water vapor thus produced remain in the process stream and reduce the hydrogen partial pressure. In the process selected the raw hydrogen stream goes directly to the palladium diffusion cells. The lower hydrogen partial pressure increases the number of palladium cells required. This was illustrated in Fig. IV-C-2, where it is shown that the number of cells required increases as the amount of impurities in the raw stream increases.

An advantage that is usually claimed for adiabatic reactions is that no space allowance need be made for heat transfer surface. In this particular system the vaporizing and heating up to 700°F. of the reactants amounts to approximately 70% and the heat duty for the reaction is approximately 30%. Since the reaction heat requirement is relatively small, the advantage gained by an adiabatic system by eliminating heat exchange surface for this duty is also relatively small.

In the design selected, the heat is added to the process stream more or less continuously from the point of feed

V. PLANT DESIGN - contd.

introduction to the completion of the reforming reactions. By this scheme, the methanol burned as fuel, first gives up heat to vaporizing and superheating the feed, and then gives up heat to the reaction as it progresses. The hot flue gas stream passes through the inner tubes of the reactor so the outside of the reactor gets no hotter than the process stream. At no point in the process is the process stream heated much above 700 or 800°F. This is desirable from the mechanical design point of view and also reduces the need for high temperature insulation. As pointed out previously the desired reactions are favored by temperatures in the region of 700°F.

3. Selection of Concentric Tube Design

The selection of a non-adiabatic process requires that a reactor be designed to contain the required amount of catalyst and provide for adequate heat transfer from the hot flue gas to the reacting gases. In addition, a feature not ordinarily required in this type reactor, is that both the process and the flue gas streams are to be at high pressure (about 400 - 450 psig.).

The usual non-adiabatic reactor or reformer for hydrogen production comprises a rectangular fire brick lined combustion chamber through which passes the required number of catalyst filled tubes. The length and diameter of the tubes are adjusted to give the desired balance of heat transfer area and reaction space velocity consistent with the required process operating pressure. The tubes are usually 2 to 8 inches in diameter so that the maximum heat transfer distance is small and good control of the reaction is possible.

The disadvantage of this type reformer lies in the necessity for designing the combustion chamber for 400 psig. Consideration of this problem led to the possible use of a shell and tube heat exchanger design. The exchanger would be a fixed tube sheet design with expansion allowance in the shell. The catalyst was to be contained in the tubes and the hot gases were to flow through the shell. Such a design along with the alternate of putting the hot gases in the tube and the catalyst in the shell held possibilities but the design for the expansion in the shell due to the hot flue gases (about 1600°F. inlet) became cumbersome.

V. PLANT DESIGN - contd.

A further modification of the shell and tube design was to use a double pipe arrangement or concentric tubes. In this design the catalyst is to be in the annulus and the hot gases will flow through the center. The expansion will be taken in the shell but in this case the metal temperature will be approximately 700°F. or nearly the same as the reaction temperature. Under these conditions the mechanical design becomes reasonable.

In the proposed design it is planned to run the flue gas countercurrent to the process gas flow. The flue gas will enter at about 1600°F. and leave at about 800°F. The process feed will enter at 700°F. and the products will leave at about 700°F. The advantage gained is that the hot flue gas will not be in thermal contact with the methanol feed, and the possibility of thermal cracking is eliminated.

The proposed reactor is made up of an inner pipe 2 inches in diameter and an outer pipe 4 inches in diameter with approximately 10 feet 6 inches of catalyst. Multiple units would be required for the plant under consideration. An important advantage for this design over others considered is that the reactor tubes can be arranged in a variety of ways to suit the space-shape available.

It is proposed that the reactor tubes and the manifolding be enclosed in an insulated box, possibly comprising a thin walled chamber with the interior filled with a granulated insulation. Such a reactor unit should have low heat loss and should be very resistant to shock.

Ease of scale-up of the design capacity is another advantage of the proposed design. More units could be added to the system without major modifications to the layout. If valves are provided, capacity control could be exercised by altering the number of tubes on-stream. Tubes that are off-stream are maintained at operating temperature and could be started quickly.

As stated previously, the raw hydrogen gas flows from the reactor directly to the palladium cells. Eight palladium cells are required to handle the raw hydrogen product from each concentric tube reactor. It is fortuitous that the optimum operating temperature level of the palladium cells is 600 to 800°F. While it is not necessary to add heat to

V. PLANT DESIGN - contd.

the palladium cells, it is necessary to maintain them at operating temperature. It was logical to propose coupling eight palladium tubes arranged in a circle about a reactor tube and enclosing the whole unit in the insulated box. This results in considerable space savings and is a distinct advantage for the proposed design.

4. Selection of Palladium Diffusion Purification

The raw hydrogen gas from the reactor tubes will contain approximately 55% hydrogen, 16% carbon dioxide, 25% water vapor, 4% carbon monoxide with small amounts of methane, and methanol. A number of processes were reviewed for the purification of this gas and these were discussed in Section IV of this report.

The most common purification scheme would be the use of cooling to remove water vapor, and unreacted methanol scrubbing with monoethanolamine or hot carbonate to remove carbon dioxide and methanation to convert the carbon monoxide and residual carbon dioxide to methane. The final product would be hydrogen containing approximately 5% methane and less than 10 ppm carbon oxides. This gas would be satisfactory for fuel cell operation although higher purity is desirable. A process based on amine scrubbing has many advantages including the fact that wide experience has been gained on this process in actual submarine operation. However, the process requires too much space, too many pieces of equipment, is subject to upset when not perfectly level and would have an inventory of hydrogen in excess of the volume allowed on board the submarine. For these and other reasons the process was not selected for this service.

The use of molecular sieves or other adsorbent material at low temperature for removal of carbon dioxide in place of the amine scrubbing process was considered. This scheme eliminates circulating liquids and reduces the inventory of hydrogen but involves considerable equipment. Also, it requires alternate use and regeneration of both a desiccant bed and the molecular sieve. This is a disadvantage since it would require intermittent venting of the off-gases. The low temperature process requires the use of close approach exchangers between incoming

V. PLANT DESIGN - contd.

and outgoing streams. Such a system is not adaptable to rapid changes in rate as are required for the submarine service.

The use of low temperature methanol scrubbing for carbon dioxide removal was considered. The process has a number of attractive features such as the use of methanol as the scrubbing medium, thereby eliminating the need of other chemicals, and low energy consumption due to the use of liquid oxygen as the collant. However, the process has the disadvantages of liquid scrubbing and low temperature systems as noted above.

The use of palladium diffusion was the other scheme considered and was the one selected. A variety of reasons for this selection are apparent. The diffusion cells differ from the other systems considered in that a pure hydrogen stream is produced whereas the other schemes produced 95% hydrogen. The palladium cells involve no chemicals or fluids, are not subject to corrosion, require no auxiliary pumps or heat exchangers during normal operation, are perfectly quiet, produce no troublesome wastes, require no extra utilities, involve no excessive temperatures or pressures, operate at the same temperature as the reforming reactors, may be operated at any angle, give instantaneous response, may be operated over an extreme range of through-put always yielding a pure product. In addition, the cells are not subject to poisoning by the gases encountered in this process and they should give a long service life.

The diffusion of hydrogen through palladium is directly proportional to the partial pressure driving force of hydrogen. The presence of water vapor or carbon dioxide in the raw gas has no detrimental effect on the diffusion process other than as a diluent. Consideration was given to operation of the palladium cells with and without prior removal of the carbon dioxide and/or water vapor. Reasons for not removing carbon dioxide by any scheme other than the palladium cells have been adequately covered above. Since water vapor constitutes about 25% of the raw gas stream from the reforming reactors, a reduction of about one-third in the number of palladium cells could result by water removal. The gas stream would have to be cooled to condense the water and then reheated to the operating temperature of the palladium cells. The gas cooling and reheating would be done in a gas to gas heat exchanger and the final cooling

V. PLANT DESIGN - contd.

and condensing would be done with cooling water. There would be a considerable cost savings in this scheme. However, the added space requirements and the operational lag in the heat exchangers ruled out water removal for this system.

5. Pressure Level of Operation

In the proposed design the process stream is vaporized and reacted, and flows to the palladium diffusion cells at pressures of 425 to 430 psig. The purified hydrogen flows from the palladium cells at 5 to 10 psig and finally to the fuel cells at 1 to 2 psig. The combustion in the vaporizer takes place at 350 to 400 psig and the flue gases flow on through the concentric tube reactors, the liquid feed preheater and flue gas cooler at this pressure.

On the process side a number of advantages are gained by high pressure operation. The rate of diffusion of hydrogen through the palladium is favored by the increased hydrogen partial pressure driving force. Higher pressure operation makes possible a higher space velocity through the reforming catalyst. Also, the higher pressure results in smaller and more compact equipment.

From a process heating standpoint, the combustion could have been carried out at atmospheric pressure. However, the necessity of disposing of the carbon dioxide produced in the fuel and purge gas combustion indicated an advantage for the high pressure operation. Two methods of carbon dioxide disposal exist. It can either be liquified and stored under pressure using liquid oxygen refrigeration or it can be expelled from the submarine at a pressure in excess of the submergence pressure. Either method would require the carbon dioxide under elevated pressure. It was considered more desirable to pump the fuel to the high pressure and design for the high pressure flue gas then to provide a compressor. The carbon dioxide rate will vary widely and compressor design and control could be very difficult. Also, the pump should be quieter in operation than a compressor.

6. Oxygen Addition for Process Assist

One of the most important requirements of the hydrogen production unit for submarine operation is an ability to increase the rate rapidly. Under proper computer control, signals can be transmitted to the various pumps and control instrument almost instantaneously upon receiving

V. PLANT DESIGN - contd.

a command for an increase in rate. It has already been pointed out that the palladium diffusion cells will respond quickly to a change of rate. Likewise, the reforming catalyst is capable of handling a sudden increase in rate provided the heat requirements are satisfied. The slowest response would be expected from the vaporizer. Even though the fuel rate is increased this unit will tend to lag due to the heat capacity of the vessel and insulation.

It is expected that, as the result of a command to increase rate, the vaporized feed to the reformer would drop in temperature. Likewise, there would be insufficient heat in the catalyst and the net production of hydrogen would not increase immediately. The inability to transfer heat into the process stream, therefore, limits the rate of increasing hydrogen production. For this reason, it was considered desirable to introduce oxygen directly into the process stream just ahead of the reformer. At this point a catalytic partial combustion would take place supplying the required heat for reforming at the increased rate. As the heat supplied from fuel combustion increases the oxygen injection would be cut back. This scheme may also be used to extend the capacity of the unit beyond the normal design capacity.

With this scheme the catalyst is required to promote a number of reactions simultaneously - oxidation, decomposition of methanol and water gas shift reaction. An indirect approach would be to combine the oxygen with a portion of the feed stream in such a ratio that the burning reaction would proceed non catalytically and then combine the hot product gases with the remainder of the feed and proceed with the reforming reactors. However, there is reason to believe that all the reactions can be carried out catalytically on a common reactor with either a single multipurpose catalyst or a multibed arrangement of different catalysts. This would result in a simpler and more flexible system.

V. PLANT DESIGN - contd.

7. Discussion of Flow Diagram

The process flow diagram for the hydrogen plant is shown on Figure No. V-A-1. The equipment consists essentially of an aqueous methanol feeding system, a feed preheater and vaporizer and a reformer or catalytic reactor in which crude hydrogen is produced by the chemical reaction of methanol vapor and water vapor at moderately elevated temperatures, (700°F., 425 Psig.). This is followed by palladium diffusion purification, a guard methanation chamber and a gas saturator.

The commercially pure methanol, approximately 99% CH₃OH, flows from storage to the suction of a metering feed pump of the reciprocating type. The pump has provision for varying the stroke and also has a variable speed drive to accommodate the wide range of turndown from maximum capacity to minimum capacity. Process condensate or mineral-free water flows from storage to the suction of a similar metering feed pump also provided with variable stroke and variable speed drive.

The primary control of the rate of hydrogen production at constant reaction conditions of temperature and pressure is the speed of the process methanol and condensate pumps which is regulated by a signal from the main computer control center which governs the pump drive speed. In the event of a failure in the control center, the pump speed can be controlled by a manual loading station.

Process methanol and condensate feed pumps of currently available designs are believed to be adaptable to the service of the hydrogen generator with suitable modifications to meet noise and shock test requirements. The variable speed drive may be developed on the principle of purely electrical control such as by direct current motor drives or on the principle of hydraulic drive transmission and control.

The streams of liquid methanol and condensate discharged from the feed pumps merge and flow to a methanol feed preheater of conventional shell and tube exchanger design. The aqueous methanol flowing within the tubes is heated by exchange with hot flue gas flowing in the shell side. The tubes, shell and miscellaneous metal parts are type 304 stainless steel. The aqueous methanol is heated to approximately 350°F.

V. PLANT DESIGN - contd.

The preheated liquid flows to a fired type shell and coil type vaporizer. The vaporizer consists of a stainless steel coil mounted inside a stainless steel pressure vessel provided with an insulating refractory lining and is fitted with a fuel burner at one end. The fuel consists of purge gas from the purifier cell unit plus sufficient methanol to maintain prescribed reactor temperature conditions and is completely burned with oxygen in the combustion chamber space to form carbon dioxide and water vapor. The process feed stream of aqueous methanol is completely vaporized within the coil and is superheated to reaction temperature levels of 700°F. to 800°F. To supply oxygen for combustion of fuel in the methanol feed vaporizer, liquid oxygen from the main liquid storage flows to the suction of a high pressure pump. This pump is located preferably in or near the oxygen storage vessel because of suction liquid conditions. The liquid oxygen is pumped to an oxygen vaporizer. The oxygen vaporizer is a double-pipe heat exchanger with the relatively small quantity of heat required for vaporization provided by circulating cooling water. The water flow is at high velocity and turbulent flow conditions inside the exchanger core pipe to prevent build-up of ice layers which would form if thin films of water were allowed to be cooled below the freezing point. The outer or shell-side pipe, and the core or tube-side pipe are both constructed of stainless steel suitable for the condition of low temperature (minus 297°F.) dictated by the liquid oxygen supply.

The mixture of methanol vapor and water vapor flows from the feed vaporizer to one of a group of 8 reformer tubes arranged in parallel flow. The methanol and water react in the presence of a catalyst to form hydrogen, carbon dioxide and minor reaction products. The reformer tubes are each a concentric tube or double-pipe welded assembly with the methanol decomposition catalyst packed within the annular space between the inner and outer pipes. The hot flue gas from the feed vaporizer combustion chamber enters the bottom of the vertically arranged inner pipe at approximately 1600°F. and heat is transferred through the inner pipe wall to the catalyst particles in the annular space. The ratio of heat transfer surface to catalyst quantity shall be provided so that sufficient heat is transferred to supply the endothermic heat of reaction and also

V. PLANT DESIGN - contd.

to maintain the temperature of the reactants and products at the required temperature level, approximately 700°F. A bellows type expansion joint, suitable for the temperature and pressure service conditions is installed between the ends of the outer pipe to accommodate to the difference in expansion between the inner pipe at 1600°F. and the outer pipe at 700°F.

The reacting methanol and water vapor flow downward over the catalyst particles which are supported by a stainless steel screen at the bottom of the bed. The screen is held by a rugged grid which is welded to the inner pipe. The reaction products pass from the annular space below the catalyst support through eight radial pipe elbows welded to the outer pipe.

The flue gas effluent from the methanol feed preheater passes to the shell side of a shell and tube exchanger type cooler. The gas is cooled to about 200°F. by heat exchange with the circulating cooling water and most of the water vapor is condensed. The mixture of gas and condensate flows to a separator. The separator is a vertical cylindrical pressure vessel with nozzle connections for gas inlet, outlet, water drain and level control. The cooled carbon dioxide together with a small amount of uncondensed water vapor flows from the top of the vessel to disposal. The condensed water separated from the gas stream flows from the bottom of the separator to the suction of the process condensate feed pump and of the fuel water injection pump. Make-up water needed to maintain a level in the separator is added to the gas stream entering the flue gas cooler and is regulated by a level control switch.

The hydrogen purification system consists essentially of a group of palladium-silver alloy diffusion tubes arranged in parallel flow for receiving the crude hydrogen from the reformer tubes. The purified hydrogen effluent from the palladium diffusion tubes contains virtually no contaminants and is of sufficiently high purity for use in hydrogen-oxygen fuel cells. The carbon dioxide, water vapor, and minor amounts of carbon monoxide, methane and unreacted methanol, together with a small fraction of the crude hydrogen produced pass from the diffusion tubes as purge gas. The purge gas is utilized for its heating value in the feed vaporizer burner.

The palladium alloy diffusion tubes used in the purification are the J. Bishop and Company Model A-71, modified slightly

V. PLANT DESIGN - contd.

at the end connections. Each A-71 cell consists of a large number of palladium alloy tubes 1/16" O.D. with a 3 mil (0.003 inch) wall closed at one end. These thin-walled tubes are contained within a heavy-walled stainless steel shell 1.36" O.D. by 27-3/4" long. They are all manifolded together within the cell so that the purified hydrogen output of all the small tubes is combined and passes from the cell in a common exit line. There are 8 A-71 cells for each of the 8 reformer tube units, or a total of 64 cells. The end modifications consist of substituting welded end connections for the Parker flared fittings standard on the Bishop A-71 cell design.

The advantage of welding the connections to the palladium tube cells is the improvement in strength and compactness of the multiple cell assembly.

In order to protect the fuel cells from the deleterious effect of carbon monoxide in case of diffusion tube leakage a methanator guard chamber is provided. The methanator is a vertical cylindrical pressure vessel containing methanation catalyst supported on a screen held on transverse bars near the bottom of the vessel. All of the metal parts of the methanator are stainless steel. The hot purified hydrogen from the diffusion tubes enters the top of the methanation catalyst and flows downward through the bed.

The pure hydrogen effluent from the methanator flows to the lower part of a direct contact cooler-saturator. The saturator is a vertical cylindrical pressure vessel in which a water level is maintained at a set range of elevation above the bottom of the vessel. Vessel connection nozzles are provided for gas inlet and outlet, water inlet, drain, and level control.

V. PLANT DESIGN - contd.

B. Detailed Process Calculations

1. Material and Heat Balance

In this section are contained the detailed process calculations for the material and heat balance for the hydrogen generation system. The calculations are based on one mol of methanol for feed. From these basic calculations the material and energy requirements for the various production rates are calculated by using the appropriate scale-up factors.

Hydrogen Generation Capacity

| | | |
|--------------|-----------|-------------|
| Maximum rate | 70 lbs/hr | 35 mols/hr |
| Normal rate | 20 lbs/hr | 10 mols/hr |
| Minimum rate | 5 lbs/hr | 2.5 mols/hr |

Hydrogen Purity and Delivery Conditions

| | |
|-----------------|-----------------------|
| Hydrogen purity | essentially 100% |
| Pressure | 1 - 3 psig |
| Temperature | 140°F |
| Water vapor | essentially saturated |

Raw Materials and Utilities Available

| | |
|---|------------------------------------|
| Methanol | See specification in Section III-D |
| Steam Condensate or demineralized water | at 10 psig (min) |
| Cooling water | at 95°F and 50 psig |
| Electrical power | AC or DC |

Basis for Process Calculations - 1 mol CH₃OH feed

Reformer Operating Conditions

The operating conditions picked for this application are those that best integrate into the overall design without deviating too far from conditions that have been previously tested. However, the overall combination of conditions should be confirmed by actual operation. Past operation has covered the following ranges:

| | |
|---------------------|--------------|
| Pressure | 0 - 300 psig |
| Temperature | 500 - 700°F |
| Steam to gas ratio | 1:1 to 4:1 |
| Residual methane | 0.5 - 0.8% |
| Methanol conversion | 98 - 100% |

The operating conditions for this application are taken to be the following:

| | |
|--------------------|---|
| Pressure | 425 psig |
| Temperature | 700°F |
| Steam to gas ratio | 2:1 |
| Residual methane | 1.0% v (of hydrogen only) |
| Residual methanol | 100°F approach to equilibrium valve ($K_p = 2.32 \times 10^5$ at 600°F) |
| Carbon Monoxide | 100°F approach to equilibrium valve ($K_{III} = 9.03$ at 800°F) |

Reformer Exit Gas Composition

Residual Methanol

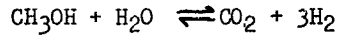

$$K_p = \frac{(\text{CO}_2) (\text{H}_2)^3}{(\text{H}_2\text{O}) (\text{CH}_3\text{OH})} \left(\frac{P}{\sum N} \right)^2 = 2.32 \times 10^5 \text{ at } 600^\circ\text{F}$$

Let x = methanol reacted

$$\begin{array}{r} \text{CH}_3\text{OH} \quad 1-x \\ \text{H}_2\text{O} \quad 2-x \\ \text{CO}_2 \quad x \\ \text{H}_2 \quad 3x \\ \hline 3+2x \end{array}$$

Let x = 0.996

$$K_p = \frac{(0.996) (2.988)^3}{(0.004) (1.004)} \left(\frac{30}{4.992} \right)^2 = 2.39 \times 10^5$$

Thus, residual $\text{CH}_3\text{OH} = 0.004$ mols/mol CH_3OH feed

The overall reforming reaction can be expressed as follows:

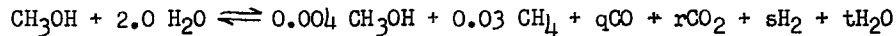

where q = final mols of CO per mol of CH_3OH feed

$$\begin{array}{r} r = \text{ " " " CO}_2 \text{ " " " " " " } \\ s = \text{ " " " H}_2 \text{ " " " " " " } \\ t = \text{ " " " H}_2\text{O} \text{ " " " " " " } \end{array}$$

$$\begin{array}{l} \text{By overall carbon balance } 1 = 0.004 + 0.030 + q + r \\ r = 0.966 - q \end{array}$$

$$\begin{array}{l} \text{By overall oxygen balance } 1 + 2 = 0.004 + q + 2r + t \\ 2.996 = q + 2(0.996 - q) + t \\ t = 1.064 + q \end{array}$$

$$\begin{array}{l} \text{By overall hydrogen balance } 2 + 2 = 0.008 + 0.060 + s + t \\ 3.932 = s + 1.064 + q \\ s = 2.868 - q \end{array}$$

Gas composition is computed from water gas shift at 800°F

$$K_{III} = \frac{\text{CO}_2 \times \text{H}_2}{\text{CO} \times \text{H}_2\text{O}} = \frac{(0.996 - q)(2.868 - q)}{(q)(1.064 + q)} = 9.03 \text{ at } 800^\circ\text{F}$$

Let q = 0.185

$$K_{III} = \frac{(0.781)(2.683)}{(0.185)(1.249)} = 9.07$$

The exit gas composition from the methanol reformer is:

| | | | |
|--------------------|--------------|----------|----------------------------|
| CO | 0.185 | Mols/mol | of CH ₃ OH feed |
| CO ₂ | 0.781 | " | " |
| H ₂ | 2.683 | " | " |
| H ₂ O | 1.249 | " | " |
| CH ₃ OH | 0.004 | " | " |
| CH ₄ | <u>0.030</u> | " | " |
| | 4.932 | " | " |

Reformer Duty

Absolute enthalpy of reactants preheated to 700°F

| | | | | | | | |
|--------------------|-------|---|---------|---|-----------------|---------|----------------------------|
| CH ₃ OH | 1.000 | x | -68,258 | = | -68,258 | Btu/mol | of CH ₃ OH feed |
| H ₂ O | 2.000 | x | -93,303 | = | <u>-186,606</u> | " | " |
| | | | | | -254,864 | " | " |

Absolute enthalpy of products at 700°F

| | | | | | | | |
|--------------------|--------------|---|----------|---|-------------|---------|----------------------------|
| CO | 0.185 | x | -40,803 | = | -7,549 | Btu/mol | of CH ₃ OH feed |
| CO ₂ | 0.781 | x | -158,651 | = | -123,906 | " | " |
| H ₂ | 2.683 | x | 7,991 | = | -21,440 | " | " |
| H ₂ O | 1.249 | x | -93,303 | = | -116,535 | " | " |
| CH ₃ OH | 0.004 | x | -68,258 | = | -273 | " | " |
| CH ₄ | <u>0.030</u> | x | -17,765 | = | <u>-533</u> | " | " |
| | 4.932 | | | | -227,356 | | |

Reformer duty = (-227,356) - (-254,864) = +27,508 Btu/mol of CH₃OH feed

Aqueous Methanol Feed Preheater Duty

Preheat reformer feed to 350°F

Methanol in storage at 60°F

Condensate recycled from flue gas cooler at 200°F

| | | | | | | | |
|--------------------|--------|---|-----------------|---|--------------|---------|----------------------------|
| CH ₃ OH | 32 lbs | x | (232.9 - 16.0) | = | 6,940 | Btu/mol | of CH ₃ OH feed |
| H ₂ O | 36 lbs | x | (321.6 - 168.0) | = | <u>5,530</u> | " | " |
| | | | | | 12,470 | " | " |

Aqueous Methanol Feed Vaporizer Duty

Preheat, vaporize and superheat reformer feed to 700°F

The boiling point is approximately 420°F

Preheat duty

CH₃OH 32 lbs x (291.0 - 232.9) = 1,860 Btu/mol CH₃OH feed
 H₂O 36 lbs x (396.8 - 321.6) = 2,710 "
 4,570 "

Vaporizing duty

CH₃OH 32 lbs x (513.0 - 291.0) = 7,100 Btu/mol CH₃OH feed
 H₂O 36 lbs x (1203.1 - 396.8) = 29,030 "
 36,130 "

Superheating duty

CH₃OH 32 lbs x (647.8 - 513.0) = 4,310 Btu/mol of CH₃OH feed
 H₂O 36 lbs x (1368.3 - 1203.1) = 5,950 "
 10,260 "

Reformer feed vaporizer duty = 50,960 Btu/mol of CH₃OH feed

Purge Gas Combustion

The palladium-silver alloy hydrogen diffusion cells are to be sized to recover 92% of the hydrogen in the reformer exit gas. The purge gas from the diffusion cell and the oxygen required for combustion are:

| | Purge Gas | + | Oxygen | | CO ₂ | + | H ₂ O |
|--------------------|--------------|---|---------------|---|-----------------|---|------------------|
| CO | 0.185 | + | 0.0925 | → | 0.185 | | |
| CO ₂ | 0.781 | + | | → | 0.781 | | |
| H ₂ | 0.215 | + | 0.1075 | → | | | 0.215 |
| H ₂ O | 1.249 | + | | → | | | 1.249 |
| CH ₃ OH | 0.004 | + | 0.0060 | → | 0.004 | + | 0.008 |
| CH ₄ | <u>0.030</u> | + | <u>0.0600</u> | → | <u>0.030</u> | + | <u>0.060</u> |
| | 2.464 | | 0.2660 | | 1.000 | | 1.532 |

Heat recovered when burning this gas at 700°F and cooling flue gas to 800°F Oxygen taken at 60°F

Absolute enthalpy of reactants

Purge Gas at 700°F

| | | | | | | |
|--------------------|-------|---|----------|---|----------|------------------------------------|
| CO | 0.185 | x | - 40,803 | = | - 7,549 | Btu/mol of CH ₃ OH feed |
| CO ₂ | 0.781 | x | -158,651 | = | -123,906 | " |
| H ₂ | 0.215 | x | 7,991 | = | 1,718 | " |
| H ₂ O | 1.249 | x | - 93,303 | = | -116,535 | " |
| CH ₃ OH | 0.004 | x | - 68,258 | = | - 273 | " |
| CH ₄ | 0.030 | x | - 17,765 | = | - 533 | " |
| | 2.464 | | | | -247,078 | " |

Oxygen at 60°F

| | | | | | | |
|----------------|-------|---|-------|---|----------|---|
| O ₂ | 0.266 | x | 3,607 | = | 959 | " |
| | | | | | -246,119 | " |

Absolute enthalpy of products at 800°F

| | | | | | | |
|------------------|-------|---|----------|---|----------|---|
| CO ₂ | 1.000 | x | -157,480 | = | -157,480 | " |
| H ₂ O | 1.532 | x | - 92,407 | = | -141,568 | " |
| | 2.532 | | | | -299,048 | " |

Heat recoverable from burning purge gas with oxygen = (-299,048) - (-246,119) = -52,929 Btu/mol of CH₃OH feed

Methanol Water Combustion

| | | |
|-------------------------------------|-----------------|------------------------------------|
| Heat release required for reforming | = 27,508 | Btu/mol of CH ₃ OH feed |
| " vaporizer | = 50,960 | " |
| " heat loss | = <u>4,286</u> | " |
| | 82,754 | " |
| Heat recoverable from purge gas | = <u>52,929</u> | " |
| Heat required from burning methanol | = 29,825 | " |

Since the response to preheating and vaporizing aqueous methanol from its own flue gas would be slow, burn the liquid mixture with oxygen.

Check flame temperature of 4.5 to 1.0 mol ratio of water to methanol.

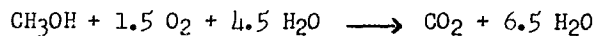

Absolute enthalpy of reactants

| | | | |
|----------------------------|----------------------------------|--------------------------------------|---|
| CH ₃ OH at 60°F | 1.0 x -93,404 = -93,404 | Btu/mol of CH ₃ OH burned | " |
| O ₂ at 60°F | 1.5 x 3,607 = 5,411 | | " |
| H ₂ O at 200°F | <u>4.5 x -115,155 = -518,198</u> | | " |
| | 7.0 | -606,191 | " |

Absolute enthalpy of products at 2700°F

| | | |
|------------------|---------------------------------|---|
| CO ₂ | 1.0 x -131,980 = -131,980 | " |
| H ₂ O | 6.5 x -72,680 = <u>-472,420</u> | " |
| | -604,400 | " |

Adiabatic flame temperature is slightly above 2700°F

Absolute enthalpy of products at 800°F

| | | |
|------------------|---------------------------------|---|
| CO ₂ | 1.0 x -157,480 = -157,480 | " |
| H ₂ O | 6.5 x -92,407 = <u>-600,646</u> | " |
| | -758,126 | " |

Heat recovered from burning one mol of methanol and cooling flue gas to 800°F = (-758,126) - (-606,191) = 151,935 Btu/mol of CH₃OH burned

$$\text{Mols methanol burned per mol of methanol feed} = \frac{29,825}{151,935} = 0.196$$

Heat Recovery from Combined Flue Gases

Absolute enthalpy of reactants

| | | |
|---|---|--|
| 2.464 purge gas + 0.266 O ₂ | → | 1.000 CO ₂ + 1.532 H ₂ O |
| 0.196 CH ₃ OH + <u>0.294</u> O ₂ + 0.882 H ₂ O | → | <u>0.196</u> CO ₂ + <u>1.274</u> H ₂ O |
| 0.560 | | 1.196 CO ₂ + 2.806 H ₂ O |

| | | |
|-----------------------|-------------------|------------------------------------|
| Purge gas | = -246,119 | Btu/mol of CH ₃ OH feed |
| Methanol feed mixture | = <u>-118,813</u> | " |
| | -364,932 | " |

Absolute enthalpy of products at 2600°F

| | | |
|------------------|-----------------------------------|---------------------------------|
| CO ₂ | 1.196 x -133,420 = -159,570 | Btu/mol CH ₃ OH feed |
| H ₂ O | <u>2.806 x -73,800 = -207,082</u> | " |
| | 4.002 | -366,652 |

Also at 1600°F

$$\begin{array}{rcl} \text{CO}_2 & 1.196 \times -147,317 & = -176,191 \text{ Btu/mol CH}_3\text{OH feed} \\ \text{H}_2\text{O} & 2.806 \times -84,691 & = \underline{-237,643} \quad " \\ & & -413,834 \end{array}$$

Also at 800°F

$$\begin{array}{rcl} \text{CO}_2 & 1.196 \times -157,480 & = -188,346 \quad " \\ \text{H}_2\text{O} & 2.806 \times -92,407 & = \underline{-259,294} \quad " \\ & & -447,640 \quad " \end{array}$$

Also at 400°F

$$\begin{array}{rcl} \text{CO}_2 & 1.196 \times -161,968 & = -193,714 \quad " \\ \text{H}_2\text{O} & 2.806 \times -95,885 & = \underline{-269,053} \quad " \\ & & -462,767 \quad " \end{array}$$

Also at 300°F

$$\begin{array}{rcl} \text{CO}_2 & 1.196 \times -162,997 & = -194,944 \quad " \\ \text{H}_2\text{O} & 2.806 \times -96,717 & = -271,388 \quad " \\ \text{H}_2\text{O}(\ell) & 2.525 \times -16,382 & = \underline{-41,365} \quad " \\ & & -507,697 \quad " \end{array}$$

Uncondensed water vapor at 300°F and 350 psig

$$\text{H}_2\text{O} = 1.196 \times \frac{67.0}{364.7 - 67.0} \times \frac{1}{0.957} = 0.281 \text{ mols}$$

Uncondensed water vapor at 200°F and 350 psig

$$\text{H}_2\text{O} = 1.196 \times \frac{11.5}{364.7 - 11.5} \times \frac{1}{0.99} = 0.039 \text{ mols}$$

Heat removal to cool products from 300°F to 200°F

$$\begin{array}{rcl} \text{CO}_2 & 1.196 \times 9.3 \times (300 - 200) & = 1,112 \text{ Btu/mol CH}_3\text{OH feed} \\ \text{H}_2\text{O} & 0.281 \times 8.1 \times (300 - 200) & = 228 \quad " \\ \text{H}_2\text{O}(\ell) & 0.242 \times 17,602 & = 4,260 \quad " \\ \text{H}_2\text{O} & 2.525 \times 18 \times (300 - 200) & = \underline{4,545} \quad " \\ & & 10,145 \quad " \end{array}$$

Temperature-Heat recovered from flue gas

| | | | |
|------|---------|------------------------------------|-------------|
| 2640 | 0 | Adiabatic flame temperature | |
| 2600 | 1,983 | Btu/mol of CH ₃ OH feed | |
| 1600 | 49,165 | " | |
| 800 | 82,971 | " | |
| 400 | 98,098 | " | (Dew Point) |
| 300 | 143,028 | " | |
| 200 | 153,173 | " | |

Palladium Silver Alloy Hydrogen Diffusion Cell

$$\text{Inlet H}_2 \text{ concentration} = \frac{2.683}{4.932} \times 100 = 54.4\%$$

$$\text{Hydrogen recovered} = 2.683 \times 0.92 = 2.468 \text{ mol/mol of CH}_3\text{OH feed}$$

$$\text{Hydrogen concentration in purge gas} = \frac{2.683 - 2.468}{4.932 - 2.468} \times 100 = 8.7\%$$

$$\text{Average H}_2 \text{ concentration in feed} = 31.5\%$$

Direct Contact Cooler Saturation

Hydrogen feed = 2.468 mols/mol of CH₃OH feed

Inlet temperature = 700°F

Exit temperature = 140°F

Condensate from hydrogen-oxygen fuel cell at 140°F

$$\text{Condensate vaporized} = \frac{2.468 \times (7991 - 4079)}{18 \times 1014.1} = 0.529 \text{ mols/mol of CH}_3\text{OH feed}$$

Hydrogen is saturated at 140°F and 1.5 psig

$$\% \text{ saturated at 0 psig} = \frac{0.529}{2.997} \times \frac{14.7}{2.89} \times 100 = 90\%$$

Temperature at which H₂ is saturated at 0 psig = 136°F

Flue Gas Cooler Duty

$$153,173 - 12,470 - 82,754 = 57,949 \text{ Btu/mol CH}_3\text{OH feed}$$

Water Balance

| | | |
|---------------------------|-------|-------------------------------------|
| Water in reformer feed | 2.000 | mols/mol of CH ₃ OH feed |
| Water in reformer fuel | 0.882 | " |
| Water to saturate product | 0.529 | " |
| | 3.411 | " |

| | | |
|-------------------------------------|--------------|-------------------------------------|
| Water condensed in cooler | 2.767 | mols/mol of CH ₃ OH feed |
| Water out in product H ₂ | <u>0.529</u> | " |
| | 3.296 | " |
| Water make-up | 0.115 | " |

Oxygen Vaporizer Duty

| | |
|---|-------------|
| Oxygen flow = 0.560 mols/mol of CH ₃ OH feed | |
| Inlet temperature and enthalpy = -297.6°F | 290 Btu/mol |
| Liquid at boiling point (465 psig) = -202°F | 1640 " |
| Vapor at " " " " = -202°F | 3250 " |
| Outlet temperature = 60°F | 5630 " |

Oxygen vaporizer duty = 0.560 (5630 - 290) = 2990 Btu/mol CH₃OH feed

Scale-up Factor

Hydrogen produced per mol methanol feed = 2.468 mols
 Maximum hydrogen rate = 35.0 mols/hr

Scale-up factor = $\frac{35.00}{2.468} = 14.1815$

Material Balance at Maximum Production Rate (Pound Mols/Hr)

| | 1 Methanol Feed | 2 Water Feed | 3 Reformer Effluent | 4 Dry Hydrogen | 5 Purge Gas | 6 Oxygen |
|--------------------|-----------------------|--------------------|---------------------------|---------------------------|----------------------------|-------------|
| CO | | | 2.62 | | 2.62 | |
| CO ₂ | | | 11.08 | | 11.08 | |
| H ₂ | | | 38.05 | 35.00 | 3.05 | |
| H ₂ O | | 28.36 | 17.71 | | 17.71 | |
| CH ₃ OH | 14.18 | | 0.06 | | 0.06 | |
| CH ₄ | | | 0.43 | | 0.43 | |
| O ₂ | | | | | | 7.94 |
| Total | <u>14.18</u> | <u>28.36</u> | <u>69.95</u> | <u>35.00</u> | <u>34.95</u> | <u>7.94</u> |
| Pres, psig | 450 | 450 | 425 | 15 | 415 | 450 |
| Temp. °F | 60 | 200 | 700 | 700 | 700 | 60 |
| gpm | 1.15 | 1.02 | | | | |
| | 7 Fuel | 8 Flue Gas | 9 Condensate | 10 Product Hydrogen | 11 Condensate Makeup | |
| CO ₂ | | 16.96 | | | | |
| H ₂ | | | | 35.00 | | |
| H ₂ O | 12.51 | 39.79 | 7.50 | 7.50 | 1.63 | |
| CH ₃ OH | <u>2.78</u> | | | | | |
| Total | <u>15.29</u> | <u>56.75</u> | <u>7.50</u> | <u>42.50</u> | <u>1.63</u> | |
| Pres, psig | 450 | 360 | 10 | 1-2 | 360 | |
| Temp. °F | | 800 | 140 | 140 | 140 | |
| gpm | | | 0.27 | | 0.06 | |

Heat Transfer Duties

| | | | |
|---------------------------------|---|---------|--------|
| Aqueous Methanol Feed Preheater | = | 176,800 | Btu/hr |
| Aqueous Methanol Feed Vaporizer | = | 722,700 | " |
| Reformer | = | 390,100 | " |
| Flue Gas Cooler | = | 821,700 | " |
| Oxygen Vaporizer | = | 42,400 | " |

Electrical Power Requirements

1A Process Methanol Feed Pump
$$\text{BHP} = \frac{1.15 \times 450}{1714 \times 0.75} = 0.41 \quad (\text{kw} = 0.41 \times \frac{0.746}{0.80} = 0.38)$$

1B Process Condensate Feed Pump
$$\text{BHP} = \frac{1.02 \times 450}{1714 \times 0.75} = 0.36 \quad (\text{kw} = 0.34)$$

2A Fuel Methanol Feed Pump
$$\text{BHP} = \frac{0.23 \times 450}{1714 \times 0.75} = 0.08 \quad (\text{kw} = 0.08)$$

2B Fuel Water Injection Pump
$$\text{BHP} = \frac{0.45 \times 450}{1714 \times 0.75} = 0.16 \quad (\text{kw} = 0.15)$$

3 Condensate Makeup Pump
$$\text{BHP} = \frac{0.06 \times 360}{1714 \times 0.50} = 0.03 \quad (\text{kw} = 0.03)$$

4 Oxygen Pump
$$\text{BHP} = \frac{0.45 \times 450}{1714 \times 0.50} = 0.24 \quad (\text{kw} = 0.24)$$

Power requirements at maximum rate = 1.22 kw

Raw Material and Utility Usage at Normal Rate

| | | | |
|-------------------------------------|---|---------------------------|-------------------------------|
| Hydrogen production | = | 20 lbs/hr | 10 mols/hr |
| Mols/hr of CH ₃ OH feed | = | $\frac{10}{2.468}$ | = 4.052 mols/hr |
| Heat required for vaporization | = | 4.052 x 50,960 | = 206,490 Btu/hr |
| " " " reforming | = | 4.052 x 27,508 | = 111,462 " |
| Heat loss above 800°F | = | 14.18 x 4,268 | = $\frac{60,775}{378,727}$ " |
| Heat recovered above 800°F in purge | = | 4.052 x 52,929 | = $\frac{214,468}{164,259}$ " |
| Heat provided by burning methanol | = | | |
| Mols/hr of CH ₃ OH fuel | = | $\frac{164,259}{151,935}$ | = 1.081 mols/hr |

Oxygen to burn purge gas = $4.052 \times 0.266 = 1.078$ mols/hr
 " " " CH₃OH fuel = $1.081 \times 1.500 = \frac{1.622}{2.700}$ "

Cooling duty in flue gas cooler

Heat to be removed below 800°F per mol of methanol feed. Absolute enthalpy at 200°F

| | | | | | |
|--------------------|---------|----------|---|----------|---------------------------------|
| CO ₂ | 1.000 x | -163,978 | = | -163,978 | Btu/mol CH ₃ OH feed |
| H ₂ O | 1.532 x | -97,537 | = | -149,427 | " |
| H ₂ O() | 1.498 x | -17,602 | = | -26,368 | " |
| | | | | -339,773 | " |
| | | | | -299,048 | " |
| | | | | -40,725 | " |

Heat to be removed below 800°F per mol of methanol fuel
 Absolute enthalpy at 200°F

| | | | | | |
|--------------------|--------|----------|---|----------|---------------------------------|
| CO ₂ | 1.00 x | -163,978 | = | -163,978 | Btu/mol CH ₃ OH fuel |
| H ₂ O | 6.50 x | -97,537 | = | -633,991 | " |
| H ₂ O() | 6.47 x | -17,602 | = | -113,885 | " |
| | | | | -911,854 | " |
| | | | | -758,126 | " |
| | | | | -153,728 | " |

Flue gas cooler duty

$4.052 \times 40,725 = 165,018$ Btu/hr
 $1.081 \times 153,728 = \frac{166,180}{331,198}$ Btu/hr

Heat removed in pre-

heater $\frac{50,528}{331,198}$ Btu/hr

Flue gas cooler duty = $280,670$ Btu/hr (28 gpm)

Raw Material and Utility Usage at Minimum Rate

Hydrogen production = 5 lbs/hr 2.5 mols/hr
 Mols/hr of CH₃OH feed = $\frac{2,500}{2.468} = 1.013$ mols/hr

Heat required for vaporization = $1.013 \times 50,960 = 51,622$ Btu/hr
 " " " reforming = $1.013 \times 27,508 = 27,866$ "
 Heat loss above 800°F = $14.18 \times 4268 = \frac{60,775}{140,263}$ "

Heat recovered above 800°F in purge = $1.013 \times 52,929 = \frac{53,617}{86,646}$ "
 Heat provided by burning methanol = $86,646$ "
 Mols/hr of CH₃OH fuel = $\frac{86,646}{151,935} = 0.570$ mols/hr

Oxygen to burn purge gas = $1.013 \times 0.266 = 0.269$
 " " " CH₃OH fuel = $0.570 \times 1.500 = \frac{0.855}{1.124}$ mols/hr

$$\begin{aligned} \text{Flue gas cooler duty} \\ 1.013 \times 40,725 &= 41,254 \text{ Btu/hr} \\ 0.570 \times 153,728 &= \frac{87,625}{128,879} \text{ "} \end{aligned}$$

$$\begin{aligned} \text{Heat removed in pre-} \\ \text{heater} &= \frac{12,632}{116,247} \text{ "} \\ \text{Flue gas cooler duty} &= 116,247 \text{ " (12 gpm)} \end{aligned}$$

Cold Gas Efficiency at Maximum Rate

$$\text{Efficiency} = \frac{35 \times 122,970}{16.96 \times 312,570} \times 100 = 81.2\%$$

Volume of Hydrogen in System

1. In Reformer

$$\begin{aligned} \text{Cross sectional area} &= \frac{(12.73 - 4.43)}{144} = 0.0576 \text{ ft}^3 \\ \text{Volume in 8 tubes} &= 0.0576 \times 8 \times 11.42 = 5.27 \text{ ft}^3 \\ \text{Catalyst voids} &= 50\% \\ \text{Max H}_2 \text{ Concentration} &= 54.4\% \\ \text{Temperature} &= 700^\circ\text{F} \\ \text{Pressure} &= 30 \text{ atm} \\ \text{H}_2 &= 5.27 \times 30 \times 0.5 \times \frac{0.544 \times 520}{1160} = 19.3 \text{ SCF} \end{aligned}$$

2. In Palladium Diffusion Cell

$$\begin{aligned} \text{Volume per cell} &= \frac{1.496}{144} \times \frac{28}{12} = 0.0243 \text{ ft}^3 \\ \text{Number of cells} &= 64 \\ \text{Average H}_2 \text{ Concentration} &= 31.5\% \\ \text{Temperature} &= 700^\circ\text{F} \\ \text{Pressure} &= 30 \text{ atm} \\ \text{H}_2 &= 0.0243 \times 64 \times 30 \times \frac{0.315 \times 520}{1160} = 6.6 \text{ SCF} \end{aligned}$$

3. In Methanator

$$\begin{aligned} \text{Cross sectional area} &= \frac{240.5}{144} = 1.67 \text{ ft}^2 \\ \text{Catalyst voids} &= 40\% \\ \text{Temperature} &= 700^\circ\text{F} \\ \text{Pressure} &= 1.2 \text{ atm} \\ \text{H}_2 &= 1.67 \times 1.2 \times \frac{520}{1160} \times (1.083 \div 0.4 \times 2.75) = 2.0 \text{ SCF} \end{aligned}$$

4. Saturator

$$H_2 = \frac{120.6}{144} \times (4.5 \times 0.5) \times \frac{520}{600} \times 1.2 = 2.0 \text{ SCF}$$

5. Piping

Assume 150' of 1/2" pipe

$$H_2 = 150 \times \frac{0.304}{144} \times \frac{520}{1160} \times 30 \times 0.544 = 2.3 \text{ SCF}$$

6. Total holdup of Hydrogen = 32.2 SCF

V. PLANT DESIGN - contd.

2. Utility Requirements

The utility and raw material requirements are calculated as shown above. The results are summarized in Table V-1.

Figure V-B-2 shows graphically the effect of hydrogen production rate on the raw material consumption. The hydrogen production rate is expressed as pounds per hour while the methanol and oxygen consumption is expressed as pounds per pound of hydrogen produced. These curves increase greatly as the hydrogen production decreases because of the proportionally increased effect of heat loss at the lower rates. Also included in Figure V-B-2 is the cold gas efficiency, the heating value in the product as a percentage of the heating value in the total methanol.

TABLE V-1

Summary of Raw Materials and Utilities at Various Rates

| <u>Rate</u> | <u>Minimum</u> | <u>Normal</u> | <u>Maximum</u> |
|----------------------------------|----------------|---------------|----------------|
| Product H ₂ , Lbs/Hr. | 5 | 20 | 70 |
| Methanol | | | |
| To Process, Lbs/Hr. | 32.4 | 129.7 | 453.8 |
| To Fuel Lbs/Hr. | <u>18.2</u> | <u>34.6</u> | <u>89.0</u> |
| Total Lbs/Hr. | 50.6 | 164.3 | 542.8 |
| Oxygen, Lbs/Hr. | 36.0 | 86.4 | 254 |
| Condensate, Lbs/Hr. | 12 | 47 | 165 |
| Cooling Water, GPM | 12 | 28 | 82 |
| Electrical Power, KW | 1.22 | 1.22 | 1.22 |
| Cold Gas Efficiency, % | 62.1 | 76.6 | 81.2 |

V. PLANT DESIGN - contd.

3. Equipment Sizing

The detailed calculations on the sizing of the equipment are summarized in this section. Included is an equipment list giving the major design specifications on the pieces of equipment used in the proposed system.

Equipment Sizing (Other than Pumps)

a. Aqueous Methanol Feed Preheater

Duty = 176,800 Btu/hr.

Liquid in = 150°F; Liquid Out = 350°F.

Flue gas in 800°F; Flue gas Out = 475°F.

LM $\Delta T = \frac{450 - 325}{1} = 383^\circ\text{F}.$

$$\ln \frac{450}{325}$$

$$\text{Surface area} = \frac{176,800}{383 \times 30} = 15.4 \text{ ft.}^2$$

b. Aqueous Methanol Feed Vaporizer

Duty = 722,700 Btu/hr.

Heat flux = 20,000 Btu/hr/ft.²

$$\text{Surface area} = \frac{722,700}{20,000} = 36.1 \text{ ft.}^2$$

c. Reformer

Duty = 390,100 Btu/hr.

Process gas in = 700°F., Out 700°F.

Flue gas in = 1490°F., Out 800°F.

Space velocity = 3000 SCFH of H₂/vol of catalyst

LM $\Delta T = \frac{790 - 100}{1} = 334^\circ\text{F}.$

$$\ln \frac{790}{100}$$

$$\text{Catalyst volume} = \frac{38.05 \times 379.5}{3000} = 4.81 \text{ ft.}^3$$

$$\text{Surface area} = \frac{390,100}{334 \times 22.5} = 52 \text{ ft.}^2$$

Flow area inside 4" Sch. 40 pipe = 0.0884 ft.²

Total area of 2" pipe = 0.0308 ft.²

Annular flow area = 0.0576 ft.²

$$\text{Length of annulus} = \frac{4.81}{0.0576} = 83.5 \text{ ft. (eight 10'-6" lengths)}$$

$$\text{Surface} = 0.622 \times 84 = 52.2 \text{ ft.}^2$$

V. PLANT DESIGN - contd.

d. Flue Gas Cooler

Duty = 821,700 Btu/hr.
 Cooling water In 95°F.; Out 115°F. Flow = 82.1 GPM
 Flue gas in 475; Out 200°F.
 LMTD = $\frac{360 - 105}{\ln \frac{360}{105}}$ = 207°F.

$$\text{Surface area} = \frac{821,700}{207 \times 100} = 39.7 \text{ ft.}^2$$

e. Oxygen Vaporizer

Duty = 42,400 Btu/hr.
 Oxygen In -297°F.; Out 60°F.
 Cooling water In 115°F.; Out 114°F.
 LMTD = $\frac{410 - 55}{\ln \frac{410}{55}}$ = 177°F.

$$\text{Surface area} = \frac{42,400}{177 \times 80} = 3.0 \text{ ft.}^2$$

f. Palladium Hydrogen Diffusion Cell

Flow = 35 x 379.5 = 13,300 SCF/Hr.
 Capacity of J. Bishop Type A-71 cell for pure H₂
 at 400 psig differential pressure = 650 SCF/Hr.
 Correction factor for operation at average H₂
 concentration of 31.5% = 0.35
 Correction factor for having product hydrogen
 pressure greater than 0.95
 Capacity per cell = 650 x 0.35 x 0.95 = 216 SCF/Hr.

$$\text{Number of A-71 cells} = \frac{13,300}{216} = 61.6$$

g. Methanator

Flow = 13,300 SCF/hr.
 Space velocity = 3000 SCF/hr. of H₂/ft.³ of catalyst
 Catalyst volume = $\frac{13,300}{3,000}$ = 4.43 ft.³

Bed dimensions = 18" sch. ST pipe x 2'-9" high

h. Saturator

Flow = 42.5 x 379.5 = 16,100 SCF/Hr. 5.2 ACF/Sec.
 Molecular weight = 4.83
 Allowable superficial velocity = 0.1 x $\sqrt{\frac{62.3}{0.011}}$ = 7.9 ft./sec.

$$\text{Cross sectional area} = \frac{5.2}{7.9} = 0.66 \text{ ft.}^2$$

V. PLANT DESIGN - contd.

Use 12" sch. 20 pipe x 4'-0" TT

i. Separator

Flow = $17.54 \times 379.5 = 6660$ SCF/Hr. 0.095 ACF/Sec.

Molecular weight = 44

Allowable superficial velocity = $0.1 \times \sqrt{\frac{62.3 - 2.3}{2.3}} = 0.51$ ft/sec.

Cross sectional area = $\frac{0.095}{0.51} = 0.186$ ft.² (6" Sch. 40 pipe)

Size for 2 min. holdup of condensate,

Volume = $2 \times 1.47 = 2.94$ gal. or 24.5 lbs.

Use 8" Sch. 40 pipe x 3'-0" TT

Equipment List

a. Process Methanol Feed Pump

| | |
|---------------|-----------------|
| Type | Reciprocating |
| Capacity | 1.21 GPM (max.) |
| Suction Pres. | 0 to 320 Psig. |
| Disc Pres. | 450 Psig. |
| Suction Temp. | 30 - 85°F. |

Process Condensate Feed Pump

| | |
|---------------|-----------------|
| Type | Reciprocating |
| Capacity | 1.07 GPM (max.) |
| Suction Pres. | 0 - 350 Psig. |
| Disc Pres. | 450 Psig. |
| Suction Temp. | 100 to 200°F. |

Use 1.5 H.P. electric motor drive with speed control turn down of 20 to 1.0. Duplex pump with methanol in one cylinder and condensate in the other cylinder.

b. Fuel Methanol Feed Pump

| | |
|---------------|-----------------|
| Type | Reciprocating |
| Capacity | 0.24 GPM (max.) |
| Suction Pres. | 0 to 320 Psig. |
| Disc Pres. | 450 Psig. |
| Suction Temp. | 30 - 85°F. |

Fuel Water Injection Pump

| | |
|---------------|-----------------|
| Type | Reciprocating |
| Capacity | 0.48 GPM (max.) |
| Suction Pres. | 0 to 350 Psig. |
| Disc Pres. | 450 Psig. |
| Suction Temp. | 100 to 200°F. |

V. PLANT DESIGN - contd.

Use 0.75 HP electric motor drive with speed control turn down of 20 to 1.0 Duplex pump with methanol in one cylinder and condensate in the other cylinder.

c. Condensate Makeup Pump

| | |
|---------------|-----------------|
| Type | Reciprocating |
| Capacity | 0.20 GPM (Max.) |
| Suction Pres. | 0 - 10 Psig. |
| Disc. Pres. | 350 Psig. |
| Suction Temp. | 100 - 140°F. |

Use 0.25 HP electric motor drive with speed control turn down of 20 to 1.0.

d. Oxygen Pump

| | |
|---------------|----------------------------------|
| Type | Reciprocating |
| Capacity | 0.50 GPM (Max.) |
| Suction Pres. | 25 Psig. (for NPSH requirements) |
| Disc. Pres. | 450 Psig. |
| Suction Temp. | -297.6°F. |

Use 0.75 HP electric motor drive with speed control turn down of 20 to 1.0.

e. Aqueous Methanol Feed Preheater

| | |
|--------------|-----------------------|
| Type | Shell and Tube |
| Design Pres. | 500 Psig. |
| Design Temp. | 850°F. |
| Duty | 176,800 Btu/hr. |
| Surface | 15.4 ft. ² |
| Material | Type 304 S.S. |

f. Aqueous Methanol Feed Vaporizer

| | |
|--------------|-----------------------------------|
| Type | Coil in Shell |
| Design Pres. | 500 Psig. (Coil) 450 Psig (Shell) |
| Design Temp. | 1200°F. (Coil) 450°F. (Shell) |
| Duty | 722,700 Btu/hr. |
| Surface | 36.1 Ft. ² |
| Material | Type 347 S.S. (Coil) C.S. (Shell) |

g. Reformer

| | |
|---------------------|---|
| Type | Double Pipe |
| Dimension | 4" Sch. 40 Outer Pipe x 10'-6" Catalyst Depth, 2" Sch. 40 Inner Pipe |
| Catalyst in Annulus | 0.61 Ft. ³ |
| Number of Units | 8 |
| Design Pres. | 450 Psig. (Outer Pipe), 400 Psig. (Inner Pipe) |
| Design Temp. | 1000°F. (Outer Pipe), 1600°F. (Inner Pipe) |
| Material | Type 347 S.S. |

V. PLANT DESIGN - contd.

- h. Flue Gas Cooler
 - Type Shell and Tube
 - Design Pres. 400 Psig.
 - Design Temp. 600 °F.
 - Duty 821,200 Btu/hr.
 - Surface Area 39.7 Ft.²
 - Material Type 304 S.S.

- i. Palladium Hydrogen Diffusion Cells
 - Type J. Bishop Type A-71
 - Number 64

- j. Methanator
 - Type Vertical Cylinder
 - Design Pres. 50 Psig.
 - Design Temp. 800°F.
 - Dimensions 18" OD x 4'-6" TT
 - Material Type 347 S.S.
 - Catalyst Girdler Type G-33 (4.43 ft.³)

- k. Saturator
 - Type Vertical Cylinder
 - Design Pres. 50 Psig.
 - Design Temp. 650°F.
 - Dimensions 12 Sch. 40 Pipe x 4'-0" TT
 - Material Type 304 S.S.

- l. Separator
 - Type Vertical Cylinder
 - Design Pres. 400 Psig.
 - Design Temp. 650°F.
 - Dimensions 8" Sch. 40 Pipe x 3'-0" TT
 - Material Type 304 S.S.

V. PLANT DESIGN - contd.

C. Mechanical Details of Major Equipment

Five semi-detailed sketches have been prepared to depict the physical characteristics of the principal process equipment components. These are:

| | |
|------------------|----------------|
| Figure No. V-C-1 | Methanator |
| Figure No. V-C-2 | Saturator |
| Figure No. V-C-3 | Feed Vaporizer |
| Figure No. V-3-4 | Reformer |
| Figure No. V-C-5 | Separator |

The assembly of these process equipment components together with pumps and heat exchangers into the given available space is shown in the following three scale study drawings:

| | |
|------------------|------------------------------------|
| Figure No. V-C-6 | Hydrogen Generator, Plan View |
| Figure No. V-C-7 | Hydrogen Generator, Elevation |
| Figure No. V-C-8 | Hydrogen Generator, Isometric View |

D. Instrumentation

The hydrogen gas production rate of the hydrogen generator is set by adjustment of the speed of the process methanol and condensate feed metering pumps. This speed adjustment can be achieved by a locally-mounted manual loading station or remotely in response to the submarine command instructions to a computer control center. The computer control center may contain an analog or other type computer which receives feedback intelligence data from the individual control instruments including, but not limited to:

1. Temperature of process gas leaving reformer.
2. Oxygen and carbon monoxide concentration in flue gas leaving methanol feed vaporizer.
3. Speed controller of fuel methanol and of oxygen pump.
4. Condensate level switch at flue gas cooler separator.

The computer routine is programmed to regulate and to maintain the process conditions and variables as required for optimum hydrogen production at the set rate. The temperature of the process gas leaving the reformer is controlled by adjusting the speed of the fuel and condensate metering pumps.

The combustion is controlled by measuring the speed of the methanol fuel pump, the speed of the oxygen pump and the oxygen and carbon monoxide content of the flue gas. The signals from these measurements

V. PLANT DESIGN - contd.

feed back to the computer and an output signal is sent to an oxygen fuel ratio controller. This controller then controls the speed of the oxygen pump.

Two back pressure regulators are provided to maintain pressure on both the process gas and the flue gas side of the reformer. The level switch on the condensate separator will supply a signal which can be made to adjust the speed controller governing the speed of the condensate makeup pump.

The anticipatory characteristics of the computer control center, and the other control components will be selected so that lag time will be minimized when a change in rate order is issued by the submarine command or whenever any process condition tends to deviate from the respective optimum condition required by the established production rate. However, it is anticipated that at times, an extremely rapid increase in rate of hydrogen production may be required by the submarine command. The normal processes of increase in combustion of vaporizer fuel and heat transfer rate to the reforming catalyst chamber may not be sufficiently rapid to satisfy these extreme requirements. To satisfy this heavier demand extra heat input directly to the catalytic reactor can be obtained by means of injecting reactant oxygen directly into the methanol-water vapor mixture entering the reactor. The duration of the periods of oxygen injection and consequent heat generation from oxidation of methanol will be very short. The oxygen injection assist will cease as soon as the rate of heat transfer from the flue gas is sufficient to maintain satisfactory process conditions at the increased hydrogen rate. To prevent any deficiency in oxygen flow to the feed vaporizer burner during oxygen injection the computer program routine will be devised to increase the oxygen pump speed sufficiently to maintain sufficient oxygen flow for all requirements. At the same time, the process methanol feed stream will be increased sufficiently for both the feed for increased hydrogen production and the portion which will react with the injected oxygen.

A temperature switch is located at the outlet of the methanator to actuate a high temperature alarm. This alarm warns of leakage of impurities into the product hydrogen stream leaving the purifier cell. This switch may also send a feedback signal to the computer control center to shut down the hydrogen generator if continued excessively high temperature of the hydrogen product gas should endanger the fuel cells.

It is contemplated that over a period of time the dynamic characteristics of the unit may drift somewhat due to various factors such as catalyst aging, wear or heat loss variation. With a completely computerized system the control program could be self correcting to maintain optimum performance. This would be a goal for the future after operational experience is gained. In the immediate stage of development an arbitrary correction can be built into the control system based on data obtained from the proposed prototype program.

V. PLANT DESIGN - contd.

E. Physical

The approximate weight and size of the principal items of process equipment have been estimated to be as follows:

| EQUIPMENT REFERENCE FIGURES (NO. V-C-6,-7,-8) | DESCRIPTION | WEIGHT POUNDS | DIMENSIONS | VOLUME CUBIC FT. |
|--|---|------------------|-----------------------------------|---------------------|
| 1 | Reformer and Hydrogen Purifier Cell Units | 3000 | 1'-3" x 5'-9" x 12'-10" | 92.5 |
| 2 | Methanator | 740 | 18" O.D. x 3'-10" Tangent to head | 6.8 |
| 3 | Aqueous Methanol feed vaporizer | 3830 | 37 1/2" O.D. x 7'-3" approx. | 59 |
| 4 | Oxygen vaporizer | 80 | 6" x 4'-0" x 1'-3" | 2.5 |
| 5 | Aqueous methanol feed preheater | 400 | 15" O.D. x 6'-0" | 7.4 |
| 6 | Flue Gas cooler | 500 | 18" O.D. x 6'-0" | 10.6 |
| 7 | Separator | 130 | 9" O.D. x 3'-0" | 1.4 |
| 8 | Direct contact cooler saturator | 260 | 13" O.D. x 4'-0" | 3.7 |
| 9 | Process Methanol Feed Pump | 625 | 2'-6" x 1'-7" x 1'-6" | 6.0 |
| 10 | Process Condensate Feed Pump | 625 | 2'-6" x 1'-7" x 1'-6" | 6.0 |
| 11 | Fuel Methanol Pump | 440 | 2'-6" x 1'-7" x 1'-6" | 6.0 |
| 12 | Fuel Water Injection pump | 440 | 2'-6" x 1'-7" x 1'-6" | 6.0 |
| 13 | Condensate make-up pump | 200 | 1'-9" x 3'-0" x 1'-3" | 6.6 |
| | | 11,270 | | |
| (Offsite) | Oxygen Pump | 400 | | |

C-5414-1

DRAWING NUMBER

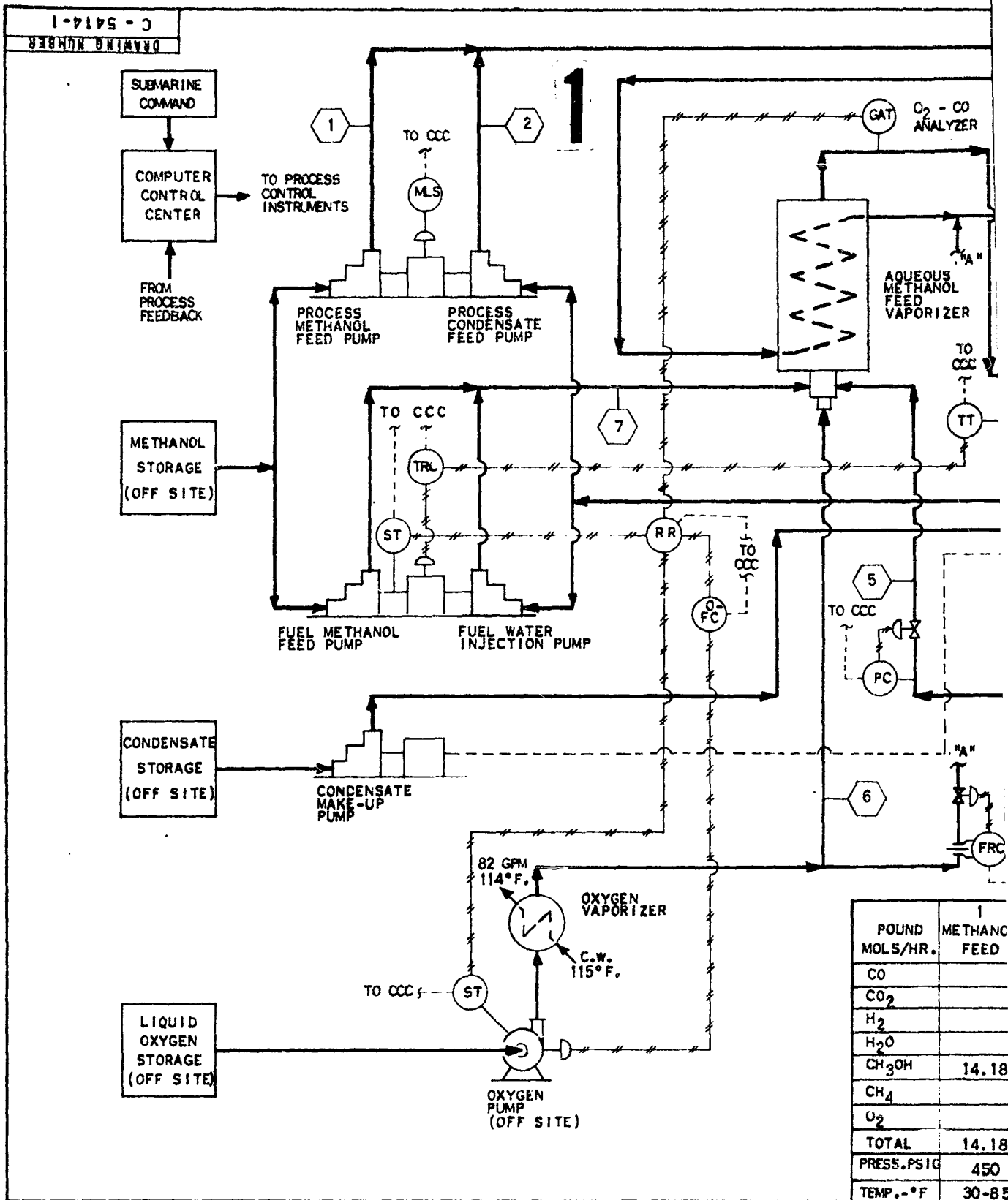

| POUND MOLLS/HR. | 1 METHANOL FEED |
|--------------------|-----------------|
| CO | |
| CO ₂ | |
| H ₂ | |
| H ₂ O | |
| CH ₃ OH | 14.18 |
| CH ₄ | |
| O ₂ | |
| TOTAL | 14.18 |
| PRESS. PSIG | 450 |
| TEMP. °F | 30-85 |

2

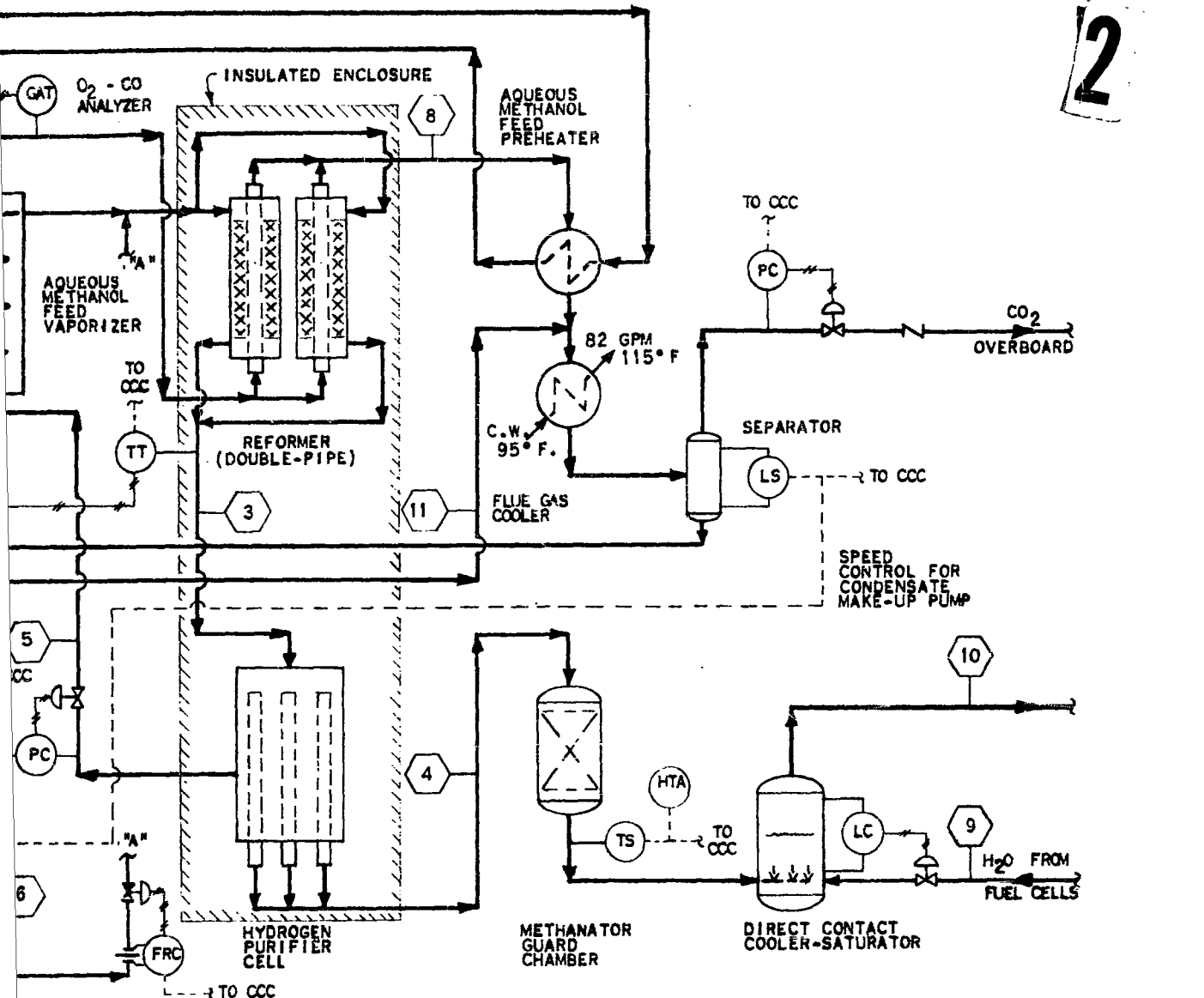

- GAT -
- HTA -
- LC -
- LS -
- MLS -
- O-FC -
- PC -
- RR -
- ST -
- TR -
- TRC -
- TS -
- TT -
- CCC -
- FRC -

| | |
|-----|------|
| No. | DATE |
| | |

This drawing is the without consideration copied, lent, or distributed for which it is

| | 1 | 2 | 3 | 4 | 5 | 6 | 7 | 8 | 9 | 10 | 11 | |
|--------------------|---------------|------------|-------------------|----------------------|-----------|--------|--------|----------|------------|----------------------------------|--------------------|--|
| POUND MOL/HR. | METHANOL FEED | WATER FEED | REFORMER EFFLUENT | DRY HYDROGEN PRODUCT | PURGE GAS | OXYGEN | FUEL | FLUE GAS | CONDENSATE | SATURATED H ₂ PRODUCT | MAKE-UP CONDENSATE | |
| CO | | | 2.62 | | 2.62 | | | | | | | |
| CO ₂ | | | 11.08 | | 11.08 | | | 16.96 | | | | |
| H ₂ | | | 38.05 | 35.00 | 3.05 | | | | | 35.0 | | |
| H ₂ O | | 28.36 | 17.71 | | 17.71 | | 12.51 | 39.79 | 7.5 | 7.5 | 1.66 | |
| CH ₃ OH | 14.18 | | 0.06 | | 0.06 | | 2.78 | | | | | |
| CH ₄ | | | 0.43 | | 0.43 | | | | | | | |
| O ₂ | | | | | | 7.94 | | | | | | |
| TOTAL | 14.18 | 28.36 | 69.95 | 35.00 | 34.95 | 7.94 | 15.29 | 56.75 | 7.5 | 42.5 | 1.66 | |
| RESS. PSIG | 450 | 450 | 425 | 5-10 | 415 | 450 | 450 | 360 | 10 | 1-2 | 360 | |
| EMP. °F | 30-85 | 60-200 | 700 | 700 | 700 | 60 | 60-200 | 800 | 140 | 140 | 140 | |

GIR

SCALE

DRAWN WILDA

CHECKER

NO. BUREAU U. S. CONTRACT NO.

LEGEND

- GAT - GAS ANALYZER TRANSMITTER
- HTA - HIGH TEMPERATURE ALARM
- LC - LEVEL CONTROL
- LS - LEVEL SWITCH
- MLS - MANUAL LOAD STATION
- O-FC - O₂ FUEL CONTROL
- PC - PRESSURE CONTROL
- RR - RATIO RELAY
- ST - SPEED TRANSMITTER
- TR - TEMPERATURE RECORDER
- TRC - TEMPERATURE RECORDING CONTROLLER
- TS - TEMPERATURE SWITCH
- TT - TEMPERATURE TRANSMITTER
- > INSTRUMENT AIR
- - -> ELECTRICAL
- CCC - COMPUTER CONTROL CENTER
- FRC - FLOW RECORDER CONTROLLER

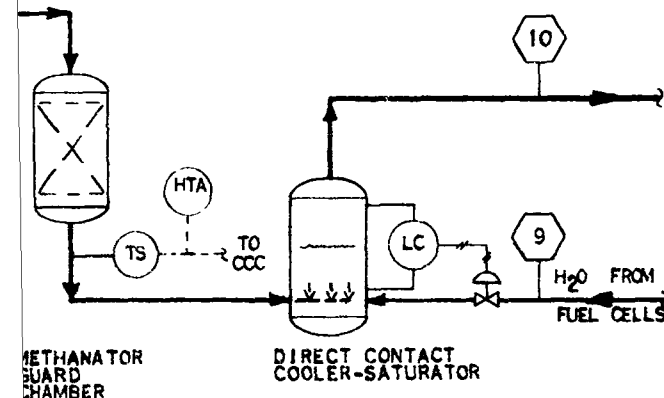
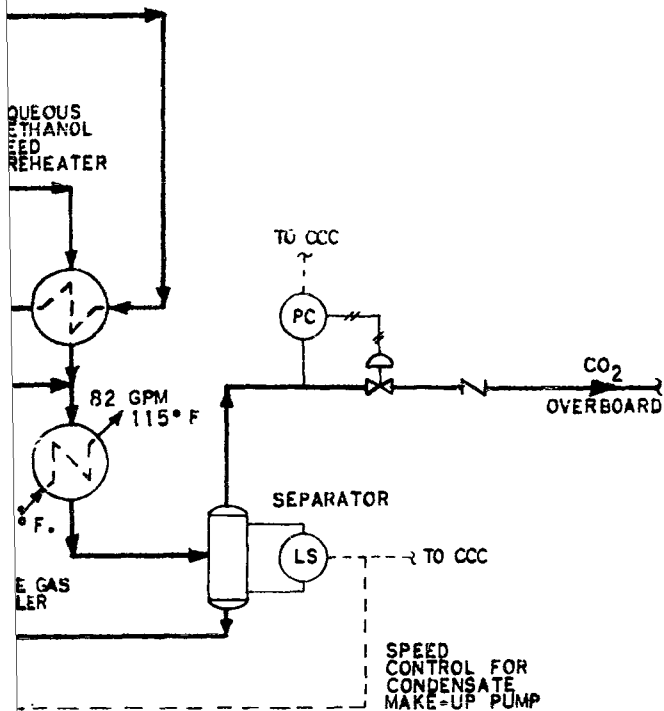

| NO. | DATE | REVISION | BY | CHK. | ING. |
|-----|------|----------|----|------|------|
| | | | | | |

This drawing is the property of Girdler Corporation, Louisville, Kentucky and is lent without consideration other than the borrower's agreement that it shall not be reproduced, copied, lent, or disposed of directly or indirectly nor used for any purpose other than that for which it is specifically furnished. This print is lent subject to return on demand.

| 5 | 6 | 7 | 8 | 9 | 10 | 11 |
|----------|--------|--------|----------|------------|----------------------------------|--------------------|
| URGE GAS | OXYGEN | FUEL | FLUE GAS | CONDENSATE | SATURATED H ₂ PRODUCT | MAKE-UP CONDENSATE |
| 2.62 | | | | | | |
| 1.08 | | | 16.96 | | | |
| 3.05 | | | | | 35.0 | |
| 7.71 | | 12.51 | 39.79 | 7.5 | 7.5 | 1.66 |
| 0.06 | | 2.78 | | | | |
| 0.43 | | | | | | |
| | 7.94 | | | | | |
| 4.95 | 7.94 | 15.29 | 56.75 | 7.5 | 42.5 | 1.66 |
| 415 | 450 | 450 | 360 | 10 | 1-2 | 360 |
| 700 | 60 | 60-200 | 800 | 140 | 140 | 140 |

GIRDLER CORPORATION
LOUISVILLE, KENTUCKY

| | |
|-----------------------|------------------------------|
| SCALE | DESIGNER |
| DRAWN WILDMAN 10-2-62 | GROUP HEAD HCS/CSG 10-3-62 |
| CHECKER | JOB ENGINEER RLH/RAB 10-3-62 |

FIGURE NO. **V-A-1**
PROCESS FLOW DIAGRAM
HYDROGEN GENERATOR
FOR FUEL CELL

| | | |
|--|-------------------------------------|------------------|
| FOR: BUREAU OF SHIPS U. S. NAVY CONTRACT NOs 86743 (FBM) | DRAWING NUMBER C - 5414-1 | REV. 0 |
|--|-------------------------------------|------------------|



 10 X 10 TO THE CM 359-14
 KRUPP, A. S. THYSSEN, AG

FIGURE 17-B-1
 TEMPERATURE - HEAT LOAD DIAGRAM

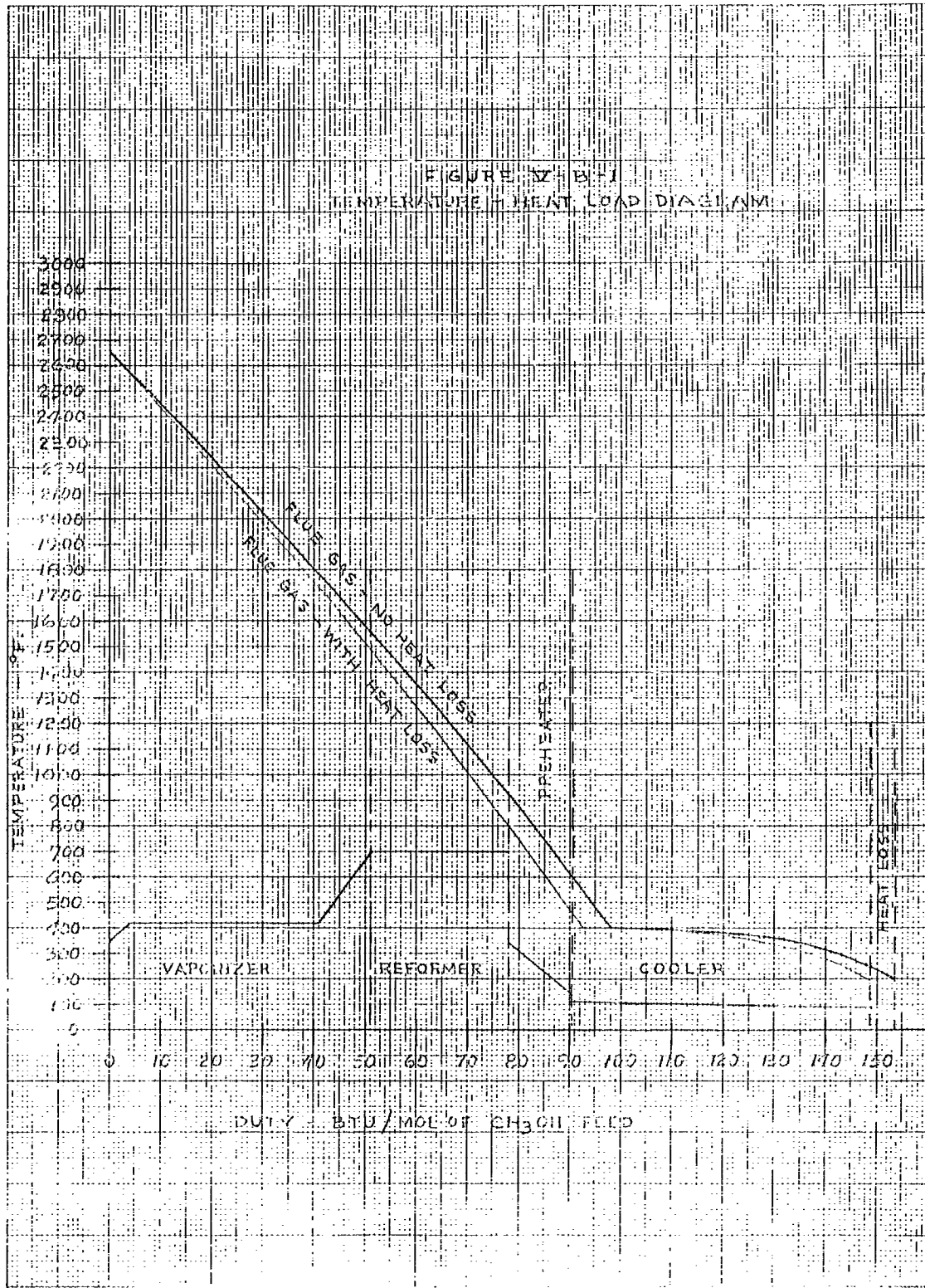

GIBLER CORPORATION
 LOUISVILLE, KENTUCKY

FOR: BUREAU OF SHIPS
 U. S. NAVY

DRAWING NUMBER
 A-41378-1

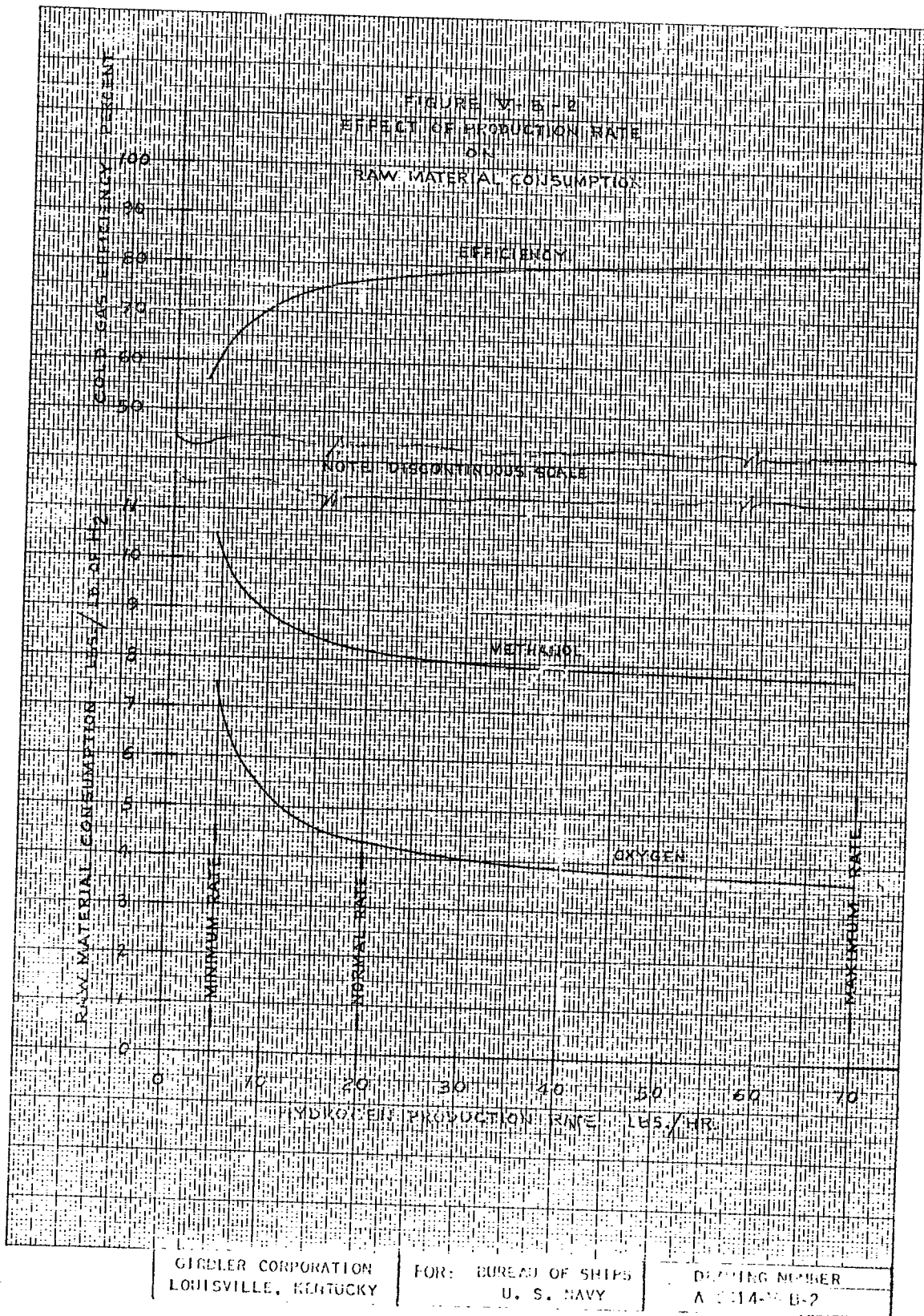

THIS DRAWING IS THE PROPERTY OF GIRDLER CORPORATION, LOUISVILLE, KENTUCKY, AND IS LENT WITHOUT CONSIDERATION OTHER THAN THE BORO-
 ROWER'S AGREEMENT THAT IT SHALL BE REPRODUCED, COPIED, LENT, OR
 DISPOSED OF, DIRECTLY OR INDIRECTLY, FOR ANY PURPOSE OTHER
 THAN THAT SPECIFICALLY FURNISHED. THIS PRINT IS LENT
 SUBJECT TO RETURN ON DEMAND.

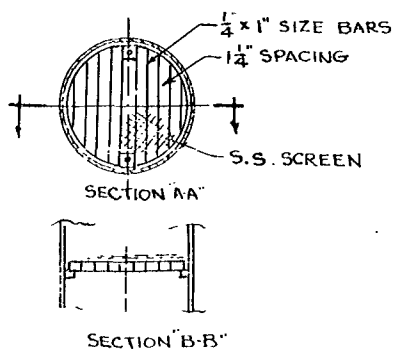
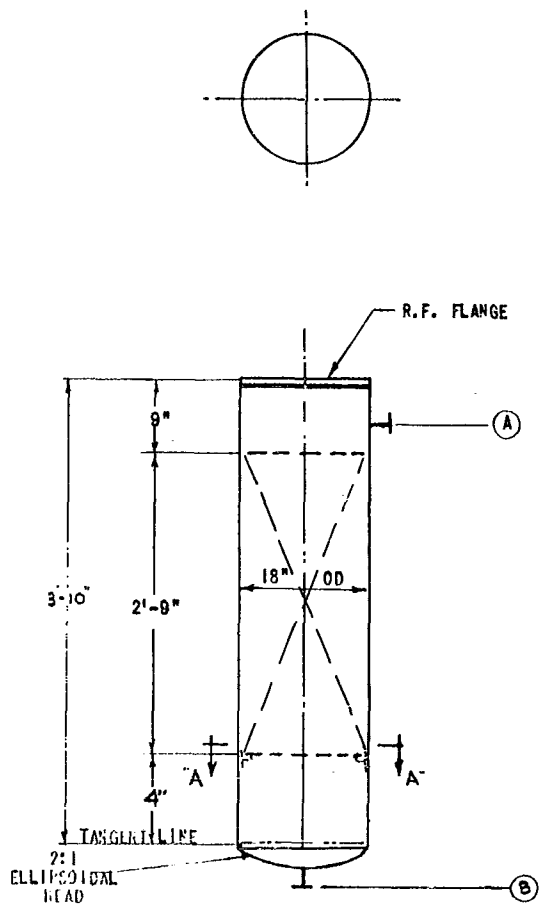

DESIGN DATA

PRESS., NORMAL OPERATING (10-20 PSIG)
 PRESS., INTERNAL DESIGN 50 PSIG
 PRESS., EXTERNAL DESIGN 0 PSIG
 PRESS., HYDROSTATIC TEST 600°F
 TEMP., NORMAL OPERATING 750°F
 TEMP., DESIGN 0
 CORROSION ALLOWANCE 0
 SPECIFICATIONS: MILITARY MIL-S-901B (NAVY) 16 SEPT 1958
 CODES: ASME SECTION VIII
 STAMP AND REGISTRATION: YES
 INSPECTION BY: GIRDLER AND U. S. NAVY
 WIND/EARTHQUAKE LOADINGS: NONE
 HEAT TREATMENT: NONE
 RADIOGRAPHING: SPOT

MATERIALS:
 SPEC. REF.: ASME CODE
 SHELL: SA-240 TYPE 304
 HEADS: SA-240 TYPE 304
 NOZ. FLANGE: SA-182 GRADE F 304
 " NECK: SA-312 GRADE TYPE 304
 " BOLTS/NUTS: SA-193 B7/SA-194 2H
 " GASKETS: FLEXITALLIC

COUPLINGS:
LINING:
INTERNALS: (EX. BED PACKING)
 PIPE: MK REFERENCE FOR DETAILS
 PLATE: 304 STAINLESS
 SHAPES: 304
 SCREEN: 304
 BOLTS: 304
 NUTS: 304
 GASKETS:
 PACKING:
 TRAYS:
BED PACKING:
EXTERNALS:
 SUPPORT:
 LUGS:

PAINT:
 INTERNAL: NONE
 EXTERNAL: NONE

INSULATION:
WEIGHTS:
 EMPTY: ESTIMATED CALCULATED FINAL
 OPERATING:
TEST:

| MK | NO | SIZE | NAME | FLANGE | | COUPLING | |
|----|----|------|------------|--------|-----------|----------|------|
| | | | | PRESS | TYP. FACE | PRESS | TYP. |
| A | | | GAS INLET | 150# | R.F. | | |
| B | | | GAS OUTLET | 150# | R.F. | | |
| C | | | | | | | |
| D | | | | | | | |
| E | | | | | | | |
| F | | | | | | | |
| G | | | | | | | |
| J | | | | | | | |
| K | | | | | | | |
| L | | | | | | | |
| N | | | | | | | |
| P | | | | | | | |
| O | | | | | | | |
| R | | | | | | | |
| S | | | | | | | |
| X | | | | | | | |
| Y | | | | | | | |
| Z | | | | | | | |
| HH | | | | | | | |
| MH | | | | | | | |

NOTES:
 NO. DATE REVISION BY CHK ENG
 DR BY J. H. 9 28 62 HEAD
 CHA BY J. H. 10 1 62
 DESK J. H. 10 28 62

CERTIFIED FOR DESIGN

GC 62-10

| | | | | |
|--|-----------------------|--|-------------------------------|--------------|
| GIRDLER CORPORATION LOUISVILLE, KENTUCKY | FOR U. S. NAVY | 18" O.D. X 3'-10" MECHANATOR | DRAWING NO. A-5414-101 | RLV 0 |
|--|-----------------------|--|-------------------------------|--------------|

FIGURE NO. V-C-1

THIS DRAWING IS THE PROPERTY OF GIRDLER CORPORATION, LOUISVILLE, KENTUCKY, AND IS LENT WITHOUT COPIES TO THE USER. IT IS TO BE RETURNED TO THE LENDER AT THE END OF THE TERM OF THE LENT. NO REPRODUCTION, EITHER WHOLLY OR IN PART, IS TO BE MADE WITHOUT THE WRITTEN PERMISSION OF GIRDLER CORPORATION. THIS PRINT IS LENT SUBJECT TO RETURN ON DEMAND.

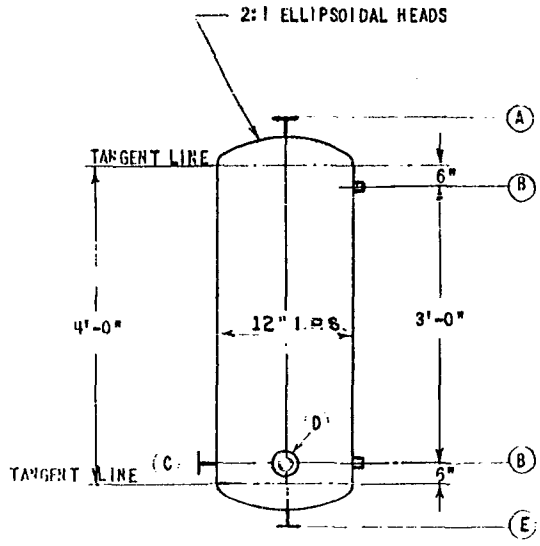
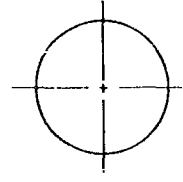

DESIGN DATA

PRESS. NORMAL OPERATING: 50 PSIG
 PRESS. INTERNAL DESIGN: 50 PSIG
 PRESS. EXTERNAL DESIGN: 50 PSIG
 PRESS. HYDROSTATIC TEST: 50 PSIG
 TEMP. NORMAL OPERATING: 650°F
 TEMP. DESIGN: 0
 CORROSION ALLOWANCE: 0
 SPECIFICATIONS: MILITARY MIL-S 901B (NAVY) 16 SEPT 1958
 CODES: ASME SECTION VIII
 STAMP AND REGISTRATION: YES
 INSPECTION BY: GIRDLER AND U.S. NAVY
 WIND/EARTHQUAKE LOADINGS: NONE
 HEAT TREATMENT: NONE
 RADIOGRAPHING: SPOT

MATERIALS:

SPEC. REF.: ASME CODE
 SHELL: SA-240 TYPE 304
 HEADS: SA-240 TYPE 304
 NOZ FLANGE: SA-182 GRADE F 304
 " NECK: SA-312 GRADE TYPE 304
 " BOLTS/NUTS: SA-193 B7/SA-194 2H
 " GASKETS: COP-PRESSED ASBESTOS

COUPLINGS:

LINING

INTERNALS: (EX. BED PACKING)

| PIPE | MK. | REFERENCE FOR DETAILS. |
|---------|-----|------------------------|
| PLATE | | |
| SHAPES | | |
| SCREEN | | |
| BOLTS | | |
| NUTS | | |
| GASKETS | | |
| PACKING | | |
| TRAYS | | |

BED PACKING

EXTERNALS

SUPPORT

LUGS

PAINT:

INTERNAL: NONE

EXTERNAL: NONE

INSULATION:

ESTIMATED

WEIGHTS:

EMPTY

OPERATING

TEST:

ESTIMATED

CALCULATED FINAL

| MK | NO | SIZE | OPENING SCHEDULE | NAME | FLANGE | | COUPLING | |
|----|----|--------|------------------|-------------|--------|-----------|----------|------|
| | | | | | PRSS | TYP. FACE | PRSS | TYP. |
| A | 1 | | | GAS OUTLET | 150# | | | |
| B | 2 | 2 3/4" | | LC COIN | | | 2000# | |
| C | 1 | | | GAS INLET | 150# | | | |
| D | 1 | | | WATER INLET | 150# | | | |
| E | 1 | | | DRAIN | 150# | | | |
| F | | | | | | | | |
| G | | | | | | | | |
| H | | | | | | | | |
| I | | | | | | | | |
| J | | | | | | | | |
| K | | | | | | | | |
| L | | | | | | | | |
| M | | | | | | | | |
| N | | | | | | | | |
| O | | | | | | | | |
| P | | | | | | | | |
| Q | | | | | | | | |
| R | | | | | | | | |
| S | | | | | | | | |
| T | | | | | | | | |
| U | | | | | | | | |
| V | | | | | | | | |
| W | | | | | | | | |
| X | | | | | | | | |
| Y | | | | | | | | |
| Z | | | | | | | | |
| AA | | | | | | | | |
| AB | | | | | | | | |

NOTES:

FIGURE NO. V-C-2

GIRDLER CORPORATION
LOUISVILLE, KENTUCKY

FOR U. S. NAVY

12" I.P.S. X 4'-0"
SATURATOR

BLAWING IN
5414-102

NO. DATE: 1978
BY: [Signature]
CHK: [Signature]
CERTIFIED FOR DES: [Signature]

THIS DRAWING IS THE PROPERTY OF GIRDLER CORPORATION, LOUISVILLE, KENTUCKY, AND IS LOANED TO YOU WITHOUT CONSIDERATION OTHER THAN THE BORROWER'S OBLIGATION TO RETURN IT TO THE LENDER. IT IS NOT TO BE REPRODUCED, COPIED, LENT OR IN ANY MANNER MADE PUBLIC IN WHOLE OR IN PART, OR FOR ANY PURPOSE OTHER THAN THAT FOR WHICH IT IS SPECIFICALLY FURNISHED. THIS PRINT IS LOANED SUBJECT TO RETURN ON DEMAND.

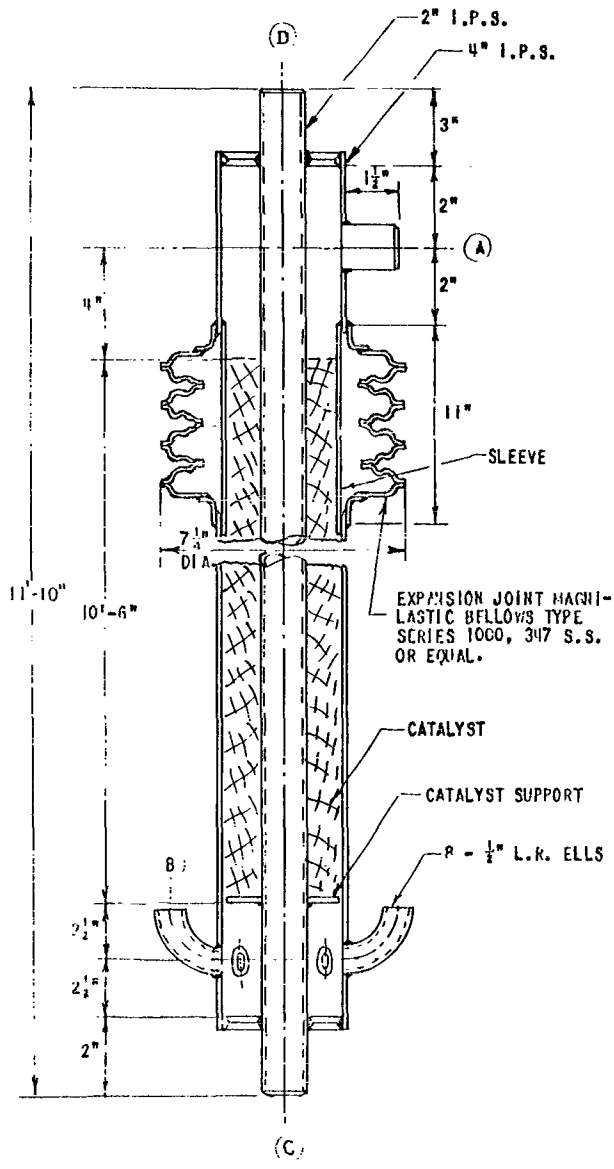

FIGURE NO. V-C-4

| DESIGN DATA | | VESSEL | JACKET | COIL OR TUBE |
|--------------------------|----------------------------|----------|--------|--------------|
| PRESS., NORMAL OPERATING | | 450 PSIG | | 400 PSIG |
| PRESS., INTERNAL DESIGN | | | | |
| PRESS., EXTERNAL DESIGN | | | | |
| PRESS., HYDROSTATIC TEST | | | | |
| TEMP., NORMAL OPERATING | | 500° F | | 1600° F |
| TEMP., DESIGN | | 0 | | 0 |
| CORROSION ALLOWANCE | | | | |
| SPECIFICATIONS | MILITARY MIL-S 901B (NAVY) | | | 16 SEPT 1953 |
| CODES | ASME SEC. VIII (SHELL) | | | |
| STAMP AND REGISTRATION | | YES | | |
| INSPECTION BY | GIRDLER AND U.S. NAVY | | | |
| WIND-EARTHQUAKE LOADINGS | | NO | | |
| HEAT TREATMENT | | NO | | |
| RADIOGRAPHING | | SPOT | | |

| MATERIALS | | ASME CODE | |
|----------------------------|------------------|-------------------------|-----------------------|
| SPEC. REF. | | SA-312 TP 304 STAINLESS | |
| SHELL | | SA-240 TYPE 304 | |
| HEADS | | | |
| NOZ. FLANGE | | SA-312 TP 304 SEAMLESS | |
| NECK | | | |
| BOLTS/NUTS | | | |
| GASKETS | | | |
| COUPLINGS | | | |
| LINING | | | |
| INTERNAL (EX. BED PACKING) | | | |
| PIPE | SA-312 TP 310 | MK | REFERENCE FOR DETAILS |
| PLATE | SA-240 TYPE 310S | | |
| SHAPES | | | |
| SCREEN | | | |
| BOLTS | | | |
| NUTS | | | |
| GASKETS | | | |
| PACKING | | | |
| TRAYS | | | |
| BED PACKING | | | |
| EXTERNAL | | | |
| SUPPORT | | | |
| LUGS | | | |
| PAINT | | | |
| INTERNAL | | | |
| EXTERNAL | | | |
| INSULATION | | | |
| WEIGHTS | | ESTIMATED | CALCULATED FINAL |
| EMPTY | | | |
| OPERATING | | | |
| TEST | | | |

| MARK | NO. | DATE | NAME | FLANG | | COUPLING | |
|------|-----|---------|--------------------|--------|-----------|----------|------|
| | | | | PRESS. | TYP. FACE | PRESS. | TYP. |
| A | 1 | | PROCESS GAS INLET | | | | |
| B | 8 | 10-2-62 | PROCESS GAS OUTLET | | | | |
| C | 1 | | FLUE GAS INLET | | | | |
| D | 1 | | FLUE GAS OUTLET | | | | |
| E | | | | | | | |
| F | | | | | | | |
| G | | | | | | | |
| H | | | | | | | |
| I | | | | | | | |
| J | | | | | | | |
| K | | | | | | | |
| L | | | | | | | |
| M | | | | | | | |
| N | | | | | | | |
| O | | | | | | | |
| P | | | | | | | |
| Q | | | | | | | |
| R | | | | | | | |
| S | | | | | | | |
| T | | | | | | | |
| U | | | | | | | |
| V | | | | | | | |
| W | | | | | | | |
| X | | | | | | | |
| Y | | | | | | | |
| Z | | | | | | | |
| AA | | | | | | | |
| AB | | | | | | | |

8 REQUIRED PER UNIT

| NO. | DATE | REVISION | BY | CHK | ENG |
|-----|---------|----------|----------|-----|-----|
| 1 | 10-2-62 | HEAD | J. L. G. | | |
| 2 | 10-2-62 | | | | |

CERTIFIED FOR DESIGN

THIS DRAWING IS THE PROPERTY OF GARDNER CORPORATION, LOUISVILLE, KENTUCKY AND IS LOANED TO YOU WITHOUT CONSIDERATION OTHER THAN THE BORROWER'S AGREEMENT THAT IT SHALL NOT BE REPRODUCED, COPIED, LENT OR IN ANY MANNER BE MADE PUBLIC IN ANY MANNER WITHOUT THE SPECIFIC WRITTEN PERMISSION OF GARDNER CORPORATION. THIS PRINT IS LOANED SUBJECT TO RETURN ON DEMAND.

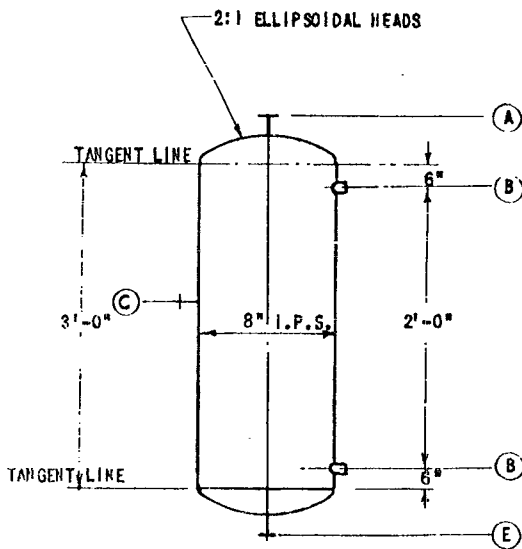
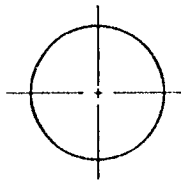

FIGURE NO. V-C-5

DESIGN DATA

PRESS. NORMAL OPERATING _____
 PRESS. INTERNAL DESIGN 400 PSIG
 PRESS. EXTERNAL DESIGN 0 PSIG
 PRESS. HYDROSTATIC TEST _____
 TEMP. NORMAL OPERATING _____
 TEMP. DESIGN 650° F
 CORROSION ALLOWANCE _____
 SPECIFICATIONS: MILITARY MIL-S 901B (NAVY) 16 SEPT 1958
 CODES: ASME SECTION VIII
 STAMP AND REGISTRATION: YES
 INSPECTION BY: GIRDLER AND U.S. NAVY
 WIND/EARTHQUAKE LOADINGS: NONE
 HEAT TREATMENT: NONE
 RADIOGRAPHING: SPOT

MATERIALS:
 SPEC. REF.: ASME CODE
 SHELL: SA-240 TYPE 304
 HEADS: SA-240 TYPE 304
 NOZ. FLANGE: SA-182 GRADE F 304
 " NECK: SA-312 GRADE TYPE 304
 " BOLTS/NUTS: SA-193 B7/SA-194 2H
 " GASKETS: COMPRESSED ASBESTOS

COUPLINGS:
LINING:
 INTERNALS: (EX. BED PACKING)
 PIPE: _____
 PLATE: _____
 SHAPES: _____
 SCREEN: _____
 BOLTS: _____
 NUTS: _____
 GASKETS: _____
 PACKING: _____
 TRAYS: _____
 BED PACKING: _____
 EXTERNALS: _____
 SUPPORT: _____
 LUGS: _____
PAINT:
 INTERNAL: NONE
 EXTERNAL: NONE
INSULATION:
WEIGHTS:
 EMPTY: _____
 OPERATING: _____
TEST:

| MK | NO | SIZE | OPENING SCHEDULE | | FLANGE | | COUPLING | |
|----|----|------|------------------|-------|-----------|-------|----------|--|
| | | | NAME | PRESS | TYP. FACE | PRESS | TYP. | |
| A | 1 | 3/4" | GAS OUTLET | 300# | | | | |
| B | 2 | 3/4" | LC CO'N | | | | 3000# | |
| C | 1 | | GAS INLET | 300# | | | | |
| D | | | | | | | | |
| E | | | | | | | | |
| F | | | DRAIN | 300# | | | | |
| G | | | | | | | | |
| H | | | | | | | | |
| I | | | | | | | | |
| J | | | | | | | | |
| K | | | | | | | | |
| L | | | | | | | | |
| M | | | | | | | | |
| N | | | | | | | | |
| O | | | | | | | | |
| P | | | | | | | | |
| Q | | | | | | | | |
| R | | | | | | | | |
| S | | | | | | | | |
| T | | | | | | | | |
| U | | | | | | | | |
| V | | | | | | | | |
| W | | | | | | | | |
| X | | | | | | | | |
| Y | | | | | | | | |
| Z | | | | | | | | |
| HH | | | | | | | | |
| MH | | | | | | | | |

NOTES:
 NO. _____
 REVISION:
 BY: _____
 CHECK: _____
 CERTIFIED FOR DESIGN: _____

| | | | |
|---|-------------------|--------------------------------|--------------------------|
| GIRDLER CORPORATION LOUISVILLE, KENTUCKY | FOR U. S. NAVY | 8" I.P.S. X 3'-0" SEPARATOR | DRAWING NO. 5-114-103 |
|---|-------------------|--------------------------------|--------------------------|

EQUIPMENT LEGEND

- ① REFORMER AND HYDROGEN PURIFIER CELL UNITS
- ② METHANATOR
- ③ AQUEOUS METHANOL FEED VAPORIZER
- ④ OXYGEN VAPORIZER
- ⑤ AQUEOUS METHANOL FEED PREHEATER
- ⑥ FLUE GAS COOLER
- ⑦ SEPARATOR
- ⑧ DIRECT CONTACT COOLER SATURATOR
- ⑨ PROCESS METHANOL FEED PUMP
- ⑩ PROCESS CONDENSATE FEED PUMP
- ⑪ FUEL METHANOL PUMP
- ⑫ FUEL WATER INJECTION PUMP
- ⑬ CONDENSATE MAKE-UP PUMP

THIS DRAWING IS THE PROPERTY OF GIRDLER CORPORATION, LOUISVILLE, KENTUCKY, AND IS LENT WITHOUT CONSIDERATION OTHER THAN THE BORO-
 ROWER'S AGREEMENT THAT IT SHALL BE REPRODUCED OR USED FOR ANY PURPOSE OTHER
 THAN THAT FOR WHICH IT IS SPECIFICALLY FURNISHED. THIS PRINT IS LENT
 SUBJECT TO RETURN ON DEMAND.

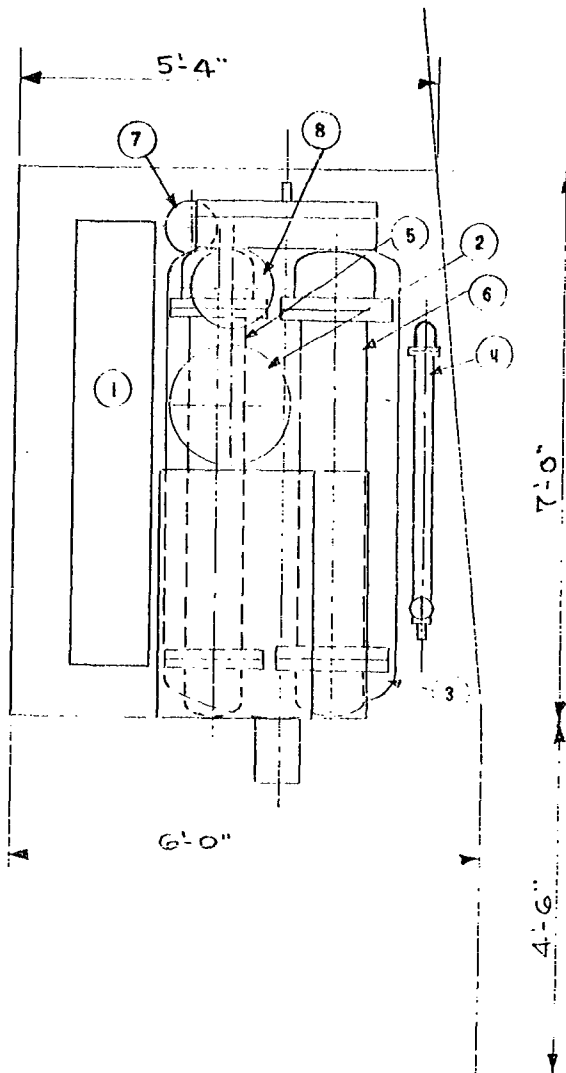

BULKHEAD

PLAN VIEW OF PORT SIDE GENERATOR

NOTE 1:
 STARBOARD SIDE VIEW IS SIMILAR EXCEPT REVERSED TO SUIT
 CONFIGURATION OF SPACE.
 REFERENCE: PC. NO. 5, SKETCH 434; 66/562:1205 CH.3, DATED 8-23-61

FIGURE NO. V-C-6

SCALE: 1/2" = 1'-6"

| | | | | |
|-----|------|----|-------|------|
| NO. | DATE | BY | CHKD. | APP. |
| | | | | |

GIRDLER CORPORATION
 LOUISVILLE, KENTUCKY

FOR U. S. NAVY

HYDROGEN GENERATOR
 PLAN VIEW

CLASS. NO. 100
 100

EQUIPMENT LEGEND

- ① REFORMER AND HYDROGEN PURIFIER CELL UNITS
- ② METHANATOR
- ③ AQUEOUS METHANOL FEED VAPORIZER
- ④ OXYGEN VAPORIZER
- ⑤ AQUEOUS METHANOL FEED PREHEATER
- ⑥ FLUE GAS COOLER
- ⑦ SEPARATOR
- ⑧ DIRECT CONTACT COOLER SATURATOR
- ⑨ PROCESS METHANOL FEED PUMP
- ⑩ PROCESS CONDENSATE FEED PUMP
- ⑪ FUEL METHANOL PUMP
- ⑫ FUEL WATER INJECTION PUMP
- ⑬ CONDENSATE MAKE-UP PUMP

THIS DRAWING IS THE PROPERTY OF GIRDLER CORPORATION, LOUISVILLE, KENTUCKY, AND IS LENT WITHOUT CONSIDERATION OTHER THAN THE BORROWER'S AGREEMENT THAT IT SHALL NOT BE REPRODUCED, COPIED, LENT, OR USED IN ANY MANNER DIRECTLY OR INDIRECTLY FOR ANY PURPOSE OTHER THAN THAT AUTHORIZED BY THE LENDER. THIS PRINT IS LENT SUBJECT TO RETURN ON DEMAND.

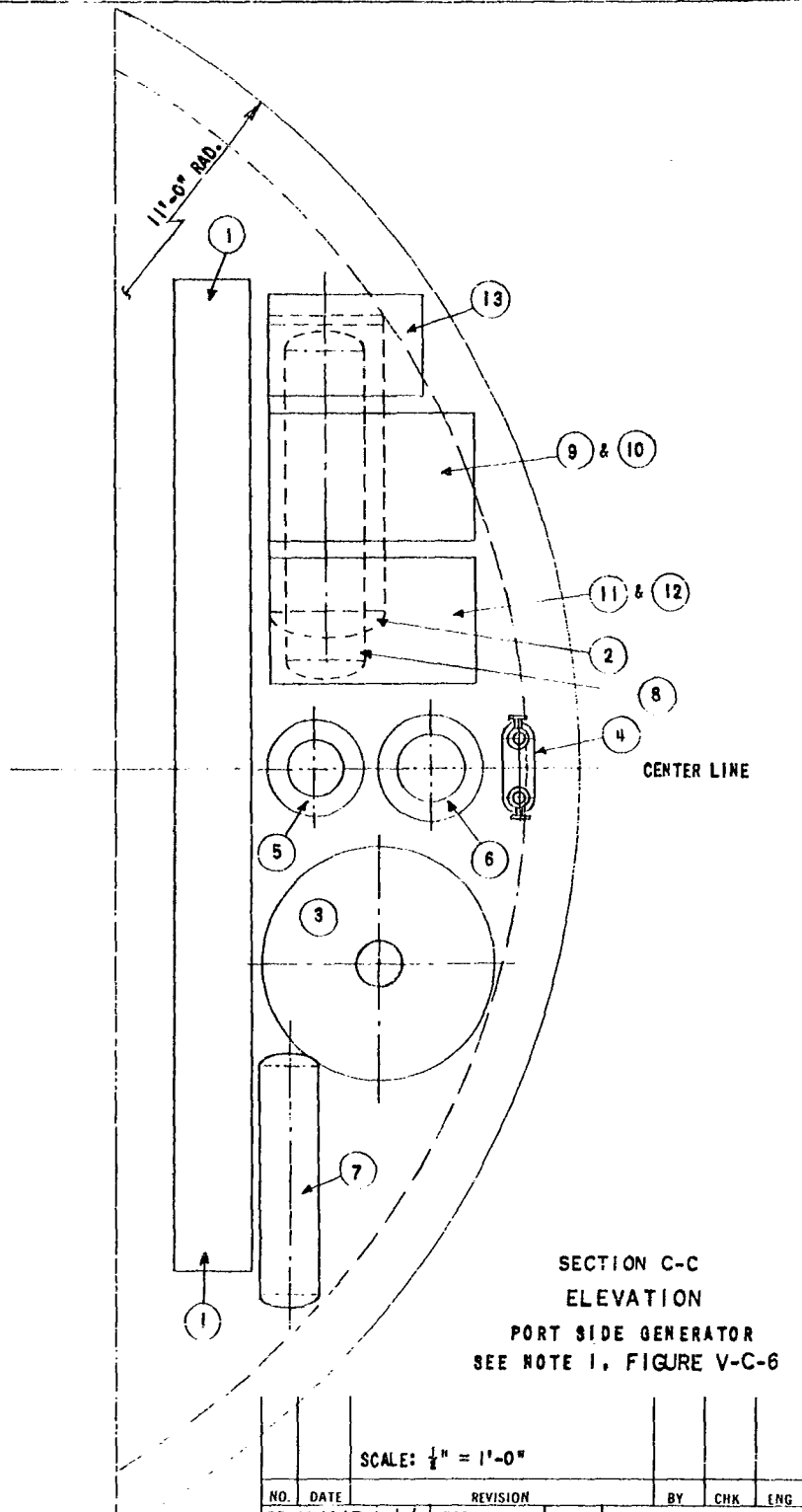

SECTION C-C
ELEVATION
PORT SIDE GENERATOR
SEE NOTE 1, FIGURE V-C-6

SCALE: 1/4" = 1'-0"

| NO. | DATE | REVISION | BY | CHK. | ENG. |
|---------|------|----------|------|------|------|
| DR. BY | MVB | 10/1/61 | HEAD | | |
| CHK. BY | | J. ENG. | | | |
| DES. BY | | | | | |

FIGURE NO. V-C-7

GC 62-11

| | | | | |
|---|-------------------|---------------------------------|-------------|------|
| GIRDLER CORPORATION LOUISVILLE, KENTUCKY | FOR U. S. NAVY | HYDROGEN GENERATOR ELEVATION | DRAWING NO. | REV. |
| | | | A-5414-2 | 0 |

PROCESS FLOW LEGEND

- ④ DRY HYDROGEN PRODUCT
- ⑤ PURGE GAS
- ⑥ OXYGEN
- ⑦ FUEL
- ⑧ FLUE GAS
- ⑨ CONDENSATE
- ⑩ SATURATED HYDROGEN PRODUCT
- CW CIRCULATING COOLING WATER

THIS DRAWING IS THE PROPERTY OF GIRDLER CORPORATION, LOUISVILLE, KENTUCKY, AND IS LENT WITHOUT CONSIDERATION OTHER THAN THE BOROHEWER'S AGREEMENT THAT IT SHALL BE REPRODUCED, COPIED, LENT, OR DISPOSED OF, DIRECTLY OR INDIRECTLY, OR USED FOR ANY PURPOSE OTHER THAN THAT FOR WHICH IT IS SPECIFICALLY FURNISHED. THIS PRINT IS LENT SUBJECT TO RETURN ON DEMAND.

EQUIPMENT LEGEND

- ① REFORMER AND HYDROGEN PURIFIER CELL UNITS
- ② METHANATOR
- ③ AQUEOUS METHANOL FEED VAPORIZER
- ④ OXYGEN VAPORIZER
- ⑤ AQUEOUS METHANOL FEED PREHEATER
- ⑥ FLUE GAS COOLER
- ⑦ SEPARATOR
- ⑧ DIRECT CONTACT COOLER SATURATOR
- ⑨ PROCESS METHANOL FEED PUMP
- ⑩ PROCESS CONDENSATE FEED PUMP
- ⑪ FUEL METHANOL PUMP
- ⑫ FUEL WATER INJECTION PUMP
- ⑬ CONDENSATE MAKE-UP PUMP

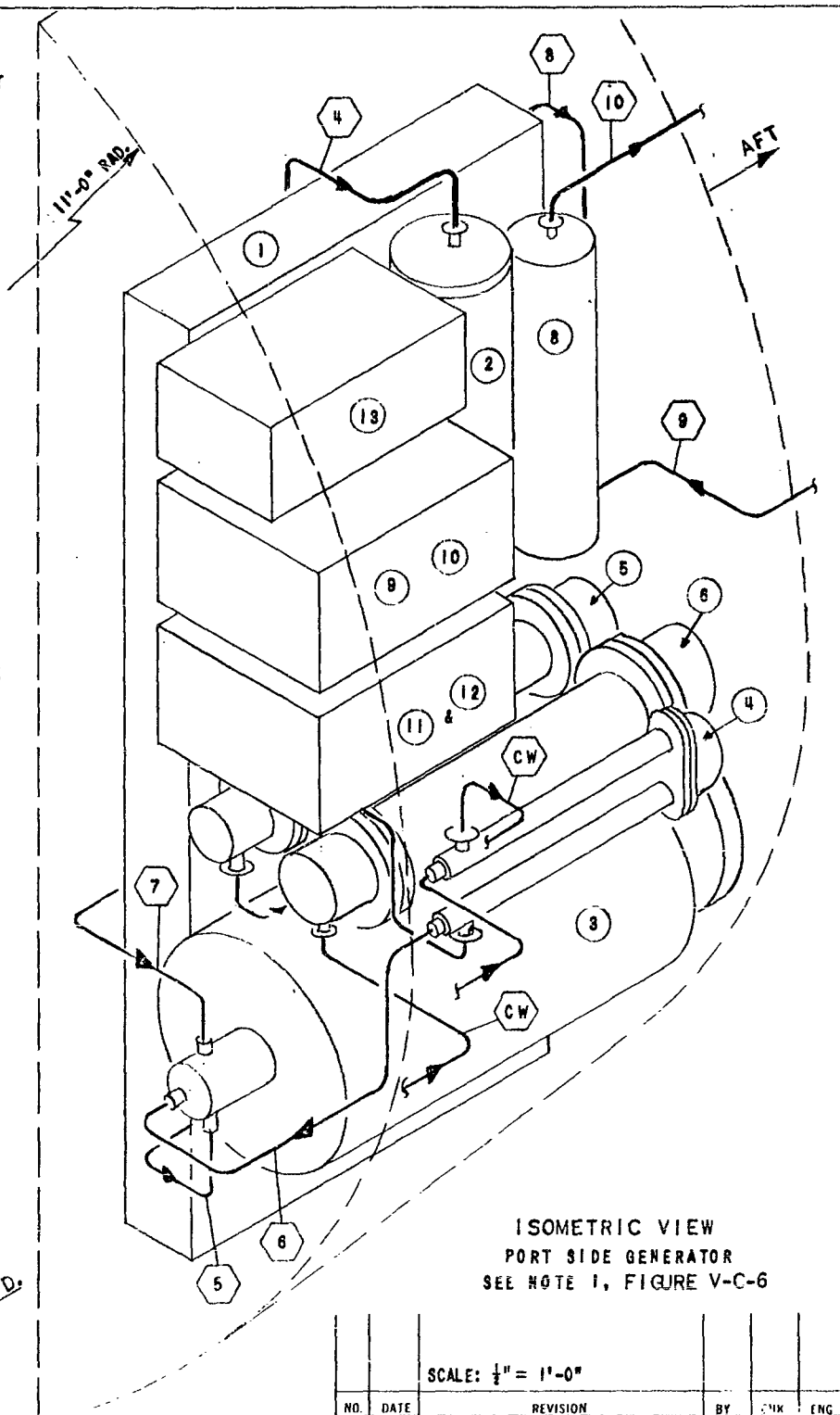

ISOMETRIC VIEW
 PORT SIDE GENERATOR
 SEE NOTE 1, FIGURE V-C-6

SCALE: 1/4" = 1'-0"

| NO. | DATE | REVISION | BY | CHK | ENG |
|---------|---------|----------|------|-----|-----|
| DR. BY | 10/2/58 | 10/2/58 | HEAD | | |
| CHK. BY | | | ENG. | | |
| DESR. | | | | | |

FIGURE NO. V-C-8

GC 62 11

GIRDLER CORPORATION
 LOUISVILLE, KENTUCKY

FOR U. S. NAVY

HYDROGEN GENERATOR
 ISOMETRIC VIEW

| | |
|-------------|------|
| DRAWING NO. | REV. |
| A-5414-3 | 0 |

VI. DISCUSSION OF CHARACTERISTICS

The process presented was designed keeping in mind the various requirements peculiar to the submarine application. The three most important factors considered were compactness, rapid response to changes in output demand, and safety. Summarized in this section is a discussion of the more important characteristics of this design and the effect of some alternatives and scale-up.

A. Physical

The detailed discussion of the process and the major pieces of equipment is contained in Section V.

1. Design Advantages

The proposed design has many advantages which make it particularly suitable for submarine application. With the exception of the feed vaporizer all of the major pieces of equipment are small enough to fit through a hatch of 25" in diameter. Thus for repair or replacement it would not be necessary to cut through the side of the ship. The one exception, the feed vaporizer, is easily constructed and could be assembled on board the submarine. The design is compact and readily adaptable to the 580 hull design. The reformer and the palladium diffusion purification cells both operate at the same temperature. Since they are both compact, they were designed to be installed within a single insulated box. This eliminates the need for refractory lining in the reformer. The reformer and palladium diffusion cells are thus more resistant to shock. Making use of a common insulated box reduces the lost space of individual insulation. The feature of high pressure reforming has the advantage that the carbon dioxide flue gas can be ejected overboard without the use of a compressor. Also, no compressor is needed to pressurize the crude hydrogen gas for purification in the palladium cells.

Elimination of a compressor removes a source of structure borne vibration which experience from Girdler built Carbon Dioxide Removal Units has shown to be quite troublesome. The only rotating components in this design are the water, methanol, and liquid oxygen pumps and motivation systems. The pumps are positive displacement. Girdler's experience with structure borne sound evaluations had shown the positive displacement pump to be troublesome. However, this problem has been successfully eliminated by the use of pulsation dampeners. No particular troubles are foreseen in accomplishing a particularly noise quiet unit.

VI. DISCUSSION OF CHARACTERISTICS - contd.

With the proposed system there are no liquid solutions, thus a reduction in contamination susceptibility. There would, likewise, be no chemicals to store. The plant design is capable of operating at steep angles and standard conditions of pitch and roll are expected to have no effect.

The instrumentation on this design is quite complete making the unit fully automatic and lends itself to computer control for advantageous response characteristics. The rapid response characteristics are accomplished by the unique injection of additional oxygen into the reaction zone of the reactor. Because of the high degree of instrumentation the design is considered quite safe. The hydrogen inventory has likewise been held to a minimum, less than 50 SCF.

The maintenance is expected to be at a minimum because no corrosive solutions or chemicals are being encountered. There are no extraneous materials generated which could contaminate the submarine atmosphere.

2. Desirable Alternatives

The proposed design is highly sophisticated and efficient. The system makes efficient use of all the waste heat at the expense of more equipment and instrumentation. A more simple design could be made. It would be less efficient and would require 10-15% more methanol but very little additional oxygen consumption. It would have a direct fired vaporizer and preheater with firing at atmospheric pressure. The carbon dioxide would then have to be compressed for ejection overboard. The off-gas from the palladium diffuser cells, containing small amounts of carbon monoxide and methane under pressure, would be ejected overboard without firing. A design of this type would require much less instrumentation, thus a more compact design. It could also be computer controlled for a minimum of attention. The difficulty of firing the vaporizer under pressure would be eliminated. Operation on air would be less difficult because there would be no necessity for compressing the air needed for combustion.

An alternative to the above designs can be made. Diesel fuel can be substituted for methanol for firing the vaporizer. This would result in use of a fuel having a

VI. DISCUSSION OF CHARACTERISTICS - contd.

higher heating value with less fuel being required. This diesel fuel firing can be accomplished because the flue gas does not enter the reformer or the palladium diffuser cells. Diesel fuel firing could not be tolerated without special treating if the flue gas goes to the palladium cells as there may be palladium poisons in the oil. Some greater difficulty may be encountered in the firing of diesel fuel under pressure than with methanol.

It may develop that from a detection point of view it would be undesirable to eject the carbon dioxide directly overboard. If that should be the case, the proposed design could be slightly altered. Because the carbon dioxide is under pressure, it could be further dried and then liquified by cryogenic cooling with liquid oxygen. The liquid carbon dioxide could be easily stored in tanks and pumped overboard at a convenient time.

3. Scale-up

The design of this plant is readily adaptable to scale-up. No great problems with respect to process are anticipated. The same general flow scheme would be used.

Generally speaking the size of the equipment would be directly related to the scale-up desired. For instance, to scale-up from 70 lbs/hr. to 350 lbs/hr. would require 40 reformer tubes instead of the present 8 tubes and the methanator volume would increase from 4.45 ft.³ to 22.15 ft.³. If the larger sized unit is undesirable then multiple trains of equipment can be used. The larger sized plant would not be adaptable to the spacing allotment for the 580 hull design but could quite readily be adapted to a new submarine design.

B. Operating

1. Startup

Initially there are two pre-startup functions which can be performed in port. These are activation of the palladium silver alloy and activation of the methanation

VI. DISCUSSION OF CHARACTERISTICS -- contd.

catalyst, if required. The palladium is activated by evacuating both sides of the cell down to an absolute pressure of 1 - 2 mm of Hg, bleeding in air to atmospheric pressure and re-evacuating. The above procedure is carried out while the cells are heated to 800°F. by hot flue gases flowing through the reformer tubes which are insulated together with the hydrogen purifier cells. The palladium should not require regeneration unless mis-operation of the reforming step produces carbon and/or olefins which will temporarily poison the palladium. This step could be performed at sea by the addition of a vacuum pump.

Activation of the methanation catalyst is carried out by reducing it with hydrogen at 750°F. for about six hours. The flow of hydrogen can be obtained from cylinders with preheating to 750°F. in the reformer or methanol can be reformed in the hydrogen generator to produce the required hydrogen flow. This step can also be performed at sea if required.

Also, before insulation is applied, the hydrogen generator should be tested for leaks. Before each startup the hydrogen purifier cells should be checked for leaks by applying nitrogen to the high pressure side and noting any pressure rise on the low pressure side.

On startup the submarine should be vented to the surface in order that the burner can be lighted off at atmospheric pressure. Condensate is pumped at a low rate through the vaporizer and vented to the atmosphere to prevent overheating of the vaporizer coil and to control the temperature of the flue gases to the reformer.

The burner is started up on a methanol-water mixture and oxygen. It is ignited at atmospheric pressure by means of a lance inserted through a hand hole which is flanged up after light off. Cooling water flow is established through the flue gas cooler and oxygen vaporizer before light-off since cooling water is used to vaporize the oxygen.

After the hot flue gases have raised the reformer tubes and palladium diffusion cells up to operating temperature, the process methanol feed is started.

After flow is established through the unit, the pressure on the process side is increased slowly from atmospheric to 200 psig. During this period the purge gas is vented rather than being burned in the vaporizer for heat recovery since there would be excessive hydrogen in the

VI. DISCUSSION OF CHARACTERISTICS - contd.

purge gas for heat balance. At this pressure sufficient hydrogen will be diffusing through the palladium so that the purge gases can be burned. After purge gas burning has been established, the pressure on the flue gas side is increased until the normal operating pressure of 350 psig is reached. As the process pressure and the flue gas pressure are increased, the process flow and fuel firing may be increased up to the desired flow rate.

During start-up it will be necessary to withdraw all of the condensate from storage until the flue gas system is under normal operating pressure of 350 psig. At this time, the condensate make-up pump is started and flow established to the flue gas system. The condensate supply is then switched from storage to the separator where condensate condensed from the flue gases is stored.

The hot low pressure hydrogen is cooled and saturated in the direct contact cooler. Condensate is made up automatically by level control. The saturated hydrogen then flows to the fuel cell.

After the system is operating under full pressure, the control of production rate or flow rate can be transferred to the computer control center.

2. Normal Operation

During normal operation, the flow rates of process raw materials, fuel and oxygen are controlled from the computer control center. They are such as to exactly balance the hydrogen demand of the fuel cells. The inlet and exit temperatures of the methanator will be constant unless there is a leak in the palladium tubing. In this case the exit temperature will increase about 140°F. for each one per cent of carbon oxides leakage. The injection of oxygen directly into the process gas leaving the vaporizer is not used under steady state conditions. The reformer exit temperature controls the fuel methanol flow rate. If the temperature of the flue gases to the reformer is too high, the ratio of fuel injection water to fuel is increased. The flow of oxygen is controlled by the analysis of the flue gases for oxygen and CO plus the speed of the fuel methanol-injection water pump.

If a small change in hydrogen demand is signaled from the submarine command to the computer control center,

VI. DISCUSSION OF CHARACTERISTICS - contd.

the computer will reset all flow rates simultaneously eliminating the normal instrumentation lag between the increase in process feed and the increase in fuel and oxygen. However, if a large change in flow rate is required such that a large change in heat transfer rate is required in the vaporizer, the computer will reset all flow rates accordingly. In addition it will over-ride the oxygen pump speed so that oxygen is available for direct injection into the process line from the vaporizer to the reformer, to maintain the reformer exit temperature at the desired temperature while the refractory in the vaporizer is heating up to the temperature required for the higher heat transfer rate. The injection of oxygen into the process gas is transient and is discontinued as soon as the normal firing methods catch up with the higher hydrogen production rate.

If a large decrease in hydrogen production is signaled the process methanol rate is decreased at constant condensate rate until the refractory in the vaporizer has cooled down to the new temperature level and the hot piping in the reformer cooled down. At this time the process methanol-water ratio is returned to normal.

If no hydrogen is required, the hydrogen generator is kept at operating temperature by burning fuel methanol to keep the equipment hot. Sufficient process condensate must be pumped through the vaporizer to prevent overheating at minimum burner turndown. The steam passing through the process side of the reformer and hydrogen purifier must be discharged downstream of the vaporizer to prevent quenching of the burner flame. The steam is condensed in the flue gas cooler and recycled to the condensate pumps.

3. Shut-down

If the hydrogen generator is to be shut down for a short period, the flow of process methanol is shut off. The flow of process condensate is continued until the steam has displaced all the hydrogen containing process gas from the high pressure side of the system. The oxygen pump, fuel methanol pump and water injection pump can then be shut off. This can be carried out in the sub-merged position. However, the reduction of pressure on the system and the final venting of flue gases cannot

VI. DISCUSSION OF CHARACTERISTICS - contd.

be done until the submarine is vented to the surface. The low pressure side of the palladium diffuser, the methanator and direct cooler-saturator can be boxed in full of hydrogen ready for the next startup since the quantity of hydrogen contained in these units at atmospheric pressure is quite small.

If the shutdown is to be of extended duration, the low pressure hydrogen can be purged out with nitrogen. If this is done, this system will have to be evacuated before the next startup for normal operation. However by tolerating impure hydrogen to the fuel cell for a short period of time on the next startup the need for evacuation could be avoided.

The high pressure oxygen in the piping can be retained in the piping or vented to the submarine atmosphere.

4. Power Consumption at Various Rates

Since all pump drivers are of the variable speed type, little power is saved at reduced rates if speed variation is accomplished by the various methods such as magnetic clutch, electronic control or D.C. series motor. Since the power consumption is so small, this item is of little consequence. Other types of drive using belts and planetary gears use less power at reduced speeds but are more subject to slippage and wear and in addition considerably more noisy in operation.

5. Response Time

The overall response time of the hydrogen generator can best be understood by analyzing the response time of each section of the unit. The purification section which consists of the palladium diffuser, methanator, and cooler-saturator is essentially instantaneous in response provided the system is maintained at operating conditions and can be supplied with the required crude hydrogen feed. It can be turned on, turned off or changed in flow rate as rapidly as a water faucet. However, it is more difficult for the generating section to supply the crude hydrogen with this facility. In this section, the response of the heat transfer equipment is limiting. The refractory mass in the vaporizer although small requires some finite time to change to a new temperature level. The refractory should be light weight and have low heat storage characteristics. There

VI. DISCUSSION OF CHARACTERISTICS - contd.

is also a small inherent lag in any heat recovery system such as is used in this generation section where the process feed is preheated with flue gas of which about 50% is supplied by the burning of the purge gases. It is these two lag times mentioned above that the direct injection of oxygen into the process feed stream is proposed to eliminate or reduce to a minimum.

Experience on other units of this type would indicate a start-up from a cold unit to normal operating rate might require about 30 minutes. Shutting down the unit would be essentially instantaneous. Response time from minimum operating rate to maximum operating rate would be in the order of a few minutes. Response time from normal operating rate to maximum operating rate would be essentially instantaneous with the use of the oxygen assist feature of the design.

6. On Stream Factor

The unit has been designed to easily meet the requirement of 10 days continuous operation. Most of this operation would be at the normal rate with 10 hours at the maximum rate in two hour periods. However, it is believed that the equipment is designed to operate considerably longer than this without maintenance. Experience indicates that catalyst life expectancy can be considerably greater than the 10 days specified. For long periods of operation allowance may be required to allow for changing catalysts characteristics.

C. General

1. Fuel

Methanol as a process or combustion fuel for hydrogen generation on board submarines has many advantages over other materials such as jet fuel, diesel oil, or ammonia. Methanol is a relatively pure chemical, 99.85% in commercial quantities. It is widely available and easily stored and handled. Being of high purity, methanol does not give rise to undesirable by-products which would result in difficult disposal problems on submarines. Methanol does not contain sulfur, a catalyst poison, which may be present in some petroleum fuels. There are no large quantities of nitrogen to be disposed of by liquefaction or some other more difficult means, as would be the case with ammonia decomposition.

VI. DISCUSSION OF CHARACTERISTICS - contd.

There is reason to believe that ethanol could be substituted for methanol. This could be the commercial azeotrope ethanol-water mixture. For the fuel side of the process other materials could be substituted for the methanol if certain design provisions are made while still maintaining the process advantages of methanol as a process feed.

2. Disposal of Waste Gases

In the proposed design, essentially all of the carbon in both the process feed methanol and fuel methanol leave the generator in the form of carbon dioxide at 350 psig, 200°F. and saturated with water vapor. Also present is the argon contained in the oxygen and probably a small quantity of unreacted oxygen and carbon monoxide which generally results even from combustion at stoichiometric ratios of fuel and oxygen. Under these conditions, there is sufficient pressure for the carbon dioxide to be released overboard while submerged. The present design incorporates this technique. If this procedure is not desirable from the standpoints of noise and surface detection, the carbon dioxide can be liquefied by the evaporation of liquid oxygen flowing to the fuel cell and to the hydrogen generator. It can be purged overboard from the submarine continuously mixed in with the sea water cooling system; or if necessary, it can be stored as a liquid and discharged periodically at convenient times. The main point is that the carbon dioxide is under sufficient pressure to liquefy at a sufficiently high pressure and temperature that dry ice is not formed. It would be necessary to dry the carbon dioxide before liquefying if this route is chosen.

3. Air Operation

If air is available from the surface, the hydrogen generator can be run at various rates depending on the pressure at which air is supplied to the burner. If it can be compressed to 450 psig elsewhere on the submarine, the hydrogen generator can run at full rate. Approximately 66 KW would be required to operate the air compressor at the 70 lbs/hr. or maximum hydrogen rate. The combustion volume in the aqueous methanol feed vaporizer is sufficient to allow operation at a 30 lbs/hr. hydrogen rate at atmospheric pressure. However, operation at atmospheric pressure is not practical since there must be sufficient pressure on the flue gases to overcome the pressure drop through the reformer and other heat recovery

VI. DISCUSSION OF CHARACTERISTICS - contd.

equipment. If considerable operating time on air is contemplated, furnace operation at a substantially lower pressure with compression of the carbon dioxide from the submarine when it is submerged may be more economical overall than the present design.

In order to switch from oxygen operation to air operation, the burner may have to be changed depending on the maximum hydrogen rate required when on air generation. It will definitely require changing if low pressure air is used in one case and high pressure oxygen in the other case.

VII. DISCUSSION OF DESIGN VERIFICATION- contd.

In the preliminary study and the preparation of the final process and mechanical design of a prototype unit, a number of problems were encountered. The solution to some of these were readily obtained after investigation and evaluation of the factors involved. In some instances alternate solutions were apparent. When these occurred a weighted choice was made between the certainty of present knowledge and the advantages that might be gained in this particular application. In other instances a degree of uncertainty necessitated assumptions which will require experimental verification.

A. Process

In general the process steps chosen have all been carried out in one form or another in Girdler's laboratories, pilot plants or commercial plants. These include such steps as the following:

1. Pumping and vaporizing methanol, condensate and liquid oxygen.
2. Burner operation under pressure on oxygen tempered with condensate and combustibles such as methanol and hydrogen containing purge gas.
3. Catalytic reforming of methanol with steam at 600 to 800°F. with oxygen injection.
4. Purification of crude gas by palladium diffusion.
5. Methanation of residual carbon oxide to protect fuel cell from contaminants in case of minor leaks.
6. Cooling and saturation of product hydrogen.

However, conditions used in the process design give rise to uncertainties concerning reaction rates, selectivity and thermodynamic equilibrium. These further are associated mainly with the catalyst which might be considered the very heart of the process. A great deal of catalytic data has been developed in Girdler laboratories on the reactions. However, the actual performance of the catalyst in the proposed unit and specifically under the conditions used, requires experimental verification. Actual factors to be developed experimentally include the following:

1. Selectivity of the catalyst for suppressing methane formation: Since there is a large thermodynamic potential

VII. DISCUSSION OF DESIGN VERIFICATION - contd.

for this reaction a large amount of methane could theoretically be formed. An appreciable amount could be tolerated in the crude product, since the purge gas is used as fuel. In this design, methane in the crude gas was assumed to be 1% by volume since catalyst data indicates that the desired selectivity can be obtained.

2. The degree of conversion of methanol at the chosen conditions: Indications are that high catalyst activity can be obtained. An approach of 100°F. to thermodynamic equilibrium was used in the design.

3. The activity of the catalyst for the water gas shift reaction: Data appear to show that carbon monoxide will approach the equilibrium value over most catalyst that are active for the methanol reforming reaction. An approach of 100°F. to thermodynamic equilibrium was used in the design. Palladium will catalyze the reaction so that further conversion of the CO will be obtained in the diffuser. No credit has been taken for this in the design.

4. Suppression of other undesirable side reactions: The generation of various organic products and the formation of carbon are mainly suppressed by the use of a selective catalyst. A sufficient steam to methanol ratio is important for suppressing these reactions as well as for controlling the final equilibrium of the $H_2-H_2O-CO-CO_2$ constituents. Excessive steam results in larger equipment and loss in efficiency. A steam to methanol mol ratio of 2 to 1 was chosen as being reasonable with some reduction possible by experimental verification.

5. Heat loss from the unit: The heat loss from equipment of this kind is subject to fairly precise calculation. However, because of the nature of the space requirements and unusual equipment configurations, calculations become somewhat uncertain. Past experience with similar units resulted in the use of a value of 60,000 BTU/hr. which is believed to be conservative, allowing some flexibility for balancing space for insulation against overall efficiency.

6. Effect of poisons on palladium diffuser: Certain constituents are known to be poisonous to the palladium silver alloy surface. Most of these are temporary although inorganic salts or metals could adversely and permanently affect the performance of a palladium diffuser. With the proposed feed no poisoning is expected from the material being processed. Other than the hydrogen the constituents

VII. DISCUSSION OF DESIGN VERIFICATION - contd.

in the crude reformed product will be essentially inert. Catalysis of the CO-H₂O reaction is expected but should not have any adverse effects. Methanol is not reported to be a poison and tests in Girdler's laboratory appear to confirm this so that unconverted methanol in the crude hydrogen to the diffuser is assumed to be harmless.

7. Reformer heat flux: To determine the number of catalyst tubes, the heat flux had to be chosen based on past experience. The ultimate capacity of any configuration is related to the catalyst activity as well as the allowable heat flux. The effect of temperature gradient on catalyst life and activity will be the main factor in determining the ultimate capacity of the unit. Experimental evaluation is required to establish this point.

8. Catalyst life: In addition to the factors mentioned above, the catalyst life must be determined experimentally with relation to production rates and operating conditions.

9. Oxygen reactant: In order to improve the response time of the hydrogen generation, oxygen injection directly into the reactants is used. The reforming reaction as carried out over a special catalyst at temperatures of 600° - 800°F. but the activity of these catalyst for the oxidation reaction must be established. The alternative is to use a two bed reactor with separate catalysts to promote the two reactions. This is known to be feasible but requires experimental verification to ensure the success of the oxygen injection feature.

B. Equipment

1. Moving equipment and noise generation: Ultimately, after the construction of a prototype unit, the equipment will require a severe test for reliability. Items involving moving parts such as pumps and valves will require close evaluation. It is felt that these items are fairly predictable especially if proper control of specifications and inspection is exercised. However, noise factors must be determined in the final unit although experience with similar units indicate the problem of minimizing the noise is not insurmountable.

VII. DISCUSSION OF DESIGN VERIFICATION -- contd.

2. High pressure burner: Experience with pressure burners indicates that some improvement is desirable particularly with respect to life of burner tips. However, in this respect it may be that a solution involving multiple burners or mechanical ease of replacement can be developed after some experimental testing.

3. Pressure drop limitation of palladium diffuser: Commercial experience with palladium diffusers has been limited to pressure differentials across the palladium alloy tubes of less than 300 psi. Experimental work at high pressure differentials indicate some uncertainty because of tolerance variation with commercially available palladium alloy tubes. Indications are that this problem can be handled by internally supporting the capillary walls with a porous inert material.

C. Instrumentation

The design of the unit has been predicated on fully automatic operation with no operator attention except in the case of startup, shutdown or abnormal conditions. For static conditions at some predetermined production rate the control system is predictable and no unusual problems are expected.

Rapid rate change is one of the requirements of the unit. Conventional methods of sensing control points, adjusting flows and pressure levels and normal controller anticipatory ability can be used. However, it is proposed to make use of computer control to augment the anticipatory function as well as to analyze performance and modify the program as required during the life of a run. By this means the response can be increased many fold and peak performance ensured at all times.

For computer control a digital machine is required and is assumed to be part of the submarine control system. If this should not be available an analog system could be used.

In order to obtain the optimum design for this type control, the construction and operation of a prototype unit is essential. The basic items to be studied would be the dynamic characteristics of the system and the effect of logged time on the characteristics. Another related item would be the optimization of the oxygen injection system.

VII. DISCUSSION OF DESIGN VERIFICATION - contd.

D. Experimental Plan

From the above discussion it is apparent that uncertainties that require experimental verification fall into two categories. The first group involving a number of process problems can best be studied in a bench scale or small pilot plant set-up. The second group involving equipment and control problems can best be studied in a prototype unit.

Three approaches are possible to the experimental program:

1. Carry out bench scale program before proceeding to the prototype unit.
2. Carry out bench scale program and prototype program simultaneously.
3. Carry out all experimental studies on prototype unit.

Either (1) or (2) are rational approaches to the experimental program with (1) being preferred unless time schedules are overriding. The third is the least desirable because of the difficulty of physically carrying out the required studies on the highly engineered prototype plant.

VIII. APPENDIX

| | | | | | |
|--------------------------------------|---|---------------------------------|-----------------------|-----------------------------------|-----------------------------------|
| GIRDLER CORPORATION | | | | SUPPLIER | |
| LOUISVILLE, KENTUCKY | | | | SHOP LOCATION | |
| | | | | DATE | REF. |
| EXCHANGER SPECIFICATION SHEET | | | | | |
| | | | | No. 5414-E-1 | |
| 1 | CUSTOMER | U. S. Navy | | GIRDLER JOB NO. | 131-5414 |
| 2 | ADDRESS | | | CUSTOMER'S REF. NO. | NOBS 86743 |
| 3 | PLANT LOCATION | | | ENG'R | MWO CHECK DATE 9/27/62 |
| 4 | NAME OF UNIT | Methanol Feed Preheater | | REVISION | <input type="checkbox"/> LINE |
| 5 | NO. OF UNITS REQ'D. | 1 | ITEM NO. | E-1 | <input type="checkbox"/> LINE |
| 6 | SIZE | | | TYPE | BES <input type="checkbox"/> LINE |
| 7 | SURFACE PER UNIT | 18 | PER SHELL | 18 | SHELLS PER UNIT CONNECTED IN |
| PERFORMANCE OF ONE UNIT | | | | | |
| | | SHELL SIDE | | TUBE SIDE | |
| 8 | FLUID CIRCULATED | Flue Gas | | Condensate & methanol | |
| 9 | TOTAL FLUID ENTERING | mol/hr. 56.75 | | 42.54 | |
| 10 | VAPOR | | | | |
| 11 | LIQUID | mol/hr. | | 42.54 | |
| 12 | STEAM | mol/hr. 39.79 | | | |
| 13 | NON-CONDENSABLES | mol/hr. CO ₂ = 16.96 | | | |
| 14 | FLUID VAPORIZED OR CONDENSED | | | | |
| 15 | STEAM CONDENSED | | | | |
| 16 | GRAVITY - LIQUID | | | | |
| 17 | VISCOSITY - LIQUID | | | | |
| 18 | MOLECULAR WEIGHT - VAPORS | | | | |
| 19 | SPECIFIC HEAT - LIQUIDS | | | B.T.U./# | |
| 20 | LATENT HEAT - VAPORS | | | B.T.U./# | |
| 21 | TEMPERATURE IN / OUT | 800 / 450 °F | | 150 / 350 °F | |
| 22 | OPERATING PRESSURE, INLET | 360 #/SQ. IN. | | 450 #/SQ. IN. | |
| 23 | NUMBER OF PASSES | 1 | | Multi | |
| 24 | VELOCITY | | | FT./SEC. | |
| 25 | PRESSURE DROP | | | #/SQ. IN. | |
| 26 | FOULING RESISTANCE | 0.002 SQ. FT. HR. °F/BTU | | 0.001 SQ. FT. HR. °F/BTU | |
| 27 | HEAT EXCHANGED - B.T.U./HR. | 177,000 | | M.T.D. (CORRECTED) | |
| 28 | TRANSFER RATE - SERVICE | | | CLEAN | |
| CONSTRUCTION | | | | | |
| 29 | DESIGN PRESSURE | 400 #/SQ. IN. | | 500 #/SQ. IN. | |
| 30 | TEST PRESSURE | Per code #/SQ. IN. | | Per code #/SQ. IN. | |
| 31 | DESIGN TEMPERATURE | 850 °F | | 500 °F | |
| 32 | CONFINED GASKETS REQ'D | Yes | | Yes | |
| 33 | CORROSION ALLOWANCE | None | | None | |
| 34 | CONNECTIONS - IN / OUT | | | | |
| 35 | TUBES | A213 tp 304 | No. o.d. 3/4" BWG. 16 | LENGTH 4' | PITCH 15/16" LAYOUT tri |
| 36 | SHELL | A240 tp 304 | I.D. O.D. | THK. | OVERALL UNIT LENGTH |
| 37 | SHELL COVER | A240 tp 304 | | FLOATING HEAD COVER A240 tp 304 | |
| 38 | CHANNEL | A240 tp 304 | | CHANNEL COVER Integral bonnet | |
| 39 | TUBE SHEETS - STATIONARY | A240 tp 304 | | FLOATING A240 tp 304 | |
| 40 | BAFFLES - CROSS | A240 tp 304 | | SPACING | THK. TYPE |
| 41 | BAFFLE - LONG | | TYPE THK. | TUBE SUPPORTS THK. | |
| 42 | GASKETS, CHANNEL | S.S. jack. asb. | | BOLTS, INTERNAL A193 - B8 | |
| 43 | GASKETS, FLT. HEAD | S.S. jack. asb. | | BOLTS, EXTERNAL A193 - B7 | |
| 44 | GASKETS, SHELL | S.S. jack. asb. | | TIERODS 304 S.S. | |
| 45 | CODE REQUIREMENTS | 1962 ASME | STAMP Yes | SPEC. Girdler ED-E1 & TEMA "C"(1) | |
| 46 | WEIGHTS - EACH SHELL | BUNDLE | | FULL OF WATER | |
| 47 | OUTLINE DRWG. NO. | | | GASKET DRWG. NOS. | |
| 48 | NOTE: INDICATE AFTER EACH PART WHETHER STRESS RELIEVED (S.R.) AND WHETHER RADIOGRAPHED (X.R.) | | | | |
| 49 | REMARKS:-- (1) Also Navy shockproof equip. spec. MIL-S-901B (NAVY) dated 4/9/54 applies. | | | | |
| 50 | | | | | |
| 51 | | | | | |
| 52 | | | | | |

GIRDLER CORPORATION

LOUISVILLE, KENTUCKY

SUPPLIER

SHOP LOCATION

DATE

REF.

EXCHANGER SPECIFICATION SHEET

NO. 5414-E-2

CUSTOMER U. S. Navy

GIRDLER JOB NO. 131-5414

ADDRESS

CUSTOMER'S REF. NO. NOBS 86743

PLANT LOCATION

ENG'R MWO CHECK

DATE 9/27/62

NAME OF UNIT Flue Gas Cooler

| | | |
|--------------------------|------|-----|
| <input type="checkbox"/> | LINE | 1/1 |
| <input type="checkbox"/> | LINE | 1/1 |
| <input type="checkbox"/> | LINE | 1/1 |

NO. OF UNITS REQ'D. 1 ITEM NO. E-2

SIZE TYPE BES

SURFACE PER UNIT 44 PER SHELL 44 SHELLS PER UNIT 1 CONNECTED IN

PERFORMANCE OF ONE UNIT

| | SHELL SIDE | | TUBE SIDE | |
|--------------------------------------|--------------------------|--------------------|--------------------|--------------------|
| FLUID CIRCULATED | Flue gas | | Cooling water | |
| TOTAL FLUID ENTERING Mol/hr. | 56.75 | | 2,445 | |
| VAPOR | | | | |
| LIQUID | | | | |
| STEAM Mol/hr. | 39.79 | | | |
| NON-CONDENSABLES Mol/hr. | CO ₂ = 16.96; | | | |
| FLUID VAPORIZED OR CONDENSED Mol/hr. | 39.21 | | | |
| STEAM CONDENSED | | | | |
| GRAVITY - LIQUID | | | | |
| VISCOSITY - LIQUID | | | | |
| MOLECULAR WEIGHT - VAPORS | | | | |
| SPECIFIC HEAT - LIQUIDS | | | B.T.U./# | B.T.U./# |
| LATENT HEAT - VAPORS | | | B.T.U./# | B.T.U./# |
| TEMPERATURE IN / OUT | 450 | / 200 °F | 95 | / 115 °F |
| OPERATING PRESSURE, INLET | 355 #/SQ. IN. | | 50 #/SQ. IN. | |
| NUMBER OF PASSES | 1 | | Multi | |
| VELOCITY | | | FT./SEC. | FT./SEC. |
| PRESSURE DROP | | | #/SQ. IN. | #/SQ. IN. |
| FOULING RESISTANCE | 0.002 | SQ. FT. HR. °F/BTU | 0.001 | SQ. FT. HR. °F/BTU |
| HEAT EXCHANGED - B.T.U./HR. | 882,078 | | M.T.D. (CORRECTED) | |
| TRANSFER RATE - SERVICE | | | CLEAN | |

CONSTRUCTION

| | | |
|--|---------------------------------|-----------------------------------|
| DESIGN PRESSURE | 400 #/SQ. IN. | 75 #/SQ. IN. |
| TEST PRESSURE | Per Code #/SQ. IN. | Per Code #/SQ. IN. |
| DESIGN TEMPERATURE | 600 °F | 400 °F |
| CONFINED GASKETS REQ'D? | Yes | Yes |
| CORROSION ALLOWANCE | None | None |
| CONNECTIONS - IN / OUT | / | / |
| TUBES A213 tp 304 No. 3/4" O.D. 3/4" BWG. 16 | LENGTH 4' | PITCH 15/16" LAYOUT tri. |
| SHELL A240 tp 304 I.D. O.D. | THK. | OVERALL UNIT LENGTH |
| SHELL COVER A240 tp 304 | FLOATING HEAD COVER A240 tp 304 | |
| CHANNEL A240 tp 304 | CHANNEL COVER Integral bonnet | |
| TUBE SHEETS - STATIONARY A240 tp 304 | FLOATING A240 tp 304 | |
| BAFFLES - CROSS A240 tp 304 | SPACING | THK. TYPE |
| BAFFLE - LONG | TYPE | THK. TUBE SUPPORTS |
| GASKETS, CHANNEL S.S. jack. asb. | BOLTS, INTERNAL A193 B8 | |
| GASKETS, FLT. HEAD S.S. jack. asb. | BOLTS, EXTERNAL A193 B7 | |
| GASKETS, SHELL S.S. jack. asb. | TIERODS 304 S.S. | |
| CODE REQUIREMENTS 1962 ASME | STAMP Yes | SPEC. Girdler ED-E1 & TEMA "C"(1) |
| WEIGHTS - EACH SHELL | BUNDLE | FULL OF WATER |
| OUTLINE DRWG. NO. | GASKET DRWG. NOS. | |

NOTE: INDICATE AFTER EACH PART WHETHER STRESS RELIEVED (S.R.) AND WHETHER RADIOGRAPHED (X.R.)

REMARKS: (1) Navy shockproof equip. spec. MIL-S-901B(NAVY) dated 4/9/54 applies.

GIRDLER CORPORATION
LOUISVILLE, KENTUCKY

SUPPLIER _____
SHOP LOCATION _____
DATE _____ REF. _____

EXCHANGER SPECIFICATION SHEET

NO. 5414-E-3

1 CUSTOMER U. S. Navy GIRDLER JOB NO. 131-5414
2 ADDRESS _____ CUSTOMER'S REF. NO. NOBS 86743
3 PLANT LOCATION _____ ENG'R MWO CHECK DATE 9/27/62
4 NAME OF UNIT Oxygen vaporizer
5 NO. OF UNITS REQ'D. _____ ITEM NO. E-3
6 SIZE _____ TYPE Double Pipe "U"
7 SURFACE PER UNIT 3 PER SHELL 3 SHELLS PER UNIT 1 CONNECTED IN _____

PERFORMANCE OF ONE UNIT

| | SHELL SIDE | TUBE SIDE |
|---------------------------------|--------------------------|--------------------------|
| 8 FLUID CIRCULATED | Liquid oxygen | Water |
| 9 TOTAL FLUID ENTERING | 7.94 mol/hr | 88 gpm (1) |
| 10 VAPOR | | |
| 11 LIQUID | 7.94 mol/hr | 88 gpm |
| 12 STEAM | | |
| 13 NON-CONDENSABLES | | |
| 14 FLUID VAPORIZED OR CONDENSED | 7.94 mol/hr | |
| 15 STEAM CONDENSED | | |
| 16 GRAVITY - LIQUID | | |
| 17 VISCOSITY - LIQUID | | |
| 18 MOLECULAR WEIGHT - VAPORS | | |
| 19 SPECIFIC HEAT - LIQUIDS | B.T.U./# | B.T.U./# |
| 20 LATENT HEAT - VAPORS | B.T.U./# | B.T.U./# |
| 21 TEMPERATURE IN / OUT | -297 / 60 °F | 115 / 114 °F |
| 22 OPERATING PRESSURE, INLET | 450 #/SQ. IN. | 50 #/SQ. IN. |
| 23 NUMBER OF PASSES | 1 | 1 |
| 24 VELOCITY | FT./SEC. | FT./SEC. |
| 25 PRESSURE DROP | #/SQ. IN. | #/SQ. IN. |
| 26 FOULING RESISTANCE | 0.001 SQ. FT. HR. °F/BTU | 0.001 SQ. FT. HR. °F/BTU |
| 27 HEAT EXCHANGED - B.T.U./HR. | 42,400 | M.T.D. (CORRECTED) |
| 28 TRANSFER RATE - SERVICE | | CLEAN |

CONSTRUCTION

| | | |
|--|-------------------------|------------------------------------|
| 29 DESIGN PRESSURE | 500 #/SQ. IN. | 75 #/SQ. IN. |
| 30 TEST PRESSURE | Per code #/SQ. IN. | Per code #/SQ. IN. |
| 31 DESIGN TEMPERATURE | -307 to 150° °F | -307 to 150 °F |
| 32 GASKETED GASKETS REQ'D? | | |
| 33 CORROSION ALLOWANCE | 1/16" | 1/16" |
| 34 CONNECTIONS - IN / OUT | 1" 300# RF / 1" 300# RF | 1-1/2" 150# RF / 1-1/2" 150# RF |
| 35 TUBES SA 312 tp 304 (2) No. 1" U o.d. 1.9" RW. Sch 40 | LENGTH | PITCH LAYOUT (3) |
| 36 SHELL SA 312 tp 304 (2) o.d. 3.5" "U" | THICKNESS Sch 40 | OVERALL UNIT LENGTH 3'-6" |
| 37 SHELL COVER | | FLOATING HEAD COVER |
| 38 CHANNEL | | CHANNEL COVER |
| 39 TUBE BELLS - STATIONARY | | FLOATING |
| 40 TUBES - CROSS | | SPACING THK. TYPE |
| 41 TUBES - LONG | TYPE THK. | TUBE SUPPORTS THK. |
| 42 GASKETS, CHANNEL | None | BOLTS, INTERNAL |
| 43 GASKETS, FLT. HEAD | | BOLTS, EXTERNAL |
| 44 GASKETS, SHELL | None | TIER RODS |
| 45 CODE REQUIREMENTS | 1962 ASME STAMP Yes | SPEC. Girdler ED-E2 & TEMA "C" (4) |
| 46 WEIGHTS - EACH SHELL | BUNDLE | FULL OF WATER |
| 47 OUTLINE DRWG. NO. | | GASKET DRWG. NOS. |

NOTE: INDICATE AFTER EACH PART WHETHER STRESS RELIEVED (S.R.) AND WHETHER RADIOGRAPHER (X.R.)

REMARKS: (1) High rate of flow is intentional; not req'd for duty. (2) Impact test req'd per code. (3) Inner pipe welded into outer pipe both ends of "U".

(4) Navy shockproof equip. spec. MIL-S-901B (NAVY) dated 4/9/54 applies.

GIRDLER CORPORATION
P. O. BOX 174
LOUISVILLE 1, KENTUCKY

Supplier.....
Shop Location.....
Date..... Ref.....

RECIPROCATING PUMP SPECIFICATION SHEET No. 5414-P-1

1 Girdler's Customer U. S. Navy Girdler Job No. 131-5414
2 Address..... Customer's Ref. No. NOBS 86743
3 Plant Location..... Engr. MWO Check Date 10/1/62
4 Name of Pump Methanol & Condensate Feed (Process) Rev.....
5 Item No. P-1A & P-1B (Duplex) Rev.....
6 No. Req'd 2 Power Steam Proportioning Rev.....

OPERATING CONDITIONS

7 Fluid Pumped (A) Methanol; (B) Condensate Design Discharge Pressure 450 psig.
8 Suction Temp. (A) 30-85; (B) 100 - 200 °F Design Suction Pressure (A) 0-320; (B) 0-350 psig.
9 Gravity @ 60°F (A) 0.795; (B) 1 Design Differential Pressure (3)..... psi.
10 Viscosity (1)..... Cp. @ Suction Temp. NPSH, Design (A) 16; (B) 6 ft.
11 Vapor Pressure (2)..... psia @ Suction Temp. NPSH, Required..... ft.
12 Steam..... psig % Saturated Capacity @ Pumping Temp., Normal..... gpm
13 Current Char. 220/110 Volts 3 Phase 60 Cycle Capacity @ Pumping Temp., Design..... gpm
P-1A; 1.21 gpm
P-1B 1.07 gpm

SPECIFICATIONS

14 Mfr. Size & Model.....
15 Cylinder Design Pressure..... psi Brake Hp, Normal Design.....
16 Steam End D.P. psi T.P. psi Steam Rate #/hr. Normal Des.....
17 Suct. Flange - Steam Liq. Thd. Motor Recommended Hp..... RPM
18 Disch. Flange - Steam Liq. Thd. Drivers to be furnished by Pump mfr.....
19 Piston Speed..... ft/min rpm Drivers to be mounted by " ".....
20 P.M. Main Shaft Gear Shaft Type drive variable speed Guard.....
21 Gear Ratio Type cplg. Falk or eq. Guard yes
22 Suction Valve Size No. Stuffing box.....
23 Area, sq. in. Vel. ft/min. Lantern gland.....
24 Disch. Valve Size No. Lubricator.....
25 Area, sq. in. Vel. ft/min. Relief valve.....
26 Efficiency, Volumetric % Mech. % Capacity adjustment Yes (4)

ADDITIONAL FLUID INFORMATION

27 Abrasive Solids.....
28 Lubricating Properties.....
29 Special Corrosive Properties (pH) =.....

MATERIALS - LIQUID END Mfr. std. for service.

30 Cylinder..... Valves.....
31 Liner..... Valve Seats.....
32 Piston..... Valve Springs.....
33 Piston Rod..... Valve Bolts.....
34 Piston Packing.....
35 Piston Packing Gland.....
36 Base Plate.....

GENERAL INFORMATION

37 Net Wt. Pump & Base..... Cooling Water..... GPM @.....
38 Net Wt. Pump Only..... Motor..... Inspection.....
39 Dimension Print No..... Tests: Hydra..... psig; Other.....
40 Additional Specifications..... Motor Enclosure Cl. 1, Gp. D

41 Remarks: (1) (A) 0.84 - 0.63 (B) 0.73 - 0.29 (2) (A) 0.52 - 3.04; (B) 1 - 12 (3) (A) 130-450;
42 (B) 100 - 450 (4) Variable speed drive must lend itself to automatic control by Purchaser; also
43 manual stroke adjustment while pumping is req'd on both heads. Combination of these controls
44 must allow turndown on P-1A to 0.06 gpm and P-1B to 0.05 gpm.

GIRDLER CORPORATION
P. O. BOX 174
LOUISVILLE 1, KENTUCKY

Supplier _____
Shop Location _____
Date _____ Ref. _____

RECIPROCATING PUMP SPECIFICATION SHEET No. 5414-P-2

1 Girdler's Customer U. S. Navy Girdler Job No. 131-5414
2 Address _____ Customer's Ref. No. NOBS 86743
3 Plant Location _____ Engr. MWO Check Date 10/1/62
4 Name of Pump Methanol and Condensate Fuel Rev. _____
5 Item No. P-2A & P-2B (Duplex) Rev. _____
6 No. Req'd 2 Power Steam Proportioning _____ Rev. _____

OPERATING CONDITIONS

7 Fluid Pumped (A) Methanol; (B) Condensate Design Discharge Pressure 450 psig.
8 Suction Temp. (A) 30 - 85; (B) 100 - 200 °F Design Suction Pressure (A) 0-320; (B) 0-350 psig.
9 Gravity @ 60°F (A) 0.795; (B) 1 Design Differential Pressure (3) psi
10 Viscosity (1) Cp. @ Suction Temp. NPSH, Design (A) 16; (B) 6 ft.
11 Vapor Pressure (2) psia @ Suction Temp. NPSH, Required _____ ft.
12 Steam _____ psig _____ % Saturated Capacity @ Pumping Temp., Normal _____ gpm
13 Current Char. 220/440 Volts 3 Phase 60 Cycle Capacity @ Pumping Temp., Design _____ gpm
P-2A; 0.24 gpm
P-2B; 0.48 gpm

SPECIFICATIONS

14 Mfr. Size & Model _____
15 Cylinder Design Pressure _____ psi Brake Hp Normal _____ Design _____
16 Steam End D.P. _____ psi T.P. _____ psi Steam Rate #/hr. Normal _____ Des. _____
17 Suct. Flange - Steam _____ Liq. _____ Thd. _____ Motor Recommended _____ Hp _____ RPM
18 Disch. Flange - Steam _____ Liq. _____ Thd. _____ Driver to be furnished by _____ Pump mfr. _____
19 Rotation Speed _____ ft/min _____ rpm Drivers to be mounted by " " _____
20 R.P.M. Main Shaft _____ Gear Shaft _____ Type drive variable speed Guard _____
21 Gear Ratio _____ Type cplg. Falk or eq. Guard Yes
22 Suction Valve Size _____ No. _____ Stuffing box _____
23 Area, sq. in. _____ Vel. ft/min. _____ Lantern gland _____
24 Disch. Valve Size _____ No. _____ Lubricator _____
25 Area, sq. in. _____ Vel. ft/min. _____ Relief valve _____
26 Efficiency Volumetric _____ % Mech. _____ % Capacity adjustment Yes (4)

ADDITIONAL FLUID INFORMATION

27 Abrasive Solids _____
28 Lubricating Properties _____
29 Special Corrosive Properties (pH = _____)

MATERIALS - LIQUID END Mfr. std. for service

30 Cylinder _____ Valves _____
31 Liner _____ Valve Seats _____
32 Piston _____ Valve Springs _____
33 Piston Rod _____ Valve Bolts _____
34 Piston Packing _____
35 Piston Packing Gland _____
36 Base Plate _____

GENERAL INFORMATION

37 Net Wt., Pump & Base _____ Cooling Water _____ GPM @ _____
38 Net Wt., Pump Only _____ Motor _____ Inspection _____
39 Dimension to interface _____ Tests: Hydra _____ psig; Other _____
40 Additional Specifications _____ Motor Enclosure Cl. I, Gp. D
41 Remarks (1) (A) 0.841 - 0.634; (B) 0.73 - 0.29 (3) (A) 130-450; (B) 100-450
42 (2) (A) 0.52 - 3.04; (B) 1-12
43 (4) Variable speed drive must lend itself to automatic control by Purchaser; also manual stroke adjustment while pumping is req'd on both heads. Combination of these controls must allow turndown on P-2A to 0.01 gpm and P-2B to 0.02 gpm.

MECHCOR CORPORATION
P. O. BOX 174
LOUISVILLE 1, KENTUCKY

Supplier
Shop Location _____
Date _____ Ref. _____

RECIPROCATING PUMP SPECIFICATION SHEET No. 5414-P-3

1 Gardner's Customer U. S. Navy Gardner Job No. 131-5414
 2 Address _____ Customer's Ref. No. NOBS 86743
 3 Plant Location _____ Engr. MWO Check Date 10/1/62
 4 Name of Pump Make-Up Condensate Pump Rev. _____
 5 Item No. P-3 Rev. _____
 6 No. Rec'd 1 Power Steam Proportioning Rev. _____

OPERATING CONDITIONS

7 Fluid Pumped Condensate Design Discharge Pressure 350 psig
 8 Suction Temp. 100 °F Design Suction Pressure 0 psig
 9 Gravity @ 60°F 1 Design Differential Pressure 350 psi
 10 Viscosity 0.73 Cp. @ Suction Temp. NPSH, Design 16 ft.
 11 Vapor Pressure 1 psia @ Suction Temp. NPSH, Required _____ ft.
 12 Steam _____ psig _____ % Saturated Capacity @ Pumping Temp., Normal _____ gpm
 13 Current Char. 220/440 Volts 3 Phase 60 Cycle Capacity @ Pumping Temp., Design 0.2 gpm

SPECIFICATIONS

14 Mfr. Size & Model _____
 15 Cylinder Design Pressure _____ psi Brake Hp Normal _____ Design _____
 16 Steam End D.P. _____ psi T.P. _____ psi Steam Rate /hr., Normal _____ Des. _____
 17 Suct. Flange - Steam _____ Liq. _____ Motor Recommended _____ Hp _____ RPM
 18 Disch. Flange - Steam _____ Liq. _____ Driver to be furnished by Pump mfr.
 19 Piston Speed _____ ft/min _____ rpm Drivers to be mounted by " " _____
 20 RPM, Main Shaft _____ Gear Shaft _____ Type drive variable speed Guard _____
 21 Gear Ratio _____ Type cplg. Falk or eq. Guard yes
 22 Suction Valve Size _____ No. _____ Stuffing box _____
 23 Area, sq. in. _____ Vel. ft/min. _____ Lantern gland _____
 24 Disch. Valve Size _____ No. _____ Lubricator _____
 25 Area, sq. in. _____ Vel. ft/min. _____ Relief valve _____
 26 Efficiency, Volumetric _____ % Mech. _____ % Capacity adjustment Yes; while pumping (1)

ADDITIONAL FLUID INFORMATION

27 Abrasive Solids _____
 28 Lubricating Properties _____
 29 Special Corrosive Properties {pH} _____

MATERIALS - LIQUID END Mfr. std. for service

30 Cylinder _____ Valves _____
 31 Liner _____ Valve Seats _____
 32 Piston _____ Valve Springs _____
 33 Piston Rod _____ Valve Bolts _____
 34 Piston Packing _____
 35 Piston Packing Gland _____
 36 Base Plate _____

GENERAL INFORMATION

37 Net Wt., Pump & Base _____ Cooling Water _____ GPM @ _____
 38 Net Wt., Pump Only _____ Motor _____ Inspection _____
 39 Dimension Print No. _____ Tests: Hydro _____ psig; Other _____
 40 Additional Specifications _____ Motor Enclosure Cl. I, Gp. D
 41 Remarks: (1) Combination of variable speed and stroke adjustment must allow turndown to
 42 0.01 gpm.
 43 _____
 44 _____
 45 _____

GIRDLER CORPORATION
P. O. BOX 174
LOUISVILLE 1, KENTUCKY

Supplier.....
Shop Location.....
Date..... Ref.

RECIPROCATING PUMP SPECIFICATION SHEET No. 5414-P-4

1 Girdler's Customer U. S. Navy Girdler Job No. 131-5414
2 Address..... Customer's Ref. No. NOBS 85743
3 Plant Location..... Engr. MWO Check Date: 9/28/62
4 Name of Pump Liquid Oxygen Pump Rev.....
5 Item No. P-4 Rev.....
6 No. Rec'd 1 Power Steam Proportioning Rev.....

OPERATING CONDITIONS

7 Fluid Pumped Liquid O₂ Design Discharge Pressure 450 psia
8 Suction Temp. -297 °F Design Suction Pressure 0 psia
9 Gravity @ 60°F Gas Design Differential Pressure 450 psia
10 Viscosity..... Cp. @ Suction Temp. NPSH, Design As req'd ft.
11 Vapor Pressure 14.7 psia @ Suction Temp. NPSH, Required..... ft.
12 Steam psig % Saturated Capacity @ Pumping Temp., Normal..... gpm
13 Current Char. Volts Phase Cycle Capacity @ Pumping Temp., Design 0.5 gpm

SPECIFICATIONS

14 Mfr. Size & Model.....
15 Cylinder Design Pressure..... psi Brake H_y Normal..... Design.....
16 Steam End D. P. psi T. P. psi Steam Rate //hr. Normal..... Des.....
17 Suct. Flange - Steam..... Liq..... Motor Recommended..... Hp..... RPM
18 Disch. Flange - Steam..... Liq..... Driver to be furnished by Pump mfr.
19 Piston Speed..... ft/min..... Drivers to be mounted by " " "
20 RPM, Main Shaft..... Gear Shaft..... Type drive..... Gear..... Guard.....
21 Gear Ratio..... Type cplg. Falk or eq. Guard Yes.....
22 Suction Valve Size..... No. Stuffing box.....
23 Area, sq. in. Vel. ft/min. Lantern gland.....
24 Disch Valve Size..... No. Lubricator.....
25 Area, sq. in. Vel. ft/min. Relief valve.....
26 Efficiency, Volumetric..... % Mech. % Capacity adjustment Yes; while pumping (1)

ADDITIONAL FLUID INFORMATION

27 Abrasive Solids.....
28 Lubricating Properties.....
29 Special Corrosive Properties (pH).....

Mfr. Recommend MATERIALS - LIQUID END

30 Cylinder..... Valves.....
31 Liner..... Valve Seats.....
32 Piston..... Valve Springs.....
33 Piston Rod..... Valve Bolts.....
34 Piston Packing.....
35 Piston Packing Gland.....
36 Base Plate.....

GENERAL INFORMATION

37 Net Wt., Pump & Base..... Cooling Water..... GPM @.....
38 Net Wt., Pump Only..... Motor..... Inspection.....
39 Dimensional Draw. Ltr..... Tests: Hydro..... psig; Other.....
40 Additional Specifications..... Motor Enclosure..... Cl. 1, Gp. D.....
41 Remarks: (1) Must be able to turn down to 0.02 gpm, either by stroke, adjustment, or by variable drive or both. Variable drive may be either a direct current device or a magnetic clutch arrangement.

UNCLASSIFIED

UNCLASSIFIED