

UNCLASSIFIED

---

---

AD 294 360

*Reproduced  
by the*

ARMED SERVICES TECHNICAL INFORMATION AGENCY  
ARLINGTON HALL STATION  
ARLINGTON 12, VIRGINIA



---

---

UNCLASSIFIED

NOTICE: When government or other drawings, specifications or other data are used for any purpose other than in connection with a definitely related government procurement operation, the U. S. Government thereby incurs no responsibility, nor any obligation whatsoever; and the fact that the Government may have formulated, furnished, or in any way supplied the said drawings, specifications, or other data is not to be regarded by implication or otherwise as in any manner licensing the holder or any other person or corporation, or conveying any rights or permission to manufacture, use or sell any patented invention that may in any way be related thereto.

CATALOGED BY ASTIA  
AS AD NO. \_\_\_\_\_

294360

294 360

# FINAL REPORT

Contract No. ARDS-494

Preliminary Investigation for  
Wireless Control System for Airport Lighting

Report Date July 12, 1962

ASTIA  
JAN 21 1963  
RECEIVED

Prepared for  
FEDERAL AVIATION AGENCY  
SYSTEMS RESEARCH AND DEVELOPMENT SERVICE

BY

# ENGELHARD

I N D U S T R I E S , I N C .

INDUSTRIAL EQUIPMENT DIVISION  
INSTRUMENTS AND SYSTEMS SECTION  
850 PASSAIC AVENUE  
EAST NEWARK, NEW JERSEY

FINAL REPORT

Contract No. ARDS-494

Preliminary Investigation for  
Wireless Control System for Airport Lighting

Report Date July 12, 1962

Prepared for  
FEDERAL AVIATION AGENCY  
SYSTEMS RESEARCH AND DEVELOPMENT SERVICE

BY

ENGELHARD INDUSTRIES, INC.  
Industrial Equipment Division  
Instruments and Systems Section  
850 Passaic Avenue  
East Newark, New Jersey

"This report has been prepared by Engelhard Industries, Inc., for the Systems Research and Development Service (formerly Bureau of Research and Development), Federal Aviation Agency, under Contract No. ARDS-494. The contents of this report reflect the views of the contractor, who is responsible for the facts and the accuracy of the data presented herein, and do not necessarily reflect the official views or policy of the FAA."

ABSTRACT

Engelhard Industries, Inc., East Newark, N. J.  
PRELIMINARY INVESTIGATION FOR WIRELESS CONTROL SYSTEM FOR  
AIRPORT LIGHTING, July 12, 1962, 42 pp, includ. 32 illus.  
(Contract No. ARDS-494)

Investigations were conducted within the scope of the contract in order to determine the parameters affecting the transmission of underground signals for the purpose of wireless communication. The results of these tests are summarized by the following equation:

$$E = 32.5 \frac{\rho}{R^3} \sqrt{\frac{PL}{f}}$$

It has been determined that with low power, low frequency transmission over a short antenna, as defined in the contract, a practical transmission distance is one mile. With moderate increases in the power and antenna length, transmission up to 3 miles is practical.

## SUMMARY

The investigations performed by Engelhard Industries, Inc., Instruments and Systems Section for the Federal Aviation Agency, Bureau of Research and Development under contract ARDS-494 were conducted in three phases, Initial Evaluation, Equipment Design and Field Test.

In the Initial Evaluation phase transmission, tests were conducted over very short distances in order to determine signal to noise ratio, frequency response, and antenna characteristics. It was found that large 60 cycle signals were induced on the receiving electrodes. In addition, it was determined that the received signal was inversely proportional to the square root of the transmitted frequency for frequencies between 10 and 100 cycles per second.

A special receiver and transmitter were constructed. The receiver had an overall gain at 35 cycles of +110 db and at 60 cycles of less than -10 db for an overall rejection of greater than 120 db. A transmitter was constructed which would deliver a maximum power of 250 watts at voltages between 15 and 400 volts at frequencies between 20 and 100 cycles per second.

Field testing was conducted to determine various factors affecting transmission. The results of these tests are as follows:

- (a) Electrode Configuration -  
Axial alignment of receiving and transmitting electrodes gave better reception in one instance, and no improvement in others.
- (b) Resistivity of transmitting media -  
The received signal increases linearly with higher resistivity. In general, the received noise also increases with resistivity and gives only a small improvement in signal to noise ratio.
- (c) Antenna Length -  
Received signal increases in proportion to the square root of the transmitter or receiver antenna length.
- (d) Power -  
Received signal increases as the square root of the transmitted power.

- (e) Distance -  
Received signal decreases as the reciprocal of the distance cubed.
- (f) Interference with ILS -  
No interference was detected.
- (g) External interference -  
Fluctuations in the receiver noise and lightning produced a transient of approximately 2 1/2 second time constant. This response is inherent to the receiver.
- (h) Signal discrimination -  
The receiver response was down -20 db at less than  $\pm 1$  cps from the center frequency of 35 cps.

Experiment has established the equation:

$$E_{rec} = 32.5 \frac{\rho}{R^3} \sqrt{\frac{PL}{F}}$$

Where

$\rho$  is the soil resistivity in ohm-m  
 R is the distance in m  
 P is the power in watts  
 L is the antenna length in meters  
 f is the frequency in cps  
 Erec is the received voltage on a 1 meter receiving antenna

## TABLE OF CONTENTS

1.	Introduction	
	1.1 Initial Evaluation	1-1
	1.2 Equipment Design	1-2
	1.2 Tests	1-2
2.	Initial Evaluation	
	2.1 Purpose	2-1
	2.2 Preliminary Test Arrangement	2-1
	2.3 Noise Level	2-2
	2.4 Frequency Response	2-4
	2.5 Signal Strength	2-6
	2.6 Results	2-6
3.	Equipment Design	
	3.1 Receiver	3-1
	3.1.1 Twin-Tee	3-1
	3.1.2 Rejection Filter	3-2
	3.1.3 Band Pass Filter	3-2
	3.1.4 Cathode Follower	3-4
	3.1.5 Tuned Amplifier	3-4
	3.1.6 Complete Receiver	3-5
	3.1.7 Alternative Approaches	3-8
	3.2 Transmitter	3-8
	3.2.1 Power Oscillator	3-11
	3.2.2 Cycle System	3-14
	3.2.3 Impedance Matching	3-14
	3.2.4 Complete Transmitter	3-14
	3.3 Electrodes	3-14
4.	Test Procedure and Results	4-1
	4.1 Electrode Configuration	4-1
	4.1.1 Tests in Soil	4-1
	4.1.2 Tests in low Resistivity Soil	4-2
	4.2 Effect of Resistivity	4-6
	4.2.1 Determination of Soil Resistivity	4-6
	4.2.2 Results	4-6
	4.3 Signal vs Antenna Length	4-6

4.4	Signal vs Power	4-10
4.5	Signal Discrimination	4-10
4.6	External Receiver Interference	4-11
4.7	Interference with ILS	4-11
4.8	Signal vs Distance	4-13
4.9	Summary	4-13
5.	Conclusions	5-1
	Appendix	

## LIST OF ILLUSTRATIONS

<u>FIGURE</u>	<u>TITLE</u>	<u>PAGE</u>
2.1	Preliminary Transmitter and Receiver	2-1
2.2	Electrode Configuration	2-2
2.3, A,B	Noise Level Measurements	2-3
2.4	Table of Noise Frequencies	2-3
2.5	Calibration of Receiver	2-4
2.6	Frequency Response	2-5
2.7	Signal vs Short Distance	2-7
3.1	Twin-Tee	3-1
3.2	Rejection Filter	3-2
3.3	Filter Frequency Responses	3-3
3.4	Rejection Filter	3-4
3.5	Cathode Follower	3-4
3.6	Tuned Amplifier	3-5
3.7	Tuned Amplifier Frequency Response	3-6
3.8	Complete Receiver	3-7
3.9	Receiver Frequency Response	3-9
3.10	Receiver Transient Response	3-10
3.11	Power Oscillator	3-12
3.12	Transmitter - Schematic	3-13
3.13	Transmitter	3-14
4.1	Electrode Configuration	4-2
4.2	Signal vs Configuration	4-3
4.3	Map of Park	4-4
4.4	Test Boat	4-5
4.5	Mobile Transmitter	4-5
4.6	Signal vs Configuration	4-7
4.7	Electrode Installation	4-7
4.8	Signal vs Resistivity	4-8
4.9	Signal vs Antenna Length	4-9
4.10	Receiver Response	4-10
4.11	Map of NAFEC	4-11
4.12	Signal vs Distance	4-14
4.13	Consolidated Data	4-17

1. Introduction

The Instruments and Systems Section of Engelhard Industries, Inc., under Contract AFDS-494 with the Federal Aviation Agency, has completed the preliminary investigations for a wireless control system for airport lighting.

The purpose of these investigations, as set forth in the subject contract, is to demonstrate the feasibility of using low frequency, low power electrical energy impressed upon short length antenna buried in the earth for the remote control of airport lighting equipment.

Under this contract, the following design criteria are established:

"Low Frequency" shall be those frequencies between 10 and 100 cycles per second.

"Low Power" shall be any power up to 250 watts.

"Short Length Antenna" shall be consistent with the power limitations, and should vary up to 30 meters (approximately 100 ft.).

The scope of the tests conducted, as summarized from Article 1A of the contract, are:

- (a) Signal (distance) vs. resistance of media.
- (b) Signal (distance) vs. antenna length.
- (c) Signal (distance) vs. power.
- (d) Receiver signal discrimination.
- (e) External interference.
- (f) System interference with ILS installations.

In order to attain an optimum for the various parameters in the system, the following approach was followed:

1.1 Initial Evaluation

Various items of standard laboratory equipment were assembled to form a preliminary transmitter and receiver. The results of this evaluation were used to establish design requirements for this equipment.

1.2 Equipment Design

Materials were purchased to construct and test a receiver and transmitter in accordance with the Initial Evaluation.

1.3 Tests

Transmission tests were conducted in various media over various distances with different antennas at transmitted power up to 250 watts.

## 2. Initial Evaluation

### 2.1 Purpose

In order to determine in a general way what type of equipment would be necessary, preliminary investigations were conducted over very short distances — 100 and 150 feet outside the laboratory. The purpose of these tests was to determine the range of the following variables:

- (a) Received noise.
- (b) Received signal vs. frequency.
- (c) Received signal strength vs. transmitted power.
- (d) Antenna impedance and orientation.

From these tests, specifications could be formed for the selection of the best receiver, transmitter, and electrodes.

### 2.2 Preliminary Test Arrangement

Laboratory equipment was set up as shown in Figure 2.1. The conventional vacuum tube audio amplifier used in this test had a maximum power output of 70 watts over the frequency range of 20 to 20,000 cycles per second. Taps were available to match the transformer to 4, 8, 16, 72 and 143 ohm loads. The H-P audio oscillator driving this amplifier was used to vary the frequency and power output delivered to the sending electrodes.

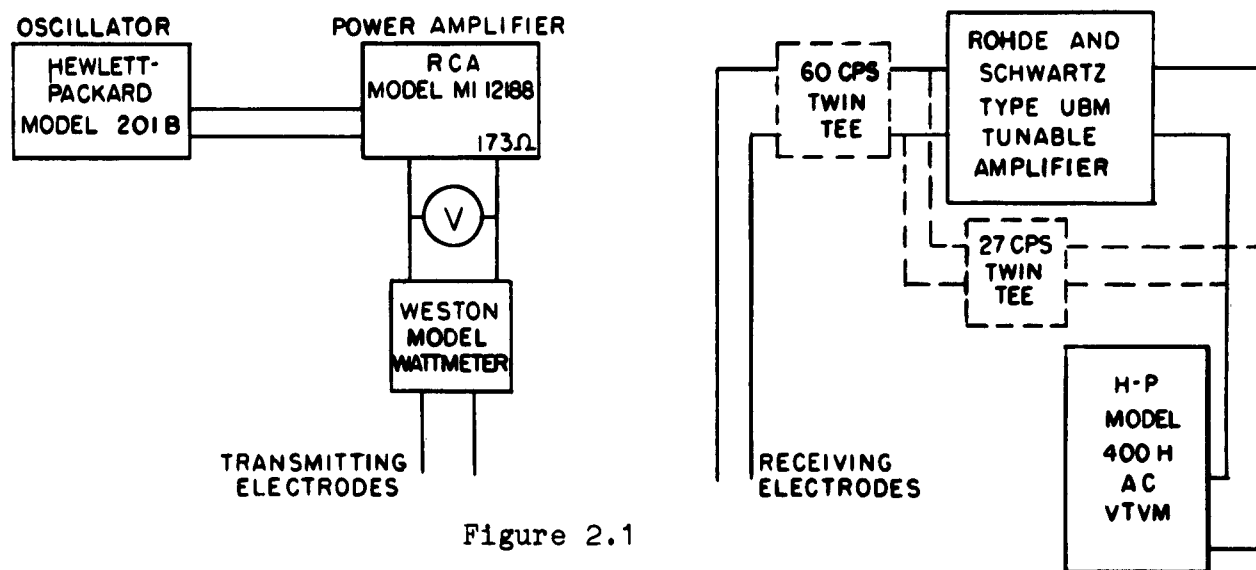

Figure 2.1

### PRELIMINARY TRANSMITTER & RECEIVER

The receiver consists mainly of a Rohde and Schwarz variable frequency tuned amplifier. The tuned frequency can be varied from 45 to 600,000 cycles per second. The maximum gain of the amplifier is 100,000, but is adjustable to lower values. The output of the amplifier is connected to a VTVM and an oscilloscope. In order to extend the range of the tuned amplifier below 45 cycles/second, a fixed frequency twin-tee rejection filter was connected in an external feedback path in order to tune the amplifier for that frequency. A second twin-tee 60 cycle rejection filter was also used at the receiver input.

### 2.3 Noise Level

The first problem encountered in performing these measurements was the large 60 cycle signal induced directly on the receiving electrodes. Electrodes were installed, as shown in Figure 2.2. Various methods of shielding were tried using coaxial and shielded cable grounded at various points. No significant improvement was observed over the use of standard twin conductor neoprene jacketed power cord with twisted leads. The noise level at the receiving electrodes varied between 0.1 and 0.3v RMS (100,000 to 300,000 microvolts).

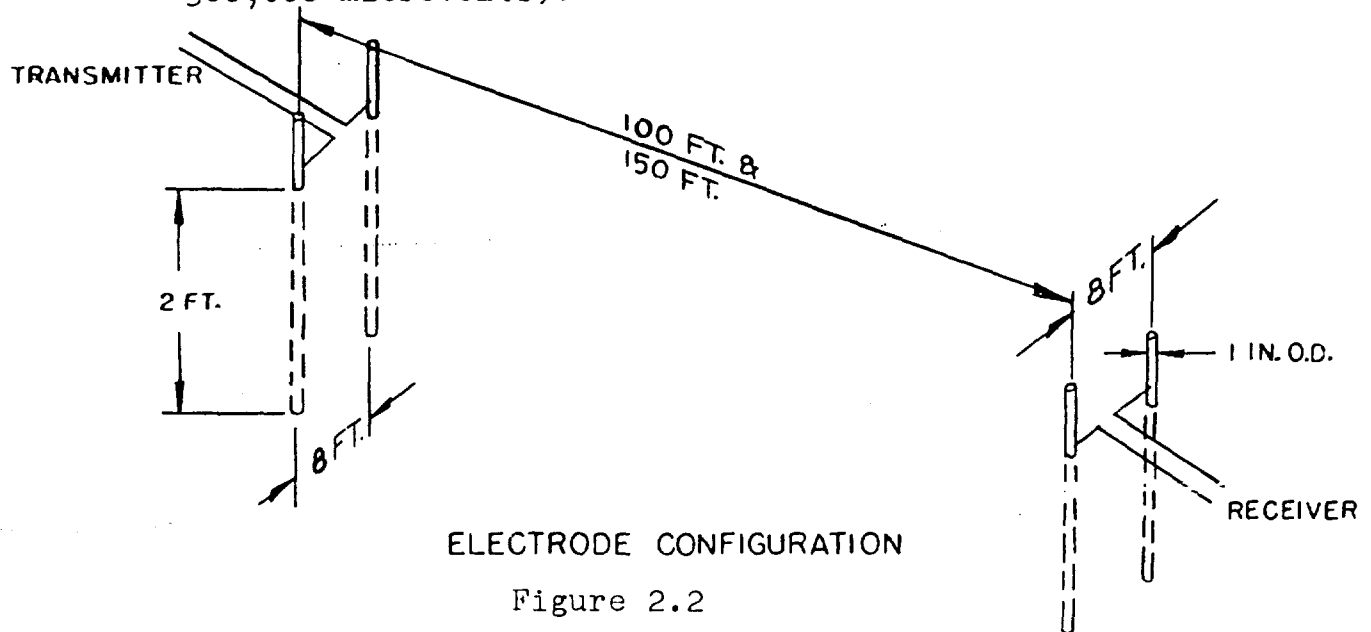

Figure 2.2

The frequency spectrum of the noise present at the receiving electrodes was investigated with the test set up shown in Figure 2.3A and 2.3B. It was soon determined that the noise level at various frequencies changed constantly with no apparent pattern. A short test showed that the load placed upon the various power lines in the vicinity of the plant influenced the harmonic content of the noise.

Table 2.4 lists the frequencies at which the tuned amplifier (Figure 2.3A) indicated a substantial signal was present. No attempt was made to assign absolute values to this noise because of its changing magnitude. The relative indication made in the table would be valid only at one location.

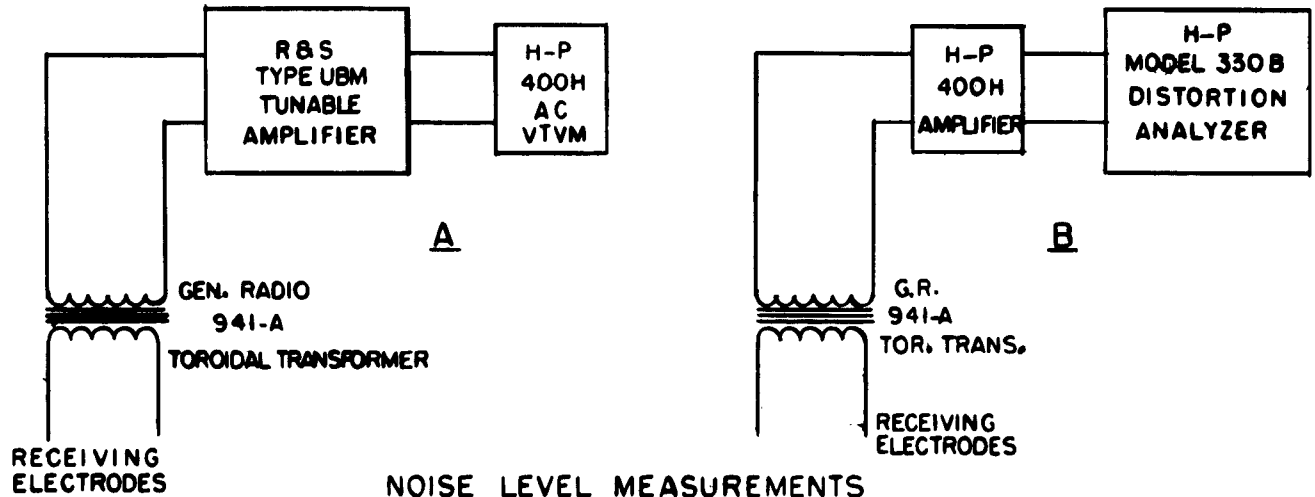

Figure 2.3

The measurement of percent distortion with the distortion analyzer, as shown in Figure 2.3B, indicated a distortion between 5 and 15% at 60 cycles. This means that the 60 cycle comprises between 85 and 95 percent of the total noise signal.

<u>Frequency</u>	<u>Magnitude</u>
60 cycle	Very large
90 cycle	Small
120 cycle	Large
180 cycle	Large
240 cycle	Medium
300 cycle	Small
360 cycle	Medium
390 cycle	Small
400 cycle	Medium
420 cycle	Small
800 cycle	Small
2550 cycle	Medium

Table 2.4

## 2.4 Frequency Response

Single electrodes, as shown in Figure 2.2, were connected to the transmitter and receiver, shown in Figure 2.1. The frequency of the transmitter was adjusted in steps, maintaining a constant output voltage to the transmitting electrodes. The receiver amplifier was tuned for maximum signal at the transmitted frequency. The receiver was left fixed at that frequency setting and the input signal to the receiver was determined by the calibration set up shown in Figure 2.5. The oscillator set at the same frequency as the transmitter and delivering 1.0 volt was connected to a Ratio transformer and the output of the transformer was reduced until the VTVM at the receiver, in Figure 2.1, gave the same indication as when the receiver electrodes were connected. The ratio transformer then indicated exactly the electrode voltage. This arrangement eliminated any variation in gain of the tuned amplifier or input voltage and was particularly valuable when the twin-tee was inserted in the feedback path. A DC measurement was also made by connecting a millivolt potentiometer to the receiving electrodes and impressing various positive and negative DC voltages up to 100v DC on the transmitting electrode pair. The results of the frequency response test are shown graphically in Figure 2.6. Two separate tests were conducted, one during a warm period, and the second when the surface of the ground was frozen.

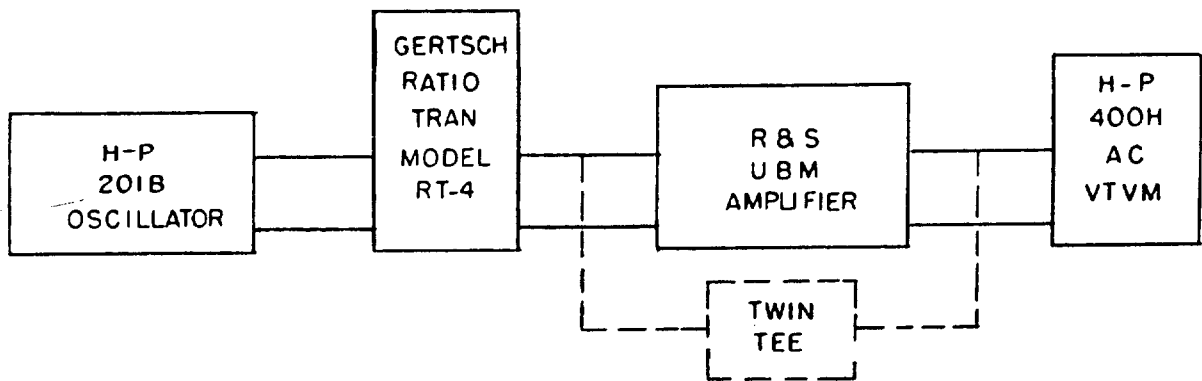

CALIBRATION OF RECEIVER

Figure 2.5

The dashed line on the graph shows a normalized characteristic inversely proportional to the square root of the frequency —

$$E_r = \frac{C}{\sqrt{f}}$$

1

FREQUENCY RESPONSE

100 FT. DISTANCE  
30 WATT POWER  
ELECTRODES FIG. 2.2  
EQUIPMENT FIG. 2.1

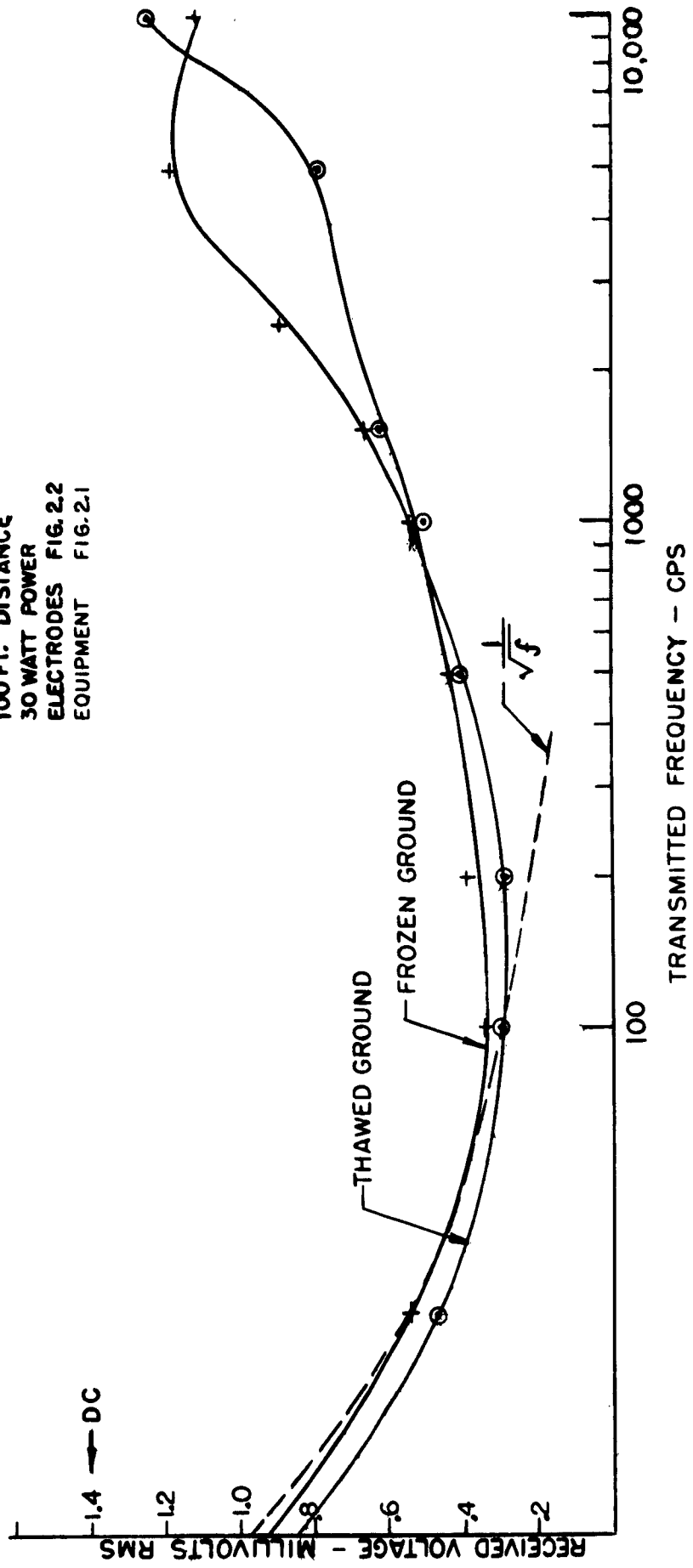

FIG. 2.6

Where the transmitted power and voltage, and electrode separation and length are constant.

It appears that the signal response in the frequencies between 10 and 100 cycles closely follows this relationship (eq. 1). At higher frequencies an increasing received signal is obtained. It is interesting to note that the signal received at 27 cycles is approximately the same as that received at 1000 cycles.

## 2.5 Signal Strength

Preliminary tests were conducted at distances of 100 and 150 ft. separation between transmitting and receiving electrodes, and with an 8 ft. distance between the electrode pairs, as shown in Figure 2.2.

Tests were performed at 27 cps and 1060 cps in order to determine the relationship between input power and received voltage. It was found that at both frequencies, the received voltage bore a linear relation to the transmitted voltage and was a function of the square root of the transmitted power.

The reduction in signal strength between the 100 and 150 ft. separation was approximately proportional to the reciprocal of the distance squared. In Figure 2.7 the data taken in these four tests are plotted.

## 2.6 Results

At the conclusion of these tests, the following results were obtained:

- (a) The received signal would probably be in the region of 1 microvolt.
- (b) The 60 cycle signal present at the receiving electrodes could be as much as 300,000 microvolts. This would require a rejection of 300,000 to 1 between the received signal frequency and 60 cycles.
- (c) Increased signals would be obtained at the lower frequencies (10 to 40 cycles).
- (d) The transmitter must be very flexible. In the scope of the tests to be performed, power of up to 250 watts at voltages from 20 to 400 volts and frequencies from 10 to 100 cycles would be required. Conventional vacuum tube amplifiers would not be satis-

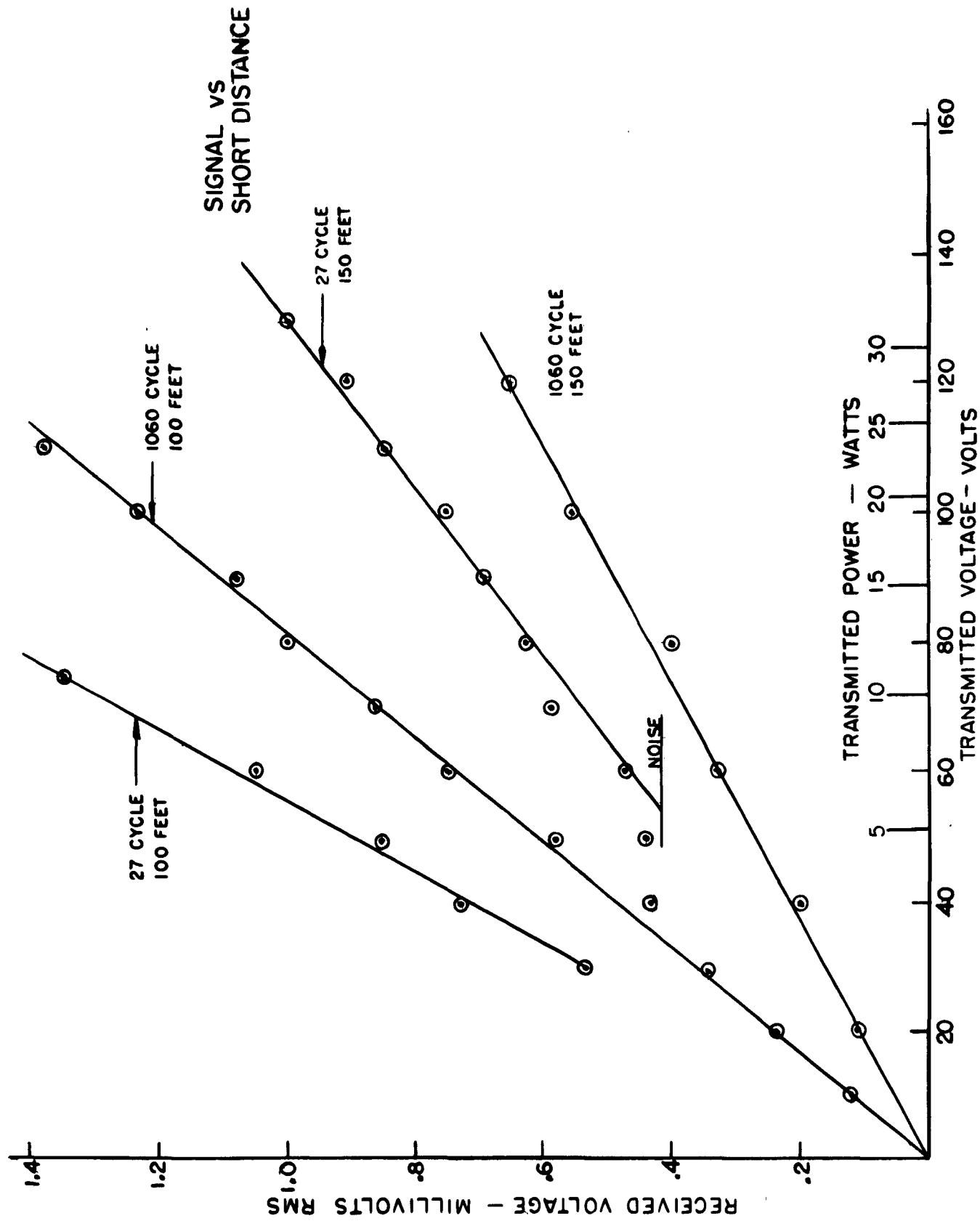

FIG. 2.7

factory since only a limited number of impedances could be matched efficiently.

- (e) It appeared at this time that the voltage appearing at the receiver would follow an equation such as —

$$E_{rec} = \frac{C' \sqrt{P/f}}{r^2}$$

2

where C' was a constant involving the design of the electrodes, their spacing and the soil resistivity, P is the transmitted power, f is frequency, and r is the separation between the transmitter and receiver, Subsequent tests, described in Section 4, proved this equation to be only partially correct.

### 3. Equipment Design

The fundamental electrical requirements for the transmitter and receiver had been set forth in the Engelhard Industries proposal (See Appendix, Ref. 1) and in Section 2.6. Because of the time limitations of the contract, it was found that it would be impossible to obtain the necessary frequency sensitive filters and relays in the frequency range of 10 to 100 cycles, except at 60 cycles. These components are manufactured commercially only to order. It was therefore necessary to construct the required filters and amplifiers from standard components.

#### 3.1 Receiver

In order to avoid the time consuming process of building a complete receiver and then troubleshooting and modifying the complete unit, a number of plug-in assemblies with different functions was constructed. These plug-ins could then be adjusted individually by different personnel and assembled in order on one chassis. The sequence of the plug-in assemblies could be changed to produce a receiver with the optimum characteristics.

##### 3.1.1 Twin-Tee

As described in Section 2.2, a 60 cycle twin-tee filter was constructed and assembled into a plug-in. The schematic of this filter is shown in Figure 3.1, and the frequency response in Figure 3.3. This type of filter is fully described in various literature (Appendix, Ref. 2), and is of standard design. Careful component selection is required for optimum results, however, and the twin-tee used in these tests had a rejection of 36db.

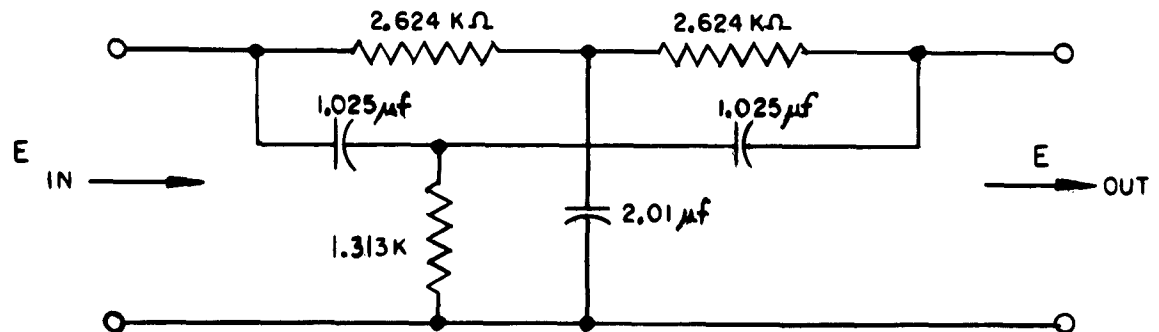

TWIN-TEE 60 CYCLE REJECTION FILTER

Figure 3.1

### 3.1.2 Rejection Filter

A rejection filter for 60 and 120 cycles was constructed and tested, as shown in the schematic diagram, Figure 3.2. A parallel LC element tuned for 60 cycles is shunted by a series LC arm tuned for 120 cycles. The response of this filter is shown in Figure 3.3.

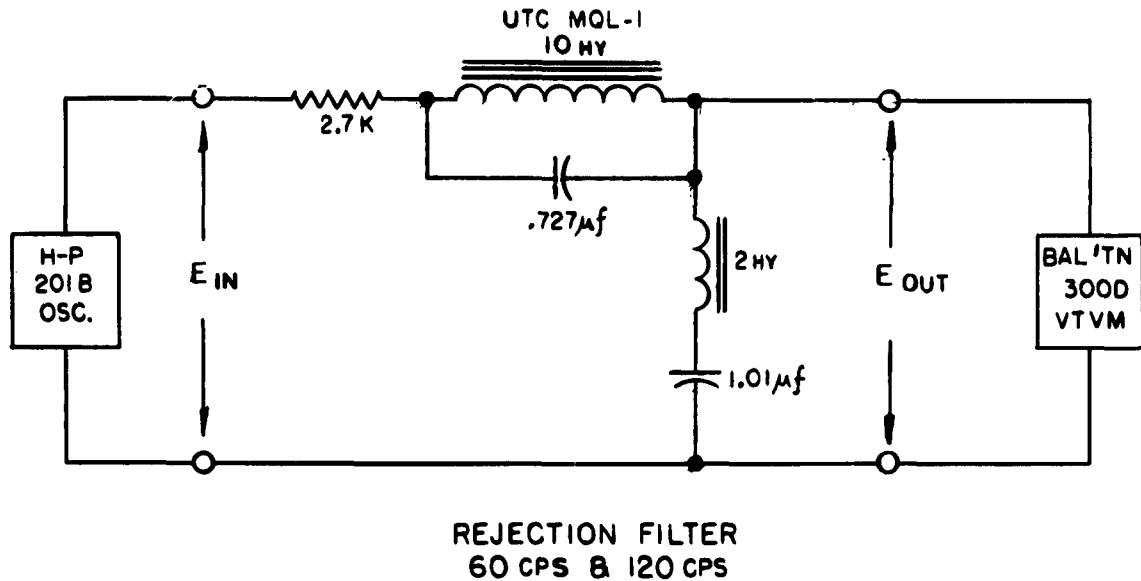

Figure 3.2

### 3.1.3 Band Pass Filter

A standard 100 cycle band pass filter manufactured by UTC as their LMI-100 has the characteristics, shown in Figure 3.3, and was connected directly to the 60/120 cycle rejection filter described in Paragraph 3.1.2. The response of this composite filter (Figure 3.4) is shown in Figure 3.3.

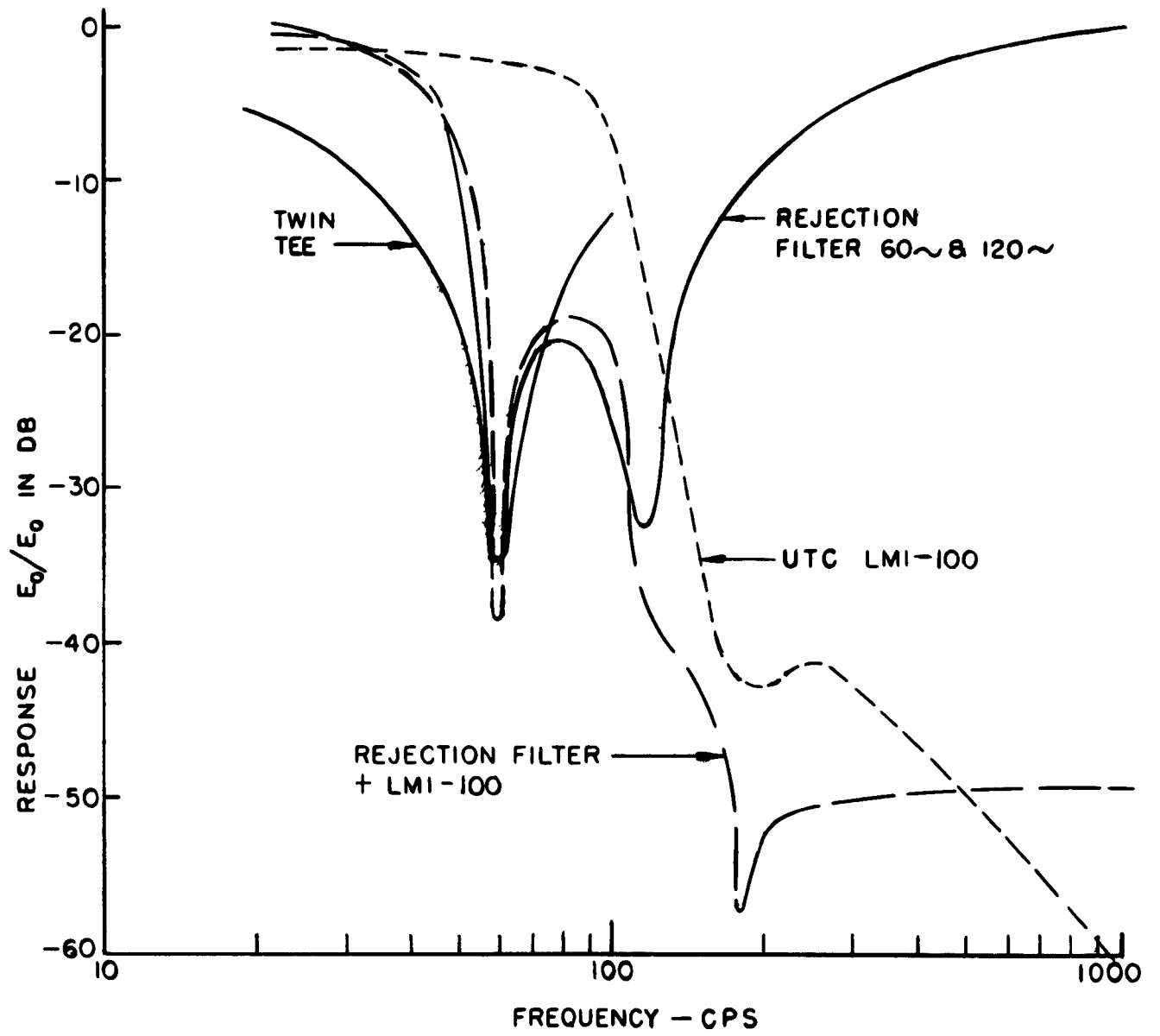
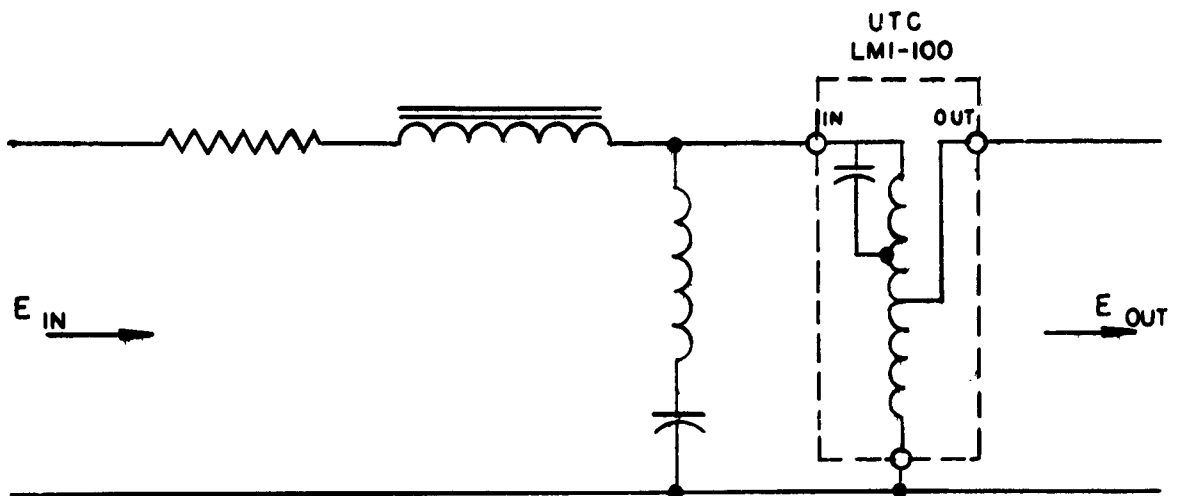

FIG. 3.3



60 & 120 CPS REJECTION FILTER + LMI-100

Figure 3.4

3.1.4 Cathode Follower

Several cathode followers were constructed to serve as isolation devices between filters and amplifiers. High frequency RC filtering was incorporated to eliminate any radio interference. The schematic of the cathode follower is shown in Figure 3.5.

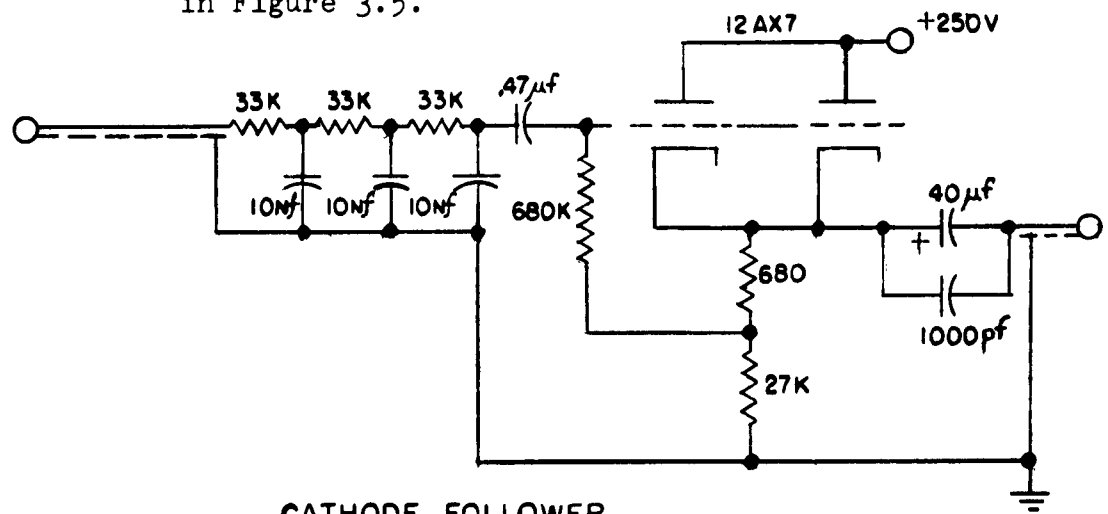

CATHODE FOLLOWER

Figure 3.5

3.1.5 Tuned Amplifier

Several identical frequency selective amplifiers were constructed, as shown in Figure 3.6. These amplifiers incorporate a single pentode stage



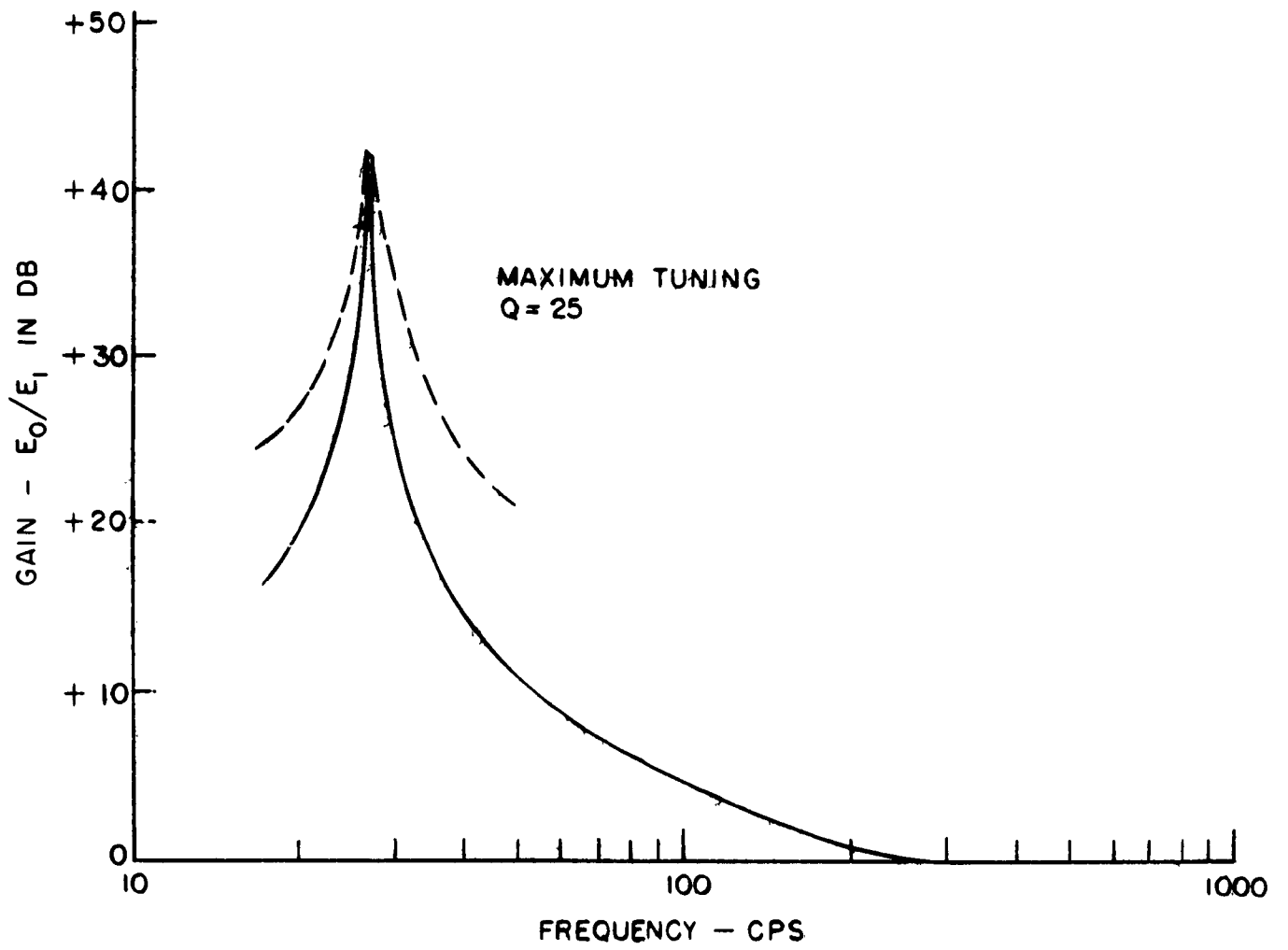
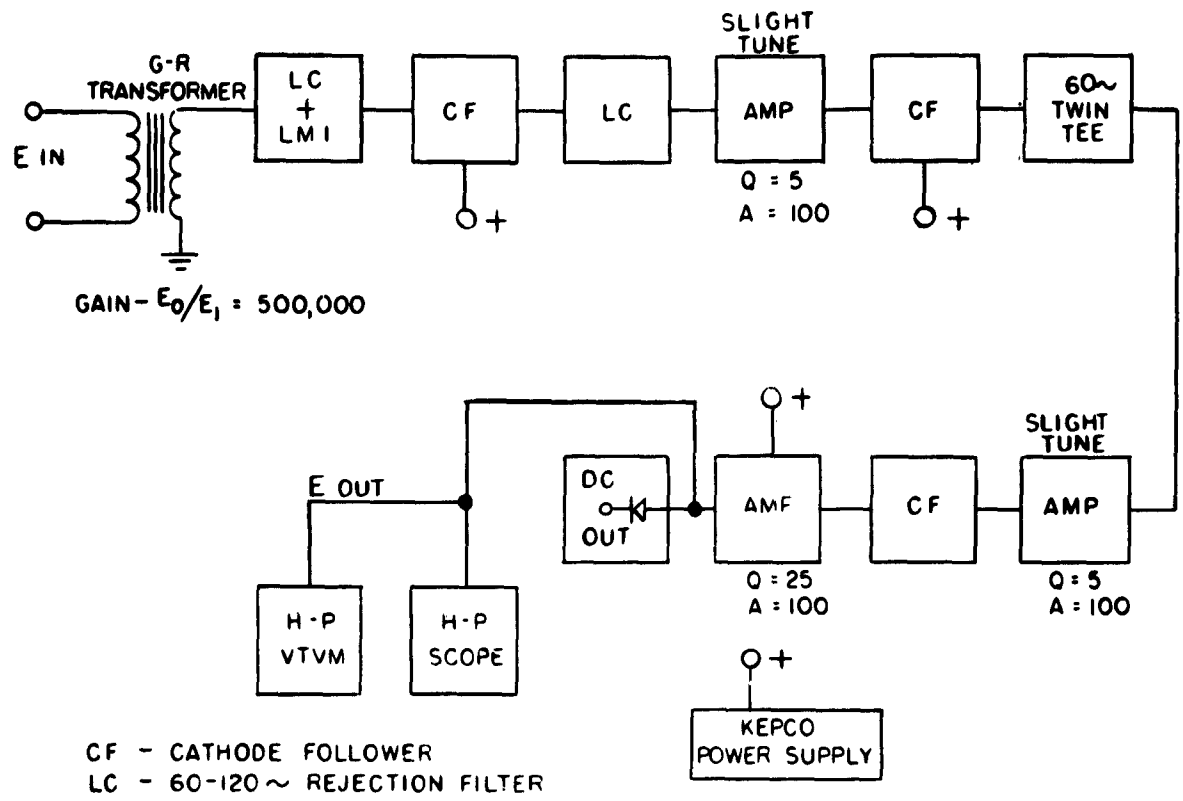

FIG. 3.7



COMPLETE RECEIVER

FIG. 3.8

After numerous trials, the particular sequence of components and amplifier adjustment was found to be the optimum arrangement for the circuitry and packaging used. The overall response of the receiver is shown in Figure 3.9. The bandwidth is only  $\pm 1$  cps, and at frequencies of  $\pm 2$  cps, the response is down over 20db. The final receiver was tested, and it was impossible to detect any 60 cycle output even with 10 volts (10 million microvolts) applied to the input.

The receiver has an overall gain of 500,000 and a noise level referred to the input of less than 1 microvolt.

With 5 microvolt of 35 cycle applied, there was no change in the output when 300,000 microvolt of 60 cycle or higher frequencies were added to the signal.

The receiver does exhibit a transient response to a rapidly changing amplitude of 60 cycle. With no 35 cycle applied to the input, a sudden change of 60 cycle from 50,000 to 60,000 microvolts will produce a 35 cycle transient in the output, as shown in Figure 3.10. The cause of this transient is due to the particular tuned amplifiers employed and could be reduced with other circuitry. The net effect of this long time transient behavior was to limit the separation of the receiving electrodes. This fact is discussed further in Section 4.

#### 3.1.7 Alternative Approaches

Several other circuits were built and tested for use in the receiver, but were discarded because the components described previously performed better.

These circuits involved special unity gain cathode followers, Wien bridge rejection amplifiers, and numerous filter configurations similar to the one shown in Figure 3.2.

### 3.2 Transmitter

As originally conceived, the transmitter would consist of an AC generator driven at a variable speed by a motor and variable speed reducer or by a variable speed motor. Low

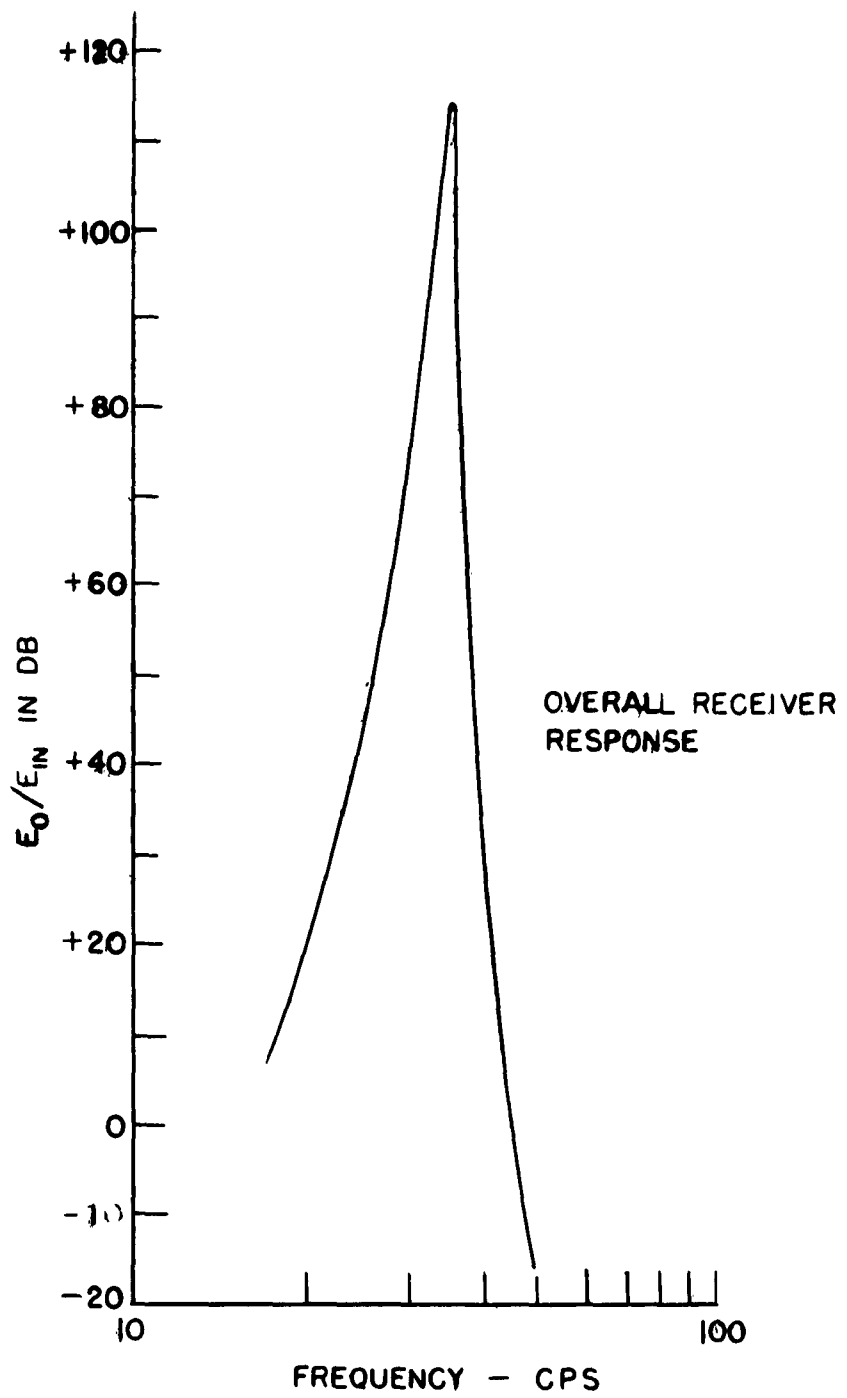

FIG. 3.9

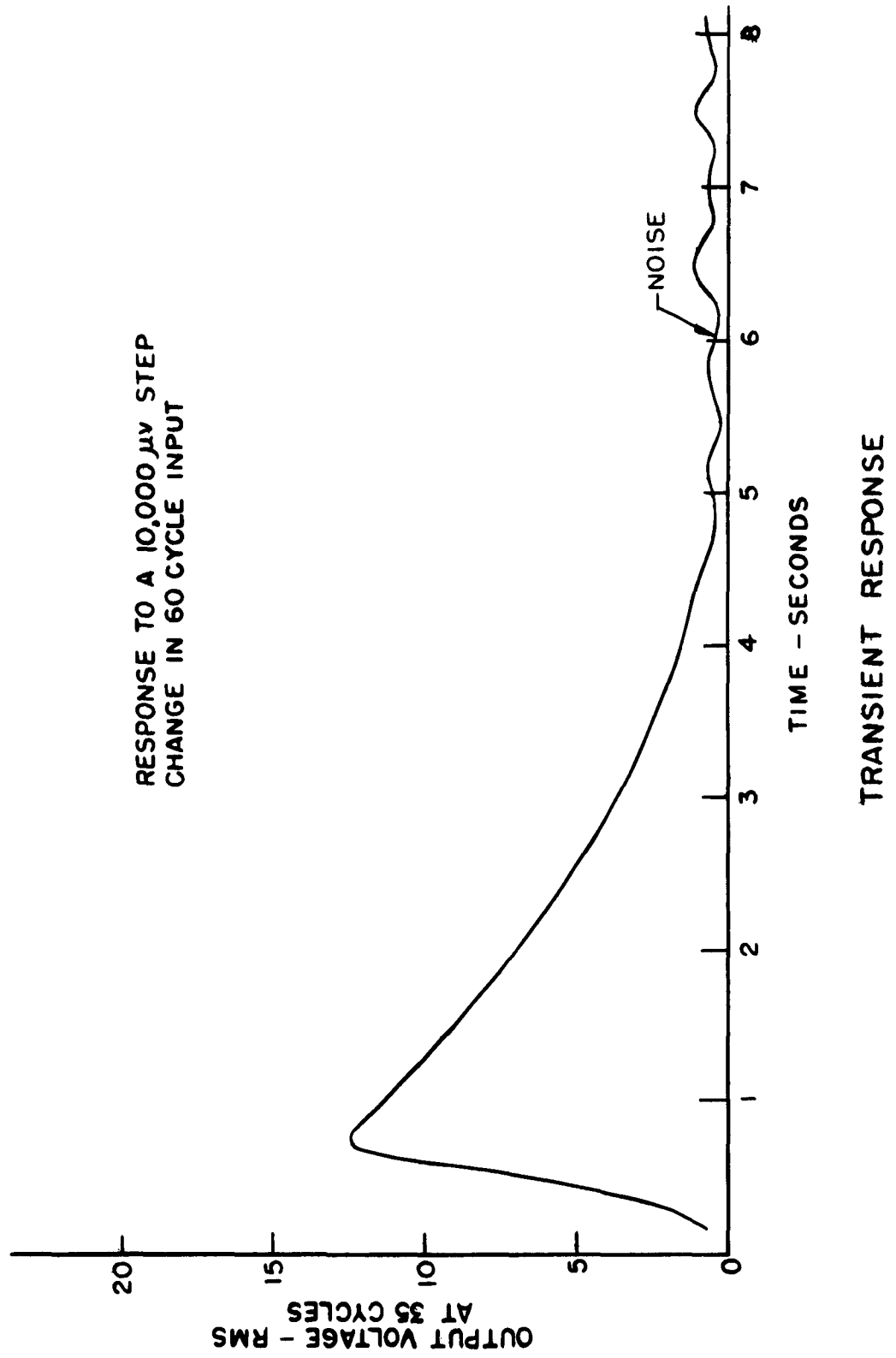

FIG. 3.10

frequency AC generators were found to be quite heavy, and no variable speed drives with a 10 to 1 ratio and low power output could be located. A 1000 watt motor generator set which was suitable weighed over 800 pounds. This large weight would make the tests particularly cumbersome. A variable frequency parallel inverter using silicon controlled rectifiers was constructed. The basic operation of the inverter is as follows:

- (a) The available AC power is transformed to an adjustable DC voltage by using an adjustable autotransformer (variac) and rectifier bridge. This adjustable DC is used to change the power level of the output.
- (b) The inverter converts the DC to an adjustable frequency AC voltage which may be transformed to any voltage or current necessary.
- (c) An oscillator drives the gates of the silicon controlled rectifiers to produce the variable frequency.

The complete inverter capable of delivering up to 300 watts weighs less than 50 pounds. The circuitry is as follows:

#### 3.2.1 Power Oscillator

The power oscillator consists of the three sections described previously, namely power supply, inverter, and driver. These components are shown in Figure 3.11. The complete circuit description is covered in Ref. 3 of the Appendix.

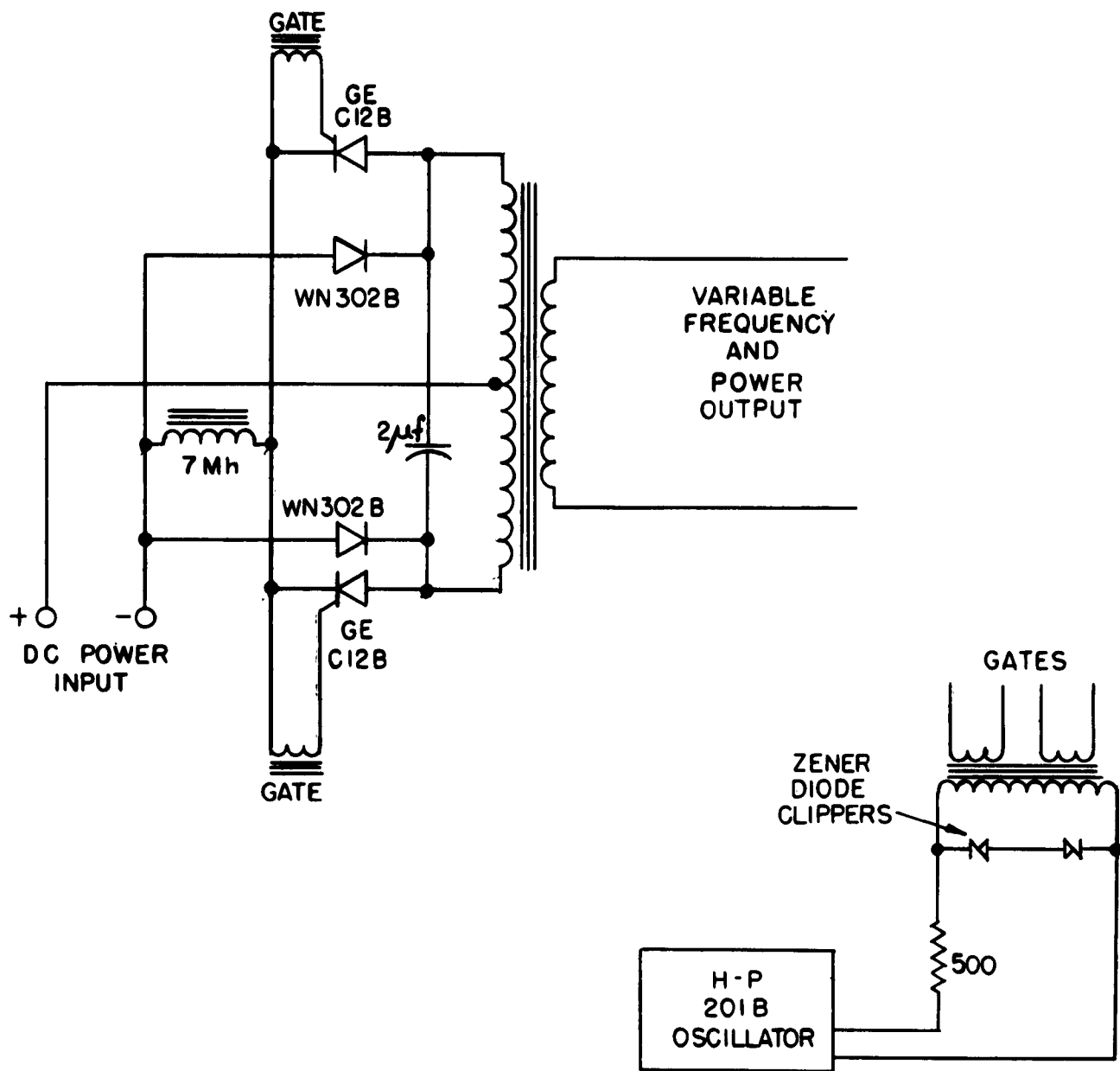

POWER OSCILLATOR

FIG. 3.11

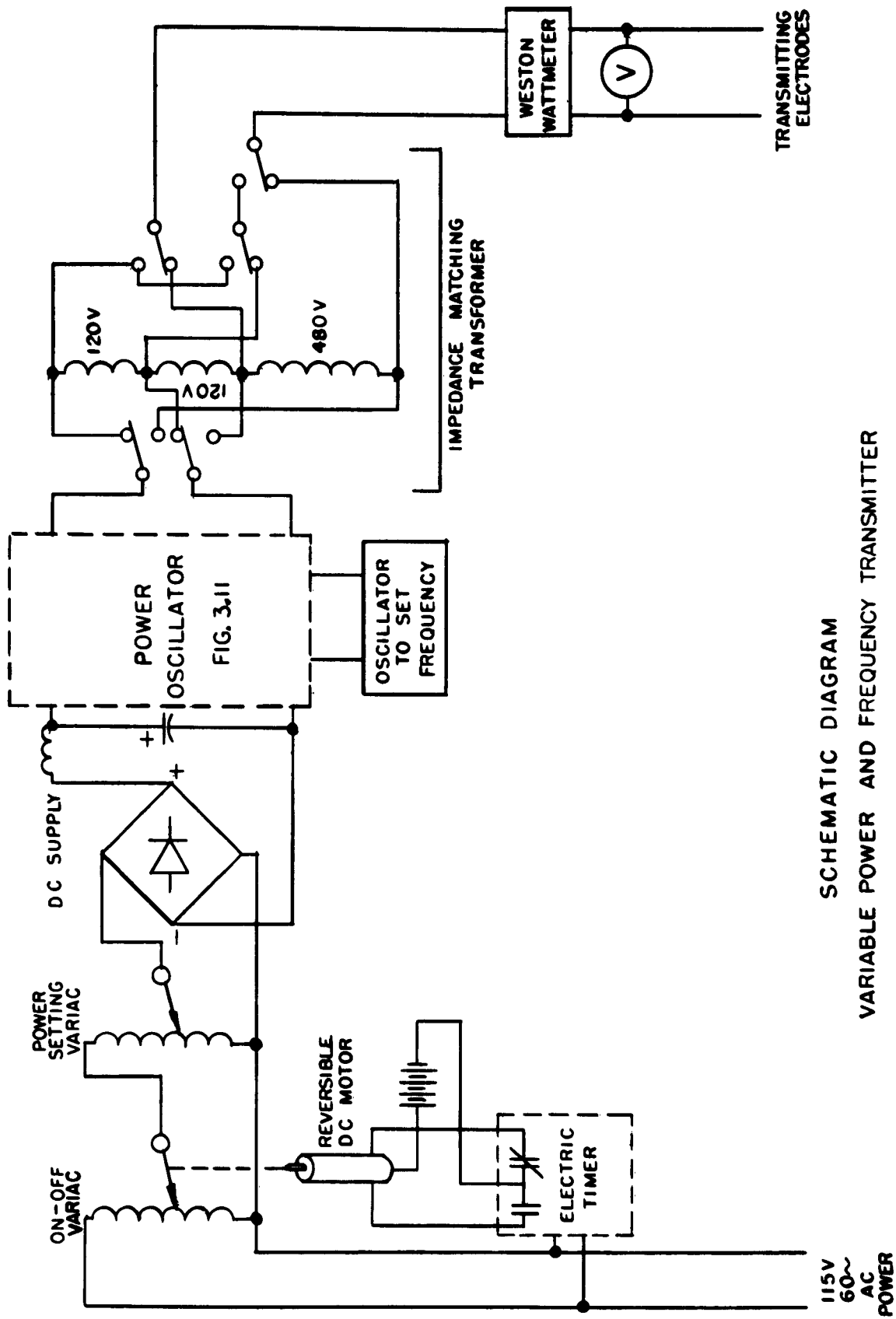

SCHMATIC DIAGRAM  
VARIABLE POWER AND FREQUENCY TRANSMITTER

FIG. 3.12

### 3.2.2 Cycle System

A variable time on and off system was connected to the input of the power oscillator. This permitted automatic cycling of the transmitter between some preset maximum power set by the variac in the power oscillator and zero power output.

### 3.2.3 Impedance Matching

A multi-winding transformer was connected to the output of the inverter to permit rapid matching of the inverter to any load condition. This transformer permitted adjustment of full output power from 15v to 400 v on the transmitting electrodes.

### 3.2.4 Complete Transmitter

The complete transmitter is shown in Figure 3.12, in block diagram form. A picture of the actual transmitter is shown in Figure 3.13.

## 3.3 Electrodes

The best electrode design could only be obtained from actual test. Electrodes were constructed from the following material.

- (a) Steel pipe, 3/4", 1", 1 1/4" and 1 1/2" dia. from 3 feet to 8 feet long.
- (b) Steel rod, 1/2" dia. from 2 feet to 5 feet.
- (c) Expanded metal steel sheet.

These electrodes were connected in various fashions depending upon the resistivity of the transmitting medium, as described in Section 4.



TRANSMITTER WITH VARIABLE POWER & FREQUENCY  
FIGURE 3.13

#### 4. Test Procedure and Results

The tests were conducted using a mobile transmitter and receiver. Usually the transmitter was mounted in the rear of a station wagon while the receiver was located in a test boat, laboratory or second vehicle. Portable gasoline driven 115v AC generators were used for the source of power when necessary.

Mobile radio communication was used in conducting the tests and greatly facilitated the recording of data. Copies of all the actual test data are included in the Appendix.

##### 4.1 Electrode Configuration

Tests were made to determine what orientation and configuration of electrodes would provide the best signal at the receiver.

##### 4.1.1 Tests in Soil

Tests were conducted at the Bergen County Park in Lyndhurst, New Jersey with the various arrangements of both the receiving and transmitting electrodes shown in Figure 4.1. The electrodes consisted of 1 1/2 inch pipe driven into the earth for a distance of 5 ft.. In the arrangement shown, Figure 4.1A, the electrode pairs were placed on a line perpendicular to the axis between the transmitter and the receiver. Figure 4.1B shows the electrodes positioned in line with the transmission axis. Figures 4.1C, 4.1D and 4.1E show one, two and three electrode pairs driven at a 30 degree angle to the earth in line with the transmission axis. The received signal, as a function of the transmitted power, is shown in Figure 4.2. At this location the maximum signal was received when the transmitting electrodes are positioned in accordance with Figure 4.1D or Figure 4.1E, and the receiver electrodes positioned in accordance with Figure 4.1C or Figure 4.1E.

In conducting these tests the receiver was mounted in the test boat which was moored on the bank of the Passaic River. The receiver cable was run ashore to the electrodes which were driven into the ground above the river bank. The transmitter and portable generator were mounted in the back of a station wagon which was set up at a distance of 700 yds. (640 meters).

Figure 4.3 is a map of the park where the tests were conducted. Figure 4.4 shows the test boat and the cable running ashore to the receiving electrodes. Figure 4.5 shows the transmitter mounted in the station wagon.

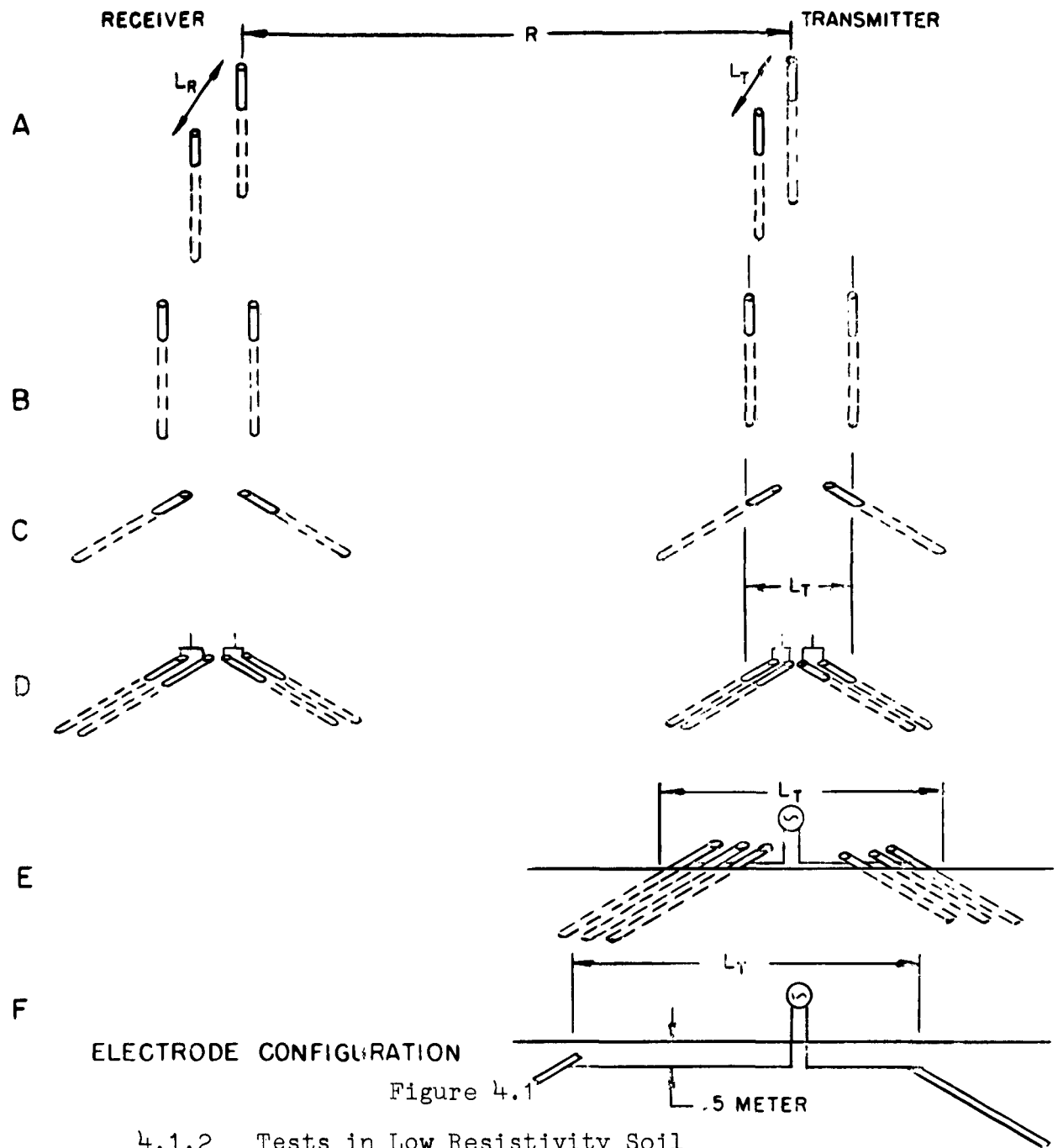

#### 4.1.2 Tests in Low Resistivity Soil

Further tests on the effect of electrode configuration were conducted at Island Beach State Park. This location was chosen because of the low noise level and low resistivity of the water laden soil. The configurations shown in Figure 4.1A, 4.1D and 4.1F were tested, and the results are plotted graphically in Figure 4.6. Figure 4.7 shows the installation of the antenna pic-

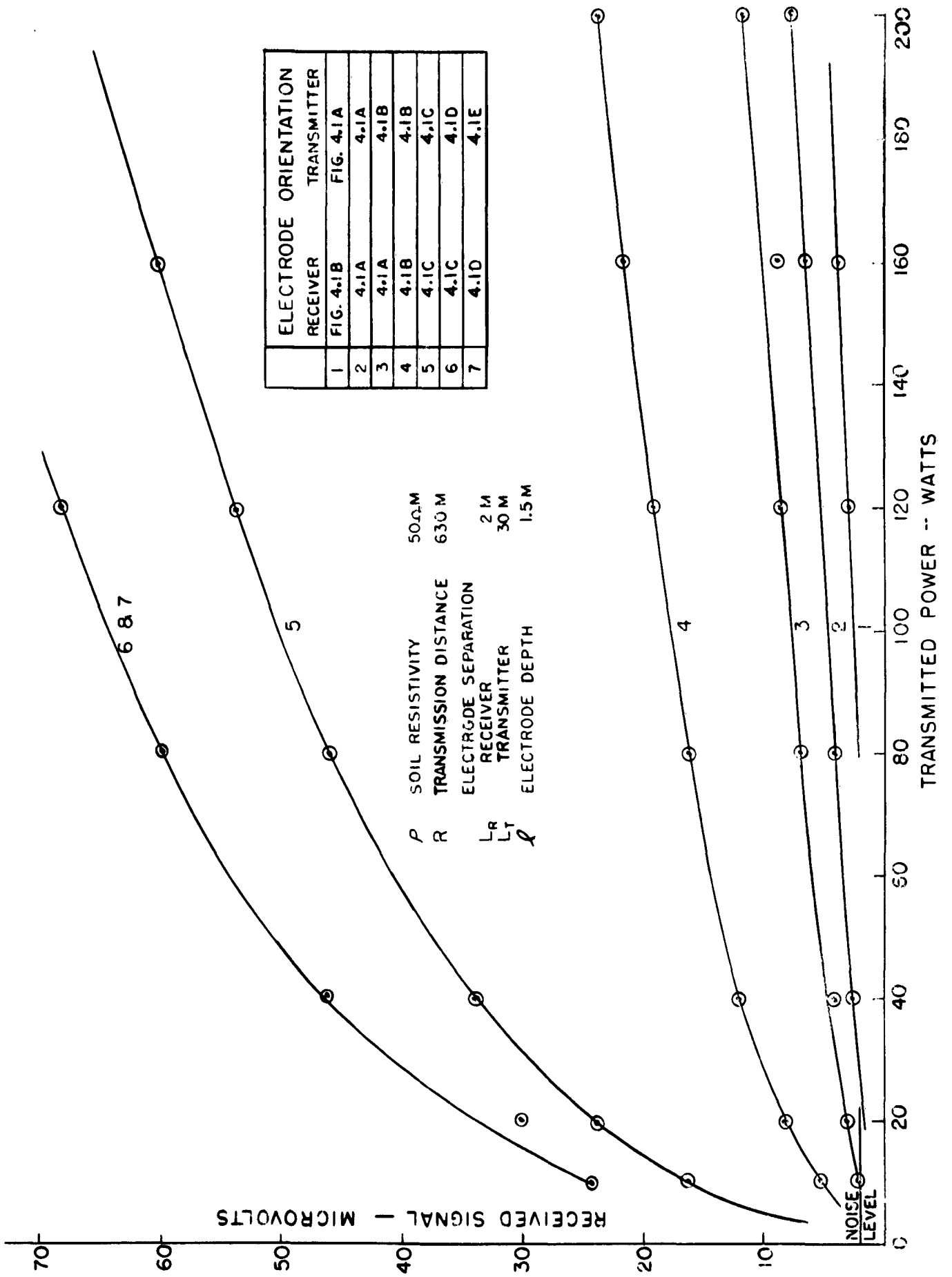
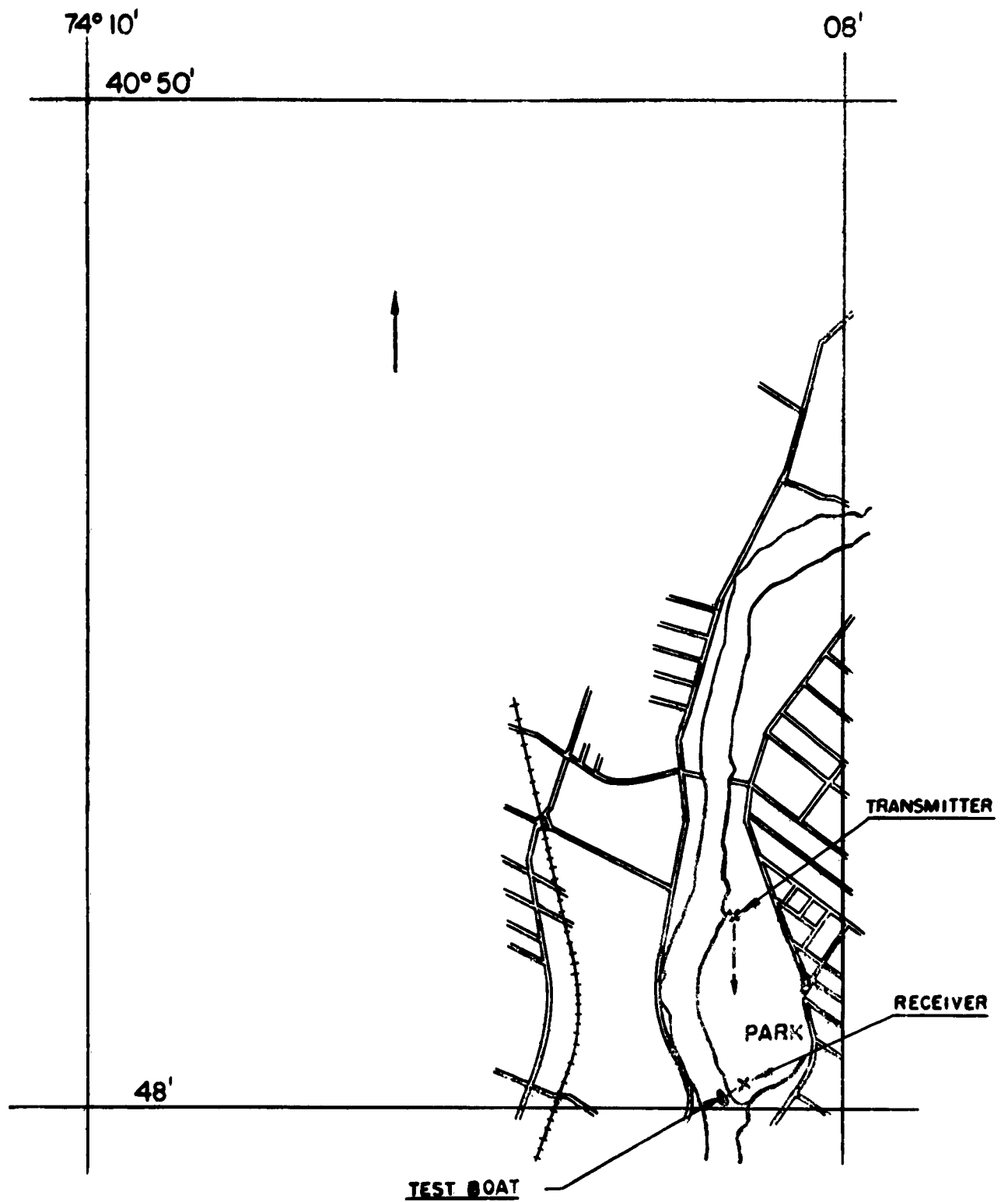

FIG. 4.2



SECTION OF U.S. COAST  
AND GEODETIC SURVEY MAP #287

FIG. 4.3



TEST BOAT  
FIGURE 4.4

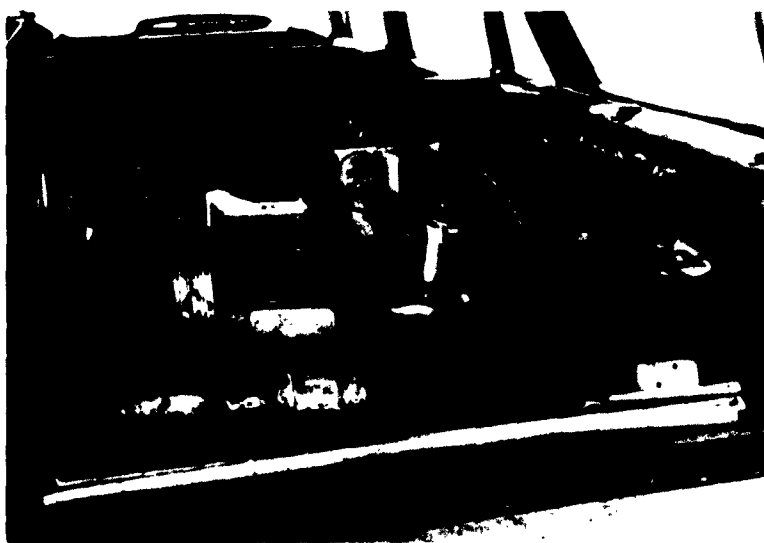

MOBILE TRANSMITTER  
FIGURE 4.5

tured in Figure 4.1F. In this test, conducted at 1 mile (1600 meters), there was no marked change in received signal with the different electrode configurations used.

#### 4.2 Effect of Resistivity

The effect of the resistivity of the transmitting media has been obtained for several locations over various distances.

##### 4.2.1 Determination of Soil Resistivity

The electrical ohmic resistance between two vertical rods driven into the surface of the earth has been determined theoretically to be:

$$R = \frac{\rho}{2l} \left( \log_{10} \frac{2l}{a} - 1 + \log_{10} \frac{l + \sqrt{S^2 + 2l^2}}{S} + \frac{S}{2l} \right) \quad (3)$$

where R is the terminal resistance in ohms,  $\rho$  is the soil resistivity in ohm-cm.  $l$  is the length of buried rod in cm.  $a$  is the radius of the rod in cm, S is the separation of the two rods in cm.

(Appendix Ref. 5).

This equation has been used to calculate the soil resistance in Figures 4.2, 4.6, 4.8 and subsequent graphs. The reciprocal of this value is the conductance ( $\sigma$ ) in mho per cm.

##### 4.2.2 Results

The graph, Figure 4.8, plotting the relationship between received signal and resistivity shows a fairly linear relationship over a short distance, however, at the greater distance there is insufficient data to determine whether the linear relationship is still valid.

#### 4.3 Signal vs. Antenna Length

Tests conducted at the Lyndhurst Park and other locations show that the received signal is related to the square root of the antenna length. Tests were conducted with 8, 20, 50 and 100 ft. antenna. Similar tests were conducted by varying the length of the receiving antenna,

	ELECTRODE RECEIVER	ORIENTATION TRANSMITTER
1	FIG. 4.1A	FIG. 4.1A
2	4.1D	4.1D
3	4.1C	4.1F
4	4.1C	4.1D

$\rho$  SOIL RESISTIVITY 5 $\Omega$ M  
R TRANSMISSION DISTANCE 1450M  
ELECTRODE SEPARATION  
 $L_R$  RECEIVER 15M  
 $L_T$  TRANSMITTER 30M  
 $\ell$  ELECTRODE DEPTH 2M

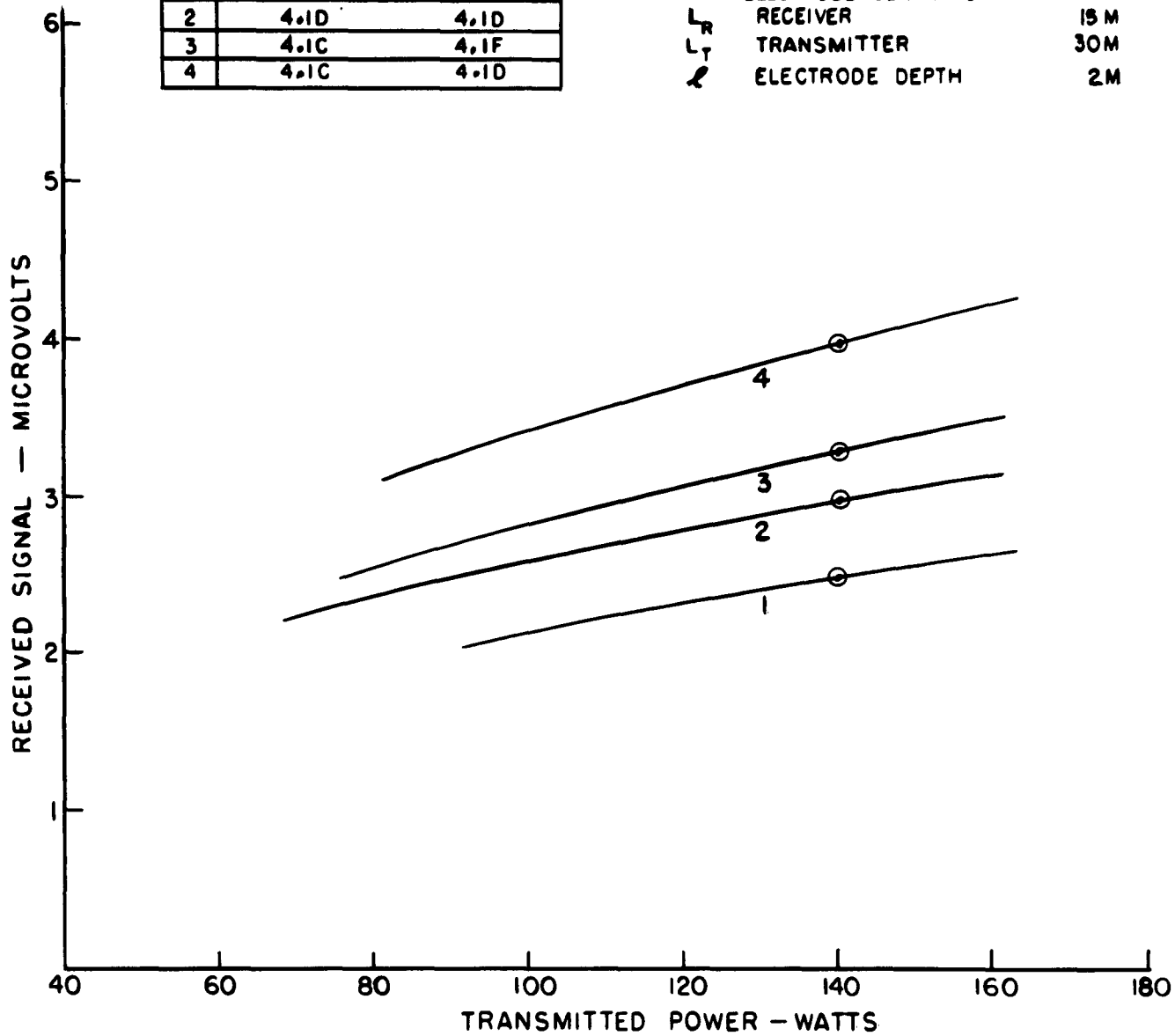
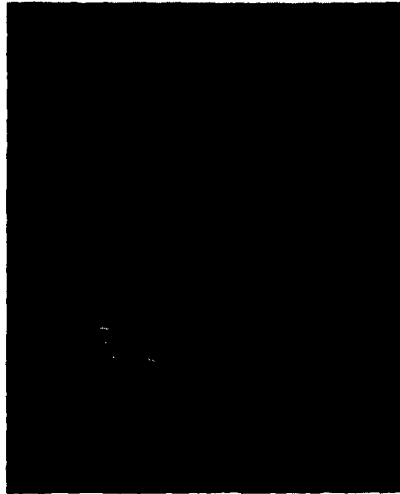

FIG. 4.6



PREPARATION OF TRANSMITTING ANTENNA 4.1F

FIGURE 4.7

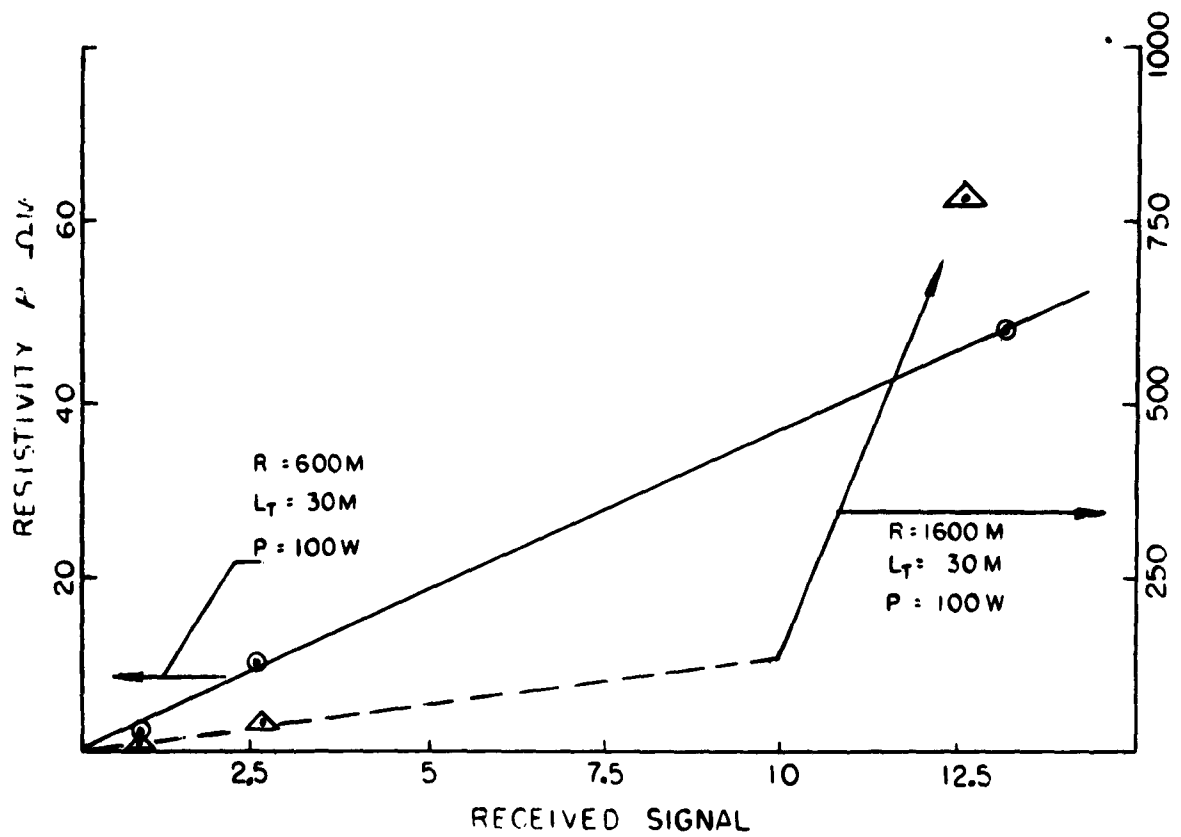

FIG. 4.8

and it was found that the received signal is a function of the square root of the length of the receiver antenna also. In locations where there was a large 60 cycle noise signal induced on the receiver, increasing the length of the receiver antenna did not improve the reception. This was caused by the nature of the transient response of the receiver, as shown in Figure 3.10. In nearly all the tests, there was a varying amplitude noise applied to the receiver and this noise had a varying 35 cycle component. The receiver output would fluctuate in a random fashion in response to this noise. Increasing the length of the receiver antenna increased the fluctuations along with the received signal and did not give an improved signal to noise ratio.

Figure 4.9 shows the change in received signal with changes in the length of receiving and transmitting antennas for two tests. Data taken for all the tests presented in the Appendix show the same relationship.

Therefore:

$$E_{rec} = \underline{F}, (\sqrt{L})$$

(4)

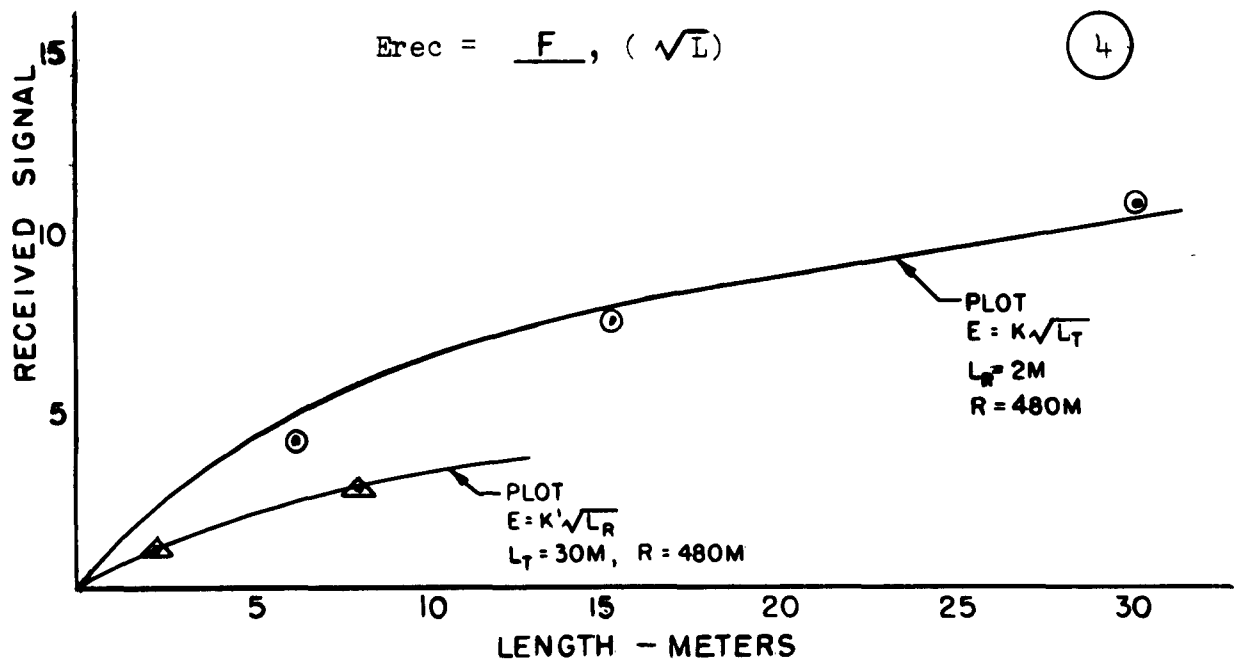

### SIGNAL vs ANTENNA LENGTH

Figure 4.9

#### 4.4 Signal vs. Power

As discovered in the Initial Evaluation (Section 2.5), the received signal is proportional to the square root of the transmitted power.

Subsequent tests (Figure 4.2) again show this relationship. All the tests conducted relate the received voltage to the transmitted power by the square root relationship.

$$E_{rec} = \underline{E}, (\sqrt{P})$$

5

#### 4.5 Signal Discrimination

As would be expected by the frequency response of the receiver, Figure 3.9, the response of the receiver in actual operation would not be any different. Actual tests were conducted at a transmission distance of 600 meters and the signal from the transmitter was changed to create the frequency response shown in Figure 4.10.

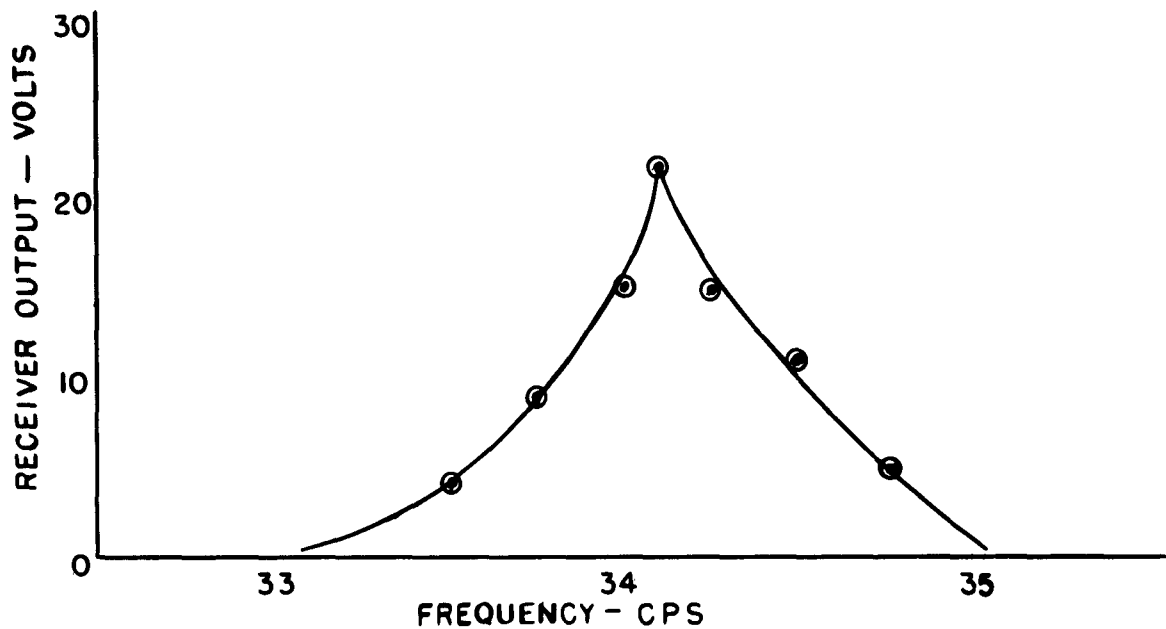

ACTUAL RECEIVER RESPONSE

Figure 4.10

At frequencies greater than 2 cycles away from the center frequency, the receiver has virtually no response.

#### 4.6 External Receiver Interference

As previously mentioned, the receiver used in these tests has a long transient response time (Figure 3.10), and is therefore affected by large amplitude noise at the input. Only on one occasion was it possible to observe the effect of lightning on the receiver and the transient observed in this case was the same as that produced by any other sudden change in input signal. In all the tests a signal with a 10 second duration was readily recognizable at the receiver output.

#### 4.7 Interference with ILS

Tests were conducted at the NAFEC facility at Atlantic City, New Jersey in order to determine the effect of this type of transmission on the ILS pattern.

The possible sources of interference could be created from two sources —

1. Electromagnetic radiation from the transmitting electrodes into the air.
2. Induced voltage into the control cables linking the ILS transmitter to the airport tower.

The localizer beam on runway 31 was selected as the most likely area where interference could be created. The glide slope transmitter utilizes mechanical modulation and would not be sensitive to any induced interference.

The oscillator powering the transmitter was taken to the localizer shack and aligned at 90 cycles with the oscillator in the localizer transmitter.

The transmitter was then set up at the localizer end of the runway with the transmitting electrodes arranged as shown in Figure 4.1A. Three pairs of electrodes were driven into the ground with their axis across the signal cable connecting the transmitter with the tower. This arrangement should produce the greatest amount of interference both radiated and induced.

A power of 140 watts at 400 volts and 90 cycles was impressed by the transmitter. No interference or pattern change was detected by the test aircraft.

Figure 4.11 is a map of the runway showing the transmitter location at point A. Subsequent tests were made at point B with a 35 cycle transmission frequency.

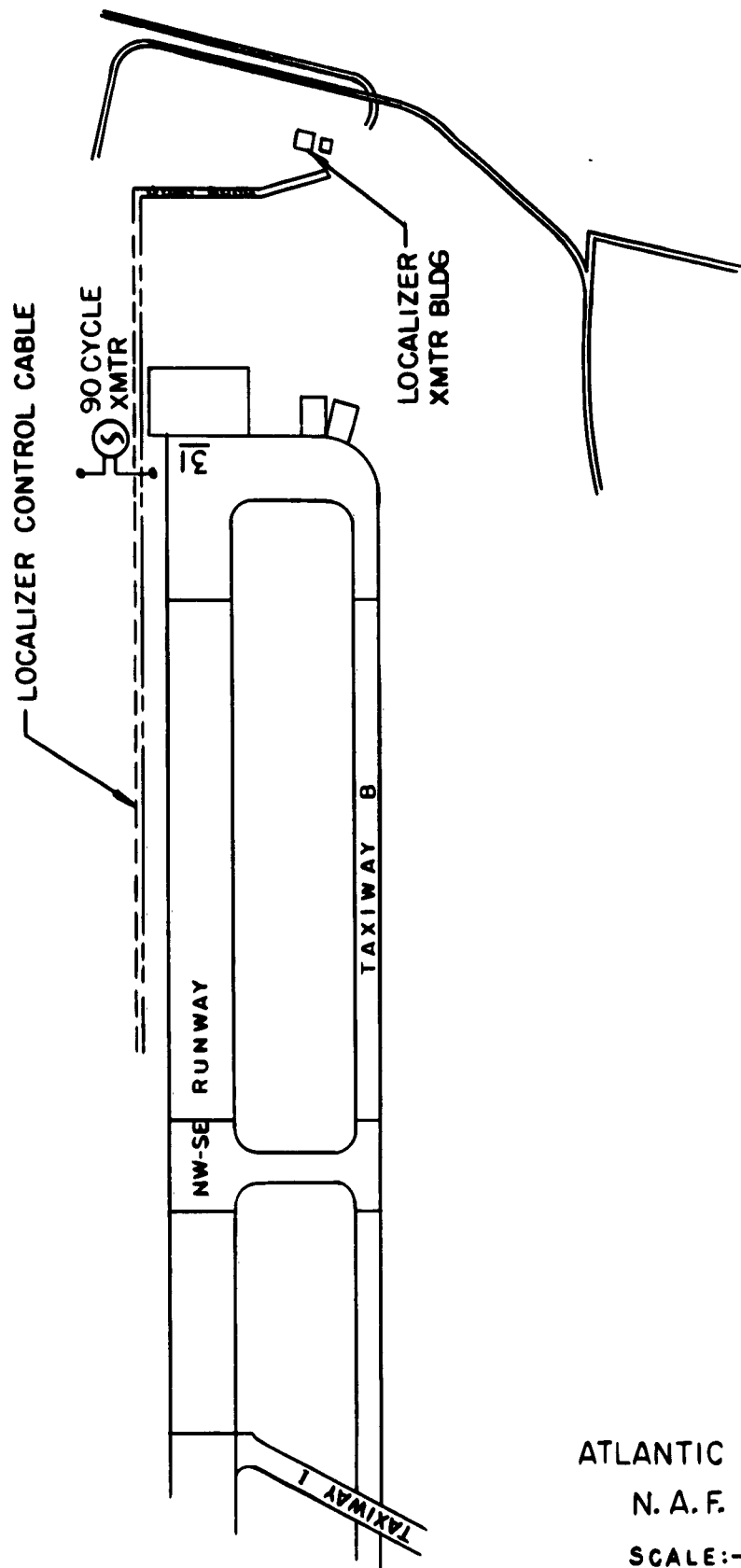

FIG. 4.11  
 4-12

ATLANTIC CITY, N. J.  
 N. A. F. E. C.

SCALE:- 500 FT./IN.

SECTION OF FAA DWG. #1-E-9990

#### 4.8 Signal vs. Distance

Tests were conducted to determine the relationship between the received signal and the distance between the transmitter and receiver.

The result of this test is shown in Figure 4.12. Contrary to the results obtained in the Initial Evaluation (Section 2.5), this test shows that the signal is attenuated by a factor of the reciprocal of the distance cubed.

$$E_{rec} = \frac{F}{R^3}, (1/R^3) \quad (6)$$

Other tests confirmed this relationship.

#### 4.9 Summary

Based upon the results established in equations 1, 4, 5 and 6, the received signal should be related to the transmission by the following equation:

$$E_{rec} = \frac{F}{R^3} \sqrt{\frac{PL}{f}} \quad (7)$$

Using the linear dependence upon soil resistivity, Section 4.2.2, Figure 4.8, the equation becomes:

$$E_{rec} = \frac{\rho K}{R^3} \sqrt{\frac{PL}{f}} \quad (8)$$

where  $\rho$  is the soil resistivity in ohm-meters -

$K$  is a constant transmission factor

$R$  is the transmission distance in meters

$P$  is the transmitted power in watts

$L$  is the length of the transmitting antenna in meters

$f$  is the frequency in cycles per second

$E_{rec}$  is the signal received on a receiving antenna 1 meter long (volts/meter)

Selected data taken from all the tests are consolidated and shown in Figure 4.13 by using equation 8.

The vertical axis was obtained by converting the received signal (in microvolts) to an equivalent one

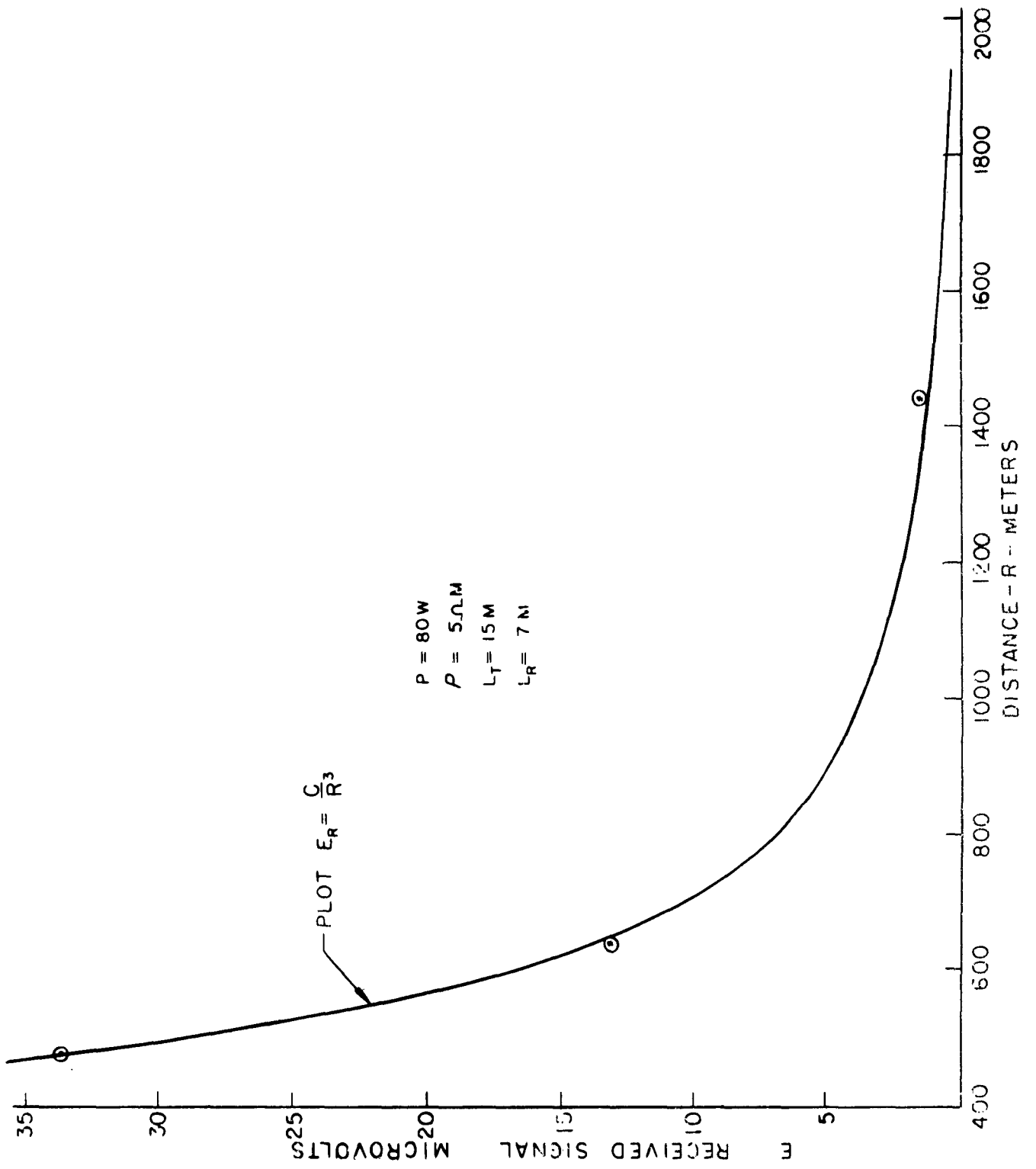

FIG. 4.12

meter antenna signal, divided by the resistivity of the media, and plotting this number in db.

Most of the data follows a straight line relationship except the data taken in salt water and in sand. In these cases a signal greater or less than that which should be expected was received. Apparently the resistance as measured at the transmitting electrodes was not the resistance of the overall media. In the case of the sea water test, 1.72 ohm-m resistivity, the signal could have traveled down to the bottom and then upward at the receiver. In the high resistivity earth, 800 ohm-m, the signal could have been shunted at some depth below the surface by a layer of low resistivity soil.

The values plotted in Figure 4.13 were taken when —

$$\sqrt{\frac{PL}{f}} = 9.25$$

This corresponds to a transmitted power of 100 watts (P) over an antenna 30 meters long (L) at a frequency of 35 cycles per second (f).

Drawing a straight line through these points gives a value of K equal to 32.5. Equation (8) now becomes:

$$E_{rec} = 32.5 \frac{\rho}{R^3} \sqrt{\frac{PL}{f}} \quad (9)$$

This equation is similar to equation (7) of our proposal (appendix Ref. 1)....

which is written as —

$$E'_{R_{MAX}} = \frac{\sqrt{PL\lambda}}{108\sigma r^3} \quad (10)$$

and can be changed to —

$$E'_{R_{MAX}} = 160 \frac{\rho}{R^3} \sqrt{\frac{PL}{f}} \quad (11)$$

by substituting

$$\lambda = c/f$$

where  $c$  is the speed of light

$$(3 \times 10^8 \text{ m/s})$$

and

$$\sigma = 1/\rho$$

Comparing equations 9 and 11, it can be seen that the theoretical maximum dipole efficiency was not realized by the antennas used in these tests. The experimental value of 32.5 was obtained rather than the theoretical value of 160.

Using the value of  $K$  determined experimentally, it is possible to extrapolate the results to higher powers and longer antennas.

A signal strength of -30 db is a reasonable signal strength at the receiver. This corresponds to a signal strength of 3 microvolt/meter in a soil of 100 ohm meter resistivity. If this signal is to exist at 3 miles (4800m), the line passing through this point, the value of  $\sqrt{PL/f}$  must equal 104. This corresponds to a power of 1000 watts at 35 cycles on an antenna 380 meters long.

Other tests were conducted from soil to water, but it was found that the introduction of a marked discontinuity in the transmitting media reduced the signal by a factor of 10 or 20. Similar reduction in signal was observed when the electrodes were placed on either side of a building which had a submerged support.

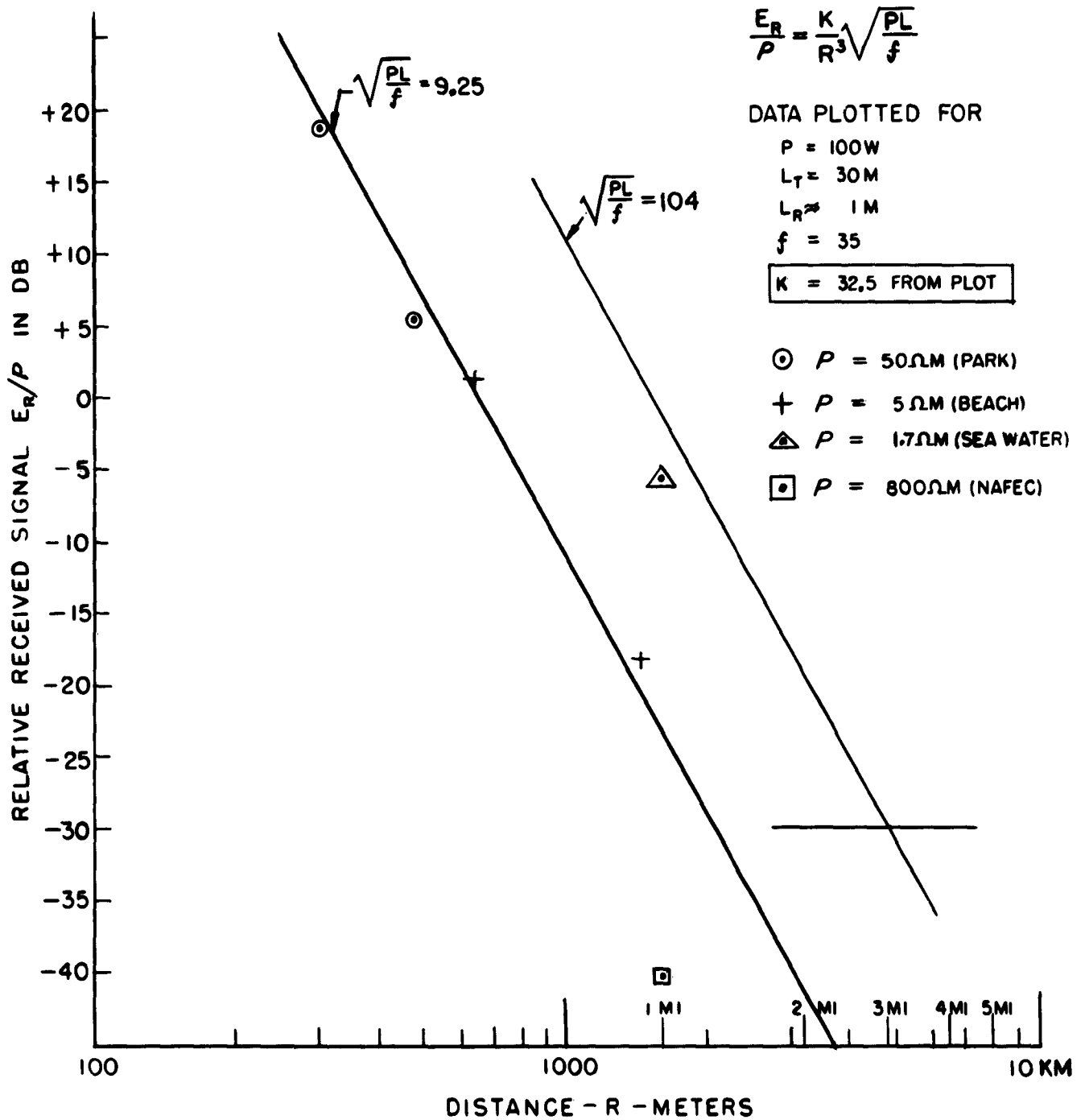

FIG. 4.13

5. Conclusions and Recommendations

The tests performed under this contract have established an equation relating the received signal, transmitted power and frequency, soil resistivity, antenna length and distance. In the tests conducted, transmission over distances up to 1 mile have been obtained.

Various factors affect the successful transmission of these signals and the following are of particular importance.

- (a) Placement of receiving and transmitting electrodes at a depth or orientation where surface discontinuities do not reduce the transmission.
- (b) Elimination of the effect of extraneous signals upon the receiver, in particular, 60 cycle signals.

The equation established by the tests conducted involves very large power and very long antenna for transmission at 5 miles, since the reduction of signal as a factor of  $1/R^3$  becomes great. It would seem likely that transmission at higher frequencies in the order of 2000 to 3000 cycles would offer more promise over greater distances since the antenna efficiencies are greater. Further work in this field should encompass the following factors:

- (a) Longer antenna - up to 500 meters
- (b) Higher power - up to 5000 watts
- (c) High frequencies - up to 3000 cycles
- (d) Antenna at greater depths

Useable signals at a distance of 5 miles would be readily obtained and the best economic configuration could be achieved.