

**UNCLASSIFIED**

---

---

**AD. 295 415**

*Reproduced  
by the*

**ARMED SERVICES TECHNICAL INFORMATION AGENCY  
ARLINGTON HALL STATION  
ARLINGTON 12, VIRGINIA**



---

---

**UNCLASSIFIED**

**NOTICE:** When government or other drawings, specifications or other data are used for any purpose other than in connection with a definitely related government procurement operation, the U. S. Government thereby incurs no responsibility, nor any obligation whatsoever; and the fact that the Government may have formulated, furnished, or in any way supplied the said drawings, specifications, or other data is not to be regarded by implication or otherwise as in any manner licensing the holder or any other person or corporation, or conveying any rights or permission to manufacture, use or sell any patented invention that may in any way be related thereto.

CATALOGED BY ASTIA

AS AD NO. —

295 415

295415

APGC-TDR-62-44



# Global Search and Recovery

## A Feasibility Study of Computer Simulation

by Russell Fanning

APGC Technical Documentary Report No. APGC-TDR-62-44

NOVEMBER 1962 • Project No. 7990  
3

**AIR PROVING GROUND CENTER**

AIR FORCE SYSTEMS COMMAND • UNITED STATES AIR FORCE

EGLIN AIR FORCE BASE, FLORIDA



ASTIA  
FEB 2 1963  
TISIA

Qualified requesters may obtain copies from ASTIA. Orders will be expedited if placed through the librarian or other person designated to request documents from ASTIA.

When US Government drawings, specifications, or other data are used for any purpose other than a definitely related government procurement operation, the government thereby incurs no responsibility nor any obligation whatsoever; and the fact that the government may have formulated, furnished, or in any way supplied the said drawings, specifications, or other data is not to be regarded by implication or otherwise, as in any manner licensing the holder or any other person or corporation, or conveying any rights or permission to manufacture, use, or sell any patented invention that may in any way be related thereto.

Do not return this copy. Retain or destroy.

## FOREWORD

This study was conducted under SSD 7993 - 17533, Search and Recovery Concepts, dated 17 August 1960. This task called for a study of the problem of search and recovery of both space vehicles and downed aircraft on a global basis. Another task, SR 7993 - 49759, Retrieval Concepts, covers similar requirements, and reports on various aspects of this task have been prepared by several contractors.

The author wishes to acknowledge the assistance of Mr. Harry Gaines who programmed this model for the IBM 7090 and was of constant aid in formulating the problem. Also, Mr. Gaines wrote much of those portions of the report dealing with the actual computer program. The aid and advice of Dr. John J. Murphy, who was the original project officer, is also gratefully acknowledged.

*Catalog cards with abstracts may be found at the back of this document.*

## ABSTRACT

The subject of computer simulation was chosen for this feasibility study as this aspect does not appear to have been well covered during previous studies of the Global Search and Recovery problem.

A mathematical model was constructed of a simulated search and recovery mission, and a computer program was constructed which embodied this model. The objective of this computer program was the determination of the probability of successfully retrieving a downed object when given information as to the probable location, the nature and deployment of search and recovery facilities, and a geographic and political description of the earth. Considerable attention was given to developing a convenient means of entering and varying the parameters of the model in a systematic manner.

The results of this study indicate that it would be feasible to construct a computer model of at least certain aspects of the search and recovery problem which would be suitable for studies of the effects of several parameters. However, the model described is believed to be too limited and inflexible in form (though not in parameter values) to permit generalization to a larger variety of search and recovery problems. Future work along this line should probably employ a Monte Carlo type approach.

### **PUBLICATION REVIEW**

*This technical documentary report has been reviewed and is approved.*

  
A. T. CULBERTSON  
Brigadier General, USAF  
Vice Commander

## CONTENTS

Section	Page
1. INTRODUCTION .....	1
2. DESCRIPTION OF PARAMETERS .....	2
Factors Which Influence the Probability of Successful Rescue .....	2
Parameters and Tables .....	3
Calculation of a Case .....	7
Initial Introduction of Parameter Values .....	7
Variation of Parameters for a Group of Cases .....	8
Calling for Calculation of an Experiment .....	8
Output .....	9
3. MATHEMATICS OF THE MODEL .....	9
Overall Equation for Probability of Retrieval .....	9
Distance Formula .....	11
Search Calculations .....	16
4. DESCRIPTION OF COMPUTER PROGRAM .....	21
Size and Speed of Computer Program .....	21
Duplication of Certain Tables .....	23
Main Program .....	23
Computer Block .....	25
5. DISCUSSION OF RESULTS .....	30
6. CONCLUSIONS .....	31
BIBLIOGRAPHY .....	32
 Appendix	
I. FACTORIAL EXPERIMENTS .....	33
II. INPUT CARD FORMATS AND AUXILIARY TABLE VAL- UES .....	38

## ILLUSTRATIONS

Figure	
1. Spherical Triangles, Showing Notations .....	12
2. Unit Vectors Used in Vector Algebra Solution .....	15
3. Search Pattern Used in Model .....	16
4. Spherical Triangle Used for Finding Point A .....	19
5. Flow Chart for Overall Program .....	22
6. Flow Chart of Computation Block .....	26

## SECTION 1 - INTRODUCTION

The investigation of one aspect of the search and recovery task, that of a computer model, was not attempted during previous studies. Since this aspect was suggested as a desired goal by Air Rescue Service, such a computer model was made the subject of the study covered in this report. In devising the model described, full use was made of reports in the retrieval concepts area (SR 49759) made to the Aeronautical Systems Division by contractors. Without such information, the study covered in this report would have had little relationship to the actual problem.

Since no previous models applicable to this problem could be found, the initial phases of this study were devoted to determining the various aspects of the problem and their application to a high speed computer program. Considerable thought was devoted to determining the variables involved and to how they might be numerically specified. In particular, the problem of specifying the pertinent variables for the surface of the earth, on a global scale, was most difficult. Also various basic assumptions had to be made, for example, the viability of a person or object was assumed, consistent with previous limited information, to be a negative exponential, with one exponent up to time of finding and another exponent from time of finding to time of retrieval. Such assumptions cannot be considered completely accurate, but it is believed that they are reasonable and not grossly incorrect.

The specific search and recovery tactics to be employed also cannot be positively determined; however, these need be only approximations having the essential characteristics of an actual search and recovery. The search tactics are considered to consist of a dash by the search vehicle directly to the most probable location of the object, and then a spiral search about this point. Similarly, the retrieval tactics are considered to consist of a dash by the retrieval vehicle (possibly a ship) toward the most probable position, then a change of course, at the time the object is sighted, toward the point at which retrieval can be accomplished.

The computer model which will be described represents an attempt to introduce the variables in a quantitative manner so that a quantitative value of the probability of retrieval for any given situation can be found,

and more important, the effects of variations in the situation can be conveniently studied.

In order to study the problems involved in mechanizing the model, the programming work was actually carried out. In addition, considerable effort was spent in investigating the possibilities and difficulties of varying almost any of the parameters in a factorial manner.

## SECTION 2 - DESCRIPTION OF PARAMETERS AND VARIATIONS TO PARAMETERS

### FACTORS WHICH INFLUENCE THE PROBABILITY OF SUCCESSFUL RESCUE

The study of previous efforts in this field revealed that there are a number of factors which are variable and which greatly influence the probability of a successful retrieval. Some of the most important are described in the following paragraphs. In the remainder of this report, we will refer to specific parameters. It should be kept in mind, however, that these parameters are formalized embodiments of the variables discussed below, and that one of these parameters may represent the combined effects of several physical agencies, devices, or variables of the real problem. Thus, if a given parameter shows up as crucial, the means of obtaining a better value for this parameter may require further study. A model such as that described here can only point to the crucial parameters for a given problem.

**SIZE OF AREA TO BE SEARCHED.** The size of the area to be searched may vary from a few square miles to tens of thousands of square miles. The importance of this factor is obvious, but quantitative studies are considered to be helpful.

**WIDTH OF PATH WHICH MAY BE SEARCHED BY SEARCH VEHICLE.** The width of the path which may be searched by the search vehicle may vary from a few feet to a few miles for a visual search, as to a large extent, visual search is affected by weather conditions. If electronic devices are used with a cooperating object, the width of the path may be as great as several hundred miles.

**RANGE AND ENDURANCE OF SEARCH AND RECOVERY VEHICLES.** Range and endurance are controlling factors for long range searches, and

design specifications for vehicles depend on the values required. For example, helicopters usually cannot be used for long range searches, while ships perform well with regards to range and endurance.

**TYPE OF RECOVERY VEHICLE.** The possibility exists that recovery can be accomplished by the search vehicle, for example, both search and recovery may be possible by an aircraft which can hover. In other cases, separate vehicles may be required for search and recovery. This problem has led to many differing proposals, such as the "Mother-Daughter" system, large VERTOL search aircraft and pick-up by "Long Line" techniques.

**POLITICAL SITUATION IN SEARCHED AREA.** The political situation in the area of probable location, as it affects the search and the possibility of retrieval, is a variable which realism requires to be considered.

**PROBABILITY OF SAFE LANDING.** The probability of the downed object landing safely in the area enters into a decision for the type of retrieval.

**EFFECTS OF CLIMATIC OR GEOGRAPHICAL CONDITIONS ON VIABILITY.** The severity of climatic or geographical conditions in the region, as it affects the chance of living until recovery, is an important factor in planning the rescue. Clearly, a person overboard in the North Atlantic must be rescued sooner than one in more moderate temperature regions.

**TIME REQUIRED TO LOCATE AND RETRIEVE.** The time required to locate and retrieve a downed object or person has a major influence on the success of a retrieval, especially when climatic or geographical conditions are severe. Such factors as speed and scramble time of search and recovery vehicles play a part in determining the time of finding and retrieval. The location of bases and the characteristics of the search and recovery vehicles stationed at each base must also be considered.

#### PARAMETERS AND TABLES

The number of parameter values necessary to describe the problem configuration by use of this model is very large, approximately 25,000. It was clear, therefore, that some convenient method was necessary to introduce these values into the computer and vary them during an experiment. The parameters fall rather naturally into a small number of

groups. These groups were arranged in tables, and the tables were arranged in a systematic way and given names descriptive of the parameters they contain.

The major groups of parameters are those that describe:

1. The topographical and political features of the surface of the earth.
2. The nature and deployment of search and recovery facilities.
3. The probable location of the object of search and recovery.
4. The method of search and recovery to be used.

**TOPOGRAPHICAL AND POLITICAL FEATURES.** The group containing the topographical and political features consists of three tables, GLOBE, PROB, and VIAB. These tables are referred to as permanent tables since they contain information which is less variable than that contained in the other tables.

**GLOBE Table.** The GLOBE table contains the description of the surface of the earth. The earth's surface was divided into sectors bounded on the east and west by parallels of longitude which were 4 degrees apart and on the north and south by circles of latitude chosen so that all the sectors had an equal area. Forty-four circles of latitude were used together with the poles so that there were 4050 (45 x 90) sectors. These sectors are indexed with two indices,  $i$  and  $j$ . The  $ij^{\text{th}}$  sector is the  $i^{\text{th}}$  sector south from the North Pole and the  $j^{\text{th}}$  sector east from the Greenwich meridian.

Six quantities were used to describe each sector:

1. Topography.
2. Country.
3. Probability of safe landing.
4. Political probability of retrieval.
5. Viability up to time of finding.
6. Viability from finding to retrieval.

Item 1 was included to enable statistics on these features of the terrain to be obtained.

Item 2 was intended to provide a means of changing item 4 for all sectors belonging to a given country. This item is not in the program as it now stands.

Items 3 through 6 were used in the calculation of the probabilities.

Thus, when using this model, 24,300 (6 x 4050) parameter values are needed to describe the surface of the earth. Since only 32,768 words of storage are available in memory, this information is packed, that is, all six items pertaining to a sector are stored in one word and there is one word for each sector. Because this packing limits the space available for these items, most are not stored directly, but rather an index referring to them is stored. Thus, if item 5 is 14, this means that the first viability parameter for that sector is the 14<sup>th</sup> value in the list of viability values.

PROB Table. PROB is a table of 32 selected values to be used as probabilities. Items 3 and 4 of the GLOBE word are indices referring to PROB.

VIAB Table. VIAB is a table of 128 selected values to be used as viability parameters. Items 5 and 6 of the GLOBE table are indices referring to VIAB.

**SEARCH AND RECOVERY FACILITIES.** The parameters of the second group, those describing the search and recovery facilities, are contained in the SBASE and RBASE tables.

The SBASE table contains the description of up to 50 search bases. For each search base, the following information is specified:

1. Number of vehicles available.
2. Velocity of vehicles.
3. Latitude of base.
4. Longitude of base.
5. Scramble time of vehicles.
6. Endurance time of vehicles.

7. Probability of detection of the object.
8. Sweep width of vehicle.

These parameters are double indexed, the  $ij^{\text{th}}$  entry in SBASE table being the  $j^{\text{th}}$  item referring to the  $i^{\text{th}}$  base.

The RBASE table contains the description of the retrieval bases and is identical in format to SBASE, with the exception that items 7 and 8 do not appear since they are inapplicable to a retrieval vehicle.

**PROBABLE LOCATION OF OBJECT.** The parameters of the third group, those describing the probable location of the object, are stored in the OBJ table. This table has only three entries:

1. The latitude of the mean point of impact (MPI).
2. The longitude of the MPI.
3. The value of the circular probable error (CEP).

**METHOD OF SEARCH AND RECOVERY.** The parameters of the last group, those used to designate the method of search and recovery to be used, consist simply of two numbers. These two numbers are kept in two storage cells called respectively SDOCT, for search doctrine, and RDOCT, for retrieval doctrine. For uniformity of nomenclature, these are also called tables.

The only flexibility in the search doctrine is the manner in which the search is selected. This can be done in one of four ways:

1. Choose the base nearest the MPI.
2. Choose the base whose vehicle can first arrive at the MPI.
3. Choose the base whose vehicle can search longest after arrival at the MPI.
4. Choose the base whose vehicle can search the largest area after arrival at the MPI.

The code number stored in SDOCT will determine which of the above methods will be used.

The only flexibility in the doctrine of retrieval is the choice of whether:

1. The search vehicle also retrieves; therefore, no retrieval bases are involved.

2. The search vehicle does not retrieve; therefore, a retrieval base must be chosen (always the closest).

The code number stored in RDOCT determines which retrieval doctrine will be used.

Note: When the actual computer program is described, it will be found that for technical reasons certain of the tables are duplicated. This need not be considered at this time as this duplication was necessary only to permit factorial experiments to be run.

#### CALCULATION OF A CASE

A single case, or simulated mission, consists of the calculation of the probability of successfully retrieving a downed object, given information as to the probable location, the nature and deployment of search and retrieval facilities, and the geographic and political conditions of the area.

The method of performing this calculation is to generate a series of representative locations (points) where the object might be and to calculate the probability of its being successfully retrieved from each of these points. A weighted average of the probabilities is then calculated, the weights being taken as the probability that the object is actually in the area represented by the points. The probability density function of the object sought is taken to be circular binormal, the MPI and CEP being furnished. The representative points are generated so as to be equally spaced in angle on concentric circles centered about the MPI. Eight points are generated for each circle.

#### INITIAL INTRODUCTION OF PARAMETER VALUES

The parameters are introduced by punched cards called SETUP cards. These cards are identified by the word SETUP in columns 1 through 5 and contain in general:

1. The name of the table to be set up beginning in column 13.
2. Indices of flags denoting which part of the table is to be set up.

3. The value or values to be inserted.

For details of the format of these cards see Appendix II.

The parameter values so introduced are the original values for each experiment. After being introduced, they are subject to variation.

VARIATION OF PARAMETERS FOR A GROUP OF CASES (OR EXPERIMENT)

It is believed that a "factorial experiment" is a desirable and convenient way of systematically investigating the separate as well as combined effect of a whole pattern of changes in pertinent parameters. Such factorial variation of parameters is specified by use of FACTOR cards. The use of this feature of the program is not mandatory, and in the event only one case is desired and the original values are to be as set up, the only card required is a FACTOR RESET card. Otherwise a number of FACTOR cards may be employed.

See Appendix I for a discussion of a factorial experiment. The format of FACTOR cards is described in Appendix II.

CALLING FOR CALCULATION OF AN EXPERIMENT

A card, punched GOGO in columns 1 through 4, is used as a signal that the setup of an experiment is complete and the calculation is to begin.

To summarize, an experiment is performed by:

1. Entering a basic set of parameters by means of SET and/or LOAD cards.
2. Entering information as to how this basic set is to be varied during the experiment by means of FACTOR cards (this includes no variation, which is specified by a FACTOR RESET card).
3. Calling for execution by means of a GOGO card.

This results in calculation of all cases specified by the factorial experiment setup. Further experiments may now, if desired, be set up and run during the same machine run.

OUTPUT

For a sample output see Appendix II.

SECTION 3 - MATHEMATICS OF THE MODEL

OVERALL EQUATION FOR PROBABILITY OF RETRIEVAL

Let

P = overall probability of successful retrieval for a mission.

Then

$$P = \sum_N \sum_M \Delta P(N, M)$$

where

$\Delta P(N, M)$  = incremental probability of successful retrieval from the area (segment of a ring) having its center at the M<sup>th</sup> angular position ( $\theta = \theta_M$ ) on the N<sup>th</sup> radius ( $R = R_N$ ).

The N and M loops in the computer program are correspondingly named, and carry out the determination of these incremental probabilities, from the basic relationship

$$\Delta P(N, M) = P_A P_{DET} P_{SL} P_L P_{POL}$$

where:

$P_A$  = probability of downed object landing in the area.

$P_{DET}$  = probability of detection by search vehicle, if in area searched.

$P_{SL}$  = probability of safe landing of downed object.

$P_L$  = probability of survival (living until retrieved) if landing was safe.

$P_{POL}$  = political probability of retrieval being permitted.

Further let:

$t$  = time after impact, running variable.

$T_{SCR, S}$  = scramble time for search vehicle.

$T_{SCR, R}$  = scramble time for retrieval vehicle.

$T_{END, S}$  = endurance time of search vehicle.

$T_{END, R}$  = endurance time of retrieval vehicle.

$T_F$  = time of finding (time search vehicle will reach the area).

$T_T$  = total time to retrieval for that area.

$V_S$  = speed of search vehicle.

$V_R$  = speed of retrieval vehicle.

$W$  = width searched on either side of vehicle's path, i. e., the search half-width.

$T_{L1}$  = viability time for downed airman (or object) up to time of finding.

$T_{L2}$  = viability time from finding until retrieval.

In this model, we consider that  $P_{DET}$  is a direct function only of the search base from which the search vehicle leaves, i. e., we specify the parameters of a vehicle through its base, of which we consider it to form a part. The same is true of  $W$ .

The probabilities  $P_{SL}$  and  $P_{POL}$  are direct functions of the territory where the object is downed, i. e., of the global sector involved.

$P_A$  is a direct function of the statistical location of the object with respect to the MPI, and also indirectly of the parameter  $W$  (search half-width) which is a function of the search base (since this includes the search vehicle, as noted above).

The remaining probability,  $P_L$ , is a direct function of the parameters  $T_{L1}$  and  $T_{L2}$  which are characteristics of the global sector.  $P_L$  is also a

function of the times of finding and retrieval since, assuming as convenient and plausible that the probability of remaining alive (the viability of the object) falls off exponentially with time, we have

$$P_L = e^{-T_F/T_{L1}} \times e^{-(T_F - T_T)/T_{L2}}$$

The calculation of  $T_F$  and  $T_T$  is an essential problem and will require all the remaining parameters, as well as several of those also entering into the determination of other probabilities.

Note that  $P_{DET}$  has been specified as a function of search base (vehicle) alone, although it depends, as does  $W$ , on the characteristics of the downed object. To attempt to include explicit dependence on the object in the model appears unnecessarily complicated for the present purpose.

It should also be noted that the possible delays in starting search or retrieval have been considered as the respective scramble times, and that the endurance times of the vehicles have been specified directly instead of as ranges.

Since the search and recovery model is, by definition, global in scope, the calculation of positions, distances, angles, etc., must be by a method suitable for such a problem. Therefore, we consider the earth to be spherical and specify all positions by latitude and longitude and all distances in nautical miles. All paths of vehicles are taken as along great circles, and the methods of spherical trigonometry were originally employed. A nautical mile is taken to be the length of one minute of arc along the equator.

#### DISTANCE FORMULA

For the distance (Dist) between two points we use, in most cases, the cosine law for sides from spherical trigonometry: \*

$$\text{Dist} = c = \cos^{-1} (\cos a \cos b + \sin a \sin b \sin C).$$

We always take this distance as positive, and between 0 and  $\pi$  radians inclusive, so that no ambiguity results. We use this formula, for example, in choosing bases, since any of the criteria call for comparing

\*It actually proved more desirable in some situations to employ the methods of vector algebra to avoid difficulties with special cases.



First, in large triangle BXP, we have given:

$a_1$  = colatitude (colat) of B, i. e., of retrieval base

$c_1$  = distance from retrieval base to MPI

$b$  = colatitude of X, i. e., of MPI

$\angle C_1$  = longitude (long) of B - longitude of X

and we want

$$\angle A = \angle BXP.$$

We first put

$$s_1 = \frac{1}{2} (a_1 + b + c_1).$$

Then from the tan of half-angle law,

$$\angle A = 2 \tan^{-1} \sqrt{\frac{\sin(s_1 - b) \sin(s_1 - c_1)}{\sin(s_1 - a) \sin s_1}}.$$

Second, in smaller triangle FXP, we have given:

$$\begin{array}{l} \angle A \\ c_2 = c_1 - V_R \left( T_F - T_{SCR, R} \right) \\ b \end{array}$$

and we want

$$\angle C_2 = \Delta \text{ long of F}$$

$$a_2 = \text{colat of F.}$$

Again defining

$$s_2 = \frac{1}{2} (a_2 + b + c_2)$$

we have

$$\angle C_2 = 2 \tan^{-1} \sqrt{\frac{\sin(s_2 - b) \sin(s_2 - a)}{\sin(s_2 - c_2) \sin s_2}}$$

with sign of  $\angle C_1$ .

Then

$$\text{colatitude of } F = a_2$$

$$\text{longitude of } F = (\text{longitude of } X + \angle C_2) \text{ Mod } 2\pi.$$

This equation holds, however, only when none of the terms in the denominator vanish. These cases require special treatment. There are so many possibilities that the program becomes inelegant - it is too complicated for proper checkout of each case. Clearly this method introduces artificial singularities which need not occur.

**SOLUTION BY VECTOR ALGEBRA.** In place of the previous notation, we shall now define the unit vectors  $\hat{X}$ ,  $\hat{B}$ ,  $\hat{F}$ ,  $\hat{N}$  whose origins are at the center of the earth and whose termini define the points X, B, F, and N (North Pole) on the unit sphere (see Fig. 2). We now know that vector  $\hat{F}$  lies in the plane of  $\hat{X}$  and  $\hat{B}$ , thus in general, it is true that

$$\hat{F} = \alpha \hat{X} + \beta \hat{B} + \gamma (\hat{X} \times \hat{B}).$$

But, since in this problem,  $\hat{X}$ ,  $\hat{B}$ , and  $\hat{F}$  are coplanar,

$$\hat{F} = \alpha \hat{X} + \beta \hat{B}$$

i. e., there is no term in  $(\hat{X} \times \hat{B})$ .

Note that we shall denote the "cross" or vector product as  $(X \times B)$  and the "dot" or scalar product by  $(X \cdot B)$ .

We also know

$$\hat{F} \cdot \hat{B} = \cos [V_R^T_{BF}]$$

$$\hat{F} \cdot \hat{X} = \cos [\text{Dist (B to X)} - \cos (V_R^T_{BF})]$$

$$\hat{B} \cdot \hat{X} = \cos [\text{Dist (B to X)}].$$

Then, on forming these products and solving for the scalar coefficients  $\alpha$  and  $\beta$ , we find

$$\alpha = \frac{\hat{F} \cdot \hat{X} - (\hat{B} \cdot \hat{X})(\hat{F} \cdot \hat{B})}{D}$$

$$\beta = \frac{\hat{F} \cdot \hat{B} - (\hat{F} \cdot \hat{X})(\hat{B} \cdot \hat{X})}{D}$$

where

$$D = 1 - (\vec{B} \cdot \vec{X})^2.$$

Then, in the general case

$$\text{colat } F = \cos^{-1} [a \cos (\text{colat } X) + \beta \cos (\text{colat } B)]$$

and

$$\text{long } F = \tan^{-1} [a \sin (\text{colat } X) \sin (\text{long } X) + \beta \sin (\text{colat } B) \cos (\text{long } B)].$$



N = North Pole

Fig. 2: Unit Vectors Used in Vector Algebra Solution.

The only situations in which this general formula cannot be used, are those where  $D = 0$ , i. e., where  $\vec{B} \cdot \vec{X} = \pm 1$ . This can only occur for  $X = +B$  and  $X = -B$ , i. e., when the points  $X$  and  $B$  coincide, and when they are at opposite diameters of the earth, respectively. The first case is trivial; the second allows  $\vec{F}$  to be on any great circle through  $X$  and  $B$ , or any plane through  $\vec{X}$  and  $\vec{B}$  as we express it in this solution. For our problem, we may pick a plane arbitrarily and do so by imposing some further condition. Therefore, in this case, we assume that the path passes over the North or South Pole. This then also determines a rather special situation, and the appropriate formulas are easily written.

SEARCH CALCULATIONS

The basic search pattern which was originally contemplated was a spiral of Archimedes, with turns spaced by  $2W$ , i. e.,

$$R = \frac{W}{\pi} \theta$$

where  $R$  = radius from MFI,  $\theta$  = angle from north clockwise, and  $W$  = sweep half-width.

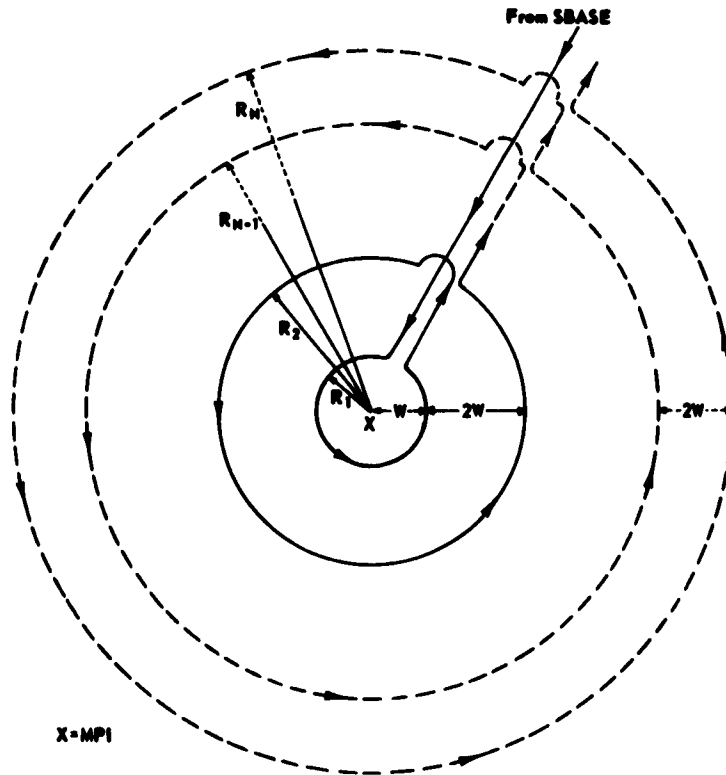

Fig. 3: Search Pattern Used in Model.

In actually constructing a model to be mechanized, it was found more convenient to assume a search by concentric circles (see Fig. 3), since the area searched in a given time is essentially the same and the computations are simpler.

We assume, therefore, that the search vehicle proceeds from its base directly toward the MFI of the downed object, but upon approaching to within a distance  $W$ , turns and makes a circle about the MPI at a radius of  $W$ , then goes out radially to the next radius which is  $2W$  greater, makes that circle, etc. On each circle, we choose eight points at angles of  $\pi/4$  to each other, each serving as a representative sample of the global characteristics in its general area. Therefore, we find its coordinates and then extract the parameters pertinent to our problem to calculate the incremental probability for that area.

**COORDINATES OF CENTERS (A) OF AREAS SEARCHED.** To calculate the coordinates of the centers (A) of the areas searched, we find points about the MFI, on successive radii  $R_N$ , at angles  $\theta_M$  from north.

Thus

$$R_N = R_{N-1} + 2W$$

where

$$R_1 = W \text{ or } R_0 = -W$$

and

$$\theta_N = \theta_{N-1} - \frac{\pi}{4}$$

where

$$\theta_1 = -\frac{\pi}{20} \text{ or } \theta_0 = \frac{\pi}{5}.$$

This value of  $\theta_0$  was chosen so that  $R_N$  will never pass through the pole, unless the MFI is at a pole, which situation we treat separately. In general (see Fig. 4), if given

$\theta$ ,  $R$ , and  $a$ ,

we find

$$c = \cos^{-1} \left[ \cos a \cos r + \sin a \sin r \cos v \right].$$

Then defining

$$s = \frac{1}{2} (a+r+c)$$

we have

$$\Delta L = 2 \tan^{-1} \sqrt{\frac{\sin(s-a) \sin(s-c)}{\sin(s-r) \sin s}}$$

with the sign of  $(\pi-\theta)$ .

The longitude  $A =$  longitude  $X + \Delta L$  colatitude  $A = c$ .

The only special cases are for  $X$  (the object) at the pole, and these are treated appropriately.

The area probability is defined as the probability of the downed object lying within one of the eight sectors of the ring bounded for  $R = R_N$  by the concentric circles of radii  $R_N+W$  and  $R_N-W$ .

We find the probability of the object lying in this ring as the probability of lying within the outer disk of radius  $(R_N+W)$  minus the probability of lying within the inner disk of radius  $(R_N-W)$ . Thus defining the outer disk probability (Prob) as

$$\text{Disk Prob}_N = 1 - e^{-\frac{1}{2} \left( \frac{R_N+W}{\sigma} \right)^2}$$

and the inner disk probability as

$$\text{Inner Disk Prob} = 1 - e^{-\frac{1}{2} \left( \frac{R_N-W}{\sigma} \right)^2}$$

we have

$$\text{Ring Prob}_N = \text{Disk Prob}_N - \text{Inner Disk Prob}_N.$$

But, by our iteration law

$$R_N - W = R_{N-1} + 2W - W = R_{N-1} + W$$

whence

$$\text{Inner Disk Prob}_N = \text{Disk Prob}_{N-1}$$

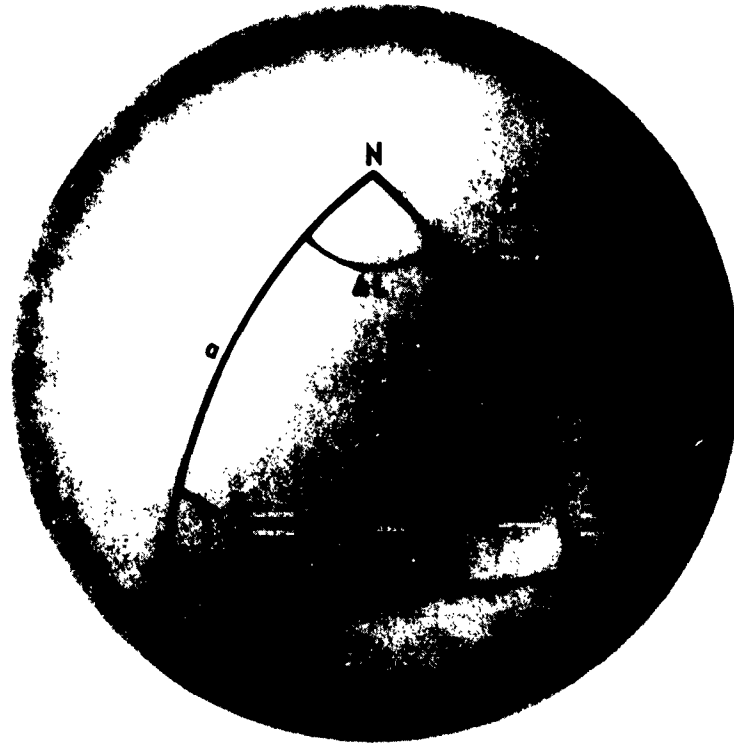

N = North Pole

Fig. 4: Spherical Triangle Used for Finding Point A.

and thus

$$\text{Ring Prob}_N = \text{Disk Prob}_N - \text{Disk Prob}_{N-1}$$

and finally

$$\text{Area Prob}_N = \frac{\text{Ring Prob}_N}{8} = \frac{\text{Disk Prob}_N - \text{Disk Prob}_{N-1}}{8}$$

We also note that, to start the process of iteration, we have

$$\text{Disk Prob}_0 = 0$$

also

$$\sigma = 0.8493 \times \text{CEP}$$

and the value of the CEP is given in the object table.

**TIME OF FINDING.** The time of arrival of the search vehicle at a given area, or the time of finding, is taken as a constant for all areas on a given ring, specifically as the time halfway around, i. e., as

$$T_{F, N} = T_{F, N-1} + \frac{\pi(R_N + R_{N-1}) + 2W}{V_s}$$

and, for the first ring

$$T_{F, 1} = T_{SCR, S} + \frac{\text{Dist (base to MPI)} - W + \pi W}{V_s} \cdot$$

Thus, by subtraction

$$T_{F, 0} = T_{SCR, S} + \frac{\text{Dist} + (\pi - 3)W}{V_s}$$

which is used for programming convenience as to starting statement.

**ENDURANCE TIME.** Before these area probabilities are calculated, a test is made to determine whether the endurance time is sufficient for traversing this circle of radius  $R_N$  by testing if

$$T_{F, 0} - T_{SCR, S} + \frac{\text{Dist} + \pi R - R}{V_s} > T_{END, S} \cdot$$

That is, can the circle be completed and can return to base be made within the search vehicle endurance time?

**TOTAL AREA SEARCHED.** The total area searched is computed from the formula

$$A_S = 2\pi R_E \left[ 1 - \cos\left(\frac{R_N + W}{R_E}\right) \right]$$

where

$A_S$  = area searched

$R_N$  = radius of  $N^{\text{th}}$  circle

$R_E$  = radius of the earth.

#### SECTION 4 - DESCRIPTION OF COMPUTER PROGRAM

The nature of the model which is mechanized has been described earlier in this report and the formulas used have been given in detail in Section 3 - Mathematics of The Model. In the interest of clarity, the flow charts in the following description deviate from the actual details of the program in a few places, not however, to an extent that should cause any confusion about the flow of the program.

The AFGC modification of the "FIB" monitor was employed. This permits the intermingling of main programs and subprograms, which may individually be written in either FORTRAN or FAP. This flexibility of language proved most advantageous in constructing the program. The main program, including tests for recognizing types of input cards, was written in FORTRAN, as was the whole of the computation block. However, several subroutines written in FAP were employed where packing and unpacking or other manipulation of bits within a word was required.

#### SIZE AND SPEED OF COMPUTER PROGRAM

The program proper, including necessary library subordinates, occupies roughly 8000 addresses in core, and the tables occupy roughly another 8000, so that in all about 16,000 of the 32,768 (32 K) addresses in the AFGC IBM 7090 installation are utilized in running this program. Of the addresses taken up by tables, approximately 6000 are used for the one table, GLOBE, which is thus a major item.

It takes roughly two minutes to compile the program from the symbolic decks. The time required to actually compute a factorial experiment will naturally vary considerably, but in preliminary testing, 32 case experiments which appeared typical were run in about 1 1/2 minutes. Printing was done off-line using an IBM 1401.

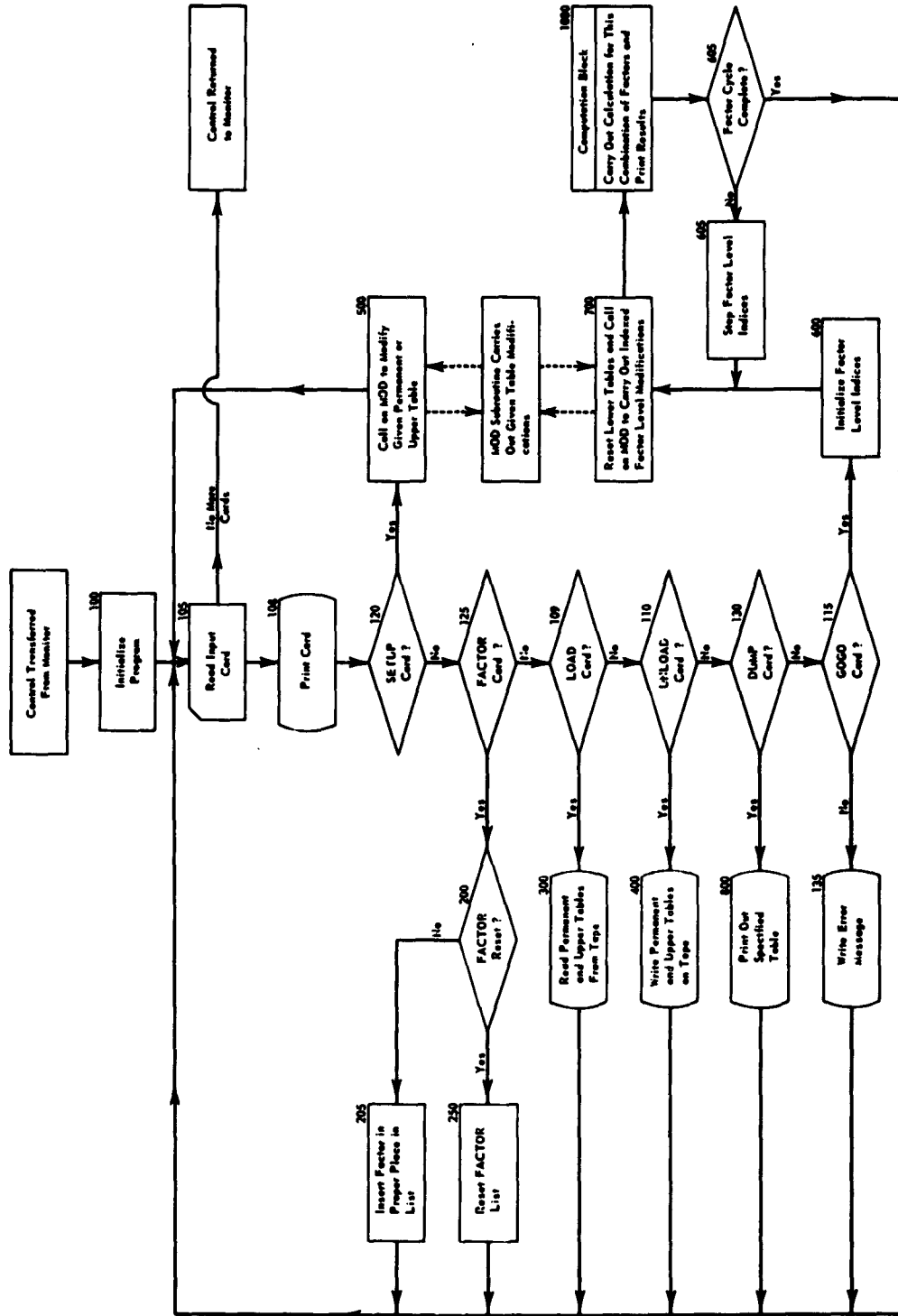

Fig. 5: Flow Chart for Overall Program.

## DUPLICATION OF CERTAIN TABLES

In order to carry out the variation of parameters called for by a factorial experiment it is necessary to vary the factors independently. In fact, it is necessary to restore each table to its original or standard values as set up before applying each modification. (Certain "permanent" tables are not subject to such variations.) It was thus necessary to duplicate those tables which can be factorially modified; one set (the upper tables) contained the SETUP or standard values for resetting purposes, the other set (the lower tables) contained the current values to be used with those in the permanent tables in calculating a given case.

In actual program, all tables except the permanent tables (GLOBE, VIAB, and PROB) are duplicated. Thus, in addition to the tables SBASE, RBASE, OBJ, SDOCT, and RDOCT, which will now be referred to as lower tables, there is also another set of tables, of identical format, which are known as upper tables. Within the program, these upper tables are called USBASE, URBASE, etc., though not so prefixed by U in input card formats for either SETUP or FACTOR cards. See Appendix II for a discussion of input card formats.

## MAIN PROGRAM

The heart of the program is block 1000, the computation block. Every other part deals with manipulations of tables and lists, setting up various combinations of conditions under which the computation block will be executed. Fig. 5 is the flow chart of the overall program; Fig. 6 is a more detailed chart of the computation block. Except where noted, the program was written in FORTRAN. The numbers of the following paragraphs correspond to the appropriate block in Fig. 5, and the function of each block is described.

100. Certain often-used constants are given names and page headings, and numbering blocks are initialized.

105. An input card is read. It is later interpreted in block 109. If no card is present when control reaches block 105, control returns to the monitor and the machine run is over.

108. Each input card is immediately printed to provide a more complete reconstruction of the computation for the output.

120, 125, 109, 110, 130, 115. A series of tests is made to determine which type card was just read in, and control is sent to the proper block, i. e., to:

300 - if a LOAD card is being read.

400 - if an UNLOAD card is being read.

600 - if a GOGO card is being read.

500 - if a SETUP card is being read.

200 - if a FACTOR card is being read.

800 - if a DUMP card is being read.

135 - if card format is not one of the above, i. e., incorrect.

200. A test is made, by a FAP subroutine (SUB1) to determine what sort of FACTOR card is present, and:

a. If word 2 (cols 7-12 incl) consists of RESET, control passes to 250.

b. If word 2 has allowable factors and levels (shown in cols 8 and 10 through 12 respectively), control passes to 205.

c. If word 2 does not meet either criteria, the card is ignored, and control passes to 105 and another card is read.

205. The information is stored in the FACTOR list in the position designated by the indices L and N, M.

250. The FACTOR list is reset. A NULL factor is stored as level No. 1 of each factor and DONE is inserted for all other levels including the 11<sup>th</sup> levels, which can contain no other data.

300. The tables are read into memory from magnetic tape. The tables must have been generated and stored on previous runs of this program by the use of SETUP cards and an UNLOAD card. (See blocks 400 and 500.)

400. The tables are written on magnetic tape for the purpose of being used on subsequent runs of this program, as described under block 300 above.

500. The SETUP cards are used to insert values into the various upper and permanent tables. A FAP subroutine (MOD)\* is used to

---

\*MOD This is a subroutine written in FAP which is employed to "modify" any table in memory. The "Modification" includes original setting up of the data in these tables. It is called up by either block 500 or block 700.

decode the necessary information and to decide which table and which portions of it are to be set up.

600. This block and block 605 are interconnected in the program. Together they pick which of the factorial cases is to be run next. At block 600, the process is started by choosing the first level for each of the five factors, and transferring control to block 700. After the first case has been computed by block 1000, control returns to 605.

605. We now wish to choose the next case. We do this by stepping up factor 5, and if the next level is not a DONE, transferring control to block 700. If this higher level is a DONE, however, this factor is restored to its first level, and the next lower factor is stepped up and again tested. This is continued until either some factor is stepped into a level not containing a DONE, with resulting transfer of control to 700, or it is determined that the entire set of factorial combinations has been run through, whereupon control passes to 105.

700. This block carries out the final readying for actual computation by ordering the modifications in the lower tables which correspond to the information in the factor and level chosen by block 605. Actually this modification is carried out by subroutine MOD.

Thus actually for each case, block 700 first restores all lower tables, then makes the modifications required by block 605 (or 600), operating through MOD, as noted.

When called by block 500, MOD is used to make the modifications in permanent tables or in upper tables as called for by SETUP cards.

When called by block 700, MOD is used to make modifications to lower tables as directed by that block, i. e., it resets all lower tables to the values in their corresponding upper tables, then modifies them as required by the particular factor table combination chosen in block 605 (or 600).

## COMPUTATION BLOCK

The detailed flow chart of the computation block is given in Fig. 6. This block is written entirely in FORTRAN. Control reaches this block from 700 after all specified factorial modifications have been made. The computer block consists of three portions. The first deals with certain preliminary calculations including the selection of the search vehicle and of the retrieval vehicle. The second deals with the generation of the

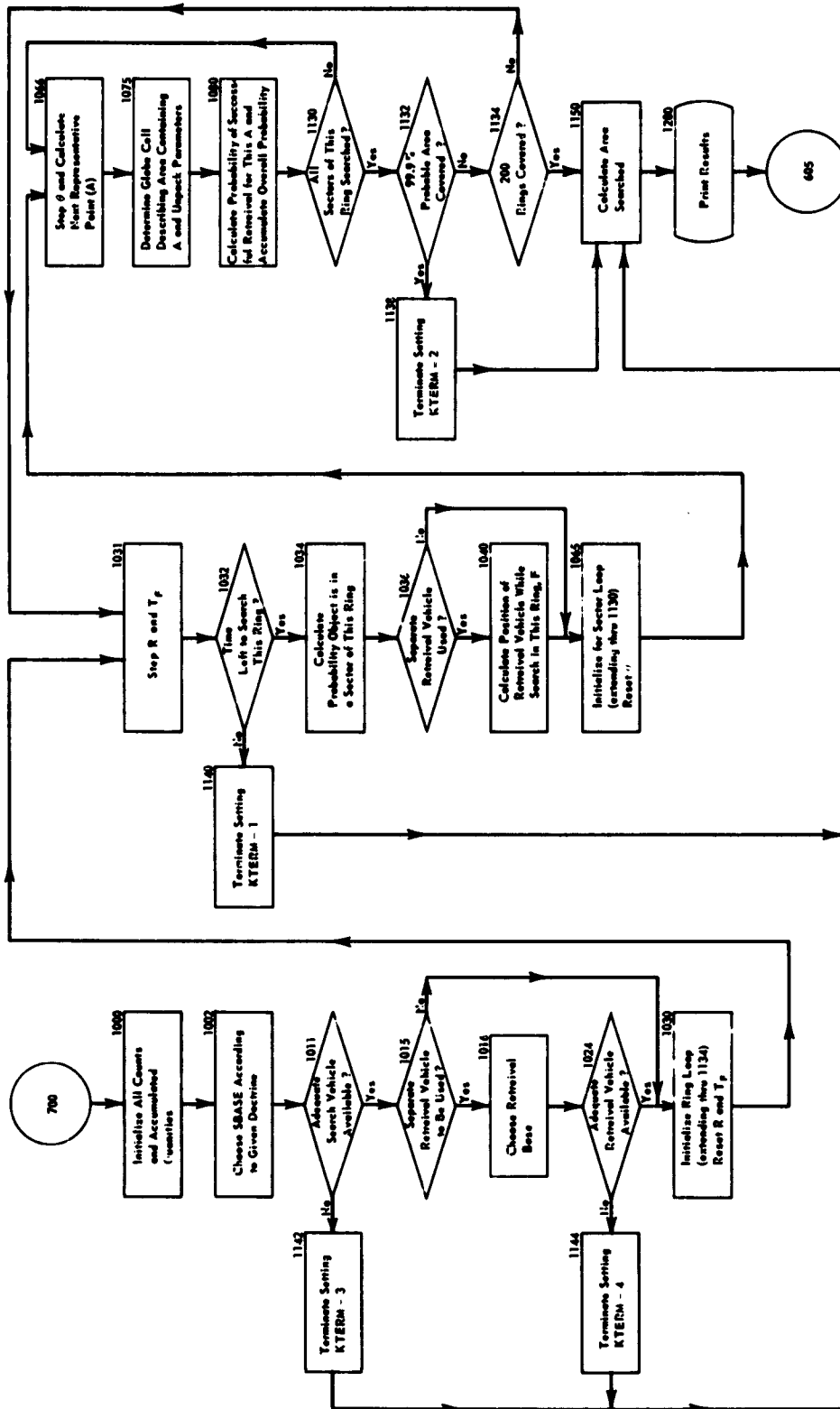

Fig. 6: Flow Chart of Computation Block.

representative points, and the calculation of the quantities associated with them. The third computes some additional values and prints the one line of output generated by the whole process.

The second portion of the computer block consists of two nested loops. The outer (N) loop is associated with the radii of the series of concentric circles about the MPI. The inner (M) loop is associated with the angular location of the series of representative points lying on the circumferences of these circles. The M loop is executed exactly eight times (eight equally spaced points are generated on each circle), and the N loop can be executed a maximum of 200 times, but is almost always left earlier due to some condition of time or area covered.

1000. Certain accumulated quantities are set to zero, and information about the probable location of the object and the method of search and recovery to be used is extracted from tables OBJ, SDOCT, and RDOCT, respectively. This consists of the colatitude and longitude of the MPI and two numbers denoting the criteria for choosing the search base and retrieval base.

1002. The best search base is chosen from the table SBASE according to the search doctrine DRITS. DRITS determines whether the chosen base is to be best in the terms of: (1) closest to the MPI, (2) can reach the MPI soonest, (3) having reached the MPI can search longest or, (4) can search the greatest area.

1011. It is determined here whether the best search vehicle has the endurance to reach the MPI and have at least some time left for searching before it is necessary to return. If not, the calculation is terminated.

1015. It is determined whether retrieval is to be accomplished by the search vehicle itself or by a separate retrieval vehicle. This is under the control of KRITR (retrieval criterion) obtained from RDOCT in block 1000.

1016. A retrieval base is chosen.

1024. It is determined whether to terminate the calculation due to the lack of an adequate retrieval vehicle (one that can make it to the MPI and back to its base). Information is determined as to the locations of the retrieval base, its distance from the MPI, and the speed, endurance time, and scramble time of the retrieval vehicle.

1030. Here the initialization for the N (ring) loop is performed.  $R_N$ , the radius of the circle, is set so that the first circle will have

radius  $W$ , the sweep width of the search vehicle, and  $T_F$  is set so that its value for the first circle will be the average time of finding the object if it is in the first ring.

1031. Here  $R$  is increased by  $2W$  so that successive circles will be spaced in such a way that the search vehicle can cover all the area between them.  $T_F$  is increased by the appropriate amount so as to represent the average time it would take to find the object if it is in the current ring.

1032. It is determined whether sufficient time remains for the search vehicle to complete the search of the current ring and return to its base within its endurance time. If not, search is terminated.

1034. The probability that the object is in one of the eight sectors of this ring is calculated. This probability,  $P_A$  or AREAP, will be used as a weight in the weighted average of individual probabilities, and is calculated at this point of the program since it is the same for each sector of this ring.

1036. If a separate vehicle is used, we next calculate its expected position at the time of finding the object if the object is found in this ring. This point ( $F$ ) is determined from  $T_F$ , the position of the MPI, and information about the location of the retrieval base and the capabilities of the retrieval vehicle obtained in block 1016. It is assumed that when the search vehicle sights the object, it will inform the retrieval vehicle of the object's location so that the retrieval vehicle's course can be altered to proceed directly to the location. This point of turning is needed later to calculate the time the retrieval vehicle reaches the object. This point is assumed to be the same for each sector of this ring. If no separate retrieval vehicle is used, this portion of the program is bypassed.

1065. Here, initialization takes place for the  $M$  (or angle) loop.  $\theta$  starts from  $0.2$  radian rather than from  $0$  so that  $A$  is never due north of the MPI. This has the effect of eliminating certain exceptional conditions from the subsequent calculation of the position of  $A$ .

1066.  $\theta$  is stepped by  $\pi/4$ , and the coordinates of  $A$  are calculated. Thus, the eight points will be equally spaced about the circle.

1075. In this block, the position of  $A$  is used to determine which cell in the GLOBE table contains the description of the area containing  $A$ , and this information is unpacked.

1080. At this point all the necessary information has been obtained

to calculate the probability of successfully retrieving the object if it is at the point A. This is done, after which it is multiplied by the weighting factor  $P_A$  to find the incremental probability  $\Delta P(N, M)$ , and accumulated to give the cumulative probability  $F$  for the points so far tested.

1130. If all eight points A have been generated, the program proceeds. Otherwise control is returned to the top of the M loop to generate another angle.

1132. At this point, it is determined whether the probability that the object is inside the area searched is greater than 0.999 on the basis of the CEP and the current value of  $R_N$ . If so, the generation of rings is terminated.

1134. If control reaches this point and less than 200 rings have been generated, control is returned to the top of the N loop to generate another radius. Otherwise, ring generation is terminated.

1138. KTERM is a flag, denoting the reason the generation of points A was terminated. This information is printed as output for the benefit of the user. For this program, it is set to 2 to denote that the maximum allowable number of areas (8 x 200) were covered.

1140. KTERM is set to 1 to denote that calculation was terminated due to reaching the end of the search vehicle's endurance time.

1142. KTERM is set to 3 to denote the lack of a suitable search vehicle, i. e., one which could reach the MPI and return within its endurance time.

1144. KTERM is set to 4 to denote the lack of a suitable retrieval vehicle, again one with sufficient endurance to reach the MPI and return to base.

1150. The total area in square miles is calculated from the final value of  $R_N$ .

1200. At this point, all output quantities have been calculated and are printed. A case has now been completed, and control passes to block 605.

## SECTION 5 - DISCUSSION OF RESULTS

As has been described, a model simulating a specific type of Global Search and Recovery problem with variable parameters was actually constructed and tested. Considerable insight was gained into the nature and magnitude of the problems which would be encountered in any such simulation program. The global requirement was the determining factor in the problem.

The concept of characterizing the surface of the globe by dividing it into regions within which the several pertinent parameters could be considered constant still seems a basically valid one. However, the practical difficulties of choosing a satisfactory size for a region (called sector in this report) and of actually coding such a global table for a realistic problem were seen to be enormous. Even the coding of the relatively small number of sectors chosen for this investigation was soon found to be far from a simple chore. Such difficulties appear inherent to the problem, and no real solution is evident. Probably specific choices of area size will be required depending on the nature of the simulation to be performed and on the available resources for ascertaining the pertinent parameters and for actually coding the global sector table to be employed. For limited areas, the problem can of course be greatly simplified, and this may be required for nonglobal problems.

The concept of assigning the remaining parameters to search or retrieval bases or to the searched-for object itself was also a simplification of actual conditions. However, it seems to be a reasonable concept, at least for preliminary studies, using a model similar to that here considered.

The model itself, with its single type of search and two fixed types of retrieval, was intended primarily as an example of the sort of models which might be employed. It is too inflexible to be entirely representative of the types of search and retrieval problems to be anticipated. In future work, a more general model, utilizing Monte-Carlo techniques, appears to be a more promising approach. Nevertheless, the model used did reveal considerable information about the type of conceptual and even geometrical problems which occur, for example, the difficulties encountered with ambiguities and special cases if the method of spherical trigonometry are used, together with ways of avoiding most of these troubles. Also, it soon became clear that any realistic model of retrieval using land vehicles, taking account of constraints such as road systems available and topographical barriers to nonroad vehicle travel, could easily become extremely complex. For limited areas, again the situation

might be quite different. Possibly on the global scale, some sort of average travelability parameters, analogous to those for probability of safe landing, etc., might be used, again in broadbrush fashion. This remains an unexplored problem.

The concepts of using tables for parameters and of the factorial variability of these parameters appear to be basically sound and useful. In view of the extremely large number of global sectors for which parameters need definition, and the small but not insignificant number of parameters required for describing other conditions, the need for a means for introducing such parameters in a convenient straightforward manner is compelling. It must be done so as to minimize the effort required and hold errors to a minimum.

As examples of minor shortcomings of the present program which proved annoying in this respect, the following is noted:

1. The width in longitude of the global sectors was chosen as 4 degrees, to give what seemed to be reasonable balance between size and number of sectors. This choice was unfortunate since most maps are graduated in multiples of 5 degrees.
2. The formats of input cards used to introduce parameters were very similar, but the few deviations from truly identical format which were made caused errors.
3. The omission of a printout of the "factor table" proved a handicap, since after a succession of modifications, its contents were not obvious.

## SECTION 6 - CONCLUSIONS

Simulation of Global Search and Recovery problems can never be easy and is possible only by greatly simplifying such factors as the geography of the earth and its effects. By making such simplifying assumptions, models of considerable promise can be constructed which are amenable to use on high speed computers. The degree to which such models will be realistic remains to be determined.

BIBLIOGRAPHY

A Study of Retrieval Concepts, Final Report, SR 49759, General Electric Corporation (Defense Systems Department), April 1961 (Secret report).

SR-49759 - Retrieval Concepts Study, Final Study, Cook Research Laboratories, 6 April 1961 (Secret report).

Study of Retrieval Concepts under ARDC Study Requirements No. 49759, Final Progress Report, Grumman Aircraft Engineering Corporation (Grumman Project No. 258), 3 April 1961 (Confidential report).

APPENDIX I  
 FACTORIAL EXPERIMENTS

DEFINITION OF FACTORIAL EXPERIMENT

The term "factorial experiment" comes from the field of Statistical Design and Analysis of Experiments. It applies to an experiment in which the effects of a number of different factors are investigated simultaneously. This is done by setting up the complete set of cases (or "treatments" in the statistician's nomenclature) comprising all combinations of all "levels" investigated of each factor. Thus we might choose, for example:

FACTOR I = Sweep Width

LEVEL 1 = 0.5 NM

LEVEL 2 = 10 NM

LEVEL 3 = 100 NM

FACTOR II = CEP

LEVEL 1 = 10 NM

LEVEL 2 = 100 NM

FACTOR III = Retrieval Doctrine

LEVEL 1 = Search vehicle also retrieves

LEVEL 2 = Separate vehicles used for retrieval

This would provide a possibility for 12 (3 x 2 x 2) cases, as follows:

<u>Case No.</u>	<u>Factor I at Level</u>	<u>Factor II at Level</u>	<u>Factor III at Level</u>
1	1	1	1
2	1	1	2
3	1	2	1
4	1	2	2
5	2	1	1
6	2	1	2
7	2	2	1
8	2	2	2
9	3	1	1
10	3	1	2
11	3	2	1
12	3	2	2

In an actual experiment it is necessary to repeat (replicate) each case and to randomize the order in which the cases are run. Neither of these requirements holds, naturally, for the simulated experiments described in this report.

#### POSSIBLE METHODS OF VARYING PARAMETERS

**ELEMENTARY METHOD.** Factorial experiments could be run "bruteforce" by specifying each case separately using SETUP cards, followed for each case by a GOGO card. The number of cards required for such an experiment may become quite considerable for sizeable experiments. In Table I-1, the number of cards so required is compared with the corresponding number required using the Factor Table method described below. By a 3 x 2 factorial design, for example, we mean one factor at each of 3 levels and another at each of 2. This is a standard notation.

TABLE I-1. COMPARISON OF METHODS OF VARYING PARAMETERS.

Factorial Design	Number of Cases	Number of Modification Cards Required	
		Using Additional SETUP Cards *	Using FACTOR Cards **
2x1	2	1	1
2x2	4	4	2
3x2	6	7	3
3x3	9	10	4
4x2	8	10	6
2x2x2	8	11	3
3x3x3	27	36	6
2x2x2x2	16	26	4
3x3x3x3	81	115	8
2x2x2x2x2	32	57	5
3x3x3x3x3	243	323	10
2x3x4x5	120	148	10
10x10x10	1,000	1,107	27
10x10x10x10x10	100,000	111,105	45

\* In addition a number of GOGO cards equal to the number of cases would be required.

\*\* In addition one FACTOR RESET and one GOGO card are required.

The formula for the number of cards required by the elementary method is

$$\text{Number of cards} = \sum_{P=1}^5 M_P$$

where  $M_P$  = number of cards to modify the  $P^{\text{th}}$  factor, and where

$M_P = (l_1 \cdot l_2 \cdots l_P) - 1$  if  $l_P \neq 1$ ,  $M_P = 0$  if  $l_P = 1$ , and  $l_P$  = number of levels in  $P^{\text{th}}$  factor.

**FACTOR TABLE METHOD.** In this method, a much smaller number of cards need be punched, in fact

$$\text{number of cards} = \sum_{P=1}^5 (l_P - 1)$$

where  $l_P$  = number of levels of the  $P^{\text{th}}$  factor (only one card for each level, except the first, of each factor). Here we have assumed throughout for comparison, that the first level of each factor will be the unchanged original value, which is the normal situation.

It should be noted that the number of cases which will be computed, not the number of cards required, will undoubtedly be the limiting factor in running factorial experiments by this method. Even for a computer such as the IBM 7090, an experiment with 100,000 cases will require more computing time than is likely to be warranted.

In addition to the tables described elsewhere, the program also provides a region in memory, FACT (I, J, K), which is essentially another three-dimensional table, and which may be called the factor table. Information as to what modifications are to be made, factorially, in the main tables during an experiment is stored in this region. The indices L and M refer, respectively, to the Factor and to the level of the modification for which data is stored. Essentially this data is identical with that contained in a SETUP card, except that it cannot refer to GLOBE, PROB, or VIAB. It is used preceding each calculation to modify the proper lower tables after they have been restored to the standard values as stored in the upper tables by the SETUP cards.

The third index (K) is required only because all the data which can be given on one card cannot go into one word - in fact, ten words are required. For simplicity, this index may be neglected and the factor table as being a two-dimensional table set up as follows:

LEVEL	FACTOR				
	I	II	III	IV	V
1	F1, 1	F2, 1	F3, 1	F4, 1	F5, 1
2	F1, 2	F2, 2	F3, 2	F4, 2	F5, 2
3	F1, 3	F2, 3	F3, 3	F4, 3	F5, 3
4	-----	-----	-----	-----	-----
.	-----	-----	-----	-----	-----
.	-----	-----	-----	-----	-----
10	F1, 10	F2, 10	F3, 10	F4, 10	F5, 10
11	DONE	DONE	DONE	DONE	DONE

The cue to the program that all specified factorial modifications have been made for a given factor is the presence of the word DONE in the next higher level. We thus provide an 11<sup>th</sup> level in the factor table which always contain DONE's and is not addressable by the user of the program. A given level which consists of no change is indicated by the presence of the word NULL in that level. Each level of each factor (10 x 5 or 50) can be set by a separate card.

Factor Reset Card. For convenience, we have provided a FACTOR RESET card, which by itself, will set up the following table:

LEVEL	FACTOR				
	I	II	III	IV	V
1	NULL	NULL	NULL	NULL	NULL
2	DONE	DONE	DONE	DONE	DONE
3	DONE	DONE	DONE	DONE	DONE
.	-----	-----	-----	-----	-----
.	-----	-----	-----	-----	-----
.	-----	-----	-----	-----	-----
10	DONE	DONE	DONE	DONE	DONE
11	DONE	DONE	DONE	DONE	DONE

This is the desired table for a simple single-case, no-modification, factorial experiment, and if no further FACTOR cards precede the GOGO card, that one case is what will be run as that entire experiment.

General Experiment. The FACTOR RESET card is also useful in general, since this one card sets in the required DONE's and NULL's, and only those modifications desired need be specified by other factor cards.

For example, suppose only the following factorial variations are desired expressed symbolically:

FACTOR 1, 2     M1, 2  
 FACTOR 1, 3     M1, 3  
 FACTOR 3, 1     M3, 1

Then the table configuration resulting from use of FACTOR RESET followed by these three cards would be, symbolically:

LEVEL	FACTOR				
	I	II	III	IV	V
1	NULL	NULL	M3, 1	NULL	NULL
2	M1, 2	DONE	DONE	DONE	DONE
3	M2, 3	DONE	DONE	DONE	DONE
4	DONE	DONE	DONE	DONE	DONE
.	-----	-----	-----	-----	-----
.	-----	-----	-----	-----	-----
.	-----	-----	-----	-----	-----
10	DONE	DONE	DONE	DONE	DONE
11	DONE	DONE	DONE	DONE	DONE

Note that in this example we have chosen not to compute a case with Factor III at its setup values at all. This can be done although, in general, it is undesirable.

The 11<sup>th</sup> level DONE's are necessary to safeguard the program, and higher levels have no meaning. Any attempt to store factors above five, or levels above 10 will be ignored, since tests are provided to prevent such assignments.

What is chosen as a given factor is completely flexible except for parameters in the GLOBE or its auxiliary tables. Different levels of a factor may even be different parameters. However, since this disturbs the experiment from its truly factorial character, such usage is not generally recommended, although it may be desirable in special cases.

In actual operation when a GOGO card is read before a case is run, the program restores all lower tables to the upper table (standard) values. It then makes the changes called for by that case, runs it, the case restores the values, then modifies lower tables again until all cases called for have been run. The experiment is then terminated, and the program reads another card, which may start the specification of the parameters for a new experiment by SETUP and/or FACTOR cards or, if no further card is present, terminate the machine run.

## APPENDIX II INPUT CARD FORMATS AND AUXILIARY TABLE VALUES

### INPUT CARD FORMATS

The formats of the various input cards are shown in Fig. II-1. Where  $I_1$  and  $I_2$  and  $J_1$  and  $J_2$  are shown as in the GLOBE table, all members of that table for values of  $I$  from  $I_1$  to  $I_2$  and  $J_1$  to  $J_2$  inclusive are to be affected. For SBASE and RBASE, only  $I_1$  and  $I_2$  are used with a similar meaning. Where flags are shown, the inclusion of any punch in this column causes entry of the corresponding identified data which otherwise is ignored. For FACTOR cards, F and LL correspond to factor and level respectively.

### GLOBE WORD FORMAT

As a matter of interest, the format of a GLOBE word is shown in Fig. II-2.

### OUTPUT FORMAT

As each card is read in, it is printed out in identical format. This will appear in the printed output. In addition, any tables for which DUMP cards appear will be printed out for later checking. The formats of these tables will not be described here but can be found in the original program.

The essential output, i. e., the computed results from each experiment, is printed out after the printout of each GOGO card. An illustrative printout for a  $2 \times 4 \times 2 \times 2 \times 1$ , i. e., 32-case experiment, is shown in Fig. II-3. This shows the way the problem was set up, the factor table, and the computed results as printed out.

### SUGGESTED VALUES FOR AUXILIARY TABLES

Suggested values for the PROB auxiliary tables are shown in Table II-1, and the values for VIAB are shown in Table II-2. The subroutine FAPCON is required as it is used by MOD in decoding the values in these tables.



5	1	2	3	4	5	6	7	8	9	10	11	12	13	14	15	16	17	18	19	20	21	22	23	24	25	26	27	28	29	30	31	32	33	34	35
K <sub>1</sub>					K <sub>2</sub>					K <sub>3</sub>					K <sub>4</sub>					K <sub>5</sub>					K <sub>6</sub>					K <sub>7</sub>					
TOPOG					CNTRY					PROBSL					POL					VIAB <sub>1</sub>					VIAB <sub>2</sub>					Not Used					
1	2	3	4	5	6	7	8	9	10	11	12	13	14	15	16	17	18	19	20	21	22	23	24	25	26	27	28	29	30	31	32	33	34	35	36

Fig. II-2: Globe Word Format.

TABLE II-1. PROBABILITY (PROB) TABLE (SUGGESTED VALUES).

K	PROB	xyz	K	FROB	xyz
1	.00	000	17	.45	450
2	.01	010	18	.50	500
3	.02	020	19	.55	550
4	.03	030	20	.60	600
5	.04	040	21	.65	650
6	.05	050	22	.70	700
7	.07	070	23	.75	750
8	.08	080	24	.80	800
9	.10	100	25	.85	850
10	.12	120	26	.90	900
11	.15	150	27	.95	950
12	.20	200	28	.96	960
13	.25	250	29	.97	970
14	.30	300	30	.98	980
15	.35	350	31	.99	990
16	.40	400	32	1.0	101

TABLE II-2. VIABILITY (VIAB) TABLE CODING (SUGGESTED VALUES).

K	xyz	Time (Hr)	K	xyz	Time (Hr)
1	000	0	41	182	18
2	010	.01	42	202	20
3	020	.02	43	222	22
4	030	.03	44	242	24
5	040	.04	45	262	26
6	050	.05	46	282	28
7	060	.06	47	302	30
8	070	.07	48	352	35
9	080	.08	49	402	40
10	090	.09	50	502	50
11	100	.10	51	752	75
12	150	.15	52	103	100
13	200	.20	53	153	150
14	250	.25	54	203	200
15	300	.30	55	253	250
16	400	.40	56	303	300
17	500	.50	57	403	400
18	600	.60	58	503	500
19	700	.70	59	753	750
20	750	.75	60	104	1000
21	800	.80	61	154	1,500
22	900	.90	62	204	2,000
23	101	1.0	63	304	3,000
24	151	1.5	64	404	4,000
25	201	2	65	504	5,000
26	301	3	66	754	7,500
27	401	4	67	105	10,000
28	501	5	68	255	25,000
29	601	6	69	505	50,000
30	701	7	70	755	75,000
31	801	8	71	106	100,000
32	901	9	72	256	250,000
33	102	10	73	506	500,000
34	112	11	74	756	750,000
35	122	12	75	107	106
36	132	13	76	257	2.5x10 <sup>6</sup>
37	142	14	77	507	5.0x10 <sup>6</sup>
38	152	15	78	757	7.5x10 <sup>6</sup>
39	162	16	79	108	10 <sup>7</sup>
40	172	17	80	999	largest

Table II-2 Continued.

K	xyz	Time (Hr)	K	xyz	Time (Hr)
81	170	0.17	96	144	1,440
82	330	.33	97	224	2,160
83	840	.84	98	444	4,380
84	362	36	99	764	7,570
85	482	48	100	884	8,760
86	722	72	101	135	13,140
87	962	96	102	185	17,520
88	123	120	103	205	20,280
89	143	144	104	355	35,040
90	173	168	105	445	43,800
91	243	240	106	885	87,600
92	343	336	107	886	876,000
93	503	504	108 through 128 - Spare, set 000 at present.		
94	723	720			
95	104	1,030			



SETUP	RBASE 40 40	11	34	S 71	M	SANTI		
SETUP	RBASE 41 41	11	34	S 50	M	BUENO		
SETUP	RBASE 42 42	11	22	S 43	M	RIO D		
SETUP	RBASE 43 43	11	53	S 72	M	PUNTA		
SETUP	RBASE 44 44	11	43	S 173	E	CHRIS		
SETUP	RBASE 45 45	11	20	S 50	E	MAARI		
SETUP	RBASE 46 46	11	17	S 149	M	TAMIT		
SETUP	RBASE 47 47	11	40	N 122	M	SEATT		
SETUP	RBASE 48 48	11	36	N 123	M	SAM F		
SETUP	RBASE 49 49	11	21	N 115	E	HONG		
SETUP	RBASE 50 50	11	18	N 72	E	BONDA		
SETUP	SBASE 1 1	11	10	S 97	E	COC OS		
SETUP	SBASE 2 2	11	31	S 114	E	PERTH		
SETUP	SBASE 3 3	11	15	N 123	E	NAMIL		
SETUP	SBASE 4 4	11	12	S 133	E	DARMI		
SETUP	SBASE 5 5	11	30	S 130	E	MOONE		
SETUP	SBASE 6 6	11	37	S 145	E	MIABQ		
SETUP	SBASE 7 7	11	37	N 141	E	TONYO		
SETUP	SBASE 8 8	11	14	N 145	E	QAMN		
SETUP	SBASE 9 9	11	12	N 140	E	EININ		
SETUP	SBASE 10 10	11	19	N 147	E	MAKE		
SETUP	SBASE 11 11	11	9	N 140	E	KHAJA		
SETUP	SBASE 12 12	11	28	N 17A	M	RIDMA		
SETUP	SBASE 13 13	11	2	S 171	M	CANTO		
SETUP	SBASE 14 14	11	20	N 155	M	HONOL		
SETUP	SBASE 15 15	11	25	N 12C	E	FORMC		
SETUP	SBASE 16 16	11	41	S 109	M	EASTE		
SETUP	SBASE 17 17	11	3025M	0436M		EGLIN		
SETUP	SBASE 18 18	11	29	M 80	M	AMB		
SETUP	SBASE 19 19	11	41	N 69	M	N Y		
SETUP	SBASE 20 20	11	32	N 70	M	BERNU		
SETUP	SBASE 21 21	11	49	N 50	M	GANDE		
SETUP	SBASE 22 22	11	64	N 21	M	REFLA		
SETUP	SBASE 23 23	11	39	N 26	M	AZORE		
SETUP	SBASE 24 24	11	15	M 18	M	DARAR		
SETUP	SBASE 25 25	11	7	S 14	M	ASCEN		
SETUP	SBASE 26 26	11	52	M 0	M	LONDO		
SETUP	SBASE 27 27	11	25	S 20	E	JOHAN		
SETUP	SBASE 28 28	11	49	S 40	E	KEGOU		
SETUP	SBASE 29 29	11	53	N 175	E	SHEBY		
SETUP	SBASE 30 30	11	45	N 147	M	FAIR		
SETUP	SBASE 31 31	11	3130M	150	M	ARANG		
SETUP	SBASE 32 32	11	50	N 134	M	JAMEA		
SETUP	SBASE 33 33	11	77	N 60	M	TULE		
SETUP	SBASE 34 34	11	53	N 0	M	SHANN		
SETUP	SBASE 35 35	11	61	N 10	E	OSLO		
SETUP	SBASE 36 36	11	40	N 20	E	MARRI		
SETUP	SBASE 37 37	11	24	N 50	E	SHANN		
SETUP	SBASE 38 38	11	2	N 92	M	GALAP		
SETUP	SBASE 39 39	11	4	S 32	M	NOCLI		
SETUP	SBASE 40 40	11	34	S 71	M	SANTI		
SETUP	SBASE 41 41	11	34	S 50	M	BUENO		
SETUP	SBASE 42 42	11	22	S 43	M	RIO D		
SETUP	SBASE 43 43	11	53	S 72	M	PUNTA		
SETUP	SBASE 44 44	11	43	S 173	E	CHRIS		
SETUP	SBASE 45 45	11	20	S 50	E	MAARI		
SETUP	SBASE 46 46	11	17	S 149	M	TAMIT		
SETUP	SBASE 47 47	11	40	N 122	M	SEATT		
SETUP	SBASE 48 48	11	36	N 123	M	SAM F		
SETUP	SBASE 49 49	11	21	N 115	E	HONG		
SETUP	SBASE 50 50	11	10	N 72	E	BONDA		
SETUP	SBASE 1 50	11	1111	C 150C		200209505000		
SETUP	RBASE 1 50	11	11	01000		30500		
SETUP	001	11	25	M 00	M 1000			
SETUP	SDOCT	4						
SETUP	SDOCT	1						
DUMP	PROG				NEW			
1	0.00000	0.01000	0.02000	0.03000	0.04000	0.05000	0.07000	0.00000
9	0.10000	0.12000	0.15000	0.20000	0.25000	0.30000	0.35000	0.40000
17	0.45000	0.50000	0.55000	0.60000	0.65000	0.70000	0.75000	0.80000
25	0.85000	0.90000	0.95000	0.96000	0.97000	0.98000	0.99000	1.00000
DUMP	VIA8							
1	0.00000000	1.00000E-02	0.20000E-01	0.30000E-01	0.40000E-01	0.50000E-01	0.60000E-01	0.70000E-01
9	0.00000E-01	0.90000E-01	1.00000E-01	0.15000E-00	0.20000E-00	0.25000E-00	0.30000E-00	0.40000E-00
17	0.50000E-00	0.60000E-00	0.70000E-00	0.75000E-00	0.80000E-00	0.90000E-00	1.00000E-00	0.15000E-01
25	0.20000E-01	0.30000E-01	0.40000E-01	0.50000E-01	0.60000E-01	0.70000E-01	0.80000E-01	0.90000E-01
33	0.10000E-02	0.11000E-02	0.12000E-02	0.13000E-02	0.14000E-02	0.15000E-02	0.16000E-02	0.17000E-02
41	0.10000E-02	0.20000E-02	0.22000E-02	0.24000E-02	0.26000E-02	0.28000E-02	0.30000E-02	0.35000E-02
49	0.40000E-02	0.50000E-02	0.75000E-02	0.10000E-01	0.15000E-01	0.20000E-01	0.25000E-01	0.30000E-01
57	0.40000E-03	0.50000E-03	0.75000E-03	1.00000E-03	0.15000E-02	0.20000E-02	0.30000E-02	0.40000E-02
65	0.50000E-04	0.75000E-04	1.00000E-04	0.25000E-03	0.50000E-03	0.75000E-03	1.00000E-03	0.25000E-02
73	0.50000E-04	0.75000E-04	0.10000E-03	0.25000E-02	0.50000E-02	0.75000E-02	0.10000E-01	0.25000E-01
81	0.17000E-00	0.33000E-00	0.60000E-00	0.50000E-01	0.40000E-01	0.30000E-01	0.20000E-01	0.15000E-01
89	0.14000E-03	0.17000E-03	0.24000E-03	0.30000E-03	0.40000E-03	0.50000E-03	0.60000E-03	0.70000E-03
97	0.22000E-04	0.34000E-04	0.74000E-04	0.60000E-04	0.15000E-03	0.10000E-02	0.20000E-02	0.35000E-02
105	0.44000E-05	0.60000E-05	0.60000E-04	0.60000E-04	0.60000E-04	0.60000E-04	0.60000E-04	0.60000E-04
113	0.60000E-05	0.60000E-05	0.60000E-05	0.60000E-05	0.60000E-05	0.60000E-05	0.60000E-05	0.60000E-05
121	0.60000E-05	0.60000E-05	0.60000E-05	0.60000E-05	0.60000E-05	0.60000E-05	0.60000E-05	0.60000E-05
DUMP	SBASE							
1	1 500.	10.05	97.0E	20.	24.	0.95	50.00	
2	1 500.	31.05	116.0E	20.	24.	0.95	50.00	
3	1 500.	15.00	123.0E	20.	24.	0.95	50.00	
4	1 500.	12.05	133.0E	20.	24.	0.95	50.00	
5	1 500.	26.03	124.0E	20.	24.	0.95	50.00	
6	1 500.	37.05	145.0E	20.	24.	0.95	50.00	
7	1 500.	37.00	141.0E	20.	24.	0.95	50.00	

Fig. II-3. (Continued)

APGC-TDR-62-44

8	1	500.	14.0M	145.0E	20.	24.	0.95	50.00
9	1	500.	12.0M	140.0E	20.	24.	0.95	50.00
10	1	500.	19.0M	147.0E	20.	24.	0.95	50.00
11	1	500.	9.0M	148.0E	20.	24.	0.95	50.00
12	1	500.	28.0M	174.0M	20.	24.	0.95	50.00
13	1	500.	2.05	171.0M	20.	24.	0.95	50.00
14	1	500.	20.0M	155.0M	20.	24.	0.95	50.00
15	1	500.	25.0M	120.0E	20.	24.	0.95	50.00
16	1	500.	41.05	109.0M	20.	24.	0.95	50.00
17	1	500.	30.4M	86.6M	20.	24.	0.95	50.00
18	1	500.	29.0M	80.0M	20.	24.	0.95	50.00
19	1	500.	41.0M	69.0M	20.	24.	0.95	50.00
20	1	500.	32.0M	70.0M	20.	24.	0.95	50.00
21	1	500.	49.0M	58.0M	20.	24.	0.95	50.00
22	1	500.	64.0M	21.0M	20.	24.	0.95	50.00
23	1	500.	39.0M	26.0M	20.	24.	0.95	50.00
24	1	500.	15.0M	18.0M	20.	24.	0.95	50.00
25	1	500.	7.05	14.0M	20.	24.	0.95	50.00
26	1	500.	52.0M	0.0M	20.	24.	0.95	50.00
27	1	500.	25.05	28.0E	20.	24.	0.95	50.00
28	1	500.	49.05	68.0E	20.	24.	0.95	50.00
29	1	500.	53.0M	175.0E	20.	24.	0.95	50.00
30	1	500.	45.0M	147.0M	20.	24.	0.95	50.00
31	1	500.	31.5M	150.0M	20.	24.	0.95	50.00
32	1	500.	58.0M	134.0M	20.	24.	0.95	50.00
33	1	500.	77.0M	68.0M	20.	24.	0.95	50.00
34	1	500.	53.0M	8.0M	20.	24.	0.95	50.00
35	1	500.	41.0M	10.0E	20.	24.	0.95	50.00
36	1	500.	40.0M	20.0E	20.	24.	0.95	50.00
37	1	500.	24.0M	50.0E	20.	24.	0.95	50.00
38	1	500.	2.0M	92.0M	20.	24.	0.95	50.00
39	1	500.	4.05	32.0M	20.	24.	0.95	50.00
40	1	500.	34.05	71.0M	20.	24.	0.95	50.00
41	1	500.	34.05	58.0M	20.	24.	0.95	50.00
42	1	500.	22.05	43.0M	20.	24.	0.95	50.00
43	1	500.	53.05	72.0M	20.	24.	0.95	50.00
44	1	500.	43.05	173.0E	20.	24.	0.95	50.00
45	1	500.	20.05	58.0E	20.	24.	0.95	50.00
46	1	500.	17.05	149.0M	20.	24.	0.95	50.00
47	1	500.	48.0M	122.0M	20.	24.	0.95	50.00
48	1	500.	36.0M	123.0M	20.	24.	0.95	50.00
49	1	500.	21.0M	115.0E	20.	24.	0.95	50.00
50	1	500.	18.0M	72.0E	20.	24.	0.95	50.00
DUMP								
1	1	30.	18.05	97.0E	30.	30C.		
2	1	30.	31.05	114.0E	30.	30C.		
3	1	30.	15.0M	123.0E	30.	30C.		
4	1	30.	12.05	133.0E	30.	30C.		
5	1	30.	30.05	138.0E	30.	30C.		
6	1	30.	37.05	145.0E	30.	30C.		
7	1	30.	37.0M	141.0E	30.	30C.		
8	1	30.	14.0M	145.0E	30.	30C.		
9	1	30.	12.0M	140.0E	30.	30C.		
10	1	30.	19.0M	147.0E	30.	30C.		
11	1	30.	9.0M	148.0E	30.	30C.		
12	1	30.	28.0M	174.0M	30.	30C.		
13	1	30.	2.05	171.0M	30.	30C.		
14	1	30.	20.0M	155.0M	30.	30C.		
15	1	30.	25.0M	120.0E	30.	30C.		
16	1	30.	41.05	109.0M	30.	30C.		
17	1	30.	30.4M	86.6M	30.	30C.		
18	1	30.	29.0M	80.0M	30.	30C.		
19	1	30.	41.0M	69.0M	30.	30C.		
20	1	30.	32.0M	70.0M	30.	30C.		
21	1	30.	49.0M	58.0M	30.	30C.		
22	1	30.	64.0M	21.0M	30.	30C.		
23	1	30.	39.0M	26.0M	30.	30C.		
24	1	30.	15.0M	18.0M	30.	30C.		
25	1	30.	7.05	14.0M	30.	30C.		
26	1	30.	52.0M	0.0M	30.	30C.		
27	1	30.	25.05	28.0E	30.	30C.		
28	1	30.	49.05	68.0E	30.	30C.		
29	1	30.	53.0M	175.0E	30.	30C.		
30	1	30.	45.0M	147.0M	30.	30C.		
31	1	30.	31.5M	150.0M	30.	30C.		
32	1	30.	58.0M	134.0M	30.	30C.		
33	1	30.	77.0M	68.0M	30.	30C.		
34	1	30.	53.0M	8.0M	30.	30C.		
35	1	30.	41.0M	10.0E	30.	30C.		
36	1	30.	40.0M	20.0E	30.	30C.		
37	1	30.	24.0M	50.0E	30.	30C.		
38	1	30.	2.0M	92.0M	30.	30C.		
39	1	30.	4.05	32.0M	30.	30C.		
40	1	30.	34.05	71.0M	30.	30C.		
41	1	30.	34.05	58.0M	30.	30C.		
42	1	30.	22.05	43.0M	30.	30C.		
43	1	30.	53.05	72.0M	30.	30C.		
44	1	30.	43.05	173.0E	30.	30C.		
45	1	30.	20.05	58.0E	30.	30C.		
46	1	30.	17.05	149.0M	30.	30C.		
47	1	30.	48.0M	122.0M	30.	30C.		
48	1	30.	36.0M	123.0M	30.	30C.		
49	1	30.	21.0M	115.0E	30.	30C.		
50	1	30.	18.0M	72.0E	30.	30C.		
DUMP								
			25.00M	90.00M		100.00		

APGC-TDR-62-44

FACTOR		RESET				10L				CP10								
FACTOR		1, 2 OBJ		11		S 120		W		POSIT								
FACTOR		2, 3 OBJ		11		M 180		W		POSIT								
FACTOR		2, 4 OBJ		11		M 135		E		POSIT								
FACTOR		3, 2 SBASE		1, 50		I				200 W 2								
FACTOR		4, 2 SBASE		1, 50		I				SEND								
GGGO																		
FACTOR	I	II	III	IV	V	PROB.	TERM.	ARLA	SB	RB	AREAS	BY	TOPOG	I	-	B	UMR	
1	1	1	1	1	1	0.646	2	502088.	17	0	32	0	0	0	0	0	0	0
2	1	1	1	1	1	0.772	2	31614.	17	0	8	0	0	0	0	0	0	0
1	2	1	1	1	1	0.000	2	502088.	43	0	32	0	0	0	0	0	0	0
2	2	1	1	1	1	0.000	2	31614.	43	0	8	0	0	0	0	0	0	0
1	3	1	1	1	1	0.727	2	502088.	10	0	32	0	0	0	0	0	0	0
2	3	1	1	1	1	0.781	2	31614.	10	0	8	0	0	0	0	0	0	0
1	4	1	1	1	1	0.001	2	502088.	7	0	32	0	0	0	0	0	0	25
2	4	1	1	1	1	0.000	2	31614.	7	0	8	0	0	0	0	0	0	0
1	1	2	1	1	1	0.181	1	42270.	17	0	232	0	0	0	0	0	0	0
2	1	2	1	1	1	0.766	2	3217.	17	0	64	0	0	0	0	0	0	0
1	2	2	1	1	1	0.000	1	32978.	43	0	208	0	0	0	0	0	0	0
2	2	2	1	1	1	0.000	2	3217.	43	0	64	0	0	0	0	0	0	0
1	3	2	1	1	1	0.251	1	36405.	10	0	224	0	0	0	0	0	0	0
2	3	2	1	1	1	0.778	2	3217.	10	0	64	0	0	0	0	0	0	0
1	4	2	1	1	1	0.000	1	42270.	7	0	232	0	0	0	0	0	0	232
2	4	2	1	1	1	0.000	2	3217.	7	0	64	0	0	0	0	0	0	64
1	1	1	2	1	1	0.686	1	282564.	17	0	24	0	0	0	0	0	0	0
2	1	1	2	1	1	0.772	2	31614.	17	0	8	0	0	0	0	0	0	0
1	2	1	2	1	1	0.000	1	31614.	43	0	8	0	0	0	0	0	0	0
2	2	1	2	1	1	0.000	2	31614.	43	0	8	0	0	0	0	0	0	0
1	3	1	2	1	1	0.693	1	125629.	10	0	16	0	0	0	0	0	0	0
2	3	1	2	1	1	0.781	2	31614.	10	0	8	0	0	0	0	0	0	0
1	4	1	2	1	1	0.001	1	282564.	7	0	24	0	0	0	0	0	0	21
2	4	1	2	1	1	0.000	2	31614.	7	0	8	0	0	0	0	0	0	8
1	1	2	2	1	1	0.150	1	125688.	17	0	128	0	0	0	0	0	0	0
2	1	2	2	1	1	0.766	2	3217.	17	0	64	0	0	0	0	0	0	0
1	2	2	2	1	1	0.000	1	2464.	43	0	56	0	0	0	0	0	0	0
2	2	2	2	1	1	0.000	1	2464.	43	0	56	0	0	0	0	0	0	0
1	3	2	2	1	1	0.114	1	8495.	10	0	104	0	0	0	0	0	0	0
2	3	2	2	1	1	0.778	2	3217.	10	0	64	0	0	0	0	0	0	0
1	4	2	2	1	1	0.000	1	11510.	7	0	120	0	0	0	0	0	0	120
2	4	2	2	1	1	0.000	2	3217.	7	0	64	0	0	0	0	0	0	64

Fig. II-3. (Continued)

INITIAL DISTRIBUTION

3 AFSC (SCLDA)  
1 AFFTC (DCS/P&O)  
1 ASD (621A SPO)  
2 ASD (ASRPCF)  
2 SSD  
2 FTD  
1 NASA  
5 MATS (Air Reserve Service)  
2 PMR (Air Force Office)  
1 6594 Test Wing (TWRDD)  
15 ASTIA (TIPCR)  
APGC  
1 PGW  
6 PGWT  
1 PGWR  
2 PGVM  
2 PGAPI  
1 PGN  
5 PGGT  
3 FGEH

<p>Air Proving Ground Center, Eglin Air Force Base, Florida Rpt. No. AFCC-TDR-62-44, GLOBAL SEARCH AND RECOVERY, A Feasibility Study of Computer Simulation. Final report, November 1962, 47p. includes tables. Unclassified Report</p> <p>The subject of computer simulation was chosen for this feasibility study as this aspect does not appear to have been well covered during previous studies of the Global Search and Recovery problem. A mathematical model was constructed of a simulated search and recovery mission, and a computer program was constructed which embodied this model. The objective of this computer program was the determination of the probability of successfully retrieving a downed object when given information as to the probable location, the nature and deployment of search and recovery facilities, and a geographic and political description of the earth. Considerable attention was given to developing a convenient means of entering and varying the parameters of the model in a systematic manner. The results of this study indicate that it would be feasible to construct a computer model of at least certain aspects of the search and recovery problem which would be suitable for studies of the effects of several parameters. However, the model described is believed to be too limited and inflexible in form (though not in parameter values) to permit generalization to a larger variety of search and recovery problems. Future work along this line should probably employ a Monte Carlo type approach.</p>	<p style="text-align: center;">UNCLASSIFIED</p> <p>1. Recovery 2. Computers 3. Global Search I. AFSC Project No. 7993 II. Fanning, Russell III. In ASTIA collection.</p>	<p>Air Proving Ground Center, Eglin Air Force Base, Florida Rpt. No. AFCC-TDR-62-44, GLOBAL SEARCH AND RECOVERY, A Feasibility Study of Computer Simulation. Final report, November 1962, 47p. includes tables. Unclassified Report</p> <p>The subject of computer simulation was chosen for this feasibility study as this aspect does not appear to have been well covered during previous studies of the Global Search and Recovery problem. A mathematical model was constructed of a simulated search and recovery mission, and a computer program was constructed which embodied this model. The objective of this computer program was the determination of the probability of successfully retrieving a downed object when given information as to the probable location, the nature and deployment of search and recovery facilities, and a geographic and political description of the earth. Considerable attention was given to developing a convenient means of entering and varying the parameters of the model in a systematic manner. The results of this study indicate that it would be feasible to construct a computer model of at least certain aspects of the search and recovery problem which would be suitable for studies of the effects of several parameters. However, the model described is believed to be too limited and inflexible in form (though not in parameter values) to permit generalization to a larger variety of search and recovery problems. Future work along this line should probably employ a Monte Carlo type approach.</p>	<p style="text-align: center;">UNCLASSIFIED</p> <p>1. Recovery 2. Computers 3. Global Search I. AFSC Project No. 7993 II. Fanning, Russell III. In ASTIA collection.</p>
<p>Air Proving Ground Center, Eglin Air Force Base, Florida Rpt. No. AFCC-TDR-62-44, GLOBAL SEARCH AND RECOVERY, A Feasibility Study of Computer Simulation. Final report, November 1962, 47p. includes tables. Unclassified Report</p> <p>The subject of computer simulation was chosen for this feasibility study as this aspect does not appear to have been well covered during previous studies of the Global Search and Recovery problem. A mathematical model was constructed of a simulated search and recovery mission, and a computer program was constructed which embodied this model. The objective of this computer program was the determination of the probability of successfully retrieving a downed object when given information as to the probable location, the nature and deployment of search and recovery facilities, and a geographic and political description of the earth. Considerable attention was given to developing a convenient means of entering and varying the parameters of the model in a systematic manner. The results of this study indicate that it would be feasible to construct a computer model of at least certain aspects of the search and recovery problem which would be suitable for studies of the effects of several parameters. However, the model described is believed to be too limited and inflexible in form (though not in parameter values) to permit generalization to a larger variety of search and recovery problems. Future work along this line should probably employ a Monte Carlo type approach.</p>	<p style="text-align: center;">UNCLASSIFIED</p> <p>1. Recovery 2. Computers 3. Global Search I. AFSC Project No. 7993 II. Fanning, Russell III. In ASTIA collection.</p>	<p>Air Proving Ground Center, Eglin Air Force Base, Florida Rpt. No. AFCC-TDR-62-44, GLOBAL SEARCH AND RECOVERY, A Feasibility Study of Computer Simulation. Final report, November 1962, 47p. includes tables. Unclassified Report</p> <p>The subject of computer simulation was chosen for this feasibility study as this aspect does not appear to have been well covered during previous studies of the Global Search and Recovery problem. A mathematical model was constructed of a simulated search and recovery mission, and a computer program was constructed which embodied this model. The objective of this computer program was the determination of the probability of successfully retrieving a downed object when given information as to the probable location, the nature and deployment of search and recovery facilities, and a geographic and political description of the earth. Considerable attention was given to developing a convenient means of entering and varying the parameters of the model in a systematic manner. The results of this study indicate that it would be feasible to construct a computer model of at least certain aspects of the search and recovery problem which would be suitable for studies of the effects of several parameters. However, the model described is believed to be too limited and inflexible in form (though not in parameter values) to permit generalization to a larger variety of search and recovery problems. Future work along this line should probably employ a Monte Carlo type approach.</p>	<p style="text-align: center;">UNCLASSIFIED</p> <p>1. Recovery 2. Computers 3. Global Search I. AFSC Project No. 7993 II. Fanning, Russell III. In ASTIA collection.</p>

<p style="text-align: center;">UNCLASSIFIED</p> <p>Air Proving Ground Center, Eglin Air Force Base, Florida Rpt. No. AFPGC-TDR-62-44, GLOBAL SEARCH AND RECOVERY. A Feasibility Study of Computer Simulation, Final report, November 1962, 47p. includes tables. Unclassified Report</p> <p>The subject of computer simulation was chosen for this feasibility study as this aspect does not appear to have been well covered during previous studies of the Global Search and Recovery problem. A mathematical model was constructed of a simulated search and recovery mission, and a computer program was constructed which embodied this model. The objective of this computer program was the determination of the probability of successfully retrieving a downed object when given information as to the probable location, the nature and deployment of search and recovery facilities, and a geographic and political description of the earth. Considerable attention was given to developing a convenient means of entering and varying the parameters of the model in a systematic manner. The results of this study indicate that it would be feasible to construct a computer model of at least certain aspects of the search and recovery problem which would be suitable for studies of the effects of several parameters. However, the model described is believed to be too limited and inflexible in form (though not in parameter values) to permit generalization to a larger variety of search and recovery problems. Future work along this line should probably employ a Monte Carlo type approach.</p>	<p style="text-align: center;">UNCLASSIFIED</p> <p>1. Recovery 2. Computers 3. Global Search I. AFSC Project No. 7903 II. Fanning, Russell III. In ASTIA collection.</p>
<p style="text-align: center;">UNCLASSIFIED</p> <p>Air Proving Ground Center, Eglin Air Force Base, Florida Rpt. No. AFPGC-TDR-62-44, GLOBAL SEARCH AND RECOVERY. A Feasibility Study of Computer Simulation, Final report, November 1962, 47p. includes tables. Unclassified Report</p> <p>The subject of computer simulation was chosen for this feasibility study as this aspect does not appear to have been well covered during previous studies of the Global Search and Recovery problem. A mathematical model was constructed of a simulated search and recovery mission, and a computer program was constructed which embodied this model. The objective of this computer program was the determination of the probability of successfully retrieving a downed object when given information as to the probable location, the nature and deployment of search and recovery facilities, and a geographic and political description of the earth. Considerable attention was given to developing a convenient means of entering and varying the parameters of the model in a systematic manner. The results of this study indicate that it would be feasible to construct a computer model of at least certain aspects of the search and recovery problem which would be suitable for studies of the effects of several parameters. However, the model described is believed to be too limited and inflexible in form (though not in parameter values) to permit generalization to a larger variety of search and recovery problems. Future work along this line should probably employ a Monte Carlo type approach.</p>	<p style="text-align: center;">UNCLASSIFIED</p> <p>1. Recovery 2. Computers 3. Global Search I. AFSC Project No. 7903 II. Fanning, Russell III. In ASTIA collection.</p>
<p style="text-align: center;">UNCLASSIFIED</p> <p>Air Proving Ground Center, Eglin Air Force Base, Florida Rpt. No. AFPGC-TDR-62-44, GLOBAL SEARCH AND RECOVERY. A Feasibility Study of Computer Simulation, Final report, November 1962, 47p. includes tables. Unclassified Report</p> <p>The subject of computer simulation was chosen for this feasibility study as this aspect does not appear to have been well covered during previous studies of the Global Search and Recovery problem. A mathematical model was constructed of a simulated search and recovery mission, and a computer program was constructed which embodied this model. The objective of this computer program was the determination of the probability of successfully retrieving a downed object when given information as to the probable location, the nature and deployment of search and recovery facilities, and a geographic and political description of the earth. Considerable attention was given to developing a convenient means of entering and varying the parameters of the model in a systematic manner. The results of this study indicate that it would be feasible to construct a computer model of at least certain aspects of the search and recovery problem which would be suitable for studies of the effects of several parameters. However, the model described is believed to be too limited and inflexible in form (though not in parameter values) to permit generalization to a larger variety of search and recovery problems. Future work along this line should probably employ a Monte Carlo type approach.</p>	<p style="text-align: center;">UNCLASSIFIED</p> <p>1. Recovery 2. Computers 3. Global Search I. AFSC Project No. 7903 II. Fanning, Russell III. In ASTIA collection.</p>
<p style="text-align: center;">UNCLASSIFIED</p> <p>Air Proving Ground Center, Eglin Air Force Base, Florida Rpt. No. AFPGC-TDR-62-44, GLOBAL SEARCH AND RECOVERY. A Feasibility Study of Computer Simulation, Final report, November 1962, 47p. includes tables. Unclassified Report</p> <p>The subject of computer simulation was chosen for this feasibility study as this aspect does not appear to have been well covered during previous studies of the Global Search and Recovery problem. A mathematical model was constructed of a simulated search and recovery mission, and a computer program was constructed which embodied this model. The objective of this computer program was the determination of the probability of successfully retrieving a downed object when given information as to the probable location, the nature and deployment of search and recovery facilities, and a geographic and political description of the earth. Considerable attention was given to developing a convenient means of entering and varying the parameters of the model in a systematic manner. The results of this study indicate that it would be feasible to construct a computer model of at least certain aspects of the search and recovery problem which would be suitable for studies of the effects of several parameters. However, the model described is believed to be too limited and inflexible in form (though not in parameter values) to permit generalization to a larger variety of search and recovery problems. Future work along this line should probably employ a Monte Carlo type approach.</p>	<p style="text-align: center;">UNCLASSIFIED</p> <p>1. Recovery 2. Computers 3. Global Search I. AFSC Project No. 7903 II. Fanning, Russell III. In ASTIA collection.</p>