

UNCLASSIFIED

AD **295 458**

*Reproduced
by the*

**ARMED SERVICES TECHNICAL INFORMATION AGENCY
ARLINGTON HALL STATION
ARLINGTON 12, VIRGINIA**



UNCLASSIFIED

NOTICE: When government or other drawings, specifications or other data are used for any purpose other than in connection with a definitely related government procurement operation, the U. S. Government thereby incurs no responsibility, nor any obligation whatsoever; and the fact that the Government may have formulated, furnished, or in any way supplied the said drawings, specifications, or other data is not to be regarded by implication or otherwise as in any manner licensing the holder or any other person or corporation, or conveying any rights or permission to manufacture, use or sell any patented invention that may in any way be related thereto.

62-118

AD No. 295 458

A PULSED ULTRASONIC THERMOANEMETER

By

N. P. Fateyev

295458

UNEDITED ROUGH DRAFT TRANSLATION

A PULSED ULTRASONIC THERMOANEMOTER

BY: N. P. Fateyev

English Pages: 3

SOURCE: Russian Patent Nr. 134920 (645314/26),
21 November 1959.

SOV/19-61-0-1-76/106

THIS TRANSLATION IS A RENDITION OF THE ORIGINAL FOREIGN TEXT WITHOUT ANY ANALYTICAL OR EDITORIAL COMMENT. STATEMENTS OR THEORIES ADVOCATED OR IMPLIED ARE THOSE OF THE SOURCE AND DO NOT NECESSARILY REFLECT THE POSITION OR OPINION OF THE FOREIGN TECHNOLOGY DIVISION.

PREPARED BY:

TRANSLATION SERVICES BRANCH
FOREIGN TECHNOLOGY DIVISION
WP-APB, OHIO.

A PULSED ULTRASONIC THERMOANEMOMETER

N. P. Fateyev

The well-known instruments for measuring the temperature of an air stream, the velocity of which is measured from the difference in the frequencies of pulse-modulated ultrasonic oscillations propagating in two opposed directions in a close dynamic system, cannot exclude the influence of the stream on the results of the measurement because of possible dynamic heating of the sensitive element, and also the influence of the temperature and humidity of the medium.

The proposed instrument—a pulsed ultrasonic thermoanemometer—based on the same principle of measurement does not have the indicated defects, because a device is used in it which adds the frequencies of pulse repetition in two channels.

The pulsed ultrasonic thermoanemometer shown in the drawing comprises oscillator 1, two controlled cascades 2, to which are connected ultrasonic pulse generators 3, two amplifiers 4 with two sound receivers 5 as their input, and meters for the difference 6 and sum 7 of the frequencies of the oscillations entering both channels.

When an ultrasonic pulse reaches one of the sound receivers there appears at the input of the amplifier a signal which cuts off the

respective controlled cascade of the generator. When ultrasonic pulse reception is interrupted the output cascade is triggered and gives the following ultrasonic pulse. The interval between repetitions and the frequency of the pulses in each channel will be determined by the passage time from the sonic generator to the receiver, as a result of which influence of the stream on the temperature measurement is excluded.

Subject of Invention

A pulsed ultrasonic thermoanemometer in which the velocity of a stream is measured from the difference between the frequencies of pulse-modulated ultrasonic oscillations propagating in two opposed directions in a closed dynamic system, differing in that in order to exclude the effect of the stream on the temperature measurement a device is used for summing the above mentioned frequencies of pulse repetition in the channels.

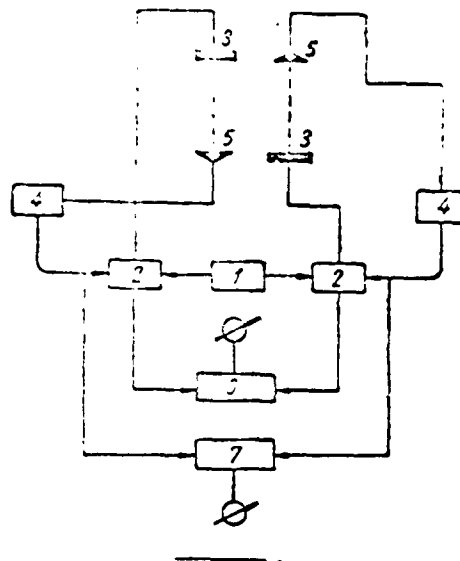

DISTRIBUTION LIST

DEPARTMENT OF DEFENSE	Nr. Copies	MAJOR AIR COMMANDS	Nr. Copies
		AFSC	
		SCFTR	1
		ASTIA	25
HEADQUARTERS USAF		TD-B1a	5
		TD-B1b	3
AFCIN-3D2	1	AEDC (AEY)	1
ARL (ARB)	1	SSD (SSF)	2
		ESD (ESY)	1
		RADC (RAY)	1
		AFSWC (SWF)	1
OTHER AGENCIES		AFMTC (MTW)	1
		BSD (BSF)	1
		AFFTC (FTY)	1
CIA	1		
NSA	6		
AED	2		
OPS	2		
AEC	2		
PWS	1		
NASA	1		
RAND	1		