

UNCLASSIFIED

AD NUMBER
AD295647
NEW LIMITATION CHANGE
TO Approved for public release, distribution unlimited
FROM Distribution authorized to U.S. Gov't. agencies and their contractors; Foreign Government Information; SEP 1962. Other requests shall be referred to British Embassy, 3100 Massachusetts Avenue, NW, Washington, DC 20008.
AUTHORITY
DSTL, AVIA 6/20049, 13 Aug 2008

THIS PAGE IS UNCLASSIFIED

**UNCLASSIFIED**

---

---

**AD 295 647**

*Reproduced  
by the*

**ARMED SERVICES TECHNICAL INFORMATION AGENCY  
ARLINGTON HALL STATION  
ARLINGTON 12, VIRGINIA**



---

---

**UNCLASSIFIED**

NOTICE: When government or other drawings, specifications or other data are used for any purpose other than in connection with a definitely related government procurement operation, the U. S. Government thereby incurs no responsibility, nor any obligation whatsoever; and the fact that the Government may have formulated, furnished, or in any way supplied the said drawings, specifications, or other data is not to be regarded by implication or otherwise as in any manner licensing the holder or any other person or corporation, or conveying any rights or permission to manufacture, use or sell any patented invention that may in any way be related thereto.

REPORT  
CHEM. 536  
295647

REPORT  
CHEM. 536

CATALOGED BY ASTIA  
AS AD No.

295647

ROYAL AIRCRAFT ESTABLISHMENT  
(FARNBOROUGH)

REPORT No. CHEM. 536

RAIN EROSION PART V

DEVELOPMENT OF THE ARTIFICIAL  
RAINFIELD ON THE HIGH SPEED  
TRACK AT P. & E. PENDINE

by

A. A. Fyall, B.Sc. and R. B. King

SEPTEMBER, 1962



NO OTS

THE RECIPIENT IS WARNED THAT INFORMATION  
CONTAINED IN THIS DOCUMENT MAY BE SUBJECT  
TO PRIVATELY-OWNED RIGHTS.

MINISTRY OF AVIATION, LONDON. W.C.2

UNCLASSIFIED

U.D.C. No. 620.193.15 : 629.19.091.31 : 551.578.1

Report No. Chem.536

September, 1962

ROYAL AIRCRAFT ESTABLISHMENT

(FARNBOROUGH)

RAIN EROSION PART V

DEVELOPMENT OF THE ARTIFICIAL RAINFIELD ON THE  
HIGH SPEED TRACK AT P. & E.E. PENDINE

by

A.A. Fyall, B.Sc.  
and  
R.B. King

R.A.E. Ref: Chem/890/RBK

---

SUMMARY

This report discusses the development of the artificial rainfield for rain erosion testing at supersonic velocities on the high speed test track at the Proof and Experimental Establishment, Pendine.

The selection of the nozzles used, their installation in the 500 ft long artificial rainfield, the final calibration of the complete facility are described, together with details of the equipment and operating conditions.

---

UNCLASSIFIED

<u>LIST OF CONTENTS</u>		<u>Page</u>
1	INTRODUCTION	4
2	DESCRIPTION OF THE TRACK AND SITING OF THE RAINFIELD	4
3	CHOICE OF NOZZLE	4
	3.1 Design considerations	4
	3.2 Type	4
4	TEST CONDITIONS FOR NOZZLE CALIBRATIONS	5
	4.1 Open air	5
	4.1.1 Test site and equipment	5
	4.1.2 Rainfall determination	5
	4.1.3 Effect of varying nozzle position	5
	4.1.4 Effect of wind	5
	4.2 Enclosed conditions	6
	4.2.1 Test site and equipment	6
	4.2.2 Effect of varying flow rate	6
	4.2.3 Acceptance tests for individual nozzles	6
5	CALCULATION OF THE NUMBER AND DISTRIBUTION OF NOZZLES	6
	5.1 Rainfall intensity and length of rainfield	6
	5.2 Flow rates and required pressures	7
6	INSTALLATION OF RAINFIELD AND ANCILLARY EQUIPMENT	7
	6.1 Artificial rainfield	7
	6.1.1 Scaffolding and nozzle assemblies	7
	6.1.2 Reservoir and storage tanks	7
	6.1.3 Supply and header mains	7
	6.2 Ancillary equipment	8
	6.2.1 Pumping methods and equipment	8
	6.2.2 Flowmeters	8
7	CALIBRATION OF RAINFIELD	8
	7.1 Sampling by sections	8
	7.2 Continuous monitoring through the rainfield	8
	7.3 Drop size analysis	9
	7.4 Effect of wind and the installation of windshields	9
	7.5 Typical test conditions	10
8	CONCLUSIONS	10
	ACKNOWLEDGMENTS	10
	LIST OF REFERENCES	11
	ADVANCE DISTRIBUTION LIST	12
	TABLES 1-3	13-15
	ILLUSTRATIONS - Figs. 1-9	
	DETACHABLE ABSTRACT CARDS	

<u>Table</u>	<u>LIST OF TABLES</u>	<u>Page</u>
1	Rainfall calibration along the track - Sections 1 and 2	13
2	Rainfall calibration along the track - Sections 3 and 4	14
3	Rainfall calibration along the track - Sections 5 and 6	15

	<u>LIST OF ILLUSTRATIONS</u>	<u>Fig.</u>
Dimensions of nozzle		1
Rainfall distribution from one nozzle		2
Variation of rainfall along track with change in wind direction		3
Drop size distribution along centre line		4
Theoretical rainfall distribution from nozzles 4 ft 6 in. apart		5
Typical trace from the tilting siphon recorder		6
Rain measuring equipment		7
Rain measuring equipment in position on the track		8
Artificial rainfield showing windshield in position on the north side of the track		9

## 1 INTRODUCTION

Rain erosion testing on a rotating arm at speeds up to 500 mile/h has been described previously<sup>1,2,3,4</sup>. A similar technique is being developed for velocities up to 900 mile/h but engineering problems remain to be overcome. The practical limitations of this method are the large increase in power required for a relatively small increase in velocity, and the high centrifugal forces imposed on the specimens. To avoid these difficulties it was decided to make use of the high speed rocket runway at the Proof and Experimental Establishment at Pendine as a test facility for velocities up to 1200 mile/h. This Report describes the development and installation of the artificial rainfield from the initial stages to its current use.

## 2 DESCRIPTION OF THE TRACK AND SITING OF THE RAINFIELD

The track is 3000 ft long of one foot gauge and is equipped with comprehensive communication, instrumentation and control systems. The direction of the track is  $96^{\circ}49'$  (true) i.e. virtually east-west, with the prevailing wind from the south-west.

An examination of typical velocity-distance curves<sup>5</sup> for the rocket propelled vehicle used in these tests showed that the maximum, near constant, velocity was reached between 900 and 1400 ft from the firing point. Accordingly the artificial rainfield was sited in this region. Ideally the nozzles would have been positioned on both sides of the track but an access road on the north side prevented this.

## 3 CHOICE OF NOZZLE

### 3.1 Design considerations

It is necessary in rain erosion testing to simulate as closely as possible, in respect to droplet sizes the rainfall occurring under natural conditions. For the 500 mile/h whirling arm facility at Farnborough a spinning-disco technique was adopted<sup>1</sup>, which closely simulates the drop size spectrum of 1 in/h natural rainfall. As it has been proved that erosion resistance is directly proportional to the rate of rainfall<sup>3</sup>, higher intensities than 1 in/h are used the drop-size spectrum remaining constant.

Since it was impracticable to use spinning discs to provide a uniform rainfield over approximately 500 ft effort was concentrated on the selection of a suitable design of nozzle. Numerous nozzles, commercially obtainable, designed primarily for industrial and horticultural use were evaluated and rejected as unsuitable. Drop size spectra showed no relationship to natural rainfall and rainfall distribution was irregular. Reproducibility from nozzle to nozzle was poor and too great a proportion of mist was produced.

### 3.2 Type

Experience in the U.S.A.<sup>6,7</sup> has indicated that nozzles machined with a countersunk baffle or with a V-shaped slot in the end gave the best results. Several prototypes were therefore made and evaluated. The final choice was a nozzle consisting of a hemispherical end with a V-shaped slot as shown in

Fig. 1. The dimensions and quality of machining were found to be extremely critical, as the presence of machining grooves or burrs caused turbulence within the nozzle, resulting in irregular rainfall distribution and production of large quantities of mist. A batch of 150 brass nozzles were made to this design (Fig. 1).

#### 4 TEST CONDITIONS FOR NOZZLE CALIBRATIONS

##### 4.1 Open air

###### 4.1.1 Test site and equipment

Nozzles were initially evaluated on an open flat area on the roof of Chemistry Department building. It was soon apparent, however, that wind was an important variable and difficulty was encountered in keeping the test conditions reasonably constant, in this open position.

The nozzles were attached to a short length of metal pipe and connected to the mains supply, via a flowmeter, by means of flexible rubber hose. The nozzle assembly was clamped to a retort stand; the position, angle of elevation and height above the ground could all be varied. For sampling the rainfall, a tarpaulin marked in 3ft squares was spread out in the test area and glass beakers placed at the intersections.

###### 4.1.2 Rainfall intensity determination

A typical test consisted of running the water for 10 or 15 minutes at the constant flow rate of 88 gal/h found by experience to be of the correct order to simulate the drop size spectrum for 1 in/h intensity.

The volume of water collected in the beakers was measured, and converted to a rainfall intensity. For ease of calculation, beakers of standard cross sectional area were used. A plot of the typical rainfall distribution obtained from one such test is shown in Fig. 2.

###### 4.1.3 Effect of varying nozzle position

Fig. 2 shows that there is an elliptical area of fairly uniform, high intensity rainfall approximately 9 ft from the nozzle; the intensity falls off rapidly towards the edges of the rainfall area. The nozzle assembly was inclined at  $50^\circ$  to the horizontal and 4 ft above the test area. Decreasing the angle of elevation increased the rainfall area, with lower intensity farther from the nozzle; increasing the angle had the reverse effect. In both cases the rainfall distribution was less uniform than for  $50^\circ$  inclination. Accordingly, for the final installation on the track the nozzle positions were standardised at this angle, 4 ft above and 9 ft horizontally from the centre line of the track.

###### 4.1.4 Effect of wind

As indicated previously rainfall distribution patterns were found to be extremely sensitive to the wind. For wind velocities of up to 10 ft/s in the

same direction as the plane of the nozzle axis the effect was merely to displace the rainfield. In a wind in the opposite direction the rainfield was displaced towards the nozzle but at velocities higher than 5 ft/s the rain was lifted backwards over the nozzle and blown away. Typical plots of rainfall distribution under various conditions are shown in Fig. 3. In view of these difficulties all further calibrations of individual nozzles were made under cover.

#### 4.2 Enclosed conditions

##### 4.2.1 Test site and equipment

All the nozzles were measured to ensure that they complied with Fig. 1 and were otherwise acceptable. Nozzle tests were made under closely controlled conditions in an enclosed building, usually used for accelerated weathering tests by the Clothing and Equipment Physiological Research Establishment.

The test equipment was similar to that described previously with the addition of a pressure vessel and gauge for static pressure recording though in this case no tarpaulin was required as the concrete floor of the structure was suitably marked.

##### 4.2.2 Effect of varying flow rates and pressures

Routine calibration tests were carried out at a static pressure of 12 lb/in<sup>2</sup> and a flow rate of 88 gal/h. The effect of altering the pressure and hence the flow is to produce drops of a different diameter drop sizes decreasing with increase of pressure. Experiments were made between the pressure limits of 10-14 lb/in<sup>2</sup> corresponding to flow rates of 80-95 gal/h. The overall intensity along the centre line is not affected appreciably between these limits but it is more markedly affected around the periphery.

##### 4.2.3 Acceptance tests for individual nozzles

Each nozzle was tested twice for a minimum period of ten minutes. The rainfall at each test station was compared with the standard. The rainfall was examined visually for any local concentrations of large drops or an excess of small drops, producing a mist effect. Drops were sampled by the method used previously<sup>1</sup> using No. 1 Whatman filter paper lightly dusted with Rhodamine dye. The stain diameter produced is approximately five times that of the original drop. Any nozzles not conforming to the required standard were rejected unless the defect such as a machining mark or burr was easily remedied. All 150 nozzles were examined and 125 were found to be satisfactory.

The drop size distribution for one nozzle is shown in Fig. 4. 79 per cent of the drops were found to be between the diameter limits 1.2 to 2.8 mm which is a good approximation to 1 in/h natural rainfall.<sup>1</sup>

## 5 CALCULATION OF THE NUMBER AND DISTRIBUTION OF NOZZLES

### 5.1 Rainfall intensity and length of rainfield

To reduce the number of firings necessary to build up a realistic flight time when testing missile components or to achieve long test times for highly

resistant materials, the nozzles were positioned so that the overall intensity throughout the rainfield was between 5 and 7 in/h. Although rainfalls of this intensity are infrequent under natural conditions, intensities up to 4 in/h are fairly common in the tropics, and since erosion is directly proportional to rate of rainfall, 500 ft of 6 in/h rain can be considered as equivalent to 3000 ft of 1 in/h rain.

Plots were made of theoretical rainfall distributions for standard nozzles placed at various intervals. An interval of 4 ft 6 in. was found to be most suitable for the final installation. For approximately 500 ft of rain 110 nozzles 4 ft 6 in. apart were required. A plot of the theoretical distribution giving a mean intensity of 5.8 in/h along the centre line is shown in Fig. 5.

## 5.2 Flow rates and pressures

Each individual nozzle was calibrated at a flow rate of 88 gal/h and a static pressure of 12 lb/in<sup>2</sup>; for the entire rainfield, therefore, equipment capable of pumping water at a rate of approximately 10,000 gal/h was required.

## 6 INSTALLATION OF RAINFIELD AND ANCILLARY EQUIPMENT

### 6.1 Artificial rainfield

#### 6.1.1 Scaffolding and nozzle assemblies

Steel scaffolding sited on the south side of the track, was used to support the nozzle assemblies, which were fixed by means of adjustable clamps to the top horizontal portion of the scaffolding. Each unit assembly consisted of a nozzle, screwed into a short length of brass tube and connected to a 4 in. diameter header main with 8 ft of flexible rubber hose. When all the nozzles were fixed in position final adjustments were made, using a portable jig which could be moved along the track rails. This ensured that the angle of elevation and the vertical and horizontal distances from the track were correct.

#### 6.1.2 Reservoir and storage tanks

Ample supplies of fresh water are available from a nearby lake. Two storage tanks were installed of total capacity 10,000 gal to give sufficient water for approximately one hour's supply without refilling. At intervals the tanks are drained and cleaned to remove water weed, algae and wind-blown sand as these tend to block the narrow nozzle orifices.

#### 6.1.3 Supply and header mains

A main pipe was laid from the lake to the storage tanks. Twin mains were laid from the storage tanks to the centre of the header main, which ran the whole length of the rainfield. All these mains were of 4 in. internal diameter. Connections were made where necessary with flexible fire hose. The ends of the header main were detachable for drainage purposes to minimise frost damage. For the same reason the supply mains were buried wherever possible or lagged. Three

pressure gauges were installed in the header main, one in the centre and one at each end. During normal testing the pressure reading at the centre was 12 lb/in<sup>2</sup> and, at the ends, 11 lb/in<sup>2</sup>.

## 6.2 Ancillary equipment

### 6.2.1 Pumping methods and equipment

Standard fire fighting equipment was used and operated by the Establishment Fire Service. Either a bowser with twin outlets was available or the pipes were separately connected to two Fire Service Land Rovers. In both cases the pumping pressure was approximately 25 lb/in<sup>2</sup>. The difference in pressure between the pumps and the header main was due to losses in the connecting lines, which were approximately 100 yd long. Pressure losses in the flexible hose were much greater than in the steel main, so these lengths were kept to a minimum. Topping up of the storage tanks was by an auxiliary pump at the lake-side which could be left unattended if large quantities of water were required.

### 6.2.2 Flowmeters

Two Kent Recorder flowmeters were installed, each reading from 0-7000 gal/h. Readings were taken from a chart rotating at one revolution per hour and calibrated in gal/h and minutes.

The instrument was actuated by a difference in pressure between two orifices a short distance apart in the supply main with small bore copper tubing connections to the instrument, the pressure difference being proportional to the rate of flow.

## 7 CALIBRATION OF RAINFIELD

### 7.1 Sampling by sections

Since it was impracticable to measure the whole rainfield simultaneously it was divided into six sections. Cans were placed at 2 ft intervals along the centre line of the track and the rainfield operated for 15 minutes. The volumes collected were measured and are given for the six sections in Tables 1, 2 and 3. Each section was measured at least twice but duplicate runs under identical conditions were difficult to obtain as wind conditions were variable. The limits of wind velocity and direction were noted during each test run.

### 7.2 Continuous monitoring throughout the rainfield

At the front of the mobile rain gauge used for continuous monitoring are two catchment areas, one measuring 36 sq in. and the other 50 sq in. each being 12 in. across, thus enabling a sample to be taken across the full width of the track. The first catchment area is connected to a copper collecting vessel and gives a measure of the average intensity along the track. The other is connected to a tilting siphon recorder. Good agreement between the two was obtained in most cases. For example, Fig. 6 shows a typical trace from the recorder indicating an almost uniform intensity of 7 in/h throughout the rainfield, compared with a collected volume of 270 ml representing a mean intensity

of 6.9 in/h. In this particular case the wind speed was 8 ft/s, direction 225°, and the time in rain 4 minutes. The intensity of the rainfield at any point is calculated from the slope of the curve at that point.

The trolley was hauled by an electrically driven low geared winch, clamped to the track, with a chain drive to a rotating drum on which was wound 525 ft of cable. For each test run the cable was unwound and the trolley pushed back through the rainfield to its starting position. Prior to each run the clockwork mechanism on the recorder was set, a recording chart added, and the siphon primed when necessary.

To ensure that the rainfield was uniform, not only longitudinally, but also across the track, a series of tests was made sampling one third of the width each time. Under similar wind conditions approximately equal amounts of rain were collected.

The rain measuring equipment with the cover removed for clarity is shown in Fig. 7 and in position on the track, together with the winch, in Fig. 8.

### 7.3 Drop size analysis

As each nozzle was individually calibrated prior to installation it was not expected that there would be any marked change in distribution after assembly, but, as a check, drop size samples were taken at intervals throughout the rainfield, using filter paper dusted with Rhodamine dye. The paper was attached to a piece of hardboard 6 in. square which was fixed to a handle 6 ft long. It was inserted face downwards into the rainfield turned upwards for approximately one second, reversed and withdrawn. Subsequently the stain sizes were measured and the drop size distribution calculated. All were found to lie between the required limits shown in Fig. 4, except that there was an excess of smaller drops in the intensity distribution in the centre of the rainfield over that at the ends, because of the higher pressure there (centre 12 lb/in<sup>2</sup>, ends 11 lb/in<sup>2</sup>).

### 7.4 Effect of wind and the installation of wind shields

It was apparent in the early stages of calibration that the rainfield was sensitive to wind variations. The general effect was to displace the rainfield in the direction of the wind. This was not important for low velocity easterly or westerly winds and these displaced the rainfield along the track. However, a wind from the south (i.e. behind the nozzles) displaced the rain beyond the track, and the slightest breeze from the north prevented the rain from reaching the track at all. To a certain extent this effect could be compensated at the expense of varying the drop size by changing the pressure and thus giving the drops a larger or smaller velocity as required (increase of pressure - increase of velocity).

A statistical analysis of the values obtained under known identical conditions (Tables 1, 2 and 3) showed that there was no significant difference between runs for the same section, but there was a difference between different sections under nominally identical conditions. This was accounted for by differences in the local topography of the sand dunes affording varying degrees of protection from the wind.

In order to avoid unacceptable delay in waiting for appropriate wind conditions it was decided to protect the rainfield by erecting corrugated iron sheeting on scaffolding on the north side of the track. Later this was extended to the south side to give greater protection. The facility is now usable with wind velocities up to 35 ft/s from directions between 90 and 270° and up to 10 ft/s from 0-90° and 270-360°. Fig. 9 shows the rainfield in operation protected with sheeting on the north side. The rainfall intensity on this occasion was approximately 5 in/h.

#### 7.5 Typical test conditions

Under ideal conditions the flow was maintained at 10,000 gal/h with a pump pressure of 25 lb/in<sup>2</sup>, each recorder reading approximately 5000 gal/h. Flows from 9000 gal/h to 12,000 gal/h were used to accommodate changing wind conditions. At intervals a rainfall intensity check was made and individual nozzles cleared of obstructions if necessary. These were either observed visually or interpreted from irregularities in the recorded intensity. The pumps were operated for a few minutes until steady flow conditions were obtained and were left unattended for periods up to 10 minutes whilst personnel took cover for a firing. If any undue delays occurred the pumps were turned off to conserve water supplies until the trouble was rectified.

#### 8 CONCLUSIONS

The rainfield facility as described, has been found to be useful for rain simulation under most wind conditions less than 35 ft/s velocity, and has enabled rain erosion tests to be made at supersonic speeds. Had circumstances permitted, a further improvement would have been to instal nozzles on both sides of the track to reduce the dependence on wind conditions still more. This was not practicable with the present facility as nozzles on the north side would have been sited in the centre of the existing roadway which runs the full length of the track. However this point should be noted in the design of any future track incorporating rain erosion testing.

#### ACKNOWLEDGEMENTS

The authors wish to thank Mr. R.G. Ansell, Mr. J.A. Sage and Mr. J.H. Sewell for assistance in carrying out this work, the Director C.E.P.R.E. for use of test facilities at Rushmoor, and the Superintendent and staff at P.&E.E. Pendine. We thank in particular the members of the Establishment Fire Service without whose aid the work would not have been possible.

LIST OF REFERENCES

<u>No.</u>	<u>Author</u>	<u>Title etc.</u>
1	Fyall, A.A. Strain, R.N.C.	A "whirling arm" test rig for the assessment of the rain erosion of materials. R.A.E. Report No. Chem.509, December 1956
2	Fyall, A.A. King, R.B. Strain, R.N.C.	Rain erosion Part II. An assessment of various materials. R.A.E. Report No. Chem.510 April 1957
3	Fyall, A.A. King, R.B. Strain, R.N.C.	Rain erosion Part III. A gravimetric assessment of the erosion resistance of various materials. R.A.E. Report No. Chem.513 September 1957
4	King, R.B.	Rain erosion Part IV. An assessment of various materials. R.A.E. Report No. Chem. 521 September 1960
5	-	Proof and Experimental Establishment Pendine. Trial Report No. KX.17/2/4 - 2/56 February 1956
6	Landsberg, M.I. Moody, F.J.	Devices for producing artificial rainfall for tests of water-repellent and waterproof materials. Textile Research Journal May 1946
7	Raytheon Manufacturing Company	Radome rain erosion testing by means of supersonic sleds. M/R 16-875 May 1956

---

ATTACHED: Tables 1 to 3  
Drawings: Chem. 4119 to 4124  
Negs. 159,254 and 159,255  
Detachable Abstract Cards

ADVANCE DISTRIBUTION:

CA	CI through TIL
Chief Scientist	AID Harefield
DCA RD	NGTE (Pyestock) Dr. R.N.C. Strain
DCW	RRE Malvern Mr. A. Munro
DGSR(A)	Mr. W. Lawson
DGAGS	ERDE (Waltham Abbey) Mr. H. Warburton-Hall
DG(GW)	CS RAE Bedford
D(RN)A	CS RPE Westcott
D(RAF)A	SP & EE Pendine (5 copies)
D(RAF)B	TIL (120 copies)
DA Mech	
D Struct	Director RAE
D Mat	DDRAE(A)
ADSR(A)	DDRAE(E)
AD Mat NI: (3 copies)	Head of Aero Dept
AD/AR	" " Chem. Dept
AD/G <sup>7</sup> G & C	" " ME "
GWG&C - Miss K.F.Earp (12 copies)	" " Met/Phys Dept
DRRE	" " Radio Dept
DRARDE	" " Space Dept
CS A & AEE	" " Weapons Dept
	" " Structures Dept
	Pats 1/RAE
	Library

TABLE 1  
Rainfall calibration along the track-sections 1 and 2

Section 1, Nozzles 1 - 17			Section 2, Nozzles 18 - 35			
Run No.			Run No.			
Windspeed & direction	5-8 ft/s 140°	0-4 ft/s 170-175°	Windspeed & direction	10-12 ft/s 155°	0-2 ft/s 155°	0-2 ft/s 155°
Can No.	Intensity (in/h)	Intensity (in/h)	Can No.	Intensity (in/h)	Intensity (in/h)	Intensity (in/h)
1	0.0	0.6	42	4.6	6.2	5.8
2	0.7	1.6	43	4.1	5.3	5.4
3	1.3	2.8	44	3.9	6.2	6.3
4	2.5	4.0	45	4.0	5.6	5.5
5	3.6	5.1	46	4.0	5.8	6.7
6	5.0	6.5	47	4.1	6.5	7.0
7	6.2	7.0	48	4.6	6.5	6.4
8	6.9	7.4	49	4.3	5.3	5.0
9	7.2	7.8	50	3.6	4.6	5.5
10	8.0	7.5	51	3.4	5.5	6.3
11	7.3	6.8	52	3.9	5.5	6.1
12	6.5	6.6	53	3.9	5.9	6.8
13	6.3	6.6	54	4.0	5.3	5.8
14	5.9	6.6	55	3.6	5.2	6.1
15	6.3	6.3	56	3.4	5.2	5.4
16	5.9	6.2	57	3.2	4.7	6.0
17	6.1	6.4	58	3.4	5.8	6.8
18	6.0	6.3	59	3.8	6.0	6.9
19	6.0	6.3	60	3.7	4.5	7.0
20	6.2	6.6	61	3.7	5.5	6.0
21	6.3	6.8	62	3.6	5.5	6.3
22	6.4	6.1	63	3.5	4.6	4.7
23	6.1	6.1	64	3.1	4.7	6.1
24	5.8	6.0	65	3.1	5.6	6.0
25	5.7	6.2	66	3.3	4.6	5.9
26	5.8	6.3	67	3.4	4.8	5.5
27	5.7	6.4	68	3.2	4.3	5.3
28	6.1	7.0	69	3.1	4.9	6.2
29	6.5	6.9	70	3.4	4.2	5.8
30	6.2	6.6	71	3.3	5.4	6.3
31	6.2	6.8	72	3.3	5.0	5.1
32	6.3	7.0	73	3.0	4.4	5.6
33	6.8	6.9	74	2.8	4.9	5.6
34	6.4	6.7	75	3.0	4.9	5.8
35	6.4	7.1	76	3.1	5.1	5.7
36	6.4	6.7	77	3.1	4.7	6.0
37	6.8	6.6	78	3.1	5.3	6.4
38	6.1	6.6	79	3.0	4.9	4.8
39	5.9	6.6	80	3.1	4.5	5.8
40	6.2	6.6	81	3.1	5.0	5.6
41	6.6	6.6	82	3.1	4.6	6.0
Mean	5.7	6.2	Mean	3.5	5.2	5.9

TABLE 2

Rainfall calibration along the track - sections 3 and 4

Section 3, Nozzles 36 - 53			Section 4, Nozzles 54 - 71			
Run No.	1	2	Run No.	1	2	3
Windspeed & direction	0-2 ft/s 170°	0-2 ft/s 160-170°	Windspeed & direction	>2 ft/s 170°	5-10 ft/s 135°	6-8 ft/s 140°-160°
Can No.	Intensity (in/h)	Intensity (in/h)	Can No.	Intensity (in/h)	Intensity (in/h)	Intensity (in/h)
83	5.2	5.1	124	5.5	4.7	4.3
84	5.6	5.9	125	5.3	4.6	4.7
85	5.9	5.9	126	6.0	4.6	4.5
86	6.3	6.5	127	5.4	4.7	4.4
87	6.4	6.4	128	6.1	4.0	3.8
88	6.7	6.9	129	6.6	4.5	3.8
89	6.3	6.1	130	6.7	4.6	4.0
90	5.8	6.1	131	6.7	5.0	4.1
91	5.6	5.3	132	6.8	4.9	4.3
92	5.2	5.6	133	6.8	5.0	4.3
93	5.7	5.9	134	7.0	5.0	4.3
94	5.5	5.7	135	6.8	5.0	4.3
95	5.7	6.1	136	6.4	4.6	4.5
96	5.8	6.0	137	6.7	4.6	4.1
97	5.8	6.0	138	6.6	4.7	4.0
98	5.8	6.0	139	6.3	4.9	4.2
99	5.7	6.4	140	6.7	4.9	4.5
100	6.0	6.3	141	7.0	5.4	4.4
101	6.2	6.5	142	6.6	5.3	4.7
102	5.9	5.9	143	6.7	5.2	4.8
103	6.3	5.9	144	6.0	5.2	4.7
104	5.7	6.0	145	6.3	4.9	4.7
105	5.8	6.0	146	6.8	5.0	4.5
106	5.7	6.0	147	6.8	5.4	5.0
107	5.8	5.9	148	6.4	5.3	5.0
108	5.8	6.2	149	5.2	4.9	4.9
109	5.9	5.9	150	5.7	4.7	4.3
110	5.6	5.9	151	5.8	4.8	4.3
111	5.9	5.9	152	6.4	4.8	4.3
112	6.3	6.1	153	6.8	4.9	4.3
113	5.9	5.9	154	6.9	5.1	4.5
114	6.0	6.5	155	6.0	5.2	4.7
115	6.4	6.5	156	6.4	4.9	4.7
116	6.4	6.2	157	6.5	4.9	4.3
117	6.1	6.2	158	6.7	5.0	4.6
118	6.3	6.5	159	7.2	5.0	4.5
119	6.7	6.8	160	7.0	5.5	4.8
120	6.9	7.8	161	6.3	5.4	4.8
121	6.6	7.8	162	6.4	5.1	4.7
122	6.0	7.0	163	6.6	5.2	5.0
123	5.9	5.8	164	6.1	5.2	4.7
Mean	6.0	6.2	Mean	6.4	4.9	4.5

TABLE 3  
Rainfall calibration along the track section 5 and 6

Section 5, Nozzles 72-90			Section 6, Nozzles 91-110		
Run No.	1	2	Run No.	1	2
Windspeed & direction	6-8 ft/s 140-150°	15 ft/s 150°	Windspeed & direction	10-15 ft/s 140-160°	8-12 ft/s 150-170°
Can No.	Intensity (in/h)	Intensity (in/h)	Can No.	Intensity (in/h)	Intensity (in/h)
165	5.6	2.8	206	4.8	4.5
166	5.4	2.7	207	4.9	4.5
167	5.6	2.8	208	4.5	4.2
168	5.3	2.8	209	4.3	4.3
169	5.4	2.8	210	4.7	4.7
170	5.8	3.3	211	4.8	4.6
171	5.8	4.2	212	4.8	4.7
172	5.7	3.8	213	4.8	4.7
173	6.1	3.6	214	4.9	4.7
174	6.2	3.6	215	5.1	5.1
175	5.5	3.7	216	5.3	4.9
176	5.4	3.6	217	5.2	4.7
177	5.7	3.6	218	5.3	4.5
178	6.2	3.9	219	5.3	4.7
179	6.0	3.6	220	5.6	4.7
180	6.5	4.6	221	5.7	4.8
181	6.3	4.3	222	5.8	5.2
182	6.3	4.3	223	5.9	4.2
183	5.9	4.0	224	5.2	3.6
184	5.8	3.8	225	5.3	3.7
185	6.0	4.0	226	5.3	3.9
186	6.0	4.0	227	5.2	3.8
187	6.1	4.0	228	5.2	3.8
188	6.4	3.9	229	5.4	3.9
189	5.9	4.1	230	5.4	4.0
190	5.9	4.0	231	5.4	4.2
191	5.7	3.7	232	5.5	4.0
192	6.3	3.7	233	5.6	4.0
193	6.3	3.6	234	5.5	4.1
194	6.0	3.6	235	5.6	4.0
195	6.5	3.8	236	5.2	2.8
196	6.5	3.9	237	4.4	2.9
197	6.3	3.9	238	4.4	3.2
198	6.2	3.7	239	4.6	3.3
199	6.0	3.6	240	4.7	3.3
200	6.0	4.1	241	4.8	3.2
201	6.2	3.6	242	4.5	3.1
202	6.1	3.5	243	4.1	2.7
203	6.1	3.5	244	3.6	2.2
204	6.2	3.9	245	2.9	1.6
205	6.2	3.8	246	1.8	0.8
Mean	6.0	3.7	Mean	4.9	3.9

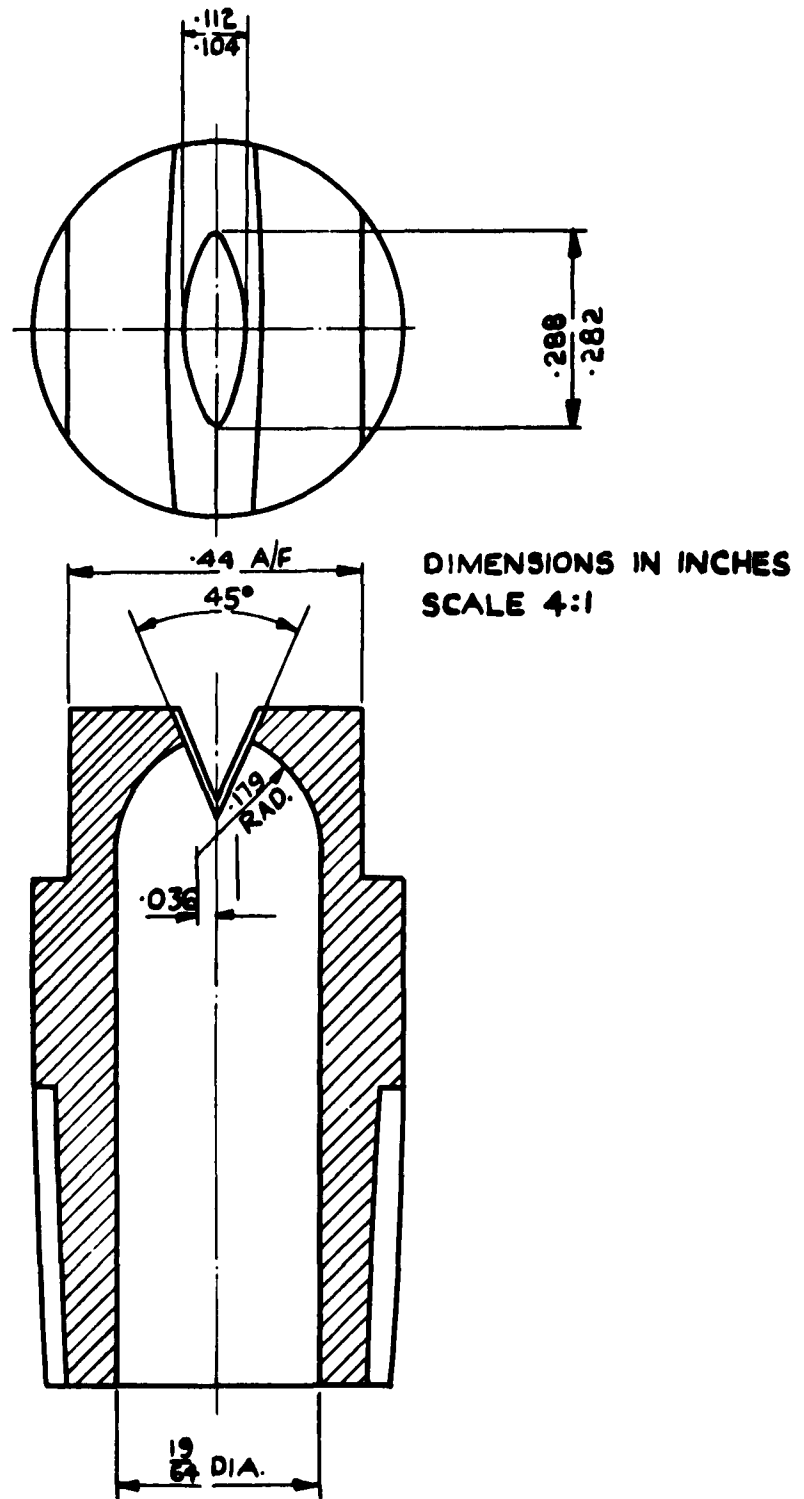

FIG. I. DIMENSIONS OF NOZZLE.

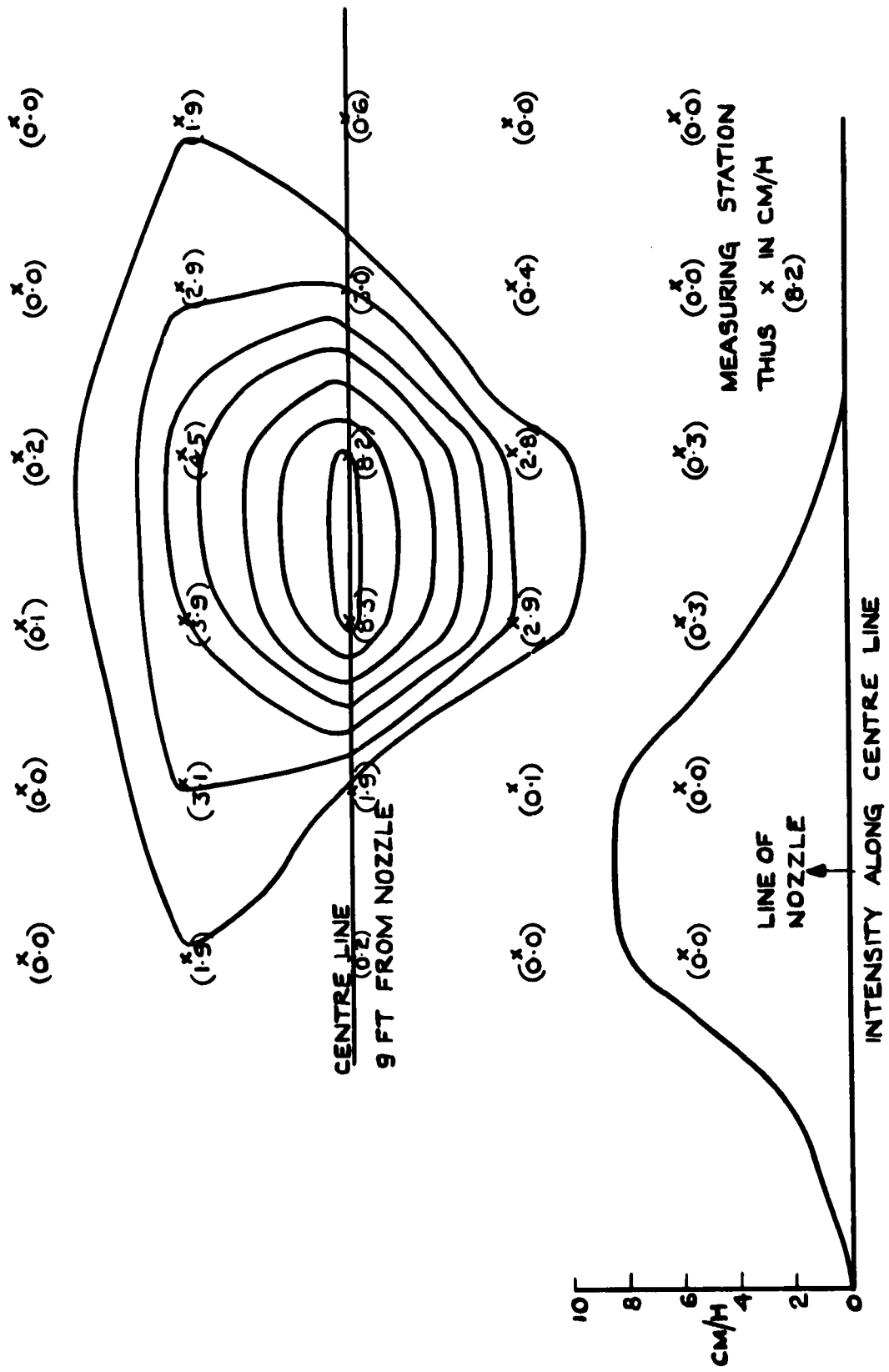

FIG. 2. RAINFALL DISTRIBUTION FROM ONE NOZZLE.

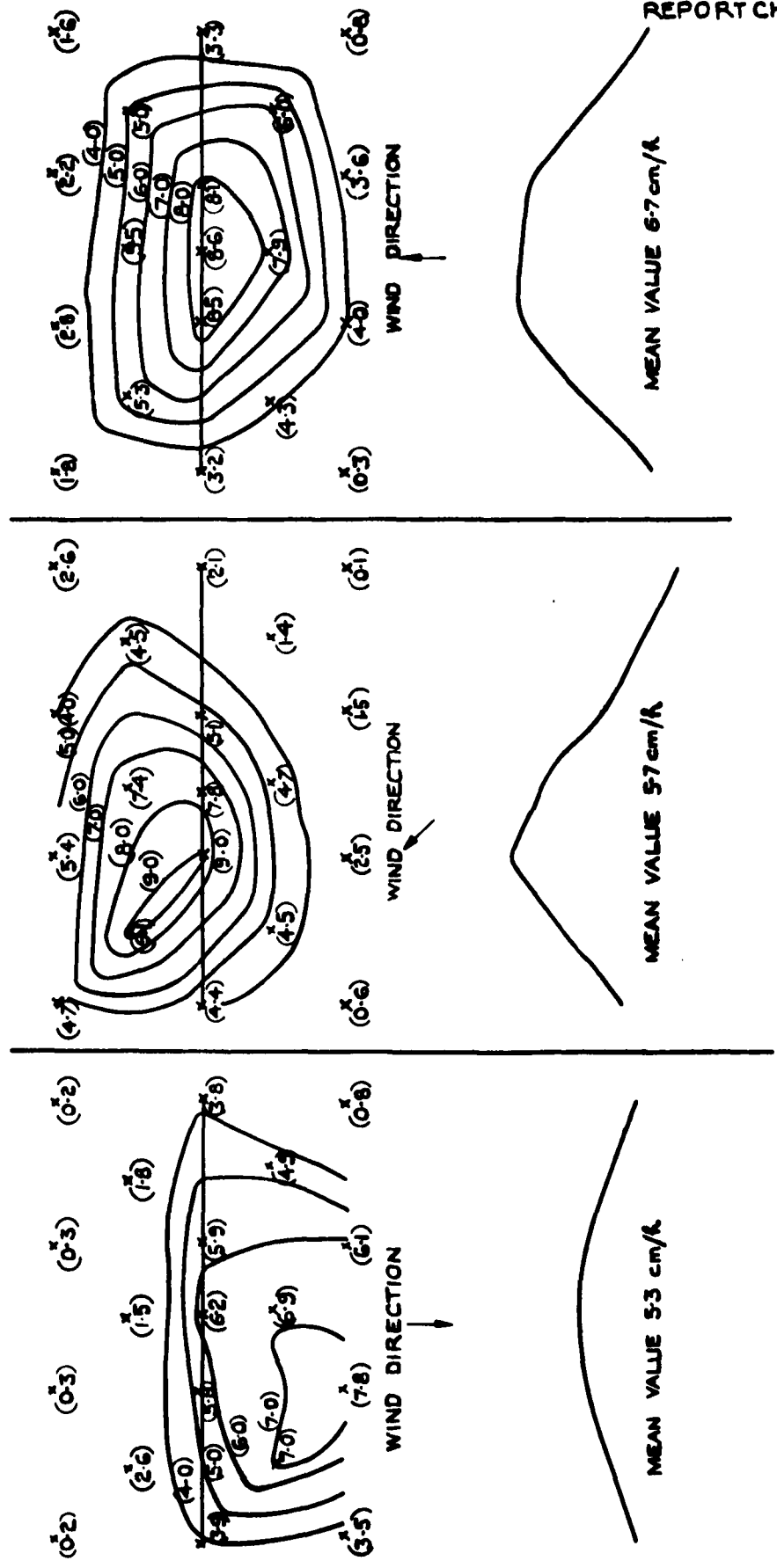

FIG. 3. VARIATION OF RAINFALL ALONG TRACK WITH CHANGE IN WIND DIRECTION  
(CM/H/ - SCALE 1CM = 1FT.)

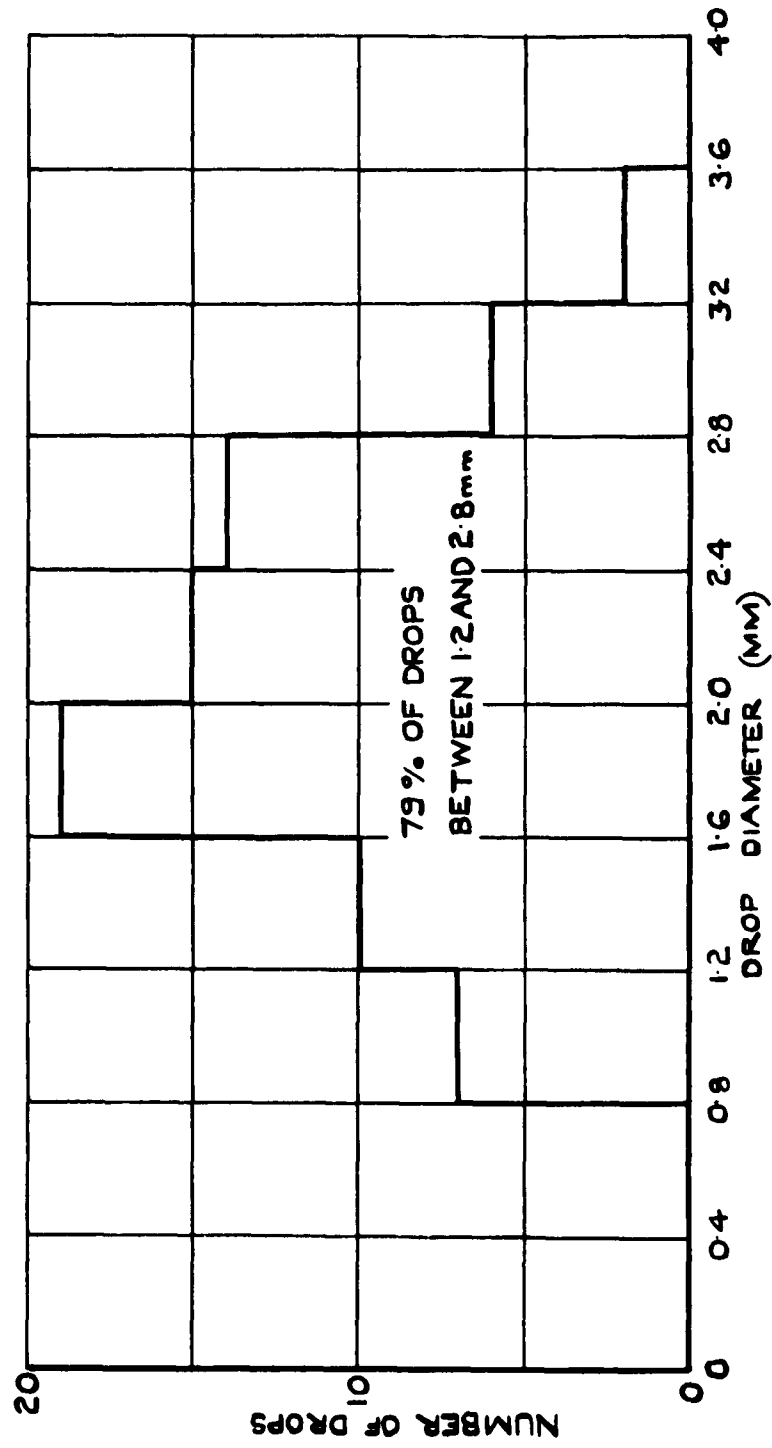
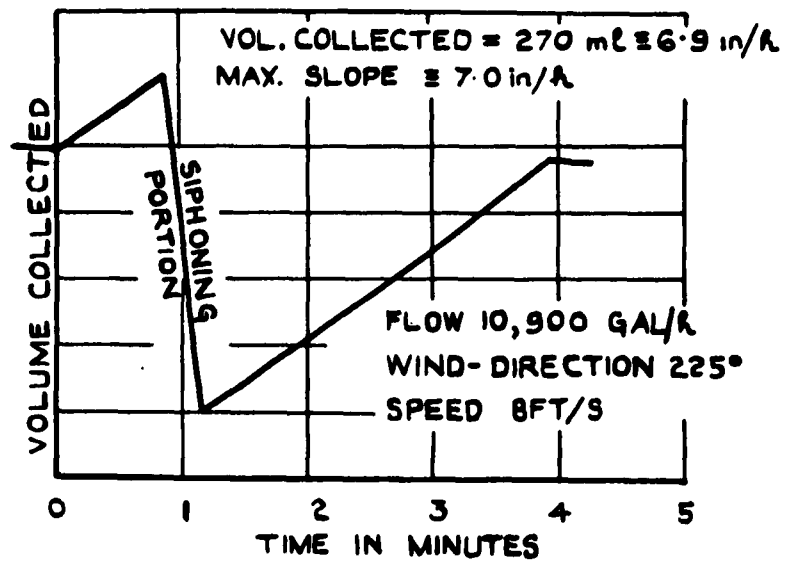

FIG.4. DROP SIZE DISTRIBUTION ALONG CENTRE LINE.





NOTE - VOLUME COLLECTED IN RECORDER IS PROPORTIONAL  
TO CATCHMENT AREA AND RATE OF RAINFALL

FIG. 6. TYPICAL TRACE FROM THE TILTING SIPHON RECORDER.

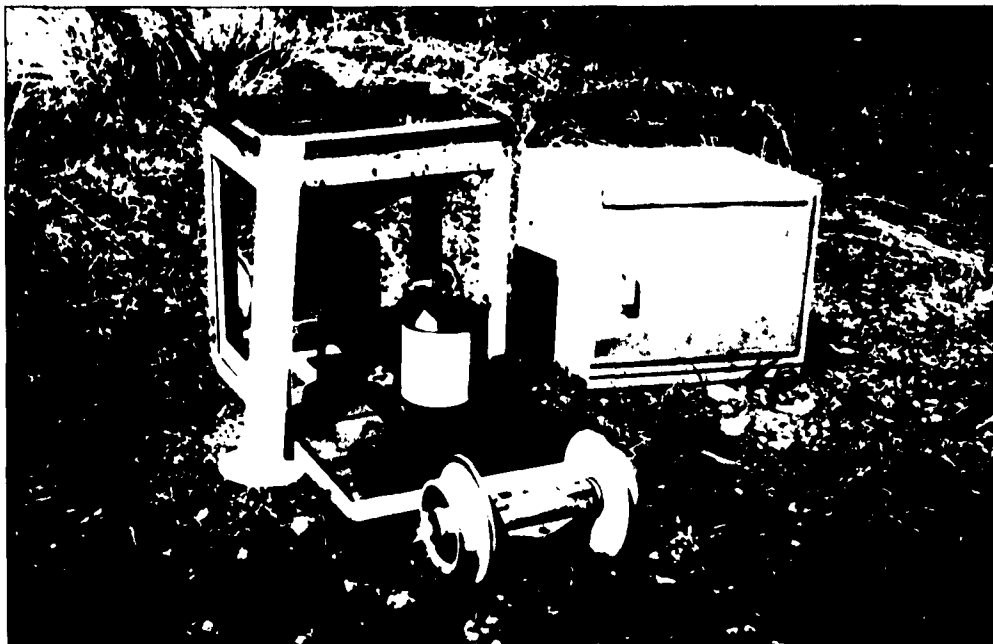

FIG.7. RAIN MEASURING EQUIPMENT

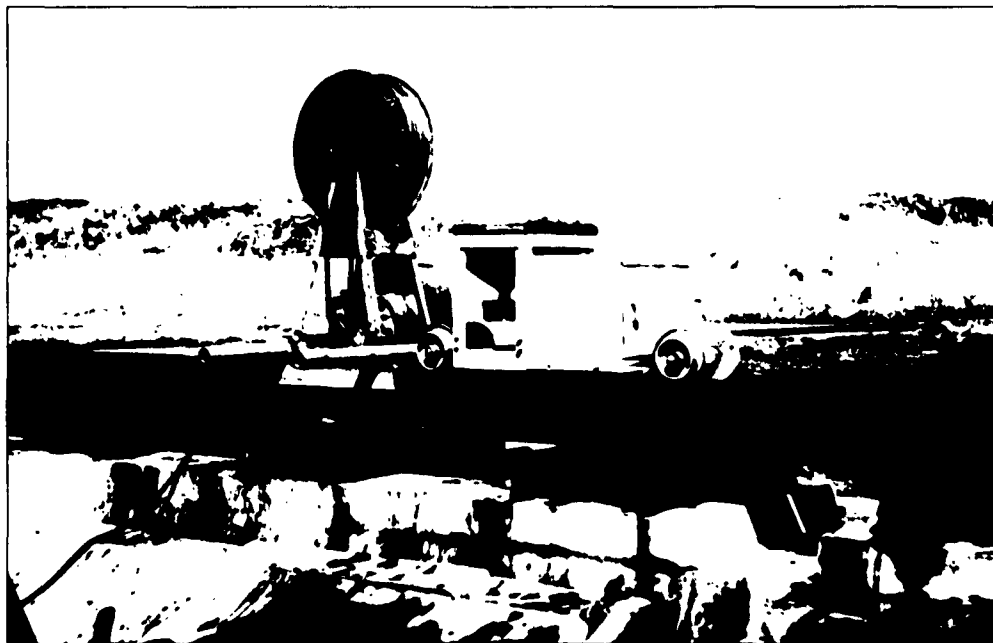

FIG.8. RAIN MEASURING EQUIPMENT IN  
POSITION ON THE TRACK



FIG.9. ARTIFICIAL RAINFIELD SHOWING WINDSHIELD  
IN POSITION ON THE NORTH SIDE OF THE TRACK

DETACHABLE ABSTRACT CARDS

These abstract cards are inserted in Reports and Technical Notes for the convenience of Librarians and other who need to maintain an Information Index.

Detached cards are subject to the same Security Regulations as the parent document, and a record of their location should be made on the inside of the back cover of the parent document.

<p align="center">UNCLASSIFIED</p> <p>Report No. Chm. 536 Royal Aircraft Establishment</p> <p>RAIN EROSION PART V DEVELOPMENT OF THE ARTIFICIAL RAINFIELD ON THE HIGH SPEED TRACK AT P. &amp; E.E. PENDINE. Fyall, A.A. and King R.B. September, 1962</p> <p>This report discusses the development of the artificial rainfield for rain erosion testing at supersonic velocities on the high speed test track at the Proof and Experimental Establishment, Pendine.</p> <p>The selection of the nozzles used, their installation in the 500 ft long artificial rainfield, the final calibration of the complete facility are described, together with details of the equipment and operating conditions.</p>	<p align="center">UNCLASSIFIED</p> <p>Report No. Chm. 536 Royal Aircraft Establishment</p> <p>RAIN EROSION PART V DEVELOPMENT OF THE ARTIFICIAL RAINFIELD ON THE HIGH SPEED TRACK AT P. &amp; E.E. PENDINE. Fyall, A.A. and King R.B. September, 1962</p> <p>This report discusses the development of the artificial rainfield for rain erosion testing at supersonic velocities on the high speed test track at the Proof and Experimental Establishment, Pendine.</p> <p>The selection of the nozzles used, their installation in the 500 ft long artificial rainfield, the final calibration of the complete facility are described, together with details of the equipment and operating conditions.</p>
<p align="center">UNCLASSIFIED</p> <p>Report No. Chm. 536 Royal Aircraft Establishment</p> <p>RAIN EROSION PART V DEVELOPMENT OF THE ARTIFICIAL RAINFIELD ON THE HIGH SPEED TRACK AT P. &amp; E.E. PENDINE. Fyall, A.A. and King R.B. September, 1962</p> <p>This report discusses the development of the artificial rainfield for rain erosion testing at supersonic velocities on the high speed test track at the Proof and Experimental Establishment, Pendine.</p> <p>The selection of the nozzles used, their installation in the 500 ft long artificial rainfield, the final calibration of the complete facility are described, together with details of the equipment and operating conditions.</p>	<p align="center">UNCLASSIFIED</p> <p>Report No. Chm. 536 Royal Aircraft Establishment</p> <p>RAIN EROSION PART V DEVELOPMENT OF THE ARTIFICIAL RAINFIELD ON THE HIGH SPEED TRACK AT P. &amp; E.E. PENDINE. Fyall, A.A. and King R.B. September, 1962</p> <p>This report discusses the development of the artificial rainfield for rain erosion testing at supersonic velocities on the high speed test track at the Proof and Experimental Establishment, Pendine.</p> <p>The selection of the nozzles used, their installation in the 500 ft long artificial rainfield, the final calibration of the complete facility are described, together with details of the equipment and operating conditions.</p>



*Information Centre  
Knowledge Services*  
**[dstl]** Porton Down,  
Salisbury  
Wiltshire  
SP4 0JQ  
22060-6218  
Tel: 01980-613753  
Fax 01980-613970

Defense Technical Information Center (DTIC)  
8725 John J. Kingman Road, Suit 0944  
Fort Belvoir, VA 22060-6218  
U.S.A.

AD#: AD295647

Date of Search: 13 August 2008

Record Summary: AVIA 6/20049

Title: Rain erosion: Pt 5, development of the artificial rainfield on the high speed track at  
Proof & Experimental Establishment, Pendine  
Availability Open Document, Open Description, Normal Closure before FOI Act: 30 years  
Former reference (Department) REPORTS CHEM 536  
Held by The National Archives, Kew

This document is now available at the National Archives, Kew, Surrey, United Kingdom.

DTIC has checked the National Archives Catalogue website (<http://www.nationalarchives.gov.uk>) and found the document is available and releasable to the public.

Access to UK public records is governed by statute, namely the Public Records Act, 1958, and the Public Records Act, 1967. The document has been released under the 30 year rule. (The vast majority of records selected for permanent preservation are made available to the public when they are 30 years old. This is commonly referred to as the 30 year rule and was established by the Public Records Act of 1967).

**This document may be treated as UNLIMITED.**