

UNCLASSIFIED

AD 295 668

*Reproduced
by the*

**ARMED SERVICES TECHNICAL INFORMATION AGENCY
ARLINGTON HALL STATION
ARLINGTON 12, VIRGINIA**



UNCLASSIFIED

NOTICE: When government or other drawings, specifications or other data are used for any purpose other than in connection with a definitely related government procurement operation, the U. S. Government thereby incurs no responsibility, nor any obligation whatsoever; and the fact that the Government may have formulated, furnished, or in any way supplied the said drawings, specifications, or other data is not to be regarded by implication or otherwise as in any manner licensing the holder or any other person or corporation, or conveying any rights or permission to manufacture, use or sell any patented invention that may in any way be related thereto.

63-2-3

AFSWC-TDR-62-54

SWC
TDR
62-54

295 668

FISSION PRODUCTS FIELD RELEASE TEST III

TECHNICAL DOCUMENTARY REPORT NO. AFSWC-TDR-62-54

December 1962

CATALOGUED BY ASTIA
As AD No. _____

295668

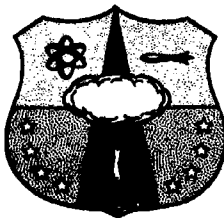

Research Directorate
AIR FORCE SPECIAL WEAPONS CENTER
Air Force Systems Command
Kirtland Air Force Base
New Mexico

Project No. 655A

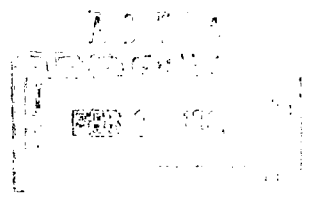

(Prepared under Contract No. AF 29(601)-4581
by Nuclear Aerospace Research Facility, oper-
ated by General Dynamics, Fort Worth, Texas)

**HEADQUARTERS
AIR FORCE SPECIAL WEAPONS CENTER
Air Force Systems Command
Kirtland Air Force Base
New Mexico**

When Government drawings, specifications, or other data are used for any purpose other than in connection with a definitely related Government procurement operation, the United States Government thereby incurs no responsibility nor any obligation whatsoever; and the fact that the Government may have formulated, furnished, or in any way supplied the said drawings, specifications, or other data, is not to be regarded by implication or otherwise as in any manner licensing the holder or any other person or corporation, or conveying any rights or permission to manufacture, use, or sell any patented invention that may in any way be related thereto.

This report is made available for study upon the understanding that the Government's proprietary interests in and relating thereto shall not be impaired. In case of apparent conflict between the Government's proprietary interests and those of others, notify the Staff Judge Advocate, Air Force Systems Command, Andrews AF Base, Washington 25, DC.

This report is published for the exchange and stimulation of ideas; it does not necessarily express the intent or policy of any higher headquarters.

Qualified requesters may obtain copies of this report from ASTIA. Orders will be expedited if placed through the librarian or other staff member designated to request and receive documents from ASTIA.

TDR-62-54

FOREWORD

The General Dynamics/Fort Worth designation of this report is FZK-153.

ABSTRACT

A series of field experiments (FRT-III) was conducted to determine the types and quantities of radioactivity that might be released during the meltdown of a PLUTO-type reactor. Four fission-product releases from the melting of segments of freshly irradiated UO_2 - BeO ceramic unclad fuel elements were made at the National Reactor Testing Station (NRTS) in Idaho during the summer of 1961. The fuel samples were melted in high-temperature induction furnaces; three releases were made into collectors designed to trap 100% of the released fission products (with the exception of the noble gases) and one release was made to the atmosphere.

The experimental design and techniques used in analyzing the data from these tests are described. Experimental results such as release percent, particle-size distribution, air and ground concentration, deposition velocity, and solubility are given.

The quality and value of these data are diminished because of unanticipated difficulties in dissolving the post-melt irradiated fuel pins and mishaps connected with two of the closed release experiments. However, since only sparse data relating to release of fission products from PLUTO fuel elements are available, the experimental results are presented to provide rough indications of fission product release behavior under conditions simulating after-heat melting of the PLUTO core.

PUBLICATION REVIEW

This report has been reviewed and is approved.

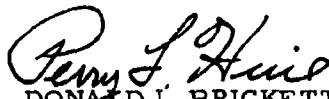
DONALD I. PRICKETT
Colonel USAF
Director, Research Directorate



JOHN J. DISHUCK
Colonel USAF
DCS/Plans & Operations

TABLE OF CONTENTS

	Page
I. INTRODUCTION	1
II. EXPERIMENTAL DESIGN	3
2.1 Test Site	3
2.2 Source of Fission Products	5
2.2.1 Fuel Elements	5
2.2.2 Induction Furnace	5
2.3 Sampling Network	8
2.3.1 Radioactivity-Dispersal Measurements	10
2.3.2 Radioactivity-Deposition Measurements	13
2.3.3 Solubility and Particle-Size Determinations	13
2.4 Total Effluent Collector	16
III. ANALYTICAL TECHNIQUES	21
3.1 Radiochemical Analyses	21
3.1.1 Dissolution Methods	22
3.1.2 Analyses	23
3.2 Gross-Gamma Measurements	24
3.3 Gamma-Ray Spectroscopy	25
3.3.1 Spectral Techniques	25
3.3.2 Spectral Reduction	26

TABLE OF CONTENTS (cont'd)

	Page
3.4 Solubility Determinations	26
3.5 Isotopic-Release Percents from Open-Release Data	28
IV. RESULTS AND DISCUSSION	29
4.1 Synopsis of Field Test Operations	29
4.2 Fuel Irradiation	30
4.3 Release Percents	33
4.3.1 Radiochemical Analyses	33
4.3.2 Open Release	34
4.3.3 Gross-Gamma Determinations	37
4.4 Dispersal of Effluent	39
4.4.1 Activity Release Height	39
4.4.2 Air Concentration	41
4.4.3 Ground Contamination	41
4.4.4 Deposition Velocities	41
4.4.5 Solubility	41
4.4.6 Particle-Size Distribution	46
4.5 Meteorological Conditions Existing During Tests	50
V. SUMMARY AND CONCLUSIONS	53
5.1 Summary	53
5.1.1 Release Percents	53
5.1.2 Particle Size	55
5.1.3 Deposition Velocity	55

TABLE OF CONTENTS (cont'd)

	Page
5.1.4 Solubility	56
5.1.5 Activity Release Heights	57
5.2 Conclusions	57
REFERENCES	59
DISTRIBUTION	61

LIST OF FIGURES

Figure		Page
1	Site Location	4
2	UO ₂ -BeO Ceramic Fuel Element	6
3	Induction Furnace	7
4	Typical Melt-Temperature and Furnace-Power Profiles	9
5	Sampling Network	11
6	Typical Sampling Equipment	12
7	Vertical Sticky-Paper Sampling Station	14
8	Solubility-Sample Filters	15
9	Total-Effluent Collector: Analysis Configuration	17
10	Total-Effluent Collector: Furnace Configuration	18
11	Typical Gamma Spectrum	27
12	Activity Release Height on 45-Meter Arc	40
13	Air Concentration Isopleths	42
14	Ground-Contamination Isopleths	43
15	Solubility of Various Isotopes in Distilled Water and 0.5% by Volume Aqueous HCl	45
16	Percent Isotopic Activity per Stage (50-Meter Arc)	47
17	Andersen Sampler Calibration	49

LIST OF TABLES

Table		Page
1	Fuel Element Test Data	31
2	Inventory at End of Irradiation	32
3	Release Percents Based on Phillips Petroleum Co. Data	34
4	Uranium and Beryllium Analysis	35
5	Radiochemical Analysis	36
6	Release Percents Based on Open Release Data	37
7	Release Percents Calculated from Gross Gamma Measurements	38
8	Average Deposition Velocities	44
9	Percent of Andersen Sampler Activity Collected by Each Stage	48
10	Summary of Release Conditions	51
11	Release Percents from FRT-I, -II, and -III	54
12	Summary of Particle Size Data - 50-Meter Arc	55
13	Deposition Velocities from FRT-I, -II, and -III	56

I. INTRODUCTION

The combination of high power-density, high operating temperature, and high-velocity gas coolant is such that the PLUTO reactor system is particularly susceptible to failure if coolant flow is disrupted. Even if the reactor is made subcritical at the instant of flow interruption, the afterheat from fission-product decay will cause the core to melt if typical heat-transfer conditions prevail. As an aid in predicting the types and quantities of radioactivity that might be released during core melting, a series of field experiments (FRT-III) was conducted in which irradiated PLUTO-type fuel elements were used.

The test series consisted of three closed melts in which 100% of the effluent was collected and analyzed to determine types and percentages of fission products released and one open release in which the effluent was dispersed onto a sampling network. Analyses of the samples collected during the open release were performed to determine fission-product particle size, relative release fractions, solubility, and dispersal characteristics.

This report describes the experiments, the physical equipment, the test site, and the methods used to measure fission-product release and atmospheric dispersal resulting from the melting of PLUTO-type ceramic fuel elements. Analyses of the data are made and results are presented.

II. EXPERIMENTAL DESIGN

This series of field releases of fission products (FRT-III), performed at the National Reactor Testing Station (NRTS) in Idaho during the summer of 1961, was designed to simulate the slow melt-down and release of fission products from fuel elements of the PLUTO type.

Since atmospheric diffusion of fission products had been studied in two previous test series (Refs. 1 and 2), it was considered unnecessary to emphasize this aspect and, consequently, the test series was designed to include three releases into total effluent collectors and only one release into the atmosphere. The latter was over an instrumented network extending to 200 meters and was for the purpose of obtaining particle-size and solubility data. Air-filter samplers were installed on the network to obtain data that could be compared with the data obtained from the two previous test series.

2.1 Test Site

The release test site used in this series had been constructed at the NRTS in 1958 and was largely intact, needing only a minor amount of new construction and rehabilitation to be suitable for the tests. It is known at the NRTS as Test Grid No. 3 (Fig. 1) and is located about one mile north of the Chemical Processing Plant. In general, the site is level and the ground covered with a generous growth of sagebrush. The sampling network is 60 degrees wide and has a centerline that coincides with the most probable wind direction (N55E) during the test periods.

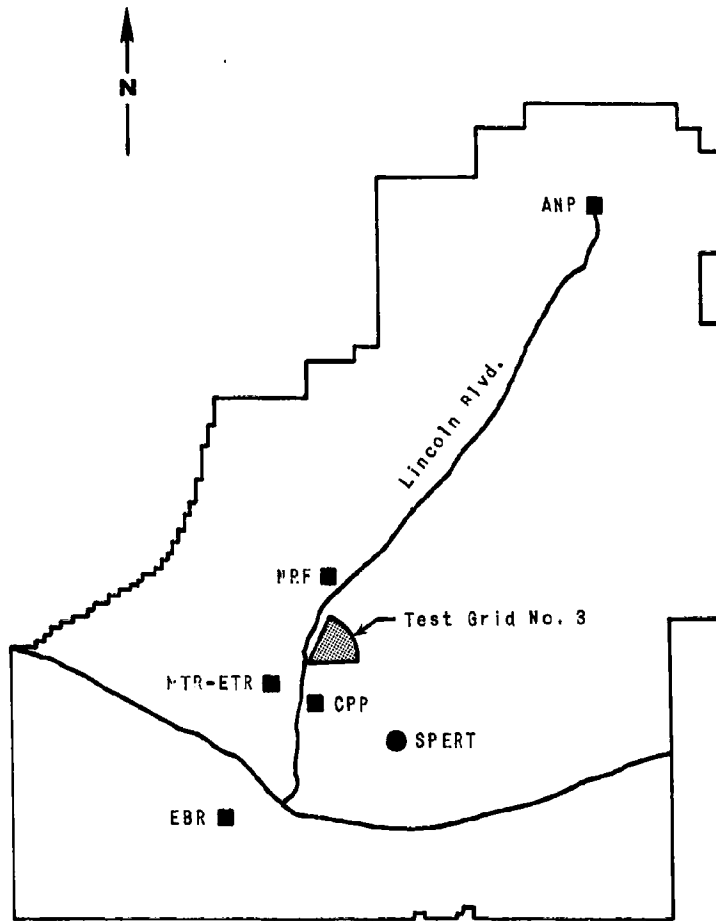

Figure 1. Site Location

2.2 Source of Fission Products

2.2.1 Fuel Elements

Segments of freshly irradiated UO_2 -BeO ceramic unclad fuel elements (Fig. 2) of the PLUTO-type were used in this series of tests. The samples contained approximately 8 weight percent UO_2 of 92 percent U-235 enrichment. The hexagonal fuel samples were 0.300 inch across flats by 4.00 inches long with a 0.200-inch diameter cooling channel. The fuel element specimens were irradiated for a period of one cycle in the MTR reactor to build up the necessary inventory of radioactive fission products. The radioisotopes of interest were those currently deemed to be most biologically hazardous, namely, I-131, Cs-137, Ru-103, Zr-95, Sr-89, Sr-90, Ce-141, Ce-144, and Ba-140.

2.2.2 Induction Furnace

The fuel-element segments were melted in one of three induction furnaces (Fig. 3). Each furnace was constructed of concentric shells - one 26 inches in diameter and the other 12 inches in diameter - welded to a common steel base plate. The bottom six inches of the inner shell and the annulus between the shells were filled with lead. The induction coil was embedded in Kaocast, a castible ceramic insulator, and positioned inside the inner steel shell. This inner shell extended 1-1/2 inches above the outer shell to provide a step to secure the lid to the furnace and to prevent water from saturating the Kaocast during decontamination.

Graphite susceptors were used as working pieces for the induction coil in the furnace, and 1/8-inch-thick tantalum crucibles

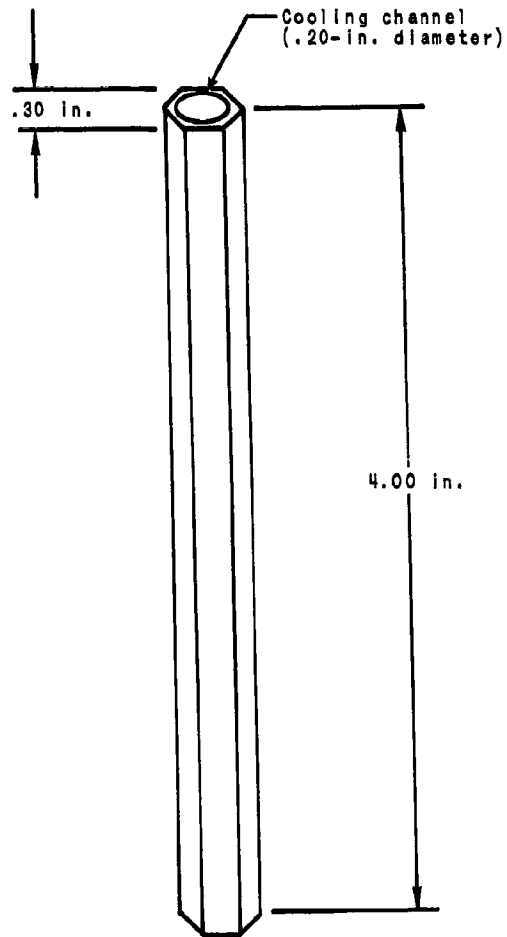

Figure 2. UO_2 -BeO Ceramic Fuel Element

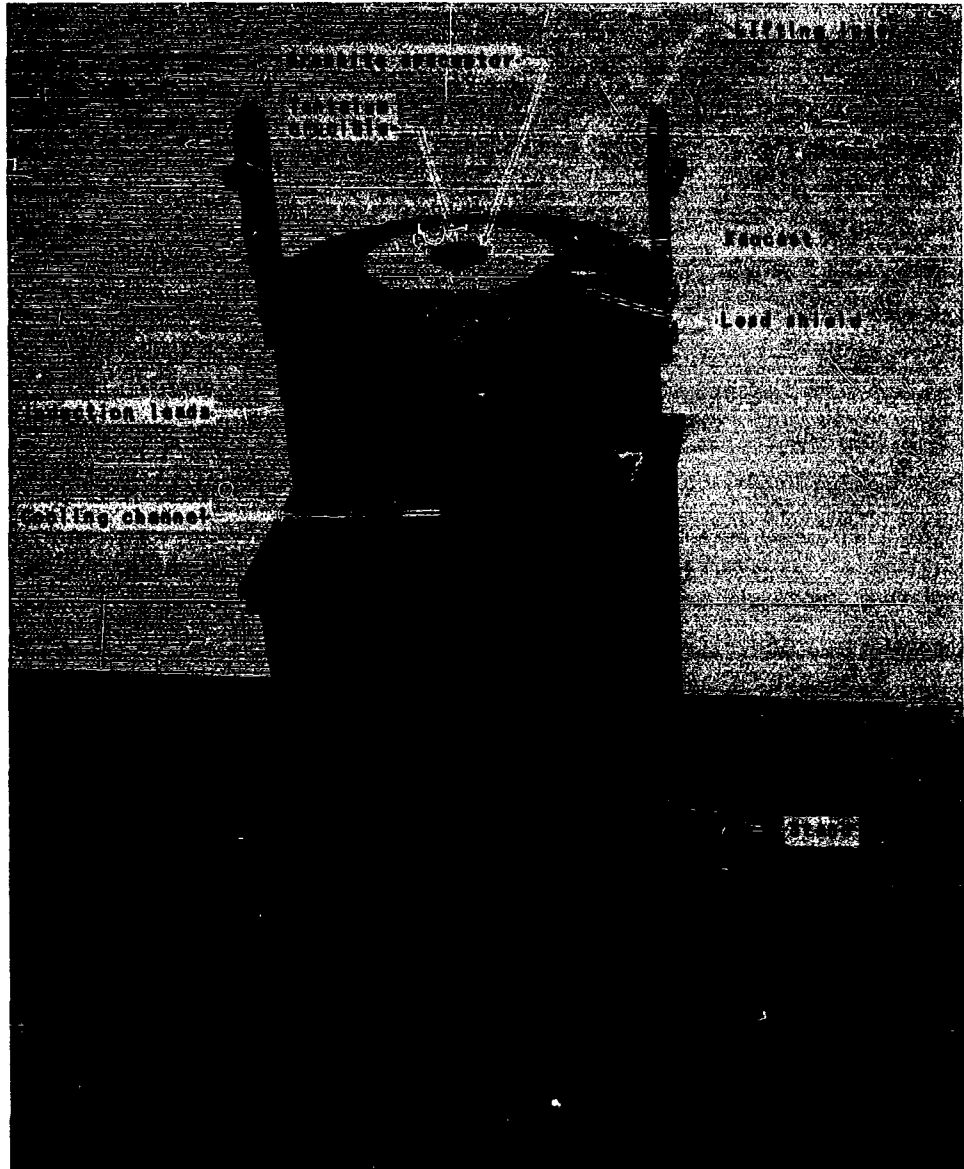

Figure 3. Induction Furnace

having a 1-inch O.D. were used in the graphite susceptors to contain the melt.

To ensure the removal of fission products from the crucible and to add oxygen during the run, a 3/16-inch stainless-steel tube was positioned directly above the mount of the crucible. Air was furnished by a Gast positive-displacement vane pump at approximately 0.1 cfm. One-tenth cfm was chosen because it was adequate to oxidize the melt and yet not erode the tantalum.

Radiation pyrometers were used to measure the temperature of melts during preliminary tests; however, the results of these measurements were erratic. Attempts were made to calibrate a radiation pyrometer aimed at the top edge of the graphite susceptor with a second pyrometer aimed directly into the hole in the susceptor and the crucible. The second pyrometer gave accurate readings of the temperature within the crucible, but could not be used during a "hot" run. The first pyrometer was influenced by wind conditions and ash deposits on the graphite and, therefore, gave erratic readings.

To overcome the temperature-measurement problem, the temperature of the melt, as read by the second pyrometer, was monitored as a function of power input. Approximately 50 kw produced a temperature of 2500°C, which was within the range specified for the tests. All runs with radioactive fuel were made at this power input to the furnace. A typical time-temperature profile and power profile are shown in Figure 4.

2.3 Sampling Network

During the open release, sampling of the radioactive effluent was accomplished by a network of air samplers positioned downwind

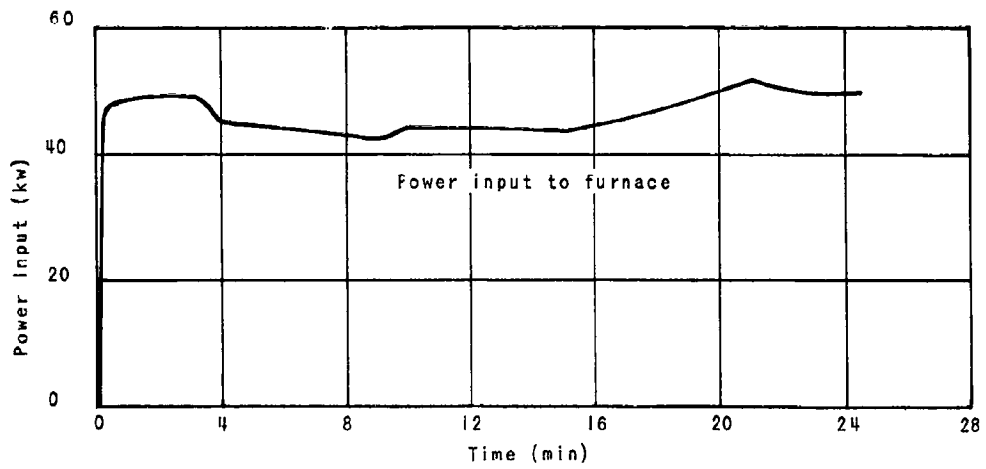
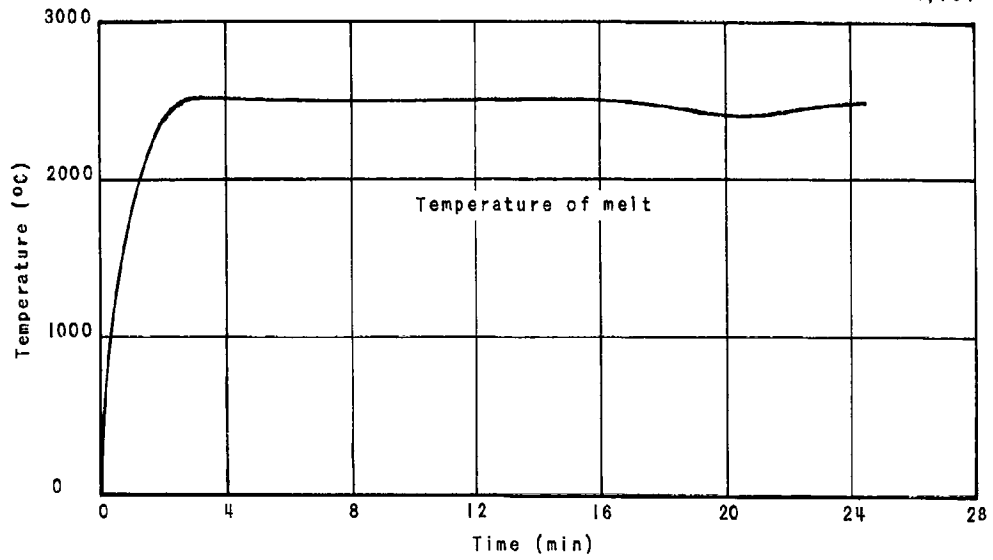

Figure 4. Typical Melt-Temperature and Furnace-Power Profiles

from the release point (Fig. 5). The sampling network consisted of three arcs at 50, 100, and 200 meters from the furnace, with sampling stations spaced at regular intervals across the 60-degree arcs. In addition to the main arcs, samplers were placed on a 6-meter arc to monitor the closed releases for possible accidental release of fission products. There were also some vertical arrays of sticky paper located 45 meters from the release point to obtain vertical-deposition data. Power for the arcs was obtained from the NRTS distribution system.

2.3.1 Radioactivity-Dispersal Measurements

High- and low-volume samplers mounted 1.2 meters above the ground on steel fence posts were used for dispersal measurements (Fig. 6). Staplex high-volume samplers equipped with a filter chain consisting of a 4-inch-diameter Gelman Type E filter backed by an activated carbon cannister (MSA No. 46727) were used on the 200-meter arc. The Staplex unit and filter chain has a mean flow rate of about 13 cfm. The collection efficiency is 99.98% for a 0.3-micron-diameter particles and 100% for gaseous iodine.

Low-volume samplers were the primary sampling units used on the 100-meter arc. These units had a filter chain consisting of a Gelman open-head filter that utilized a 2-inch-diameter Gelman AM-5 filter followed by an activated carbon cartridge of GD/FW design. The Eglin pumping units (built by the Vitro Corporation of America but referred to locally as Eglin because they were obtained from Eglin AFB) supplied an average flow rate of 1.5 cfm through the filter chain. The AM-5 filter has a collection efficiency of 99% for 0.1-micron-diameter particles. For backup

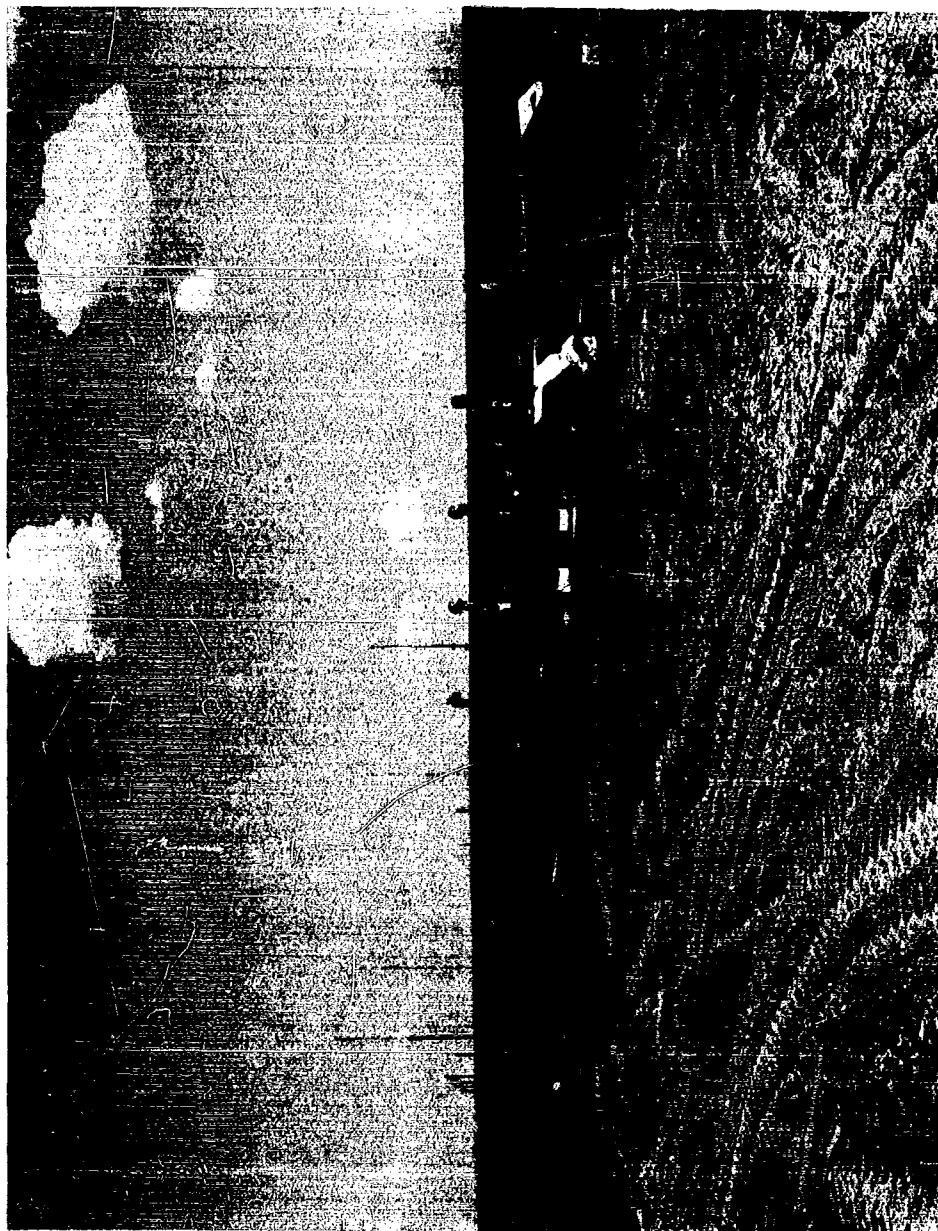

Figure 5. Sampling Network

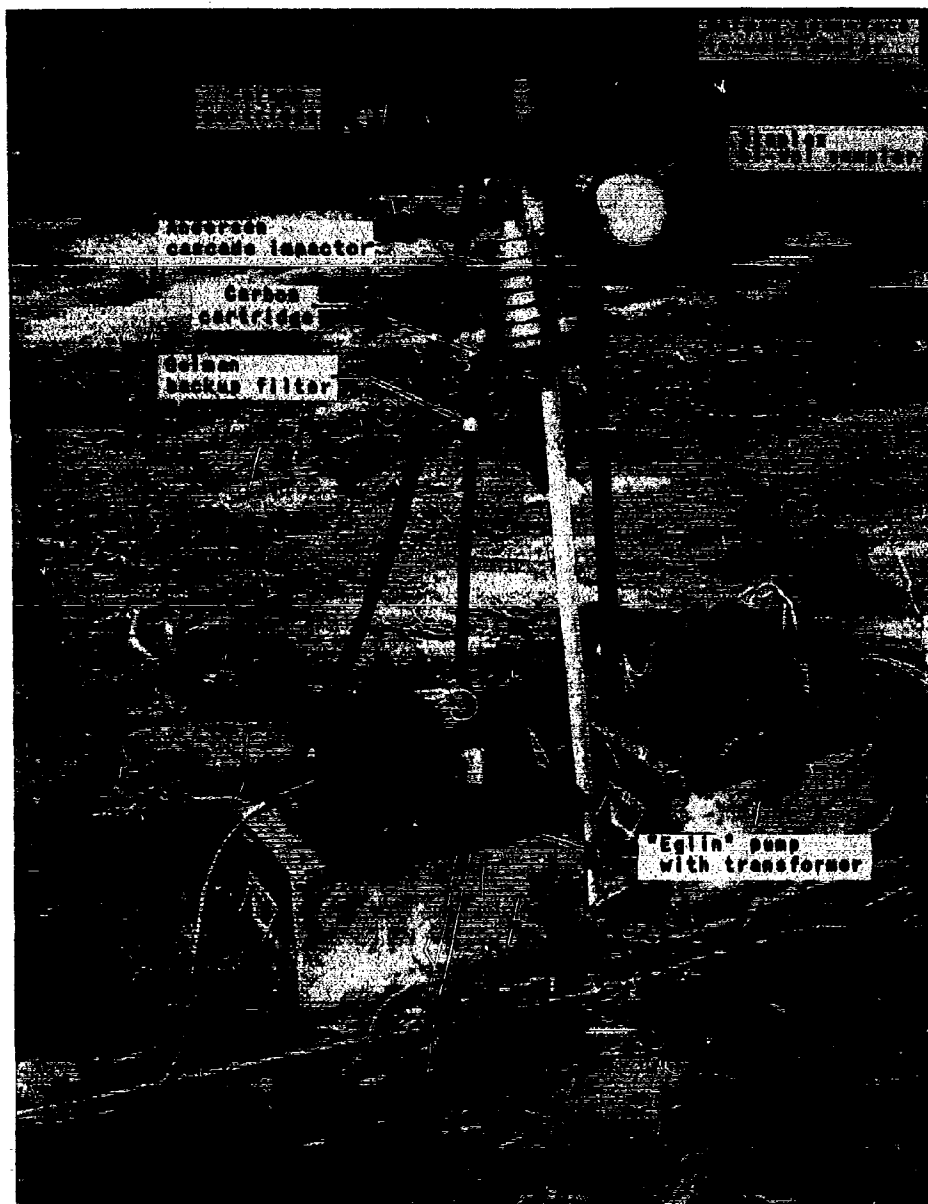

Figure 6. Typical Sampling Equipment

purposes, in case of low-activity release, Staplex samplers previously described were used at every other low-volume sampler station.

2.3.2 Radioactivity-Deposition Measurements

Deposition measurements were obtained with standard adhesive-coated cellulose acetate "sticky" paper measuring 13 inches square and having a 0.0015-inch thickness. A piece of standard 1/2-inch mesh hardware cloth of the same size as the sheet was pressed against the sticky side of the paper to hold the paper in position, face up, in the network. The gummed paper was positioned at ground level at selected sampling stations. Vertical-deposition data were obtained from some of the sticky paper wrapped around cylindrical paper cartons and suspended in vertical arrays from masts 45 meters downwind from the furnace (Fig. 7).

2.3.3 Solubility and Particle-Size Determinations

During the open release, samples were collected to determine relative solubilities of the various isotopes. Each collector consisted of three Gelman open filter heads connected in parallel to an Eglin pumping unit (Fig. 8). These collectors were used at various positions throughout the network.

Information on the radionuclides associated with particles in the fuel effluent was obtained from Andersen samplers with backup carbon cartridges and molecular-membrane filters (Fig. 6). Thirteen of these samplers were located on the 50-meter arc, six on the 100-meter arc, and three on the 200-meter arc.

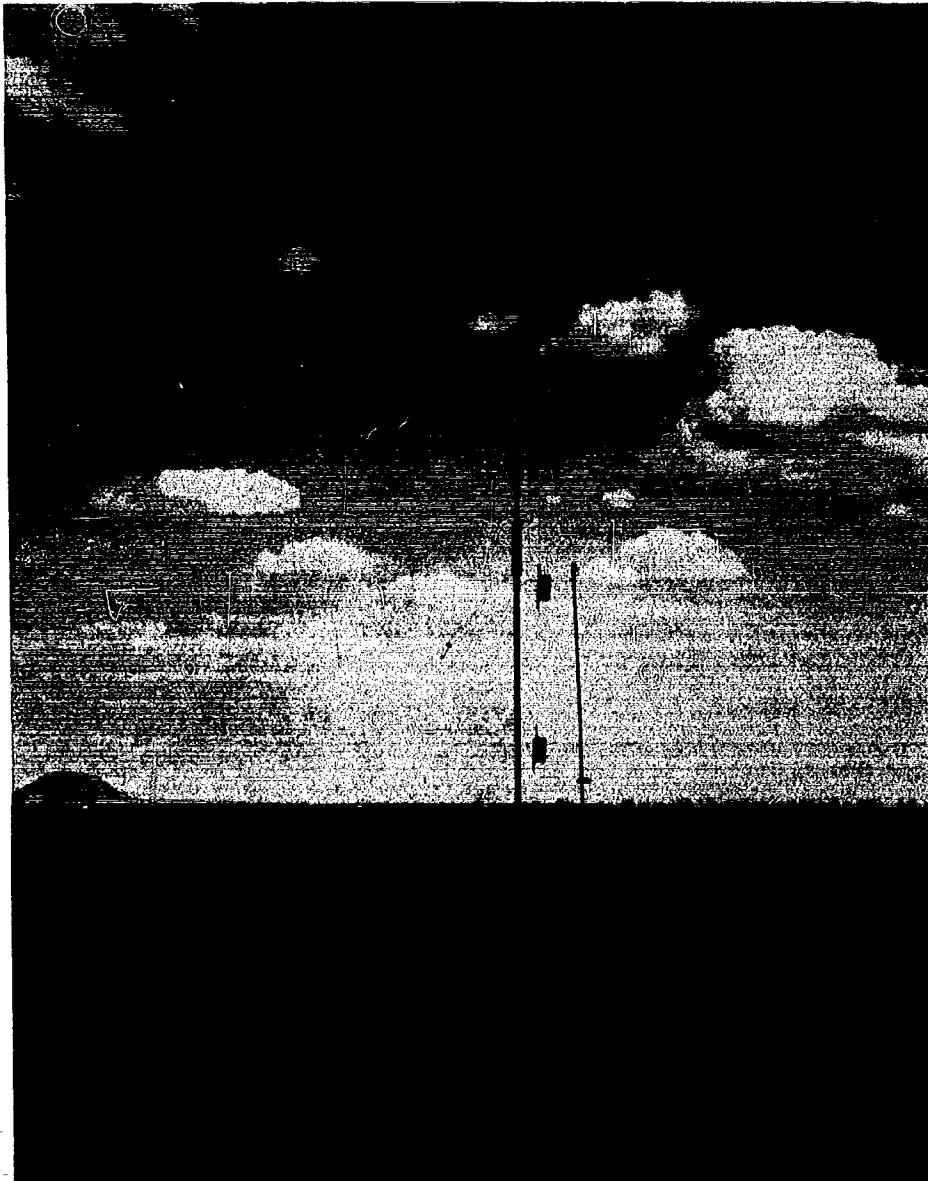

Figure 7. Vertical Sticky-Paper Sampling Station

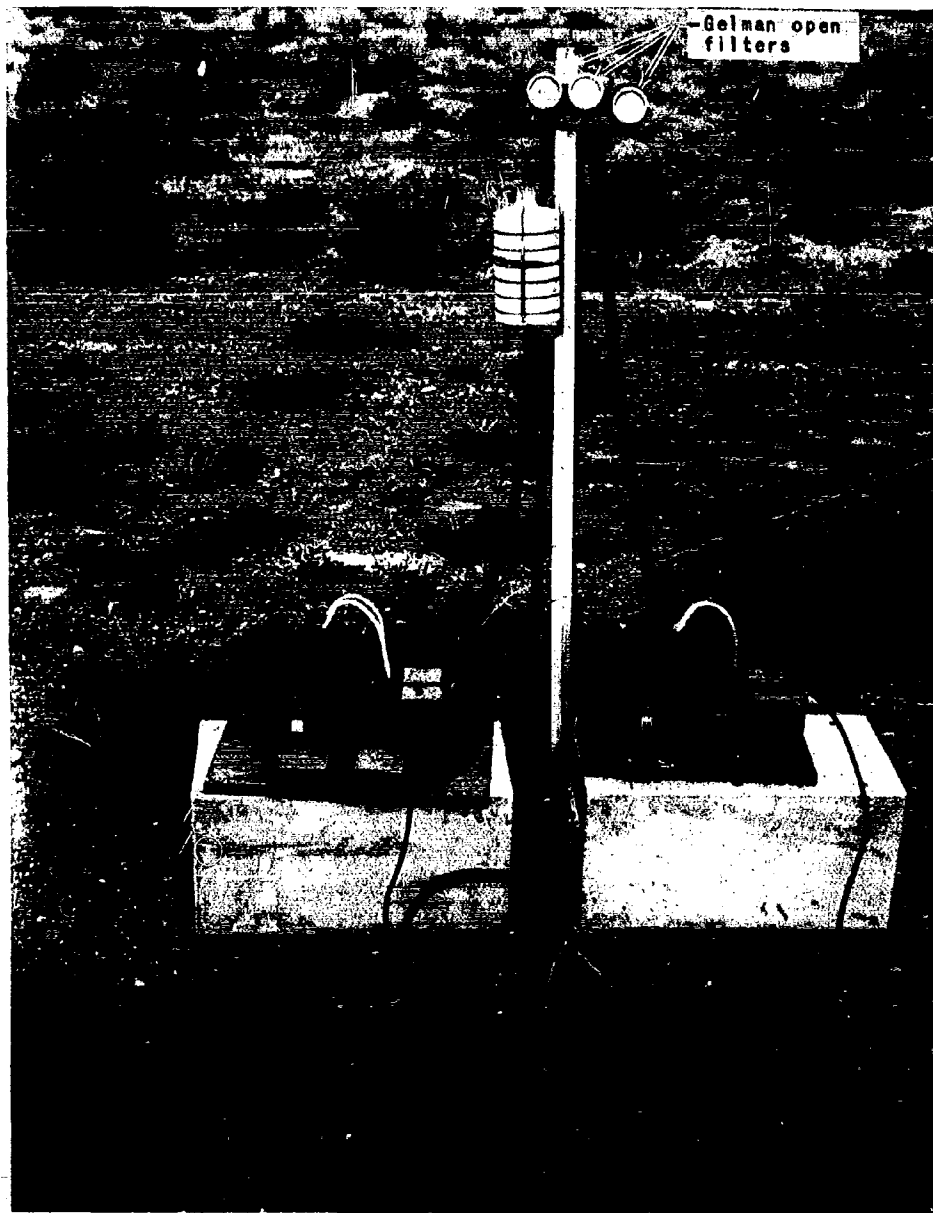

Figure B. Solubility-Sample Filters

2.4 Total Effluent Collector

The total effluent collector consisted of a shielded, cooled shell and a filter assembly through which effluent was drawn by an external vacuum pump (Fig. 9). To prepare the collector for a run, the base was disconnected by removing the bolts in the flanges of the base spool assembly. The collector was then lifted and the telescoping sleeve extended to form a cylinder through which the effluent could flow to reach the filters. Finally, the sleeve was lowered into the collector support (Fig. 10) so that both the collector and the lower end of the sleeve were held in position above the furnace.

During operation, air was drawn through an annular ring between the furnace and the bottom of the collector support where it mixed with the effluent and then passed through the cone in the bottom of the telescoping sleeve. This cone acted as a trap to catch any heavy particles falling out of the air stream and, subsequently, back onto the furnace.

The glass-fiber and steel-wool filter trapped the larger particles, while the two glass-fiber filters trapped the remaining particles in the effluent. Little iodine and practically none of the rare-gas products were trapped in the collector; therefore, other means had to be provided to trap these isotopes. No attempt was made to trap the rare-gas isotopes in this test series, but iodine was collected by a trap containing an MSA Type 46727 activated carbon cannister.

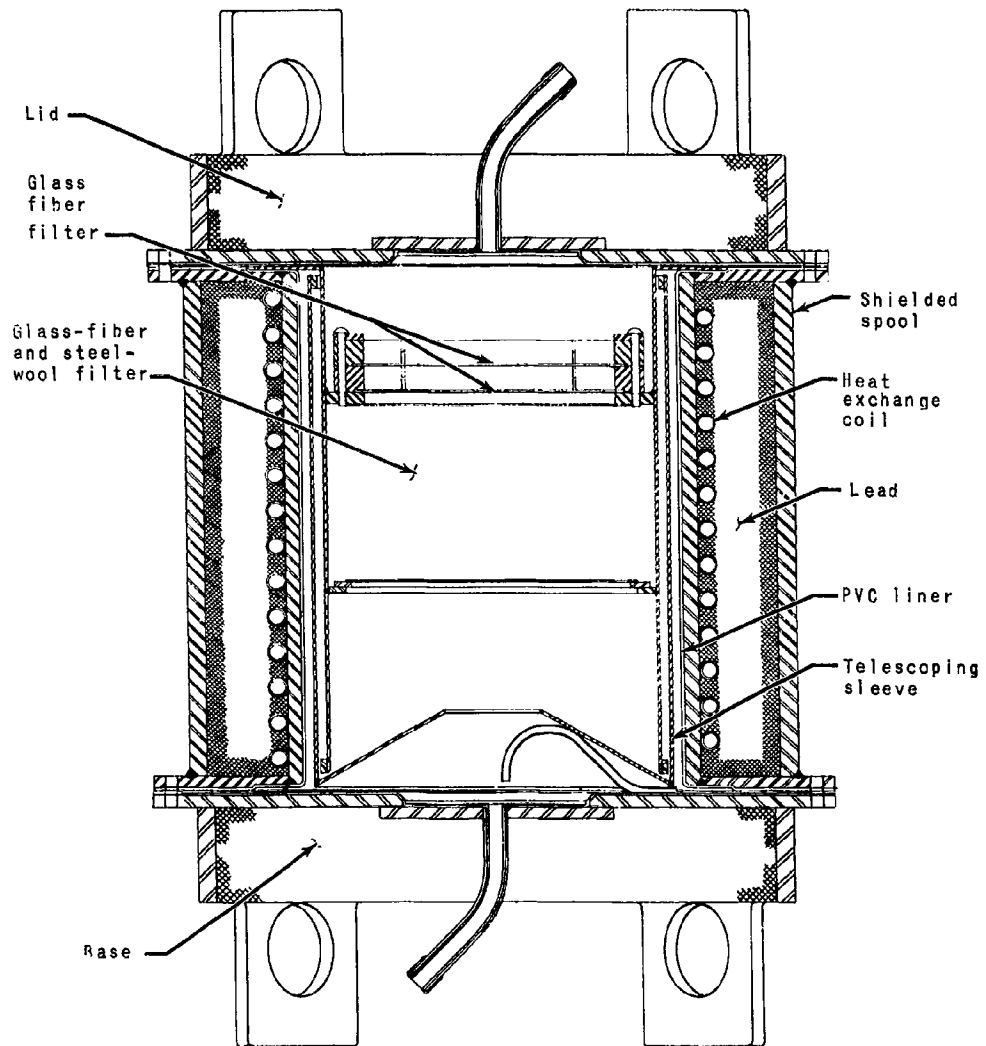

Figure 9. Total-Effluent Collector: Analysis Configuration

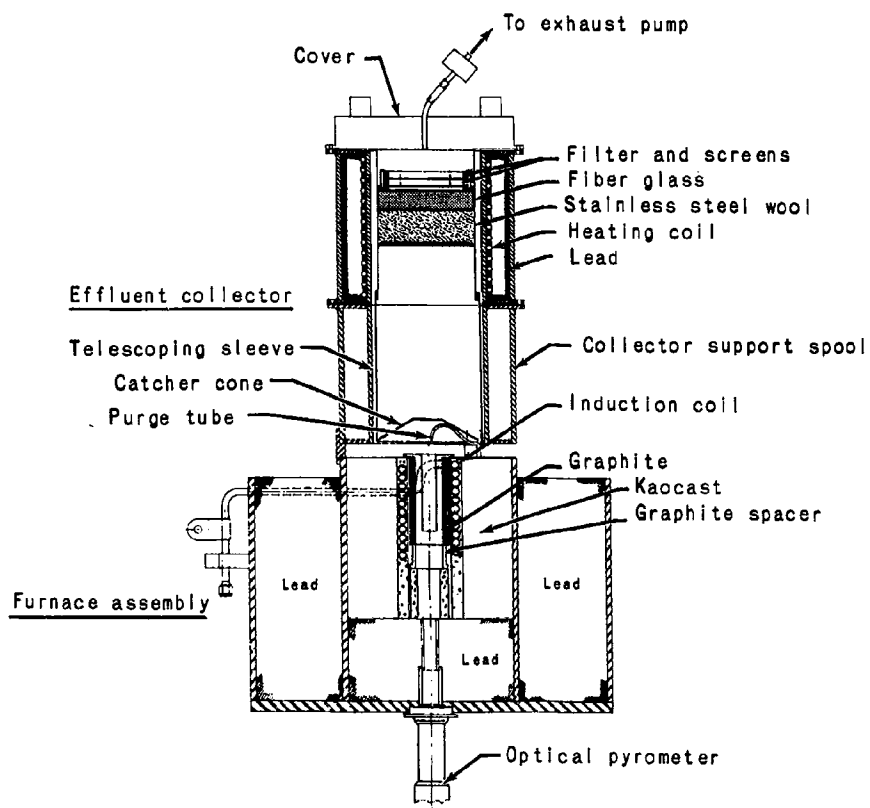

Figure 10. Total-Effluent Collector: Furnace Configuration

After a run, the collector was carefully lifted off the furnace and lowered back onto its base where the sleeve was pushed back up into the spool assembly. The bolts were replaced in the mating flanges and the collector sent to be analyzed.

The collector assembly was designed to act as a container for the dissolution of the material in the filter assembly and, for this reason, the inside surfaces of the spool, lid, and base were coated with a polyvinal-chloride material. The mating surfaces between the lid and base were machined and coated with polyvinal-chloride to provide a liquid-tight seal.

III. ANALYTICAL TECHNIQUES

Radiochemical analyses were performed on postmelt residues, total-effluent collectors, and backup activated charcoal traps to establish fission-product release fractions during each of the tests. Irradiated but unmelted fuel samples were analyzed radiochemically to establish initial fission-product inventories. Gross-gamma surveys were made of fuel segments before and after each melt to determine gross-gamma release fractions.

Network filter samples and gummed papers from the open release were analyzed by gamma spectral techniques to determine aerial dispersal, vertical distribution, and ground deposition patterns for the radioisotopes of concern in this study. Additional filter samples from this release were processed to investigate relative solubilities of the various isotopes in solvents simulating lung and stomach fluids.

Cascade impactor samples were analyzed by gamma spectrographic techniques to determine distributions of the various isotopes as a function of effluent particle size.

3.1 Radiochemical Analyses

The Atomic Energy Division of Phillips Petroleum Company, as a subcontractor to General Dynamics/Fort Worth, was to perform the following radiochemical analyses:

- Analysis of two representative unirradiated fuel samples
- Analysis of two representative irradiated fuel samples
- Analysis of four postmelt residues in tantalum crucibles

- Analysis of three total-effluent collectors
- Analysis of three activated charcoal traps

3.1.1 Dissolution Methods

All unmelted fuel pins were dissolved in 10 M H_2SO_4 . Sixty hours reflux was required to dissolve the unirradiated pin (cold premelt), whereas the irradiated pins (hot premelts) went into solution after 12 hours of refluxing.

The unirradiated furnace residue (cold postmelt) was refluxed three different times with 10 M H_2SO_4 for periods of 24, 72, and 108 hours, respectively. After the first period, 10 mg of uranium were found to be dissolved in the solution; after the second, another 10 mg; and after the third, 6-1/2 mg. These dissolutions were combined and a portion of them fused with anhydrous KF, then dissolved in concentrated H_2SO_4 , and reheated to fusion temperature. This dissolved most of the sample, leaving only a light-grey residue. In spite of the apparent success of this approach on a small sample, it was not followed up because of the large amount of material involved (including Ta, Be, and U), the consequent expense of a development program to prove out the method, and the requirement for additional remote-handling facilities.

Various methods were tried on the irradiated furnace residues (postmelt residues). These included refluxing in 10 M H_2SO_4 , refluxing in concentrated HNO_3 -0.5 M HF, and refluxing in a 50-50 mixture of 48% HF - 0.1 M $K_2Cr_2O_7$. The residue for Release 2 (Pin 36) was dissolved in 10 M H_2SO_4 . No method tried dissolved the other three residues. KF fusion could not be used because of

inadequate facilities and uncertainty as to its applicability in the present case due to the high concentration of tantalum.

The material contained in the three total-effluent collectors (TEC's) was removed by aqua regia in solutions of from 30 to 50 liters per collector. The resultant liquids contained approximately 15%-by-volume solids. Due to the large amount of insoluble material in these solutions, effort was concentrated on the TEC's from Releases 1 and 3 while discontinuing work on the TEC from Release 2. The following steps were taken with each of the remaining solutions:

1. A 100-ml aliquot was poured into a volumetric flask after shaking the sample to suspend the solids.
2. The aliquot was evaporated to near dryness in a beaker, then about 30 ml of aqua regia added and warmed to dissolve the solids.
3. The solution was decanted and the remaining solids treated with aqua regia.
4. Step 3 was repeated and the sample diluted to 100 ml in the case of TEC No. 1 and 200 ml in the case of No. 3.

3.1.2 Analyses

Where solution was effected, total and isotopic uranium was determined by mass assay. With the exception of Sr-89 and -90, other nuclides were determined by gamma spectral analysis using nullification techniques (Ref. 3). Strontium-89 and -90 were separated from solution and counted separately. Gross counts were made, after which the Sr-90 betas were attenuated out and the Sr-89 betas counted. Sr-90 was determined by the difference.

The carbon traps were scanned as received from the field without further treatment.

3.2 Gross-Gamma Measurements

The fuel specimens and residues were too radioactive to measure when removed from the shielding of the furnace; therefore, the lid of the furnace was removed and the instruments were positioned in the beam of gamma rays projected upward from the specimen in the furnace crucible.

Gamma-flux measurements were obtained from each fuel specimen prior to a release and immediately after the release. As many as three sets of premelt gamma measurements were taken on the same specimen on different days while awaiting favorable meteorological conditions for a release.

To obtain these measurements, a 16-ft aluminum pipe was positioned above the furnace. Wire racks were attached to the pipe at 16, 12, 8, 4, and 2 feet from the center of the fuel-element pin. Ion chambers were then attached to the wire. Personnel pocket dosimeters (0 to 200 mr) were used at the 16-, 12-, and 8-ft positions and portable, high-range dose-rate meters (Cutie-Pies) were used at the 8-, 4-, and 2-ft positions. The pocket dosimeters were exposed for periods of between 5 and 30 minutes.

Measurements taken at the 8-, 4-, and 2-ft positions with the dose-rate meter should not be expected to be as accurate as those determined with the pocket dosimeters at the 16-, 12-, and 8-ft positions. The dose-rate meters at the lower positions measured many of the beta particles and low-energy backscatter gamma rays that could be absorbed or degraded in energy before reaching the pocket dosimeters. Since the density of the pocket dosimeter

wall is 308 mg/cm², only the higher-energy beta particles will penetrate and be recorded.

3.3 Gamma-Ray Spectroscopy

Field samples were packaged according to the following schedule to maintain sample integrity, prevent cross contamination, and facilitate labeling.

<u>Type of Sample</u>	<u>Packaging</u>
Gelman filter 2-in. diameter	2 x 2 x 0.5-in. cardboard box
4-in. diameter	Folded in 1/4's, active side in; 2 x 2 x 0.5-in. box
Sticky papers 13 x 13-in., and 6.5 x 6.5 in.	Folded with active sides in to fit 2 x 2 x 0.5-in. box
Carbon cartridges 3-1/2-in. diameter, MSA	Wrapped with Saran Wrap
1-1/2-in. long x 0.75-in. diameter, GD/FW	Capped polyethylene vials, front face at bottom of vial
Andersen sampler plates	Active face down in capped plastic petri dish
Hydra head solutions	10-cc aliquot in 20-cc capped poly- ethylene vial

3.3.1 Spectral Techniques

A minimum of 8-inch-thick lead shielding providing an 8 x 8 x 8-inch cavity in the vicinity of the crystal was used. The packaged samples were placed directly upon a standard Harshaw mounted 3 x 3-inch NaI(Tl) crystal. This technique had proved to be practical during earlier work and obviated redetermination of detection efficiencies for each of the isotopes encountered.

Spectra were accumulated on an RCL 256-channel analyzer and recorded on strip charts. The strip charts are sufficiently accurate to allow quantitative analysis of the constituent isotopes. Figure 11 is typical of the spectra encountered.

3.3.2 Spectral Reduction

The reduction program considers twenty-two isotopes and ignores spectral contributions of others. This computer code employs a set of twenty-two simultaneous equations based on the differential pulse-height spectrum of each isotope. The solution of these equations yields the contribution of each isotope to the total spectrum. Application of appropriate detection-efficiency values, decay corrections, and sampler flow rates yields the quantitative analysis of each isotope in units of curie-seconds per cubic meter at release time. The raw data were obtained manually from strip-chart recordings and all subsequent steps in the reduction program were performed through the use of an IBM-7090 digital computer.

3.4 Solubility Determinations

The Gelman AM-5 filters from the triple-head Gelman units scattered on the arcs were surveyed and the three sets showing the most uniform activity were selected for solubility determinations. One filter was set aside as a control while the other two were placed in Millipore filter holders (XX1004700). To one holder was added 20 cc of distilled water (simulating lung fluid) and to the other, 0.5 volume percent HCl (simulating stomach fluid). The filters were then allowed to stand in the solution for 20 minutes at 70°F, after which the solutions were pulled through the filters and 10-ml aliquots withdrawn and stored in polyethylene vials for gamma spectral analysis.

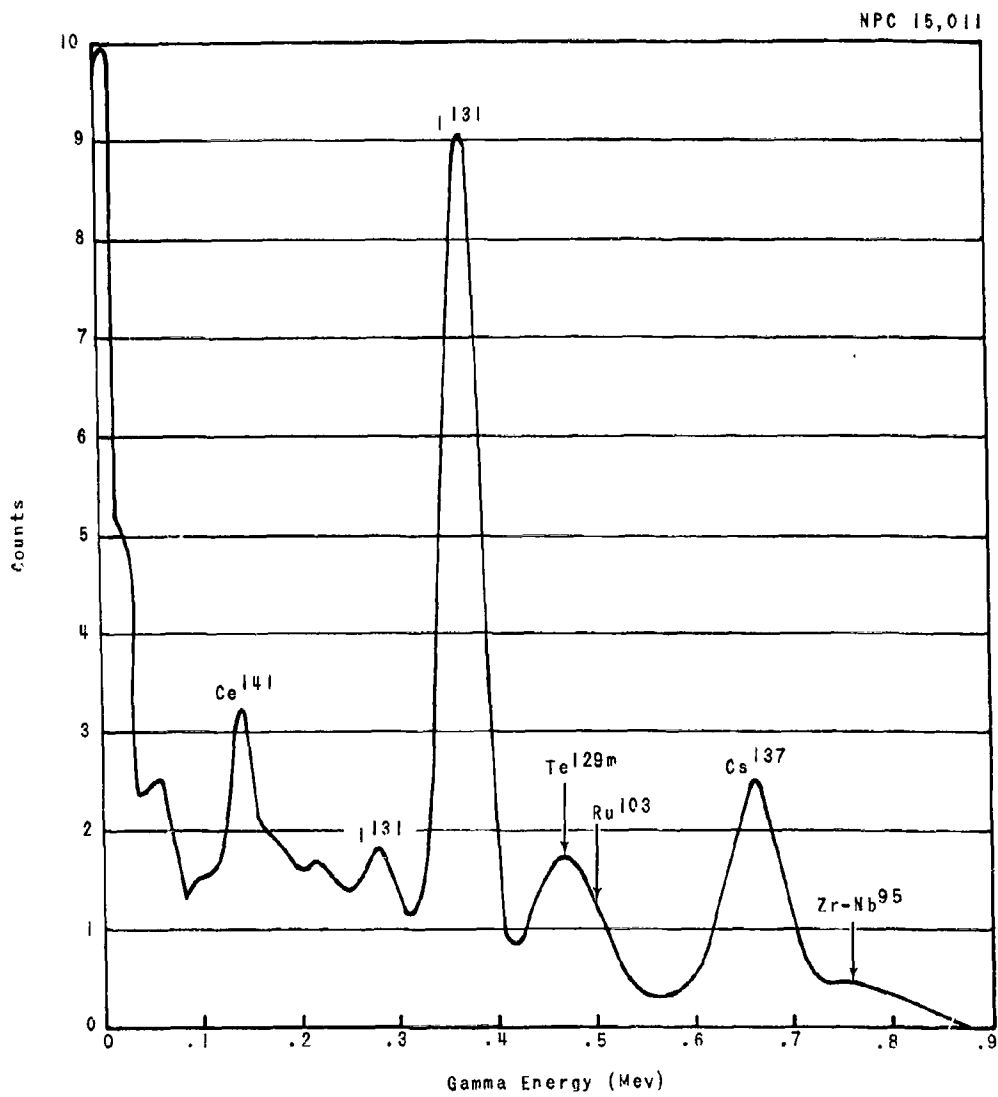

Figure 11. Typical Gamma Spectrum

3.5 Isotopic-Release Percents from Open-Release Data

The difficulties encountered in the radiochemical analyses led to the consideration of other possible methods of arriving at release percents. The equation given below was used to determine the release percents at each station where air sampling data were obtained. The values at all the stations for each nuclide were then averaged to give the release percent of a specific nuclide.

The release percent of a particular nuclide was obtained from the equation

$$R_x = \left(\frac{X_x}{X_s} \right) \left(\frac{R_s I_s}{I_x} \right) ,$$

where

R_x = release percent of nuclide desired
 X_x = nuclide activity from sampling station
 R_s = known release percent of one isotope
 I_s = inventory of known isotope
 I_x = inventory of nuclide of interest
 X_s = known isotope activity from sampling station

The validity of such a method depends upon the following conditions:

- Various isotopes diffusing over the network in a similar manner.
- Various isotopes being released at approximately the same time.

The release percent being known for one of the isotopes.

IV. RESULTS AND DISCUSSION

4.1 Synopsis of Field Test Operations

The first test employing a total-effluent collector was not an unqualified success. A fire occurred around the outside of the furnace during the last few minutes of the 20-minute holding period, so that the holding period was reduced to about 16 minutes. The reduced period was not thought to be serious because the melting of a sample and release of most of the effluent are believed to occur in the first 5-10 minutes of full furnace power.

Prior to the second closed release, additional precautions were taken to see that no fires or other accidents might occur; and until the completion of the test, it seemed that a perfect release had been made. Monitoring of the iodine trap on the discharge from the TEC after the release and cool-off period indicated that the activity collected was much lower than expected. The TEC was opened, and it was found that the exhaust opening was plugged. Since the exhaust had been blocked during an unknown fraction of the release period, the experiment was subject to question.

The third closed release was satisfactory, even though the planned 20-min. holding period was shortened to 19 minutes by the automatic tripping of the furnace power resulting from an electrical transient. Furnace power could not be recovered in time to be useful; therefore, the test was terminated by the accidental shutdown.

During the fourth release, in which the effluent was allowed to escape into the atmosphere, the wind varied considerably in both velocity and direction. As a result the effluent passed over almost all portions of the sampling network and almost all of the samples indicated some activity above normal background. Samples collected from the network after the release were processed to a uniform geometry for gamma-ray spectrographic analysis and then given a preliminary check for total activity. The samples were then shipped to a GD/FW gamma-ray spectrographic facility where spectrograms were run.

The induction furnaces containing the crucibles with melt residues were sent to the MTR Hot Cell Facility where each tantalum crucible was removed from its graphite susceptor, placed in a plastic bag, and then crushed in a press. The bag and contents were then delivered in a shielded container to the Chemical Processing Plant for radiochemical analysis. The TEC's and iodine traps from the three closed releases were sent directly to the Chemical Processing Plant from the test site.

4.2 Fuel Irradiation

Lawrence Radiation Laboratory furnished eight numbered UO_2 -BeO fuel samples from the same manufacturing batch in an attempt to provide uniformity. The reported uranium loadings and the disposition of the samples are shown in Table 1.

TABLE 1
Fuel Element Test Data

Sample No.	U wt %	Irradiated	Melted	Melt No.	Release Type	Remarks
19	8.08	No	No	-	--	Premelt cold
42	8.09	No	Yes	0	Open	Postmelt cold
26	8.02	Yes	Yes	1	Closed	TEC No. 1
36	7.95	Yes	Yes	2	Closed	TEC No. 2
50	8.08	Yes	Yes	3	Closed	TEC No. 3 (broken pin)
46	8.01	Yes	Yes	4	Open	
17	7.95	Yes	No	-	--	Premelt irradiated
38	8.00	Yes	No	-	--	Premelt irradiated

Six fuel elements were encapsulated in aluminum tubes, helium purged, welded shut in a helium atmosphere, and leak-tested prior to irradiation. They were inserted into the MTR and irradiated to an average burnupt of 0.75%. The inventories of fission products were computed from literature values of the nuclear-yeild fractions and half-lives, together with the MTR irradiation history. The computed inventories and the results of radiochemical analyses of the premelt irradiated samples are compared in Table 2.

TABLE 2
Inventory at End of Irradiation

	Half-Life	Calculated Inventory (d/m)	Phillips Pin 17(d/m)	Phillips Pin 38(d/m)
Ce-144	282 d	1.8 (12)*	2.7 (12)	2.4 (12)
Ce-141	33.1 d	1.3 (13)	0.95 (13)	0.85 (13)
Sr-90	27.7 yr	5.1 (10)	41 (10)	38 (10)
Cs-137	33 yr	4.3 (10)	3.5 (10)	3.2 (10)
Sr-89	50.5 d	7.4 (12)	6.5 (12)	6.0 (12)
I-131	8.1 d	1.6 (13)	0.07 (13)	0.12 (13)
Zr-95	65 d	9.4 (12)	5.5 (12)	3.9 (12)
Nb-95	35 d			
Ba-140	12.8 d	5.4 (13)	1.6 (13)	0.95 (13)
La-140	40.2 h			
Ru-103	39.8 d	5.5 (12)	4.9 (12)	4.0 (12)
Ru-106	1 yr			

*1.8 (12) = 1.8×10^{-12}

The agreement between the calculated and the measured inventories is not particularly good. The calculated and measured activities of biologically significant I-131 and Sr-90 differed by approximately an order of magnitude. In an effort to resolve these differences, the radiochemistry procedures and computer program results were reviewed.

It was learned that off-gases were not collected during the dissolution process. It is probable that loss of gaseous

iodine during chemical separation can account for the low measured iodine activity.

In the case of strontium, the following comparison was made. Since Cs-137 and Sr-90 have approximately the same fission yields and half-lives, their inventories should be about the same. From Table 2, it is seen that the Cs-137 calculated and measured activities agree and are approximately the same as the calculated Sr-90 activity. Therefore, it seems that the radiochemically determined Sr-90 activity is in error, and it is assumed that the difference between the calculated and measured inventories for Sr-90 is due to some discrepancy in the radiochemical analysis.

4.3 Release Percents

4.3.1 Radiochemical Analyses

In the original planning of the test series, the release percents for the various radioisotopes were to be derived from radiochemical analysis of control samples of the fuel, the melt residues, and the collected effluents. The combination of very high temperature and oxidizing atmosphere, however, converted the fuel elements into chemical forms that were exceedingly difficult, if not impossible, to get into solution (see Sec. 3.1.1). The release percents presented in Table 3 were obtained from use of Tables 4 and 5. Release fractions for short-lived isotopes should not be assumed to be zero. The TEC's were analyzed approximately one year after release, therefore, the shorter-lived isotopes had decayed and were not detected. Release percents of the total rare earths were not determined because the control and TEC samples were analyzed at different times (approximately one year) and it was not possible

to determine the decay factor for these unknown mixtures of rare-earth isotopes.

4.3.2 Open Release

The release percents given in Table 6 were obtained from the sampler data taken during the one open release. Cs-137, as determined by radiochemical analyses of the TEC's and premelt fuel samples, was chosen as the standard for calculation of the other isotopic release percents.

TABLE 3

Release Percents Based on Phillips Petroleum Co. Data

Material	Release Percent
U	0.39 ± 0.09*
Be	0.030**
I-131	56***
Cs-137	65 ± 6
Ce-144	0.010 ± 0.004
Sr-90	0.0012 ± 0.0006

*Standard deviations do not take into account the variance of the numbers used in determining the inventory and effluent analyses.

**Determined from TEC analysis and calculated beryllium inventory in fuel pin.

***Average value - determined from calculated inventory and two TEC and carbon-trap values.

TABLE 4

Uranium and Beryllium Analysis

Fuel Pin No.	Designation	Vol. of Solution (liters)	Uranium Concentration (g/liter)	Total Uranium (g)	U-234 %	U-235 %	U-236 %	U-238 %	Total Beryllium (g)
19	Cold Premelt	0.5	1.30	0.65	1.09	93.26	0.81	4.84	
42	Cold Postmelt	-	-	-	1.03	93.14	0.76	5.07	
17	Hot Premelt	0.5	1.31	0.66	1.10	91.73	0.96	6.20	
38	Hot Premelt	0.5	1.30	0.65	1.11	91.57	0.96	6.36	
26	Postmelt* Residue 1		9.3x10 ⁻²		0.8	74.6	0.8	23.8	
	Residue 1		1.7x10 ⁻²		0.3	20.5	0.4	78.8	
36	Postmelt Residue 2	1.0	0.63	0.63	1.10	90.28	0.93	7.69	
50	Postmelt Residue 3		1.5x10 ⁻²		1.10	92.5	0.9	5.5	
	Residue 3		2.9x10 ⁻²		1.0	56.3	0.7	42.0	
46	Postmelt* Residue 4		1.7x10 ⁻²		0.9	90.95	0.96	7.2	
	Residue 4								
26	TEC** 1	40		0.0012					0.001
36	TEC 2	50.5	< 5x10 ⁻⁵						
50	TEC 3	28.0		0.0039					0.001

*Two determinations made

**Total Effluent Collector

TABLE 5
Radiochemical Analysis
(Activities in d/m*)

Isotope	Fuel Pin No./Release No.								
	Hot Premelts		Postmelt Residue**	TEC's			Carbon Traps		
	17/0	38/0		26/1	36/2	50/3	26/1	36/2	50/3
Cs-137	3.5(10) [#]	3.2(10)	3.3(12)	2.5(10)	1.8(10)				
Zr-Nb-95	5.5(12)	3.9(12)		NIL	3.4(8)				
Zr-95	9.5(12)	8.5(12)	4.4(12)	9.4(7)	4.2(8)				
Ce-141	2.7(12)	2.4(12)	1.7(11)	1.6(11)					
Ce-144	4.9(12)	4.0(12)		5.4(8)	1.1(7)				
Ru-103-106			4.0(10)	2.1(11)	7.1(11)			1.0(13)	7.8(12)
Ru-106	7.0(11)	1.2(12)		7.7(5)	2.1(6)				
I-131	4.1(11)	3.8(11)		2.3(7)					
Sr-90	6.5(12)	6.0(12)		5.1(7)					
Sr-89	1.6(13)	9.5(12)							
Ba-Ia-140	9.5(12)	8.5(12)							
TRE									

*Activities corrected to 7/5/61, except underlined data.

Activity count on 8/30/61.

**No postmelt residue data for Releases 1, 3, and 4.

Activity count on 7/11/62.

[#]Read 3.5(10) as 3.5 x 10¹⁰.

TABLE 6
 Release Percents Based on Open Release Data
 (Based on 65% release of Cs-137)

Isotope	Release Percent
I-131	45 ± 3
Te-129m	2.1 ± 0.1
Ru-103	0.53 ± 0.09
Ce-141	0.14 ± 0.02
Zr-95	0.11 ± 0.01

4.3.3 Gross-Gamma Determinations

The release percentages shown in Table 7 were obtained directly from the pre- and postmelt gross-gamma measurements. Ionization-chamber readings were then corrected to account for radioactive decay during the time lapse between pre- and post-melt measurements. The data from the Cutie-Pie readings were not complete and showed large variations in some cases. Therefore, they were not processed further.

It will be noted that the release percents for Releases 1 and 3 are 33 and 30 percent, respectively, whereas Release 2 gives 25 percent. Since Release 2 was not a normal release (plugged outlet on TEC, etc.), it is better to neglect the latter figure and average the two former. This procedure gives an average of 31.5 percent for the two closed releases.

TABLE 7
Release Percents Calculated from Gross Gamma Measurements

Distance (ft)	Release 1 (Closed)			Release 2 (Closed)			Release 3 (Closed)			Release 4 (Open)					
	Ion Cham. Ratio	Release %	Cutle Pie Ratio	Ion Cham. Ratio	Release %	Release %	Ion Cham. Ratio	Release %	Cutle Pie Ratio	Release %	Release %	Ion Cham. Ratio	Release %	Cutle Pie Ratio	Release %
16	.61	39		.74	26		.63	37				.57	43		
12	.74	26		.78	22		.65	35				.54	46		
8	.50	50	.52	.58	42	48	.78	22	.50	50	50	.54	46	.63	37
4			.53			47			.82	18	18			.25	75
2			.45			55			.96	4	4			.31	69
Average No Decay		38			30	50		31		24			45		60
Average With Decay		33			25			30					45		

The release percent for the open release, as obtained from the ionization chambers, is 45 percent. There is close agreement between the sets of readings for the three distances and no apparent reason for questioning the results. Therefore, the differences between open and closed releases, as measured by the techniques previously described, appear to be real.

One possible explanation for the difference is that, in the case of the closed releases, some particles may have hit the underneath surface of the plate that fits between the furnace and the TEC and fallen back onto the top of the graphite susceptor or the thermal insulation surrounding it, so that they were measured in the post-melt gross-gamma measurements. This would make the release percent appear lower than it actually was. In the case of the open release, the wind sweeping over the top of the furnace during the release period would have swept the particles away from the top of the furnace and onto the ground within a short distance of the source point.

4.4 Dispersal of Effluent

4.4.1 Activity Release Height

The furnace height of approximately 1.5 meters and measurements of the activity found on gummed paper from two vertical arrays (Sec. 2.3.2) indicate that the centerline of activity was between one and two meters above the ground as the activity entered the sampling network. Data for the six isotopes of concern are shown in Figure 12.

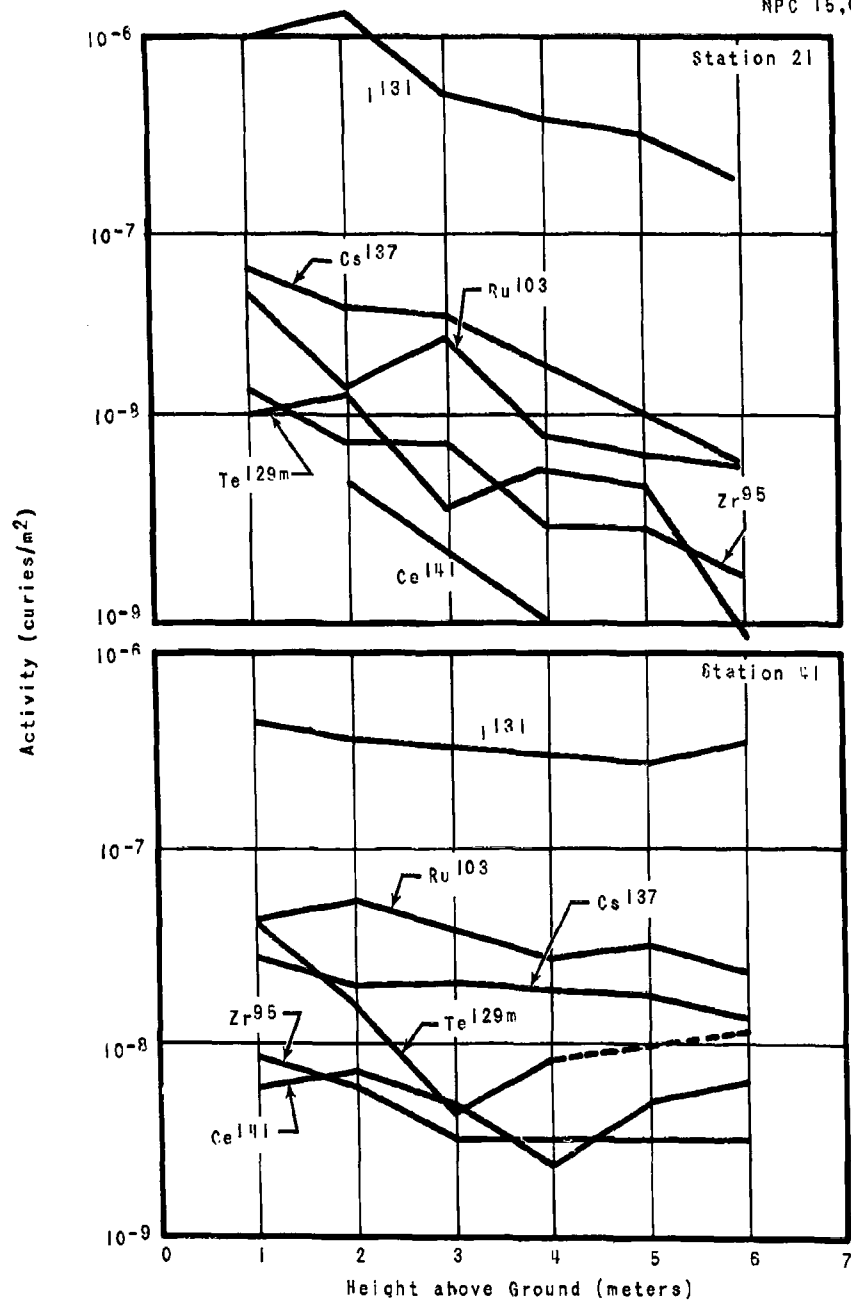

Figure 12. Activity Release Height On 115-Meter Arc

4.4.2 Air Concentration

Air concentration isopleths are shown in Figure 13. The arc data from which these isopleths were derived are from the type of sampler giving the most complete picture for each arc, i.e., the 50-meter arcs are Andersen data, the 100-meter arcs are Gelman-head, Eglin-pump-unit data, and the 200-meter arcs are Staplex data.

4.4.3 Ground Contamination

Ground-contamination isopleths are shown in Figure 14. Data for these isopleths were obtained from pulse-height spectral analyses of gummed-paper placed at ground level at selected arc stations.

4.4.4 Deposition Velocities

Deposition velocities, the ratio between ground radioactivity levels ($\text{curies}/\text{cm}^2$) and integral-air levels ($\text{curie-sec}/\text{cm}^3$), have been determined for six nuclides. Table 8 presents the average deposition velocities on each arc for each type of sampler used, in addition to the overall average for the release. The numbers in parentheses are the number of stations averaged.

4.4.5 Solubility

Attempts to determine the relative solubilities of six isotopes in solutions similar to lung and stomach fluids yielded only general results (Fig. 15). As might be expected, isotopes investigated were more soluble in the acidic stomach solution than in water. However, due to the erratic nature of the data collected, no attempt was made to determine specific solubilities.

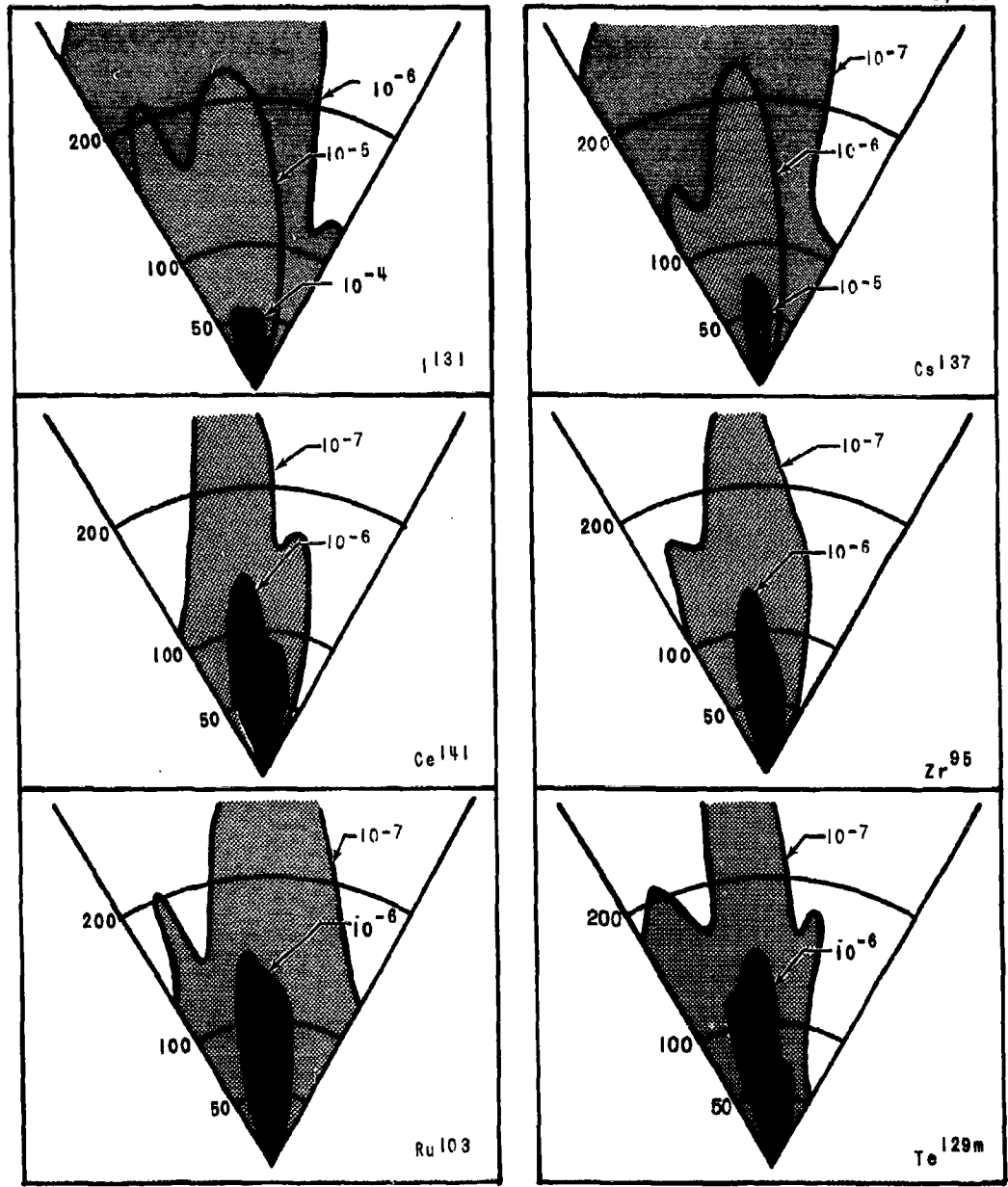

Arc distances in meters

Figure 13. Air Concentration Isopleths (curie-sec/meter³)

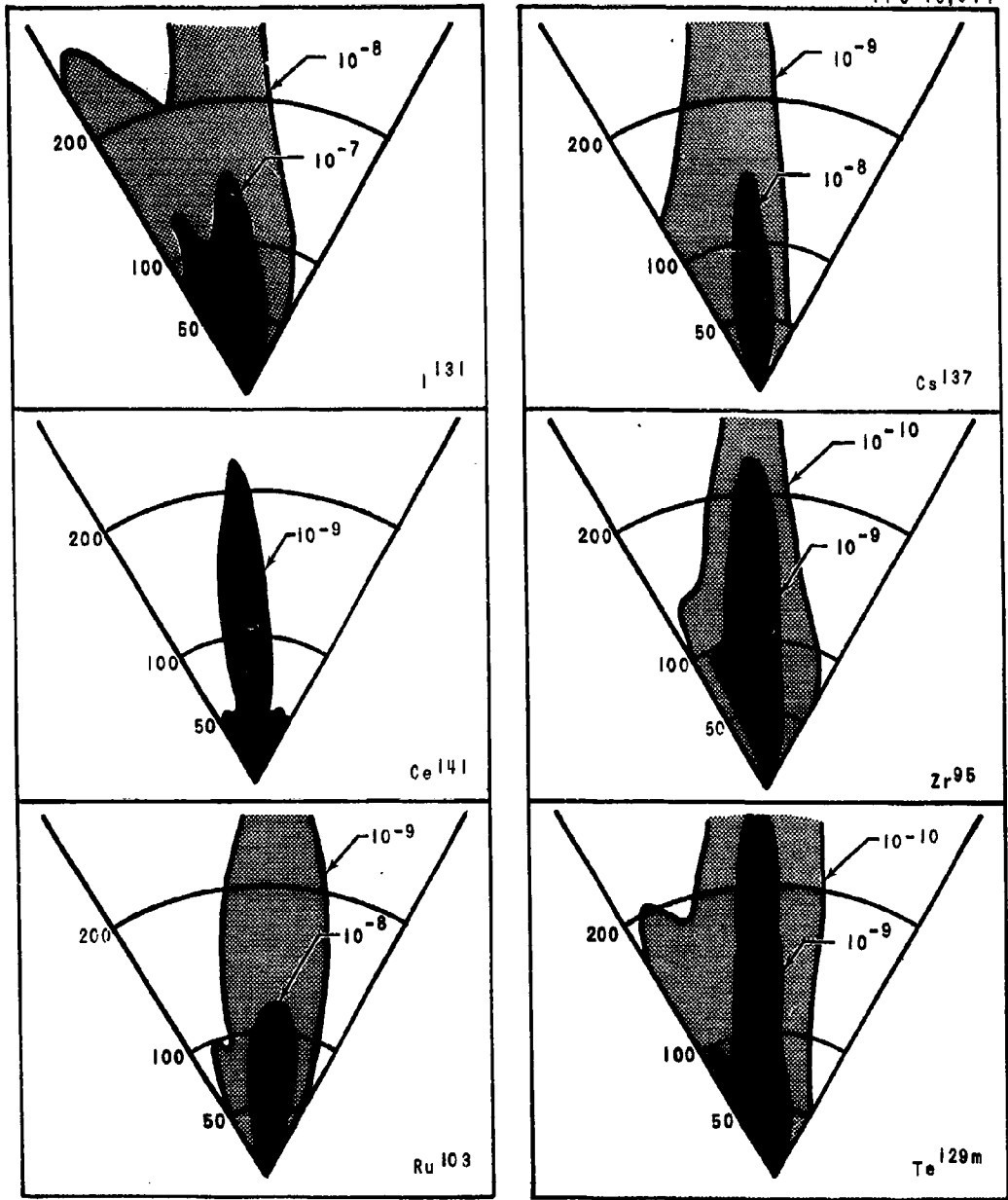

Arc distances in meters

Figure 14. Ground-Contamination Isopleths (curies/meter²)

TABLE 8
Average Deposition Velocities
(cm/sec)

Nuclide	Andersen Samplers			Lo-Vol Samplers 100-Meter Arc	HI-Vol Samplers		Average All Arcs
	50-Meter Arc	100-Meter Arc	200-Meter Arc		100-Meter Arc	200-Meter Arc	
I-131	0.69 ± .09 (13)	0.79 ± .19 (5)	0.55 (1)	0.27 ± .03 (11)	0.41 ± .08 (6)	0.37 ± .05 (6)	0.50 ± .05 (42)
Cs-137	0.10 ± .03 (13)	0.64 ± .36 (5)	1.29 (1)	0.13 ± .02 (10)	0.17 ± .02 (5)	0.35 ± .20 (2)	0.28 ± .06 (36)
Ru-103	0.72 ± .20 (13)	1.08 ± .58 (5)	1.45 (1)	0.48 ± .09 (10)	0.94 ± .31 (5)	0.43 ± .12 (3)	0.73 ± .12 (37)
Zr-95	0.18 ± .04 (12)	0.48 ± .06 (4)	1.22 (1)	0.23 ± .03 (10)	0.35 ± .09 (5)	0.32 ± .07 (2)	0.29 ± .04 (34)
Te-129m	0.24 ± .06 (12)	0.19 ± .13 (4)	2.29 (1)	0.12 ± .02 (9)	0.16 ± .05 (5)	0.51 ± .38 (3)	0.27 ± .07 (34)
Ce-141	0.13 ± .04 (11)	0.17 ± .07 (4)	-	0.16 ± .03 (7)	0.16 ± .02 (3)	-	0.15 ± .02 (25)

() Indicates number of samples

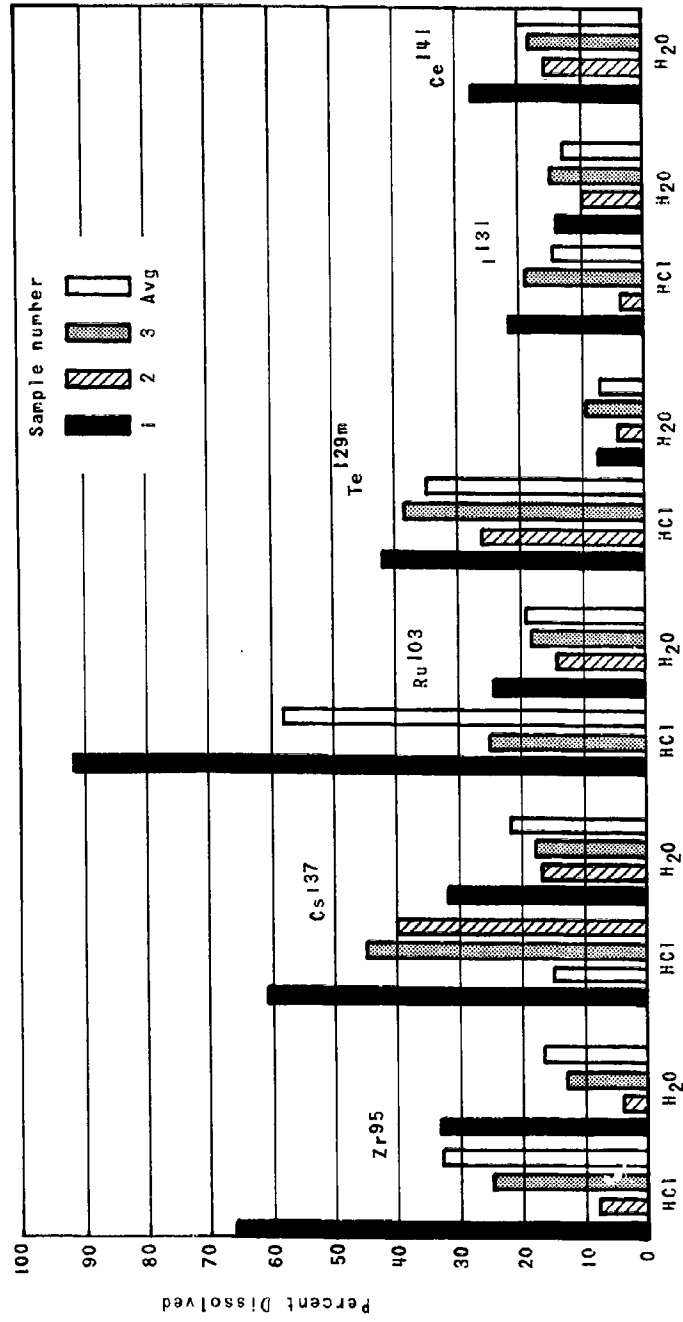

Figure 15. Solubility of Various Isotopes in Distilled Water and 0.5% by Volume Aqueous HCl

4.4.6 Particle-Size Distribution

Particle-size information for the six effluent nuclides was obtained from activities measured in the Andersen samplers and back-up filters stationed on the 50-meter arc. Ten of the thirteen samplers (5-degree spacing) collected sufficient activity to provide a reasonable statistical distribution of the effluent constituents 50 meters downwind from the source. A resume of these activities averaged for each stage across the arc is shown in Figure 16 and Table 9. The percentages with standard deviations indicate the relative distribution of each radioisotope as collected in the sampler, backup filter, and carbon cartridge. On the 100-meter arc only one sampler (Sta. 26) received enough activity to provide measurements of the effluent (Table 9).

Since the density of the particles to which the radionuclide might have adhered is not known, no definite statements can be made as to particle size of the individual radionuclides on each stage of the Andersen sampler. However, from calibration data determined for various particle densities and a flow rate of 1.4 cfm (Ref. 1), Figure 17 indicates that, over a range of densities, any particles collected on Stage 6 and the backup filter system would be less than 1 micron in diameter. Assuming the effluent sampled is in this density range, then approximately 73 to 88 percent of the fission-product activity on the 50-meter arc was associated with particles below 1 micron in diameter (Table 9).

Since only one sampler on the 100-meter arc contained sufficient activity for analysis, there is some doubt as to the validity

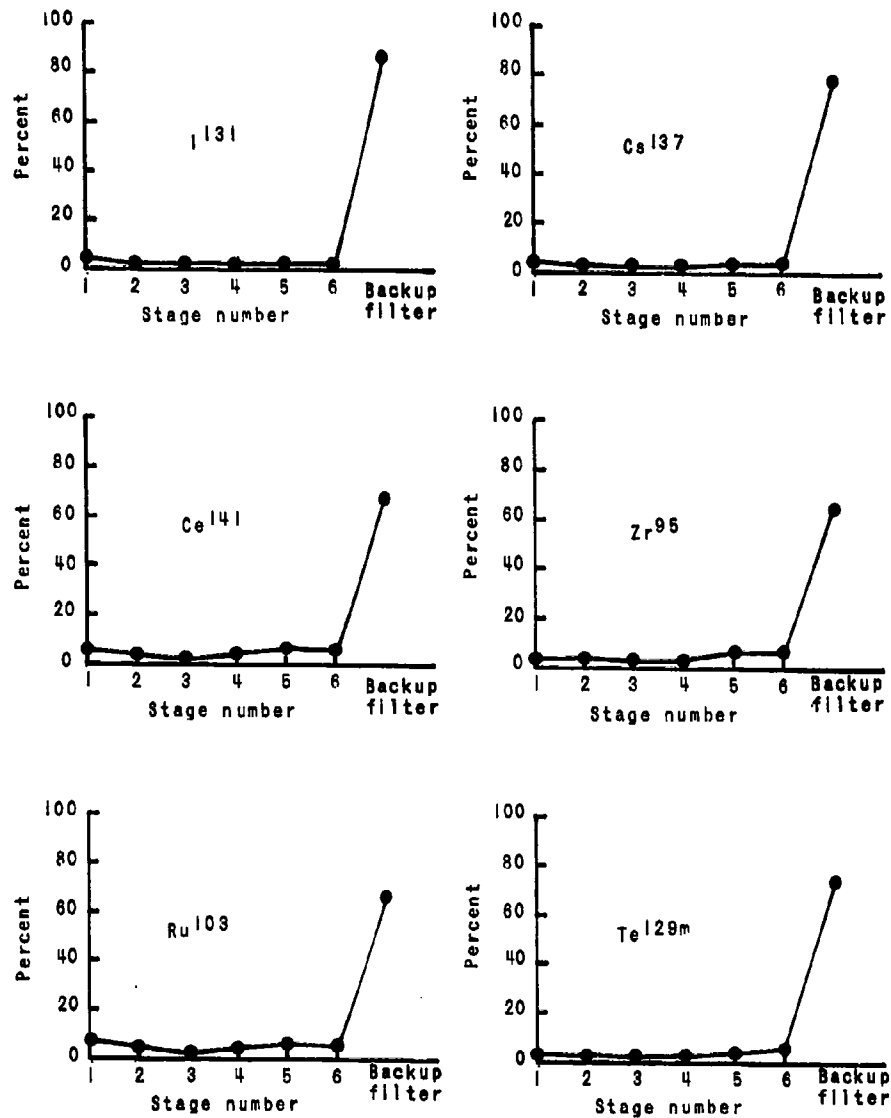

Figure 16. Percent Isotopic Activity Per Stage (50-Meter Arc)

TABLE 9
 Percent of Andersen Sampler Activity Collected by Each Stage
 (Avg of 10 stations) 50-Meter Arc

Sampler Stage Number	Isotope					
	Zr-95	Cs-137	Ru-103	Te-129m	I-131	Ce-141
1	4.5 ± 2.1	4.3 ± 1.8	7.6 ± 2.5	4.7 ± 1.3	5.7 ± 0.8	6.4 ± 0.9
2	5.1 ± 1.9	3.0 ± 0.6	5.3 ± 1.8	3.6 ± 0.8	2.5 ± 0.3	4.6 ± 1.9
3	4.6 ± 1.7	1.8 ± 0.6	1.7 ± 0.7	2.6 ± 1.2	0.9 ± 0.3	2.8 ± 1.0
4	3.8 ± 1.8	2.1 ± 0.6	5.0 ± 2.1	3.1 ± 0.9	1.0 ± 0.3	5.4 ± 2.1
5	7.7 ± 2.4	4.6 ± 0.8	7.0 ± 1.5	4.8 ± 0.8	1.3 ± 0.3	7.1 ± 2.3
6	8.1 ± 1.7	4.6 ± 0.6	6.3 ± 1.4	6.6 ± 0.9	2.2 ± 0.6	5.9 ± 1.0
Backup Filter Chain	66 ± 7	80 ± 3	67 ± 7	75 ± 3	86 ± 2	68 ± 6

100-Meter Arc - Station 26

Sampler Stage Number	Isotope					
	Zr-95	Cs-137	Ru-103	Te-129m	I-131	Ce-141
1	-	2.0	3.7	2.5	6.1	-
2	4.7	2.2	1.0	0.3	2.4	-
3	4.7	1.6	1.0	0.4	1.5	-
4	-	1.1	1.2	0.7	0.2	-
5	9.5	2.2	4.5	3.0	0.6	-
6	-	2.3	-	-	-	-
Backup Filter Chain	81	89	89	93	89	100

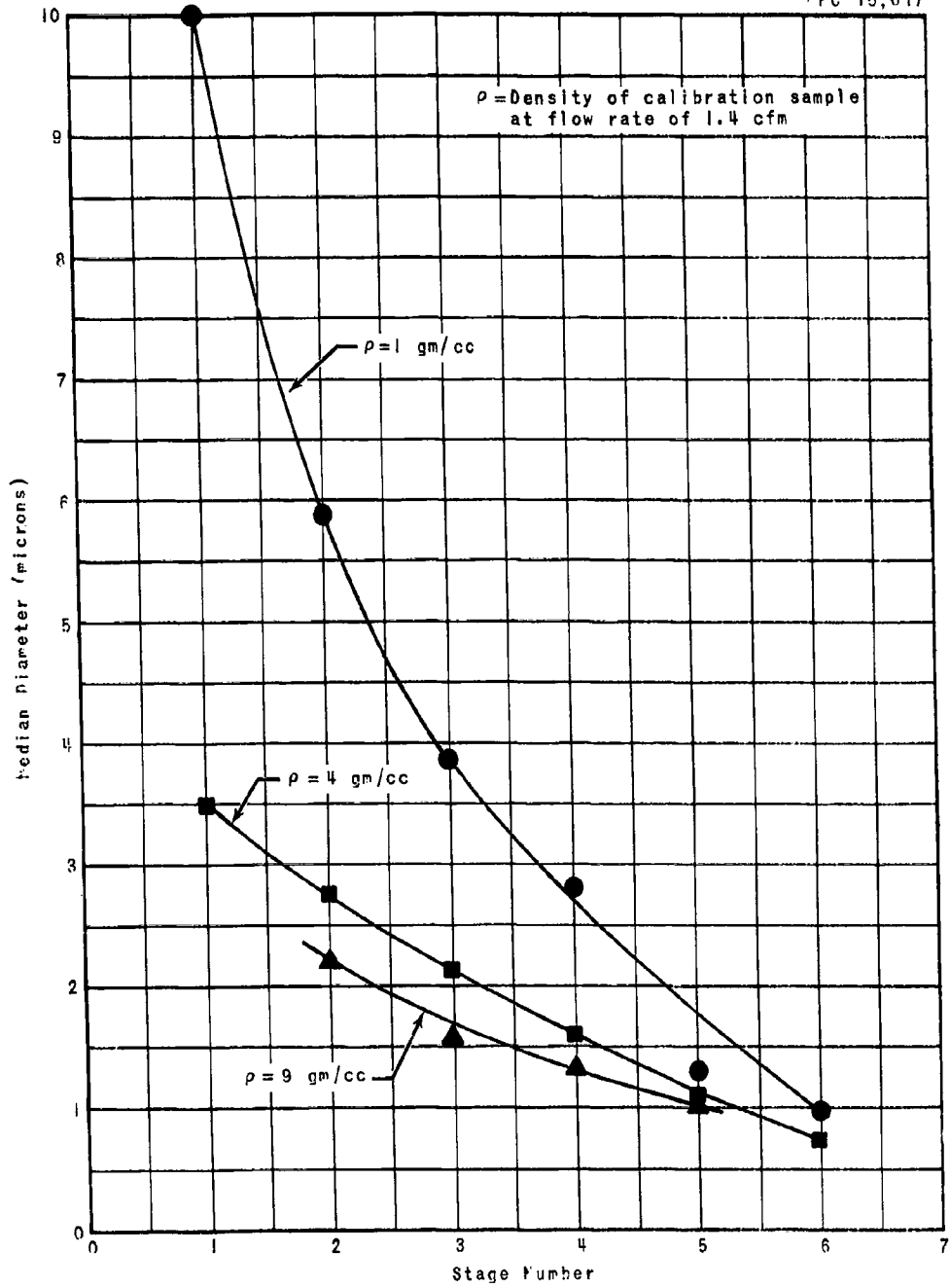

Figure 17. Andersen Sampler Calibration

of any conclusions drawn from these data. Table 9 indicates, however, that the percentage of activity associated with particles less than 1 micron in diameter was greater than that found on the 50-meter arc.

4.5 Meteorological Conditions Existing During Tests

In consideration of the normal seasonal wind patterns at NRTS, the occurrence of persistent southwesterly winds favorable for both closed and open releases over the sampling network was considerably less than expected. The amount of cloud cover (mostly cumulus) observed was above normal. The clouds, when scattered, caused uneven heating at the surface and, in turn, erratic wind patterns. Gustiness and variation in wind direction and velocity were of such high frequency during lapse periods that considerable difficulty was incurred in the planning and scheduling of releases.

A summary of release conditions is given in Table 10. While the mean wind velocities appeared quite acceptable for each release, the deviations (maximum ranges) occurring during the periods of furnace heating were quite large and in some instances beyond prescribed tolerances. In the case of the fourth release, the winds tended to scatter the effluent over most of the 60-degree network.

TABLE 10
Summary of Release Conditions

Release No. & Type	Date ** Decay Time	Meteorological Conditions During Runs*										Relative Humidity (%)	
		Mean Wind				Mean Temp			Max. Range (± m/s)	Velocity (m/s)	2m (°F)		Δt (°F) t _{32-t₁}
		Direction (deg)	Max. Range (± deg)	Velocity (m/s)	Tower Level (m)								
1 Closed	7/25 20d	186	21	7.8	4.0	93.2	-4.1	19					
		170	27	6.1	3.1	93.2	-4.1						
		165	30	4.2	1.9								
		166	26	5.6	1.8								
2 Closed	7/27 22d	220	11	9.2	4.8			93.5	-3.8	15			
		205	24	6.2	2.9								
		210	25	5.8	3.5								
		205	30	6.7	2.3								
3 Closed	7/31 26d	240	40	4.2	1.2	91.4	-2.4	22					
		239	41	4.0	1.3								
		236	45	2.6	1.5								
		233	47	4.8	1.1								
4 Open	8/10 36d	234	41	4.0	2.0	92.0	-3.7	9					
		235	32	3.6	1.7								
		234	42	3.1	1.6								
		224	39	3.5	1.5								

*Meteorological conditions during time when furnace was at power.
** Decay time is the days elapsed between irradiation completion (5 Jul 61) and melt.

V. SUMMARY AND CONCLUSIONS

5.1 Summary

The objective of this series of tests was to determine fission-product release percents by analyses of the melt residues and total-effluent collectors from three closed releases. Due to the difficulty in dissolving the melt residue, inventories determined from radiochemical analyses of unmelted pins were used with data obtained from the total-effluent collectors to determine the release percents from the closed releases. Release percents were also determined from network data. A secondary purpose of the tests was to obtain solubility data, particle sizing, and deposition velocities from one open release.

5.1.1 Release Percents

Table 11 compares release percents obtained from FRT-III with release percents found in FRT-I and -II. It was not expected that the release percents would be the same for each series of tests since the fuel pins were of different materials and thus the melting temperatures were much higher for FRT-II than the other two series of tests. However, comparison of the three releases does show similar results even with these varying factors. The strontium release percent from FRT-III total-effluent collector appears low, however, due to a radiochemical analysis discrepancy in determining the Sr-90 inventory (Sec. 4.2). This number agrees more closely with previous tests if multiplied by 8 (the factor between calculated and radiochemical analysis fission product inventories, Table 2).

TABLE II
Release Percents from FRT-I, -II, and -III

	FRT-I		FRT-II		FRT-III	
	Total Effluent Collector	Network	Total Effluent Collector	Network	Total Effluent Collector	Network
Iodine	44		24 + 13	24*	56	45 ± 3
Cesium	55 ± 19		5.7 ± 3.8	13 ± 7	65	65*
Barium-Lanthanum	-		0.021 ± 0.019	-	-	-
Ruthenium	0.73 ± 0.16		0.09 ± 0.10	0.70 ± 0.60	-	0.53 ± 0.09
Cerium	0.10 ± 0.16		0.0094 ± 0.0071	-	0.010 ± 0.004	0.14 ± 0.02
Strontium	0.71 ± 0.61		0.0090 ± 0.0095	-	0.0012 ± 0.0006	-
Tellurium	-		-	0.44 ± 0.23	-	2.1 ± 0.10
Zirconium	0.073 ± 0.13		-	-	-	0.11 ± 0.01
Gross Gamma	31 ± 21		0.0093 ± 0.0074	-	-	45**
Uranium	-		-	-	0.39 ± 0.09	-
Beryllium	-		-	-	0.03	-

*Normalizing number for other release percents

**Ion chamber pre- and post-melt gross-gamma readings of melt sample

5.1.2 Particle Size

The results of FRT-III particle sizing obtained from 50-meter arc data are shown in Table 12.

TABLE 12
Summary of Particle Size Data
50-Meter Arc

Isotope	Percentage of Activity Associated with Particles of Median Dia. < 1 Micron
I-131	88
Ce-141	73
Zr-95	74
Ru-103	73
Cs-137	84
Te-129m	81

These numbers can be compared with results of 100-meter-arc data from FRT-I and -II in which roughly 85 percent of all iodine, cesium and ruthenium activity was associated with particles that had a median diameter of less than 1 micron.

5.1.3 Deposition Velocity

Table 13 compares the deposition velocities obtained from gummed paper and air sampler data of FRT-I, FRT-II, and FRT-III. It was expected that the FRT-III data would compare more favorably with FRT-I than it did, since both tests were performed at

the same test site; however, the FRT-III data represent only one release whereas FRT-I data are averages of a number of releases.

TABLE 13
Deposition Velocities from FRT-I, -II, and -III
(Gummed Paper)

Isotope	FRT-I	FRT-II	FRT-III
Cs-137	0.10 ± .06	0.21 ± .27	0.28 ± .06
I-131	1.1 ± .4	0.28 ± .39	0.50 ± .05
Ru-103	2.0 ± 1.0	0.34 ± .31	0.73 ± .12
Zr-95	1.4 ± .7	-	0.29 ± .04
Te-129m	-	0.71 ± 1.3**	0.27 ± .07
Ce-141	0.73 ± .63	-	0.15 ± .02
Average Relative Humidity	21%	55%	9%
Average Wind Velocity	3.9 m/sec	3.6 m/sec	3.5 m/sec

**Based on Te-127m and Te-129m data

5.1.4 Solubility

The data on solubility are rather limited; however, they do show the nuclides investigated are relatively more soluble in acidic than in neutral media, and that the more active metallic

constituents display the greatest solubilities. No solubility data were obtained from FRT-I and FRT-II for comparison purposes.

5.1.5 Activity Release Heights

During FRT-I vertical profiles were taken four feet downwind from the furnace. Maximum cloud concentration occurred at approximately 1.7 meters above ground level; the furnace lip was 1.5 meters above ground level. During FRT-II and FRT-III, the furnace lips were again at 1.5 meters. Vertical profiles were taken at 50 meters downwind, with maximum concentrations at 2.1 meters during FRT-II and at 2 meters during FRT-III. Therefore, in all three tests the maximum cloud concentration occurred at approximately the same level, this level being only slightly higher than the lip of the furnace.

5.2 Conclusions

- When PLUTO-type fuel elements are subjected to meltdown conditions, relatively large amounts of iodine and cesium (>45% each) are released along with lesser amounts of other fission products.
- At least 78% of the fission products released from the meltdown of the PLUTO-type elements are associated with particles with diameters of less than 1 micron when collected at distances greater than 50 meters from the point of release.
- Fission products released from PLUTO-type fuel elements tend to be more soluble in stomach fluids than in the fluids found in the lungs.
- When $\text{UO}_2\text{-BeO}$ fuel is melted in air in the presence of tantalum, it is converted to a residue that is essentially insoluble in either single or mixed acids.

REFERENCES

1. Fission Products Field Release Test I. Convair-Fort Worth Report FZK-9-140 (NARF-59-32T, September 1959). U
2. Fission Products Field Release Test II. Convair-Fort Worth Report FZK-9-149 (NARF-60-10T, September 1960). U
3. Olsen, D. G., Quantitative Gamma-Ray Spectrometric Analysis of Nuclide Mixtures Consecutive Standard Sources Nullification. U.S.A.E.C. Report No. IDO-14495 (November 1959). U

DISTRIBUTION

No. Cys

2	ASD (Aeronautical Systems Division), (ASRSMX-3), Wright-Patterson AFB, Ohio AFSWC, Kirtland AFB, NM
30	(SWOI)
1	(SWRB)
2	US Atomic Energy Commission, Division of Reactor Development, (PLUTO Branch), Wash 25, DC
6	General Dynamics/ Fort Worth, Fort Worth, Tex
1	Phillips Petroleum Company, (NRTS), Idaho Falls, Idaho
1	Official Record Copy, (SWRB, Capt Larson)
10	ASTIA (TIPDR), Arlington Hall Sta., Arlington 12, Va

<p>Air Force Special Weapons Center, Kirtland AF Base, New Mexico Rpt. No. AFSCC-TDR-62-54. FISSION PRODUCTS FIELD RELEASE TEST III. Dec 62, 72 P, incl illus., tables, 3 refs. Unclassified Report</p> <p>A series of field experiments (FRP-III) was conducted to determine the types and quantities of radioactivity that might be released during the meltdown of a PLUTO-type reactor. Four fission-product releases from the melting of segments of freshly irradiated UO₂-BeO ceramic unclad fuel elements were made at the National Reactor Testing Station (NRTS) in Idaho during the summer of 1961. The fuel samples were melted in high-temperature induction furnaces; three releases were made into collectors designed to trap 100% of the released fission products (with the</p>	<ol style="list-style-type: none"> 1. Ceramics 2. Gamma spectroscopy 3. Fission products 4. Particle size measurement 5. Plutonium-radiation effects 6. Radioactivity 7. Radiochemical analysis 8. Reactor fuels 9. Sample collection 10. Test facilities I. AFSC Project 655A II. Contract AF 29(601)4581 III. General Dynamics/Fort Worth, Fort Worth, Tex. IV. Secondary Rpt No. FZK-153 	<p>Air Force Special Weapons Center, Kirtland AF Base, New Mexico Rpt. No. AFSCC-TDR-62-54. FISSION PRODUCTS FIELD RELEASE TEST III. Dec 62, 72 P, incl illus., tables, 3 refs. Unclassified Report</p> <p>A series of field experiments (FRP-III) was conducted to determine the types and quantities of radioactivity that might be released during the meltdown of a PLUTO-type reactor. Four fission-product releases from the melting of segments of freshly irradiated UO₂-BeO ceramic unclad fuel elements were made at the National Reactor Testing Station (NRTS) in Idaho during the summer of 1961. The fuel samples were melted in high-temperature induction furnaces; three releases were made into collectors designed to trap 100% of the released fission products (with the</p>	<ol style="list-style-type: none"> 1. Ceramics 2. Gamma spectroscopy 3. Fission products 4. Particle size measurement 5. Plutonium-radiation effects 6. Radioactivity 7. Radiochemical analysis 8. Reactor fuels 9. Sample collection 10. Test facilities I. AFSC Project 655A II. Contract AF 29(601)4581 III. General Dynamics/Fort Worth, Fort Worth, Tex. IV. Secondary Rpt No. FZK-153
<p>Air Force Special Weapons Center, Kirtland AF Base, New Mexico Rpt. No. AFSCC-TDR-62-54. FISSION PRODUCTS FIELD RELEASE TEST III. Dec 62, 72 P, incl illus., tables, 3 refs. Unclassified Report</p> <p>A series of field experiments (FRP-III) was conducted to determine the types and quantities of radioactivity that might be released during the meltdown of a PLUTO-type reactor. Four fission-product releases from the melting of segments of freshly irradiated UO₂-BeO ceramic unclad fuel elements were made at the National Reactor Testing Station (NRTS) in Idaho during the summer of 1961. The fuel samples were melted in high-temperature induction furnaces; three releases were made into collectors designed to trap 100% of the released fission products (with the</p>	<ol style="list-style-type: none"> 1. Ceramics 2. Gamma spectroscopy 3. Fission products 4. Particle size measurement 5. Plutonium-radiation effects 6. Radioactivity 7. Radiochemical analysis 8. Reactor fuels 9. Sample collection 10. Test facilities I. AFSC Project 655A II. Contract AF 29(601)4581 III. General Dynamics/Fort Worth, Fort Worth, Tex. IV. Secondary Rpt No. FZK-153 	<p>Air Force Special Weapons Center, Kirtland AF Base, New Mexico Rpt. No. AFSCC-TDR-62-54. FISSION PRODUCTS FIELD RELEASE TEST III. Dec 62, 72 P, incl illus., tables, 3 refs. Unclassified Report</p> <p>A series of field experiments (FRP-III) was conducted to determine the types and quantities of radioactivity that might be released during the meltdown of a PLUTO-type reactor. Four fission-product releases from the melting of segments of freshly irradiated UO₂-BeO ceramic unclad fuel elements were made at the National Reactor Testing Station (NRTS) in Idaho during the summer of 1961. The fuel samples were melted in high-temperature induction furnaces; three releases were made into collectors designed to trap 100% of the released fission products (with the</p>	<ol style="list-style-type: none"> 1. Ceramics 2. Gamma spectroscopy 3. Fission products 4. Particle size measurement 5. Plutonium-radiation effects 6. Radioactivity 7. Radiochemical analysis 8. Reactor fuels 9. Sample collection 10. Test facilities I. AFSC Project 655A II. Contract AF 29(601)4581 III. General Dynamics/Fort Worth, Fort Worth, Tex. IV. Secondary Rpt No. FZK-153

<p>exception of the noble gases) and one release was made to the atmosphere. The experimental design and techniques used in analyzing the data from these tests are described. Experimental results such as release percent, particle-size distribution, air and ground concentration, deposition velocity, and solubility are given.</p> <p style="text-align: center;">○</p>		<p>exception of the noble gases) and one release was made to the atmosphere. The experimental design and techniques used in analyzing the data from these tests are described. Experimental results such as release percent, particle-size distribution, air and ground concentration, deposition velocity, and solubility are given.</p> <p style="text-align: center;">○</p>	
<p>exception of the noble gases) and one release was made to the atmosphere. The experimental design and techniques used in analyzing the data from these tests are described. Experimental results such as release percent, particle-size distribution, air and ground concentration, deposition velocity, and solubility are given.</p> <p style="text-align: center;">○</p>		<p>exception of the noble gases) and one release was made to the atmosphere. The experimental design and techniques used in analyzing the data from these tests are described. Experimental results such as release percent, particle-size distribution, air and ground concentration, deposition velocity, and solubility are given.</p> <p style="text-align: center;">○</p>	