

UNCLASSIFIED

AD NUMBER
AD296056
NEW LIMITATION CHANGE
TO Approved for public release, distribution unlimited
FROM Distribution authorized to U.S. Gov't. agencies and their contractors; Administrative/Operational Use; 18 FEB 1962. Other requests shall be referred to National Aeronautics and Space Administration, Washington, DC.
AUTHORITY
NASA TR Server website

THIS PAGE IS UNCLASSIFIED

**UNCLASSIFIED**

---

---

**AD. 296 056**

*Reproduced  
by the*

**ARMED SERVICES TECHNICAL INFORMATION AGENCY  
ARLINGTON HALL STATION  
ARLINGTON 12, VIRGINIA**



---

---

**UNCLASSIFIED**

---

NOTICE: When government or other drawings, specifications or other data are used for any purpose other than in connection with a definitely related government procurement operation, the U. S. Government thereby incurs no responsibility, nor any obligation whatsoever; and the fact that the Government may have formulated, furnished, or in any way supplied the said drawings, specifications, or other data is not to be regarded by implication or otherwise as in any manner licensing the holder or any other person or corporation, or conveying any rights or permission to manufacture, use or sell any patented invention that may in any way be related thereto.

AU NO. 296056  
ADIA FILE COPY

296056

A COMPARISON OF OCULAR COUNTERROLLING MOVEMENTS  
BETWEEN NORMAL PERSONS AND DEAF SUBJECTS WITH  
BILATERAL LABYRINTHINE DEFECTS

By

Earl F. Miller II and Ashton Graybiel



JOINT REPORT

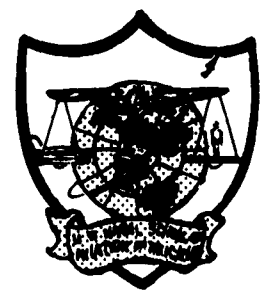

UNITED STATES NAVAL SCHOOL OF AVIATION MEDICINE

AND

NATIONAL AERONAUTICS AND SPACE ADMINISTRATION

U. S. Naval School of Aviation Medicine  
U. S. Naval Aviation Medical Center  
Pensacola, Florida

296 056

FEB 13 1963

FOR OFFICIAL USE ONLY  
MAY BE RELEASED ON  
18 FEBRUARY 1962

# Research Report

A COMPARISON OF OCULAR COUNTERROLLING MOVEMENTS  
BETWEEN NORMAL PERSONS AND DEAF SUBJECTS WITH  
BILATERAL LABYRINTHINE DEFECTS\*

Earl F. Miller II and Ashton Graybiel

Bureau of Medicine and Surgery  
Project MR005.13-6001  
Subtask 1                      Report No.68

NASA ORDER No. R-47

Released By

Captain Clifford P. Phoebus, MC, USN  
Commanding Officer

\*This research was conducted under the sponsorship of the Office of Life  
Science Programs, National Aeronautics and Space Administration.

**U. S. NAVAL SCHOOL OF AVIATION MEDICINE**  
**U. S. NAVAL AVIATION MEDICAL CENTER**  
**PENSACOLA, FLORIDA**

## SUMMARY PAGE

### THE PROBLEM

Recent investigations have advanced our knowledge of counterrolling and its measurement. This report represents a further attempt with more precise techniques and several carefully selected labyrinthine defective (L-D) subjects to define the reliability and validity of counterrolling as a functional test of the otolith organs.

Ocular counterrolling as a function of head (body) tilt in the frontal plane was measured in nine healthy persons and ten deaf subjects with bilateral loss of function of the semicircular canals; the functional status of the otoliths was unknown.

### FINDINGS

A photographic technique was used taking advantage of natural landmarks on the iris which ensured a high degree of reliability in measurement. Measurements of several photographs at each body position disclosed a small but significant variation in both groups of subjects which was interpreted as "instability" of torsional eye position; it was approximately the same upright as in the tilt positions ( $25^{\circ}$ ,  $50^{\circ}$ , and  $75^{\circ}$  left and right).

The findings in the normal subjects revealed a characteristic pattern of counterrolling. Torsion as a function of tilt rightward or leftward was greatest in the first 25 degrees from the upright, less from 25 to 50 degrees where it usually reached peak value, and thereafter in most cases tended to reverse direction. There were significant right-left differences in some cases but not in others. The average maximum value (counterrolling "index" CI, of otolith function) calculated as one-half the difference between right-left torsion, ranged from 286 to 465 minutes of arc.

The findings in the L-D subjects did not disclose the characteristic pattern found in normal subjects in most instances, and the CI ranging from 30 to 176 minutes of arc, showed no overlap with the normals. In some instances, there was no definite evidence of counterrolling, in others it was limited to one direction of tilt, and in still others there was a small but regular dependence of counterroll with the successive increases in bodily tilt. The highly significant group differences must have been due to loss of function of the auricular sensory organs, and intraindividual differences in the L-D group are best explained by the presence of some residual otolith function.

### ACKNOWLEDGMENTS

The authors gratefully acknowledge the cooperation of the following persons who acted as subjects in this study: J. M. Jordan, H. J. Domich, D. O. Peterson, D. W. Myers, C. R. Harper, R. E. Piper, J. P. Zakutney, A. E. Steele, H. L. Lawson, B. I. Gulak, B. A. Cyr, R. B. Hunt, R. W. Smith, C. C. Nugent, D. B. Gillis, T. F. Thurman, G. Zel, L. W. Hill, and T. R. Hays.

Miller, E. F. II  
A. Graybiel

1962

A COMPARISON OF OCULAR COUNTERROLLING MOVEMENTS BETWEEN NORMAL PERSONS AND DEAF SUBJECTS WITH BILATERAL LABYRINTHINE DEFECTS. BuMed Project MR005. 13-6001 Subtask 1, Report No. 68 and NASA Order No. R-47. Pensacola, Fla.: Naval School of Aviation Medicine, 18 February.

Counterrolling as a function of head (body) tilt was measured by a photographic technique in nine normal and ten labyrinthine defective (L-D) subjects to determine the functional status of their otolith organs. The findings in the normal subjects revealed a characteristic pattern of counterrolling. Ocular torsion as a function of head tilt rightward or leftward was greatest in the first 25 degrees from the upright, less from 25 to 50 degrees where it usually reached peak value, and thereafter in most cases tended to reverse direction. The average maximum value (counterrolling index, CI) ranged from 286 to 465 minutes of arc. The L-D subjects did not disclose the "normal" counterrolling pattern in most instances and their CI ranged from only 30 to 176 minutes of arc. The highly significant intergroup differences were attributed to loss of function of the auricular sensory organs; intraindividual differences in the L-D group were explained by the presence of some residual otolith function.

Eye - Measurement

Ear - Sense organs

Otoliths

Eye movements -  
Counterrolling

L. C. Subj. Head.

Miller, E. F. II  
A. Graybiel

1962

A COMPARISON OF OCULAR COUNTERROLLING MOVEMENTS BETWEEN NORMAL PERSONS AND DEAF SUBJECTS WITH BILATERAL LABYRINTHINE DEFECTS. BuMed Project MR005. 13-6001 Subtask 1, Report No. 68 and NASA Order No. R-47. Pensacola, Fla.: Naval School of Aviation Medicine, 18 February.

Counterrolling as a function of head (body) tilt was measured by a photographic technique in nine normal and ten labyrinthine defective (L-D) subjects to determine the functional status of their otolith organs. The findings in the normal subjects revealed a characteristic pattern of counterrolling. Ocular torsion as a function of head tilt rightward or leftward was greatest in the first 25 degrees from the upright, less from 25 to 50 degrees where it usually reached peak value, and thereafter in most cases tended to reverse direction. The average maximum value (counterrolling index, CI) ranged from 286 to 465 minutes of arc. The L-D subjects did not disclose the "normal" counterrolling pattern in most instances and their CI ranged from only 30 to 176 minutes of arc. The highly significant intergroup differences were attributed to loss of function of the auricular sensory organs; intraindividual differences in the L-D group were explained by the presence of some residual otolith function.

Miller, E. F. II  
A. Graybiel

1962

A COMPARISON OF OCULAR COUNTERROLLING MOVEMENTS BETWEEN NORMAL PERSONS AND DEAF SUBJECTS WITH BILATERAL LABYRINTHINE DEFECTS. BuMed Project MR005. 13-6001 Subtask 1, Report No. 68 and NASA Order No. R-47. Pensacola, Fla.: Naval School of Aviation Medicine, 18 February.

Counterrolling as a function of head (body) tilt was measured by a photographic technique in nine normal and ten labyrinthine defective (L-D) subjects to determine the functional status of their otolith organs. The findings in the normal subjects revealed a characteristic pattern of counterrolling. Ocular torsion as a function of head tilt rightward or leftward was greatest in the first 25 degrees from the upright, less from 25 to 50 degrees where it usually reached peak value, and thereafter in most cases tended to reverse direction. The average maximum value (counterrolling index, CI) ranged from 286 to 465 minutes of arc. The L-D subjects did not disclose the "normal" counterrolling pattern in most instances and their CI ranged from only 30 to 176 minutes of arc. The highly significant intergroup differences were attributed to loss of function of the auricular sensory organs; intraindividual differences in the L-D group were explained by the presence of some residual otolith function.

Eye - Measurement

Ear - Sense organs

Otoliths

Eye movements -  
Counterrolling

L. C. Subj. Head.

Eye - Measurement

Ear - Sense organs

Otoliths

Eye movements -  
Counterrolling

L. C. Subj. Head.

Eye - Measurement

Ear - Sense organs

Otoliths

Eye movements -  
Counterrolling

L. C. Subj. Head.

## INTRODUCTION

Recent reports (1-4) from this laboratory have reviewed the literature on counter-rolling of the eyes as a function of body tilt, described new techniques for measurement of the roll, and discussed its significance as a test of otolith function. This report represents a further step in defining the reliability and validity of counterrolling as a functional test of the otolith organs by comparing measurements obtained from a group of healthy persons with those from a carefully selected group of subjects with labyrinthine defects.

## PROCEDURE

### SUBJECTS

The significant clinical findings in the ten subjects with labyrinthine defects, hereafter termed L-D subjects, are summarized in Table I. These subjects represent a highly selected group of instructors and students from Gallaudet College in Washington, D. C. The nine normal subjects were students (seven were medical students) in good health, and careful evaluation revealed normal hearing and normal perception of the oculogravic illusion. All of the subjects had participated in a series of experiments of which this was one and had demonstrated excellent and intelligent cooperation.

### APPARATUS

The apparatus consisted of a chair, mounted on a ring support, which could be rotated by means of a hydraulic power system 75 degrees in a clockwise or counterclockwise direction from the upright (zero degree) position. Provision was made for ensuring body restraint within the chair in all positions of tilt, by various belts, straps, and side supports. The subject's head position, considered more critical, was held rigid by 1) a bite bar, 2) a horizontal metal band which wrapped around the forehead and forced the head firmly back into a v-shaped support lined with dense foam rubber, and 3) a wide metal band extending over the top of the head. The bite bar and forehead band were covered with dental impression material and individually fitted to each subject. A 35 mm camera equipped with telephoto lens and bellows was mounted on a bracket attached to the "ring" in front of the subject. It was supported on a stage which could be precisely moved along the three major coordinates in space and locked in position. As a result, the camera and head (body) were tilted as a unit. An electronic flash unit was positioned for illumination of the subject's right eye. A small target requiring foveal fixation for resolution was centered within the camera lens by reflection in a clear glass plate.

Table I

## Clinical Findings and Results of Functional Tests of Auricular Organs in Subjects with Labyrinthine Defects

Subj	Age	Deafness		History	Hearing		Caloric Test*	
		Etiology	Age of Onset		Motion Sickness	R	L	R
ST	20	Meningitis	12-1/2 yrs.	Car, bust	≥ 130 db	≥ 135 db	<sup>1</sup> Neg	<sup>1</sup> Neg
PE	33	Meningitis	12 yrs.	None	None	None	Neg	Neg
GU	21	Meningitis	4-1/2 yrs.	None	≥ 145 db	≥ 145 db	<sup>2</sup> Neg	<sup>3</sup> Neg
HR	29	Meningitis	13 yrs.	Small boat #	None	None	Neg	Neg
LA	23	Meningitis	6 yrs.	None	≥ 115 db	≥ 110 db	None	None
ZA	20	Meningitis	3-1/2 yrs.	None	≥ 135 db	≥ 130 db	None	None
JO	34	Meningitis	7-1/2 yrs.	None	None	None	None	None
MY	25	Meningitis	8 yrs.	None	None	None	None	None
DO	43	Meningitis	13 yrs.	None	None	None	None	None
PI	22	Meningitis	3 yrs.	None	None	None	<sup>4</sup> None	<sup>5</sup> None

\*Observable nystagmus when tympanum irrigated with cold water (4.5-6°C); numerals refer to nystagmographic findings.

1. ?vertical nystagmus, 2. ?nystagmus, 3. minimal nystagmus, 4. "blink" nystagmus, 5. not tested.  
 +Nausea #Malaise

## METHOD

After the subject was positioned in the tilt chair and all his supportive appliances attached, he was requested to fixate the target. The left eye was occluded with an opaque patch. The camera was then adjusted so that the subject's right eye was in focus and centered on the ground glass screen. The chair was tilted at about  $1^\circ/\text{sec}$  laterally around the subject's frontal plane in steps of 25 degrees, first clockwise from the upright (zero degrees) starting position until the limit of +75 degrees was reached. Next the subject was returned to zero degrees and then tilted counterclockwise, in succession, -25, -50, and -75 degrees. After rotation to each position, at least two minutes elapsed before the eye was photographed. Photographs were taken on at least four separate occasions at each angle of tilt.

Counterrolling was measured by superimposition of photographs of the eye obtained with the subject upright (reference image) and when tilted (test image). The latter photograph was rotated until landmarks on the two images of the iris were aligned. The equipment used is illustrated in Figure 1. Two standard slide projectors (P1, P2), one of which was equipped with an adjustable film strip holder, were positioned at right angles to each other. A pellicle (PL) reflecting surface (reflectance: transmittance, 1:1), at an angle of 45 degrees to both projectors, was used to superimpose the two projected images (enlarged about 300 times actual size) on a screen placed at a distance of 20 feet. A device (C) containing a dove prism was placed before one projector. Rotation of the prism in minutes of arc was indicated by a circular vernier scale. Four measurements were made on each photograph and, as found in a previous study (4), the mean deviation, on the average, equalled about  $\pm 5$  minutes of arc.

## RESULTS

Average counterrolling values in minutes of arc as a function of leftward and rightward tilt are given in Table II and plotted as closed circles in Figure 2, for both groups of subjects: normals, left hand column and L-D, righthand column. Plotted as open circles in Figure 2 are the values obtained for different trials at a given body position. It is seen that there was considerable variance in these values and that this variance was about the same for both groups of subjects and for all body positions. This variance was greater than one degree in about one fourth of the series of measurements for each body position. In an earlier communication (1), it was pointed out that some of the variance might be due to "dynamic instability" of the eye at any given body position. Occasional gross differences might have been due to loss of fixation or shift in head position.

The values for the normal subjects show a relatively high ratio of counterrolling to tilt in the first 25 degrees from the upright, a lower ratio between 25 and 50 degrees, and usually a reversal in direction between 50 and 75 degrees (Figure 2). The pattern is similar for all normal subjects in both leftward and rightward tilt. The counterrolling index (CI), calculated as one-half the difference between the greatest mean right and

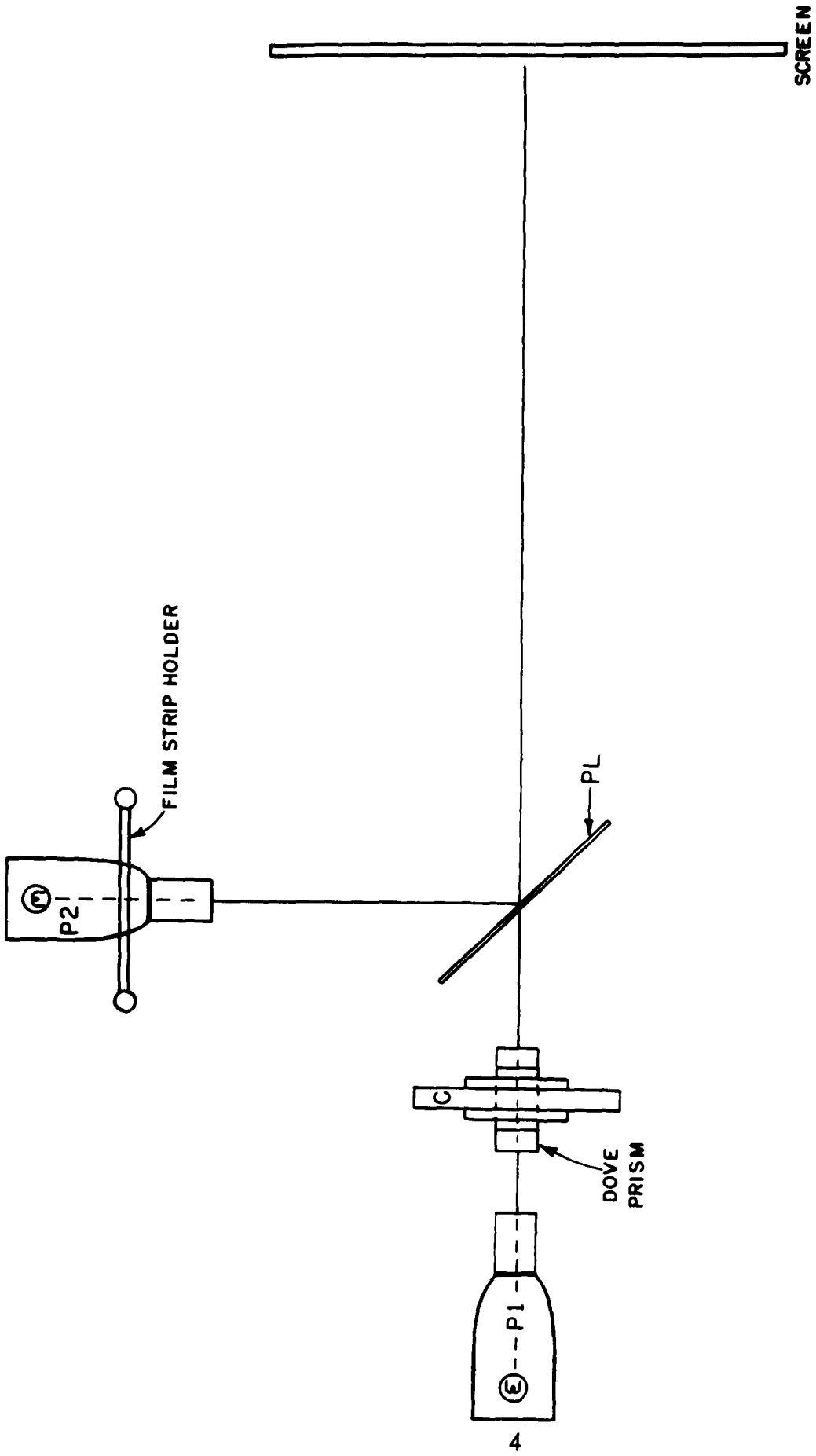

Figure 1

Equipment Used in Measuring Counterolling on Photographs of the Eye

Table II

Mean Counterrolling Values in Minutes of Arc as a Function of Head (Body) Tilt for Normal and Labyrinthine Defective Subjects Ranked According to Their Counterrolling Index (CI)

Normal Subjects	-75	-50	-25	+25	+50	+75	CI
HY	505	459	338	-286	-399	-424	465
FE	227	298	247	-345	-481	-452	390
GI	416	395	270	-339	-325	-290	378
CY	309	319	195	-302	-359	-344	339
TH	367	383	257	-231	-293	-263	338
SM	242	256	230	-289	-381	-407	332
HI	254	309	274	-263	-329	-307	319
NU	286	253	226	-246	-297	-315	301
HU	188	188	132	-244	-384	-336	286
<u>L-D Subjects</u>							
JO	187	124	93	-137	-128	-165	176
ST	20	68	17	-165	-152	-162	117
LA	131	93	53	-18	-53	-86	109
GU	70	59	46	-84	-94	-107	89
PI	65	60	27	-83	-69	-105	85
MY	101	78	70	-51	-48	-63	82
DO	49	69	49	-32	-79	-55	74
HR	31	33	26	-36	-62	-73	53
ZA	48	6	0	+20	-23	+9	36
PE	18	24	2	-20	-18	-35	30

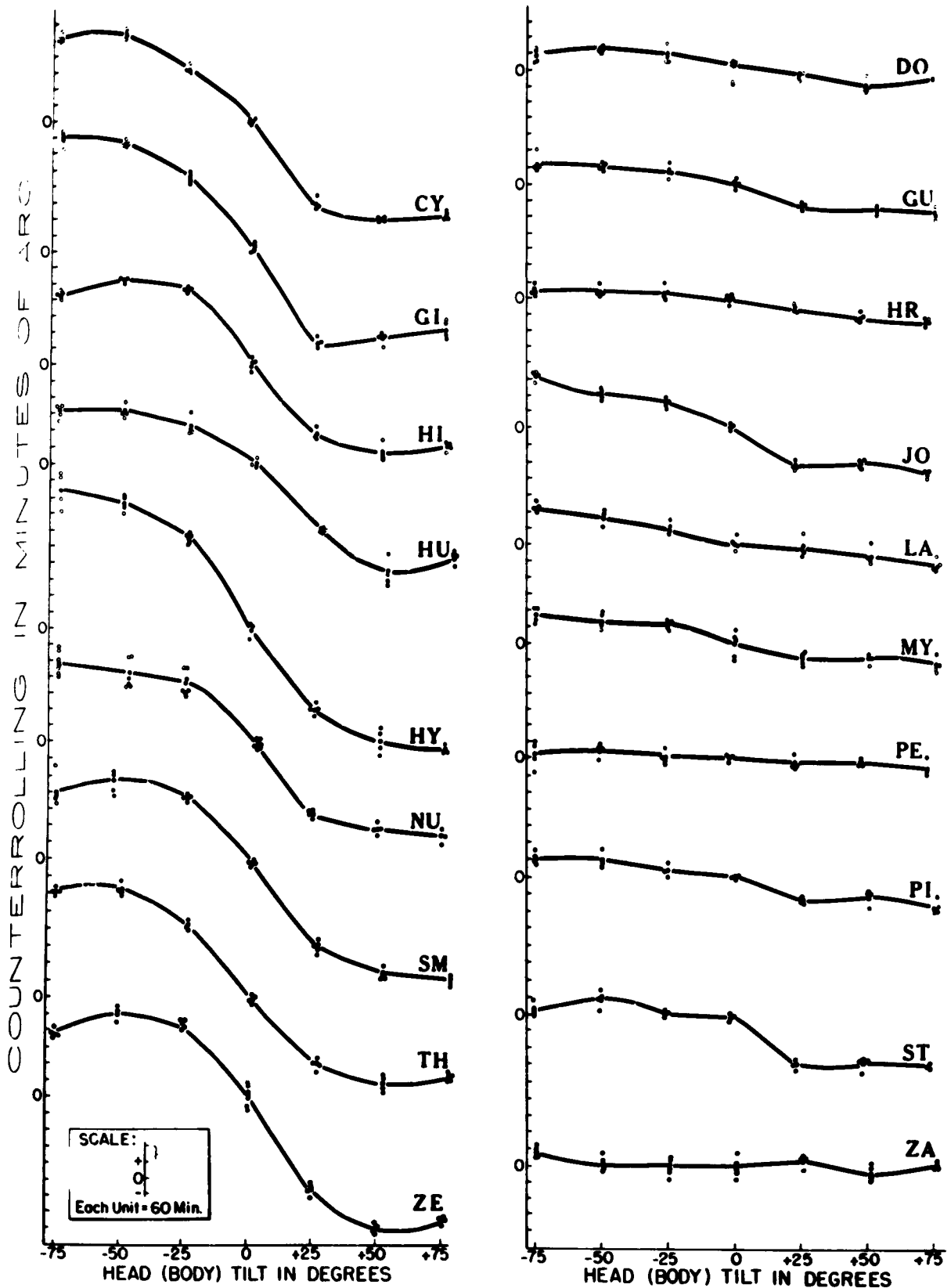

Figure 2  
 Mean Counterrolling Values Plotted as a Function of Leftward and Rightward Tilt  
 Left: Normals  
 Right: L-D Subjects  
 Closed Circles: Average Values in Minutes of Arc  
 Open Circles: Values for Different Trials at a Given Body Position

and greatest mean left torsion, ranged from 286 to 465 minutes of arc. With three exceptions, two leftward and one rightward, there was little interindividual variance in the curves of the normal subjects between  $-25^{\circ}$  and  $+25^{\circ}$ .

The values obtained for the L-D subjects did not overlap those for the normal. The nearest approach to overlapping values, using combined left-right values, was 286 minutes of arc in the case of a normal subject and 176 minutes of arc in the case of an L-D subject. There were no overlapping values even when rightward or leftward tilt was compared. In the L-D group the counterrolling index ranged from 30 to 176 minutes of arc. In two instances counterrolling was almost nil, in one it was limited to rightward tilt, and in others there was a small but nearly straight line relation between counterrolling and tilt (Figure 2, righthand column). The interindividual variance in absolute values was less than in the normal subjects but relative to the amount of counterrolling it is considerable.

## DISCUSSION

The reliability of the method used to measure counterrolling was good insofar as repeated measurements from the same photograph were concerned, but considerable variance was found in measurements obtained from several photographs taken for the same body position. The greater the counterroll for a given angle of tilt, the greater the reliability of the measurement; hence, greatest reliance was placed on the measurements obtained at 25 degrees and successively less at 50 and 75 degrees. Combining the measurements obtained on leftward and rightward tilt increased the reliability of counterrolling for two reasons; first, because the total roll was greater and second, because left-right differences were minimized, especially those in which right-left "symmetry" could be restored by shifting the "zero" or "neutral" position. For screening purposes and for most investigations involving comparative measurements of counterrolling it would suffice to measure the amount of counterrolling at 25 degrees rightward and leftward tilt. Here the signal-to-error ratio is most favorable, and fixation of the body and head is most easily accomplished. The addition of the two values, neglecting sign, could be used as a single value or index of counterrolling ratio of roll to tilt (CI).

The striking difference in the findings between the normal and L-D subjects must have been due to the loss of function of the sensory organs of the inner ear. There is no evidence that the counterrolling reflex is released by the organ of Corti and insufficient evidence that it originates in the semicircular canals (5) but good evidence that it is released by the otoliths in animals (6,7) and in man (8-10). It may be concluded that the reduction in counterrolling in the L-D subjects was the result of injury to the otoliths.

This still leaves for consideration the explanation for interindividual differences. In the L-D group they must be ascribed either to residual function of the otolith apparatus, to some other origin such as a "cervical reflex" (7,9,10), or to artifact. The last would be revealed either as an occasional or constant error, neither of which would explain the curves. With regard to the cervical reflex, we sought to avoid it by fixing the head relative to the thorax. That we succeeded or failed in a perfectly consistent manner is beyond the realm of possibility. Hence we were led to the conclusion that residual otolith function was the most probable explanation for "significant" amounts of roll. The difference between the extremes is distinct, but this leaves a middle group in which a demarkation is difficult.

## REFERENCES

1. Woellner, R.C., and Graybiel, A., A new and objective method for measuring ocular torsion. Amer. J. Ophthal., 47: 349-352, 1959.
2. Woellner, R. C., and Graybiel, A., Counterrolling of the eyes and its dependence on the magnitude of gravitational or inertial force acting laterally on the body. J. appl. Physiol., 14: 632-634, 1959.
3. Woellner, R. C., and Graybiel, A., The loss of counterrolling of the eyes in three persons presumably without functional otolith organs. Ann. Otol., etc., St. Louis, 69: 1006-1012, 1960.
4. Miller, E. F. II, Counterrolling of the human eyes produced by head tilt with respect to gravity. Acta otolaryng. Stockh., 54: 479-501, 1962.
5. Lorente de Nó., R., The regulation of eye position and movements induced by the labyrinth. Laryngoscope, St. Louis, 42: 233-332, 1932.
6. Wittmaack, K., Ueber Veränderungen im inneren Ohre nach Rotationen. Verh. dtsh. otol. Ges., 19: 150-156, 1909.
7. de Kleijn, A., and Magnus, R. Über die Funktion der Otolithen. II. Mitteilung. Isolierte Otolithenausschaltung bei Meerschweinchen. Pflug. Arch. ges. Physiol., 186: 61-81, 1921.
8. Barany, R., Über die vom Ohrlabyrinth ausgeloste Gegenrollung der Augen bei Normalhorenden, Ohrenkranken und Taubstummen. Arch. Ohr., Nas., u. KehlkHeilk., 68: 1-30, 1906.
9. Fischer, M. H., Messende Untersuchungen über die Gegenrollung der Augen und die Lokalisation der scheinbaren Vertikalen bei seitlicher Neigung des Körpers, Kopfes und Stammes. III. Mitteilung. v. Graefes Arch. Ophthal., 123: 509-531, 1930.
10. Kompajetz, S., On compensatory eye movements in deaf-mutes. Acta otolaryng., Stockh., 7: 323-334, 1925.