

UNCLASSIFIED

AD 296 071

*Reproduced
by the*

ARMED SERVICES TECHNICAL INFORMATION AGENCY
ARLINGTON HALL STATION
ARLINGTON 12, VIRGINIA



UNCLASSIFIED

NOTICE: When government or other drawings, specifications or other data are used for any purpose other than in connection with a definitely related government procurement operation, the U. S. Government thereby incurs no responsibility, nor any obligation whatsoever; and the fact that the Government may have formulated, furnished, or in any way supplied the said drawings, specifications, or other data is not to be regarded by implication or otherwise as in any manner licensing the holder or any other person or corporation, or conveying any rights or permission to manufacture, use or sell any patented invention that may in any way be related thereto.

63-2-4

296071

APGC-TDR-63-1

AS AD No. 296071



Active Radar Augmenter Evaluation

A Validated Mathematical Approach

by John F. Kantak, 1st Lt, USAF

APGC Technical Documentary Report No. APGC-TDR-63-1

JANUARY 1963 • APGC Project No. 7826W21

DEPUTY FOR AEROSPACE SYSTEMS TEST

AIR PROVING GROUND CENTER

AIR FORCE SYSTEMS COMMAND • UNITED STATES AIR FORCE

EGLIN AIR FORCE BASE, FLORIDA



Qualified requesters may obtain copies from ASTIA. Orders will be expedited if placed through the librarian or other person designated to request documents from ASTIA.

When US Government drawings, specifications, or other data are used for any purpose other than a definitely related government procurement operation, the government thereby incurs no responsibility nor any obligation whatsoever; and the fact that the government may have formulated, furnished, or in any way supplied the said drawings, specifications, or other data is not to be regarded by implication or otherwise, as in any manner licensing the holder or any other person or corporation, or conveying any rights or permission to manufacture, use, or sell any patented invention that may in any way be related thereto.

Do not return this copy. Retain or destroy.

Catalog cards may be found in the back of this document.

ABSTRACT

The purpose of this study was to establish a technique for determining the radar cross-sectional area of any active radar augmentor. This proposal suggests that mathematical calculations are sufficiently accurate to allow test personnel to base conclusions on the calculated values.

The theory and mathematics of the proposed technique were established, and an experiment was accomplished to obtain the accuracy of the computations. The overall accuracy of the method depended upon the accuracy of the computations plus the accuracy of the measuring instruments. Technique accuracy was found to be ± 1 db.

Since an accuracy has been established, this technique can be utilized by test personnel when evaluating active radar augmentors. A five-step procedure for evaluating an augmentor is presented.

PUBLICATION REVIEW

This technical documentary report has been reviewed and is approved.



A. T. CULBERTSON
Brigadier General, USAF
Vice Commander

CONTENTS

Section	Page
1. INTRODUCTION	1
2. BRIEF DISCUSSION OF ANTENNA THEORY	2
Isotropic Antennas	2
Directional Antennas	2
3. DEVELOPMENT OF RADAR RANGE EQUATION	3
4. DETERMINATION OF POWER RETURN	6
R-F Signal Transmission Path	6
Augmenter Considerations	8
R-F Signal Return Path	10
5. ANTENNA RANGE EXPERIMENT	13
Antenna Radiation Pattern	13
Accuracy Dependent Upon Calculation of Free-Space Attenuation	16
Transmission Path Computations and Measurements	17
Receive Path Computations and Measurements ..	18
Operational Calculations and Measurements	19
6. CONCLUSIONS	20
REFERENCES	22
Appendix	
DEVELOPMENT OF FREE-SPACE ATTENUATION FORMULA	23

ILLUSTRATIONS

Figure	Page
1. Block Diagram Model Showing Parameters	4
2. Block Diagram Model Showing R-F Trans- mitted Signal Path	7
3. Transponder Power Output Characteristic	9
4. Amplifier Power Output Characteristic	10
5. Mathematical Model of R-F Return Signal Path	11

ILLUSTRATIONS (Continued)

Figure		Page
6.	Decibel to Square Meter Conversion Graph	12
7.	Antenna Range Experiment Setup	14
8.	S-Band Quarter-Wave Stub Antenna Pattern	15
9.	S-Band Quarter-Wave Stub Antenna Pattern Mounted on TDU-9/B Tow Target	16
10.	Free-Space Attenuation vs. Range for a Constant Frequency	25

SECTION 1 - INTRODUCTION

Enhancing the radar signature of various aerospace vehicles by augmentation has enabled scientists and engineers to glean more data from the missions accomplished, has extended vehicle tracking volume, and has improved flying safety conditions by increasing the capabilities of ground control.

To date, the data collected on various active radar augmenters have been extremely difficult to analyze. A study of available literature indicates a deficiency of information concerning methods for evaluating active augmenters.

An evaluator should examine individual augmenters on the basis of the radar cross-sectional area (amount of radar signal returned) each augments presents to an interrogating radar. It is the intent of this paper to establish an accurate mathematical technique that will determine the radar cross-sectional area of any augments within the operational envelope of any applicable interrogating radar.

In general, mathematical analysis can never fully replace flight test evaluations of electronic equipment. Reaction to temperature, shock, and the functional ability of the augments must be checked in an operational environment. However, the ensuing technique should result in a reduction of test flights required for each augments from approximately 25 to 1 or 2, and will yield an ultimate saving in Air Force time, money, and resources.

To verify the accuracy of the mathematical analysis, an antenna range experiment was performed. Experimental and calculated data were compared, basing the validity of the mathematical analysis upon the experimental data used as a standard. Although the technique presented in this study is applicable to any frequency, the antenna range experiment was accomplished in the S-band frequency range.

The writer is grateful for the motivation provided by Mr. A. Guastaferrero, Mr. A. Davis, and Captain L. Lebanoff, USAF. Acknowledgement is given to the Aero Geo Astro Corporation for the S-band augments and antenna the corporation provided for the antenna range experiment.

SECTION 2 - BRIEF DISCUSSION OF ANTENNA THEORY

To establish a relationship between power transmitted from a directional antenna and power incident upon an intended target, a brief discussion of radar antenna theory is given in this section.

ISOTROPIC ANTENNAS

Generally, antenna theory is discussed in terms relative to a perfect antenna which radiates energy uniformly in all directions. The power incident upon any specified area on the surface of the radiation sphere can be determined from the transmitted power and the range to the designated area. The surface area of a sphere is equal to 4π times the radius squared. Radiated power decreases in intensity by the inverse square of the distance from the radiating source. Using these facts, the power incident upon the specified area is

$$P_i = P_t \frac{1}{4\pi R^2}$$

where: P_i = power incident
 P_t = power transmitted
 R = range.

DIRECTIONAL ANTENNAS

A directional antenna concentrates all the radiated energy in a specified direction. The transmitted power is affected by a factor called the gain of the directional antenna. The gain of an antenna either increases or does not appreciably affect the power transmitted from the antenna. Antenna gain is a function of the wavelength of the transmitted signal and the size of the antenna aperture. Another facet of a directional antenna is called the effective receiving cross-sectional area. This term denotes the power available, at the terminals of the antenna, from an incident signal--in other words, the portion of the signal waveform that is sampled by the receiving antenna. The effective receiving cross section is dependent upon the gain of the antenna and the wavelength of the received signal, as given by

$$A_r = \frac{G\lambda^2}{4\pi} \quad (1)$$

where: A_r = effective receiving cross section
 G = gain
 λ = wavelength of the transmitted signal.

When using a directional antenna, the power density on a specific area of the pattern is of interest. Similar to the spherical radiation pattern of the isotropic antenna, the directional antenna also radiates a three-dimensional pattern. The power is reduced by the inverse square of the range, and the target subtends $\frac{1}{4}\pi$ of the radiation volume. However, as stated before, the gain of a directional antenna affects the transmitted power. Therefore, at the position of the target on the surface of the radiation volume, the power density is equal to

$$\frac{P_t G_t}{4\pi R^2}, \text{ where } G_t \text{ is the transmitting antenna gain.} \quad (2)$$

The above described relationship may now be employed in deriving the needed radar cross-sectional area formula.

SECTION 3 - DEVELOPMENT OF RADAR RANGE EQUATION

Fig. 1 is a block diagram model showing the parameters required to develop a relationship between transmitted and received power at the interrogating radar. The incident power at the augments is determined by the power density of the transmitted waveform and the effective receiving cross-sectional area of the augments antenna, as

$$P_i = \text{Power Density} \times A_r.$$

Using (1), (2), and Fig. 1, we have

$$P_i = \frac{P_t G_t G_i \lambda^2}{(4\pi R)^2}. \quad (3)$$

For computation purposes, (3) can be rearranged to become a relationship defining the transmitted power in terms of the r-f transmission path and associated parameters, expressed as

$$P_t = \frac{P_i (4\pi R)^2}{G_t G_i \lambda^2}. \quad (4)$$

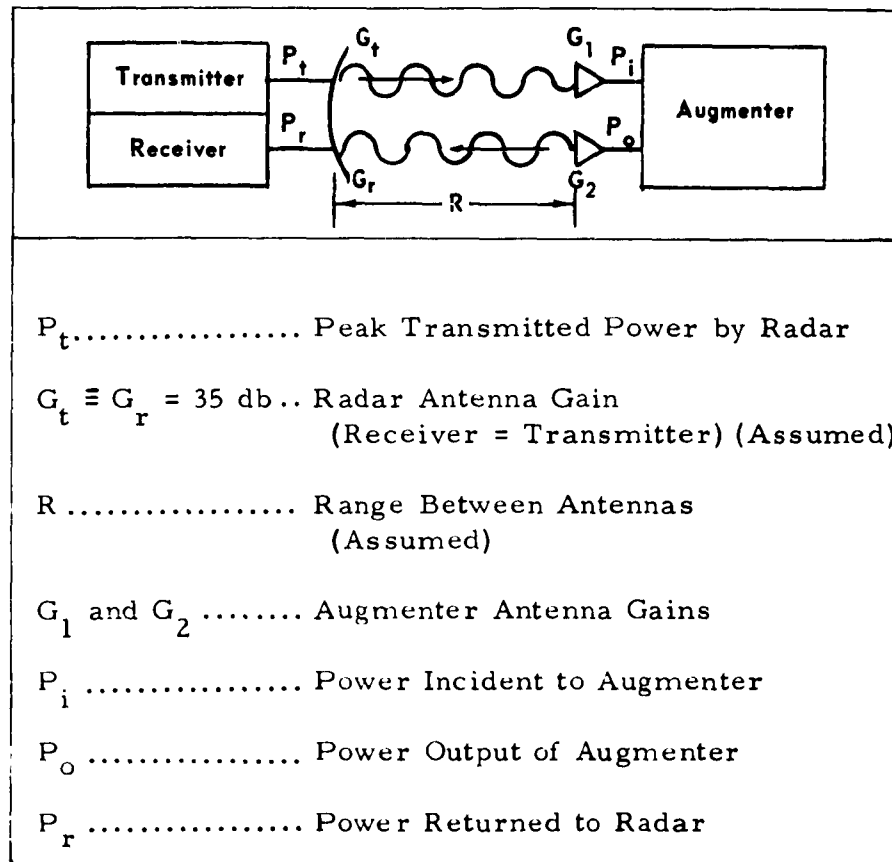

Fig. 1: Block Diagram Model Showing Parameters.

The power returned to the radar by the target is a function of the power density of the returned waveform and the effective receiving cross section of the interrogating radar antenna, expressed as

$$P_r = \frac{P_o G_r G_2 \lambda^2}{(4\pi R)^2} \cdot \tag{5}$$

To obtain a relationship between the power returned and the power transmitted from the interrogating radar, (5) is divided by (4). The resultant relationship is separated such that the last term defines the radar cross-sectional area (σ) of the target augmenter.

$$\frac{P_r}{P_t} = \frac{G_t G_r}{(4\pi)^3 R^4} \cdot \frac{G_1 G_2 \lambda^2 P_o}{4\pi P_i} \cdot \tag{6}$$

At this point it is pertinent to state that all values are measured at positions noted on Fig. 1. Thus, the following equalities are obvious:

$$\sigma = \frac{G_1 G_2 \lambda^2 P_o}{4\pi P_i}$$

$$G^2 = G_t G_r.$$

Using the above equalities and (6), the radar cross-sectional area of the target augmenter is obtained in terms of the transmitted power from and the returned power to the interrogating radar, expressed as follows in square meters [6]:*

$$\sigma = \frac{P_r (4\pi)^3 R^4}{P_t G^2 \lambda^2}. \quad (7)$$

The transmitted power in (7) is peak power. Future use of the final relationship dictates the use of decibels in describing radar cross-sectional area. The change in units requires that range be stated in meters. However, range is more available in nautical miles (nm) so the two will be correlated.

$$\text{Nautical miles} \times 1.85 \times 10^3 = \text{meters}$$

$$10 \log R^4 = 10 \log (1.85)^4 + 10 \log (R)^4 + 10 \log (10^3)^4$$

$$40 \log R = 40 \log (R^1) + 120.27$$

where R^1 is in nautical miles.

Converting (7) to decibel form and inserting the two previously developed relationships, an equation for the target augmenter radar cross-sectional area in decibels is obtained.

$$\sigma = P_r + 30 \log 4\pi + 40 \log R^1 - P_t - 2G - 20 \log \lambda + 120.27. \quad (8)$$

Reducing (8) to the fewest number of unknowns, the 4π , gain, and wavelength terms must be calculated.

* Numbers in brackets refer to literature references.

$$30 \log 4\pi = 32.97$$

$$2G = 70$$

$$20 \log \lambda = 20 \log \frac{300}{f} = 49.54 - 20 \log f$$

where f is the frequency in megacycles (Mc).

Combining all known quantities and simplifying (8) yields the radar cross-sectional area of the augmenter in simple form.

$$\sigma = P_r + 40 \log R^1 - P_t + 33.70 + 20 \log f. \quad (9)$$

Equation (9) defines the radar cross-sectional area of the augmenter presented to the interrogating radar. The transmitted power, frequency, and range are readily available at the interrogating radar. However, it has been physically impossible to measure the returned power from the augmenter with the present resources available at APGC. Thus, another method must be devised to obtain this unknown parameter.

SECTION 4 - DETERMINATION OF POWER RETURN

R-F SIGNAL TRANSMISSION PATH

Fig. 2 illustrates the r-f signal transmission path from the interrogating radar to the target augmenter. As previously stated, the gain of a directional antenna affects the power transmitted from it. From the assumed values for parameters in Fig. 2, the power index of the antenna is obtained.

$$\text{Power Index} = P_t + G_t = 90 + 35 = 125. \quad (10)$$

The power index is no more than a measure of the resultant transmitted power from a specific radar system. However, the power index of the radar is not the incident power at the augmenter antenna. The signal undergoes free-space attenuation as it traverses the distance between the radar and the target augmenter. Free-space attenuation (a_n) is dependent upon the range and the frequency of the transmitted signal.*

* See the appendix for development of the free-space attenuation formula and graph.

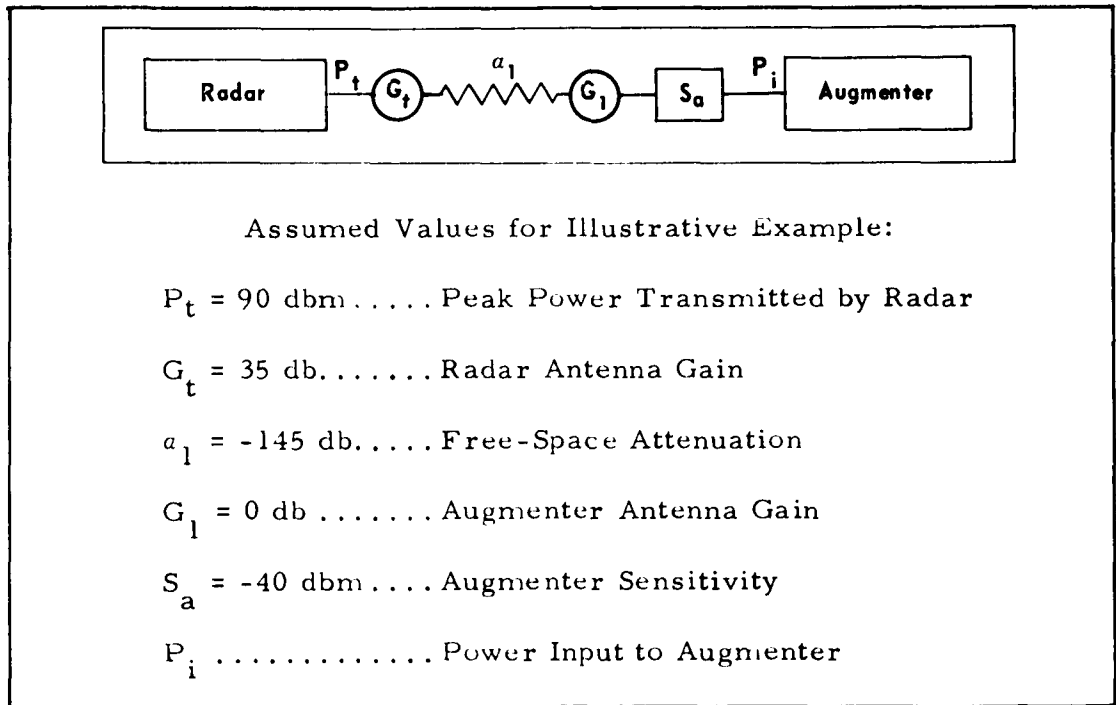

Fig. 2: Block Diagram Model Showing R-F Transmitted Signal Path.

Thus, the incident power at the augmenter antenna is equal to the algebraic summation of the power index and the free-space attenuation.

$$\text{Incident Power} = \text{Power Index} + a_1 = 125 - 145 = -20. \quad (11)$$

Since the assumed gain of the augmenter antenna in decibels is zero, the incident power is the power input to the augmenter, and is equal to -20.

One of the most important considerations at this point is the sensitivity of the augmenter. Augmenter sensitivity is simply the minimum power required to initiate operation of the augmenter. In other words, if the input power is less than the sensitivity level (S_a) the augmenter won't function. The inequality can be solved by obtaining the algebraic difference of the input power and the augmenter sensitivity. In this example, the input power is sufficient to initiate the augmenter operation.

$$\text{Incident Power} - S_a = -20 + 40 = 20 \quad (12)$$

It has now been established that the augments will function at the range involved in this example. To complete the computation of the power returned to the radar, the output power and concept of operation must be considered. There are two major methodologies prevalent at this time. One concept obtains augmentation by using transponders, and the other concept achieves the same goal by using amplifiers. Each method must be considered separately because each type of augments has a different output power characteristic. The output characteristic of an augments is an important part in the calculation of the power returned to the interrogating radar.

AUGMENTS CONSIDERATIONS

Investigating first the output power characteristic of the transponder depicted in Fig. 3, it is readily seen that a transponder has a predetermined output power. In other words, if there is sufficient energy presented to the augments by the interrogating radar to initiate the operation of the augments, the augments power output will be a constant value. Thus, in determining the power returned from this type of augments, it must first be established that the augments will function on the amount of energy it receives from the interrogating radar at the range involved. Then, knowing that the augments has a constant output power, the computations involved in the return r-f signal transmission path can be accomplished. If the power returned by the augments to the interrogating radar is of sufficient intensity to be seen by the radar, the radar cross-sectional area of the augments may be determined.

The amplifier method of augmentation does not have constant output power. Fig. 4 indicates that the general output of the amplifier is dependent upon the input energy. A traveling wave tube (TWT) is an example of an amplifier-type augments. The TWT is essentially a wide-band microwave amplifier with an adjustable gain control for a definite range of input signals. Amplification is attained through velocity modulation of an electron beam focused along the center axis of a helix. The input signal is coupled onto the helix, and the helix signal bunches the electrons of the focused electron beam. The bunched electrons reinforce the signal on the helix. This process continues throughout the length of the TWT. The amount of gain, and directly related output power, that may be obtained from a TWT is limited by the saturation point of the helix. The saturation point of the TWT (helix) is dependent upon the effect of temperature on the physical structure and form of the helix. A variance in pitch or curvature in the physical shape and form of the helix, as minute a change as one micron, limits the amount of power that can be obtained from the TWT.

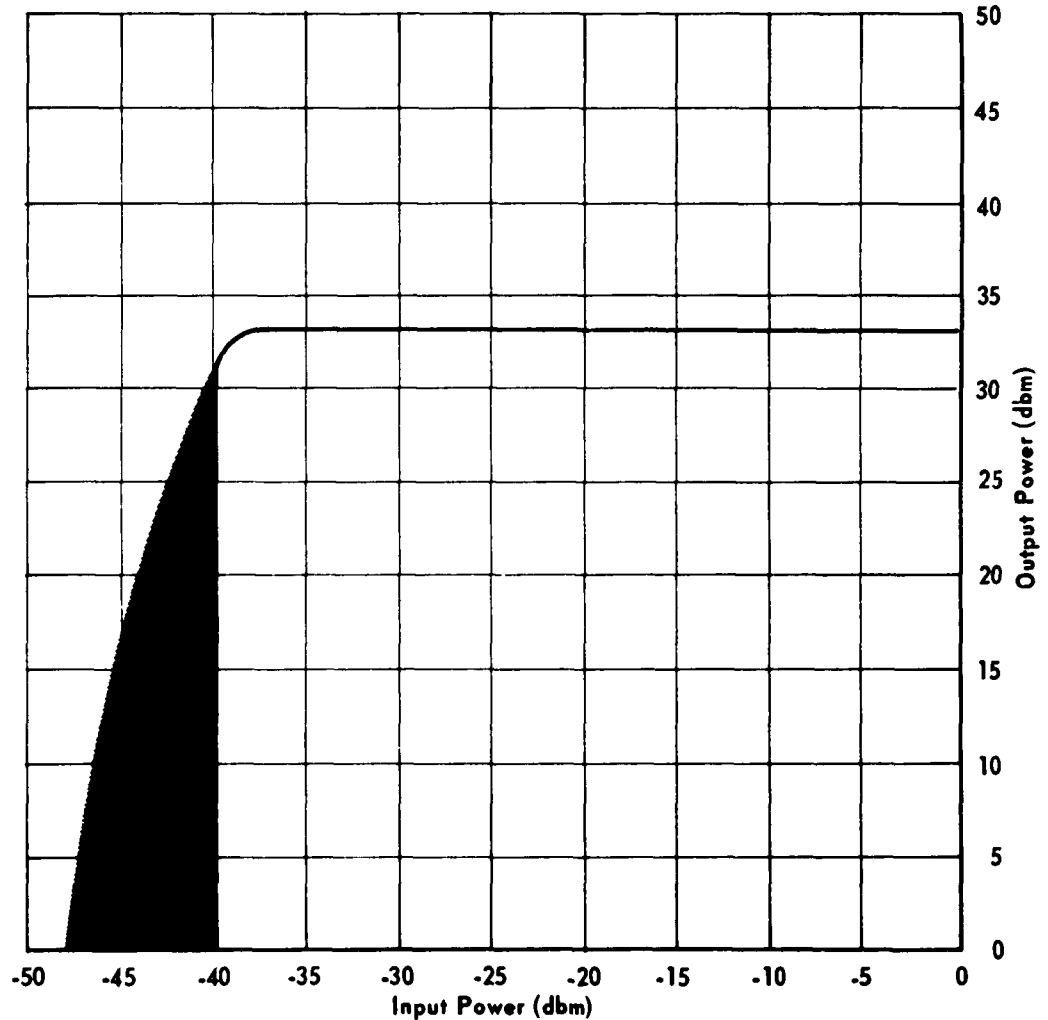

Fig. 3: Transponder Power Output Characteristic.

Therefore, the power output must be obtained from a characteristic power graph when determining the power returned to the radar by the augmentor. The characteristic power curve will vary for each augmentor, so care must be exercised when utilizing a power graph. However, after the power output of the augmentor is determined, the mathematical computations involved in assessing the power returned to the radar may be readily employed.

The output power for this example will be considered as that of a transponder with a constant two-watt output independent of the input power. A mathematical model of the return r-f transmission path is

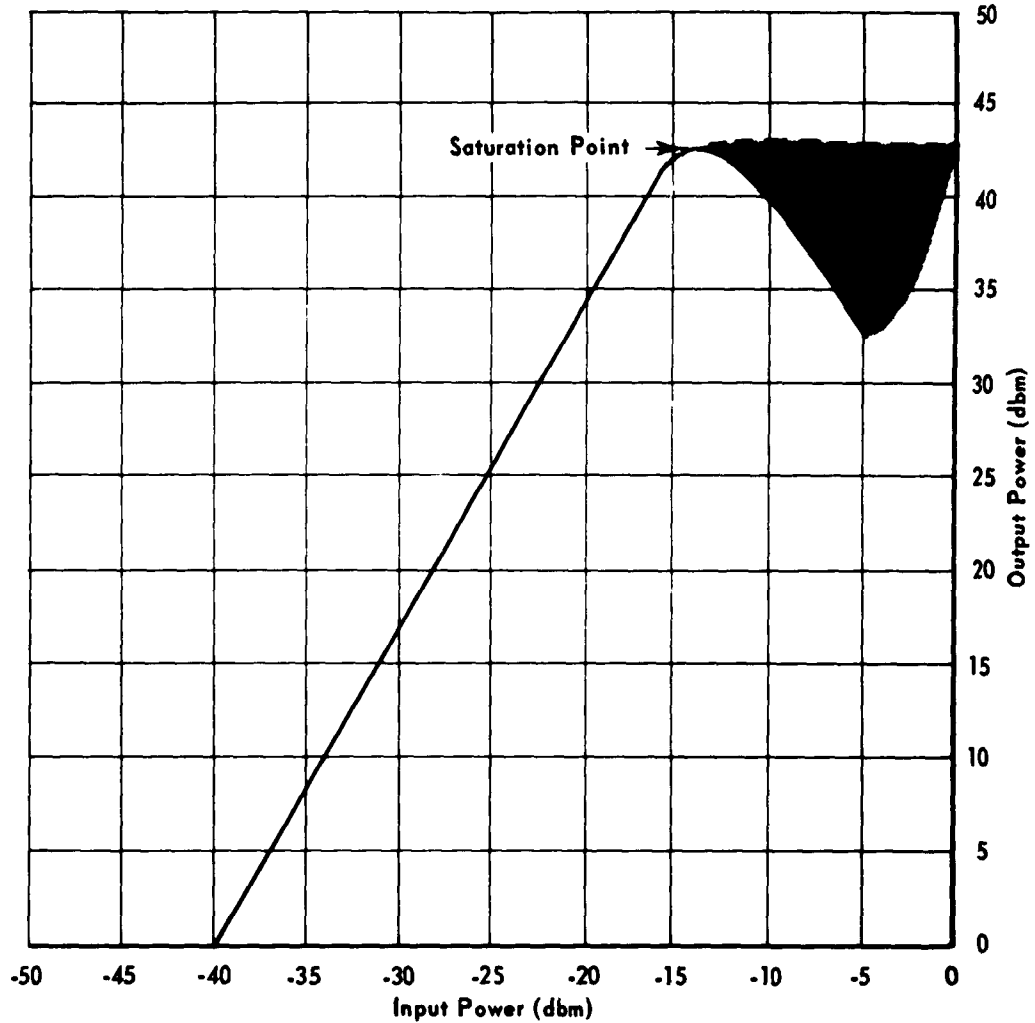

Fig. 4: Amplifier Power Output Characteristic.

shown in Fig. 5. Having defined the parameters of the return r-f path, the same computations accomplished on the transmission path will be redone.

R-F SIGNAL RETURN PATH

The power index of the augments is equal to the output power because of the idealized augments antenna ($G = 0$). Thus, the power incident upon the interrogating radar is the augments output power decreased by the free-space attenuation.

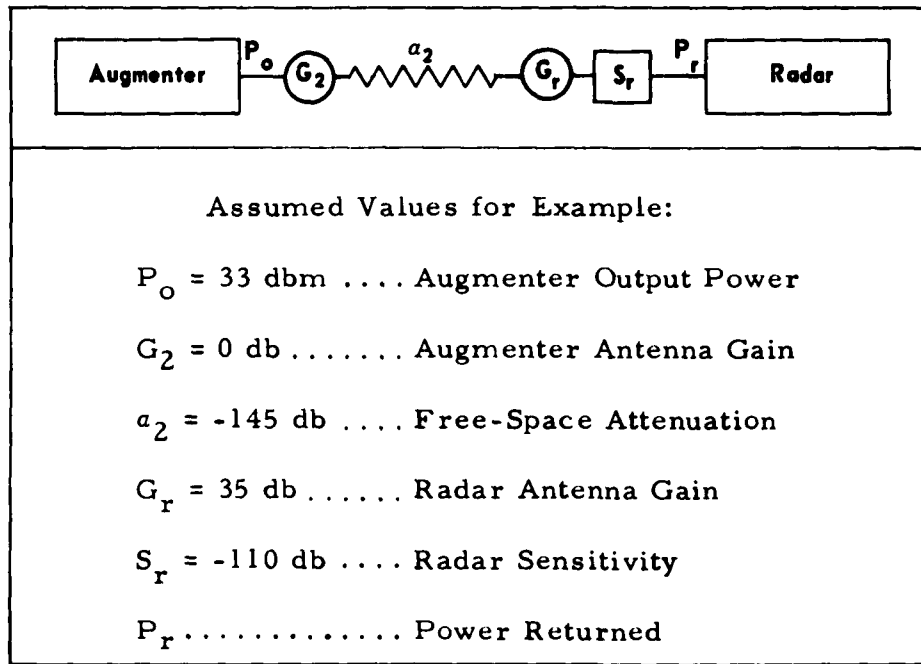

Fig. 5: Mathematical Model of R-F Return Signal Path.

$$\text{Incident Power} = P_o + a_2 = 33 - 145 = -112. \tag{13}$$

The primary object of the above computations has been to obtain the power returned to the interrogating radar so that (9) may be computed. Knowing the incident power at the radar, the antenna effect is algebraically added to yield the power returned.

$$\text{Power Returned} = \text{Incident Power} + G_r = -112 + 35 = -77. \tag{14}$$

This value may be substituted in (9) to obtain the radar cross-sectional area of the target augmenter. After obtaining σ in decibels, conversion from decibels to square meters may be accomplished from Fig. 6. However, the power returned must be great enough to be "seen" by the interrogating radar. In other words, the power returned to the radar must be greater than the sensitivity of the radar.

The algebraic difference of the power returned and the radar sensitivity will determine if the augmenter output is sufficient at the range being considered.

$$\text{Power Returned} - S_r = -77 + 110 = 33. \tag{15}$$

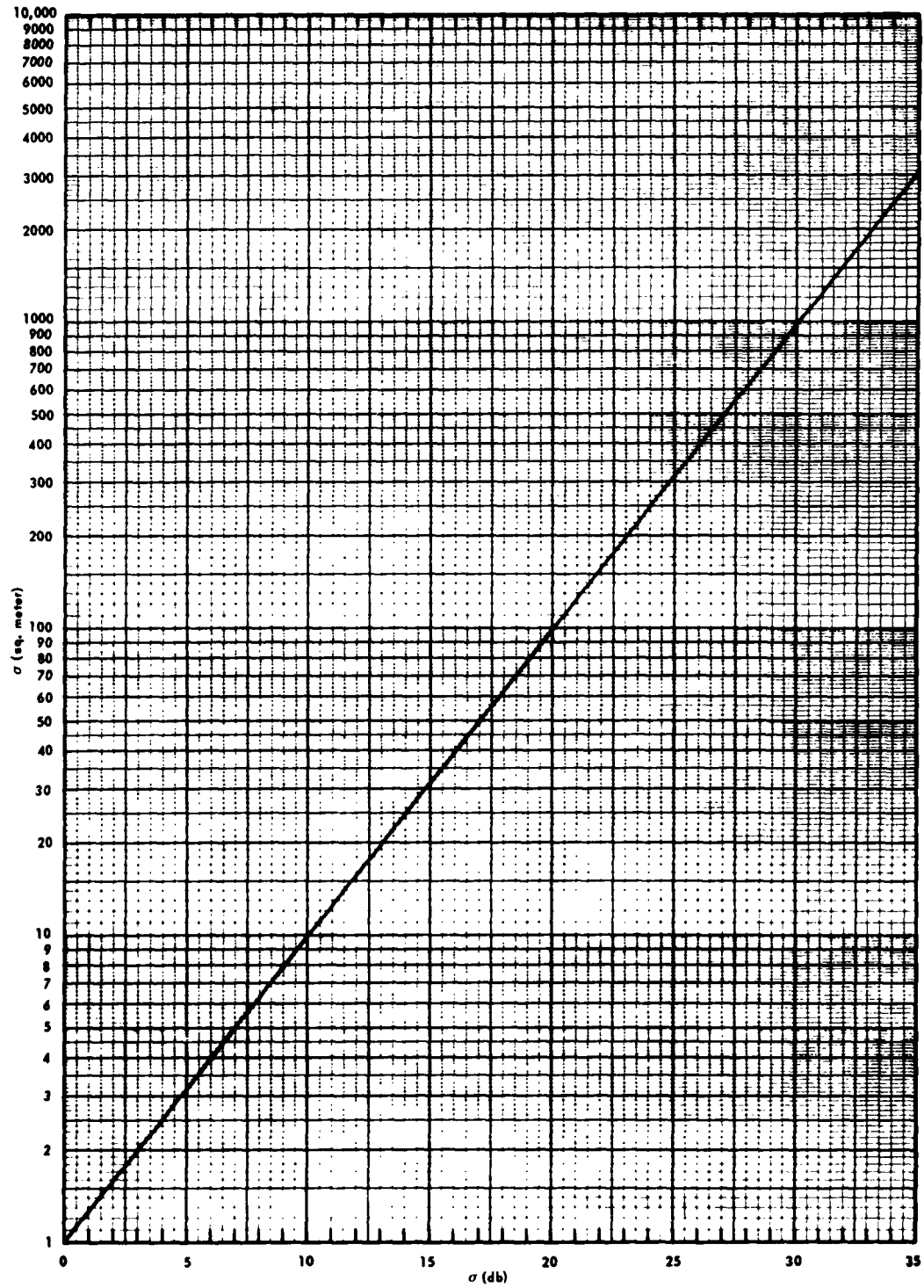

Fig. 6: Decibel to Square Meter Conversion Graph.

Thus by (15) the augmeter will be seen by the interrogating radar at the range being used in this example and yield the radar cross-sectional area determined by (9).

Computations, similar to the ones accomplished in this example, may be utilized with changes in the variables to accommodate this method to any practical problem. The aspect of the target augmeter to the interrogating radar was not considered during the discussion of this example. Aspect angle will determine the amount of augmeter output power that will be seen by the interrogating radar by virtue of looking into different portions of the augmeter antenna pattern. Zero degree azimuth and elevation were used in this report for simplification and brevity. However, it is readily seen that modifications to the mathematical computations can easily be accomplished to fit this analysis to any practical problem involving any frequency band and at any look angle to the target augmeter.

SECTION 5 - ANTENNA RANGE EXPERIMENT

To ascertain the validity and accuracy of the proposed analysis, an antenna range experiment was accomplished. The range setup is shown in Fig. 7. The augmeter and antenna were placed in a simulated operational situation, and data were collected for comparison with calculated values. To indicate the frequency independence of the proposed technique, an S-band augmeter and antenna were utilized in lieu of their L-band counterparts.

The simulated radar consisted of two 17.5-db gain S-band horn antennas placed 26 ft above ground level and transmission and receiving equipment. The augmeter S-band quarter-wave antenna was placed approximately 70 ft away from the simulated radar and 25 ft above ground level. The S-band crystal video augmeter operated on 28 vdc at a frequency of 2800 Mc, with a receiver sensitivity of -40 dbm, and an output of 35.85 dbm.

ANTENNA RADIATION PATTERN

Prior to completing the experiment, the antenna pattern of the augmeter antenna had to be determined. By transmitting a known power into the augmeter antenna and plotting the reaction of the antenna on a

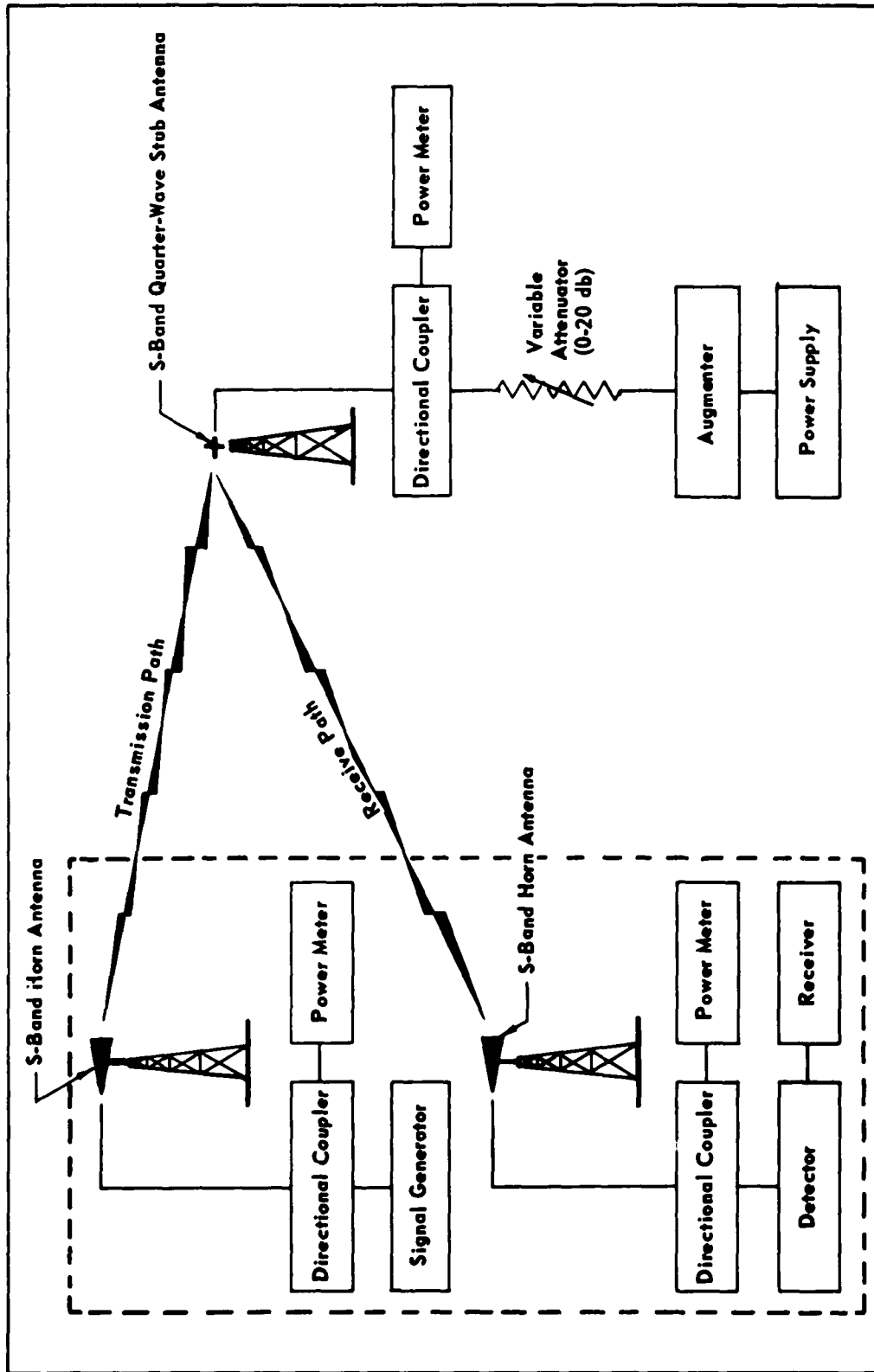

Fig. 7: Antenna Range Experiment Setup.

polar recorder, the augments antenna pattern was established (Fig. 8). The antenna pattern was established with the augments antenna alone, not attached to the tow target with which it will be utilized. This was done for expediency, since equipment would have had to have been constructed to accommodate the tow target at that time. However, an antenna pattern with the same antenna installed on a TDU-9/B tow target had been established previously (Fig. 9). The tow target and augments antenna pattern are included here to prove that the antenna pattern is of prime interest when utilizing the proposed technique.

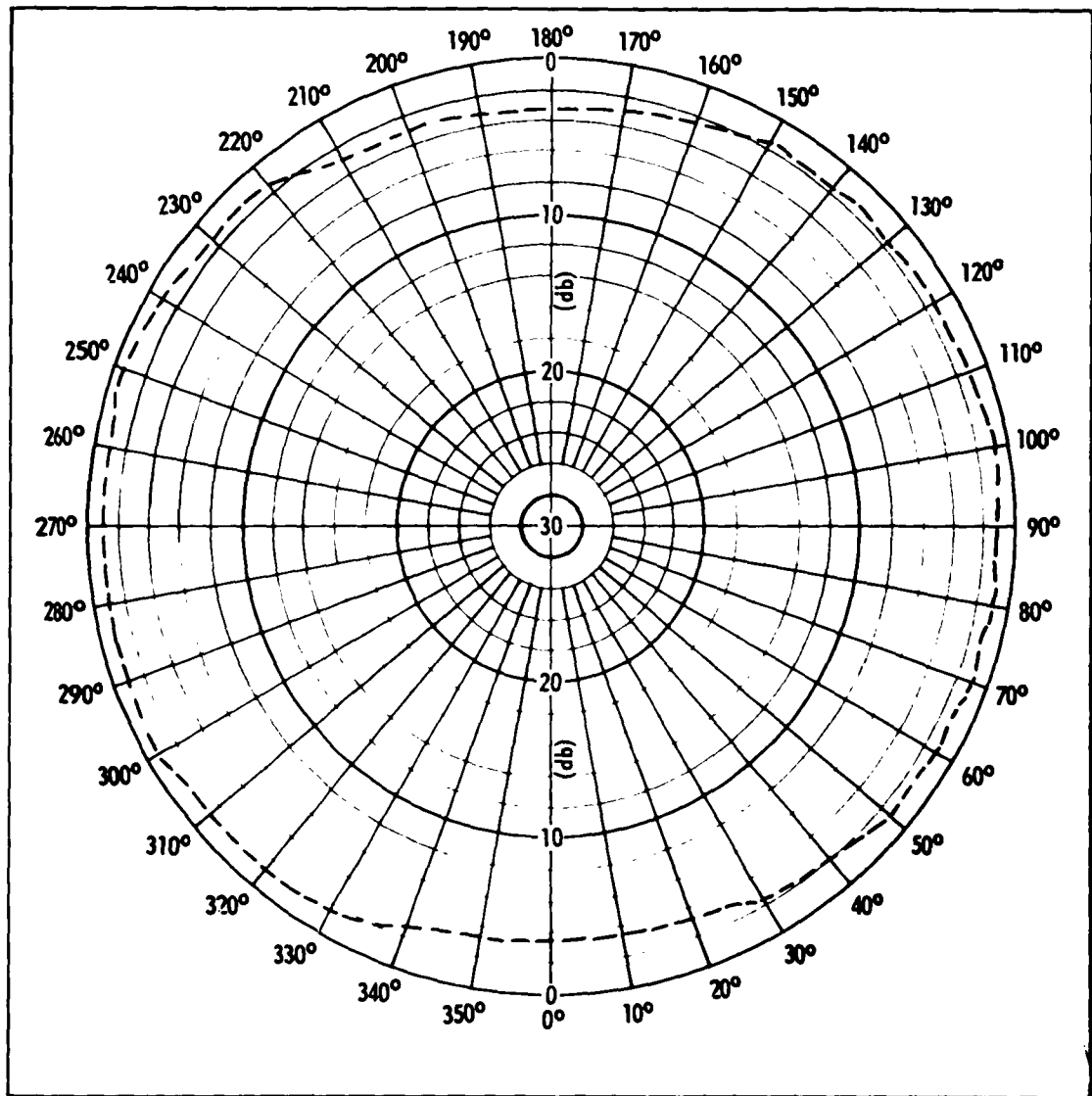

Fig. 8: S-Band Quarter-Wave Stub Antenna Pattern.

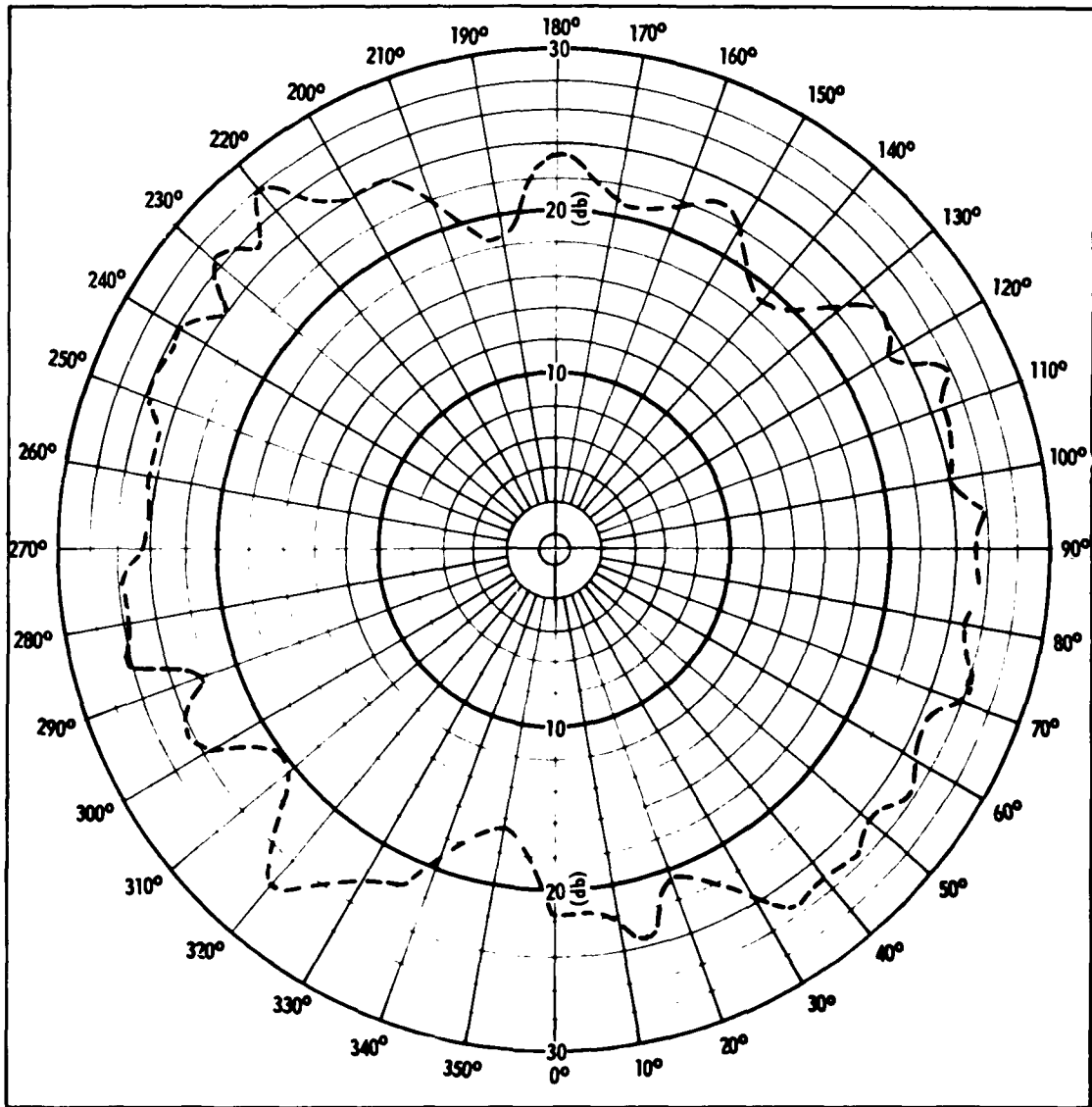

Fig. 9: Antenna Pattern - S-Band Quarter-Wave Stub Antenna Mounted on TDU-9/B Tow Target.

ACCURACY DEPENDENT UPON CALCULATION OF FREE-SPACE ATTENUATION

After reviewing the mathematics of the proposed technique, it is noted that there is only one unknown, free-space attenuation. Thus, the accuracy of this method is completely dependent upon the ability of the method to accurately determine the free-space attenuation.

TRANSMISSION PATH COMPUTATIONS AND MEASUREMENTS

The first part of the experiment was accomplished to determine the free-space attenuation of the transmission path from the simulated radar to the augmenter. The range of the transmission path was measured to be 69 ft, 11 in. Converted to nautical miles the range was 1.15×10^{-2} nm. Since the frequency was known and the range was measured, the free-space attenuation (a_{tc}) could be calculated, as follows

$$\begin{aligned} a_{tc} &= 37.79 + 20 \log f + 20 \log R \\ &= 37.79 + 20 \log 2.8 + 20 \log 10^3 + 20 \log 1.15 + 20 \log 10^{-2} \\ &= 37.79 + 8.943 + 1.214 - 40 + 60 \end{aligned}$$

$$a_{tc} = 67.95 \text{ db.}$$

The calculated attenuation was verified. Knowing the total power transmitted, the effect of the antennas, and the power received by the augmenter antenna, the attenuation of the transmission path was found as follows:

Transmitted power	8.9 dbm
Transmitter antenna gain	17.5 db
Augmenter antenna gain	<u>1.2 db</u>
Total power available	27.6 dbm
Power received at augmenter antenna	<u>-40.19 dbm</u>
Measured free-space attenuation (a_{tm})	67.79 db

Now the measured and calculated values can be compared to establish the calculated free-space attenuation accuracy.

$$a_{tc} - a_{tm} = \text{difference}$$

$$67.95 \text{ db} - 67.79 \text{ db} = 0.16 \text{ db}$$

$$\% \text{ difference } a_{tc} > a_{tm}$$

$$\frac{0.16}{67.79} \times 100 = 0.24\%$$

Thus, the error of calculation is 24/100 of 1%. However, the accuracy of the measuring instruments is $\pm \frac{1}{2}$ db, so that the accuracy of the calculation becomes ± 1 db.

RECEIVE PATH COMPUTATIONS AND MEASUREMENTS

The range for this portion of the experiment remained the same. Thus, the calculated free-space attenuation (a_{rc}) remained the same.

Utilizing the same method used on the transmission path, the free-space attenuation was derived. A known power was put into the augmenter antenna, and the power was measured at the terminals of the receiving antenna.

Transmitted power	20.0 dbm
Augmenter antenna gain	1.2 db
Receiver antenna gain	17.5 db
Total power available	<u>38.7 dbm</u>
Received power	<u>-29.5 dbm</u>
Measured free-space attenuation (a_{rm})	68.2 db

Now the calculated and measured values can be compared to establish the accuracy of the calculated free-space attenuation.

$a_{rc} < a_{rm}$ by difference

$$67.95 \text{ db} - 68.2 \text{ db} = -0.25 \text{ db}$$

% difference $a_{rc} < a_{rm}$

$$\frac{0.25}{68.20} \times 100 = 0.37\%$$

Thus, the error of calculation is 37/100 of 1%.

Since the accuracy of the measuring instruments is $\pm \frac{1}{2}$ db, the accuracy of the method becomes ± 1 db.

When comparing the two measured values of attenuation for the same range, a difference is found between the two values. Ground reflections account for the differences. Each signal path is different and has individual values for each signal path for free-space attenuation.

OPERATIONAL CALCULATIONS AND MEASUREMENTS

The augmenter was attached to the antenna and interrogated by the simulated radar. Additional attenuation was inserted in the path to reduce the available power to a level close to sensitivity of the augmenter to determine power at the augmenter. Values are listed below.

Transmitted power	30.0 dbm
Transmitter antenna gain	17.5 db
Augmenter antenna gain	<u>1.2 db</u>
Total power available	48.7 dbm
Free-space attenuation (a_{tc})	-67.95 db
Inserted attenuation	<u>-20.00 db</u>
Power at augmenter	-39.25 dbm

Thus, the augmenter should have enough power to initiate operation. Since the augmenter should function, it would have a power output of 35.85 dbm. Values to determine power at receiver are:

Augmenter power output	35.85 dbm
Augmenter antenna gain	1.20 db
Receiving antenna gain	<u>17.50 db</u>
Total available power	54.55 dbm
Free-space attenuation	-67.95 db
Inserted attenuation	<u>-20.00 db</u>
Power at receiver	-33.40 dbm

The inserted attenuation allowed the simulation of a larger range between antennas by decreasing the available power to the augmenter and receiver. The simulated range was 8.85 nm. When the augmenter was physically interrogated by the simulated radar, different power readings than were calculated were obtained. Using the same process previously utilized to find a from power readings, the calculated accuracy of the free-space attenuation was found.

Transmission Path:

Power at augmenter	-39.10 dbm
Transmission path attenuation	-87.80 db
Accuracy of attenuation calculation	0.17%

Receive Path:

Power at receiver	-33.65 dbm
Receiver path attenuation	-88.20 db
Accuracy of attenuation calculation	0.28%

Thus, the overall accuracies involved in employing this method can be stated to be ± 1 db. This accuracy allows test personnel to utilize this method of analysis at any frequency when evaluating active radar augmenters.

SECTION 6 - CONCLUSIONS

There is one principal unknown in the problem of defining the radar cross-sectional area of any airborne vehicle, the free-space attenuation (a). Thus, the accuracy of the technique discussed in this report depended upon the accuracy of the computation of a .

In three separate instances during the antenna range experiment the measured and calculated free-space attenuation were different by approximately 1/4 to 2/5 db. The accuracy of the instrumentation utilized to accomplish the physical measurements during the experiment was $\pm \frac{1}{2}$ db. Thus, the overall accuracy that can be assigned to the calculation of a is ± 1 db.

Since a is never mathematically amplified, the error of the original measurement remains the same for every application (13). The calculation of the power returned (14), therefore, carries the same accuracy that is assigned to the computation of a , i. e., ± 1 db. In the same manner, the power returned is never mathematically amplified (9). Thus the accuracy of this technique is ± 1 db.

The objective of this study, to establish an accurate mathematical technique to provide a numerical analysis of various active radar augmenters, has been accomplished. The accuracy is sufficient to allow use of the technique in Air Force evaluations.

The following proposed five-step method can be used when evaluating an augmenter.

1. Bench Check: Determine the sensitivity and power output of the augmenter in a laboratory. Combining these results with the power and gain characteristics of the equipment provides the necessary information required for the successful application of the technique described in this report.

2. **Environmental Test:** Perform a temperature check in accordance with military specifications. Using a strato-chamber to simulate required operational altitude and temperature, monitor the frequency and power output of the augmenter. The values obtained should very closely match the values obtained in the laboratory.

3. **Antenna Pattern:** Determine the pattern of the antenna by placing the augmenter antenna on the vehicle to be augmented.

4. **Radar Cross-Sectional Area:** If the data from steps one and two above establish that the augmenter is functioning correctly, the technique established in this report can be utilized to determine the radar cross-sectional area of the augmented vehicle anywhere within the operational envelope of an interrogating radar.

5. **Flight Test:** Accomplish one or two flight tests to ensure operation of the augmenters.

REFERENCES

1. AF Manual 52-8, Radar Circuit Analysis, p 10-29, 20 Jun 51.
2. WADD-TN-61-102, A Study of Target Augmentation Devices, Mar 61, Confidential Report.
3. Stavid Division of Lockheed Electronics Company, Case No. Q-0-178, Apr 60, Proposal for Active Radar L-Band Augmenter.
4. International Telephone and Telegraph Corporation, Handbook for Radio Engineers, 4th Ed.
5. Radiation Laboratories, Massachusetts Institute of Technology, Microwave Receivers, vol 23, p 560.
6. Radiation Laboratories, Massachusetts Institute of Technology, Radar System Engineering, vol 1, p 18-22.
7. Aero Geo Astro Corporation, Florida Division, Proposal for P. R. ASQT 63-206.

APPENDIX

DEVELOPMENT OF FREE-SPACE ATTENUATION FORMULA

The following facts are utilized to develop a relationship that will define the free-space attenuation (a_n) in terms of the frequency of the transmitted signal and the range between the two antennas being used.

1. Free-space path attenuation is given by:

$$a_n = 10 \log \left(\frac{P_t}{P_r} \right).$$

2. Transmitted power is given in terms of power received by target:

$$\frac{P_t}{P_r} = \frac{(4\pi R)^2}{G_t G_r \lambda^2}.$$

3. Wavelength in feet is given in terms of frequency and the speed of light (c):

$$\lambda = \frac{c}{f} = \frac{984}{f}.$$

4. Nautical mile = 6076 ft.

5. Substituting the relationship for the ratio of transmitted power to received power established in par. 2 above into the relationship for free-space path attenuation yields the following equality:

$$a_n = 10 \log \frac{(4\pi)^2 R^2}{G_t G_r \lambda^2} \text{ (db)}.$$

6. To obtain the free-space attenuation in terms of frequency and range, the wavelength must be converted to equivalent form using the relationship shown in par. 3 above. At the same time the range will be changed from miles to feet to keep continuity of units.

$$a_n = 10 \log \frac{(12.56)^2 (6076)^2 R^2 f^2}{(9.84)^2 (10)^4 G_t G_r} \text{ (db)}.$$

where: R is in nautical miles; f is in megacycles.

7. Expanding the relationship in par. 6 above by accomplishing the indicated logarithmic calculation, we have

$$a_n = 10 \log R^2 + 10 \log f^2 + 10 \log (12.56)^2 + 10 \log (6.076)^2 + \\ 10 \log 10^6 - 10 \log (9.84)^2 - 10 \log 10^4 - 10 \log G_t - \\ 10 \log G_r.$$

8. Since the equation in par. 1 is based on the use of isotropic antennas, the antenna gains G_t and G_r are unity. Thus, the two gain terms become zero and drop out of the equation. Computing the logarithms and solving the relationship, an equation for the free-space attenuation in terms of frequency and range is obtained.

$$a_n = 20 \log R + 20 \log f + 21.98 + 15.67 + 60 - 19.86 - 40 \\ a_n = 37.79 + 20 \log R + 20 \log f.$$

Fig. 10 was accomplished from this equality for a constant frequency of 1300 Mc. For practical use with nonisotropic antennas, the gain terms would not drop out of the equation in par. 7 and would have to be considered.

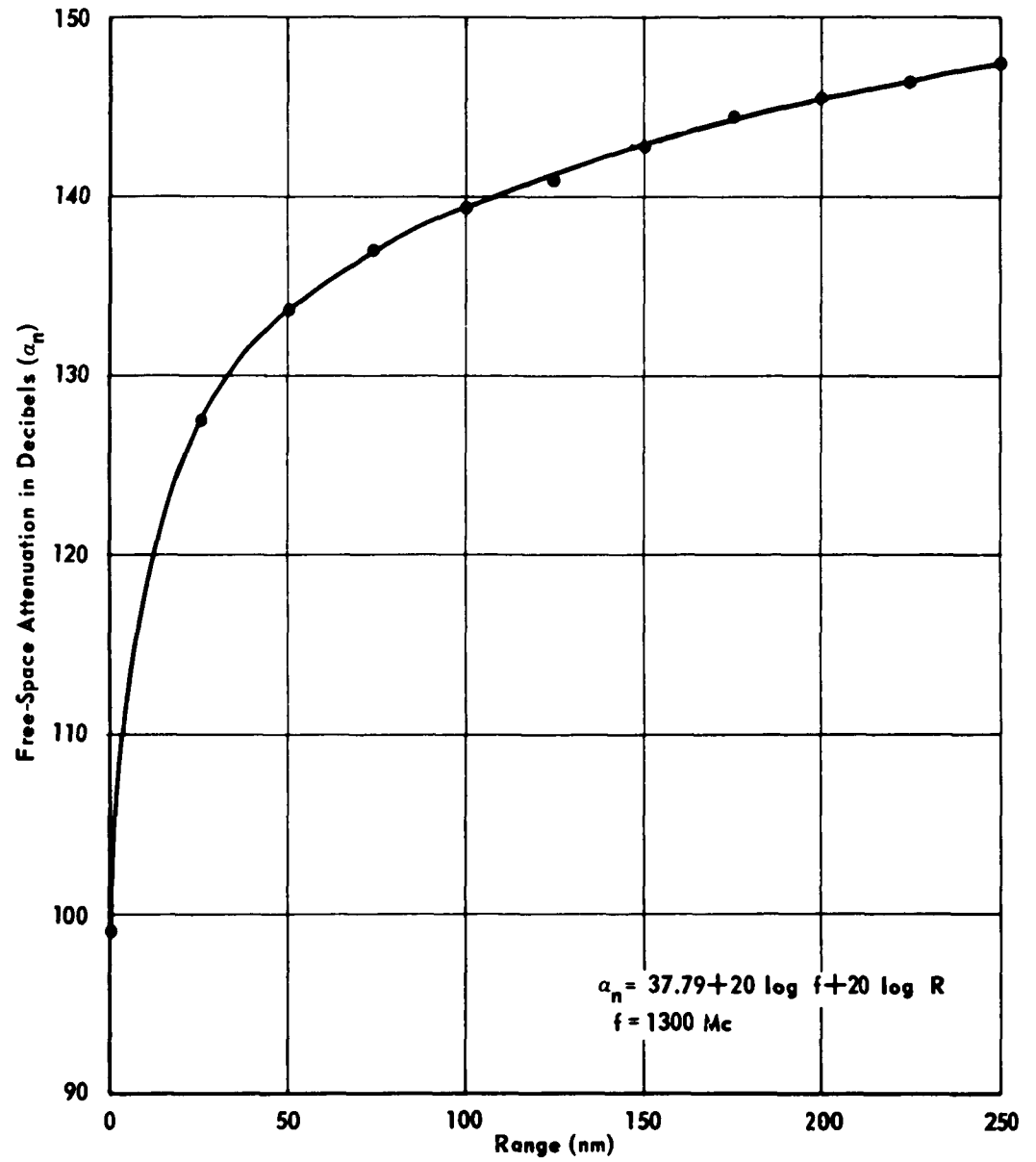

Fig. 10: Free-Space Attenuation vs. Range for a Constant Frequency.

INITIAL DISTRIBUTION

1 Wpns Sys Eval Gp
1 Hq USAF (AFDRT-GW)
1 Hq USAF (AFORQ-OT)
2 AFSC (SCPTP)
1 AFSC (SCSA)
1 5AF (5FCAG-P)
1 5AF((5FOPR-RQ)
1 13 AF (13ODO)
1 SAC (DM4A)
2 TAC (TPL-RQD)
1 BSD (Tech Lib)
1 AAC (XPR)
1 ADC (MME)
6 ASD (ASZT)
3 ASD (ASAD-Lib)
1 ASD (ASAT-Index)
3 AUL (9764)
2 AAC (ACS/Intelligence)
1 USAFE (DCS/Ops)(OTREQ)
1 AFMTC (AFMTC Tech Lib/MU-135)
1 4750 Test Sq (T&AE)
1 WS Missile Range (ORDBS-IRM-RID)
1 AFMDC (Tech Lib)
2 Tech Into Sec (Ord Corps)
1 RADC (Tech Lib)
3 Fleet Marine Force, Atlantic
1 USNADC
2 Redstone Scientific Info Center
14 USAF Academy
15 ASTIA (TIPCR)
APGC
13 PGWQ
2 PGAPI
3 PGEH
3 PGGT
10 ASQTS

<p>Air Proving Ground Center, Eglin Air Force Base, Florida Rpt No. APGC-TDR-63-1. ACTIVE RADAR AUGMENTER EVALUATION. A Validated Mathematical Approach. Final report, January 1963, 26p. incl. illus, 8 refs. Unclassified Report</p> <p>The purpose of this study was to establish a technique for determining the radar cross-sectional area of any active radar augmenters. This proposal suggests that mathematical calculations are sufficiently accurate to allow test personnel to base conclusions on the calculated values. The theory and mathematics of the proposed technique were established, and an experiment was accomplished to obtain the accuracy of the computations. The overall accuracy of the method depended upon the accuracy of the computations plus the accuracy of the measuring instruments. Technique accuracy was found to be 1 db. Since an accuracy has been established, this technique can be utilized by test personnel when evaluating active radar augmenters. A five-step procedure for evaluation of an augmenters is presented.</p>	<p>1. Radar 2. Radar echo areas 3. Radar augmenters 4. Aerial targets I. AFSC Project 7826 II. Kantak, John F., 1st Lt, USAF III. In ASTIA collection</p>	<p>Air Proving Ground Center, Eglin Air Force Base, Florida Rpt No. APGC-TDR-63-1. ACTIVE RADAR AUGMENTER EVALUATION. A Validated Mathematical Approach. Final report, January 1963, 26p. incl. illus, 8 refs. Unclassified Report</p> <p>The purpose of this study was to establish a technique for determining the radar cross-sectional area of any active radar augmenters. This proposal suggests that mathematical calculations are sufficiently accurate to allow test personnel to base conclusions on the calculated values. The theory and mathematics of the proposed technique were established, and an experiment was accomplished to obtain the accuracy of the computations. The overall accuracy of the method depended upon the accuracy of the computations plus the accuracy of the measuring instruments. Technique accuracy was found to be 1 db. Since an accuracy has been established, this technique can be utilized by test personnel when evaluating active radar augmenters. A five-step procedure for evaluation of an augmenters is presented.</p>	<p>1. Radar 2. Radar echo areas 3. Radar augmenters 4. Aerial targets I. AFSC Project 7826 II. Kantak, John F., 1st Lt, USAF III. In ASTIA collection</p>	<p>Air Proving Ground Center, Eglin Air Force Base, Florida Rpt No. APGC-TDR-63-1. ACTIVE RADAR AUGMENTER EVALUATION. A Validated Mathematical Approach. Final report, January 1963, 26p. incl. illus, 8 refs. Unclassified Report</p> <p>The purpose of this study was to establish a technique for determining the radar cross-sectional area of any active radar augmenters. This proposal suggests that mathematical calculations are sufficiently accurate to allow test personnel to base conclusions on the calculated values. The theory and mathematics of the proposed technique were established, and an experiment was accomplished to obtain the accuracy of the computations. The overall accuracy of the method depended upon the accuracy of the computations plus the accuracy of the measuring instruments. Technique accuracy was found to be 1 db. Since an accuracy has been established, this technique can be utilized by test personnel when evaluating active radar augmenters. A five-step procedure for evaluation of an augmenters is presented.</p>
<p>Air Proving Ground Center, Eglin Air Force Base, Florida Rpt No. APGC-TDR-63-1. ACTIVE RADAR AUGMENTER EVALUATION. A Validated Mathematical Approach. Final report, January 1963, 26p. incl. illus, 8 refs. Unclassified Report</p> <p>The purpose of this study was to establish a technique for determining the radar cross-sectional area of any active radar augmenters. This proposal suggests that mathematical calculations are sufficiently accurate to allow test personnel to base conclusions on the calculated values. The theory and mathematics of the proposed technique were established, and an experiment was accomplished to obtain the accuracy of the computations. The overall accuracy of the method depended upon the accuracy of the computations plus the accuracy of the measuring instruments. Technique accuracy was found to be 1 db. Since an accuracy has been established, this technique can be utilized by test personnel when evaluating active radar augmenters. A five-step procedure for evaluation of an augmenters is presented.</p>	<p>1. Radar 2. Radar echo areas 3. Radar augmenters 4. Aerial targets I. AFSC Project 7826 II. Kantak, John F., 1st Lt, USAF III. In ASTIA collection</p>	<p>Air Proving Ground Center, Eglin Air Force Base, Florida Rpt No. APGC-TDR-63-1. ACTIVE RADAR AUGMENTER EVALUATION. A Validated Mathematical Approach. Final report, January 1963, 26p. incl. illus, 8 refs. Unclassified Report</p> <p>The purpose of this study was to establish a technique for determining the radar cross-sectional area of any active radar augmenters. This proposal suggests that mathematical calculations are sufficiently accurate to allow test personnel to base conclusions on the calculated values. The theory and mathematics of the proposed technique were established, and an experiment was accomplished to obtain the accuracy of the computations. The overall accuracy of the method depended upon the accuracy of the computations plus the accuracy of the measuring instruments. Technique accuracy was found to be 1 db. Since an accuracy has been established, this technique can be utilized by test personnel when evaluating active radar augmenters. A five-step procedure for evaluation of an augmenters is presented.</p>	<p>1. Radar 2. Radar echo areas 3. Radar augmenters 4. Aerial targets I. AFSC Project 7826 II. Kantak, John F., 1st Lt, USAF III. In ASTIA collection</p>	<p>Air Proving Ground Center, Eglin Air Force Base, Florida Rpt No. APGC-TDR-63-1. ACTIVE RADAR AUGMENTER EVALUATION. A Validated Mathematical Approach. Final report, January 1963, 26p. incl. illus, 8 refs. Unclassified Report</p> <p>The purpose of this study was to establish a technique for determining the radar cross-sectional area of any active radar augmenters. This proposal suggests that mathematical calculations are sufficiently accurate to allow test personnel to base conclusions on the calculated values. The theory and mathematics of the proposed technique were established, and an experiment was accomplished to obtain the accuracy of the computations. The overall accuracy of the method depended upon the accuracy of the computations plus the accuracy of the measuring instruments. Technique accuracy was found to be 1 db. Since an accuracy has been established, this technique can be utilized by test personnel when evaluating active radar augmenters. A five-step procedure for evaluation of an augmenters is presented.</p>