

UNCLASSIFIED

AD NUMBER
AD296437
NEW LIMITATION CHANGE
TO Approved for public release, distribution unlimited
FROM Distribution authorized to U.S. Gov't. agencies and their contractors; Administrative/Operational Use; 31 DEC 1962. Other requests shall be referred to Army Electronic Research and Development Laboratory, Fort Monmouth, NJ.
AUTHORITY
USAEC ltr dtd 13 May 1968

THIS PAGE IS UNCLASSIFIED

UNCLASSIFIED

---

AD 296 437

*Reproduced  
by the*

ARMED SERVICES TECHNICAL INFORMATION AGENCY  
ARLINGTON HALL STATION  
ARLINGTON 12, VIRGINIA



---

UNCLASSIFIED

NOTICE: When government or other drawings, specifications or other data are used for any purpose other than in connection with a definitely related government procurement operation, the U. S. Government thereby incurs no responsibility, nor any obligation whatsoever; and the fact that the Government may have formulated, furnished, or in any way supplied the said drawings, specifications, or other data is not to be regarded by implication or otherwise as in any manner licensing the holder or any other person or corporation, or conveying any rights or permission to manufacture, use or sell any patented invention that may in any way be related thereto.

UNCLASSIFIED

29 6437

CATALOGED BY ASTIA  
AS AD NO.

296 437

**INTEGRATED PRECISION TUNING SYSTEM**

**Fifth Quarterly Progress Report**

**October 1, to December 31, 1962**

**Report No. 5**

**CONTRACT NO. DA-36-039-SC-88908**

**SCTR NO. SCL-7566A (11 JANUARY 1961)**

**DA MO. 3D26-02-001**

AS I  
REC-18

**U.S. Army Electronic Research and Development Laboratory,  
Fort Monmouth, New Jersey**

**GMIIIID**

**GENERAL DYNAMICS | ELECTRONICS-ROCHESTER**

NO. 515

UNCLASSIFIED

**ASTIA Availability Notice**

Qualified Requestors may obtain copies of  
this report from ASTIA. ASTIA release to  
OTS not authorized.

UNCLASSIFIED

INTEGRATED PRECISION TUNING SYSTEM

Fifth Quarter Progress Report  
October 1 to December 31, 1962

Contract No. DA-36-039 SC-88908  
SCTR No. SCL-7566A (11 January 1961)  
DA No. 3D 26-02-001

Report Prepared by: G. Luhowy

General Dynamics/Electronics  
Communications Equipment Laboratory  
Rochester 3, New York

UNCLASSIFIED

## TABLE OF CONTENTS

	Page
1. PURPOSE . . . . .	1
2. ABSTRACT . . . . .	2
2.1 Generation of the Digital Tuning Voltage . . . . .	2
2.2 Packaging of the Development Model . . . . .	3
3. CONFERENCES . . . . .	3
3.1 Conference at USAERDL, Ft. Monmouth, New Jersey on 3 October 1962 . . . . .	3
3.2 Conference at GD/E-Rochester with Pacific Semiconductor Regional Representative on 4 October 1962 . . . . .	3
3.3 Telephone Conversation with USAERDL, Ft. Monmouth, New Jersey on 4 October 1962 . . . . .	4
3.4 Conference at GD/E-Rochester with Corning Glass Works Regional Representative on 5 October 1962 . . . . .	4
3.5 Telephone Conversation with Eastron Corporation, Haverhill, Massachusetts on 1 November 1962 . . . . .	4
3.6 Telephone Conversation with Indiana General Corporation, Keasbey, New Jersey, on 2 November 1962 . . . . .	5
3.7 Telephone Conversation with Pacific Semiconductor Corporation, Lawndale, California on 16 November 1962 . . . . .	5
3.8 Telephone Conversation with Philco Corporation, Lansdale, Pennsylvania on 20 November 1962 . . . . .	5
4. FACTUAL DATA . . . . .	6
4.1 Generation of a Digital Tuning Voltage . . . . .	6
4.2 Methods of Obtaining a Non-Linear Voltage . . . . .	7
4.2.1 The Switched Resistor Divider . . . . .	10
4.2.2 A Ganged Switched Resistor Divider . . . . .	15
4.2.3 The Diode Shaping Circuit . . . . .	15

TABLE OF CONTENTS (continued)

	Page
4.2.3.1 General Description . . . . .	15
4.2.3.2 Application of the Diode Shapes for Course Tuning . . . . .	19
4.2.3.3 The Digitally Switched Staircase Generator . . . . .	20
4.2.3.3.1 The Linear Resistor Staircase Generator . . . . .	20
4.2.3.3.2 A Constant Current Source and Binary Coded Resistors . . . . .	23
4.2.3.3.3 An Operational Amplifier and BCD Resistors . . . . .	23
4.3 Packaging of The RF Amplifier . . . . .	28
4.3.1 General . . . . .	28
4.3.2 The Sub Modules . . . . .	28
5. CONCLUSION . . . . .	38
6. PROGRAM FOR NEXT INTERVAL . . . . .	39
7. IDENTIFICATION OF KEY PERSONNEL . . . . .	39
8. ACKNOWLEDGEMENTS . . . . .	39
9. ADDENDUM TO THE FOURTH QUARTERLY REPORT . . . . .	39

## LIST OF ILLUSTRATIONS

Figure	Page
1. Graph of Coarse Tuning Voltage vs. Frequency . . . . .	8
2a. Ganged Linear Potentiometer to Obtain a Non- Linear Output .	9
2b. Approximation to the Coarse Tuning Voltage by the Circuit of Figure 2a with $K = 2$ . . . . .	9
3a. A Resistive Divider Circuit . . . . .	11
3b. A Variation of Figure 3a . . . . .	11
4. Graph Showing Approximation to Desired Curve Generated by The Linear Resistive Divider Circuit . . . . .	13
5a. A Method of Deriving a Non-Linear Voltage in Digitally Related Increments . . . . .	14
5b. A Sketch of a Switch Wafer Which Will do the Switching Indicated in Figure 3a . . . . .	14
6. Linear Approximation of the Coarse Tuning Curve . . . . .	16
7a. The Diode Shaper . . . . .	18
7b. The Diode Shaper Equivalent Circuit . . . . .	18
8a. Block Diagram of the Linear Resistive Divider and Diode Shaper Tuning Scheme . . . . .	21
8b. Staircase Voltage vs. Normalized Frequency . . . . .	21
8c. Shaper Output vs. Normalized Frequency . . . . .	21
9a. A Linear Resistor Divider Staircase Generator . . . . .	22
9b. A Constant Current Source Staircase Generator . . . . .	24
9c. An Operational Amplifier Staircase Generator . . . . .	26
10. Assembly Drawing . . . . .	27
11. Oscillator and Amplifier Sub-Modules . . . . .	31
12. Input Circuit and Mixer Sub-Modules . . . . .	32
13. Rotor Wafer Sub-Assembly Showing One Switched Tank Circuit.	33
14. Hinged Cover With Amplifier and Oscillator Sub-Modules Mounted . . . . .	34

LIST OF ILLUSTRATIONS (continued)

Figure	Page
15. Hinged Cover With Input Circuit and Mixer Sub-Modules Mounted . . . . .	35
16. View Showing Inside of Stator Block Assembly . . . . .	36
17. View Showing Hinged Covers and Stator Assembly . . . . .	37

1. PURPOSE

This is the Fifth Quarterly Report: discussing progress in the development of an electronically controlled tuning system. The objective of this task is the development of an electronically controlled tuning system leading to the establishment of a prototype for future electronic communications equipment tuner needs, and the basis for future development and study. The first task of the program is to study, investigate, and develop an accurate method of electronically tuning an RF front end covering the 3 to 12 mc/s range. The detailed system objectives of the tuner are specified in Signal Corps Technical Requirement SCL-7566A. Other tasks in the program are the development of (a) two experimental models and (b) two developmental models.

## 2. ABSTRACT

### 2.1 Generation of the Digital Tuning Voltage

A number of techniques for generating the digitally controlled coarse tuning voltage are discussed. Several circuits are investigated and the results are presented. Advantages and disadvantages of the various techniques are pointed out.

### 2.2 Packaging of the Development Models

A brief discussion of the packaging techniques used to construct the Development Models is given. Photographs and assembly drawings are presented in order to emphasize salient features.

### 3. CONFERENCES

#### 3.1 Conference at USAERDL, Ft. Monmouth, New Jersey, on 3 October 1962

Present at the meeting were Messr's R. Tilton, J. W. Gruol, and H. Stout of USAERDL, and F. S. J. Daniel and G. J. Luhowy of GD/E.

The contents of the Fourth Quarerly Report were discussed. The contents were approved for publication provided the graphs and charts were redrawn.

It was agreed that the DC - DC Converter would be located in the synthesizer package on the Development Models. It was agreed that band switching of the RF Amplifier would be accomplished by mechanically coupling to the megacycle knob on the synthesizer package.

Sketches of the proposed packaging scheme were discussed at length. Further reduction of volume would require smaller trimmer capacitors and micro-miniature components such as the "dot" resistors and capacitors. This was deemed not desirable for the present program.

#### 3.2 Conference at GD/E - Rochester with PSI's Regional Representative on 4 October 1962

Messr's Cal Tainter and Bob Reid of PSI, and G. J. Luhowy of GD/E, met to discuss a composite voltage variable capacitor which would duplicate the six individual units presently used per tuned circuit. It was determined that PSI has the capability of packaging as many of their micro-diodes as we wish in their "Thinline" package. A call placed to the factory yielded the following pricing information for the micro-diode Varicaps<sup>®</sup>.

20% tolerance units	1 - 99	\$25.00	100 up	\$18.75
5% tolerance units	1 - 99	\$75.00	100 up	\$56.25

<sup>®</sup> Registered Trademark, Pacific Semiconductors

Packaging these individual diodes into a composite unit with a 5 percent overall capacitance tolerance was thought feasible but pricing was not available.

3.3 Telephone Conversation with USAERDL, Ft. Monmouth, New Jersey on 4 October 1962

Mr. R. Tilton was given a summary of the conference with PSI. It was agreed by Messr's Tilton and F. S. J. Daniel of GD/E that spending approximately \$2000 for 100 PSI micro-diode Varicaps<sup>®</sup> was not desirable at this stage in the program because the smaller volume of these components would not significantly change the size of the overall package, and no electrical improvement would be realized.

3.4 Conference at GD/E with Corning Glass Works, Regional Representative on 5 October 1962

A conference was held with Mr. Brennan of Corning Glass to determine the suitability of Corning's Photoceram for the wafer switch sections of the RF tuner. The following is a summary of the material properties of importance.

- a. Polishing to optical smoothness is no problem
- b. Plated-through holes are no problem
- c. Plating can be accomplished only up to within .055 of an edge
- d. Grinding down the edges of oversize pieces is not practical
- e. A visible warp (.003 to .005 in.) would probably result in material of .015 in. thickness.

It was concluded that although the material had some very desirable properties, it was not usable because of the warpage expected, and because plating up to an edge was not possible, nor was it feasible to grind away an unplated edge.

3.5 Telephone Conversation with Eastron Corporation, Haverhill, Massachusetts on 1 November 1962

A call was placed to Mr. William E Slusher, Sales Manager of Eastron

Corporation, concerning the possibilities of obtaining a voltage variable capacitor with a 5:1 capacitance ratio. Mr. Slusher agreed to write a letter describing the general design and fabrication techniques required to develop such a device.

3.6 Telephone Conversation with Indiana General Corporation, Keasley, New Jersey on 2 November 1962

A call placed to Mr. Joseph Venerus for further information on the TC-4. material resulted in the following data:

Tooling for small cup cores, both fixed gap and adjustable is no problem.

A new set of standard sizes ranging from 0.5 in O.D. will be available shortly.

3.7 Telephone Conversation with Pacific Semiconductors Corporation, Lawndale, California on 16 November 1962

Mr. Bernie Bergman described the 1N3557 high voltage, high Q voltage variable capacitor which was recently made for the Signal Corps. The device has a nominal capacitance of 19.2 to 28.8 pf at -8 volts bias, a capacitance ratio of 5:1 with a voltage swing from -4 to -200 volts, and a Q of 75 at 50 mc with 8 volts bias.

Mr. Bergman said there were no samples available, and they were not in production.

3.8 Telephone Conversation with Philco Corporation, Lansdale, Pennsylvania on 20 November 1962

During a conversation with Mr. Gilbert Waite, it was learned that the Philco voltage variable capacitor line would include the following capacitors:

47 pf, 150 pf, 250 pf, 500 pf and 100 pf.

The maximum voltage of the present units is 150 volts. Currently the devices are available in small quantities, but pilot production is expected to begin the second quarter of 1963, and larger quantities will be available. The cost of these units is expected to drop considerably when pilot production begins.

#### 4. FACTUAL DATA

##### 4.1 Generation of a Digital Tuning Voltage

From the beginning of this project it was recognized that using the Voltage Variable Capacitor (VVC) as the tuned element in an RF amplifier would present unique tuning problems. Because the capacitance vs. voltage law for the VVC approximates a  $V_b^{-1/2}$  law, and the resonant frequency of an LC tank circuit is proportional to  $C^{-1/2}$ , the frequency vs. voltage law for a circuit tuned with VVC's would approximate a  $V_b^{-1/4}$  law neglecting stray or trimmer capacitance. That is:

$$C_{VVC} \approx K_1 V_b^{-1/2}$$

$$f = \frac{1}{2\pi \sqrt{LC}} = K_2 C^{-1/2}$$

$$\therefore f = K_2 (K_1 V_b^{-1/2})^{-1/2} = K' V_b^{-1/4}$$

where  $V_B =$  VVC bias voltage,  $f =$  resonant frequency,  $K_1, K_2, K'$  are constant.

The first experiments run on the program showed that there was a practical minimum to the bias voltage which could be impressed across the VVC if cross-modulation was to be kept within reason. This minimum bias restriction reduced the available capacitance ratio and meant that a number of bands would be required to tune the 3 mc to 12 mc frequency range of the amplifier. Because of the digital tuning requirement it was felt that considerable mechanical complication in an end use equipment, i. e. , a receiver or transceiver would be avoided if the bands began and ended on an integral megacycle. Imposing this restriction, it was then shown that five bands with four different tuning ratios were required to cover the 3 to 12 mc range. Four different tuning ratios meant

four different values for the trimmer capacitance across each of the tank circuits, and this meant four different curves of frequency vs. tuning voltage.

To generate four different tuning voltage characteristics looked like quite a complicated thing, especially when component tolerances, tracking error, and tuning accuracy were considered. It was decided that the best practical solution to the problem was to tune the tank circuits with two voltages, a coarse tuning voltage and a fine tuning voltage. The coarse tuning voltage would be the average of the four required tuning curves, and the fine tuning voltage would be derived by phase-locking the amplifiers local-oscillator to an external accurate frequency standard or frequency synthesizer. Considerable effort was expended on developing a phase locked loop and that was described previously.<sup>1</sup> To date, very little has been said about deriving the coarse tuning voltage. The first portion of this report, therefore, will be devoted to a discussion of techniques for obtaining the coarse tuning voltage.

#### 4.2 Methods of Obtaining a Non-Linear Voltage

A variety of methods for obtaining a non-linear voltage for the coarse tuning functions are available, some of which are a calibrated linear potentiometer, a calibrated non-linear potentiometer, ganged linear potentiometers, switched resistor divider networks, and non-linear function generators.

Perhaps the simplest way to obtain the coarse tuning voltage is with a ten-turn linear potentiometer and a calibration curve. Alternatively, a non-linear potentiometer can be made to match the curve, thus, allowing linear frequency vs. shaft rotation; but for some curves this can be expensive and/or impractical. The calibration curve and ten-turn potentiometer method has been used for bread-board evaluation. The non-linear potentiometer was not investigated.

Ganged linear potentiometers offer another rather interesting way of approximating many non-linear curves.<sup>2</sup> Figure 2(a) shows a schematic of an arrange-

---

<sup>1</sup> Quarterly Report No. 2

<sup>2</sup> Reference No. 5 in Bibliography

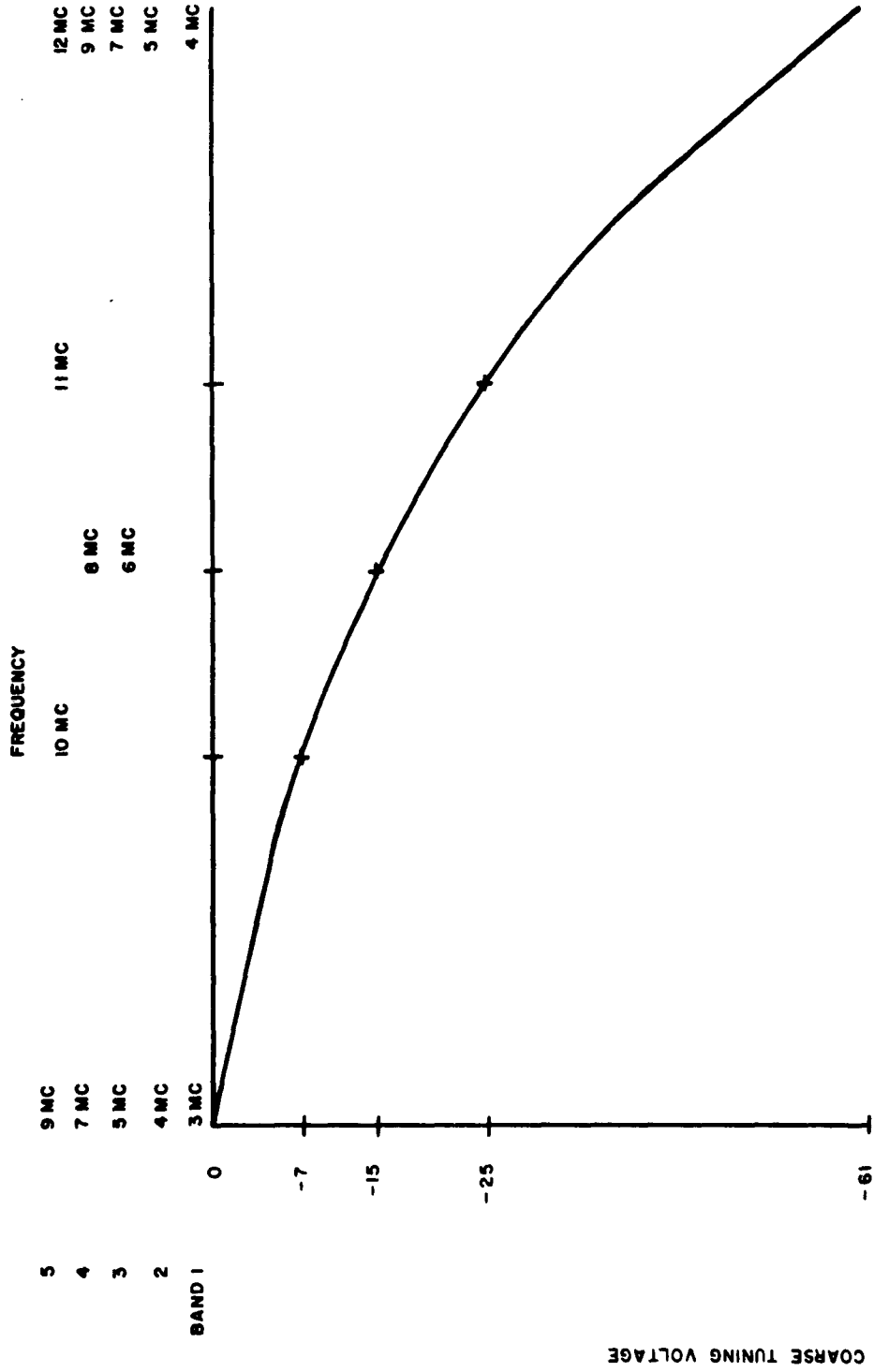

Figure 1. Graph of Coarse Tuning Voltage vs. Frequency

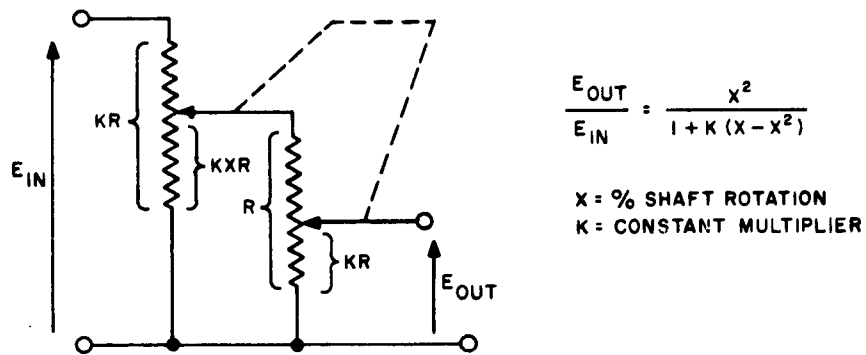

Figure 2(a). Gauged Linear Potentiometer to Obtain a Non-Linear Output with Linear Shaft Rotation

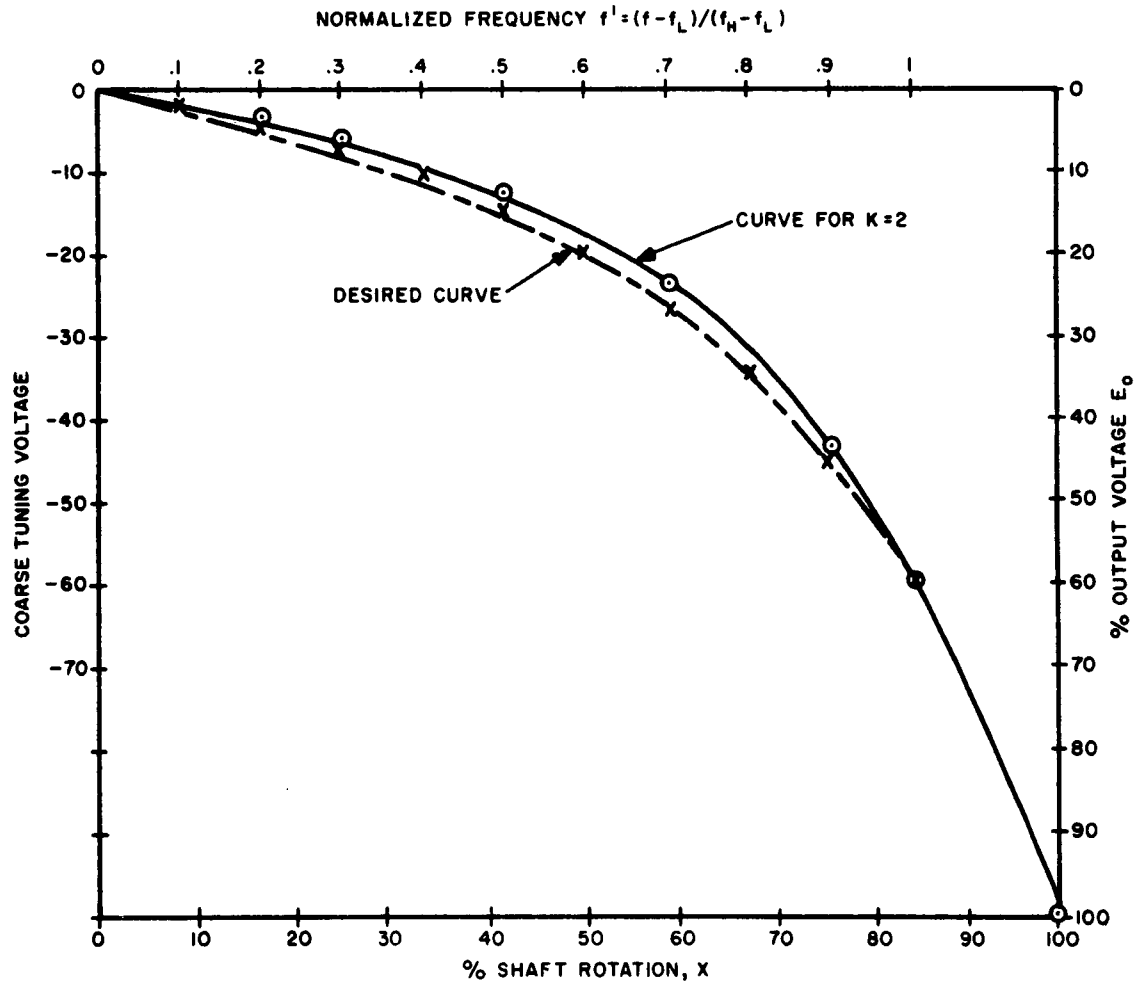

Figure 2(b). Approximation to the Coarse Tuning Voltage by Circuit of Figure 2(a) with  $K = 2$

ment which is usable for obtaining a non-linear curve similar to that required. For K equal to 2 and the pot rotation restricted to approximately 85 percent of the total a curve closely approximating that required can be obtained as shown in Figure 2(b). Closer approximation can be obtained with a slightly smaller value for K. Because of the digital tuning requirement, considerable mechanical complication would ensue, particularly on those bands covering more than one megacycle. It was estimated for example that a mechanical differential and at least one spur gear would be required per shaft. For this reason, the technique was not investigated in further detail.

The switched resistor divider network is closely related to the ganged linear potentiometer technique. A variety of circuit configurations are possible, two of which are discussed in the next section, and one which was constructed for a preliminary evaluation.

Finally, the non-linear function generator techniques for obtaining "arbitrary" functions are available. Again, there exists a variety of methods including magnetic waveform generators, optical flying spot scanners, servo driven recorders, magnetic-stylus-pickup schemes, and diode shaping circuits.<sup>3</sup> Of these, only the diode shaping circuit was considered for this application, and it is discussed in detail in a later section.

#### 4.2.1 The Switched Resistor Divider

A circuit which will approximate the curve of Figure 1 in discrete digital steps is shown in Figure 3(a). Resistors  $R_1$  and  $R_2$  are switched to obtain the megacycle voltage increments,  $R_3$ ,  $R_4$ , and  $R_5$  to obtain the 100 kc voltage increments, and  $R_6$  and  $R_7$  to obtain the 10 kc increments.

Resistors  $R_1$  and  $R_2$  determine the voltage limits applied to the remainder of the resistor string. Referring to Figure 1, when the 3 to 4 megacycle range, or the 4 to 5 megacycle range is desired, the values of  $R_1$ ,  $R_2$ , and  $R_3$  are ad-

<sup>3</sup> Reference No. 6, pp. 136-164



justed, such that zero volts is present at the junction of  $R_2$  and  $R_3$ , and -61 volts is at the junction of  $R_1$  and  $R_2$ . When in the 5 to 6 or 7 to 8 megacycle ranges, the former voltage is again zero volts, but the latter is made to equal -15 V. In the 6 to 7 or 8 to 9 mc range, the limits are -15 V and -61 V respectively and so on.

The sum of the resistances ( $R_4 + R_5 + R_6 + R_7$ ) is made large enough so that there is negligible loading on the input string.

If the ratios of  $R_4$ ,  $R_5$ ,  $R_6$ , and  $R_7$  are now chosen such that the curve for the 3 to 4 mc range is approximated, a reasonably close correlation can be achieved. However, when a band is switched in which uses only a portion of the whole curve to cover a megacycle range, a large error is generated, because changing  $R_1$  and  $R_2$  affects only the voltage at the end points of the output but has no effect on the shape of the curve. This is illustrated in Figure 4 for the 10 to 11 megacycle range. The error constitutes a major disadvantage of this technique for obtaining the non-linear voltage. The circuit could be designed so that the six different curve segments required were generated, but it would take 240 resistors, and obviously, this is an undesirable feature.

A variation on this circuit, such that the input voltage to the 100 kc and 10 kc voltage dividers is kept at -61 volts is shown in Figure 3(b). The circuit is the same as 3(a) except  $R_1$ ,  $R_2$ , and  $R_3$  are removed. Hence, there is no change when the megacycle range is changed. In this case, when in Bands 1 and 2, the "10 kc" knob would generate 10 kc increments, in Bands 3 and 4 the increments would be 20 kc, and in Band 5, 30 kc. If this circuit were used in an actual equipment, a mask indicating the change in calibration would have to be switched by the megacycle knob.

For some equipments, such a simple circuit might very well be completely adequate, but for this particular design, the tracking error, particularly on Band 3 would be excessive and a more accurate coarse tuning voltage is necessary.

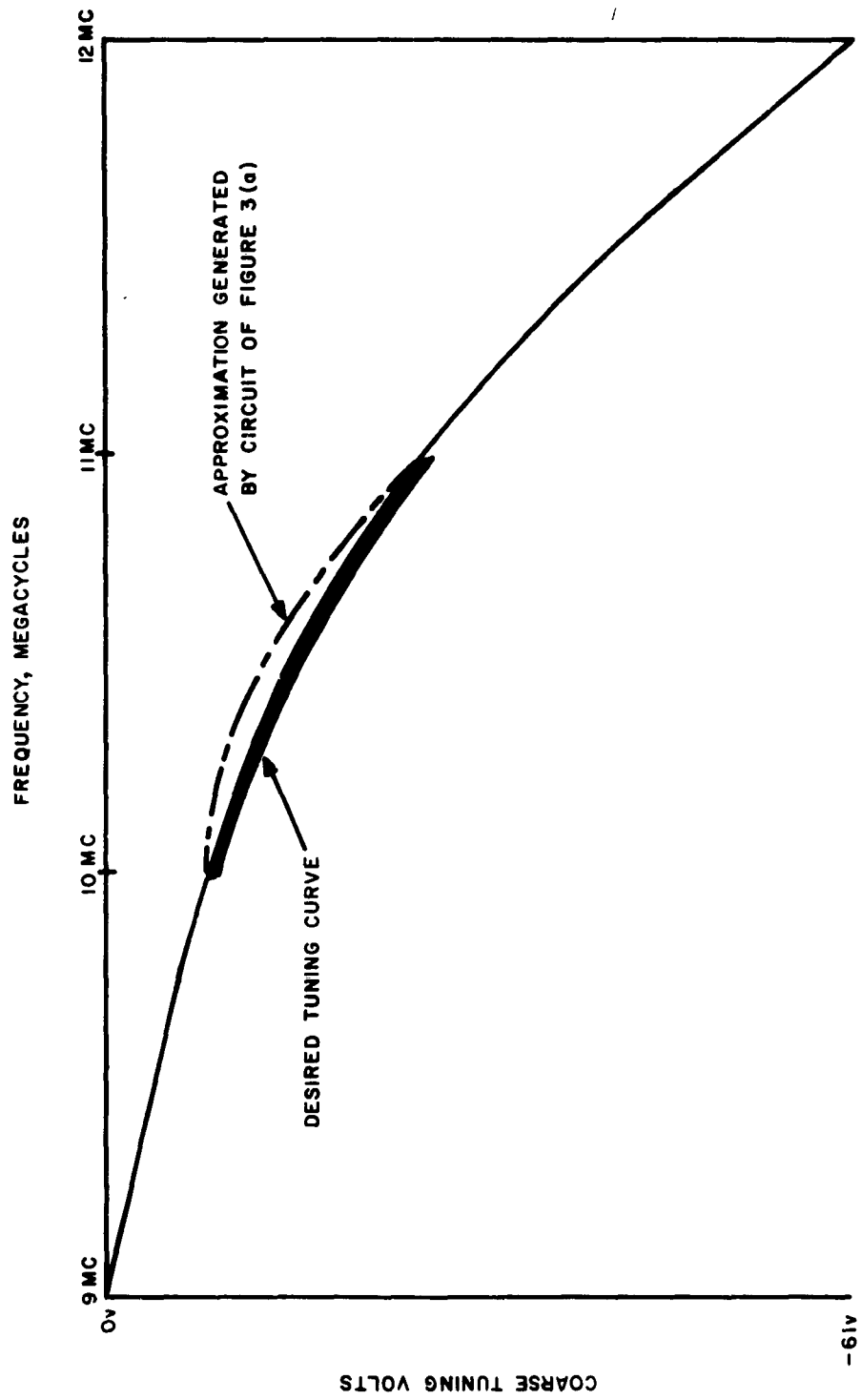

Figure 4. Graph Showing Approximation to Desired Curve Generated by Linear Resistive Divider Network

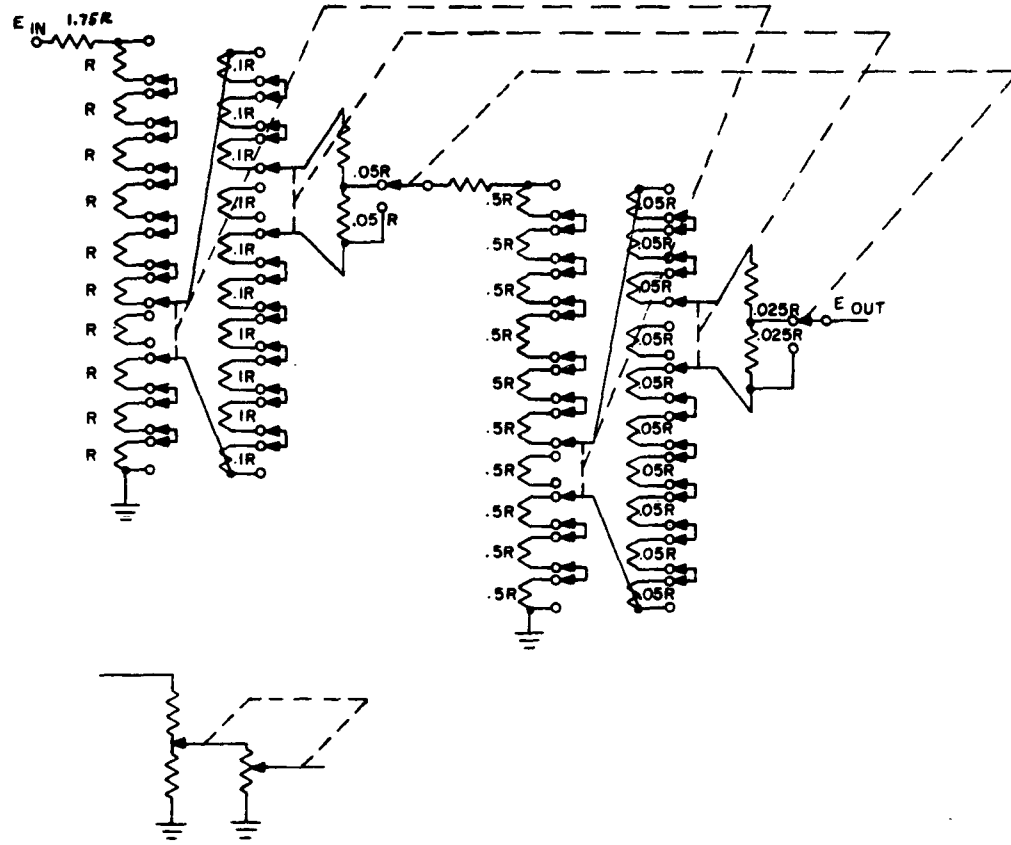

Figure 5(a). A Method of Deriving a Non-Linear Voltage in Digitally Related Increments

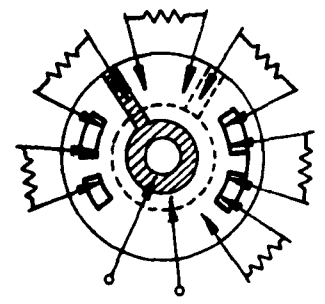

Figure 5(b). A Sketch of a Switch which will do the Switching Indicated in Figure 3(a).

#### 4.2.2 A Ganged Switched Resistor Divider

A variation of the ganged potentiometer circuit using discrete resistors is shown in Figure 5(a). The equivalent circuit and transfer function is exactly the same as Figure 2(a). Therefore, the circuit can generate the same curve as that of 2(a) except elaborate mechanisms are not required. Figure 5(b) shows a sketch of a type wafer which could do the required switching.

Unfortunately this circuit did not occur to the writer until some time after the investigation into the digital tuning techniques had taken place, and consequently a thorough investigation was not made. Initially, it was felt that the circuit would have the same disadvantages as that of Figure 3(a) if megacycle digits were switched, and the circuit was consequently drawn up to switch only the 100 kc and 10 kc digits. In other words, it was another way of accomplishing what the circuit of Figure 3(b) would do. However, it has since occurred to the writer that a rather unique method of changing the shape of the entire output curve exists by changing only the top resistor in the first string. (It has the value  $1.75 R$  and  $.875 R$  in the schematic of 5(a)). The effect of varying this resistor is the same as restricting the percentage of total shaft rotation for the dual potentiometer arrangement. It may be possible to accomplish megacycle switching and still approximate the entire curve or any segment of it by a judicious choice of the input voltages and input resistors. This will be looked into in the future if time permits.

The resistor ratios for the circuit of 5(a) were derived for  $K = 2$ .

#### 4.2.3 The Diode Shaping Circuit

##### 4.2.3.1 General

A powerful method of generating a non-linear curve is by linear interpolation using biased diodes. The curve is approximated by a series of straight line segments as shown in Figure 6, each segment determined by the conduction or non-conduction of a biased diode. Intersections of segments are called break points,

1

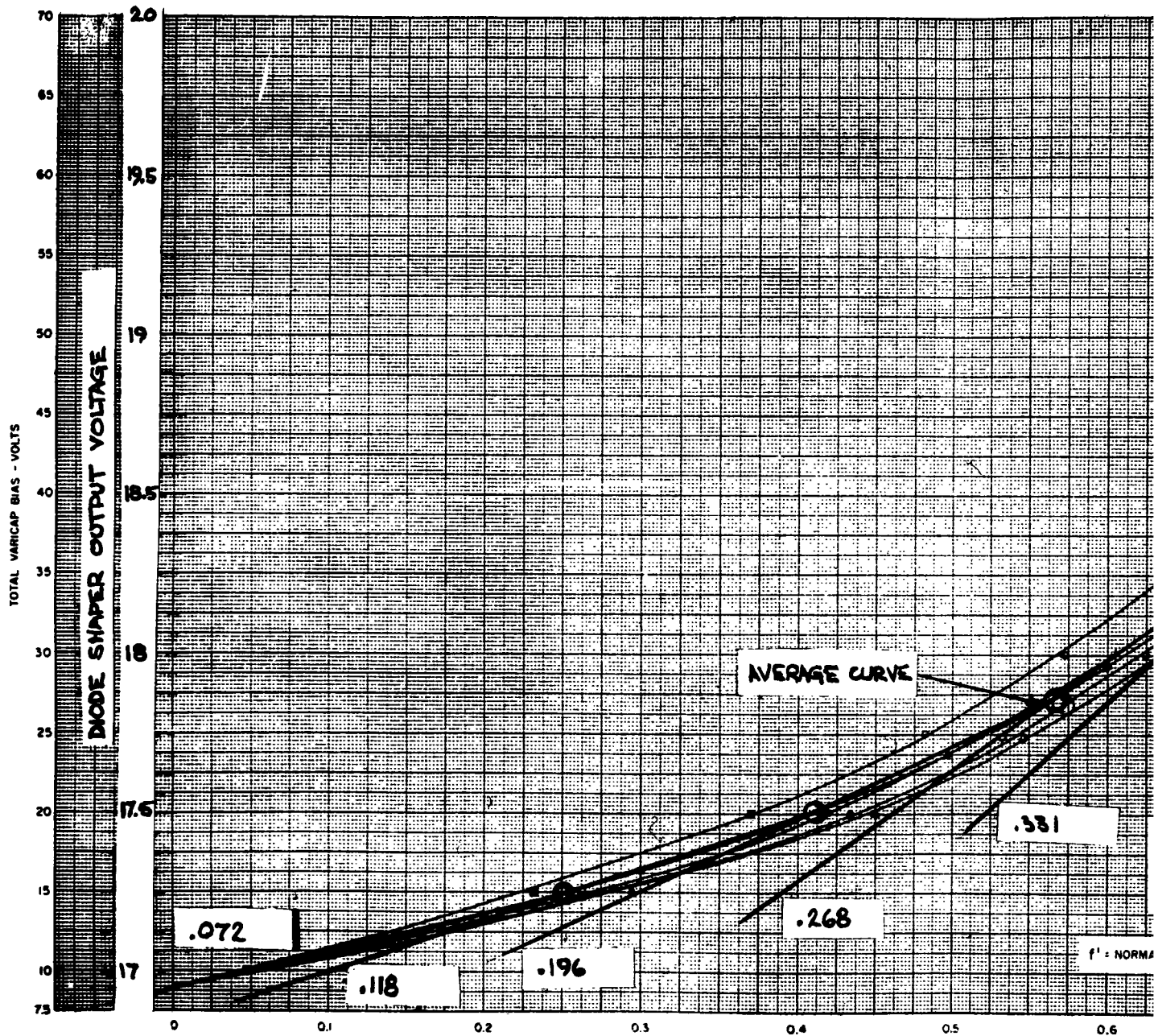

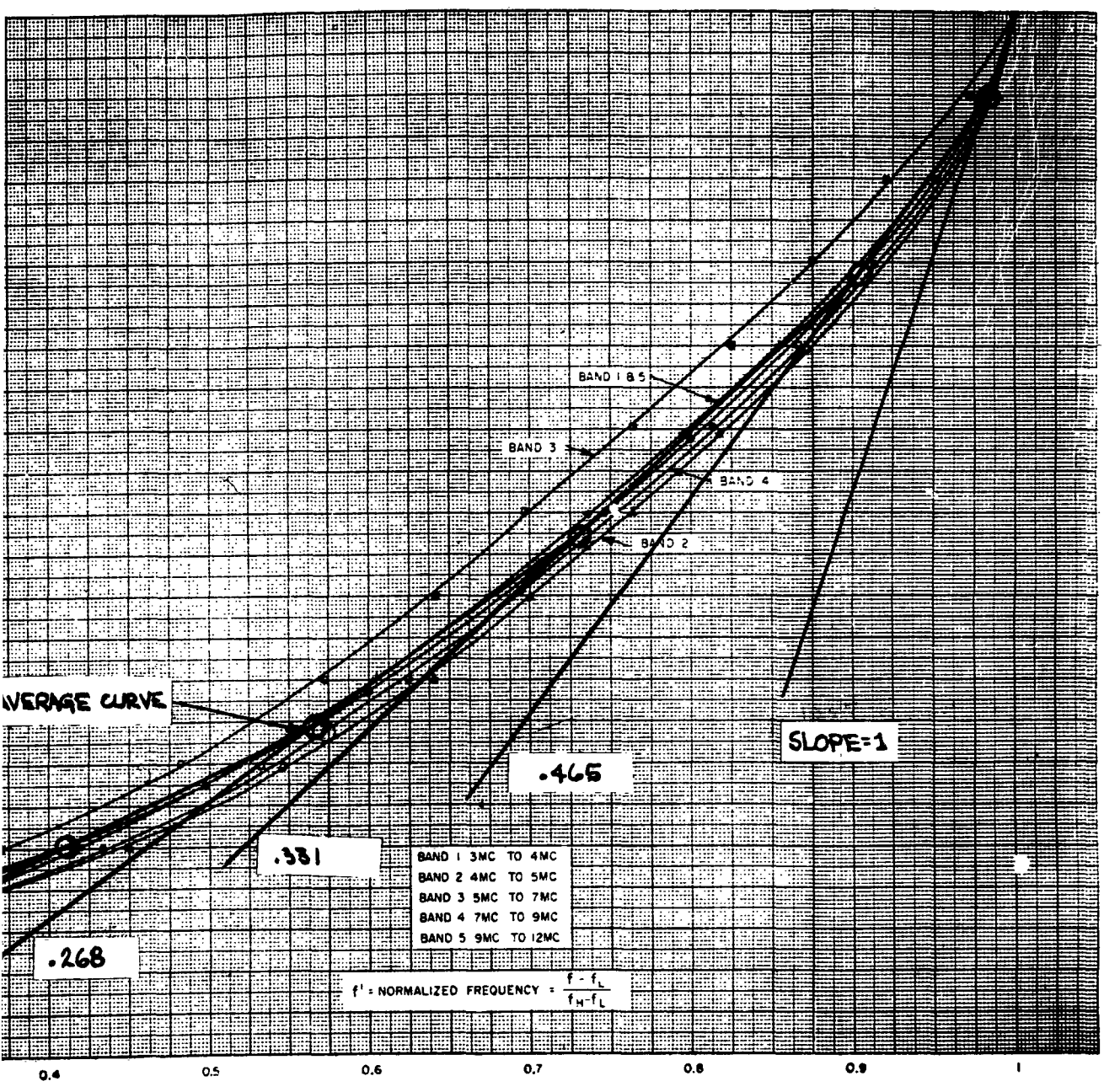

Figure 6. Linear Approximation to the Coarse Tuning Curve

and the magnitudes of the output voltages at which the diodes start or stop conduction are related to the break points. The easiest way to explain the operation of a diode shaper is to assume that the diode acts like an ideal switch which opens (or closes) at the instant the output voltage is equal to the bias voltage. Figure 7(a) shows the schematic of one type of diode shaper and Figure 7(b) shows its approximate equivalent circuit. Assume that the input voltage  $E_{in}$  is a negative going ramp. When the input voltage is greater than the highest bias voltage, all the diodes are back-biased, and the output voltage is equal to the input voltage. As the output voltage drops to the value  $E_1$ , diode  $D_1$  begins to conduct, the slope of the output becomes equal to  $(-R_1)/(R_g + R_1)$  and the value of  $E_{out}$  is given by

$$E_{out} = E_1 - \frac{E_{in} R_1}{R_g + R_1}$$

As  $E_{in}$  continues downward,  $E_{out}$  decreases, but at a slower rate until  $E_{out}$  equals  $E_2$ . Diode  $D_2$  now begins to conduct, and the slope of the output becomes less since  $R_2$  is placed in parallel with  $R_1$ . The output voltage becomes

$$E_{out} \approx E_2 - E_{in} \frac{R_{eg}}{R_g + R_{eg}}$$

$$\text{where } R_{eg} = \frac{R_1 R_2}{R_1 + R_2}$$

When  $E_{out} = E_3$  diode  $D_3$  conducts and the slope decreases again,  $R_3$  being in parallel with  $R_1$  and  $R_2$ .  $E_{out}$  is given by

$$E_{out} \approx E_3 - E_{in} \frac{R_{eg}'}{R_g + R_{eg}'}$$

$$\text{where } R_{eg}' = \frac{1}{\frac{1}{R_1} + \frac{1}{R_2} + \frac{1}{R_3}}$$

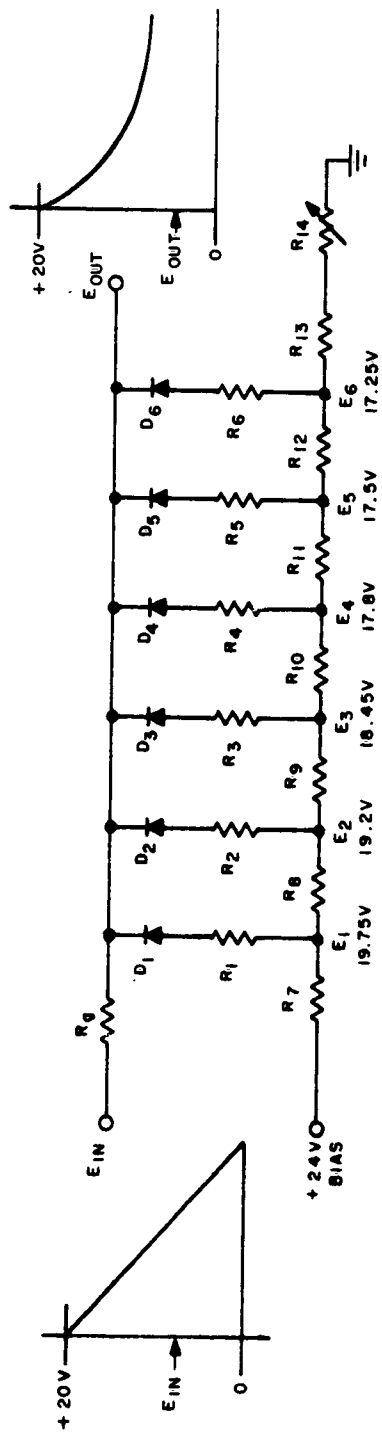

Figure 7(a). Diode Shaper

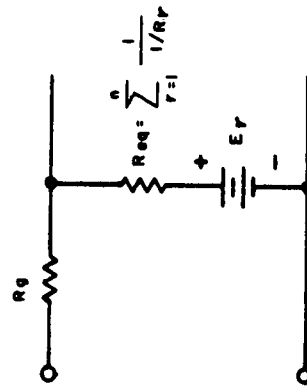

Figure 7(b). Approximate Equivalent Circuit for the Diode Shaper

Similar action takes place until all the diodes are conducting whereupon no further decrease in slope takes place.

From the above description, five things should be noted:

1. The number of break points is equal to the number of diodes in the network.
2. The maximum possible slope is unity (i. e. ,  $\Delta E_o = \Delta E_i$ ).
3. The piecewise linear response is completely defined by location of the breakpoints and determining the slopes of the intersecting segments.
4. Voltage sources can shift a segment location but cannot alter its slope.
5. The break voltage values are the bias voltages appearing in series with the branch diodes.

Therefore, by plotting the desired curve on a piece of graph paper, drawing in straight line approximations, and using the five rules above, any curve which is a function of one variable and has a continuous derivative may be generated. The degree of accuracy will depend on the number of segments used although references 2 and 3 describe ways of improving accuracy for a given number of segments by special techniques.

Additional information on diode shaping circuits is contained in references 1, 2, 3, 4, and 8 in the Bibliography.

#### 4.2.3.2 Application of the Diode Shaper for Coarse Tuning

The diode shaper is ideally suited for generating the digital coarse tuning voltage required for the RF amplifier. It has already been shown that the circuit can approximate non-linear curves quite accurately, and if the ramp function used for explanation in the previous section is replaced by a voltage whose magnitude is digitally related to the frequency of operation - in other words, a staircase voltage, with each step corresponding to a 5 kc frequency increment - the required non-linear (but digitally controlled) tuning curve can be obtained. That is, a digitally synthesized voltage analogue corresponding to the required tuning characteristic can be obtained.

Figure 8(a) shows a block diagram of the functions required to accomplish this. The output amplifier is a DC amplifier which merely amplifies the output from the shaper to the amplitude required for tuning the RF circuits. It would not be necessary if a sufficiently high amplitude (0 to -61 volts) curve were obtained directly from the shaper, but this is impractical since an input of more than 200 volts would be required. The diode shaper circuit has already been explained. It remains now to look at methods which will generate the linear digitally controlled staircase generator.

#### 4.2.3.3 The Digitally Switched Staircase Generator

For ease of explanation, a negative going range was used to describe the operation of the circuit of Figure 7. To tune the RF amplifier however, a ramp, or staircase which increases in the positive direction with increasing frequency is required. Figure 8(b) shows the output that the staircase generator must produce in order to tune the various megacycle bands. It is assumed that the diode shaper will generate the tuning curve of Figure 1 although it will be inverted. When the entire range of voltages from O to E of Figure 8 is applied to the input of the shaper, the output will be the whole of the required tuning curve. When only a portion of the input is applied, as is the case when tuning from 5 to 6 megacycles for example, only that corresponding portion of the shaper output will be developed.

Referring to Figure 8(b), it is obvious that the staircase generator must produce the correct end-point voltages, and then it must divide the voltage between these points into increments corresponding to 5 kc in frequency or  $(5 \text{ kc}/1 \text{ mc}) \times E = .005E$  in voltage. There are a number of circuits which will do this, and three of them are described below.

##### 4.2.3.3.1 The Linear Resistor Staircase Circuit

Shown in Figure 9(a) is a straightforward method of obtaining the required staircase voltage. Switch SW1 selects the total input voltage applied across a

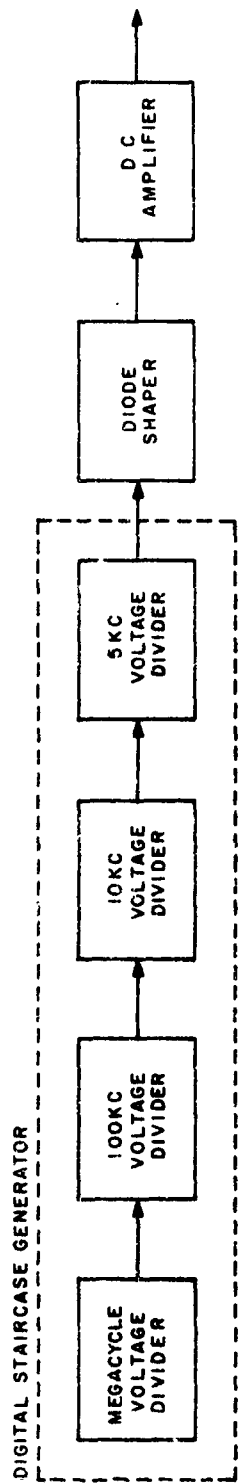

Figure 8(a). Block Diagram of the Linear Resistive Divider and Diode Shaper Digital Tuning Scheme

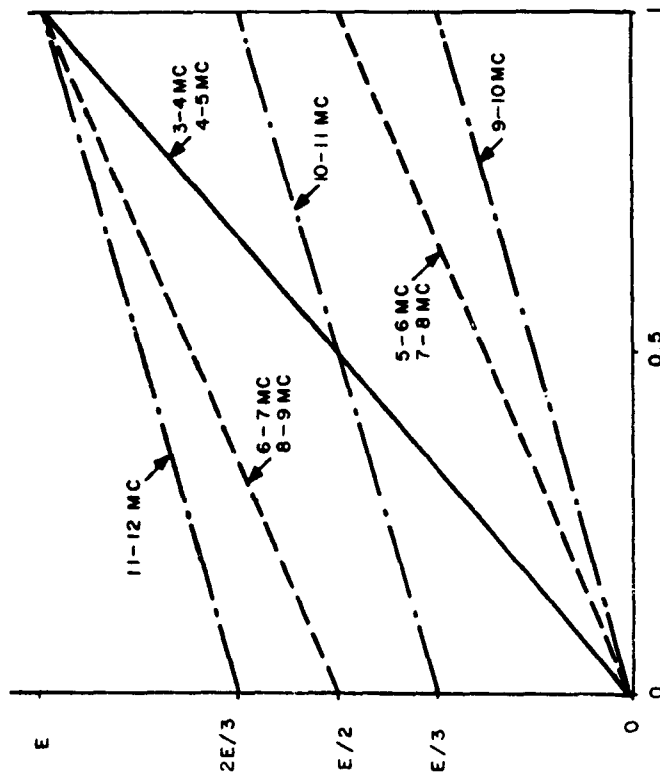

Figure 8(b). Staircase Voltage vs. Normalized Frequency

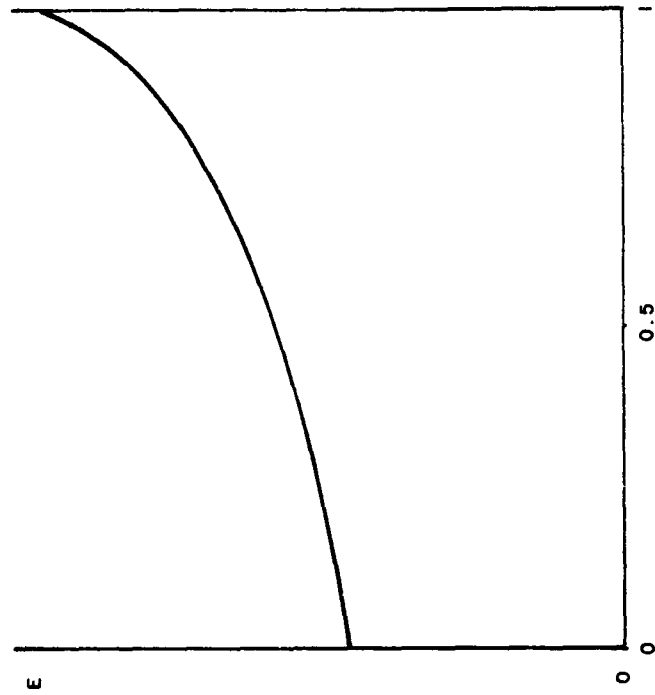
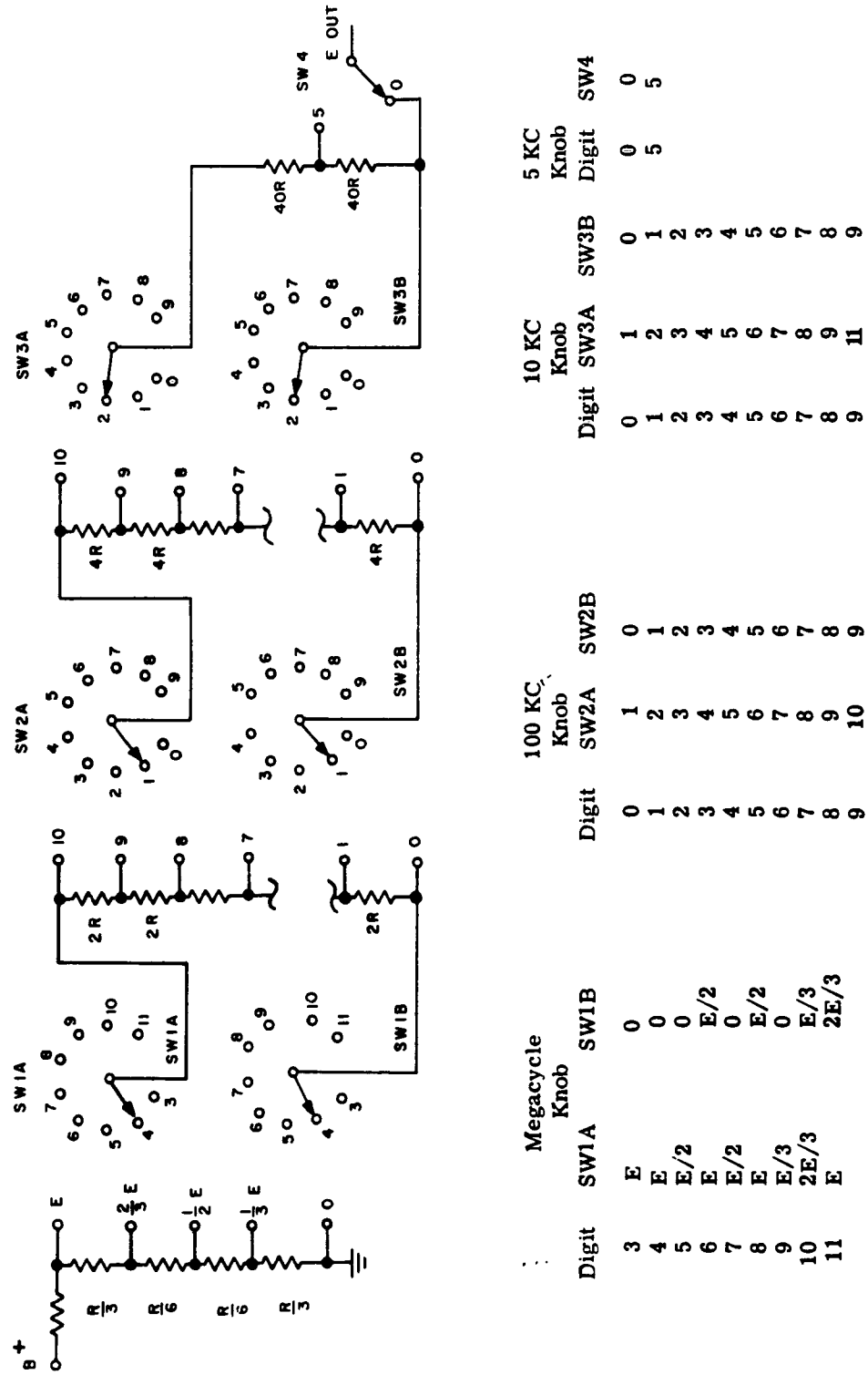

Figure 8(c). Shaper Output vs. Normalized Frequency



Digit	Megacycle Knob	SW1A	SW1B	100 KC Knob	SW2A	SW2B	10 KC Knob	SW3A	SW3B	5 KC Knob	SW4
3	E		0	1	0		0	1	0	0	0
4	E		0	2	1		1	2	1	5	5
5	E/2		0	3	2		2	3	2		
6	E		E/2	4	3		3	4	3		
7	E/2		0	5	4		4	5	4		
8	E		E/2	6	5		5	6	5		
9	E/3		0	7	6		6	7	6		
10	2E/3		E/3	8	7		7	8	7		
11	E		2E/3	9	8		8	9	8		
				10	9		9	11	9		

Figure 9(a). A Linear Resistor Divider Staircase Generator

string of ten equal resistors. This voltage is determined by megacycle increment selected and the ten equal resistors divide it into 100 kc segments. SW-2 chooses the 100 kc increment which is divided into 10 kc segments by the next resistor string. SW-3 selects the desired segment which is divided in half by the two equal resistors allowing a 5 kc segment to be chosen by SW-4. The three main sources of error are the stability of the B plus supply, the tolerance on the resistors, and the loading effect caused by a resistor string being shunted across a resistor from a preceding string. If the resistor strings are made large compared to the resistor across which they are connected the loading may be kept within acceptable limits. The values given in Figure 9(a) assumed a 20:1 ratio. Twenty-seven resistors are required.

#### 4.2.3.3.2 A Constant Current Source and Binary Coded Resistors

The circuit of 9(b) is another way to generate the required staircase. In this case, a constant current source injects current into a resistor string which is weighted according to some binary code, for example the 8-4-2-1 binary coded decimal system. Using such a scheme, four resistors are required per decade change in output voltage. The switching for this circuit is arranged so that a resistor is shorted when a binary zero (0) is required, and unshorted when a binary one (1) is needed. The chart of Figure 9(b) shows how the switching must be accomplished.

The major problems with this technique are obtaining a true constant current source<sup>3</sup> and the additive component tolerance since all the resistors are in series. Drift with temperature is additive also.

#### 4.2.3.3.3 An Operational Amplifier and BDC Resistors

The voltage analogue to the previously described circuit, is shown in Figure 9(c). In this case, a constant voltage source is utilized and weighted resistors

---

<sup>3</sup> See Reference 10.

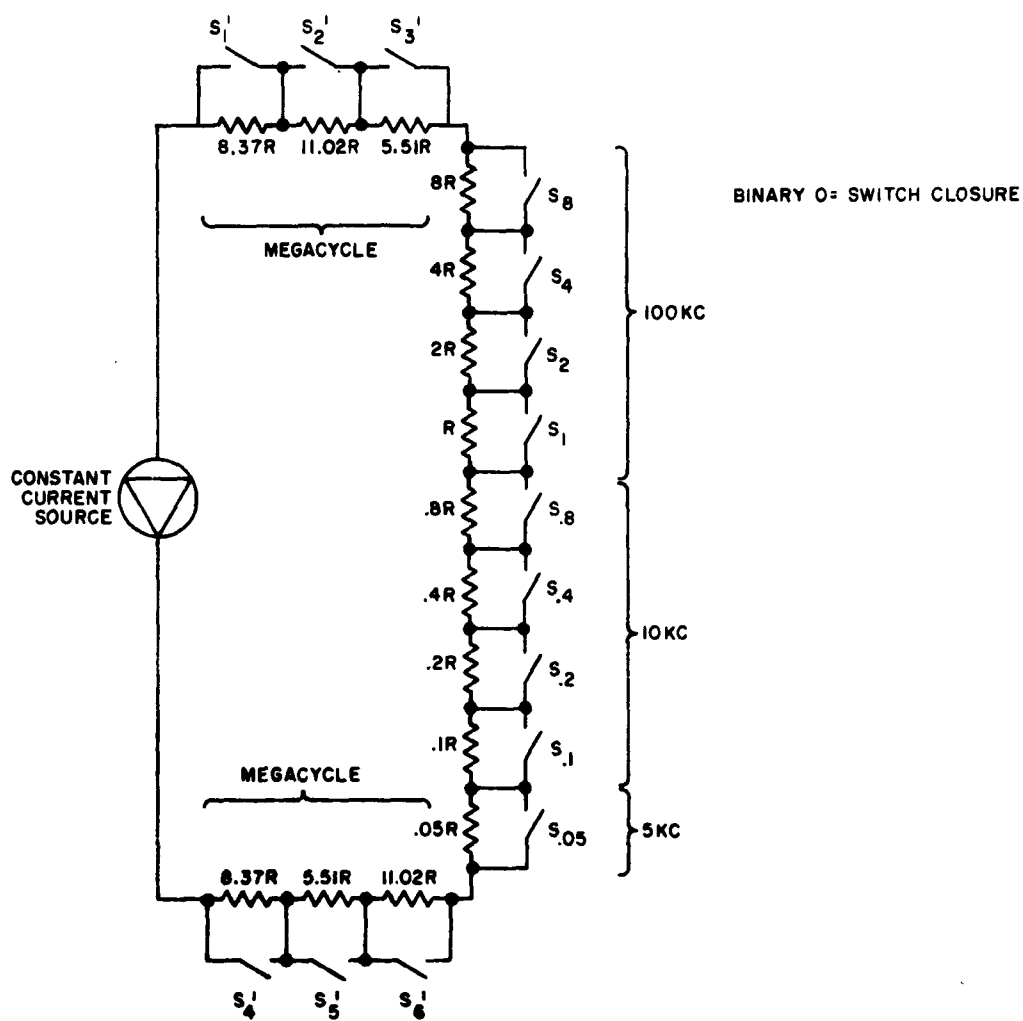

Megacycles						100 KC				10 KC				5 KC		
Digit	S <sub>1</sub> '	S <sub>2</sub> '	S <sub>3</sub> '	S <sub>4</sub> '	S <sub>5</sub> '	S <sub>6</sub> '	Digit	S <sub>8</sub>	S <sub>4</sub>	S <sub>2</sub>	S <sub>1</sub>	S <sub>.8</sub>	S <sub>.4</sub>	S <sub>.2</sub>	S <sub>.1</sub>	S <sub>.05</sub>
3	0	0	0	0	0	0	0	0	0	0	0	0	0	0	0	0
4	0	0	0	0	0	0	1	0	0	0	1	0	0	0	1	0
5	1	0	0	0	0	0	2	0	0	1	0	0	0	1	0	0
6	0	0	0	1	0	0	3	0	0	1	1	0	0	1	1	0
7	1	0	0	0	0	0	4	0	1	0	0	0	1	0	0	0
8	0	0	0	1	0	0	5	0	1	0	1	0	1	0	1	0
9	0	1	0	0	0	0	6	0	1	1	0	0	1	1	0	0
10	0	0	1	0	1	0	7	0	1	1	1	0	1	1	1	0
11	0	0	0	0	0	1	8	1	0	0	0	1	0	0	0	0
							9	1	0	0	1	1	0	0	1	0

Figure 9(b). Constant Current Source Staircase Generator

are switched into both the input and feedback paths of the operational amplifier. The chart on Figure 9(c) tabulates the binary coding of the switches. In this case, a binary 1 indicates a switch closure and a binary 0 a switch open.

The operation of the circuit is straightforward. If the open-loop gain is high, the output voltage from the amplifier is given by

$$E_o = -\frac{R_f}{R_i} E_i$$

where  $R_f$  = feedback resistor

$R_i$  = input resistor

The weighting of the resistors in an 8-4-2-1 code enables the circuit to operate over a decade range by using parallel combinations of the four resistors. The values for the feedback resistor change the gain of the circuit and therefore the output vs. input slope. A few quick calculations will show that the curves of Figure 8(b) are generated when the various switches are closed, and the switches, of course, are controlled by the digital frequency knobs.

This circuit is somewhat more versatile than the one previously described in that gain may be realized when going through the operational amplifier. Some added complexity in the form of a high gain stable DC amplifier is required however.

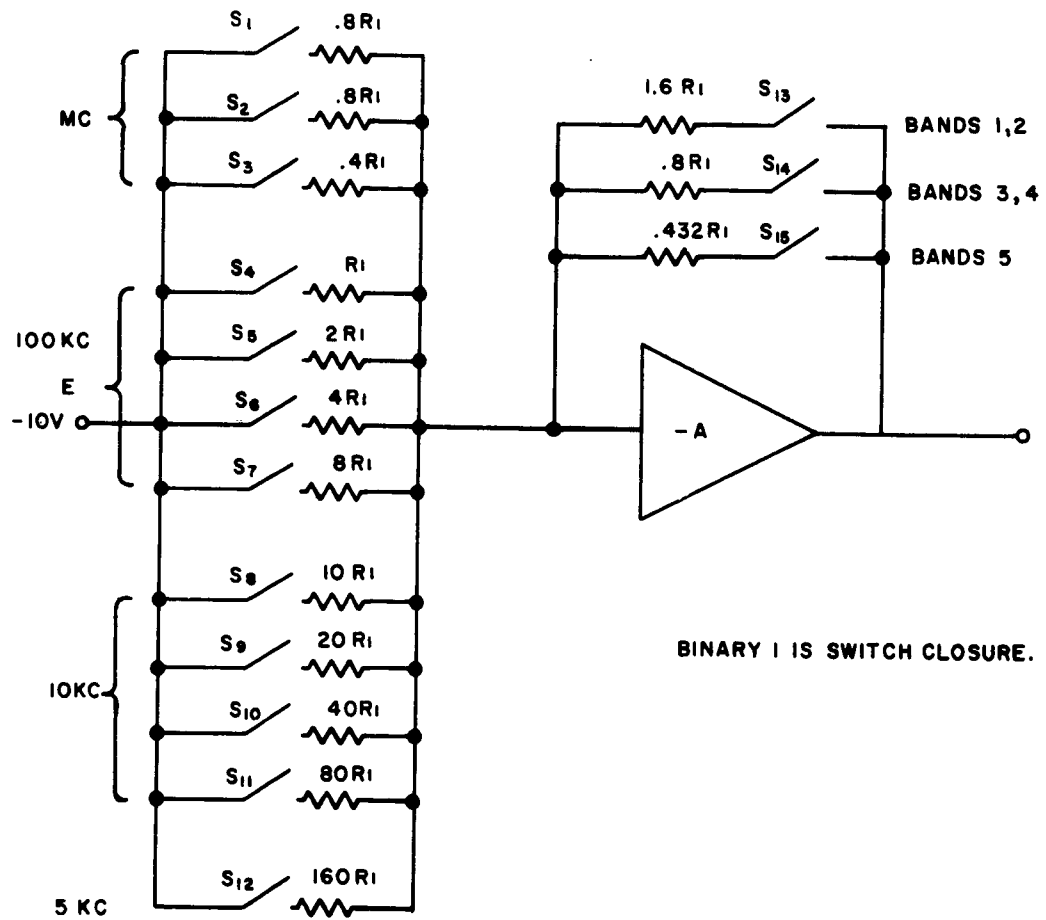

Digit	Megacycles						Digit	100 KC				10 KC				5 KC
	S <sub>1</sub> '	S <sub>2</sub> '	S <sub>3</sub> '	S <sub>4</sub> '	S <sub>5</sub> '	S <sub>6</sub> '		S <sub>8</sub>	S <sub>4</sub>	S <sub>2</sub>	S <sub>1</sub>	S <sub>.8</sub>	S <sub>.4</sub>	S <sub>.2</sub>	S <sub>.1</sub>	
3	0	0	0	0	0	0	0	0	0	0	0	0	0	0	0	0
4	0	0	0	0	0	0	1	0	0	0	1	0	0	0	1	
5	1	0	0	0	0	0	2	0	0	1	0	0	0	1	0	
6	0	0	0	1	0	0	3	0	0	1	1	0	0	1	1	
7	1	0	0	0	0	0	4	0	1	0	0	0	1	0	0	
8	0	0	0	1	0	0	5	0	1	0	1	0	1	0	1	
9	0	1	0	0	0	0	6	0	1	1	0	0	1	1	0	
10	0	0	1	0	1	0	7	0	1	1	1	0	1	1	1	

Figure 9(c). Operational Amplifier Staircase Generator



### 4.3 Packaging of the RF Amplifier

#### 4.3.1 General

The packaging of the Development Models involved a number of compromises which may be of interest. When the decision to side-step the operating temperature specification was made, thereby, allowing the use of high  $\mu$  ferrites with relatively poor temperature coefficients, a concerted effort was made to achieve the maximum package density. Micro-miniature components, such as the pellet and RCA Micro-Module types were specifically excluded from this program and it was, therefore, to be a problem in achieving the best possible compromises with the more or less "standard" types of component. Experiments with various diode and switching arrangements showed that the loaded Q of the tuned RF circuits was degraded too severely to allow their use so mechanical band switching was necessary. With five bands required, it was decided that a turret arrangement would minimize the volume required to enclose the require number of components. Several sketches were made and the minimum package size resulted when the coils and trimmers for the tuned circuits were mounted on special wafer sections, and the amplifier, oscillator and mixer circuits were curved around them.

Figure 10 shows a sketch of the packaging concept at its inception. The coils for the five tuned circuits were to be mounted on the five wafer discs, and there would be five coils per disc, one for each of the bands. Mounted inside semi-circular hinged covers would be the amplifier oscillator and mixer circuits. The hinged covers would allow access to the interior portions and tremendously simplify construction and testing of the unit. The models very closely resemble this first sketch, and the next section points out some features of the individual sub-modules.

#### 4.3.2 The Sub-Modules

Figure 11 is a photograph of the amplifier and oscillator sub-modules

The two pieces in the right half of the photo are the 1st and 2nd RF amplifier sub-modules. The other piece is the local oscillator.

Cordwood packaging has been used throughout and rather high packaging densities (in excess of 60 percent) have been achieved. A brief rundown on this method of packaging follows: a large scale drawing of the component layout is made, reduced, and the plastic end plates printed photographically. Holes for the component leads are drilled in the endplates, and nickle ribbon conductors welded to the component leads. Welding the leads is quite an art and is discussed in Reference 7.

Figure 12 shows the mixer sub-module in the upper part of the photo, and the two halves of the double-tuned input in the lower part.

Figure 13 shows a wafer disc with the switched components from one tuned circuit mounted in place. The dark grid work is the copper showing through from the opposite side. National Vulcanized Fibre .018 Phenolite with .0014 copper was used for making the wafers. Because the material was so thin, the ground plane on the back side was broken up in order to minimize the tendency to warp which results from unequal amounts of copper on the discs. A reduction in stray capacitance to ground was also realized.

Figure 14 shows the hinged cover with the amplifier and oscillator modules mounted in place.

Figure 15 is the other cover containing the double tuned input and the mixer circuit.

Figure 16 shows a view of the stator blocks and the switch contacts. These contacts mate with the printed pattern on the edge of the wafer discs. Excellent wear and low contact resistance are maintained by using silver-alloy contacts in the stator blocks and by nickle plating the wafer discs. A rhodium flash covers the nickle to prevent corrosion with age.

Figure 17 is a view of the mechanical components of the amplifier without the modules in place. The method of hinging the covers is shown as is the shielded compartments into which the sub-modules are mounted.

At the time of this writing, a completely wired unit was not available and so photographs of the complete assembly are not shown.



Figure 11. Oscillator and Amplifier Sub-Modules

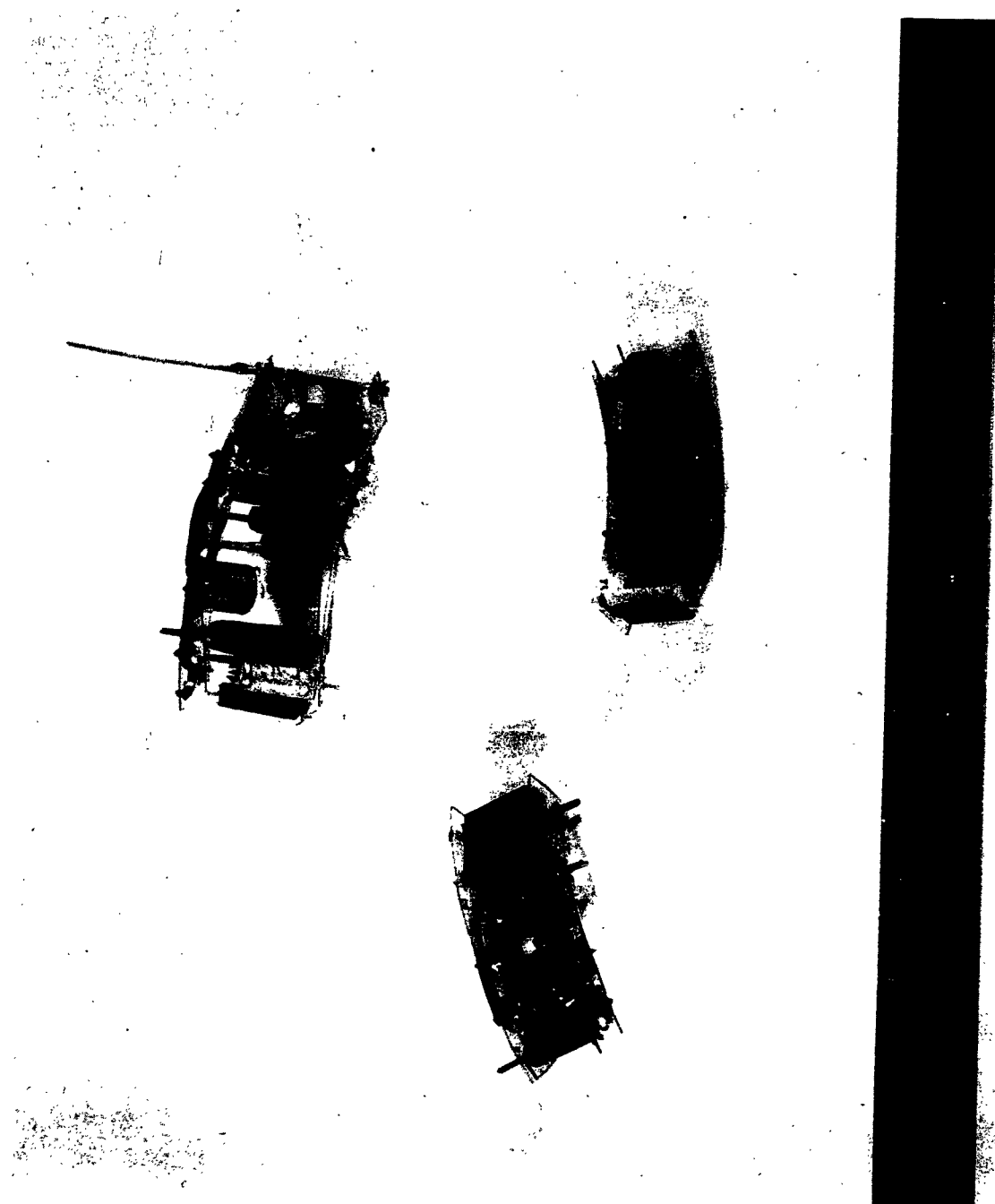

Figure 12. Input Circuit and Mixer Sub-Modules

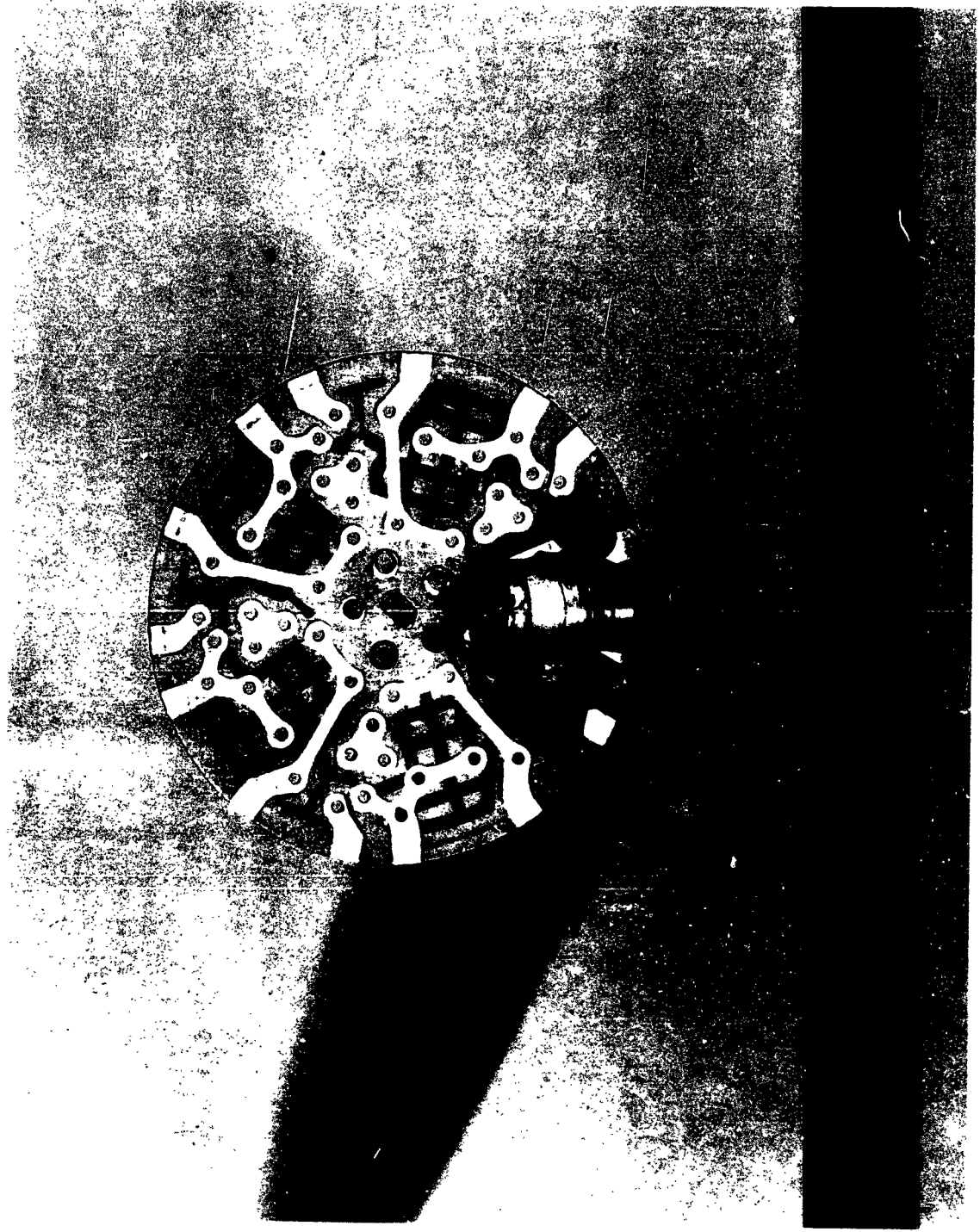

Figure 13. Rotor Wafer Subassembly, Showing One Switched Tank Circuit

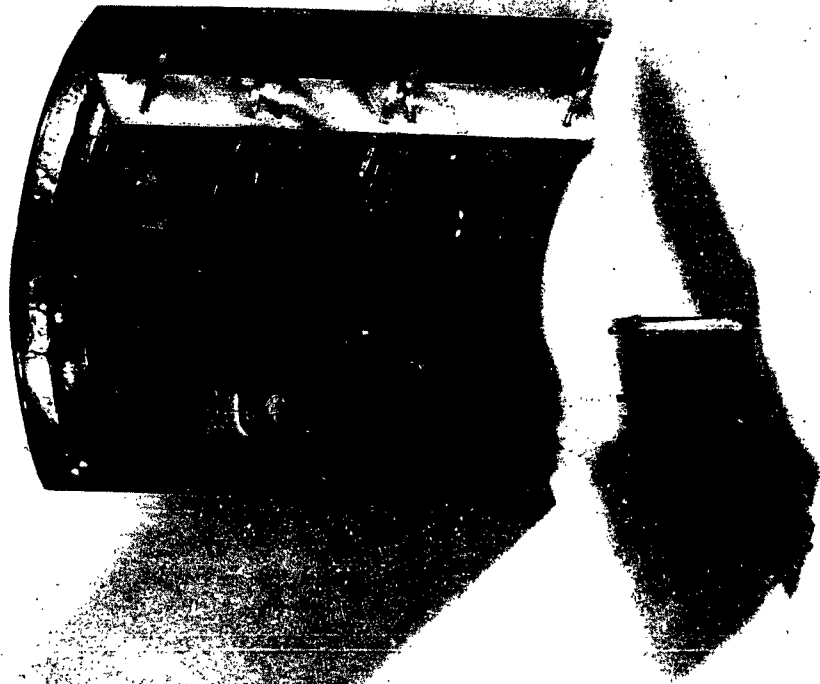

Figure 14. Hinged Cover With Amplifier and Oscillator Sub-Modules Mounted

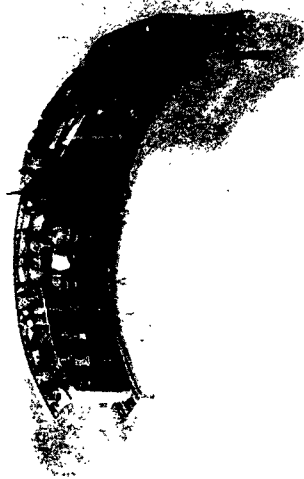
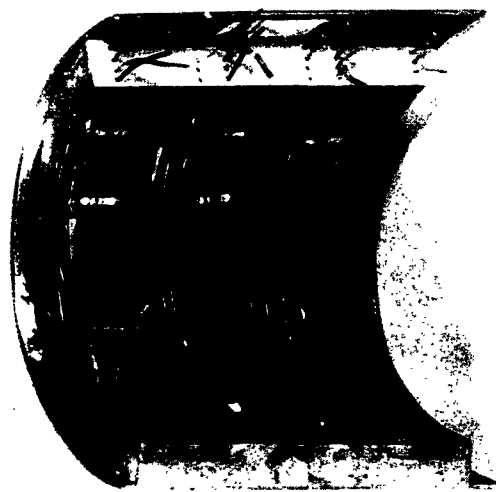

Figure 15. Hinged Cover With Input Circuit and Mixer Sub-Modules

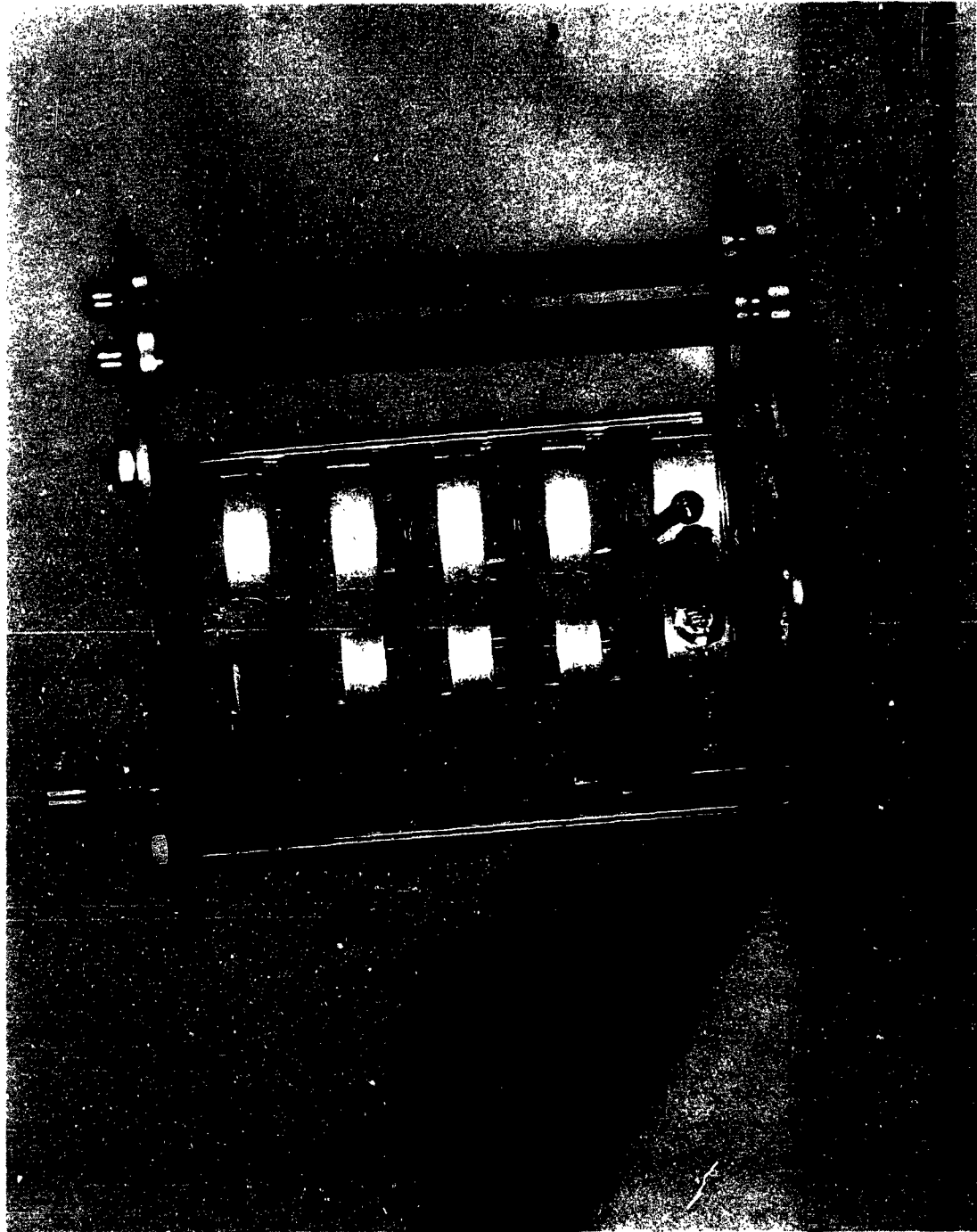

Figure 16. View Showing Inside Stator Block Assembly

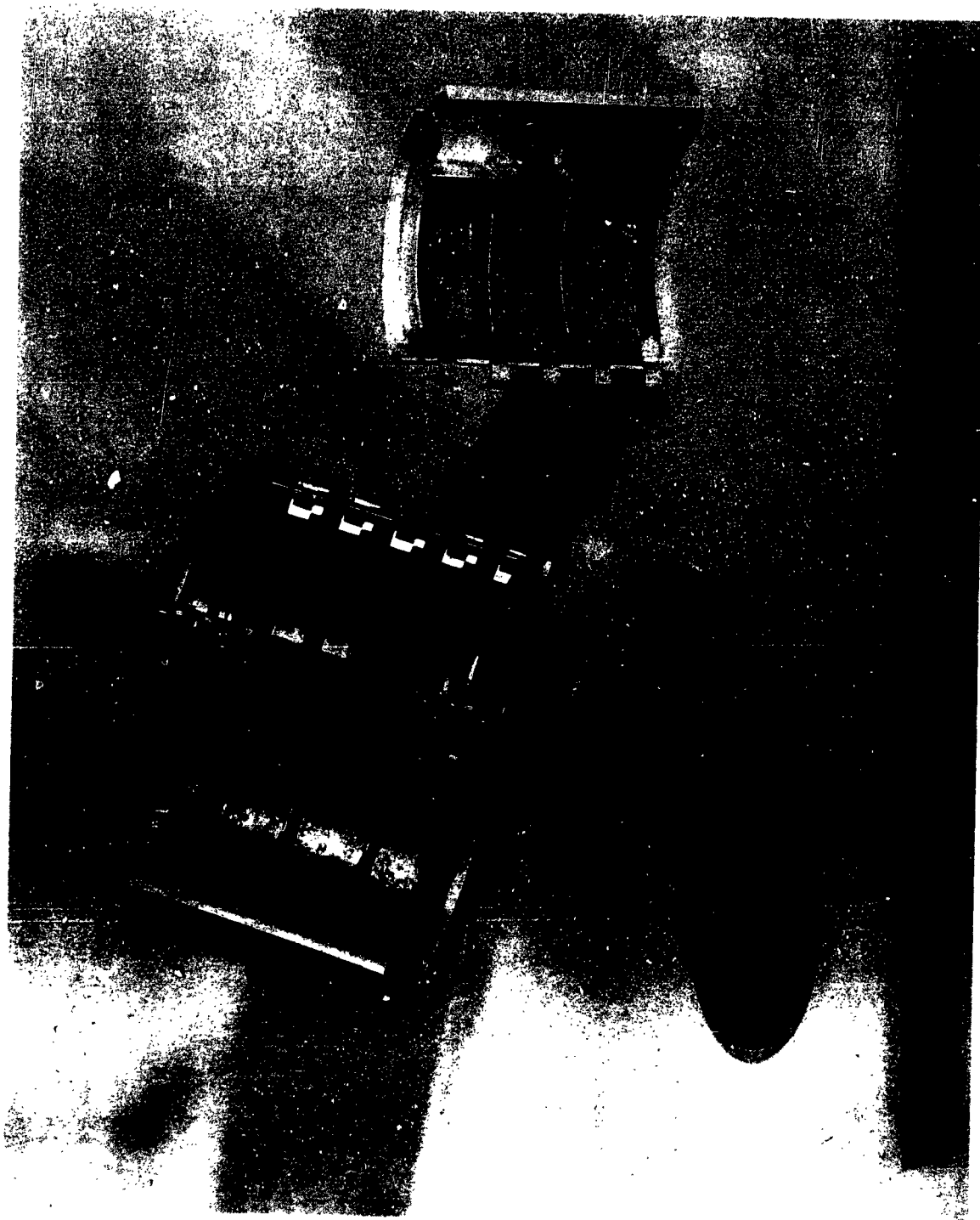

Figure 17. View Showing Hinged Covers and Stator Assembly

## 5. CONCLUSION

A discussion of a variety of methods of obtaining a coarse tuning voltage for tuning the RF amplifier in digital steps has been given. Advantages and disadvantages of the various circuits have been brought out and circuit diagrams with normalized component values presented.

In general, the less sophisticated techniques are limited in accuracy or require a large number of components. The reliability of those circuits should be reasonably high though. The more accurate techniques render improved performance but at the price of circuit complexity.

The diodes shaping circuit with a linear staircase voltage vs. frequency generator appears to offer as good method of obtaining an accurate and reliable coarse tuning voltage curve. Final data on the operation of such a combination will be presented in the final test data on the Development Models.

Concerning the packaging, the cordwood technique certainly achieves high component density, but the construction is quite expensive and repair or maintenance would almost certainly have to be based on a "throw-away" concept since components on the interior of a sub-module are virtually impossible to replace.

6. PROGRAM FOR NEXT INTERVAL

Effort during the next interval will be concentrated exclusively on completion of construction and testing of the Development Model.

7. IDENTIFICATION OF KEY PERSONNEL

The following personnel spent time in execution of the work described in this report.

F. S. J. Daniel	Section Head	23 hours
G. J. Lohowy	Project Engineer	432 hours
J. P. Vidal	Mechanical Designer	518 hours
W. M. Peck	Technician	464 hours
Tech. Illustrators		43 hours
Model Shop		180 hours

8. ACKNOWLEDGEMENTS

Acknowledgements are due to Mr. Joseph Stillwater for his helpful suggestions and criticisms of the work involving coded staircase generators, shaping circuits, and operational amplifiers.

9. ADDENDUM TO THE FOURTH QUARTERLY REPORT

Listed below is a record of Telephone Conversations which was inadvertently left out of the "Conferences" Section of the 4th Quarterly Report.

3.7 Telephone Conversation with Indiana General Corporation Sales Engineer, Keasley, New Jersey on 28 August 1962

A telephone call was made to Messr's Swauger and Palbot of Indiana General Corporation for information on the temperature coefficient vs. air gap on toroids made of Ferramic Q1 and Ferramic Q2 material. Gapping the toroid was not recommended.

The CF201 and CF202 cup cores are made of Q1 and Q2 material on special order. The cup core was recommended if an air gap was desirable

3.8 Telephone Conversation with USAERDL, Ft. Monmouth, New Jersey on 17 September 1962

Mr. R. Tilton was called to determine the status of the contractual change in the number of Deliverable Models required. Mr. Tilton said this change was in process.

Concerning ferrite materials which might be usable for the tuning coils, Mr. Tilton suggested calling General Ceramics about the TC-4 and TC-5 materials. These materials were believed to have a range of 20 different permeabilities and temperature coefficients.

3.9 Telephone Conversation with Indiana General Corporation Engineering Department on 20 September 1962

Mr. Eisenberg was called regarding specifications and characteristics of the TC-4 and TC-5 materials. The TC-4 material was considered usable up to 15 mc. The temperature coefficient of the material in a toroid form was 450 ppm/ $^{\circ}$ C over the range  $-55^{\circ}$ C to  $+75^{\circ}$ C. Samples of the material were being prepared in cup cores approximately 0.6 inch outside diameter. A bobbin and sleeve arrangement which can be tuned is available. The O.D. of the sleeve is 0.3 inch and a plastic holder must be used to cover the sleeve and bobbin.

3.10 Telephone Conversation with Indiana General Corporation Engineering Department on 26 September 1962

During a conversation with Mr. Joseph Venerus, a Product Sales Engineer, the following information was obtained on the TC-4 material.

	5 mc	10 mc	
Q	180 to 190	70 to 80	
$\mu_0$	95 to 100	110 to 115	
Temp. Coeff.	$\approx 400$ ppm/ $^{\circ}$ C	$\approx 400$ ppm/ $^{\circ}$ C	$-65^{\circ}$ C to $+150^{\circ}$ C

Mr. Venerus suggested a copy of Report on ferrite development for contract No. DA-36-039 SC-85234, DA Project 3-39-01-701, Ferrite Development Report No. 51 be obtained. It is the final report on the development of the TC-4 material.

Samples of the material and pricing and delivery information were to be sent to G. Lohwy.

3.11 Telephone Conversation with USAERDL, Ft. Monmouth, New Jersey on 26 September 1962

A call was placed to Mr. R. Tilton and a summary of the talk with Mr. Venerus of Indiana General Corporation was given to him. Because the Q of the temperature compensated TC-4 material was only 80 to 90 at 10 mc it was agreed that the material would not be usable for the present version of the Precision Integrated Tuner. It was further agreed that the poor temperature coefficient of some other high-Q ferrites would be ignored in order to take advantage of the much smaller physical size coils which would be obtained. It was felt that with the present advances being made in ferrite technology, a suitable material would soon become available and that the temperature problem could be tackled then.

## BIBLIOGRAPHY

1. Linearizing Wide Deviation FM Oscillators, Richard A. Dye, *Electronic Equipment Engineering*, April 1961, pp. 72-74.
2. Smooth Curve Function Generation Using Diodes, Joseph J. Stone, ASTIA Report AD 83976.
3. An Arbitrary Function Generator Employing Silicon Diodes and an AC Shaping Signal, A. Laws, Technical Note No. G.W. 559, September 1960, Royal Aircraft Establishment (Farnborough), (available from ASTIA, No. 246935).
4. Notes on Logarithmic Network Design, Dr. Harold Goldberg and Samuel L. Fagin, National Conference Proceedings; Aeronautical and Navigation Electronics; Dayton IRE, 1956, pp. 585 to 597.
5. Non-Linearities In Potentiometer Circuits, R.E. Post and J. Zdzieborski, *Electrical Design News*, March 1959.
6. Analog Computer Techniques, Clarence L. Johnson, McGraw Hill Book Company, 1956.
7. An Introduction to Welded Module Packaging, J. Frank Weatherman. Hughes Aircraft Co. Technical Publication, Vacuum Tube Prod. Div., 2020 Short Street, Oceanside, California.
8. Wave Generation and Shaping, Leonard Strauss, McGraw Hill Book Co. Inc., New York, 1960.
9. Two Transistors Equal One Constant Current Drive, G. Watson, *Electronics*, 6 July 1962.

<p>AD- Div 5/28 8/2</p> <p>General Dynamics/Electronics, Rochester, N. Y.</p> <p>INTEGRATED PRECISION TUNING SYSTEM by G. Luhowy</p> <p>Rept. for:</p> <p>(SCTR NO. SCL-7566A (11 Jan 61) DA NO 3D26-02-001)</p> <p>(Contract No DA-36-039-SC-88904) Unclassified report</p> <p>2 <u>ABSTRACT</u></p> <p>2.1 <u>Generation of the Digital Tuning Voltage</u></p> <p>A number of techniques for generating the digitally controlled coarse tuning voltage are discussed. Several circuits are investigated and the results are presented. Advantages and disadvantages of the various techniques are pointed out.</p> <p>2.2 <u>Packaging of the Development Models</u></p> <p>A brief discussion of the packaging techniques used to construct the Development Models is given. Photographs and assembly drawings are presented in order to emphasize salient features</p> <p>(U C T)</p>	<p>UNCLASSIFIED</p> <p>1. Tuning devices</p> <p>2. Capacitor, voltage variable</p> <p>I. Title: Precision Tuning</p> <p>II. Luhowy, G.</p> <p>III. Army Signal Research and Development Lab.</p> <p>Fort Monmouth, N. J.</p> <p>IV. Contract DA No. 3D26-02-001</p> <p>Armed Services Technical Information Agency UNCLASSIFIED</p>	<p>AD- Div 5/28 8/2</p> <p>General Dynamics/Electronics, Rochester, N. Y.</p> <p>INTEGRATED PRECISION TUNING SYSTEM by G. Luhowy</p> <p>Rept. for:</p> <p>(SCTR NO. SCL-7566A (11 Jan 61) DA NO 3D26-02-001)</p> <p>(Contract No DA-36-039-SC-88904) Unclassified report</p> <p>2 <u>ABSTRACT</u></p> <p>2.1 <u>Generation of the Digital Tuning Voltage</u></p> <p>A number of techniques for generating the digitally controlled coarse tuning voltage are discussed. Several circuits are investigated and the results are presented. Advantages and disadvantages of the various techniques are pointed out.</p> <p>2.2 <u>Packaging of the Development Models</u></p> <p>A brief discussion of the packaging techniques used to construct the Development Models is given. Photographs and assembly drawings are presented in order to emphasize salient features</p> <p>(U C T)</p>	<p>UNCLASSIFIED</p> <p>1. Tuning devices</p> <p>2. Capacitor, voltage variable</p> <p>I. Title: Precision Tuning</p> <p>II. Luhowy, G.</p> <p>III. Army Signal Research and Development Lab.</p> <p>Fort Monmouth, N. J.</p> <p>IV. Contract DA No. 3D26-02-001</p> <p>Armed Services Technical Information Agency UNCLASSIFIED</p>
---	---	---	---

<p>AD- Div 5/28 8/2</p> <p>General Dynamics/Electronics, Rochester, N. Y.</p> <p>INTEGRATED PRECISION TUNING SYSTEM by G. Luhowy</p> <p>Rept. for:</p> <p>(SCTR NO. SCL-7566A (11 Jan 61) DA NO 3D26-02-001)</p> <p>(Contract No DA-36-039-SC-88904) Unclassified report</p> <p>2 <u>ABSTRACT</u></p> <p>2.1 <u>Generation of the Digital Tuning Voltage</u></p> <p>A number of techniques for generating the digitally controlled coarse tuning voltage are discussed. Several circuits are investigated and the results are presented. Advantages and disadvantages of the various techniques are pointed out.</p> <p>2.2 <u>Packaging of the Development Models</u></p> <p>A brief discussion of the packaging techniques used to construct the Development Models is given. Photographs and assembly drawings are presented in order to emphasize salient features</p> <p>(U C T)</p>	<p>UNCLASSIFIED</p> <p>1. Tuning devices</p> <p>2. Capacitor, voltage variable</p> <p>I. Title: Precision Tuning</p> <p>II. Luhowy, G.</p> <p>III. Army Signal Research and Development Lab.</p> <p>Fort Monmouth, N. J.</p> <p>IV. Contract DA No. 3D26-02-001</p> <p>Armed Services Technical Information Agency UNCLASSIFIED</p>	<p>AD- Div 5/28 8/2</p> <p>General Dynamics/Electronics, Rochester, N. Y.</p> <p>INTEGRATED PRECISION TUNING SYSTEM by G. Luhowy</p> <p>Rept. for:</p> <p>(SCTR NO. SCL-7566A (11 Jan 61) DA NO 3D26-02-001)</p> <p>(Contract No DA-36-039-SC-88904) Unclassified report</p> <p>2 <u>ABSTRACT</u></p> <p>2.1 <u>Generation of the Digital Tuning Voltage</u></p> <p>A number of techniques for generating the digitally controlled coarse tuning voltage are discussed. Several circuits are investigated and the results are presented. Advantages and disadvantages of the various techniques are pointed out.</p> <p>2.2 <u>Packaging of the Development Models</u></p> <p>A brief discussion of the packaging techniques used to construct the Development Models is given. Photographs and assembly drawings are presented in order to emphasize salient features</p> <p>(U C T)</p>	<p>UNCLASSIFIED</p> <p>1. Tuning devices</p> <p>2. Capacitor, voltage variable</p> <p>I. Title: Precision Tuning</p> <p>II. Luhowy, G.</p> <p>III. Army Signal Research and Development Lab.</p> <p>Fort Monmouth, N. J.</p> <p>IV. Contract DA No. 3D26-02-001</p> <p>Armed Services Technical Information Agency UNCLASSIFIED</p>
---	---	---	---

UNCLASSIFIED	UNCLASSIFIED	UNCLASSIFIED	UNCLASSIFIED
UNTERMS Tuning Digital Capacitor-variable Crossmodulation Distortion Tracking Frequency	UNTERMS Tuning Digital Capacitor-variable Crossmodulation Distortion Tracking Frequency	UNTERMS Tuning Digital Capacitor-variable Crossmodulation Distortion Tracking Frequency	UNTERMS Tuning Digital Capacitor-variable Crossmodulation Distortion Tracking Frequency

UNCLASSIFIED	UNCLASSIFIED	UNCLASSIFIED	UNCLASSIFIED
UNTERMS Tuning Digital Capacitor-variable Crossmodulation Distortion Tracking Frequency	UNTERMS Tuning Digital Capacitor-variable Crossmodulation Distortion Tracking Frequency	UNTERMS Tuning Digital Capacitor-variable Crossmodulation Distortion Tracking Frequency	UNTERMS Tuning Digital Capacitor-variable Crossmodulation Distortion Tracking Frequency



	<p>UNCLASSIFIED</p> <p>UNITERMS</p> <p>Tuning</p> <p>Digital</p> <p>Capacitor-variable</p> <p>Crossmodulation</p> <p>Distortion</p> <p>Tracking</p> <p>Frequency</p> <p>UNCLASSIFIED</p>		<p>UNCLASSIFIED</p> <p>UNITERMS</p> <p>Tuning</p> <p>Digital</p> <p>Capacitor-variable</p> <p>Crossmodulation</p> <p>Distortion</p> <p>Tracking</p> <p>Frequency</p> <p>UNCLASSIFIED</p>
--	--	--	--

	<p>UNCLASSIFIED</p> <p>UNITERMS</p> <p>Tuning</p> <p>Digital</p> <p>Capacitor-variable</p> <p>Crossmodulation</p> <p>Distortion</p> <p>Tracking</p> <p>Frequency</p> <p>UNCLASSIFIED</p>		<p>UNCLASSIFIED</p> <p>UNITERMS</p> <p>Tuning</p> <p>Digital</p> <p>Capacitor-variable</p> <p>Crossmodulation</p> <p>Distortion</p> <p>Tracking</p> <p>Frequency</p> <p>UNCLASSIFIED</p>
--	--	--	--

UNITED STATES ARMY SIGNAL RESEARCH & DEVELOPMENT AGENCY  
STANDARD DISTRIBUTION  
RESEARCH AND DEVELOPMENT CONTRACT REPORTS.

Copies

- 1 Technical Library, OASD (R&E) Rm 3E1065, The Pentagon, Washington 25, D. C.
- 1 Commanding Officer, U. S. Army Signal Research and Development Agency, Fort Monmouth, N. J., ATTN: SIGRA/SL-DE
- 1 Commanding Officer, U. S. Army Signal Research and Development Agency, Fort Monmouth, N. J., ATTN: SIGRA/SL-ADT
- 1 Commanding Officer, U. S. Army Signal Research and Development Agency, Fort Monmouth, N. J., ATTN: SIGRA/SL-ADJ (MF&R Unit #1, EC Dept.)
- 3 Commanding Officer, U. S. Army Signal Research and Development Agency, Fort Monmouth, N. J., ATTN: SIGRA/SL-LNF
- 1 Commanding Officer, U. S. Army Signal Equipment Support Agency, Fort Monmouth, N. J., ATTN: SIGMS/ADJ
- 1 Commanding Officer, U. S. Army Signal Equipment Support Agency, Fort Monmouth, N. J., ATTN: SIGMS/SDM
- 1 Director, U. S. Naval Research Laboratory, Washington 25, D. C., ATTN: Code 2027
- 1 Commanding Officer and Director, U. S. Navy Electronics Laboratory, San Diego 52, California
- 2 U. S. Army Signal Liaison Office, AFDL-9, Wright Aeronautical Systems Command, Building 50, Room 025, Wright Patterson Air Force Base, Ohio
- 1 Commander, Air Force Command and Control Development Division, Air Research and Development Command, United States Air Force, L. G. Hanscom Field, Bedford, Massachusetts, ATTN: CROTLR-2
- 1 Commander, Rome Air Development Center, Air Research and Development Command, ATTN: RCSSLD, Griffiss Air Force Base, New York
- 10 Commander, Armed Services Technical Information Agency, Arlington Hall Station, Arlington 12, Virginia
- 1 Commanding General, Army Ordnance Missile Command Signal Office, Redstone Arsenal, Alabama

- 1 Chief, Bureau of Ships, Dept. of the Navy, Washington 25, D. C.  
ATTN: 691B2C
- 1 Commander, New York Naval Shipyard, Materials Laboratory, Brooklyn, New York, ATTN: Code 910-d
- 1 Commanding Officer, Diamond Ordnance Fuze Laboratories, Washington 25, D. C., ATTN: Technical Reference Section, ORDTL-06.33
- 1 Commanding Officer, Engineering R&D Laboratories, Fort Belvoir, Virginia, ATTN: Technical Documents Center
- 2 Chief, U. S. Army Security Agency, Arlington Hall Station, Arlington 21, Virginia
- 1 Deputy President, U. S. Army Security Agency Board, Arlington Hall Station, Arlington 12, Virginia
- 1 Marine Corps Liaison Officer, U. S. Army Signal Research & Development Lab., Fort Monmouth, N. J., ATTN: SIGRA/SL-LNR
- 2 Advisory Group on Electron Devices, 346 Broadway, New York 13, N. Y.
- 14 Commanding Officer, U. S. Army Signal Research & Development Agency, Fort Monmouth, N. J., ATTN: SIGRA/SL-PEP (Mr. E. S. Tilton)
- 1 U.S. Army Signal Supply Agency, 225 South 18th Street, Philadelphia 3, Pennsylvania, ATTN: SIGSU-R2a (Mr. Thompson)