

UNCLASSIFIED

AD 296 474

*Reproduced
by the*

**ARMED SERVICES TECHNICAL INFORMATION AGENCY
ARLINGTON HALL STATION
ARLINGTON 12, VIRGINIA**



UNCLASSIFIED

NOTICE: When government or other drawings, specifications or other data are used for any purpose other than in connection with a definitely related government procurement operation, the U. S. Government thereby incurs no responsibility, nor any obligation whatsoever; and the fact that the Government may have formulated, furnished, or in any way supplied the said drawings, specifications, or other data is not to be regarded by implication or otherwise as in any manner licensing the holder or any other person or corporation, or conveying any rights or permission to manufacture, use or sell any patented invention that may in any way be related thereto.

296474



DEFENSE RESEARCH LABORATORY



296 474

THE UNIVERSITY OF TEXAS · AUSTIN 12, TEXAS



DRL-490

CF-2990

MODIFYING A DYMEC DY-5304 TIME INTERVAL
RECORDING SYSTEM TO INCREASE ITS DATA
HANDLING CAPABILITY

by

George G. Moore

A Technical Report Prepared under
Bureau of Naval Weapons Contract NOrd-16498
Task UTX-5, Problem UTX-5-A

December 1962

Copy No. 34

DEFENSE RESEARCH LABORATORY
THE UNIVERSITY OF TEXAS
AUSTIN 12, TEXAS

ABSTRACT

- ↓
- Modification of the Dymec DY-5304 Time Interval Counting System at ~~Station~~*Station 002 to provide simultaneous reduction of two channels of doppler data is described.

* doppler tracking

↑

MODIFYING A DYMEC DY-5304 TIME INTERVAL RECORDING SYSTEM
TO INCREASE ITS DATA HANDLING CAPABILITY

by

George G. Moore

INTRODUCTION

Station 002 is a doppler tracking station operated by Defense Research Laboratory under Contract NOrd-16498, Task UTX-5. The contract is under the technical supervision of Applied Physics Laboratory, The Johns Hopkins University, Silver Spring, Maryland.

The data output of the station consists primarily of punched paper tape containing time and frequency information regarding the doppler shift received from ultrastable, coherent, multiple frequency satellites. Two data tapes are punched simultaneously. Each data point consists of 5 digits denoting the time of beginning of a count in seconds and 6 digits of time interval in microseconds, of a preset integral number of cycles of doppler frequency.

Station 002 was furnished by the Applied Physics Laboratory initially with a Dymec DY-5304 Time Interval Counting System capable of digitizing one channel of data (one doppler frequency). The original system is illustrated in Figures 1 and 2. As the tracking program developed more fully, greater capability was needed. As a result of this need, the original Dymec system was modified and enlarged as described further in this report.

DESCRIPTION OF ORIGINAL SYSTEM

The DY-5304 Time Interval Recording System measures the lapsed time between a pair of pulses and simultaneously records this time interval on a digital recorder and on a tape punch. Also recorded simultaneously is the actual time of day in terms of seconds from a selected starting time. In a doppler tracking station, the time between pulses represents an integral number of cycles of

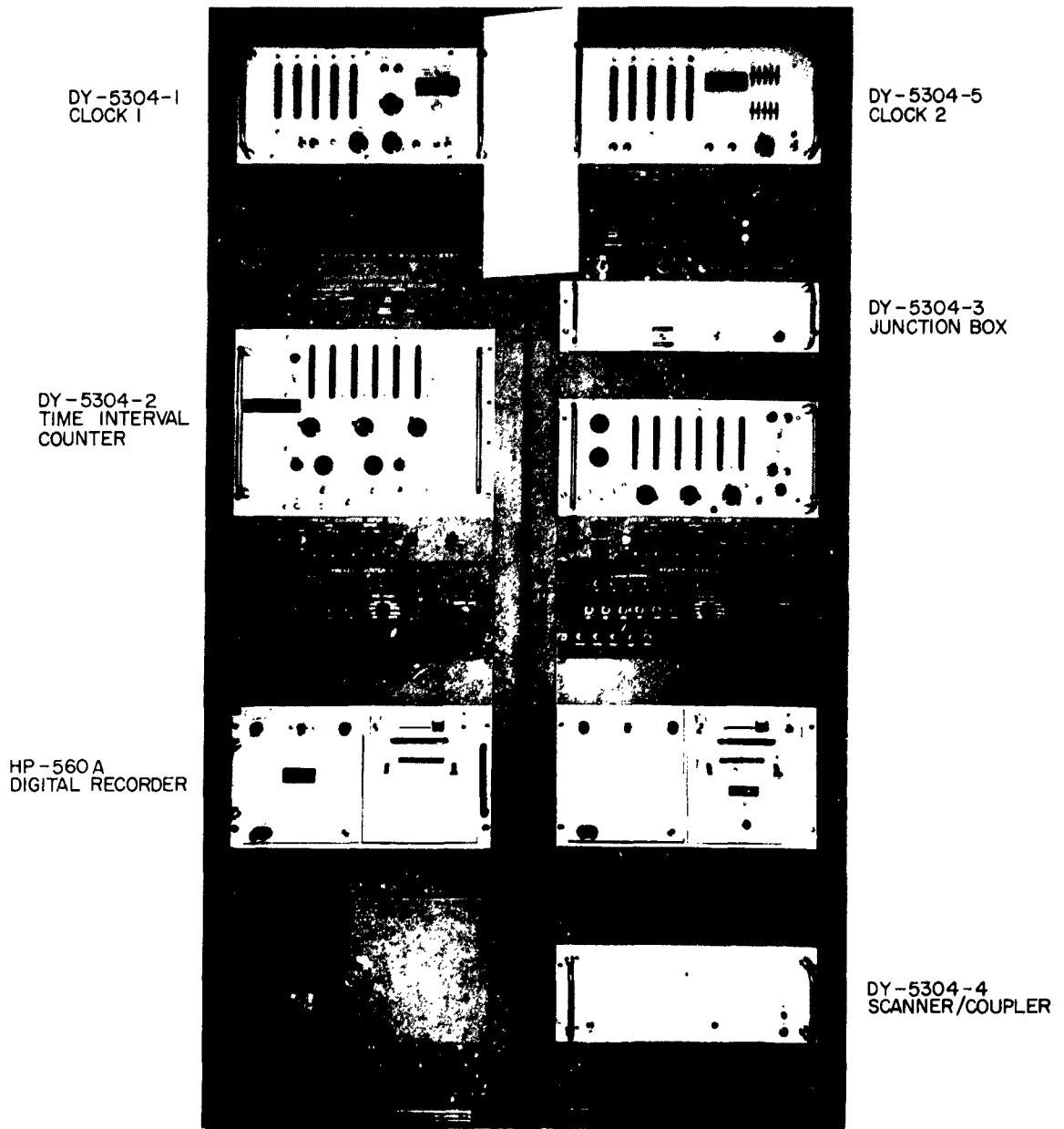

FIGURE 1
ORIGINAL DY-5304 TIME INTERVAL RECORDING SYSTEM

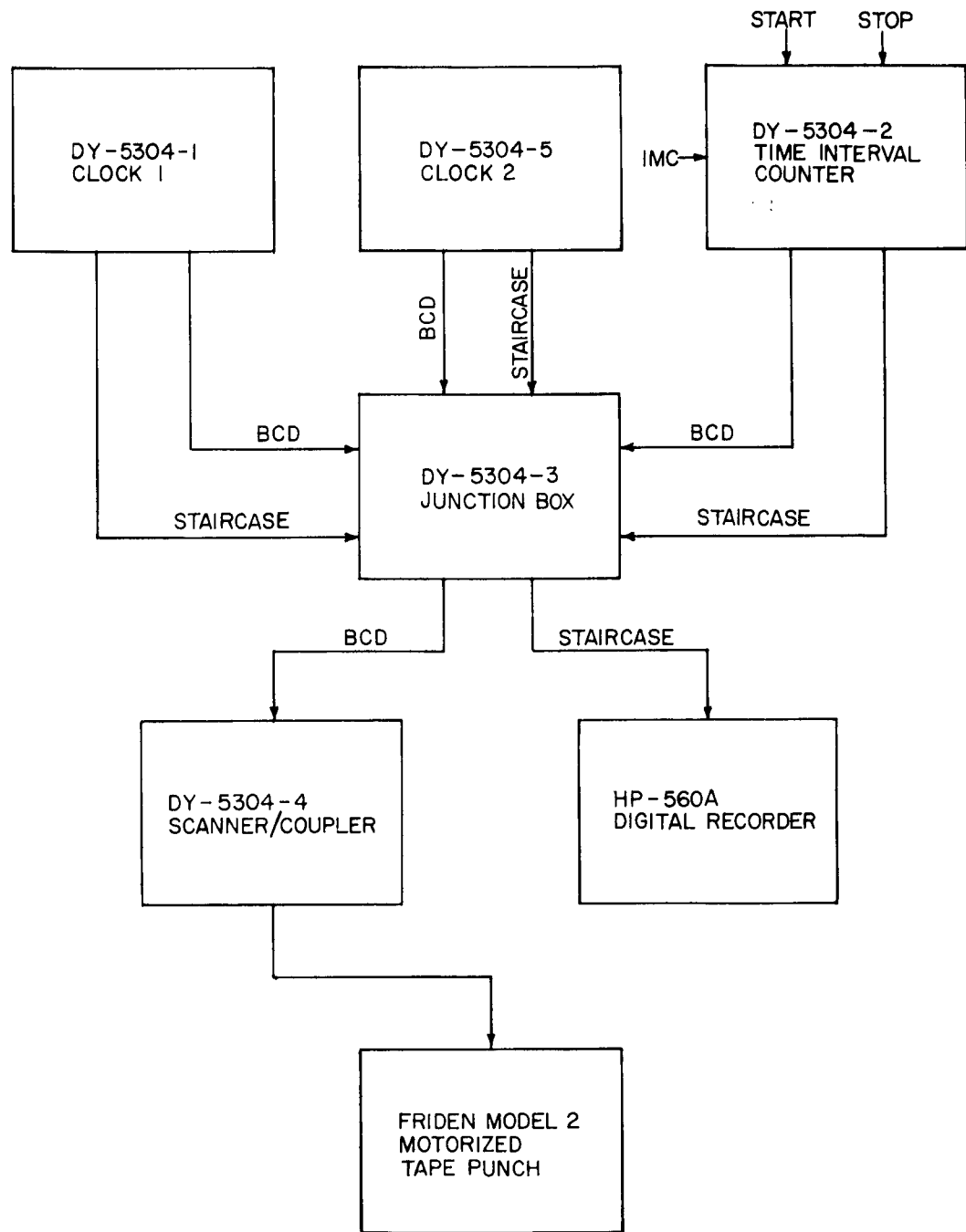

FIGURE 2
ORIGINAL DY-5304 TIME INTERVAL RECORDING SYSTEM

doppler frequency. The DY-5304 system originally consisted of the following instruments:

DY-5304-1	Time Accumulator
DY-5304-2	Time Interval Counter
DY-5304-3	Junction Box
DY-5304-4	Scanner/Coupler
DY-5304-5	Electronic Counter
HP-560 A	Digital Recorder
Friden Model 2	Motorized Tape Punch

The DY-5304-1 time accumulator is denoted as clock #1 and the DY-5304-5 electronic counter is denoted as clock #2. Provision is made for selecting either clock for readout in the junction box. One is used for real time counting and the other for playback counting of seconds referenced to universal time.

At the completion of each time interval count, the time and time interval information are printed automatically on the digital recorder and punched in 5 hole teletype code on the paper tape punch.

For more detailed information regarding this original system, see "DY-5304, Time Interval Recording System," by Dymec Inc., 395 Page Mill Road, Palo Alto, California. Also, see the manuals for the individual units.

DESCRIPTION OF MODIFIED SYSTEM

The modified system is shown in Figures 3 and 4. The equipment additions necessary to increase the system to two-channel capability were:

1 DY-5304-2	Time Interval Counter #2
1 HP-560 A	Digital Recorder #2
1 Friden Model 2	Motorized Tape Punch #2

Extensive modifications were made to the DY-5304-4 scanner/coupler. For the original circuits of the scanner/coupler, refer to "Specification DY-5304-4 Scanner/Coupler," by Dymec Inc., 395 Page Mill Road, Palo Alto, California. Figures 5 and 6 show the circuits of the modified scanner/coupler as illustrated by Figures 7, 8, 9, 10, 11, and 12. Details of the scanner/coupler modifications are given below.

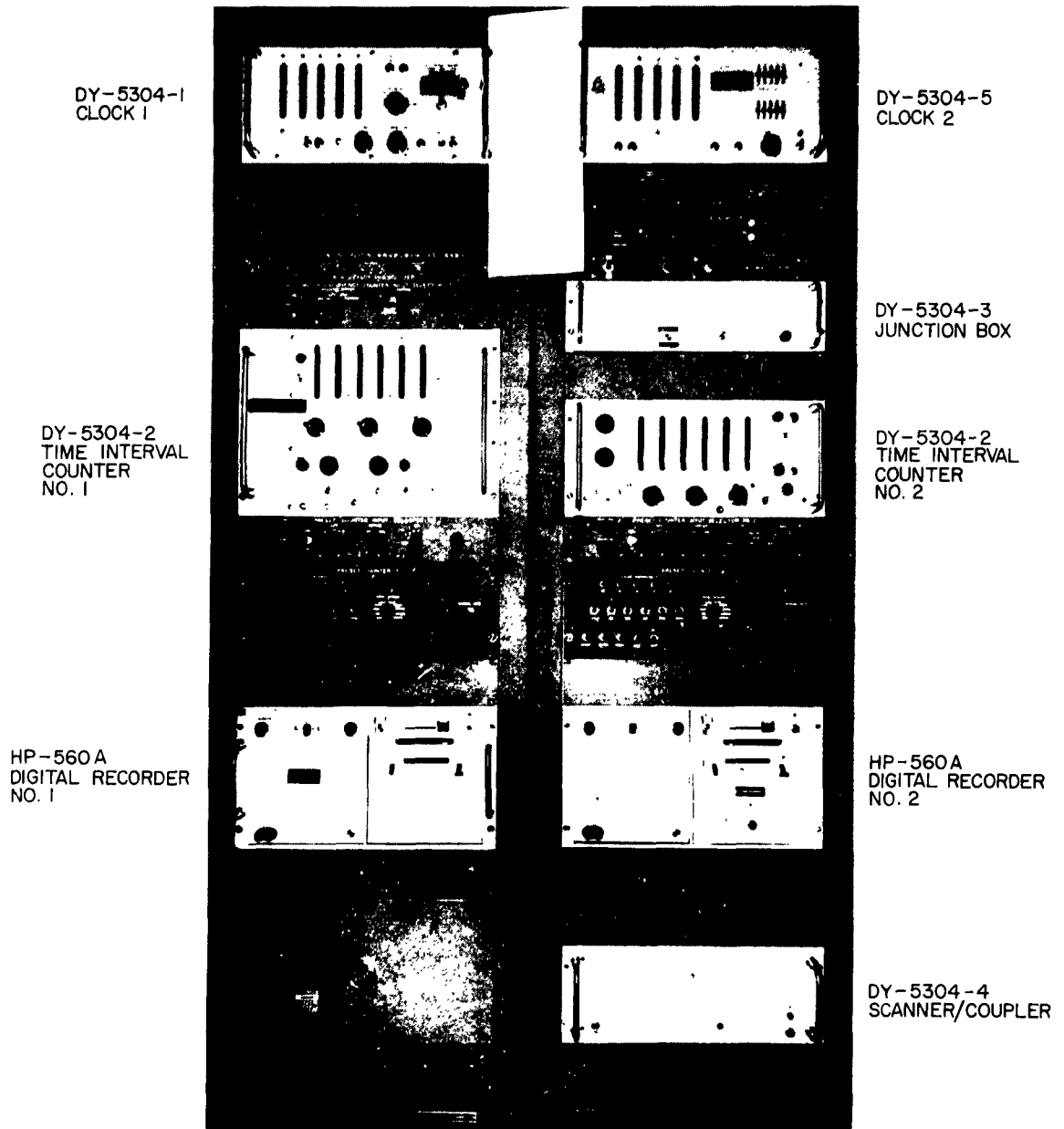

FIGURE 3
MODIFIED DY-5304 TIME INTERVAL RECORDING SYSTEM

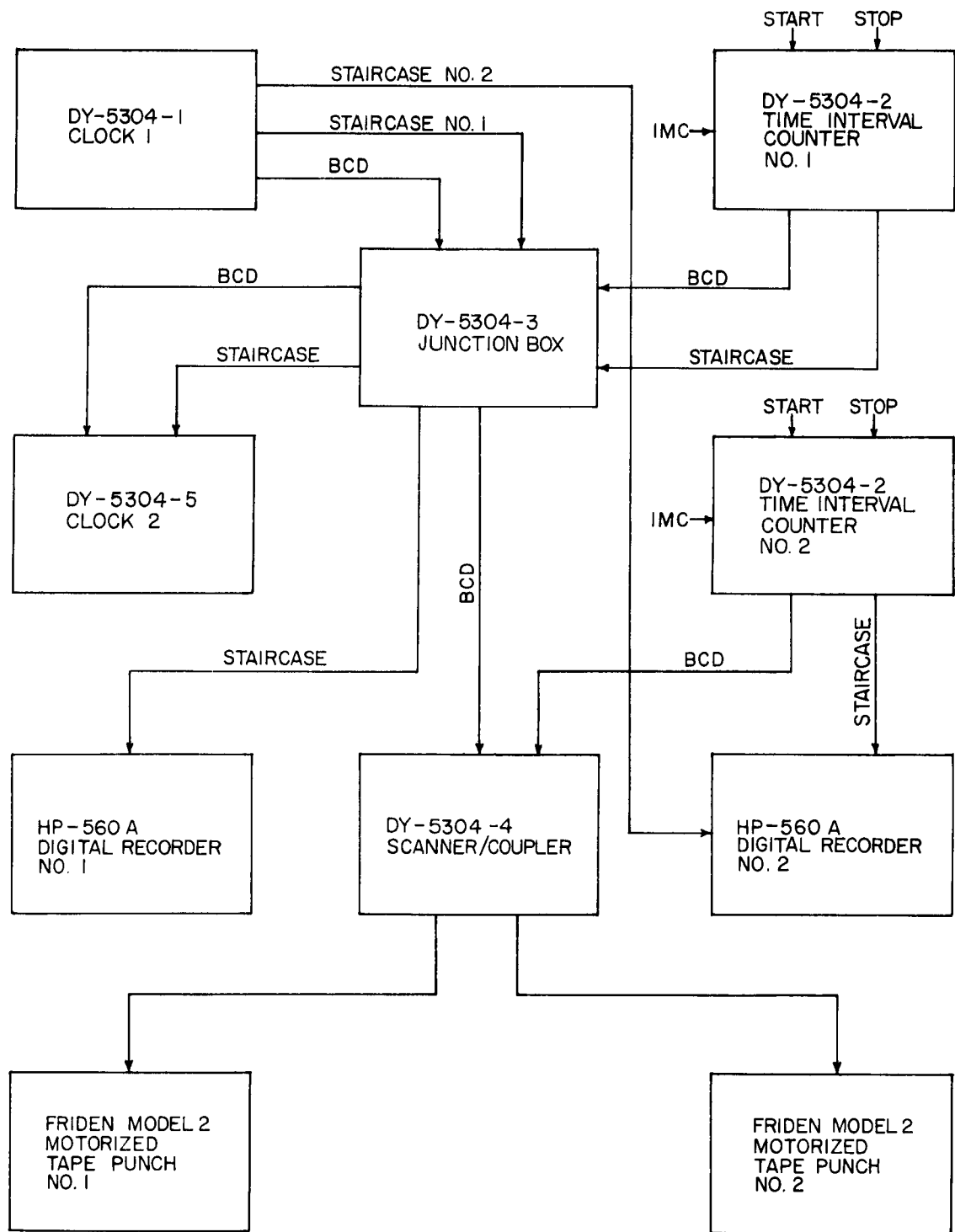
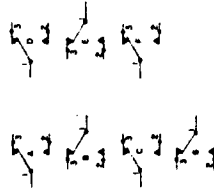
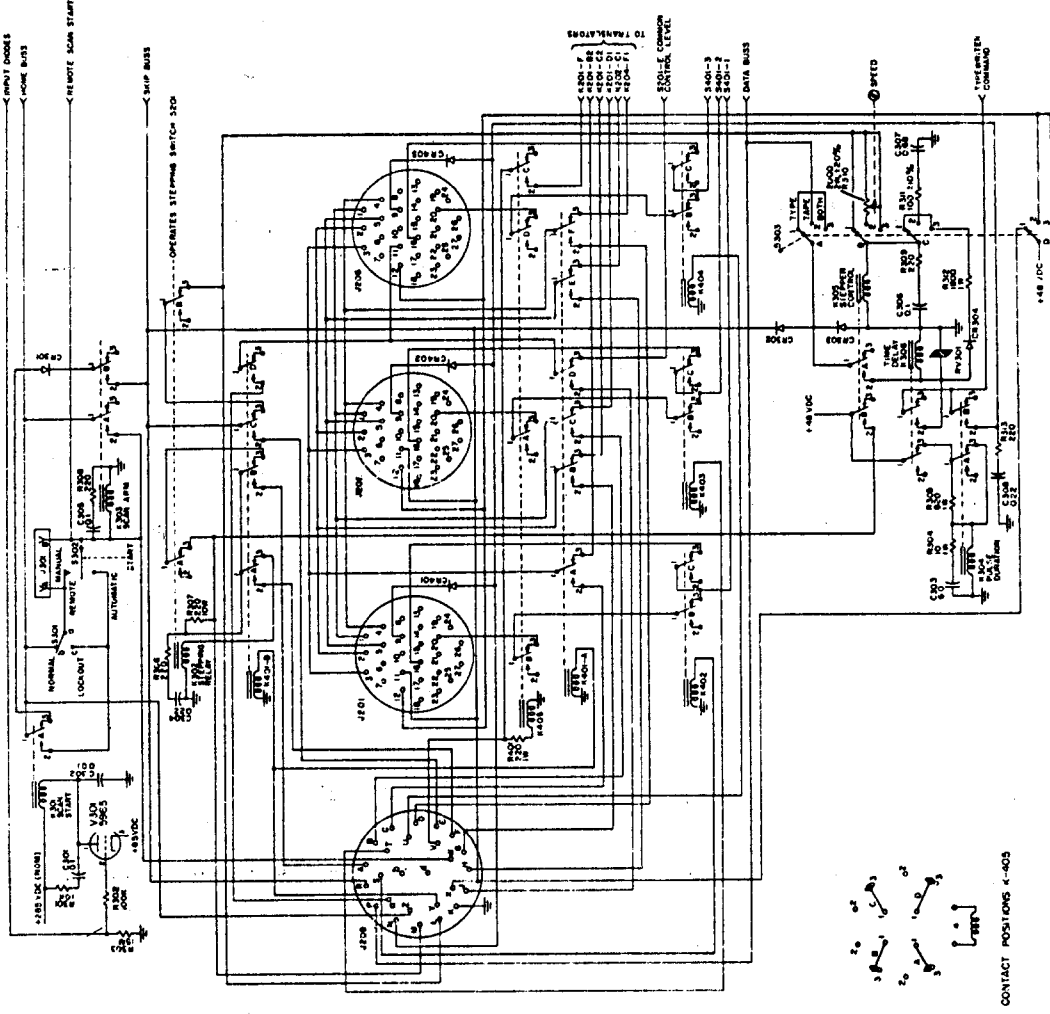
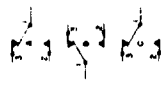

FIGURE 4

MODIFIED DY-5304 TIME INTERVAL RECORDING SYSTEM



CONTACT POSITIONS
OF K-401, K-402, K-403



CONTACT POSITIONS
OF K-402, K-404

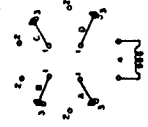

CONTACT POSITIONS K-403

Best Available Copy

FIGURE 5
MODIFIED DYMEC DY-5304-4 SCANNER/COUPLER CONTROL CIRCUITS

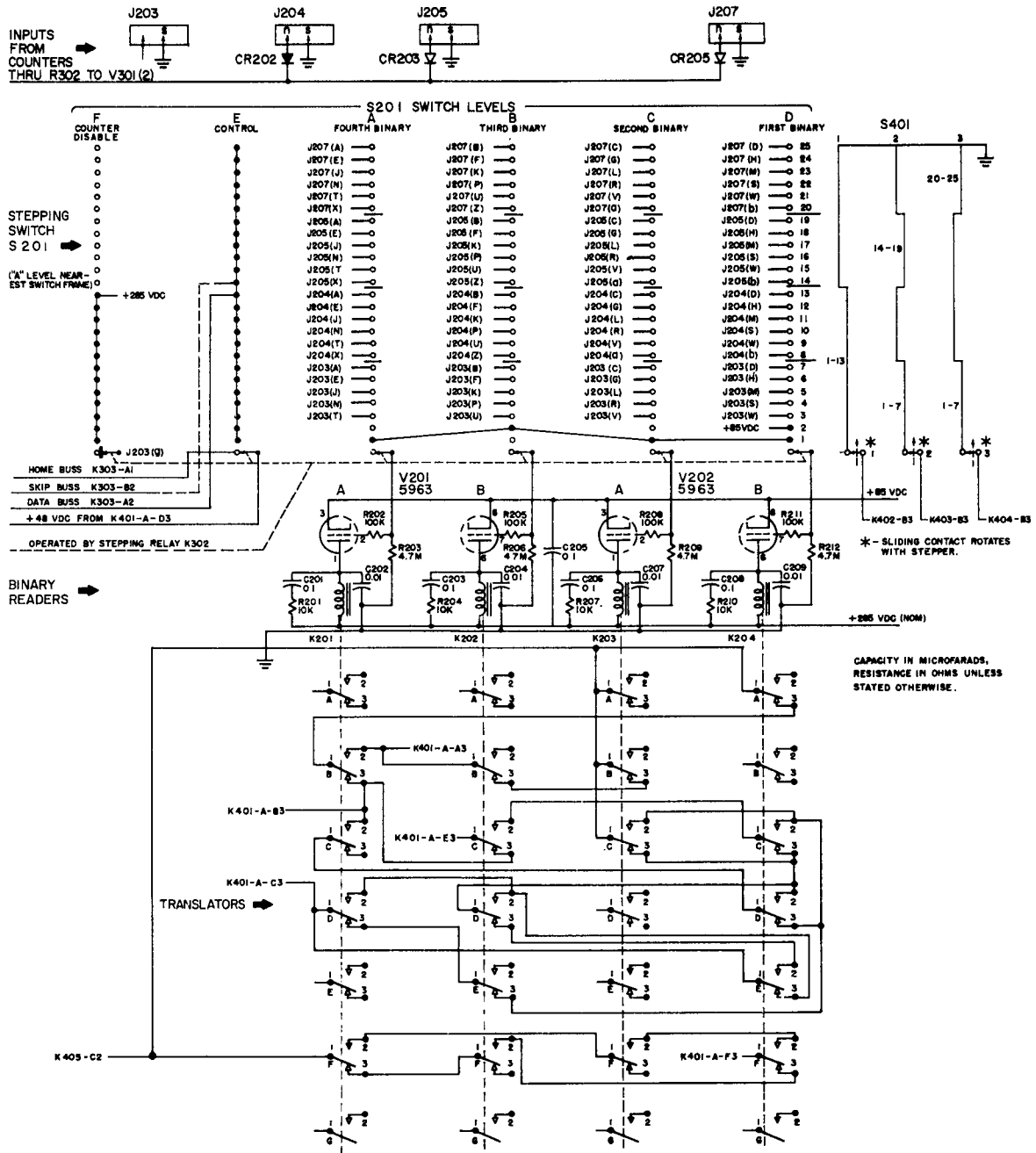

FIGURE 6

MODIFIED DYMEC DY-5304-4 SCANNER COUPLER DATA CIRCUITS

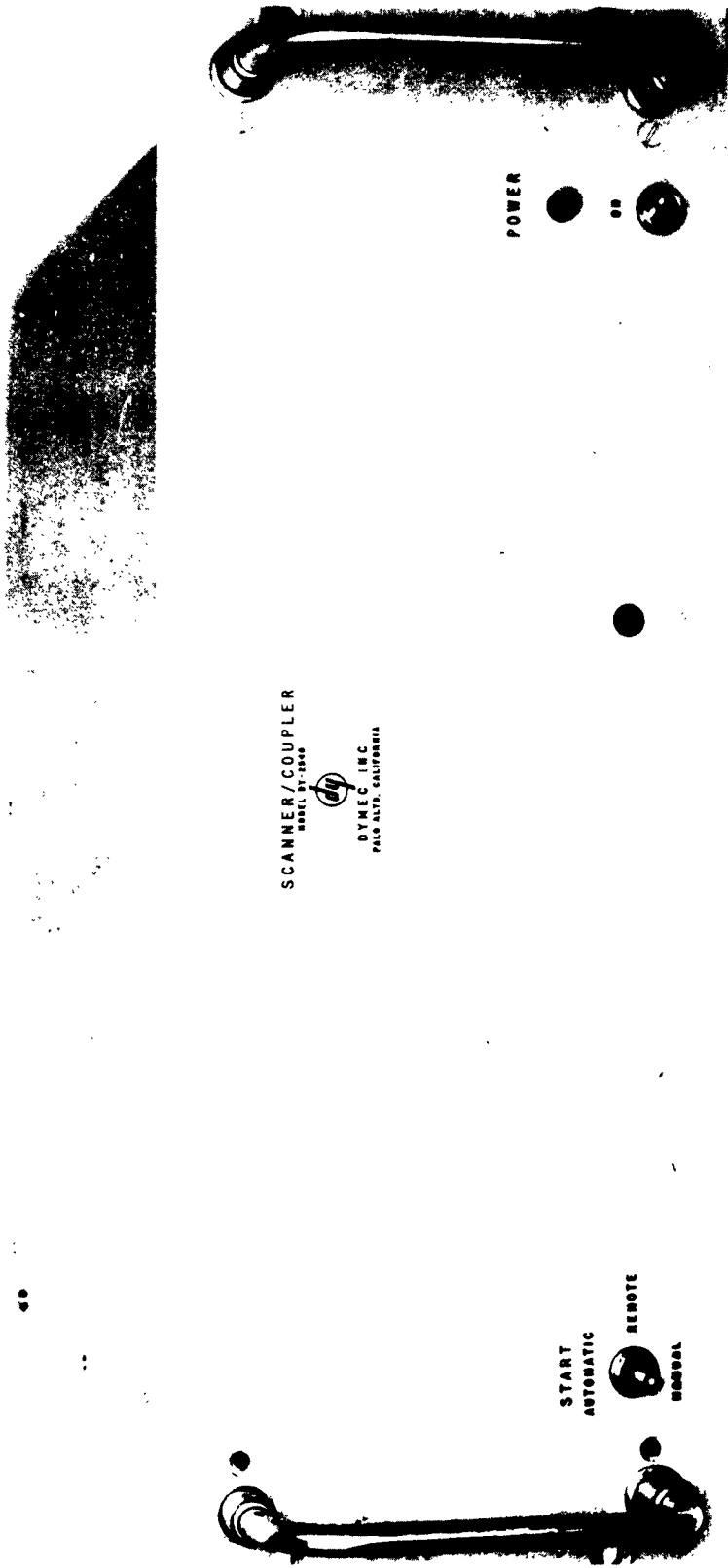

FIGURE 7
MODIFIED DY5304-4 SCANNER/COUPLER
FRONT

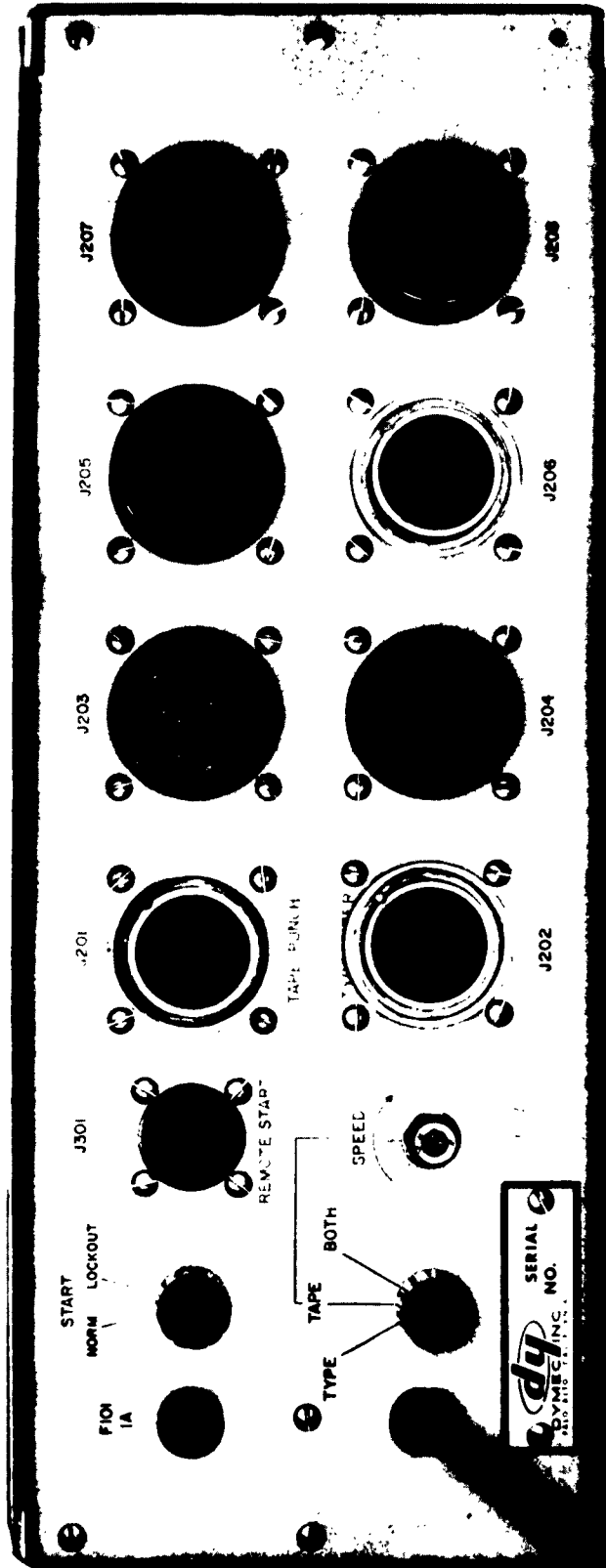

FIGURE 8
 MODIFIED DY 5304-4 SCANNER/COUPLER
 REAR

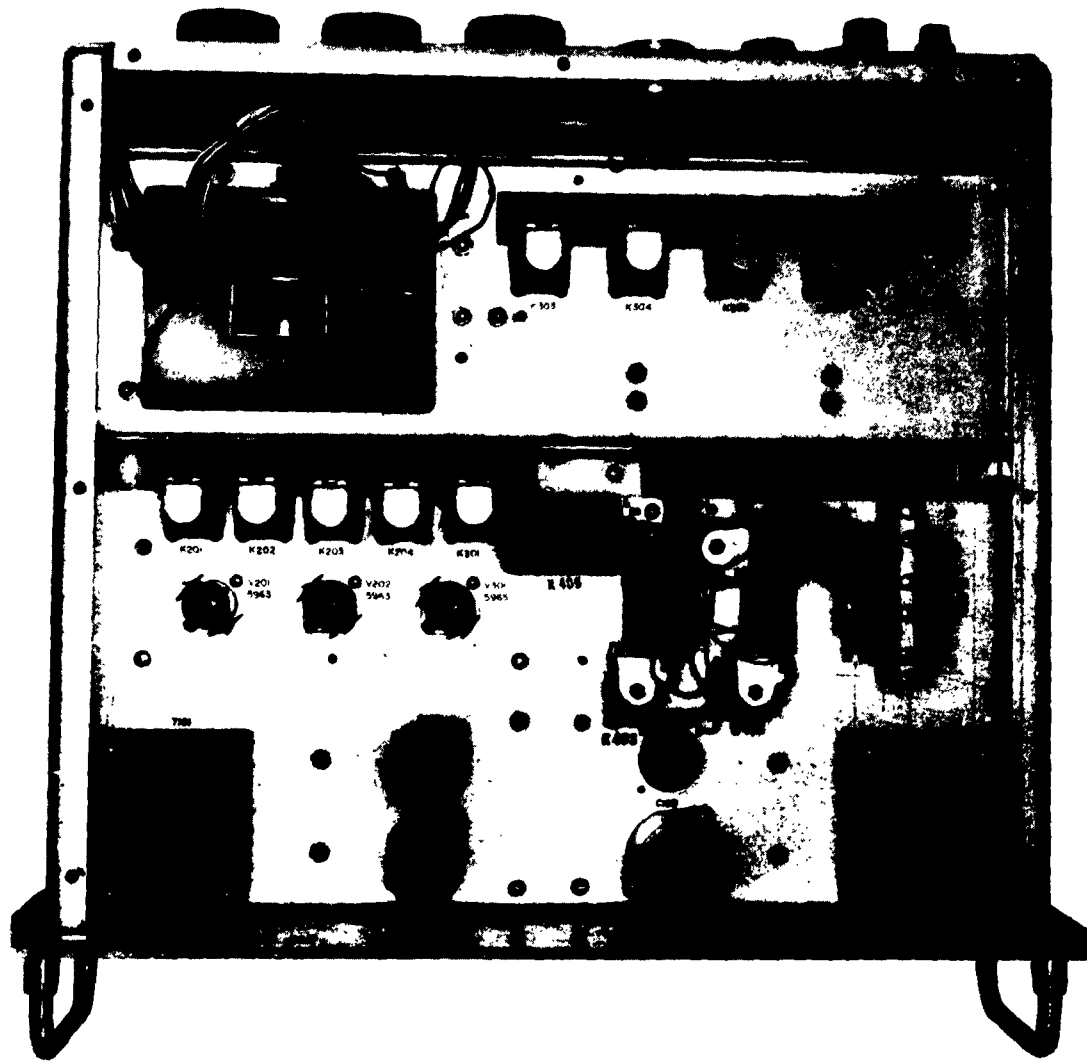

FIGURE 9
MODIFIED DY 5304-4 SCANNER/COUPLER
TOP

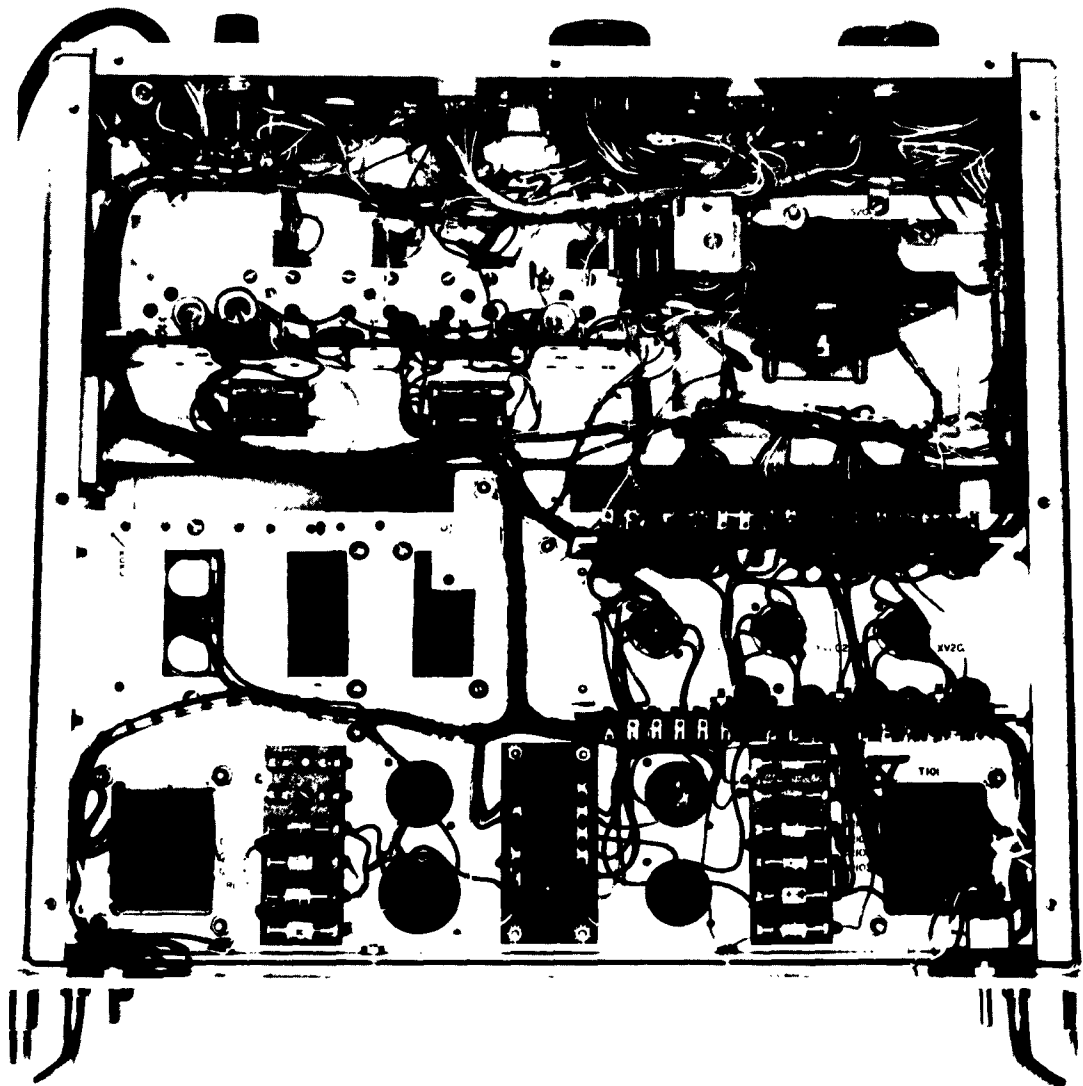

FIGURE 10
MODIFIED DY 5304-4 SCANNER/COUPLER
BOTTOM

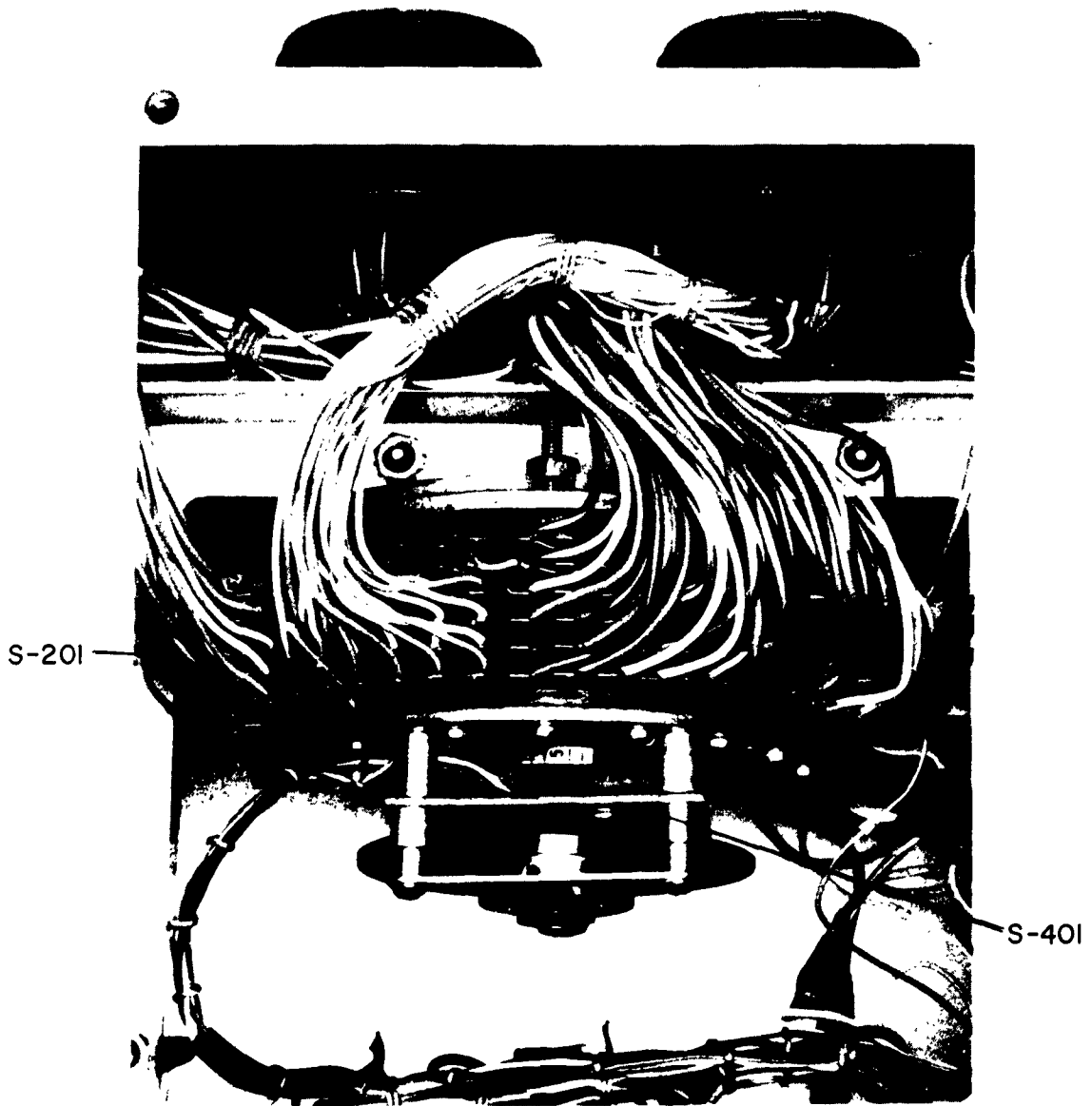

FIGURE II
MODIFIED DY 5304-4 SCANNER/COUPLER
PUNCH SELECTOR DETAIL

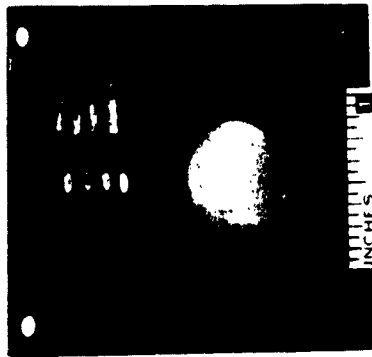
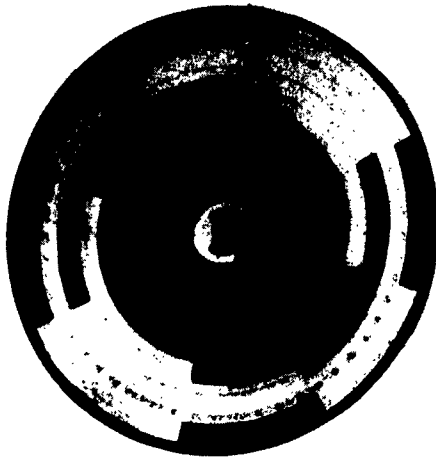

FIGURE 12
S-401 PUNCH SELECTOR SWITCH

Modifications were necessary to the DY-5304-1 clock and HP-560 A digital recorder #2 to enable time to be printed on the second HP-560 A digital recorder.

An additional input was added on the second HP-560 A digital recorder for receiving the clock #1 staircase voltages. Digital recorder #2 only prints time from clock #1 as presently wired.

Some modifications were also necessary to the Friden Model 2 motorized tape punches.

DY-5304-4 SCANNER/COUPLER MODIFICATIONS

Modifications were made to the scanner/coupler for two purposes: (1) to increase its data scanning capability, and (2) to make it operate with the Automatic Data Header Programmer. The modifications relating to the second purpose are described in "Automatic Data Header Programmer," DRL Report No. 488, CF-2988, by George G. Moore.

Most of the modifications to the DY-5304-2 scanner/coupler control circuits, as shown by Figure 5, were for adaptation to the Automatic Data Header Programmer.

Addition of isolating diodes CR 401, CR 402, and CR 403 was to prevent feed-through between separate punch clutch magnets. Clutch magnet and punch magnet ground return wires were rerouted through S-401 as described below.

No modifications were made to the power supply, shown in Figure 13.

The original DY-5304-4 scanner/coupler had unused scanning capability. S-201, operated by stepping relay K302, uses four of its six levels to scan the BCD outputs of decade counter units in the counters. There are 26 positions available and only 14 were used originally. The other 12 positions have been wired to receive the inputs from two additional DY-5304-2 time interval counters, even though only one additional counter is used presently. The data buss on S-201, Row E, was extended for positions 14 through 25 also. The counter disable, Row F, was not extended to include the two additional time interval counters, but could be if necessary.

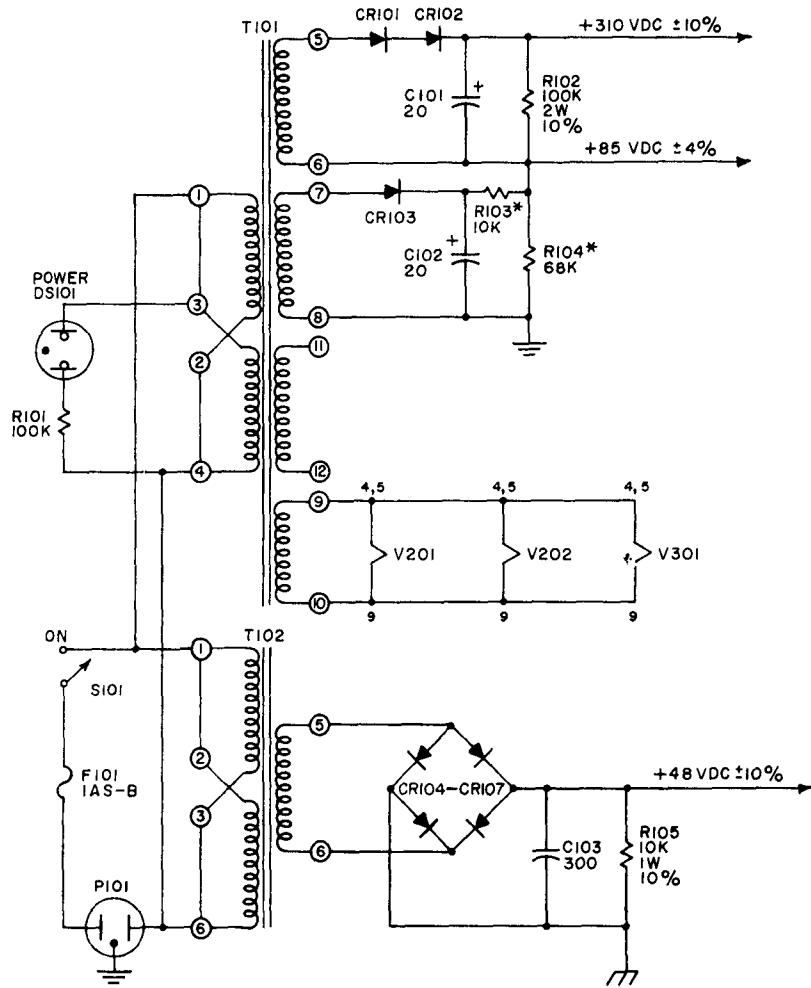

ALL CAPACITIES IN MICROFARADS; RESISTANCE IN OHMS $\pm 5\%$,
 1/2 W UNLESS OTHERWISE SPECIFIED.

CR101 THROUGH CR107 ARE TYPE IN1449/IN1084.

* SHUNT TO OBTAIN +85 VDC AT 115 VOLT LINE.

** VOLTAGES MEASURED WITH 115 VAC LINE.

COMMON POINT WHICH MAY OR MAY NOT BE GROUNDED.



FIGURE 13

DYMEC DY-5304-4 SCANNER/COUPLER POWER SUPPLY

Diodes were added at "n" on J-205 and J-207 to enable either time interval counter to delay the scan until its count was finished. All of the above circuit modifications are shown in Figure 6.

A major addition was S-401, a printed circuit rotary selector switch, Figures 11 and 12. S-401 selects which punch punches the information being scanned. It was necessary to have the time of day on each data tape so all three punches are selected for the first seven scan positions. This gives a "carriage return," "line feed," and 5 digits of time on each tape. Punch #1 is then selected to punch positions 8 through 13, giving the time interval for meter frequency counter 1 and completing the data point for punch #1. Then punch #2 is selected for positions 14 through 19, and punch #3 for positions 20 through 25. The punch selection is accomplished through S-401 by grounding the return for the punch and clutch magnets. If the return is not grounded through S-401, the punch will not activate for that scan position.

MODIFICATIONS TO OTHER EQUIPMENT

Digital recorder #2 printed the output of meter frequency counter #2 with no difficulty. But in order to print the 5 digits of time from DY-5304-1 time accumulator, clock #1, modifications of the digital recorder #2 input and clock #1 output were necessary. It is also necessary that the regulated supply voltages of the two HP-560 A recorders be the same. ± 2 volts.

In order to feed two digital recorders from the same decade, it is necessary to duplicate the staircase voltage network on each decade. The staircase output is fed out to pin #3 on the rear output plug at each decade.

An additional input plug was added to the HP-560 A digital recorder #2 in order to bring the 5 staircase voltages representing the digital readout of clock #1 to the appropriate comparator inputs.

Isolating diodes were added to the punch magnet input lines. This prevents feedthrough between punch magnets of separate punches when two or more punches are used with the modified system. The punch wiring is shown in Figure 14.

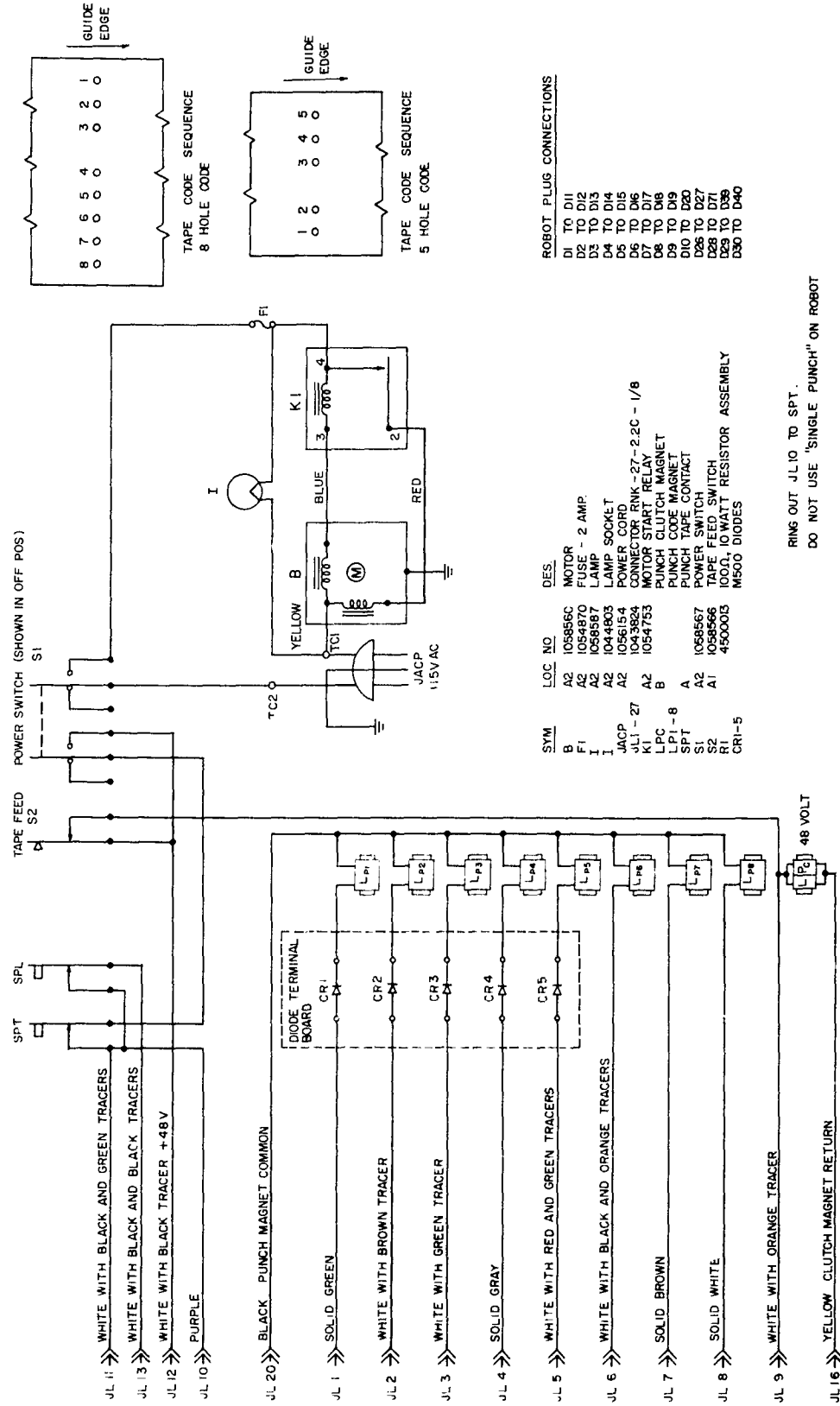

SYM	LOC NO	DES.
B	A2	105856C
F1	A2	1058470
I	A2	1058587
J	A2	1044903
J1	A2	1056154
K1	A2	1043824
LPC	A2	1054753
Lp1-8	B	
SPT	A	
S1	A2	1068567
S2	A1	1058566
R1	A1	4500013
CR1-5		M500 DIODES

MOTOR
 FUSE - 2 AMP.
 LAMP SOCKET
 POWER CORD
 CONNECTOR RNK-27-2.2C - 1/8
 MOTOR START RELAY
 PUNCH CLUTCH MAGNET
 PUNCH CODE MAGNET
 PUNCH TAPE CONTACT
 POWER SWITCH
 TAPE FEED SWITCH
 100Ω, 10 WATT RESISTOR ASSEMBLY
 M500 DIODES

ROBOT PLUG CONNECTIONS
 D1 TO D11
 D2 TO D12
 D3 TO D13
 D4 TO D14
 D5 TO D15
 D6 TO D16
 D7 TO D17
 D8 TO D18
 D9 TO D19
 D10 TO D20
 D26 TO D27
 D28 TO D71
 D29 TO D36
 D30 TO D40

RING OUT J.L10 TO SPT.
 DO NOT USE "SINGLE PUNCH" ON ROBOT

JL 13, 14, 15, 17, 18, 19, 21, 22, 23, 24, 25, 26, 27 - SPARES

FIGURE 14
 MODIFIED FRIDEN MODEL 2 MOTORIZED PAPER TAPE PUNCH

CONCLUSION:

Modification of the Dymec DY-5304 system for two channel data reduction enabled Station 002 to double its capability with a minimum of expense yet retain the demonstrated reliability of the previous system. Many hours of use have proven the reliability, with proper maintenance, of the modified system. It has made possible simultaneous reduction of two channels of doppler and refraction error data. Such simultaneous reduction is essential for accuracy and reliability of data, and full recovery of refraction information.

The initial distribution of this document has been made in accordance with a list on file in the APL/JHU Technical Reports Group. Requests for additional copies should be addressed to The Johns Hopkins University Applied Physics Laboratory, Silver Spring, Maryland, Attention: Supervisor, Technical Reports Group.