

UNCLASSIFIED

AD. 296 560

*Reproduced
by the*

**ARMED SERVICES TECHNICAL INFORMATION AGENCY
ARLINGTON HALL STATION
ARLINGTON 12, VIRGINIA**



UNCLASSIFIED

NOTICE: When government or other drawings, specifications or other data are used for any purpose other than in connection with a definitely related government procurement operation, the U. S. Government thereby incurs no responsibility, nor any obligation whatsoever; and the fact that the Government may have formulated, furnished, or in any way supplied the said drawings, specifications, or other data is not to be regarded by implication or otherwise as in any manner licensing the holder or any other person or corporation, or conveying any rights or permission to manufacture, use or sell any patented invention that may in any way be related thereto.

296 560

STZ/Rep 8640-6012 - CA 002

AD No. —

ASTIA FILE COPY 29 6560

e.1

Dun
①

8640-6012-CU000

MONTHLY PROGRESS REPORT NO. 3
SPECIFICATION DESIGN STUDY
FOR
FLIGHT TESTING INERTIAL GUIDANCE SYSTEMS
GEM
(GUIDANCE EVALUATION MISSILE)

1 March 1962

PROPERTY OF
SPACE TECHNOLOGY LABORATORIES

SPACE TECHNOLOGY LABORATORIES, INC.
No. 1 Space Park
Redondo Beach, California

MONTHLY PROGRESS REPORT NO. 3

SPECIFICATION DESIGN STUDY

FOR

FLIGHT TESTING INERTIAL GUIDANCE SYSTEMS

G E M

(GUIDANCE EVALUATION MISSILE)

1 MARCH 1962

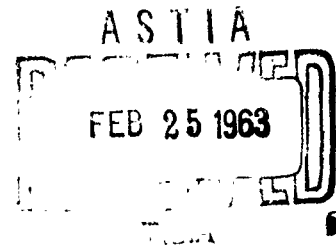

L. N. Jenks
L. N. Jenks

Approved: *A. N. Drucker*
A. N. Drucker

Approved: *T. W. Layton*
T. W. Layton

SPACE TECHNOLOGY LABORATORIES, INC.
No. 1 Space Park, Redondo Beach, California

IDENTIFICATION OF THIS PROGRESS REPORT IS AS FOLLOWS:

CONTRACT NUMBER: AF 29(600)-3300

AIR FORCE PROGRAM STRUCTURE NUMBER: 730D

ARDC PROJECT NUMBER: 5177

ARDC TASK NUMBER: 517703

C O N T E N T S

	PAGE
FOREWORD	1
ABSTRACT	1
CONTRIBUTING ORGANIZATIONS	2
I. INTRODUCTION	3
II. PROGRESS DURING REPORTING PERIOD	5
A. ESTABLISHMENT OF TEST PHILOSOPHY, TEST OBJECTIVES AND TEST CONDITIONS	5
B. TRAJECTORY REQUIREMENTS	5
C. ANALYSIS REQUIREMENTS EFFORT	20
D. TEST ITEM REQUIREMENTS	28
III. ACTUAL PROGRESS VERSUS PLANNED PROGRESS	31
IV. POSSIBLE SOURCES OF DELAY TO STUDY PROGRAM	32
<u>APPENDICES:</u>	
1. ENGINEERING TASK LAYOUT - PROJECT GEM	33
2. TRAJECTORY ANALYSIS	34
3. THERMODYNAMICS	70
4. AERODYNAMICS	103
5. AIRBORNE TRANSPONDERS AND BEACONS	123
6. ANTENNA SYSTEM PARAMETERS	129
7. PCM CRITERIA	133
8. FM/FM CRITERIA	144
9. TEST ITEM INTEGRATION	152
10. STELLAR/INERTIAL TEST FIXTURE DESIGN REQUIREMENT	159
11. REFERENCES	164

F O R E W O R D

The study progress described in this report was accomplished during the period 22 January 1962 through 28 February 1962 in partial fulfillment of the requirements of the Specification Design Study under Contract AF 29(600)-3300.

A B S T R A C T

~~This report describes the third month's progress of a Specification Design Study for flight testing inertial guidance systems.~~ ^{ON} ~~Areas of effort accomplished during the reporting period include continued development of the error simulation program, partial establishment of a recommended ground tracking system, and survey of existing data handling facilities. Further trajectory, thermodynamic and aerodynamic analysis, additional layout of the final stage vehicle, PCM and FM telemetry criteria development, initial design of the control autopilot system and partial test item integration were accomplished.~~ _{is reported,}

CONTRIBUTING ORGANIZATIONS

The GEM study program at the Space Technology Laboratories, Inc., is being accomplished by a task force organization, the members of which come from the several laboratories and departments. Listed below by name are those engineers who have contributed effort to the progress described in this report.

INERTIAL GUIDANCE AND CONTROL LABORATORY

Inertial Guidance Department

L. N. Jenks	-	GEM Task Force Director
B. R. Ackerson)	Test Item Integration
B. H. Evans		
R. A. Bain)	External Tracking System
K. H. Baird		
G. R. Shook		
J. P. Miller	-	Inertial Guidance Testing
M. F. Popelka	-	Survey and Optical Alignment
R. A. Moore)	Error Analysis and Simulation Program
J. R. Westlake		

Controls Department

E. P. Blackburn	-	Control System Analysis
R. J. Goad	-	Control System Analysis
H. Kaichi	-	Control System Analysis
R. B. Sherwood	-	Control System Analysis

GUIDANCE LABORATORY

Radio Guidance and Tracking Department

R. Anders	-	External Tracking and Command Guidance
W. R. Sorkin	-	External Tracking and Command Guidance

SYSTEMS RESEARCH LABORATORY

Systems Design Department

L. Becker	-	Booster Configuration - FSV Design
P. C. King	-	Booster Configuration - FSV Design
C. A. Knight	-	Booster Configuration - FSV Design
J. Orr	-	Antenna Design

Systems Analysis Department

B. A. Wine	-	Trajectory Analysis
------------	---	---------------------

AEROSCIENCES LABORATORY

Aerodynamics Department

G. Lippmann	-	Aerodynamics
H. R. Wilkinson	-	Thermodynamics

COMMUNICATIONS LABORATORY

Communications Equipment Department

G. S. Kasai	-	Antenna Design
J. A. Cone	-	Antenna Design

PROPULSION LABORATORY

Propulsion Development Department

B. Siegel	-	Attitude Control
-----------	---	------------------

I. INTRODUCTION

On 15 November 1962, Space Technology Laboratories, Inc. was placed on Contract AF 29(600)-3300 with AFMDC to accomplish a preliminary engineering design for the GEM (Guidance Evaluation Missile). This design effort is to be completed within four and a half months of the above date with the final report being submitted within six months.

The objective of this engineering effort is to provide the specification design and methodology to implement non-destructive testing of inertial guidance systems and components through use of a pre-programmed flight test vehicle. Included therein is the ancillary instrumentation to provide the precise meaningful data required to accomplish inertial system evaluation. The detailed objectives of this design effort are contained in the Statement of Work AF 29(600)-3300.

The STL design study effort is organized in three main task areas, these being further divided into sub tasks. Appendix 1 is a diagram of this task layout as proposed for accomplishment. Generally, once the GEM test philosophy, test objectives, and test conditions have been established, the study is divided into three areas; analysis requirements, trajectory requirements, and test item requirements. Inspection of Appendix 1 will indicate the further subdivisions and interface of the tasks. Each block of the task layout is the responsibility of some individual or organization within STL. Further, the GEM task layout is based on a rough four-month time scale, reading from top to bottom chronologically. It is to be noted that such a layout is essential for planning, guidance, control and coordination within the Task Force and should not be interpreted otherwise. Obviously, such a layout must be flexible so as to be subject to possible modification as problem areas are disclosed and design criteria becomes progressively defined.

Discussion of the study progress during the reporting period which follows may more easily be followed by occasional reference to the task layout (Appendix 1). By so doing, the reader will readily obtain a clear picture as to detailed task interface and study progress. Task accomplishment to date is shown on Appendix 1 as cross-hatched and shaded areas.

This report discusses the engineering effort that has occurred subsequent to that effort covered by the first and second months' report. References (1) and (2).

Paragraph II (Progress During Reporting Period) covers the conclusions and the significant study features. The various appendices provide the study detail, as known at this time, some of which may be a repeat of portions of Paragraph II. Further, some of the detail included may appear to be a repeat of previously reported data. However, it has been updated and is included to lend continuity to the reader. This is particularly true of the thermodynamics data.

II. PROGRESS DURING REPORTING PERIOD

A. Establishment of Test Philosophy, Test Objectives and Test Conditions

This subject was initially defined in Reference 1 early in the study program. However, further consideration has led to the conclusion that the subject of GEM guidance system testing should receive additional attention. It is particularly desired to establish a more definitive test objective for system testing, focused on guidance system accuracy determination for operational ranges and environment. Study of this subject is now underway and will be reported upon in the final report.

B. Trajectory Requirements

1. The two trajectory programs, as reported in Reference 2 at the end of the last reporting period remain the same as far as sequence and objectives are concerned. However, the recent receipt of data on the ALGOL II improved performance has necessitated the re-running of the trajectory programs which has resulted in some modification of the trajectory parameters. The improved ALGOL performance reflects increases in the thrust level and in propellant loading through the change in grain design; however, the overall burning time remains unchanged. Further, the new trajectory runs reflect the increase in payload weight of the final stage vehicle to 137⁴ pounds from the previously assumed weight of 1,000 pounds. Tentative event schedules are shown in Figure 1 and Figure 2. The resulting trajectories, pitch programs, and impact locations are described in Appendix 2. It is considered at this time that these trajectories for Programs A and B are now firm and will not be altered for the duration of this study.

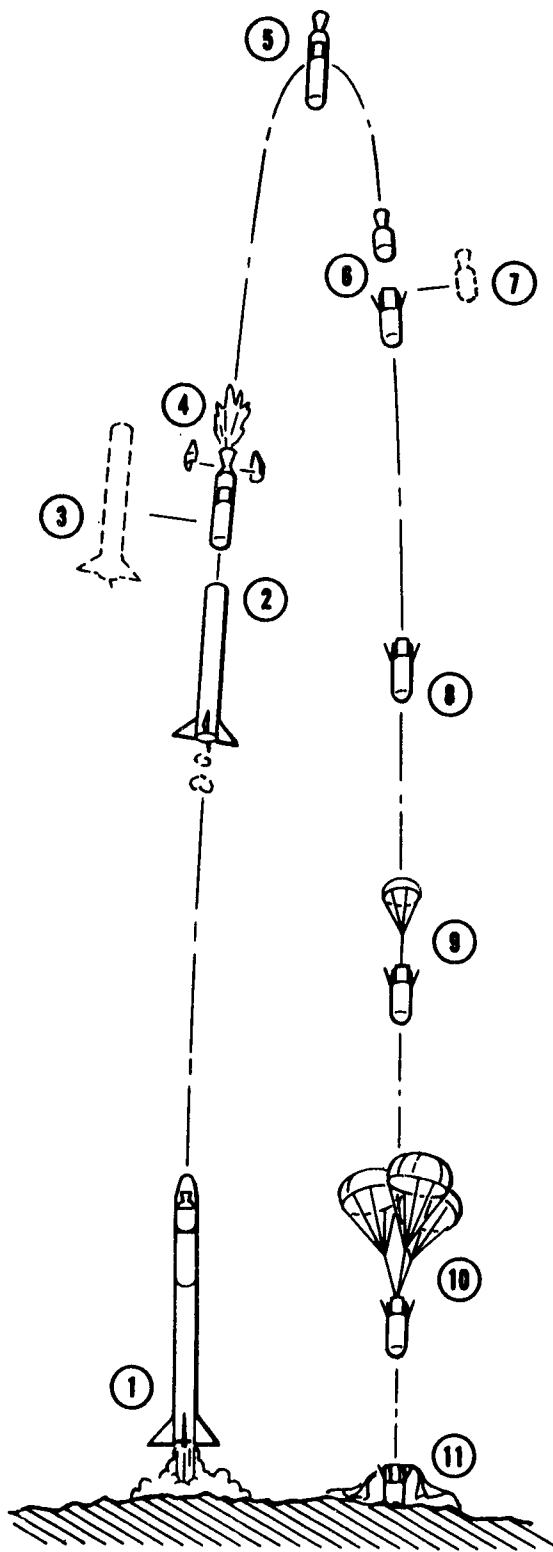

PROGRAM IA EVENT SCHEDULE

EVENT	TIME (sec)	ALTITUDE (ft)
1. Launch	0.0	4,000
2. First Stage Burnout, Separation, Jettison Fairing	60.0	250,900
3. First Stage Displacement	62.0	266,800
4. Ignite Second Stage	80.0	404,000
5. Apogee	116.0	543,300
6. Second Stage Burnout, Separation, (flaps extend)	128.0	532,700
7. Displace Second Stage	130.0	530,200
8. Re-entry	215.0	300,000
9. Deploy Drogue Chute	324.0	15,000
10. Deploy Main Chute Cluster	334.0	13,400
11. Impact and Recover	660.0	4,000

FIGURE 1

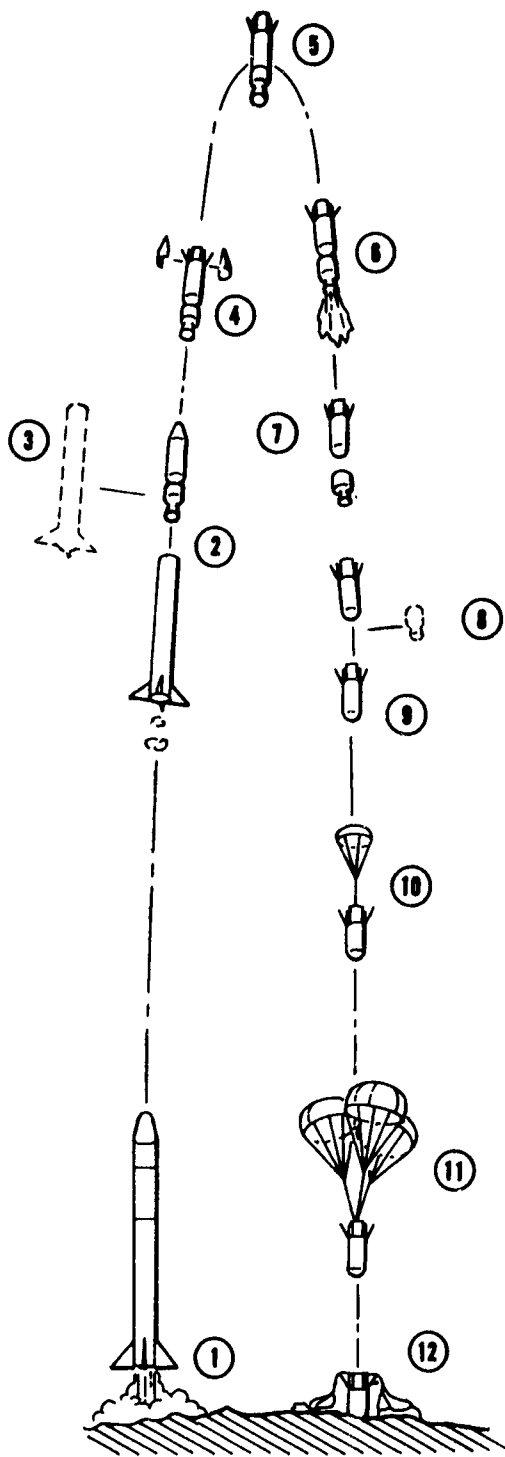

PROGRAM IB EVENT SCHEDULE

EVENT	TIME(sec)	ALTITUDE(ft)
1. Launch	0.0	4,000
2. First Stage Burnout, Separation Jettison Fairing	60.0	251,000
3. Displacement First Stage	62.0	266,800
4. Coast		
5. Apogee	331.0	1,314,100
6. Ignite Second Stage	538.0	700,000
7. Second Stage Burnout, Separation	586.0	565,500
8. Displace Second Stage	588.0	565,000
9. Re-entry	708.0	300,000
10. Deploy Drogue Chute	817.0	15,000
11. Deploy Main Chute Cluster	827.0	13,400
12. Impact and Recover	1147.0	4,000

FIGURE 2

B. Trajectory Requirements (Continued)

2. Trajectories are currently being run using a vehicle made up of Pershing A-1 as the first stage and Pershing B-2 as the second stage with the 1375 pound payload for the purpose of determining the resulting performance. The results of this trajectory program will be reported upon in the final report.
3. It was of interest to briefly evaluate the performance of the GEM configuration when used as a range calibration vehicle. This evaluation involved simulating a trajectory with a B-2 stage firing immediately subsequent to the ALGOL burnout to achieve a high velocity and altitude. The performance parameters of the combination are indicated in Figure 29 of Appendix 2.
4. Final Stage Vehicle Design
 - a. Thermodynamics - The completion of the thermal analyzer program has been accomplished for the various stations on the final stage vehicle and for the various combinations of structural material and AVCOAT under consideration. The conclusion reached from this thermodynamic analysis is that with a .1 inch coating of AVCOAT on the sensitive areas of the structure, the temperature rise within the structure members will remain below the maximum that can be tolerated for structural integrity. Complete details of the thermodynamic analysis is contained in Appendix 3. It should be noted that some of the data contained therein is similar to that which was contained in a previous monthly report; however, this data has been updated and is included for continuity.
 - b. Aerodynamics - The aerodynamics analysis has been principally completed, the results of which are included in Appendix 4. Computation of force coefficients and centers of pressure for ascent and descent vehicles and pressure distribution on these vehicles at various points along the respective trajectories has been achieved. Effort was also extended to obtain a flare configuration on the entry vehicle that would provide stabilized aerodynamic characteristics throughout the descending portion of

the trajectory. Study was also accomplished to determine the drag resulting from the protrusions of the lateral displacement rockets mounted on both the ALGOL and B-2 engines. It is considered that the aerodynamic effort for the GEM study has been concluded at this time.

- c. Bending Mode Calculations have been recomputed three times due to the variance in requirements. Initially, the run was based upon standard ALGOL data and 1000 pound payload. The second run was based on improved ALGOL data and 1000 pound payload. The computations now under way reflect the 1375 pound payload, it being anticipated that such is the final data.
- d. Structure Design - Drawing number PD28-012 shows the configuration of the complete GEM vehicle for both Program A and B missions. Analysis has disclosed that the Pershing B-2 stage is structurally adequate for the Program B arrangement flight loads and overstrength for the A arrangement loads. The FSV, conversely, is designed to sustain the flight loads imposed by the Program A arrangement and is overstrength for the Program B arrangement. The differential strength factor is not too extreme and the weight penalty for standardization of major components is small. It will be noted that the final total vehicle length is approximately 55 feet 9 inches for either mission.

Detail design of the Final Stage Vehicle (Program A and B) are shown on Drawings PD28-013 and PD28-014. It may be noted that the test item (Inertial Guidance Unit) has been placed forward. (Forward is considered to be in the direction of the Re-entry Shield). It has been found that the higher density equipment located in this region will not require the volume depth considered earlier.

The higher density equipment consists of the dual Strobe beacon system, and the power supply. All other equipment will mount between the parachute compartment and the test item(s).

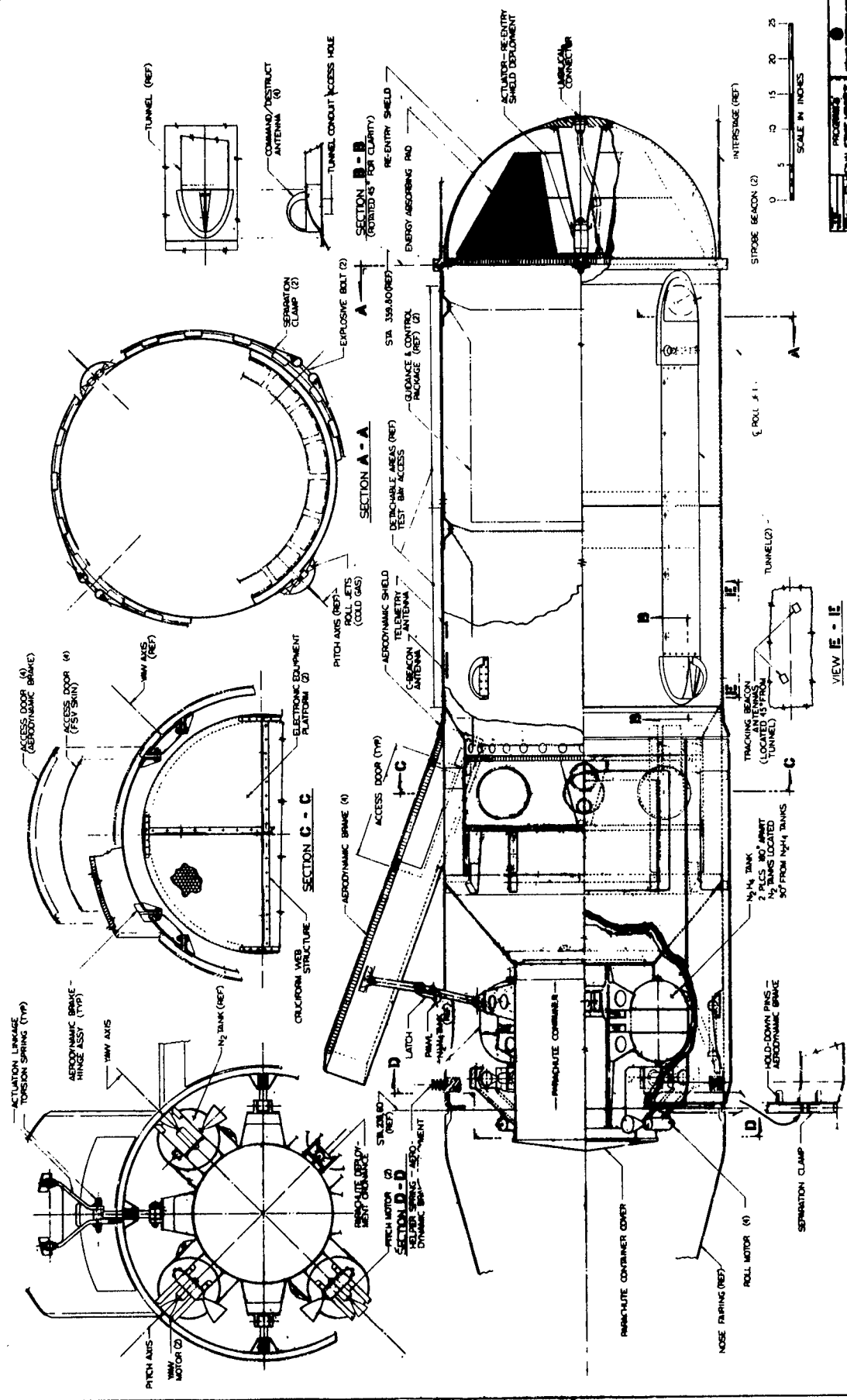

d. Structure Design (Continued)

Another factor contributing to the forward placement of the test items was the requirement for guidance windows. The former position would have located such a window in the flap region. The present arrangement allows the window to be installed in the constant-section monocoque skin.

Design of the aerodynamic flap has progressed and each flap now has a large removable center section. Beneath this removable section on the FSV exterior is a structural door, allowing access to electronic equipment. Aerodynamic tunnels are now located on the FSV exterior. These tunnels mount the cold gas nozzles, valves and pneumatic lines, leaving the FSV interior unobstructed for the test item installation. The strobe lights are placed behind a high temperature shield at the forward end of the tunnels.

The re-entry shield releases from the FSV at the instant of parachute deployment which fully exposes the Trussgrid honeycomb energy absorber so as to best meet design conditions. An explosive thrust actuator has been provided to augment this release. A reliable series of such thrust actuators commonly used for the separation of nose fairings have been developed. These units are capable of withstanding high tensile loads at all times prior to detonation providing an ideal method for retaining the re-entry shield.

e. Weight and Balance Effort

Work has been completed on the complete weight data study for Program A. This consists of a weight history, supporting stage weight breakdowns, detailed weight breakdown of the FSV, weight, longitudinal center of gravity, pitch and roll moments of inertia vs. time curve and a GEM FSV equipment list. As some of the data is classified, this will be published separately. Similar data for Program B is forthcoming, it being essentially the same as Program A, except for center of gravity and moment computations.

f. Control Systems

Reaction Jet Control System

Design of the reaction jet attitude control system is being refined. This control system provides pitch, yaw, and roll stabilization during vehicle coast periods - between ALGOL separation and Pershing ignition, and from Pershing separation to re-entry of the Final Stage Vehicle. Also, the reaction jet system will control the FSV in roll on re-entry prior to parachute deployment.

The reaction jet control systems designed for each GEM mission A and B are quite similar although the requirements of each mission differ. For mission A it is necessary to locate pitch and yaw coast control jets (four in all) below the test item at the periphery of the FSV. The four roll jets are placed there also, and as the impulse required during coast on this mission is low, the coast control system utilizes cold gas for simplicity and reliability with little weight penalty. The reaction jet propellant supply, contained in two cold gas tanks and two hot gas tanks, and four jets used for re-entry roll control are positioned above the test item about the parachute canister. These jets employ hot gas since the impulse required to overcome the expected torques on re-entry is high. (See Figure 7, Appendix 4).

For mission B coast roll control is effected as in mission A, cold gas jets below the test item, since the impulse required is low. However, pitch and yaw jets for coast must be situated above the test item and will operate on hot gas because of large impulse requirements. The re-entry scheme is unchanged from mission A.

The attitude reference for this reaction jet system is a MIG gyro package located in the FSV. Rate information is added to the attitude error signals through lead-lag networks. The output of these networks is utilized to trigger the gas jet valves "on" and "off". The thrust required for the gas jets is: 14 lbs, pitch and yaw; 2.2 lbs., coast roll; 100 lbs., re-entry roll.

f. Control Systems (Continued)

Powered Flight Control System

The MIG gyros of the final stage vehicle serve as the attitude reference for the powered flight control systems of the Pershing and ALGOL stages. Commanded attitude rates are issued from the timer-programmer and the gyro attitude error outputs are sent to filters in each stage. This compensation consists of an integration to remove thrust misalignments, lead for rate information, and lags to attenuate high frequencies. The output of the filters drives the hydraulic servos. In both stages these actuate jet vanes located in the rocket exhaust. The ALGOL servos also rotate the fin tips.

The parameters of these autopilots are being selected to provide adequate rigid body and flexible body stability as well as to minimize drifts due to winds.

Dispersions

Although autopilot gains may be determined as a function of time to negate vehicle drift due to winds, these gains will not be realized in the control system. The required gain is often so large that limiting of the servos occurs and mechanizing the varying gain can be selected to give a reasonable approximation to the optimum. It is the intent of the dispersion studies to determine gains which will minimize drifts due to winds.

g. Airborne Transponders, Beacons and Receivers

A survey was performed of range safety and radio guidance and tracking airborne transponder and beacon requirements for GEM. FPS-16 radar (or radars) will track GEM for the purpose of supplying trajectory information to a computer. From the computer will come range safety and radio guidance command information which, when coded, will be sent to the missile by way of a 400 mc transmitter. When received at the missile by a 400 mc receiver the signals will be decoded (or demodulated) by range safety demodulators or radio guidance demodulators and appropriate control or destruct relays will be energized. In

order to accomplish this function three airborne units are required; a C band beacon; a 400 mc receiver; and demodulators. All three units are "off the shelf" items and are described in Appendix 5.

Transponder requirements for the precise radio tracking of GEM depend upon the selection of White Sands of a tracking system which will meet GEM requirements. For planning and final stage vehicle (FSV) design purposes a MISTRAM transponder was chosen. The characteristics of this unit are shown in the reference.

Two airborne strobe beacons will be required on GEM for ballistic camera tracking. There are surplus beacons available which were built and have been used on the Atlas. These beacons will be satisfactory if certain modifications are made. For example, it will be highly desirable to have as many as 400 or more flashes per flight as opposed to the present capability of the units to produce about 60. In conversations with the manufacturers, it is understood that a trade-off can be realized between light intensity and number of flashes. The maximum range requirements envisioned for GEM are about a factor of 3 less than the capability of the present Atlas strobe beacon. Therefore, the beacon intensity requirements could be reduced by about a factor of 9. This would allow for an increase in the number of flashes per flight and result in a significant weight reduction because a smaller charging capacitor would be adequate. There are no major problems anticipated in obtaining the larger number of flashes desired or in the integration of the units on GEM.

h. A/B Antenna Design

The final study of the GEM antenna system is underway, computer runs for each ground station having been completed. Tentative antenna locations are shown on Drawing PD28-013 and PD28-014. Details of the antenna effort to date are contained in Appendix 6.

i. System Operations

The tentative event schedule has been revised to reflect the latest trajectories:

EVENT SCHEDULE

<u>EVENT</u>	<u>EVENT INITIATED BY</u>	<u>A CONFIGURATION</u>		<u>B CONFIGURATION</u>	
		Time (Sec)	Altitude (Ft.)	Time (Sec)	Altitude (Ft.)
Launch	Ground Signal	0	4000 GL	0	4000 GL
Start Programmer	Ground Signal	0	4000 GL	0	4000 GL
Control w/ALGOL System	Ground Signal	0	4000 GL	0	4000 GL
S & A Armed	1st motion via lanyard	0+	4000 GL+	0	4000 GL+
Program Pitch Rate @ +0.18°/sec	Programmer	2	-	2	-
Program Pitch Rate @ +0.075°/sec	Programmer	10	-	10	-
Program Pitch Rate @ 0°/sec	Programmer	50	-	50	-
Arm ALGOL Separation Switch	Programmer	50	-	50	-
ALGOL Separation	Axial Accelerometer @ near zero reading	60	250,900	60	250,900
Nose Fairing	Same signal as Separation	60	250,900	60	250,900
Assume Attitude Control w/FSV System	Same signal as Separation	60	250,900	60	250,900
Activate Timer 1st Stage Displacement Rockets	Separation	60	250,900	60	250,900
Displace ALGOL	Timer	62	266,800	62	266,800
Pershing Ignition	Programmer	80	404,000	538	700,000
Assume Cont. w/Pershing Sys.	Programmer	80	404,000	538	700,000
Prog. Pitch Rate @ -0.11°/Sec (A) @ -0.40°/sec (B)	Programmer	80	404,000	538	700,000
Program Yaw Rate .06°/sec (B)	Programmer	-	-	538	700,000
Program Pitch Rate @ 0°/sec	Programmer	123	-	581	-
Pershing Separation Open FSV Flaps - Assume Control w/FSV System	Axial Accelerometer	128	532,700	586	565,500
Activate Timer 2nd Stage Displacement Rockets Arm 2nd Stage Dest. System	Separation	128+	532,700	586+	565,500
Displace Pershing	Timer	130	530,200	588	565,500
Turn off pitch & yaw Control on FSV Arm Baro Switch	Accelerometer (at = 5) "				
Deploy Drogue Chute & Drop heat cap	Baro Switch	324.0	15,000	817	15,000
Activate Reefing Line Cutters and Deploy Main Chute	Timer set by Baro Switch above	334.0	13,400	827	13,400

j. Command Destruct Requirement

Discussion with WSMR Range Safety reveals that range safety requires the ability to command thrust cut off at any time during flight. As far as GEM is concerned, this specifically requires the ability via the command link to accomplish the following:

- (1) Command 1st stage thrust termination and deny ignition of the Pershing B-2, at any time during 1st stage powered flight.
- (2) Command 2nd stage thrust termination at any time during 2nd stage powered flight.

It will not be possible to use the B-2 termination ports to accomplish (2) as these ports do not become effective until 14 seconds after normal engine ignition.

An operational schematic of a command destruct scheme suggested by WSMR for GEM use is shown in Figure 3.

k. GEM Model

The model of the complete GEM vehicle has been assembled and is ready for transmittal. It is anticipated that the model will be delivered to AFMDC at time of technical presentation.

Termination System Power
(Prefer Separate
Source)

Lanyard

Safety & arming device;
armed on first motion,
preferably lanyard operated.

Lockout tail switch
between 1st & 2nd stages

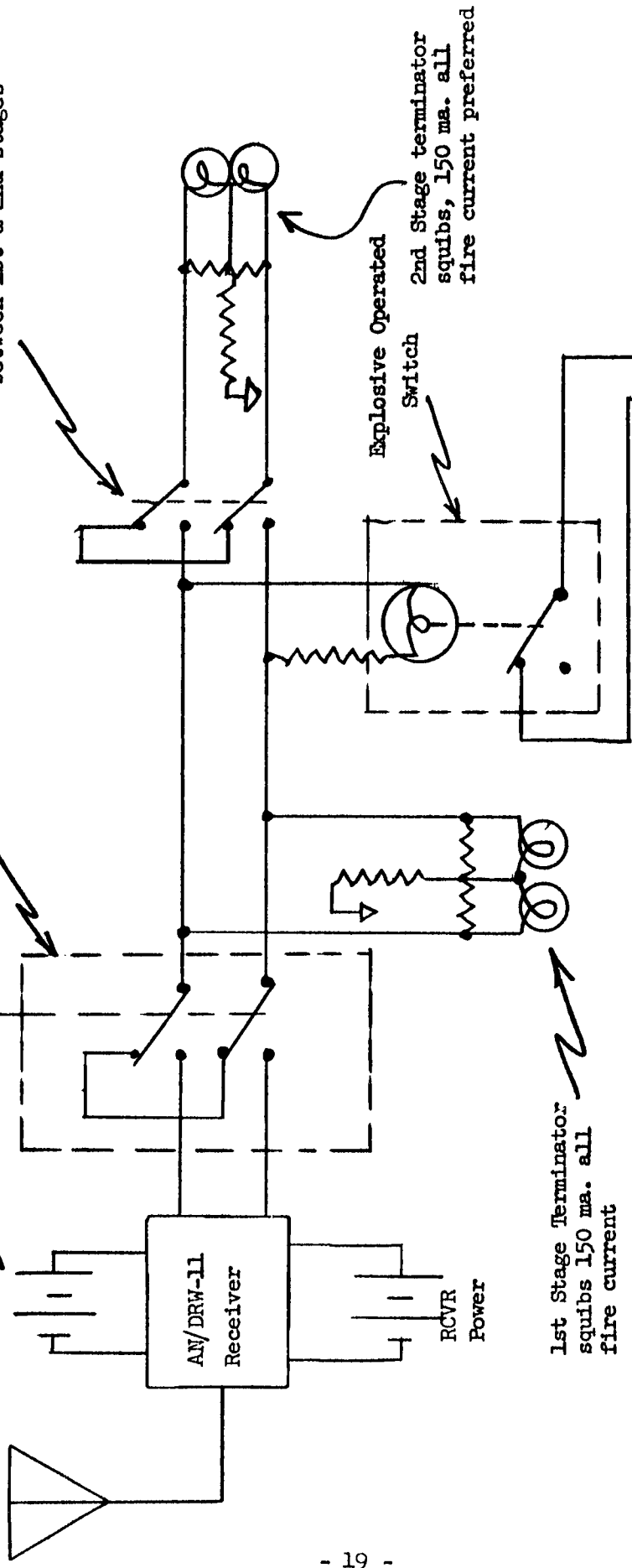

1st Stage Terminator.
squibs 150 ma. all
fire current

Explosive Operated
Switch
2nd Stage terminator
squibs, 150 ma. all
fire current preferred

Normally closed circuit to 2nd stage ignition circuit.
This circuit will open simultaneously with termination
command in order to prevent ignition of second stage.

PREFERRED THRUST TERMINATION CIRCUIT - NOTHING ELSE WILL
BE CONNECTED TO THIS CIRCUIT.

FIGURE 3

COMMAND DESTRUCT SCHEME

20

II. PROGRESS DURING REPORTING PERIOD (Continued)

C. Analysis Requirements Effort

1. Establishment of error coefficient recovery requirement was accomplished in Appendix 3, Reference 1. Further, the Ground System Criteria was established in Reference 2. Based on this, study of a recommended tracking system, a telemetry design criteria, and continued error analysis effort was accomplished, the results of which are discussed below.

2. Ground Tracking System

The tracking system configuration that has been used as an example in the preceding progress reports is one in which the basic measurements are range, range rate, the difference between two ranges and the differences between two range rates. This mechanization is arbitrary, of course, and an equivalent system could be implemented in many other ways. For example, the system could measure angular cosines and cosine rates or range sums and range sum rates. The important characteristic of the necessary system regardless of how it is implemented are:

- a. Range measurement by modulation of the courier using phase measurements on the modulated signal. A sufficiently high modulation frequency will have to be used to insure adequate precision. Lower frequency signals will have to be used to resolve ambiguities.
- b. Range rate measurements on the carrier frequency - a carrier frequency in X-band appears to offer the greatest potential accuracy.
- c. An interferometric system of measuring angles. This entails widely separated stations with coherent phase measurements of the differences between the signals received at these sites. A technique for stabilization of the electrical baseline length between these stations will be necessary.

- d. Using the above stations, the frequency difference between the received signals will have to be coherently measured either directly or by differentiation of the phase measurements.

This type of system with state-of-the-art components and with thorough engineering and calibration procedure and detailed data correction routines can provide the type of accuracy necessary for GEM.

The airborne antenna, as a part of the tracking system, should not be a major source of error. The tracking system will be phase coherent and the most important antenna characteristic needed is phase stability. Different requirements are needed to accurately measure range, range rate, two range differences and two range difference rates.

(A) Range Measurement

Range measurements will be made by a phase measurement of a ranging signal which will be modulated onto the carrier. The antenna characteristic needed to accurately measure range is a stable phase difference between a signal at the carrier frequency and a signal at the carrier, plus or minus the modulation frequency. After calibration, a change in this phase difference, $\Delta\Psi$, in electrical degrees, will cause an error in range, ΔR , in feet, given by

$$\Delta R = \frac{10^9}{f_m} \frac{\Delta\Psi}{360}$$

To keep the error under .5 feet, then the antenna must have a stable phase characteristic with frequency given by

$$\Delta\Psi \leq .18 \times 10^{-6} \text{ deg/cps}$$

This linear relationship should hold over several megacycles. For an example, with a modulation frequency of 5 mc and a carrier frequency of 8 kmc, the phase shift at 8 kmc and

that at 8.005 kmc should be stable relative to each other to within .9 electrical degrees.

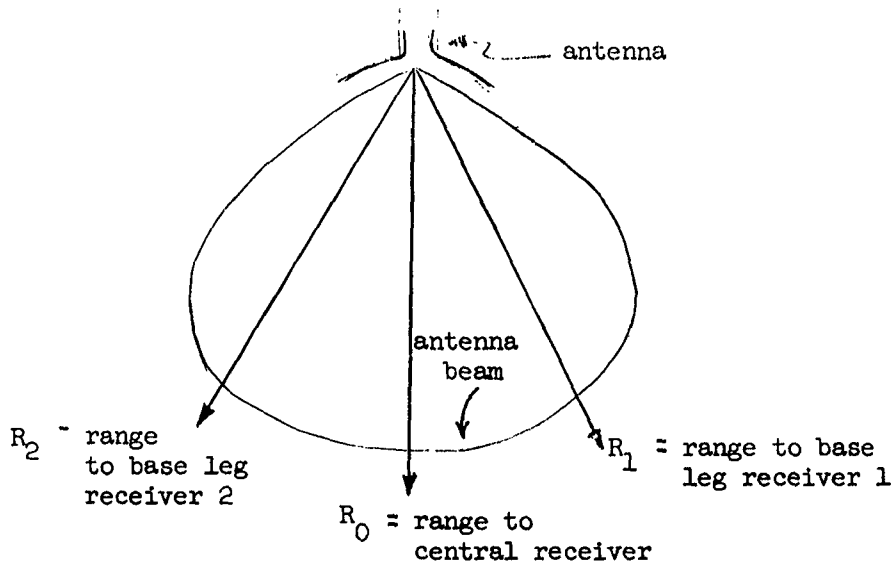

(B) Range Difference Measurements

The tracking system will measure the differences $R_0 - R_1$ and $R_0 - R_2$ on the x-band carrier. This measurement should be made to an accuracy of .01 foot. The antenna should not contribute more than .005 foot to the over-all inaccuracy. At 8 kmc, 1 wavelength is approximately 1/8 of a foot. Four-hundredths of a wavelength or about 15 electrical degrees would then represent .005 foot. This implies that the phase shift across the entire beam through which a line of sight passes should not change by more than 15 degrees relative to another line of sight. Therefore, in general, the relative phase shift across any two rays through the beam should be within 15 degrees. (See above sketch).

(C) Range Rate Measurements

Range rate is measured from the doppler signal which will have an approximate value of $(2\dot{R}_0/C)f_0$. Antenna phase shift changes should not cause an error of more than .08 cycles per second which is about 30 degrees per second.

This states that the change of phase shift should not exceed 30 degrees per second over the time of flight of the missile. This may be violated at staging but should hold over eventless portions of the trajectory.

(D) Range Difference Rate Measurements

Range difference rates ($\dot{R} - \dot{R}_{1,2}$) are determined from the doppler difference frequency which is about $(f_0/C) (\dot{R}_0 - \dot{R}_{1,2})$. The antenna should cause no error in these rates greater than .0005 ft/sec. The difference in rate of change phase shift over two paths through the beam should not exceed 1.5 deg/sec.

(E) Summary

For a carrier frequency of 8 kmc the following antenna phase stability characteristic should be attained if the antenna is not to be a significant source of error:

- a. With respect to frequency $.18 \times 10^{-6}$ deg/cps
- b. With respect to time over the trajectory 30 deg/sec
- c. With respect to different paths through the beam 15 deg
- d. With respect to time for different paths through the beam 1.5 deg/sec

3. Location of Tracking System Sites

Two sets of preliminary tracking system site locations have been selected. This selection was made from a map study in accordance with the criteria outlined in the second progress report. (Ref.(2). These site locations have not been discussed with White Sands; they do represent, however, what appears to be the best general area for location of a tracking system to cover the GEM trajectory. The latitude and longitude of the three stations are:

<u>Set 1</u>	<u>Latitude</u>	<u>Longitude</u>
Central Station	32° 11.75'	106° 13.6'
North Station	32° 23.2'	106° 10.6'
West Station	32° 14.2'	106° 26.3'

The base lines are about 70,000 feet in length. This configuration would require a minimum usable antenna beam width of about 115 degrees.

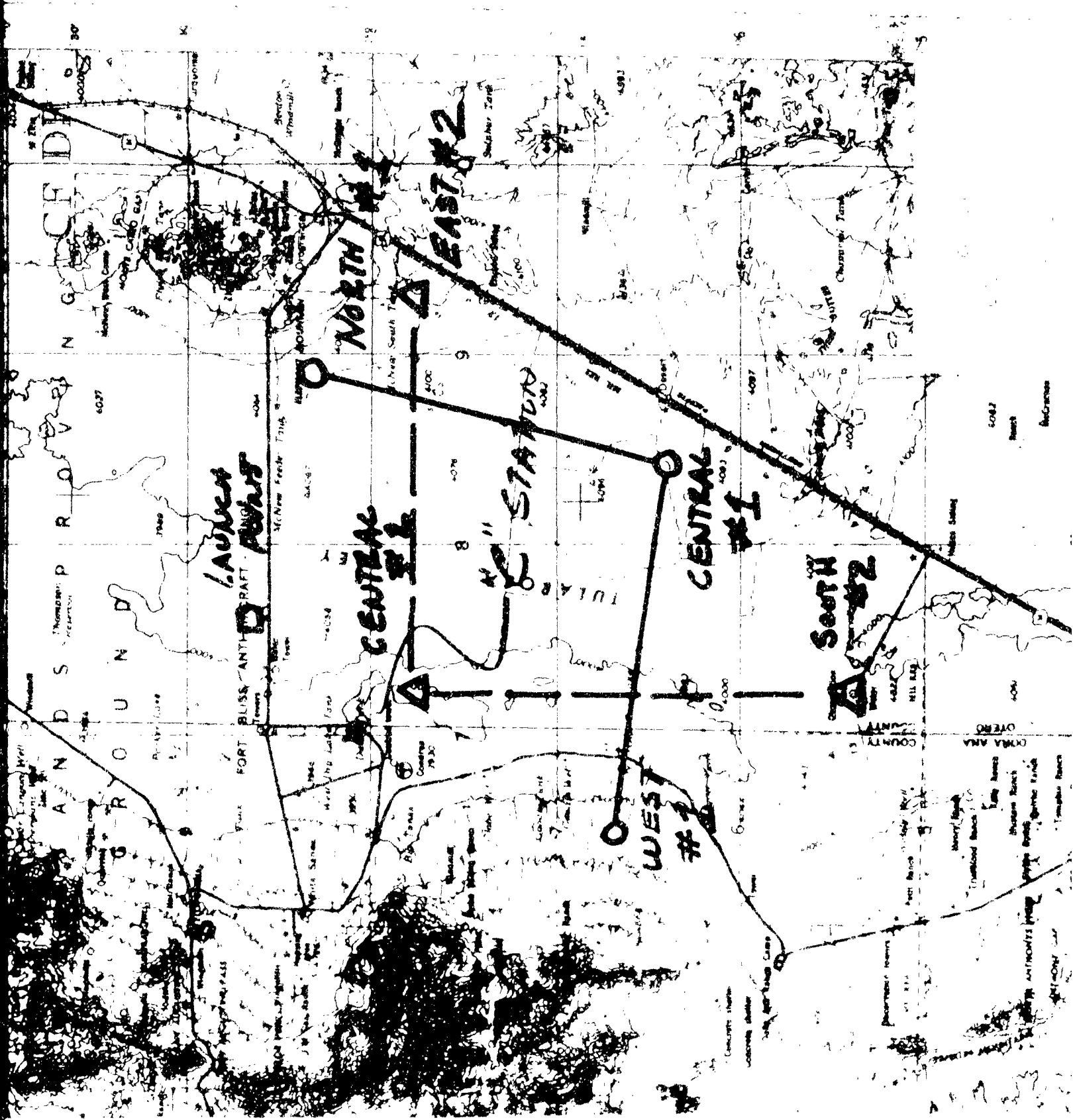

4. Telemetry Effort

a. PCM/FM System (Continued)

The PCM telemeter system is free running and is independent of the airborne digital computer. Such is required because of the impracticability of designing one system to operate with a large variety of computer bit rates. It is anticipated that on any GEM test requiring the evaluation of the digital computer, that either the PCM system peculiar to that test system can be utilized, or that buffers can be incorporated between the computer and the PCM to permit extracting a limited number of computer words.

Although the signal conditioning equipment specified for GEM would most easily be obtained by modifying the existing Minuteman (Autonetics) signal conditioner, the signal conditioning equipment envisaged is not complex and could easily be built from a new design.

The PCM telemeter system per se, can be obtained by modifying a Titan PCM system to fit the GEM requirements. This equipment is available in several modified forms and with the exception of the accumulator requirement would present no problem in design or modification. The only major modification proposed is the addition of six (6) accumulators to the system. However, with the spare room already available in the unit, and with the elimination of some Titan equipment not required for GEM, it is possible that the accumulation can be added within the existing unit with only a small increase in weight.

b. FM/FM System

Appendix 8 contains details of the FM/FM system design criteria.

5. Analysis, Simulation and Data Handling

The simulation effort is continuing but, due to unforeseen program limitations, the results are by no means complete. The pertinent facts that have come to light at this point are as follows:

- A. The correlation between the bias and quadratic together with a linear and cubic correlation will dictate an accurate pre-launch calibration for the constant and linear terms.
- B. The coefficients in the drift expansion for both the SDF and TDF gyros will probably require at least two flights for complete determination.
- C. The addition of radar noise did not materially affect the coefficient recovery. The noise had the following high and low frequency RMS values:

(1) High: $\sigma_R = .02$, $\sigma_P = \sigma_Q = .002$, $\sigma_R = .5$, $\sigma_P = \sigma_Q = .02$

(2) Low: $\sigma_R = .01$, $\sigma_P = \sigma_Q = .003$, $\sigma_R = .3$, $\sigma_P = \sigma_Q = .04$

The results are far from complete as previously mentioned; consequently, rather than quote out of context, the conclusions will be delayed until they are more securely based.

The analysis covering geophysical data inputs with reference to survey accuracy requirements has been completed. The component calibration accuracy requirements formed the basis for this analysis. The free flight bias determination has been analyzed with regards to telemetry requirements that are imposed.

The required transformations have been formulated but are not included in this report since their inclusion in the final report appears to be more appropriate. The flow diagrams outlining the data flow and data handling have been completed and were discussed with the personnel of the AFMDC/HAFB computation center. In addition, a recommended "quick look" analysis program is being formulated.

II. PROGRESS DURING REPORTING PERIOD (Continued)

D. Test Item Requirements

1. Study of the integration of various guidance systems into GEM has been partially completed. The systems given consideration to date are the Minuteman N10 and the MIT 2-16. Effort is being initiated to examine the Sting systems (both Kearfott and ASCP, although they are similar).. The purpose of such investigations is to determine if indeed specific systems can be integrated into the GEM system as currently being designed. The results of these investigations documented in Appendix 9.
2. Design of the final stage vehicle test item compartment has incorporated easy access to both test items. Such access will facilitate test item maintenance and adjustment in the missile assembly area and while on the launch pad. Drawing PD 28-015 illustrates test item access.
3. The general approach and techniques to be employed as well as the equipments to be used have been specified for the GEM missile and platform alignment, control and monitoring. It is currently envisioned that commercially available photoelectric autocollimators, Bilby towers and theodolites will be employed. Specific recommendations as to the associated facilities requirements so as to insure maximum stability are currently being prepared.
4. Establishment of a design criteria for an inertial test fixture (GEM/USITF) to test inertial components has progressed, the criteria being modified by some fundamental changes in philosophy over the draft published in the January report. (Reference (2)). The revised criteria is contained in Appendix 10.
 - a. It is assumed reasonable to test gyros by caging with their own output current. This current will measure both platform drift and test specimen drift so it will be essential to minimize platform drift.

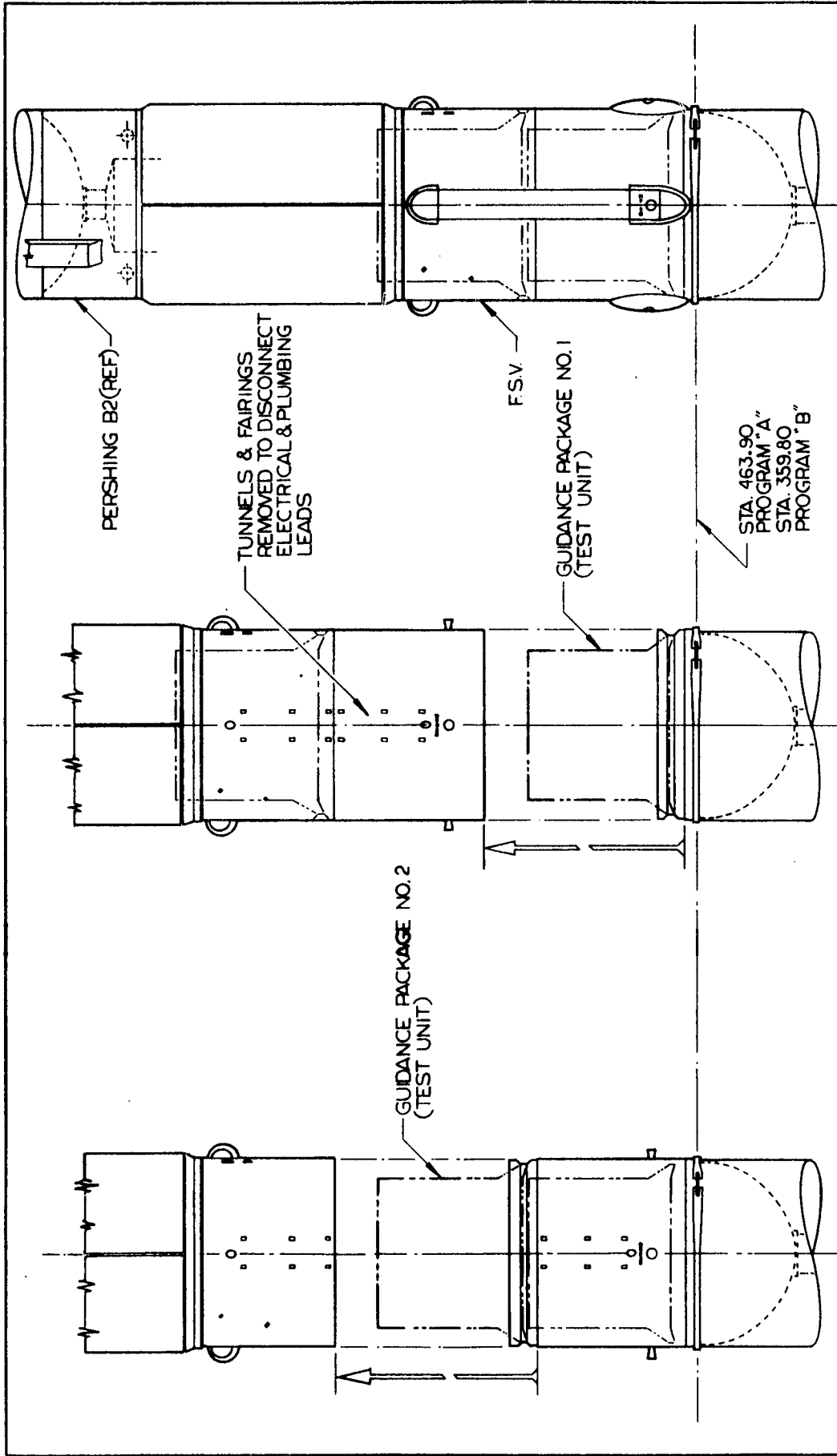

PD 28-015
SPACE TECHNOLOGY
LABORATORIES, INC.
LOS ANGELES 44, CALIFORNIA

TEST UNIT INSTALLATION & ACCESS ARRANGEMENT

1/20 SIZE

(2) Instrumentation Sensors

(a) Two accelerometers normal to thrust, that is in x, y plane capable of measuring a maximum of 500 ft/sec to within 1 part in 20,000.

(b) One accelerometer parallel to thrust capable of measuring a maximum of 8,000 ft/sec within .16 ft/sec accuracy. 1 part in 50,000.

Note: This position on test platform will be used for an accelerometer test item when testing accelerometers.

(c) One star tracker to measure azimuth orientation while in flight to within ± 10 sec.

(3) Test Specimens

(a) One accelerometer || to thrust for evaluation of S.F., $\int a^2$, $\int a^3$ terms. (This position may be used for instrumentation in testing gyroscopes.)

(b) One accelerometer 45° to thrust for evaluating bias and cross terms. This position may be used in gyro and tracker tests.

(c) Two gyroscopes, one with sensitive axis away from normal plane so that compliance terms can be verified, and one with sensitive axis in thrust plane for evaluation of unbalance terms.

(d) One star tracker as test specimen. Note: This position will be used by instrumentation tracker in gyro tests.

III. ACTUAL PROGRESS VERSUS PLANNED PROGRESS

Progress during the third month has resulted in study completion in many areas. Specifically, FSV structural layout, FM/FM and PCM telemetry layout, test item integration, trajectory analysis and the ground tracking system layout have essentially been finished. The control system effort and the analysis/simulation program are the major areas yet to be fully completed and correlated within the overall study.

Anticipating such piecemeal progress early in February, the Contractor (STL) advised AFMDC of the advantage to be gained by AFMDC in modifying the time schedule of the technical effort. It was emphasized that such a time modification would yield a more complete coalescence of the various technical efforts when merged to form the final design criteria. This recommendation was accepted by AFMDC and the contract was modified to extend the technical study effort by 15 days.

At this time, it is the contractor's strong feeling that, with the above extension, the following time schedule will be realized:

- | | | | |
|----|--------------------------------|---|---------------|
| a. | Completion of technical effort | - | 15 March 1962 |
| b. | Verbal presentation | - | 29/30 March |
| c. | Draft of final report to AFMDC | - | 15 April |
| d. | AFMDC return draft to STL | - | 10 May |
| e. | Final report to AFMDC | - | 1 June |

IV. POSSIBLE SOURCES OF DELAY TO THE STUDY EFFORT

The only foreseeable source of possible delay at this time lies in the simulation program. ICBM computation priorities could result in slippage of the GEM digital simulation program. However, it is felt that this is of no great concern and the completion date will be 15 March 1962.

1

GEM TASK LAYOUT
 DEFINE TEST PHILOSOPHY & OBJECTIVES
 ESTABLISH TEST CONDITIONS

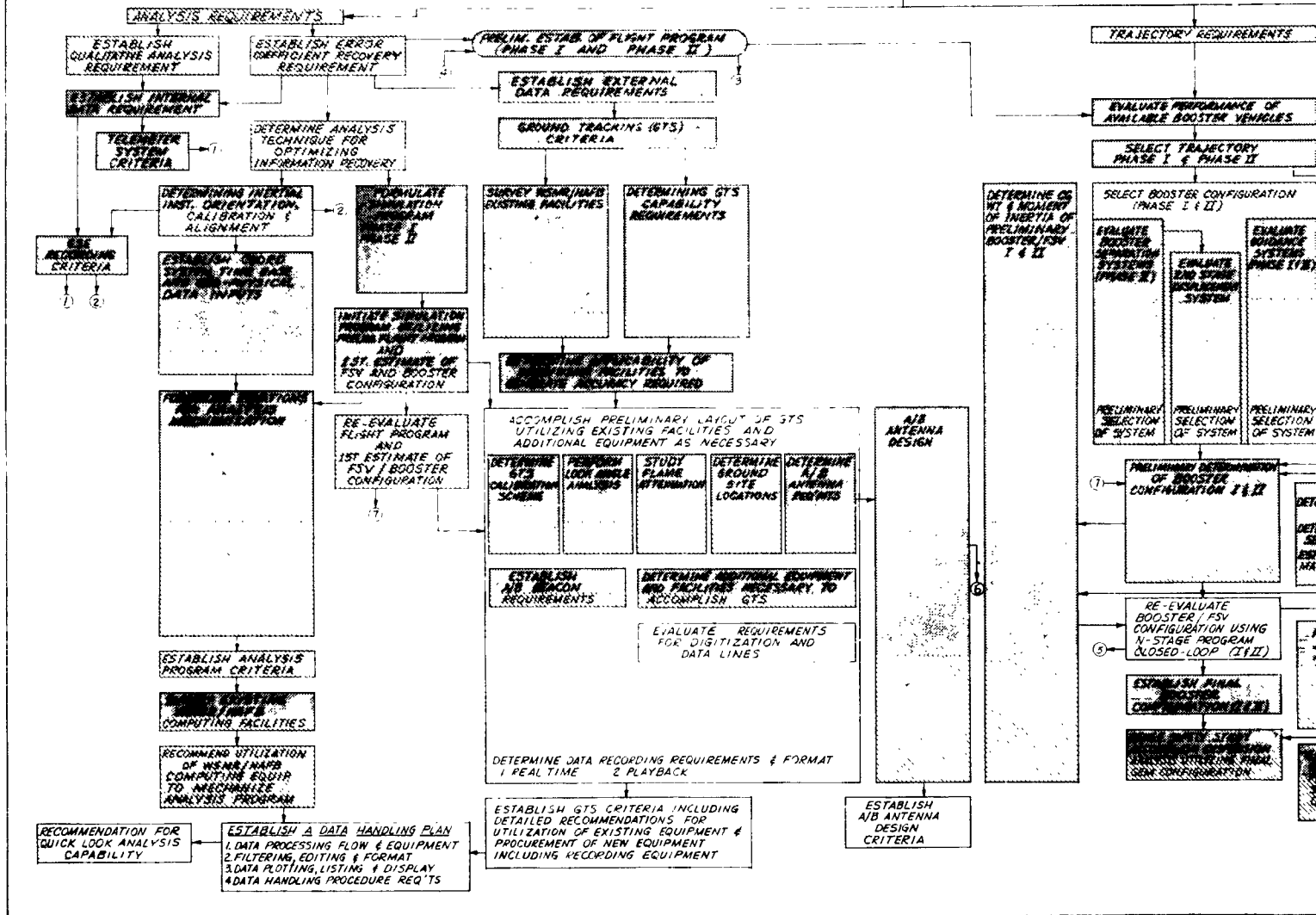

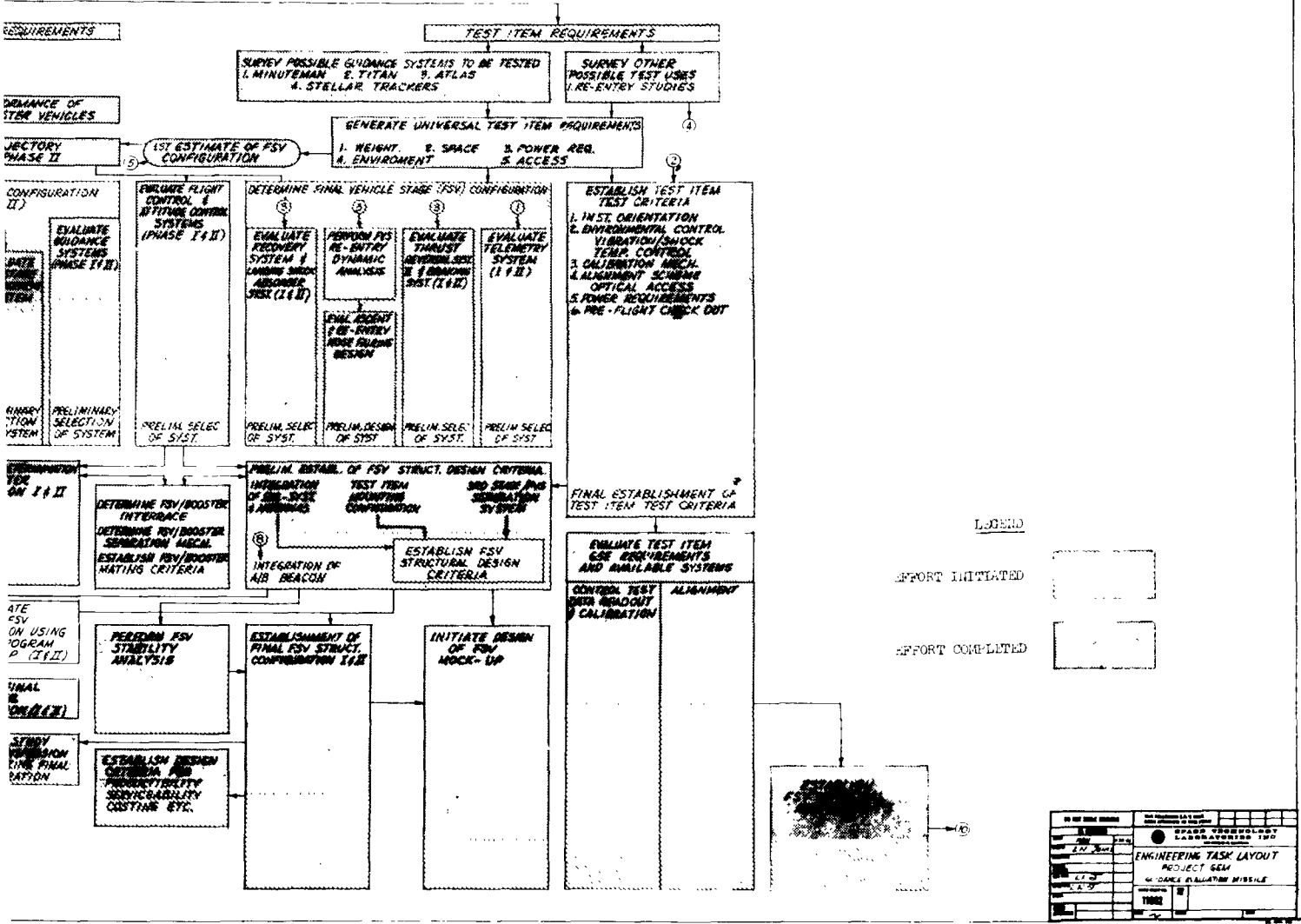

Appendix 2
TRAJECTORY ANALYSIS

APPENDIX 2

TRAJECTORY ANALYSIS

The following describes the progress of the trajectory analysis and vehicle performance evaluation which includes the changes and additions that have occurred since the last report. The basic description of the trajectories and the method of simulation is still the same and need not be repeated here.

The trajectory characteristics of the chosen vehicle (Algol II + Pershing B-2) have changed considerably from those indicated in the previous progress report. This is due to the following reasons:

1. The performance characteristics of the Algol II stage have been changed such that a gain of approximately five percent in total impulse has been achieved over that indicated previously for the Algol II. This improvement is realized in an increased thrust level and a slight increase in propellant loading through the change in the grain design, while the over-all burning time remains unchanged.
2. An increase in the payload weight (Final Stage Vehicle) to 1,374 pounds from the previously assumed 1,000 pounds has taken place due to better estimates of the requirements for tracking, parachutes, and controls, etc.

During first stage operation, the two changes resulted in opposite effects with the increased impulse providing the greatest net performance change. As can be seen from the Phase 1A and 1B trajectory characteristics, shown in Figures 1 and 2 respectively, the maximum velocity attained during first stage burning is now 8,025 ft/sec which is a gain of approximately 450 ft/sec over the previous performance results. Also, the maximum sensed acceleration has increased to 11.5 g's, thus providing better conditions for guidance error separation.

The increased weight of the FSV degrades somewhat the acceleration of the B-2 stage and thus reduces the velocity addition of this stage. However, the general shape of the two trajectories is still the same. The Phase 1A trajectory has a higher apogee altitude than the previous trajectories due to the increased Algol performance and an increased coast time to 20 seconds between Algol burnout and B-2 ignition. The higher altitude and reduced B-2 capability results in higher re-entry conditions; the maximum acceleration approaching 10 g's. Since the re-entry phase is part of the testing environment, the increased acceleration level is desirable. For the Phase 1B trajectory, the increased performance results in a 19 nautical mile higher apogee altitude before B-2 ignition than was attained previously. The re-entry conditions, however, will not change because they can be adjusted by varying the altitude of B-2 ignition.

The Algol improvement does, however, increase the re-entry conditions for the abort case (B-2 does not fire) such that the maximum acceleration level is approximately 21.3 g's and the maximum dynamic pressure is 2619 pounds per square foot. This could be a problem area in terms of intact test item recovery. The re-entry phase of the abort trajectory is shown in Figure 3.

The two changes in vehicle characteristics caused slight modifications in the pitch programs of both phases. The Phase 1A pitch program as described in the previous progress report follows essentially the same time sequence, just the magnitude of the rates have been altered. These rates are shown in Table 1. The sequence of the pitch program for the Phase 1B trajectory has changed from that considered previously. The first stage powered flight phase is the same as the Phase 1A. During the coast phase before B-2 ignition, however, the vehicle is held at constant attitude (zero pitch rate) to lower the control gas requirements. The pitch rate for obtaining a less downrange impact location is now commanded during the B-2 burning phase. Also, a small yaw rate is commanded during the B-2 burning period to counteract the westward movement of the FSV impact location due

to the earth's rotational effects during this long flight time. The values of the second stage rates are shown in Table 1.

The instantaneous impact locations for various times during the powered flight phase are shown in Figure 4 for the nominal Phase 1A and 1B trajectories. It must be remembered that the first stage impact location corresponds very nearly to the FSV impact point if an abort due to a second stage ignition failure occurs. More exact impact locations are tabulated in Table 2.

Of particular interest during the trajectory phase are the tracking characteristics of several radar, interferometer, and PCM stations. The station locations of interest are given in Table 3. The parameters that define the tracking characteristics are as follows:

1. Slant Range - the line-of-sight range between the tracking station and the vehicle.
2. Look Angle 1 - Angle between the vehicle axis and the tracking station line-of-sight.
3. Look Angle 2 - Angle between the yaw axis and the projection of radar line-of-sight on a plane perpendicular to the vehicle's centerline. From the rear of the vehicle, the angle is measured clockwise from the yaw axis.
4. Elevation Angle - Angle between the station vertical and the station line-of-sight to the vehicle.

Plots of these parameters for the stations listed and both trajectories are presented in Figures 5 through 28. These parameters are being used to evaluate the tracking and antenna performance for both phases.

Due to the large change in the trajectory characteristics, the dispersion study to evaluate the effects of off-nominal engine performance has just begun. It is apparent, however, that the impact dispersions will be relatively small due to the low sensitivity of impact range to velocity and angular variances of lofted trajectories.

A special trajectory run was made wherein the B-2 stage was fired upward immediately subsequent to first stage burnout. This trajectory is to be studied for possible use in range instrumentation calibration. Such a scheme would make use of the output of an A/B inertial guidance unit and free flight ballistic trajectory conditions to provide a precise input for the calibration of the ground tracking system interferometer. Figure 29 is a plot of this trajectory.

TABLE 1

PITCH PROGRAM CHARACTERISTICS

Phase 1A		
Time (sec)	Event	Pitch Rate (deg/sec)
0 to 2	Algol II	0
2 to 10	Algol II	0.18
10 to 50	Algol II	0.075
50 to 60	Algol II	0
60 to 80	Coast	0
80 to 123	B-2	-0.11
123 to re-entry	Coast	0
Phase 1B		
0 to 2	Algol II	0
2 to 10	Algol II	0.18
10 to 50	Algol II	0.075
50 to 60	Algol II	0
60 to	Coast	0
to	B-2	-0.40 (yaw rate = 0.06)
to re-entry	Coast	0

TABLE 2

NOMINAL IMPACT LOCATIONS

Phase 1A		
	Latitude	Longitude
Burned-out Algol II	33.217°	-106.356°
FSV	32.622°	-106.294°
Phase 1B		
Burned-out Algol II	33.217°	-106.356°
FSV	33.050°	-106.460°

TABLE 3

TRACKING STATION LOCATIONS

FPS-16 Radar		
	Latitude	Longitude
"C" Station	32° 21.47 ft	-106° 22.16 ft
King I	32° 54.13 ft	-106° 5.92 ft
Phillip Hill	33° 26.71 ft	-106° 7.89 ft
Interferometer		
Central Station (Set #1)	32° 11.75 ft	-106° 13.6 ft
North Station	32° 23.20 ft	-106° 10.6 ft
West Station	32° 14.20 ft	-106° 26.3 ft
PCM		
Dry Site	32° 22.42 ft	-106° 19.65 ft
Long Ridge	32° 46.00 ft	-105° 44.00 ft
Jig 5	32° 21.48 ft	-106° 22.15 ft

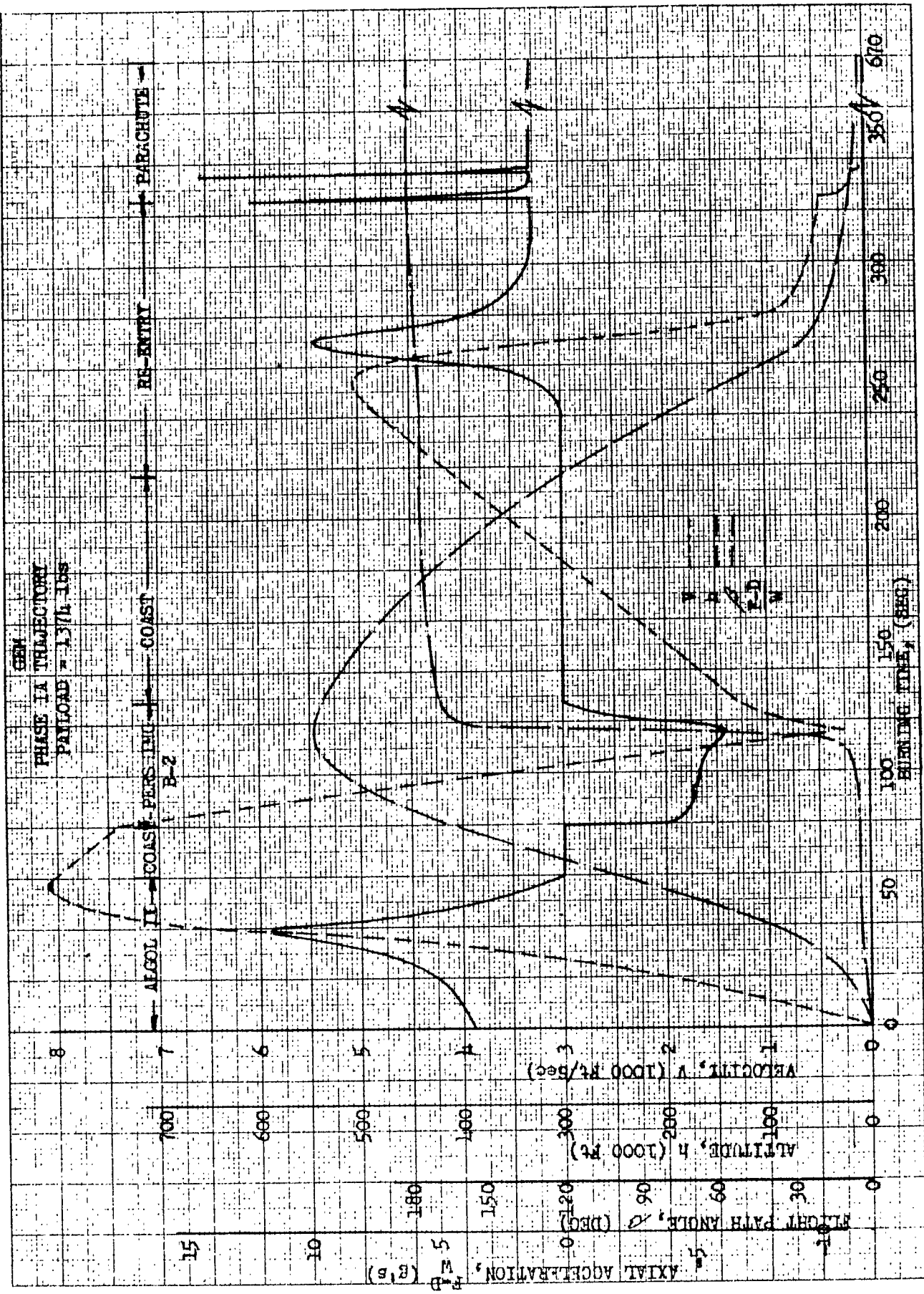

GEM

PHASE IB TRAJECTORY

PAYLOAD = 13 1/4 lbs

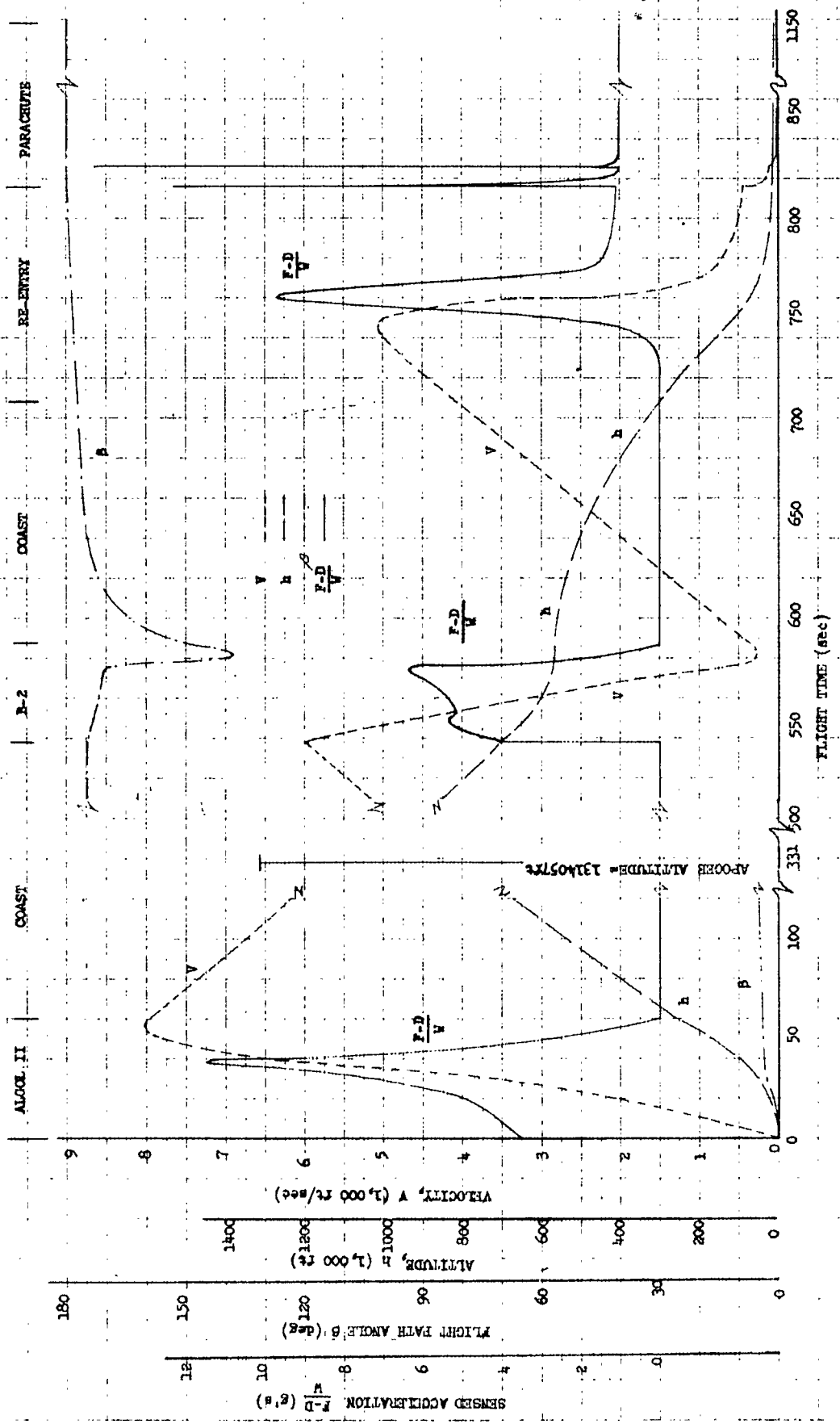

Figure 2

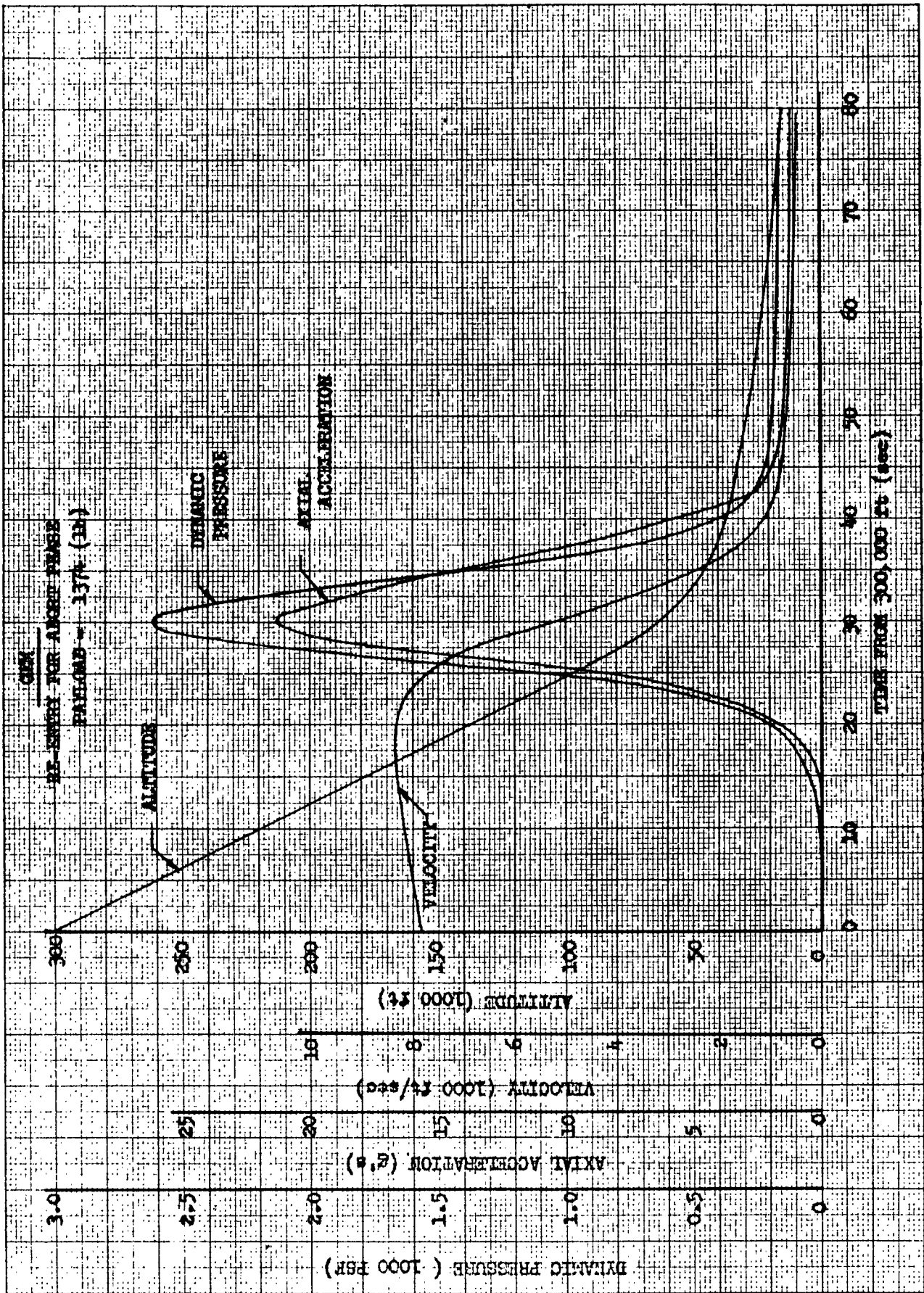
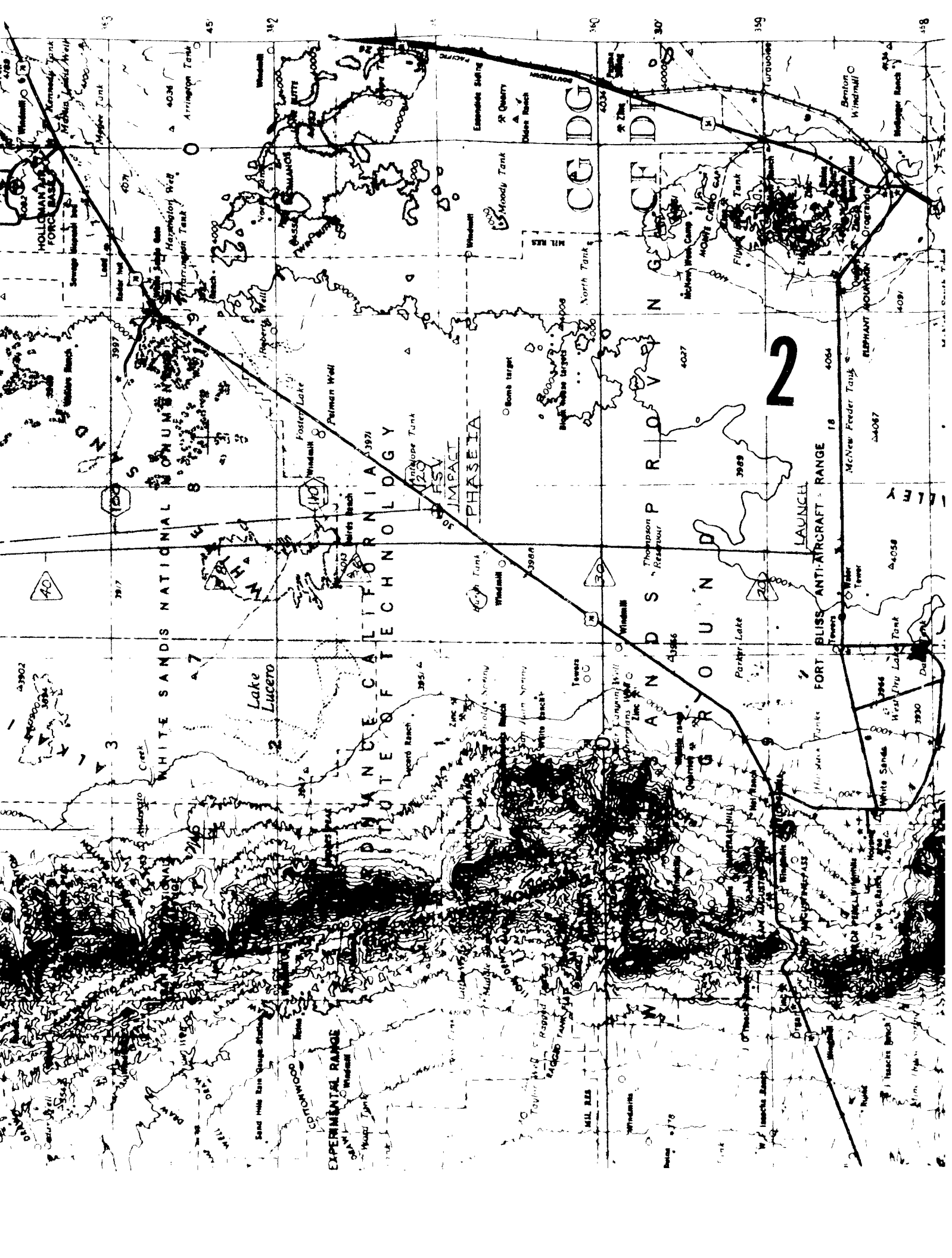

Figure 3





458

457

456

455

454

453

452

451

450

449

448

447

446

445

444

443

442

441

440

439

438

437

436

435

434

433

432

431

430

429

428

427

426

425

424

423

422

421

420

419

418

417

416

415

414

413

412

411

410

409

408

407

406

405

404

403

402

401

400

399

398

397

396

395

394

393

392

391

390

389

388

387

386

385

384

383

382

381

380

379

378

377

376

375

374

373

372

371

370

369

368

367

366

365

364

363

362

361

360

359

358

357

356

355

354

353

352

351

350

349

348

347

346

345

344

343

342

341

340

339

338

337

336

335

334

333

332

331

330

329

328

327

326

325

324

323

322

321

320

319

318

317

316

315

314

313

312

311

310

309

308

307

306

305

304

303

302

301

300

299

298

297

296

295

294

293

292

291

290

289

288

287

286

285

284

283

282

281

280

279

278

277

276

275

274

273

272

271

270

269

268

267

266

265

264

263

262

261

260

259

258

257

256

255

254

253

252

251

250

249

248

247

246

245

244

243

242

241

240

239

238

237

236

235

234

233

232

231

230

229

228

227

226

225

224

223

222

221

220

219

218

217

216

215

214

213

212

211

210

209

208

207

206

205

204

203

202

201

200

199

198

197

196

195

194

193

192

191

190

189

188

187

186

185

184

183

182

181

180

179

178

177

176

175

174

173

172

171

170

169

168

167

166

165

164

163

162

161

160

159

158

157

156

155

154

153

152

151

150

149

148

147

146

145

144

143

142

141

140

139

138

137

136

135

134

133

132

131

130

129

128

127

126

125

124

123

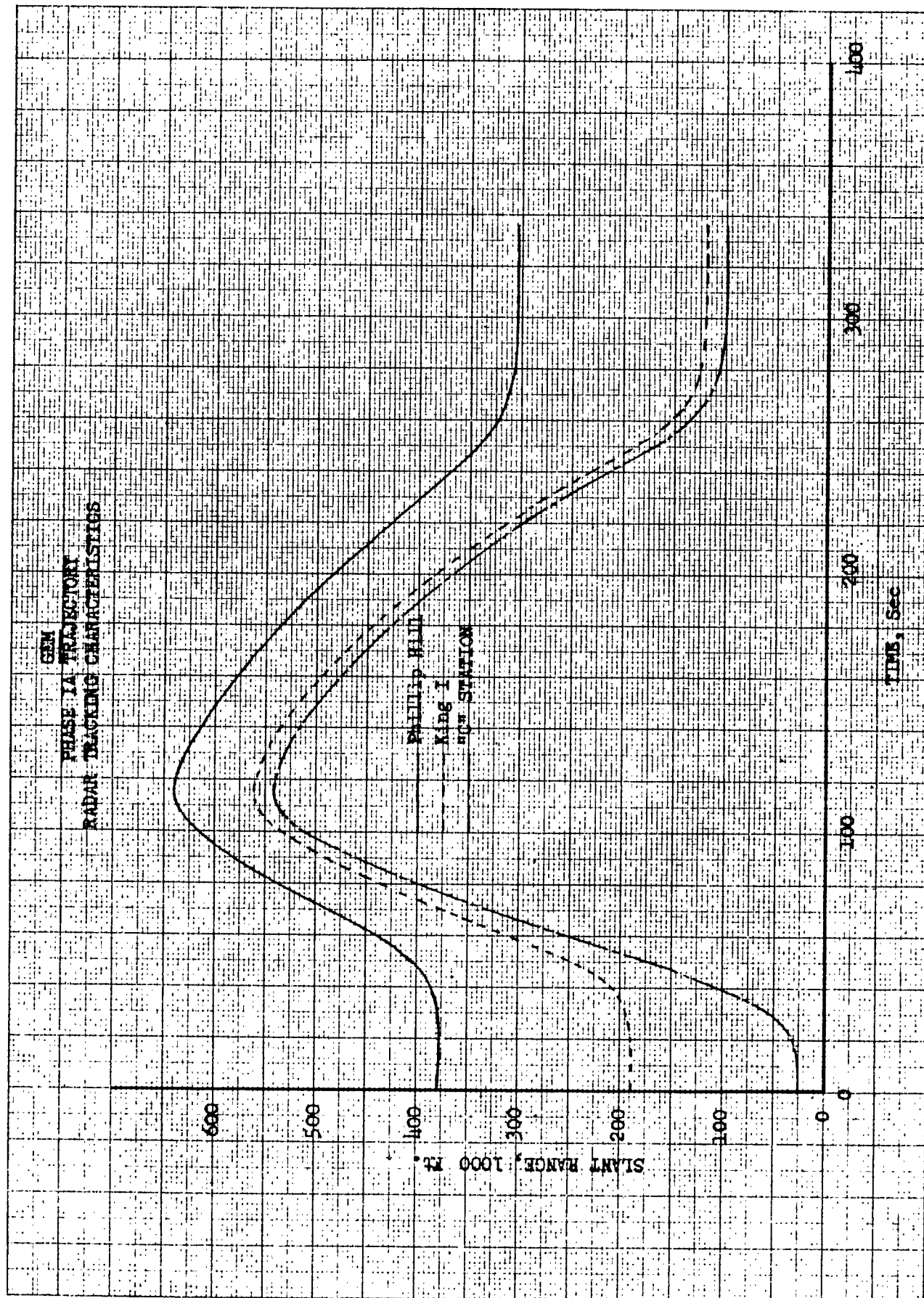

Figure 5

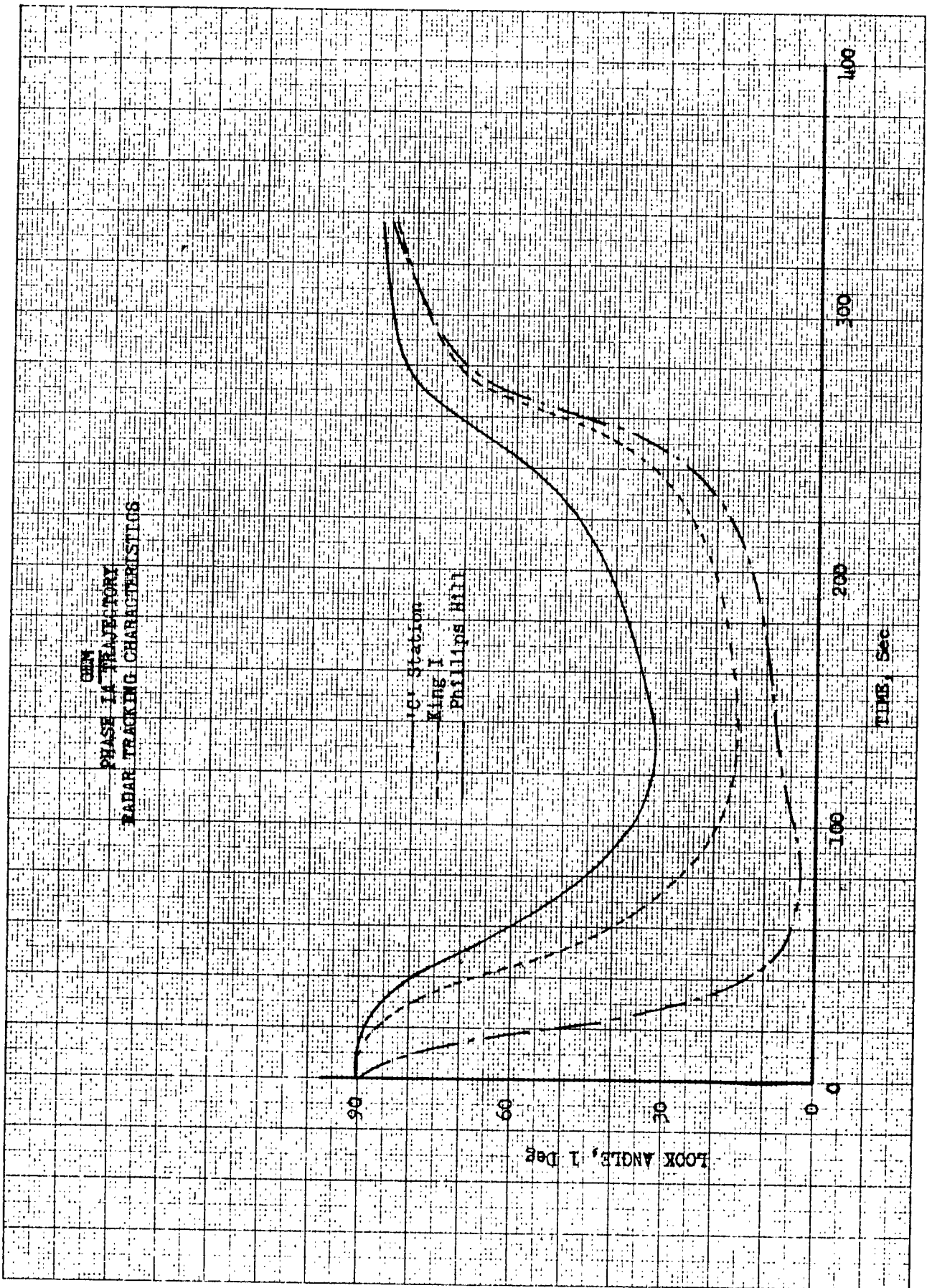

Figure 6
 . 46 .

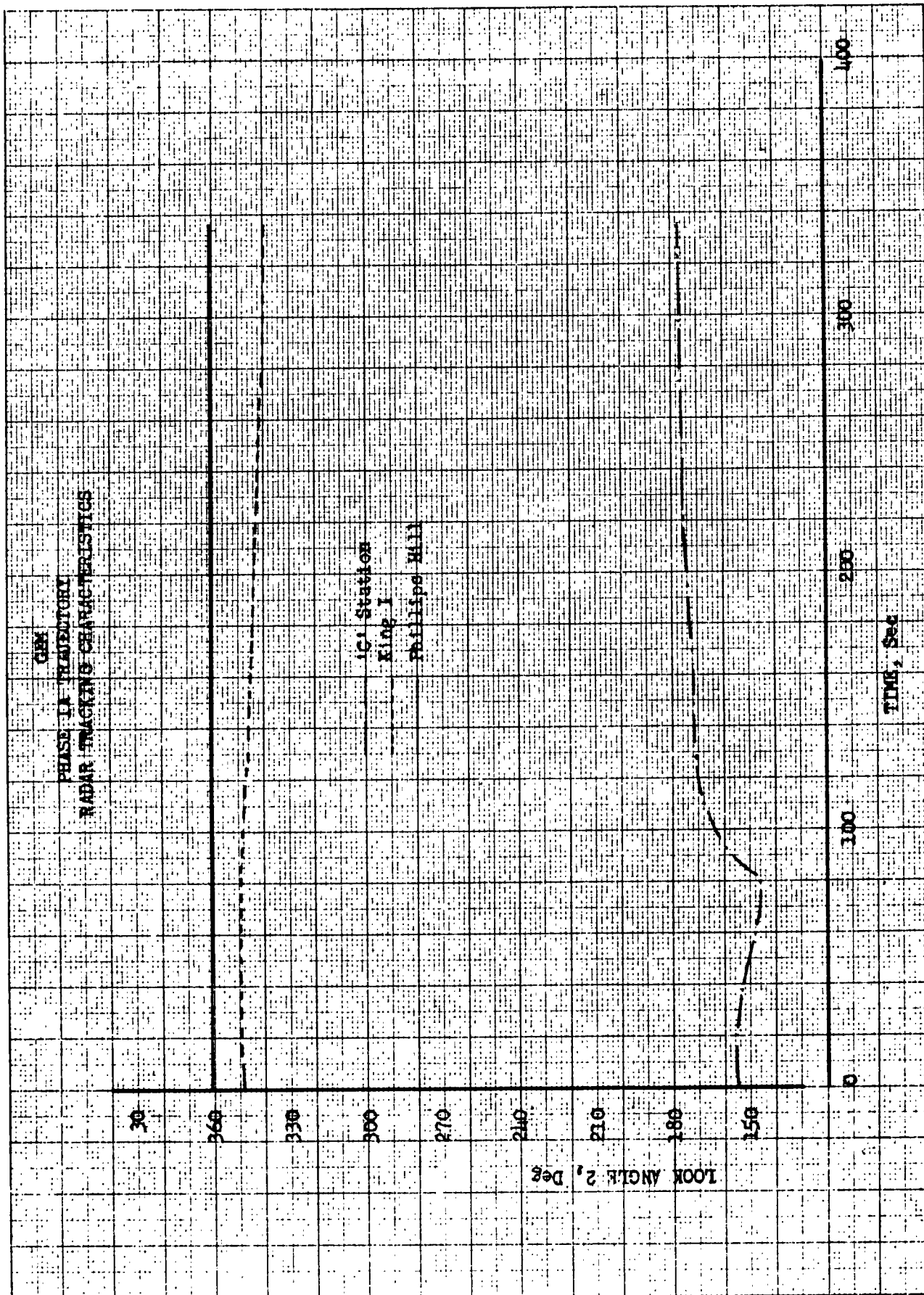

Figure 7

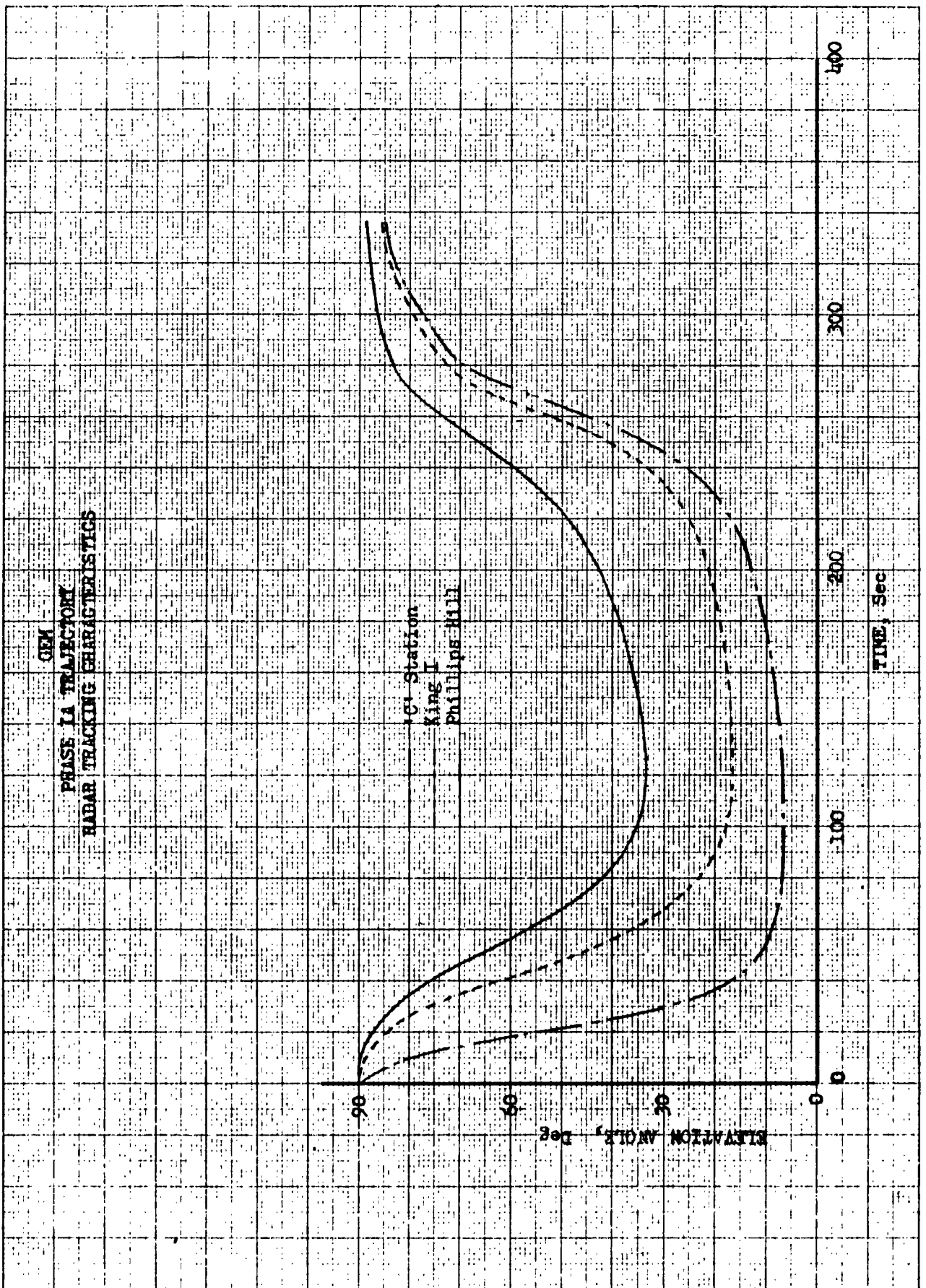

Figure 8

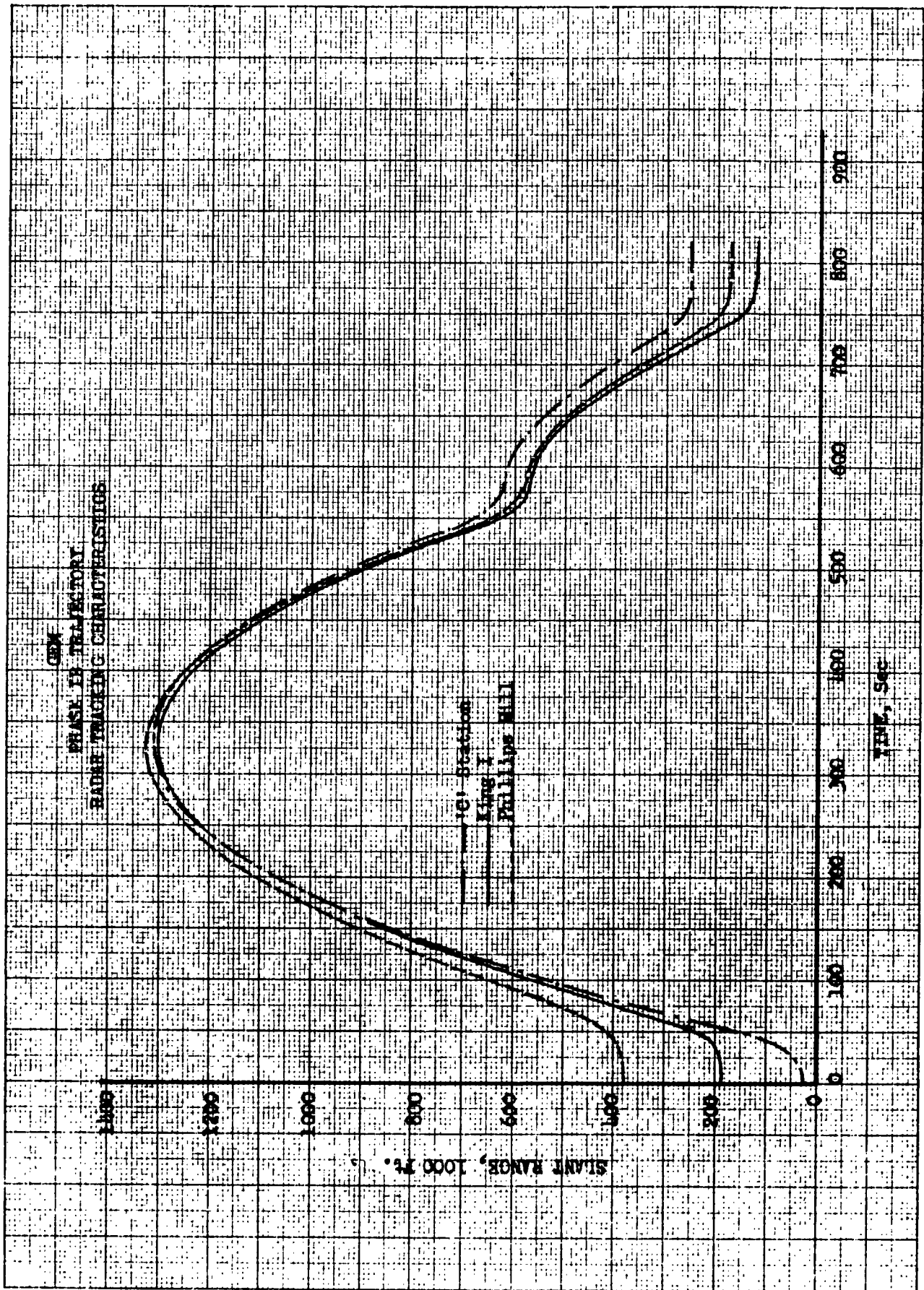

Figure 9

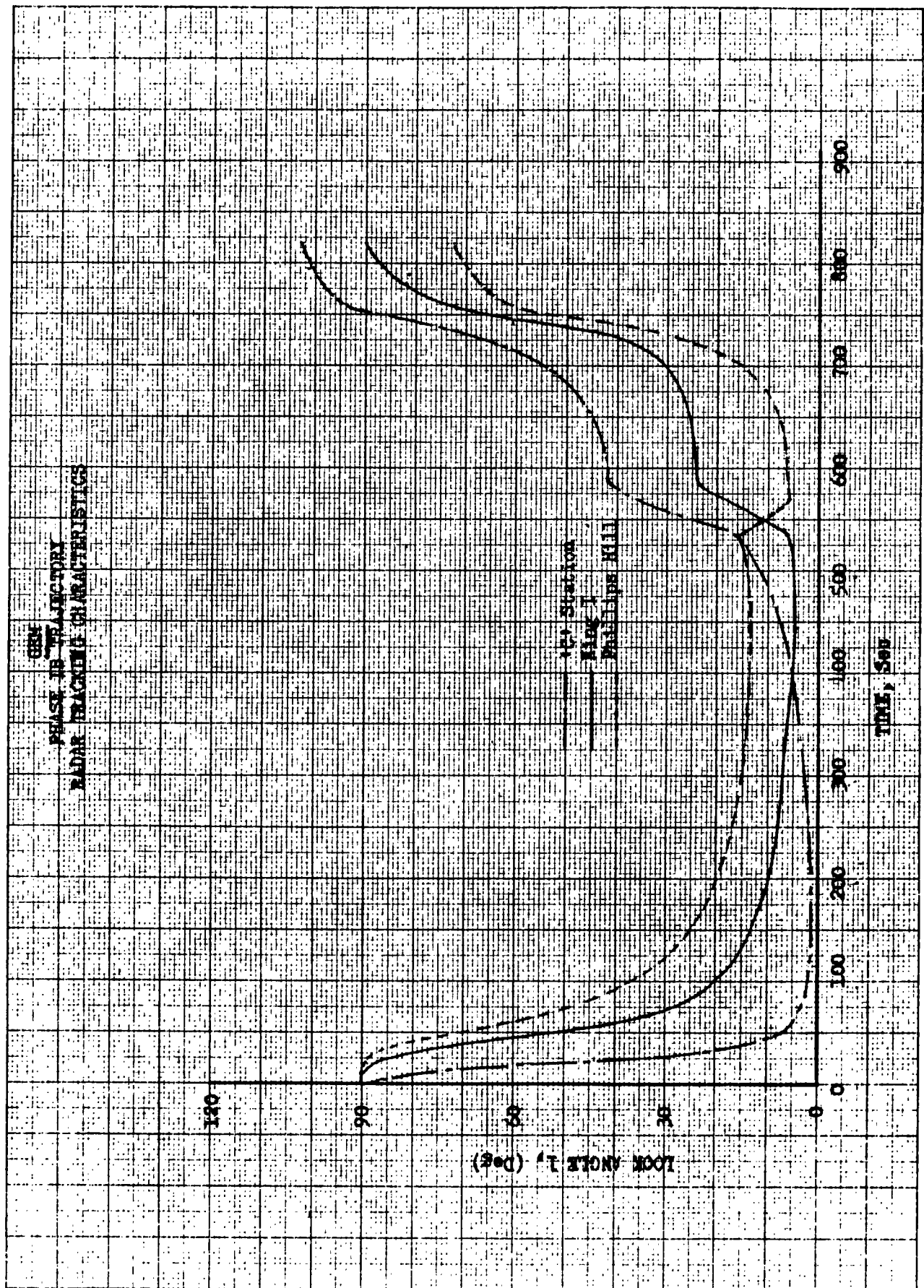

Figure 10

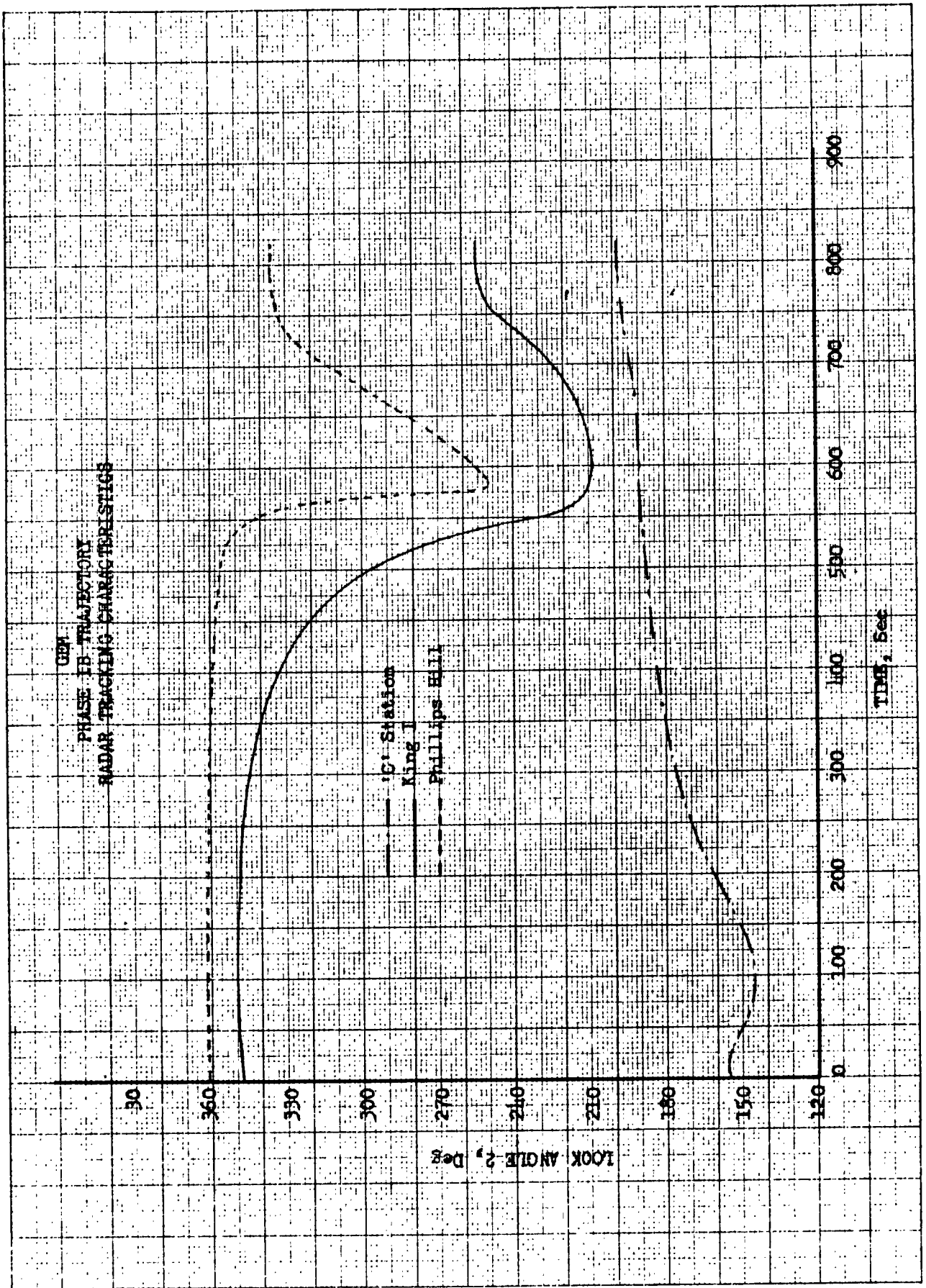

Figure 11

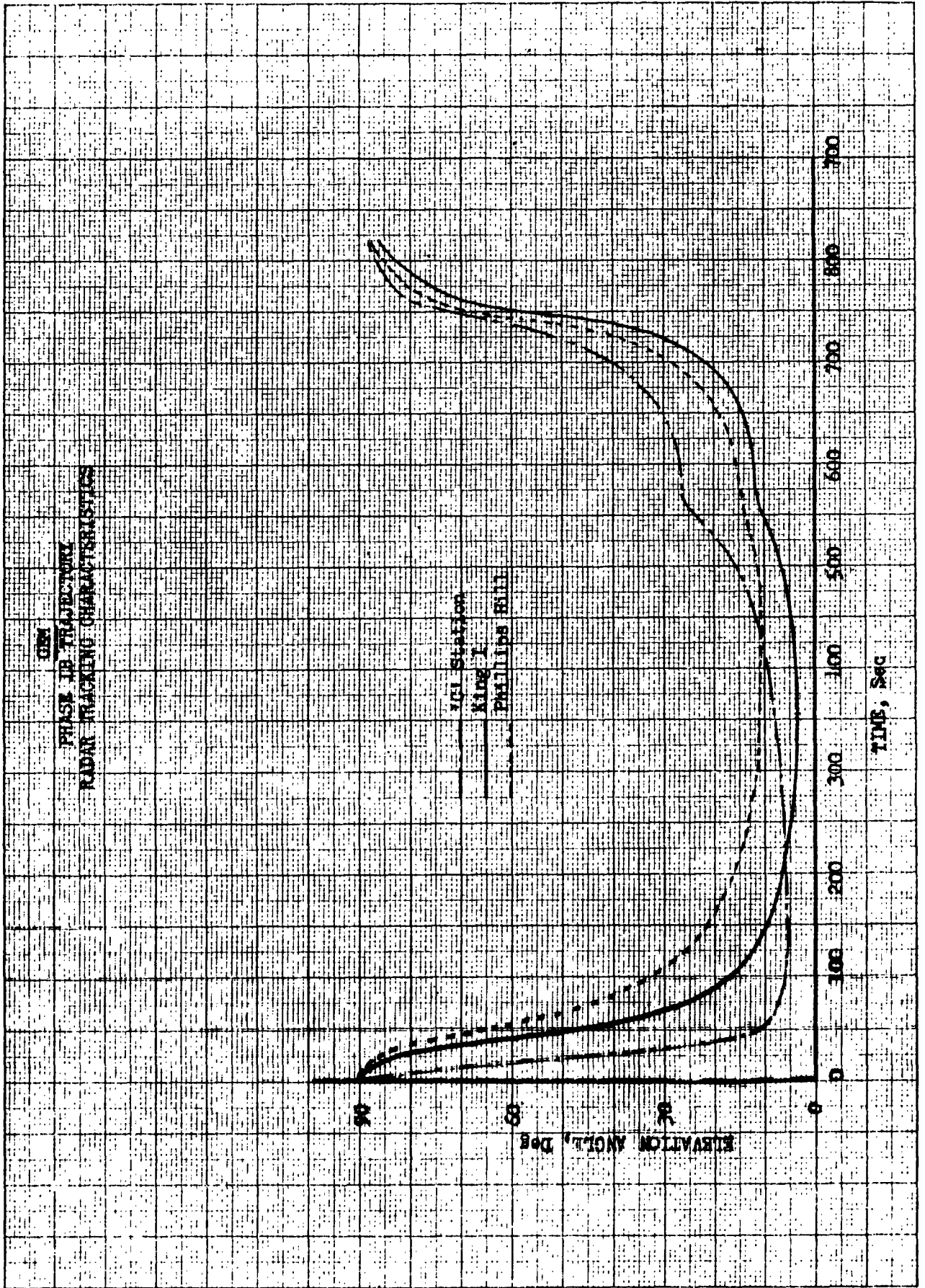

Figure 12

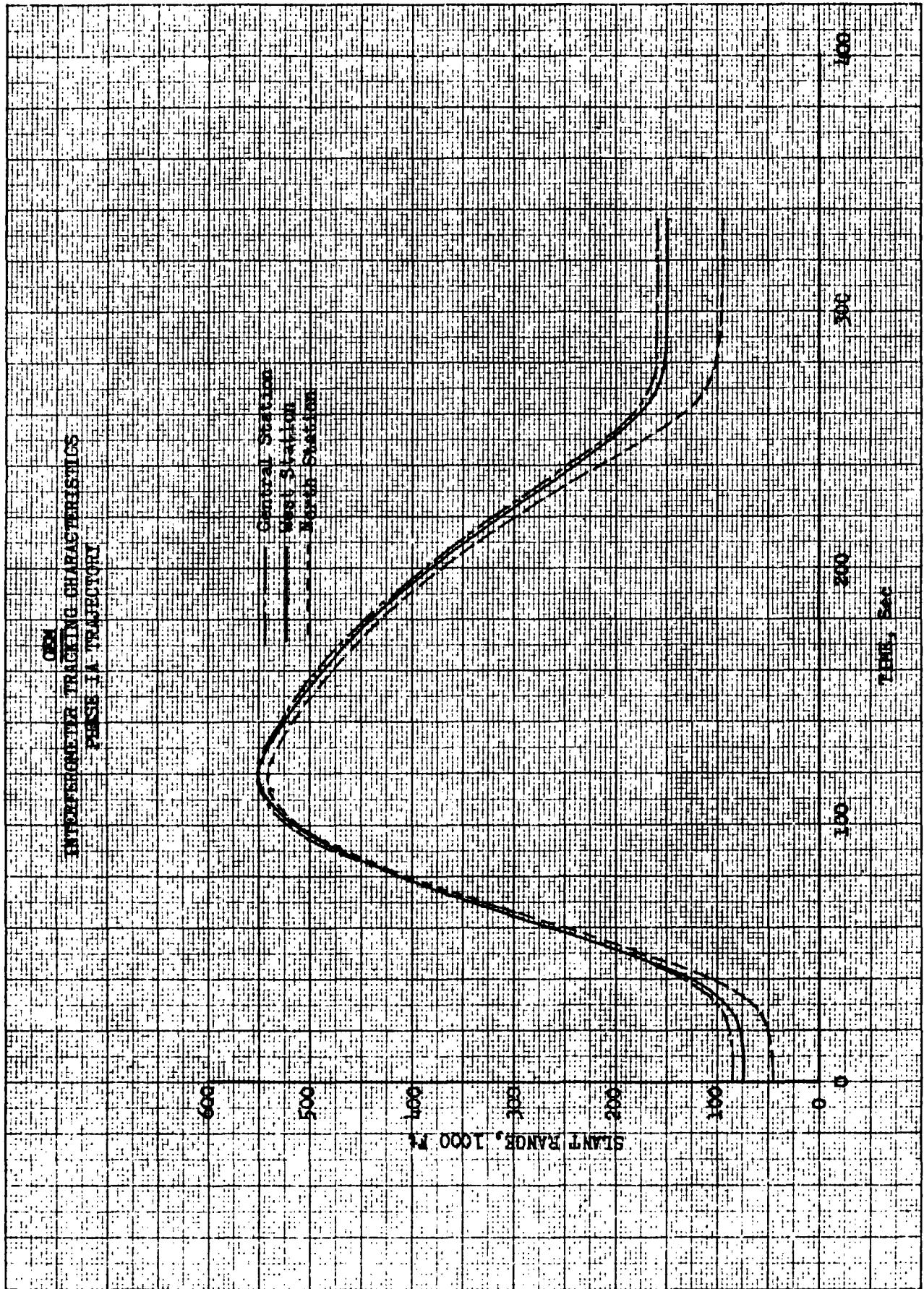

Figure 13

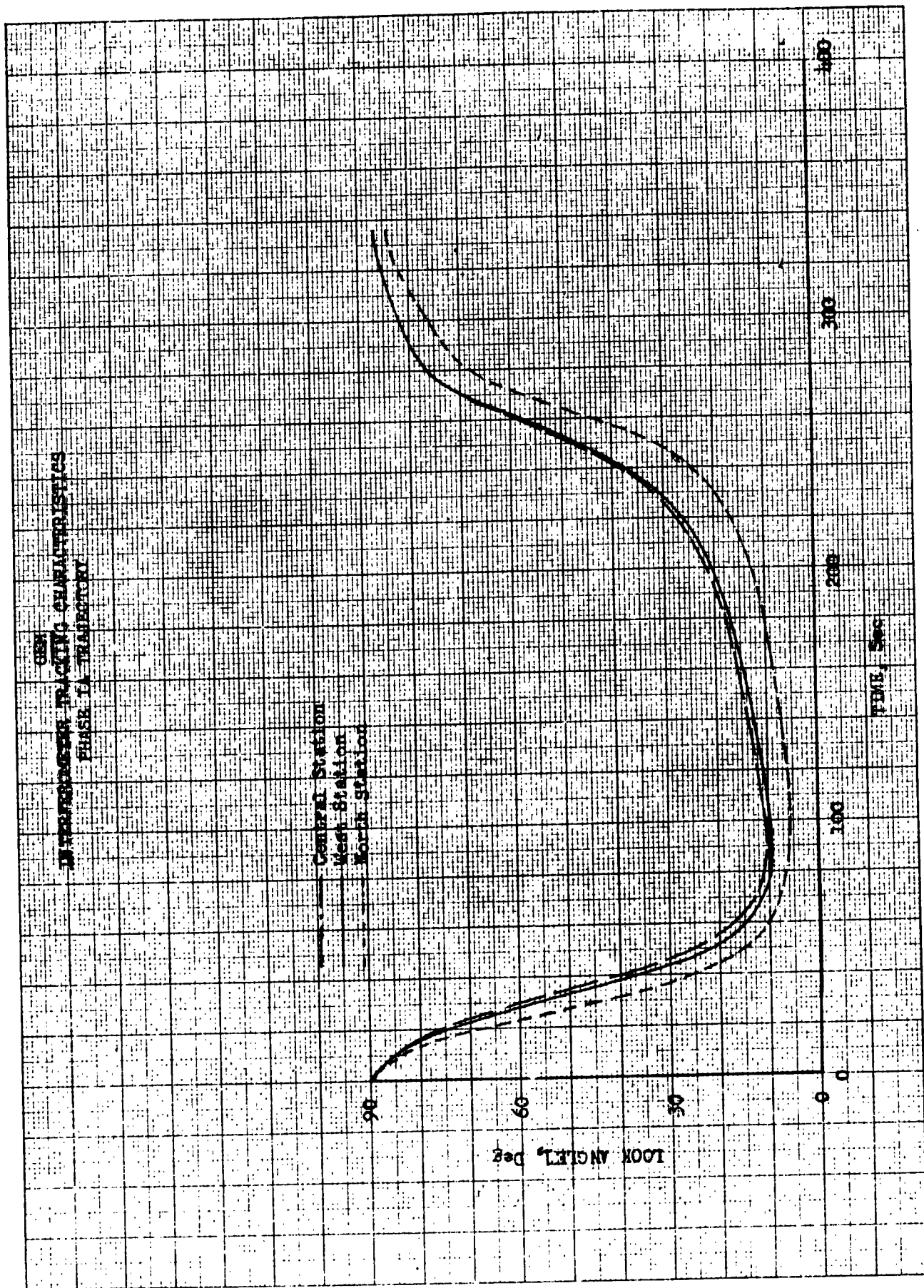

Figure 14

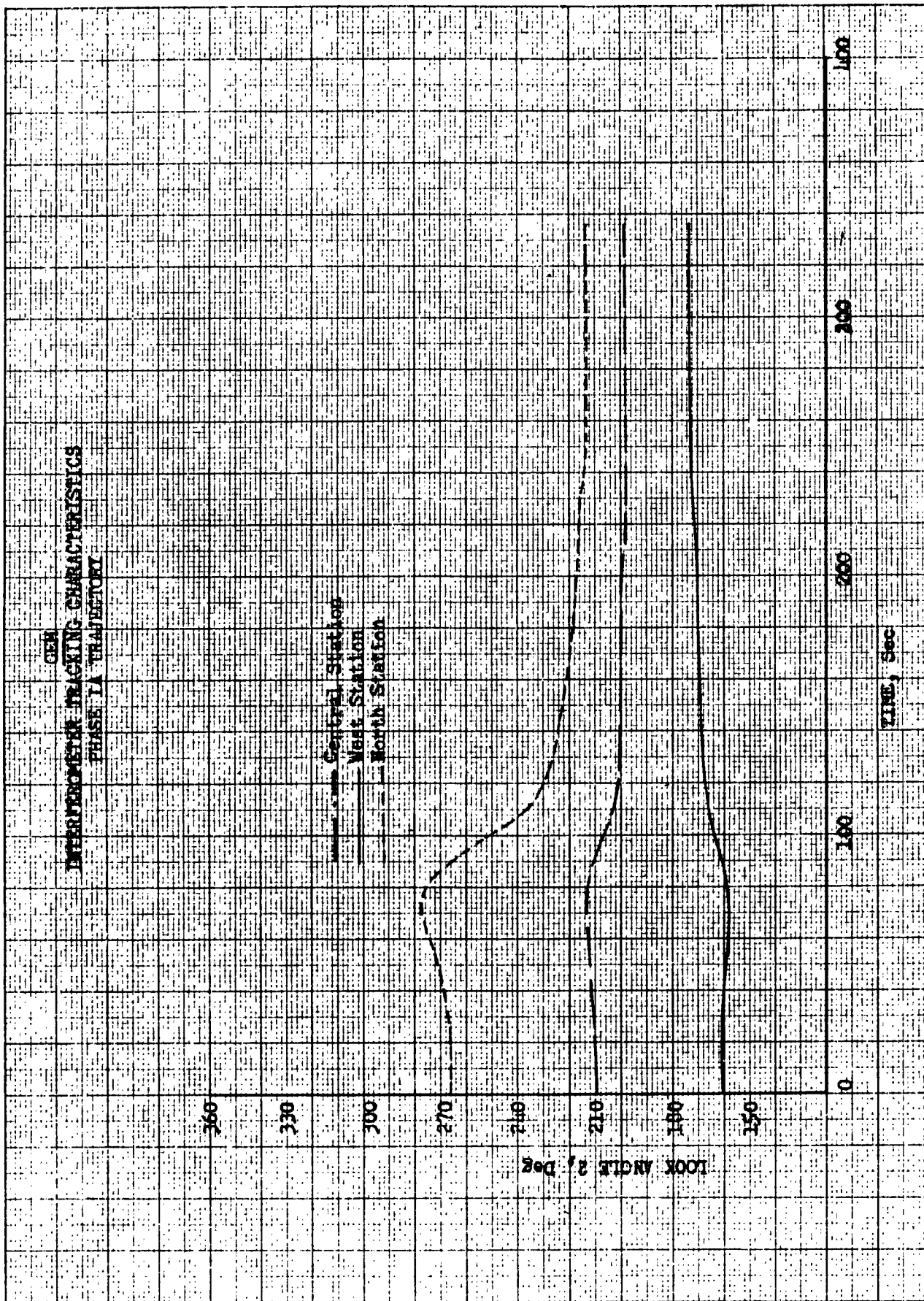

Figure 15

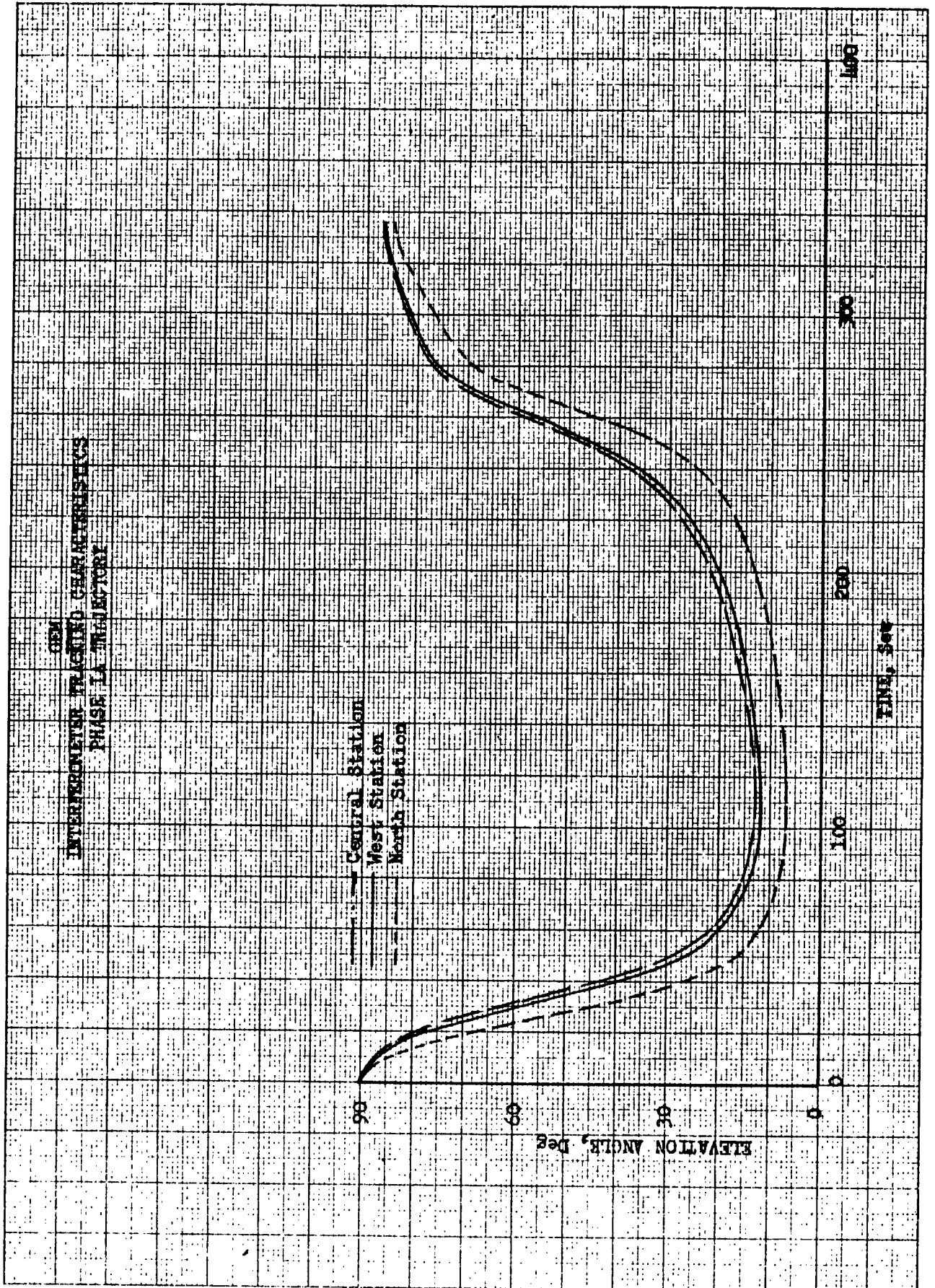

Figure 16

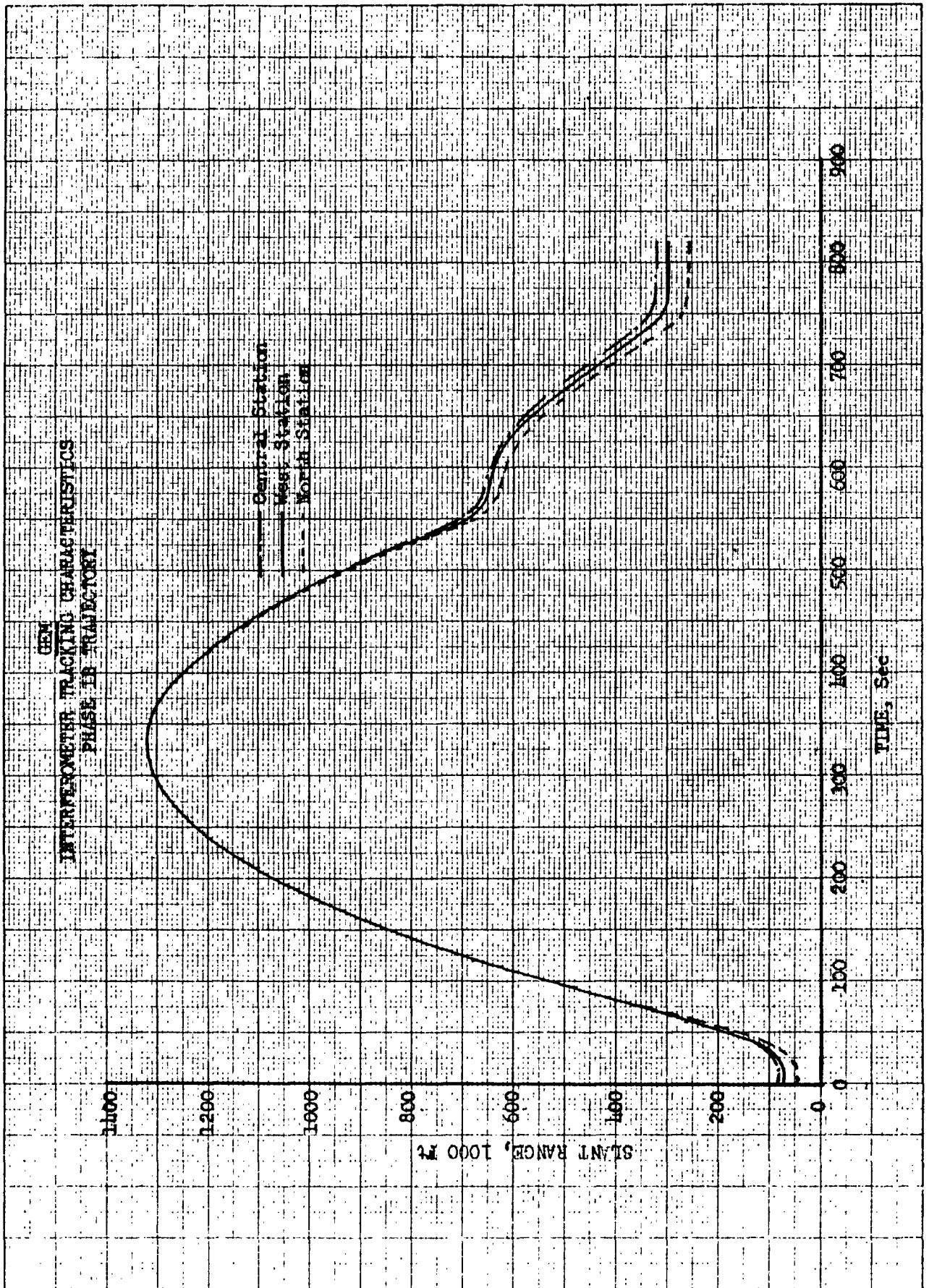

Figure 17

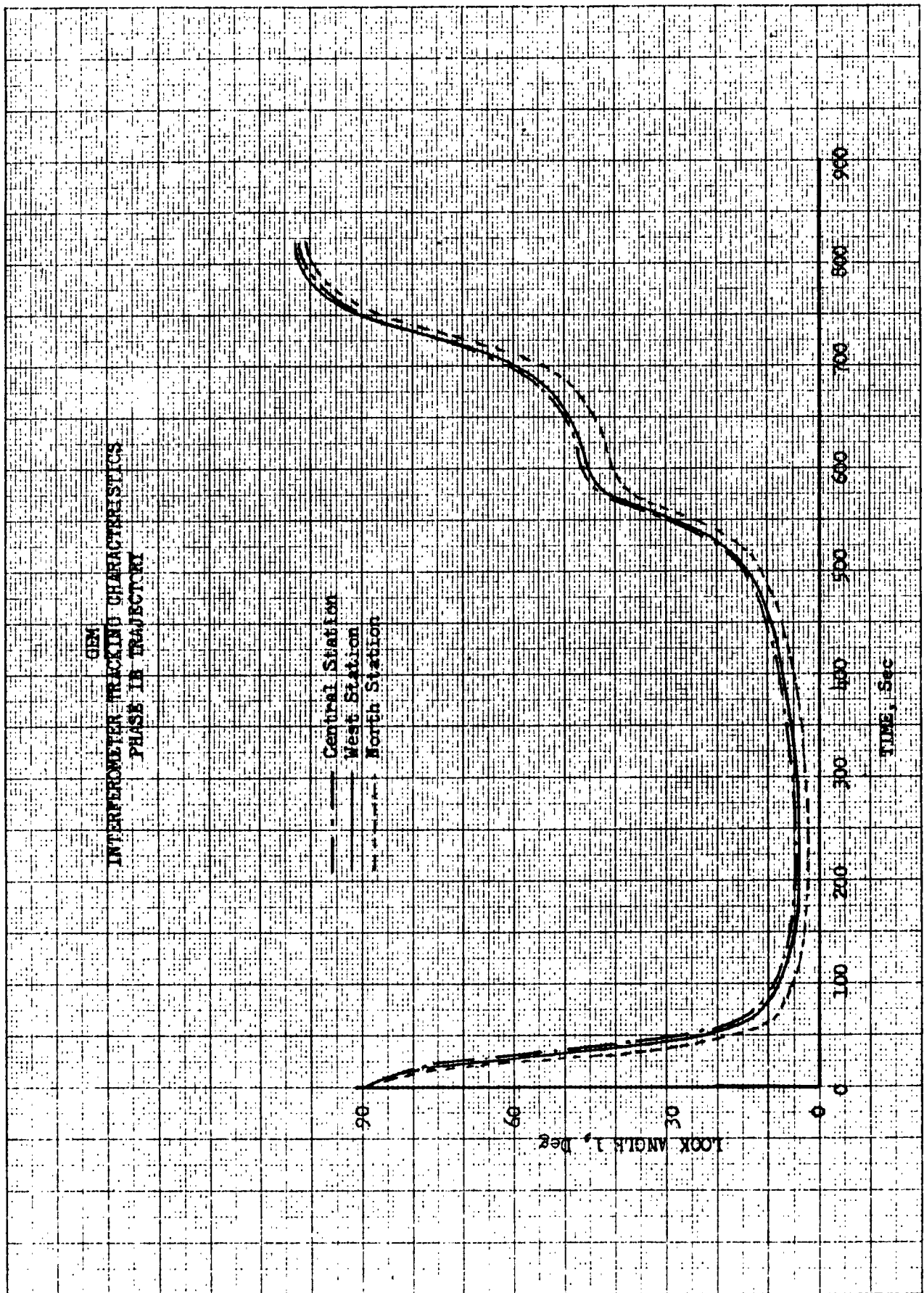

Figure 18

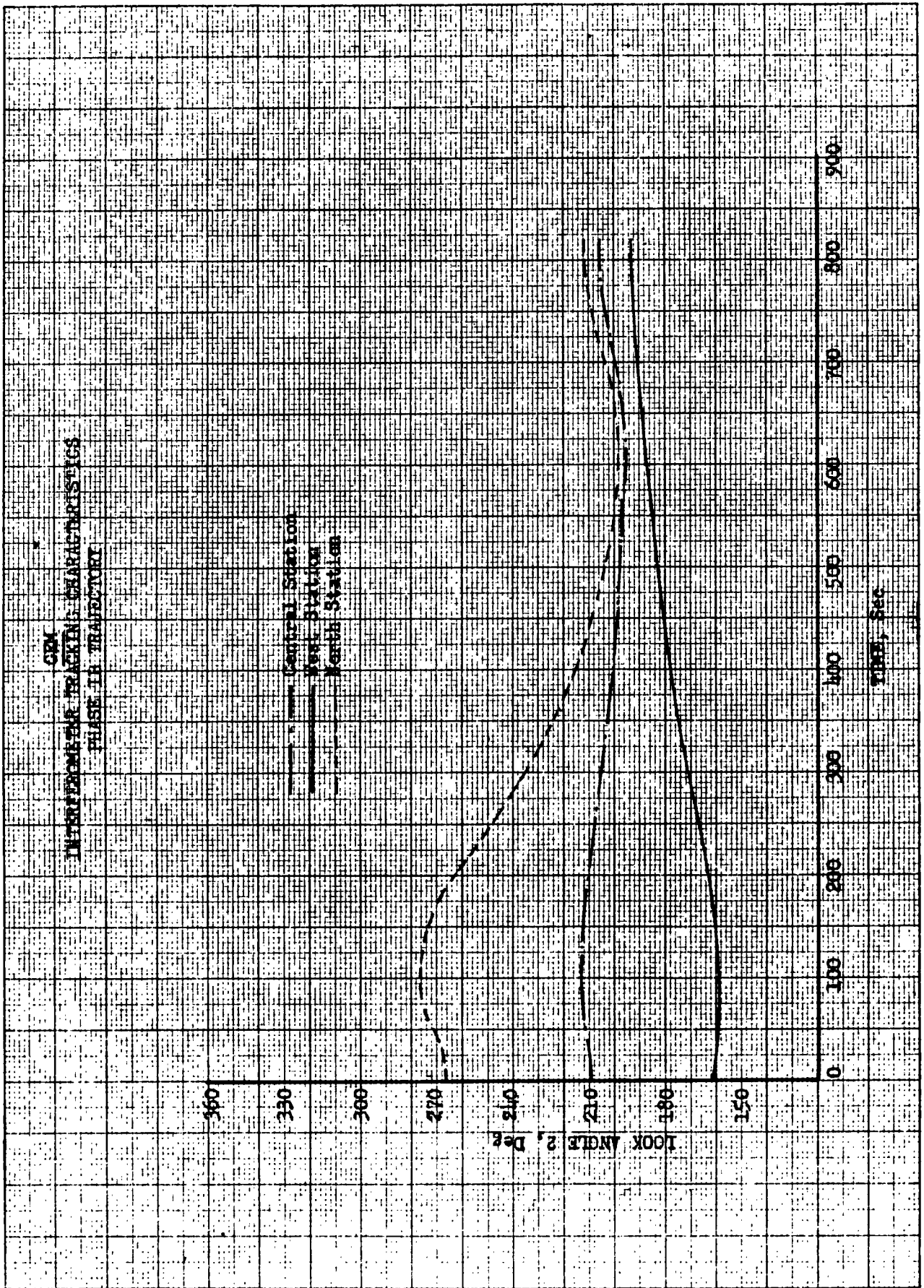

Figure 19

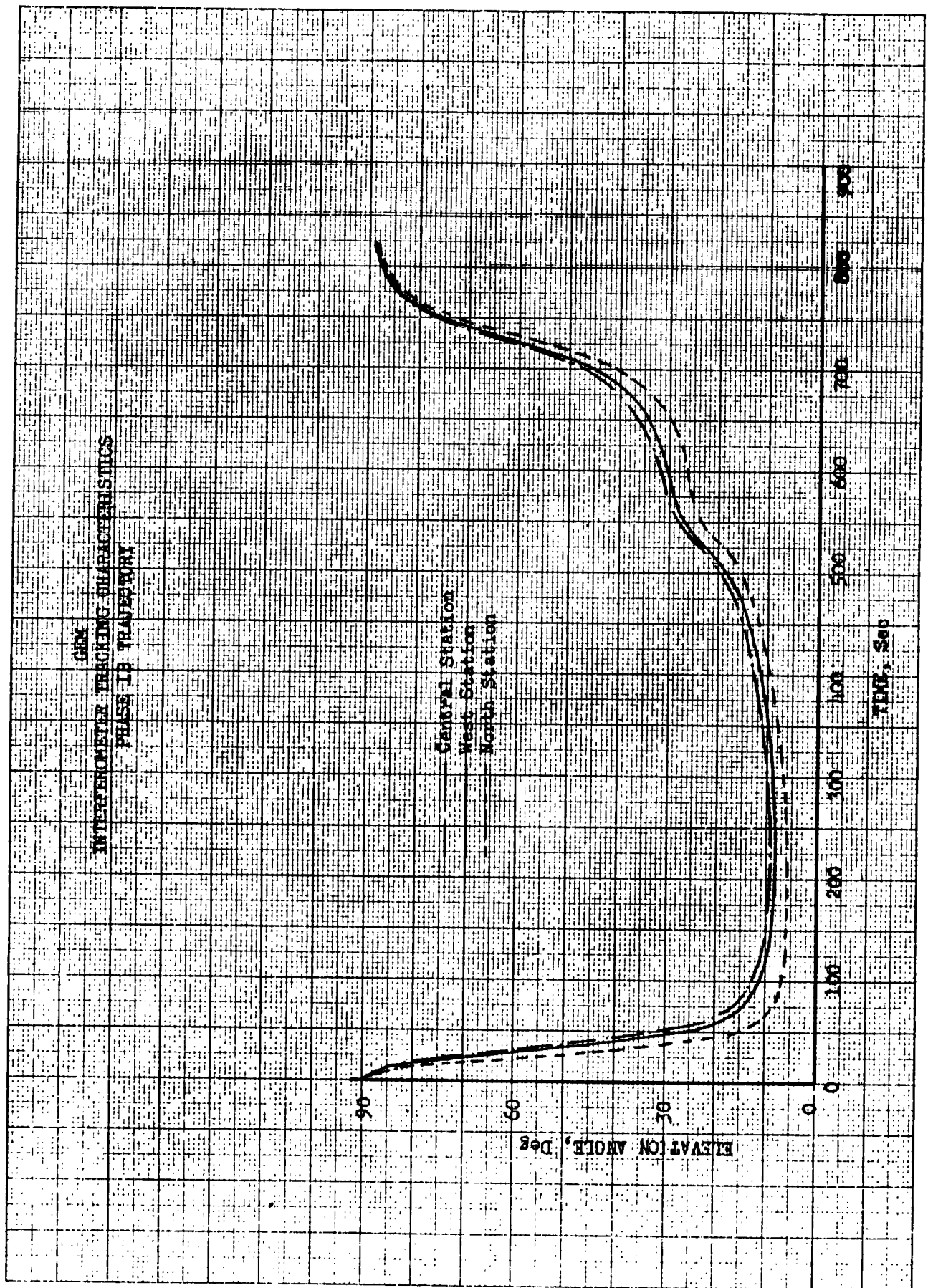

Figure 20

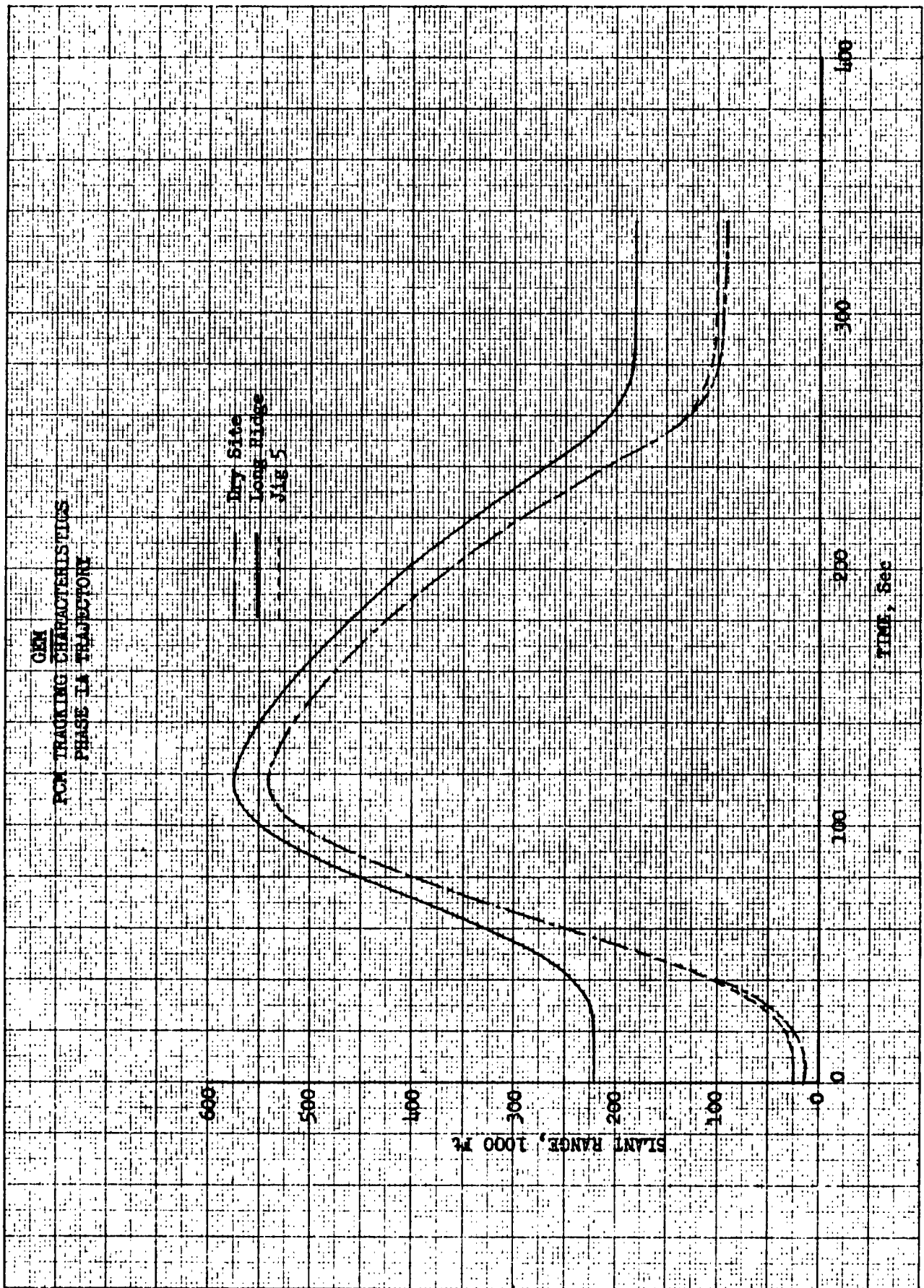

Figure 21

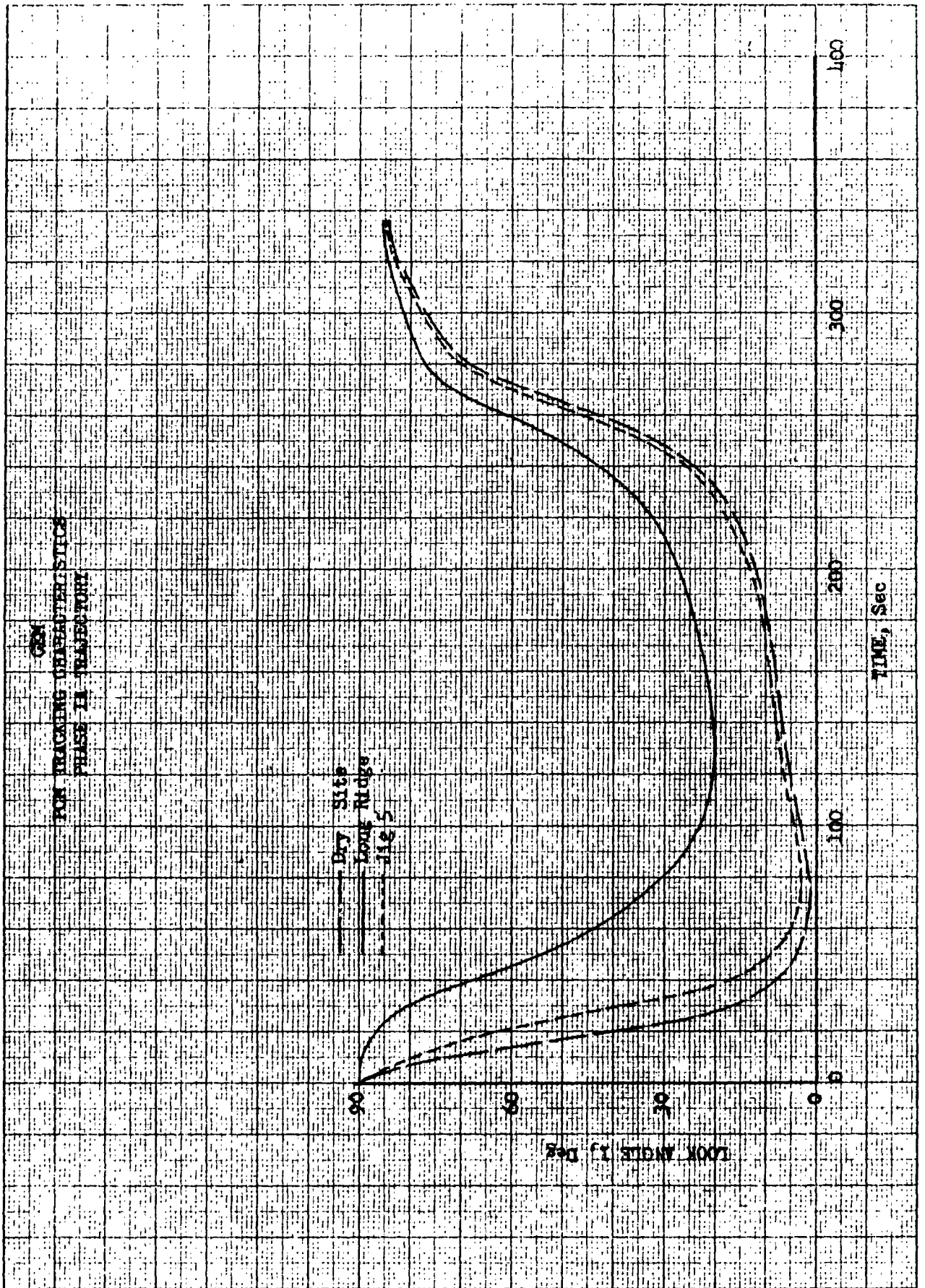

Figure 22

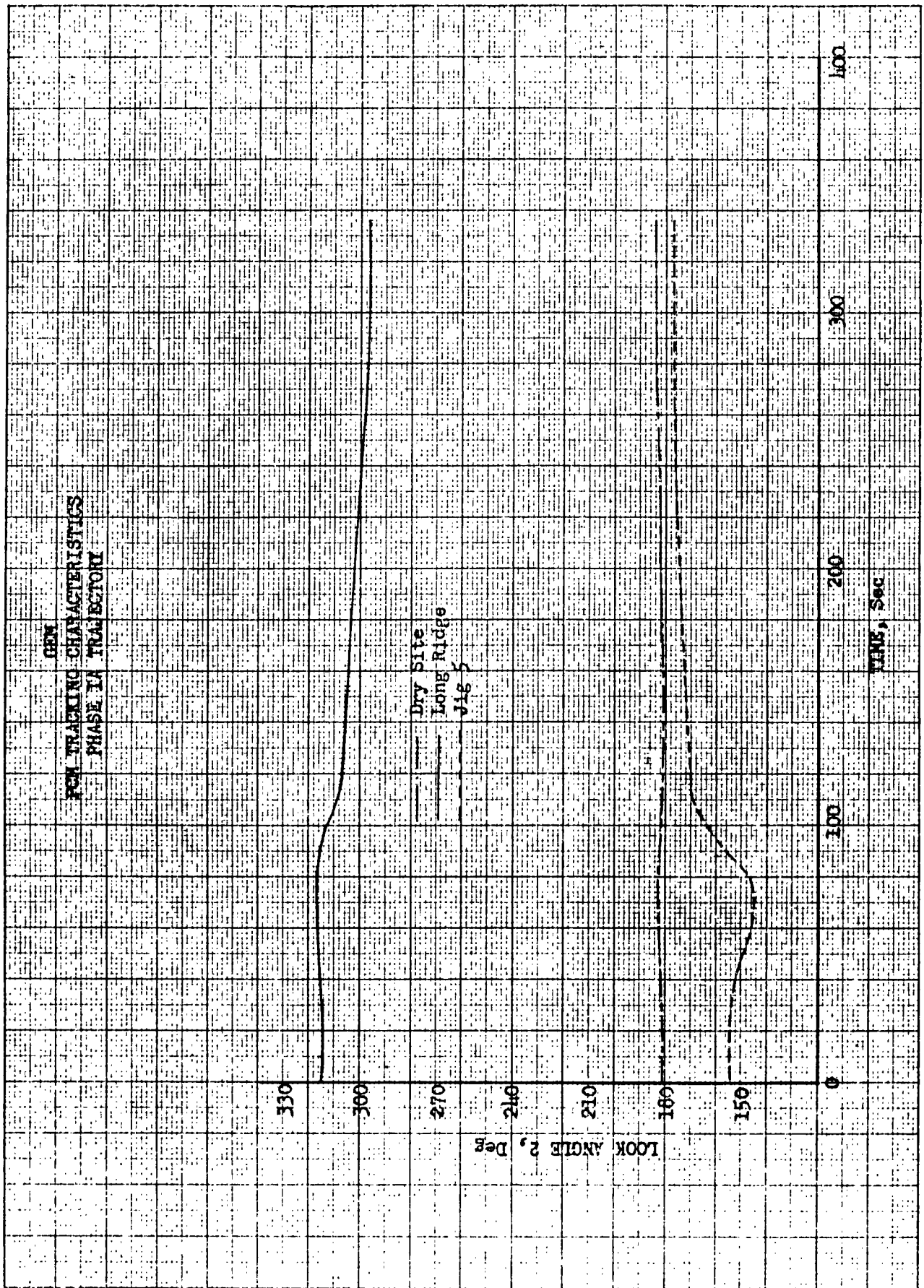

Figure 23

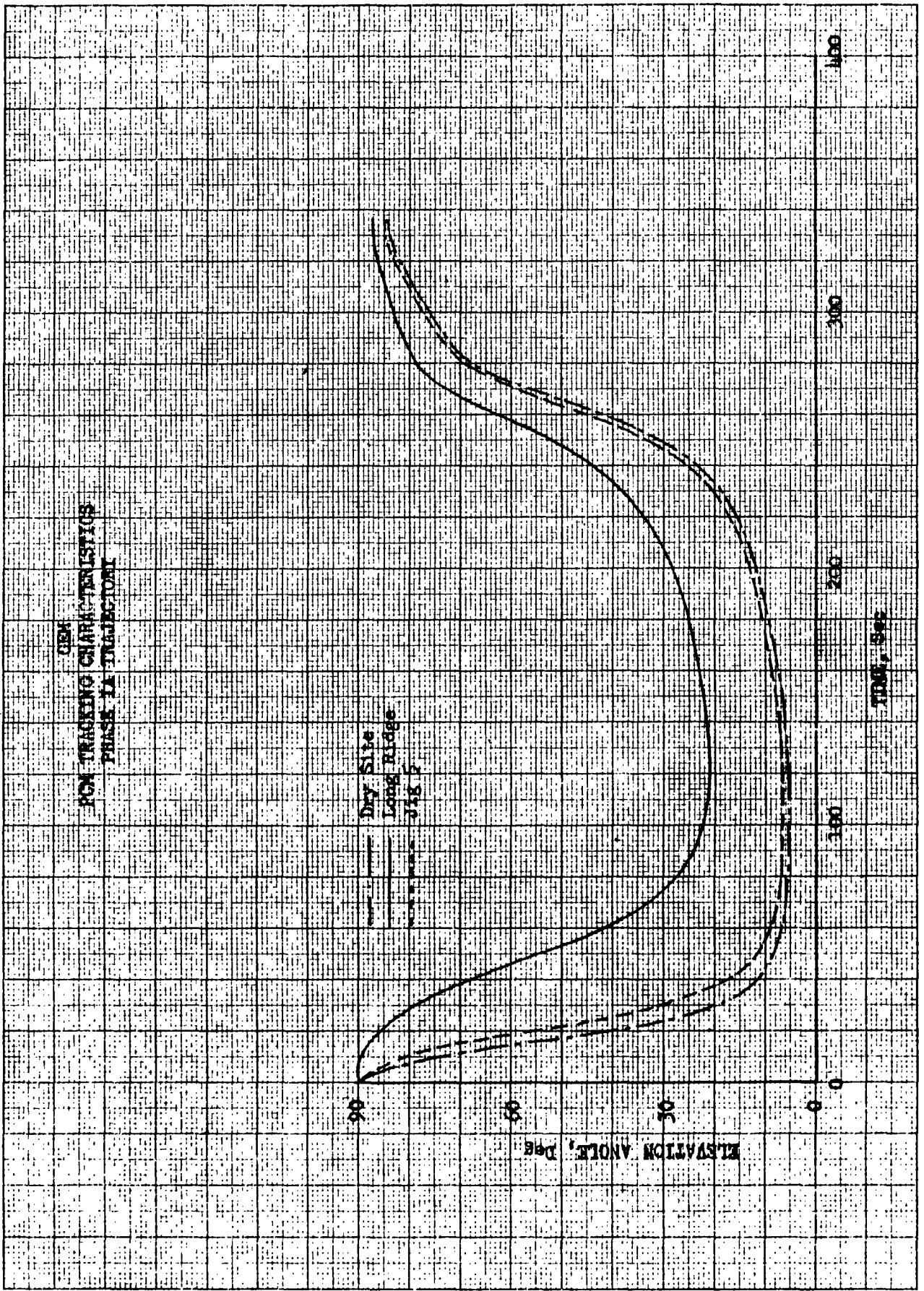

Figure 24

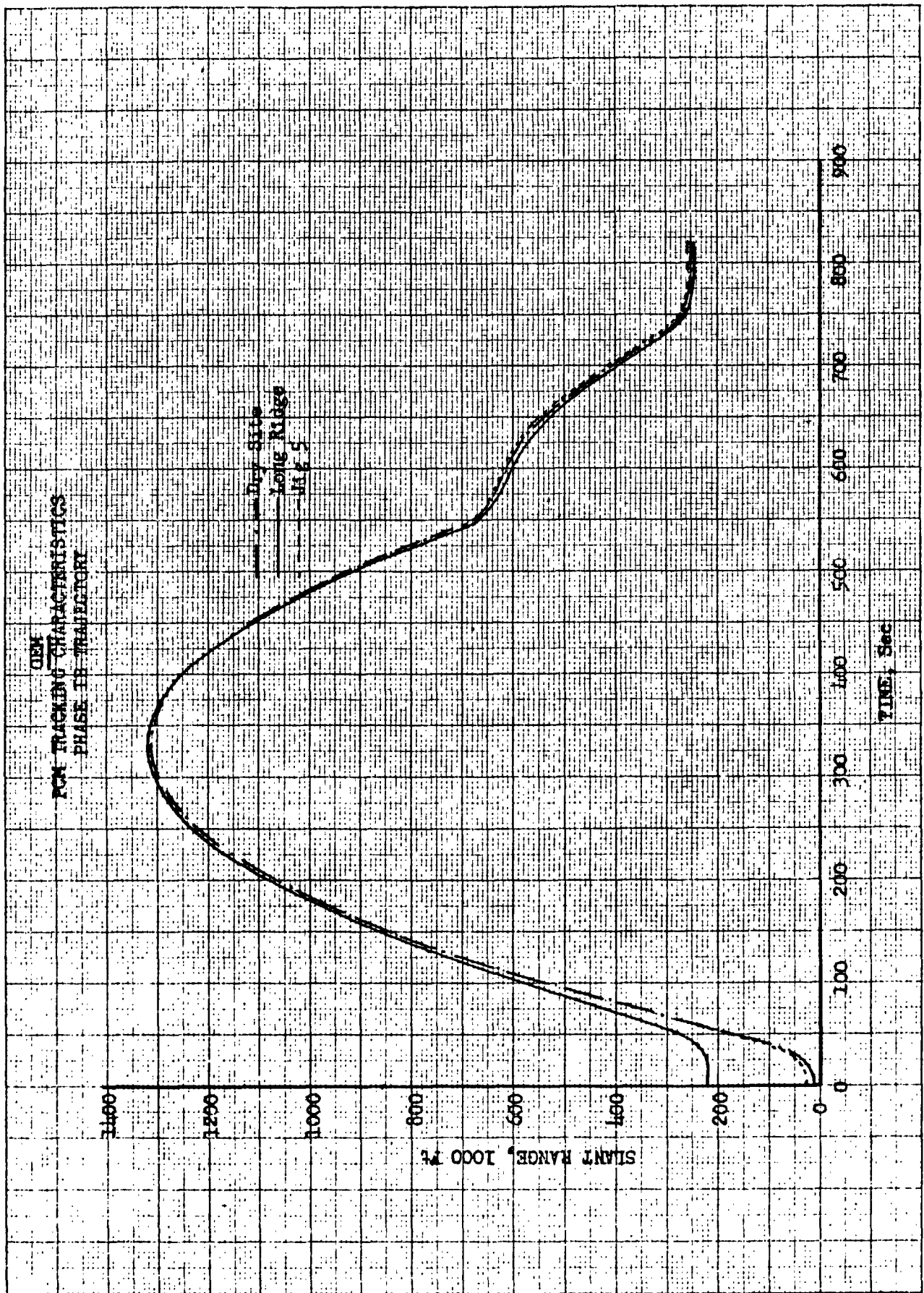

Figure 25

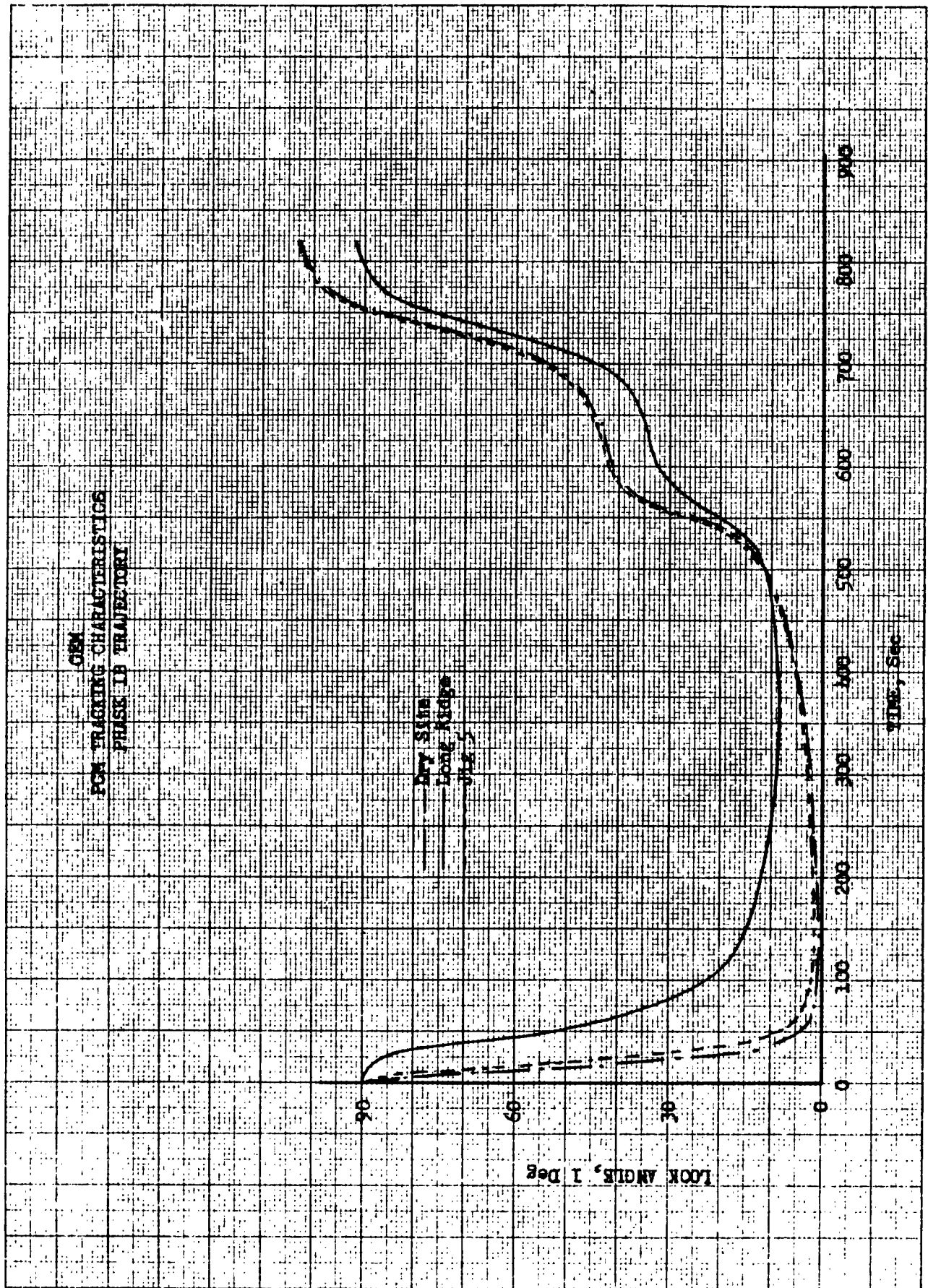

Figure 26
- 66 -

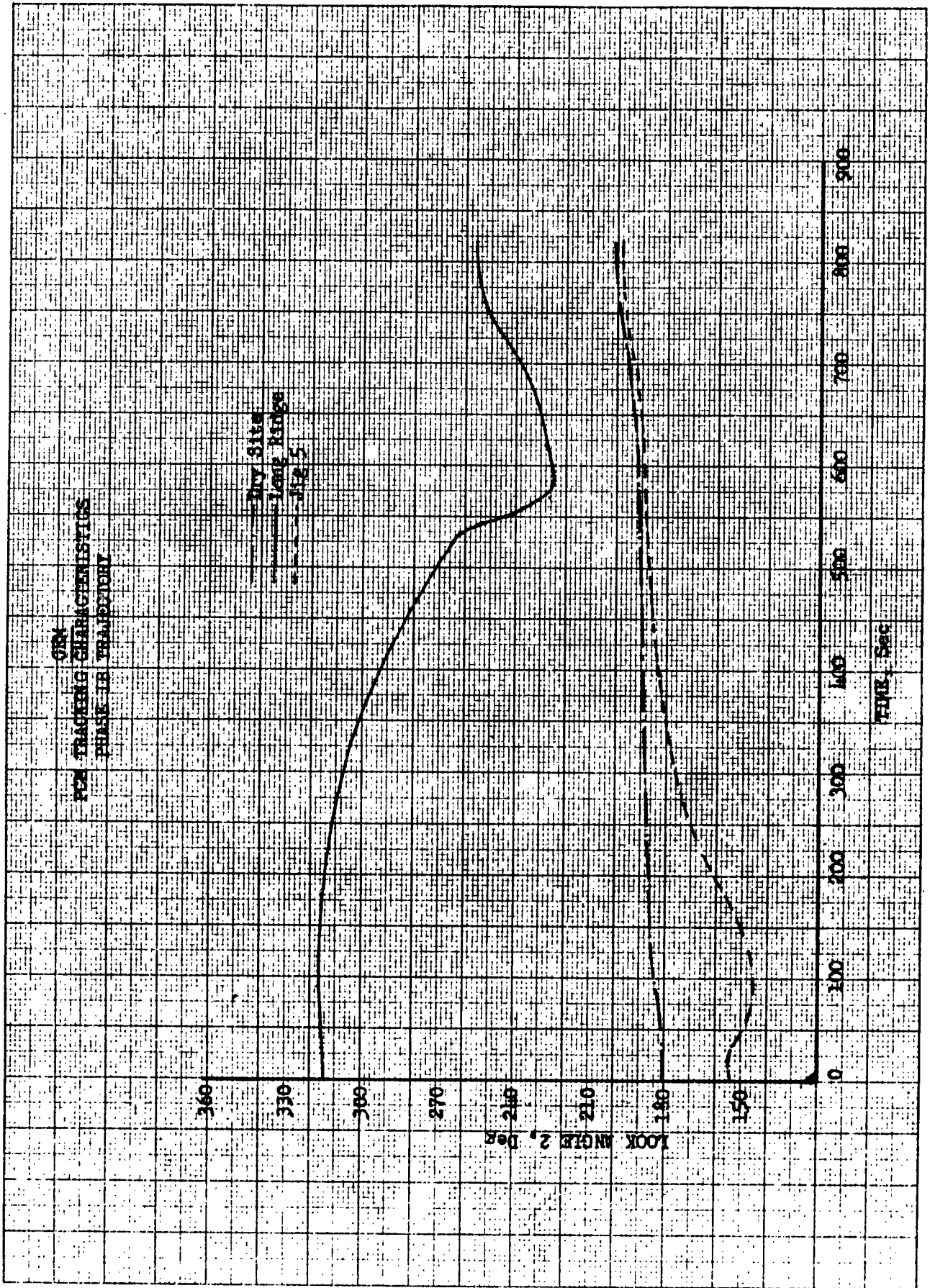

Figure 27

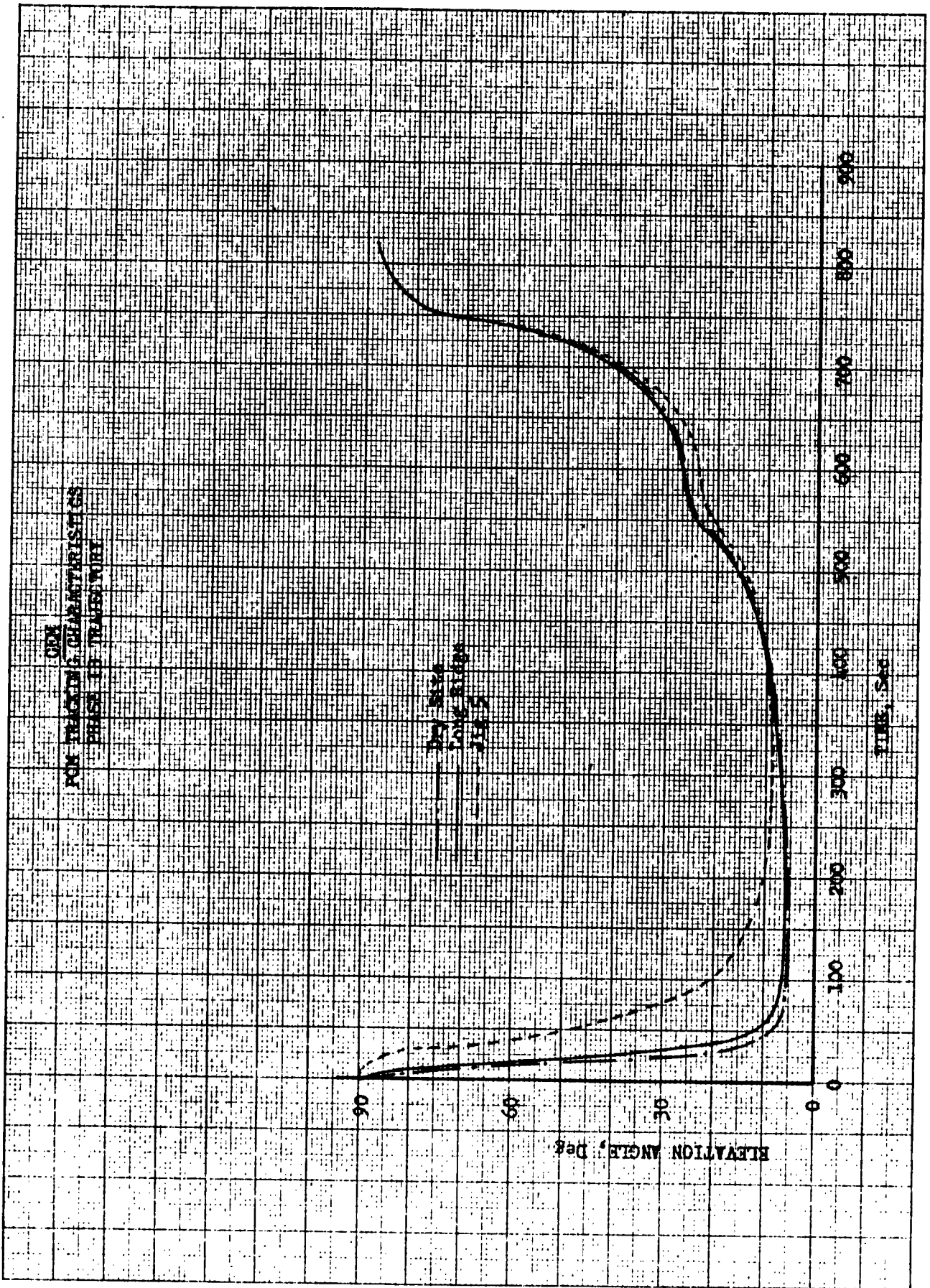

Figure 28

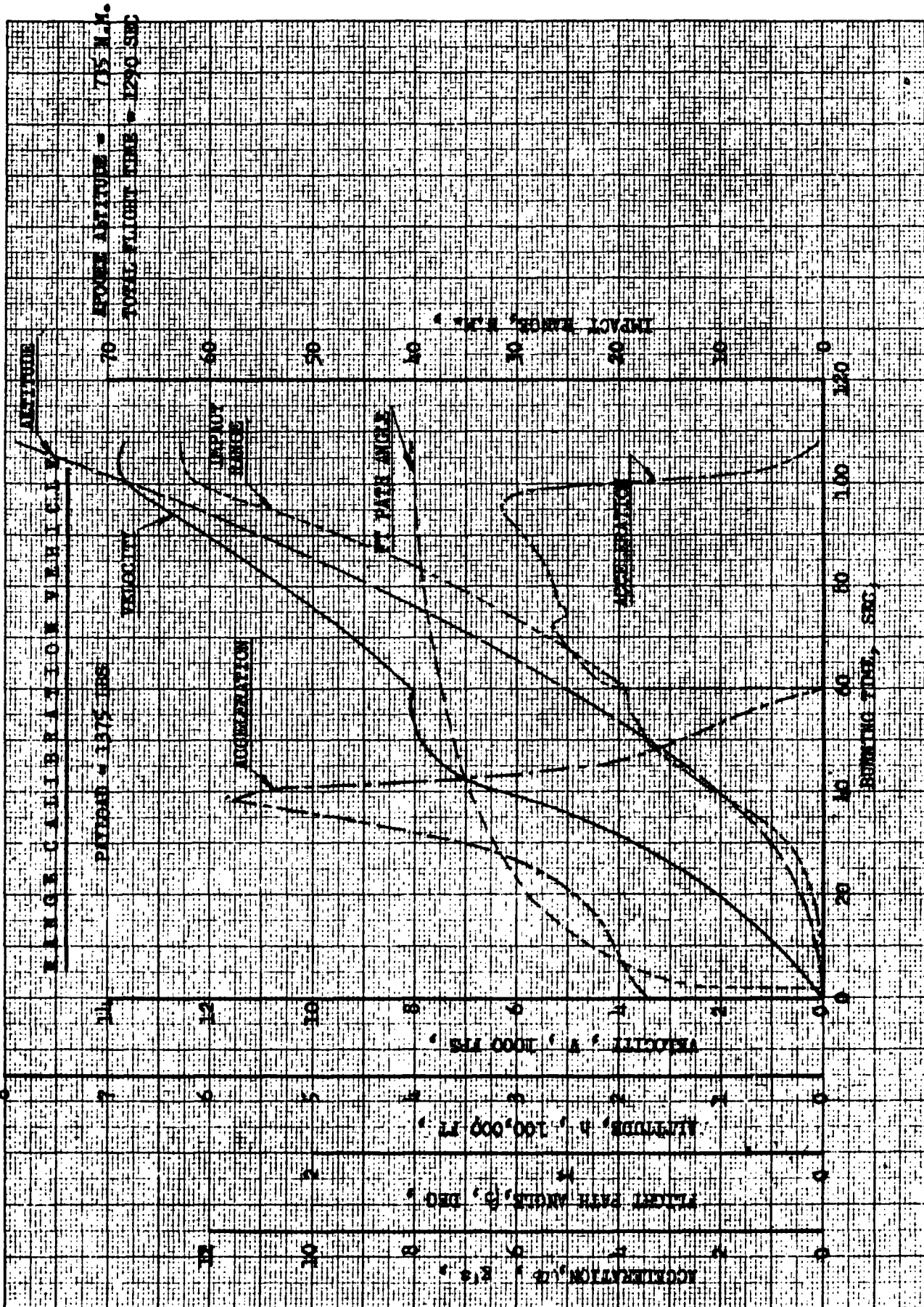

Figure 29

TABLE I
(Ascent)

TIME (sec)	ALTITUDE (ft)	VELOCITY (fps)	TEMP ₁ (°F)	TEMP ₂ (°F)	TEMP ₃ (°F)	DYNAMIC PRESSURE (psf)
0	4,000	0	60	60	60	0
5			71	60	60	
10	8,462	889	101	60	60	727
15			225	60	60	
20	21,880	1,830	403	62	60	1,991
25			744	67	60	
30	46,070	3,118	1,125	86	60	2,136
35			1,507	116	60	
40	86,740	5,263	1,813	175	61	859
45			1,635	248	65	
50	151,618	7,413	1,485	340	72	91.8
55			1,281	427	85	
60	226,805	7,530	1,037	474	105	6.20
65			920	517	132	
70	300,000	7,207				0

2. Re-entry Stagnation Point (Thermal Analyzer Program)

The re-entry stagnation point configuration is given below in Figure 2.

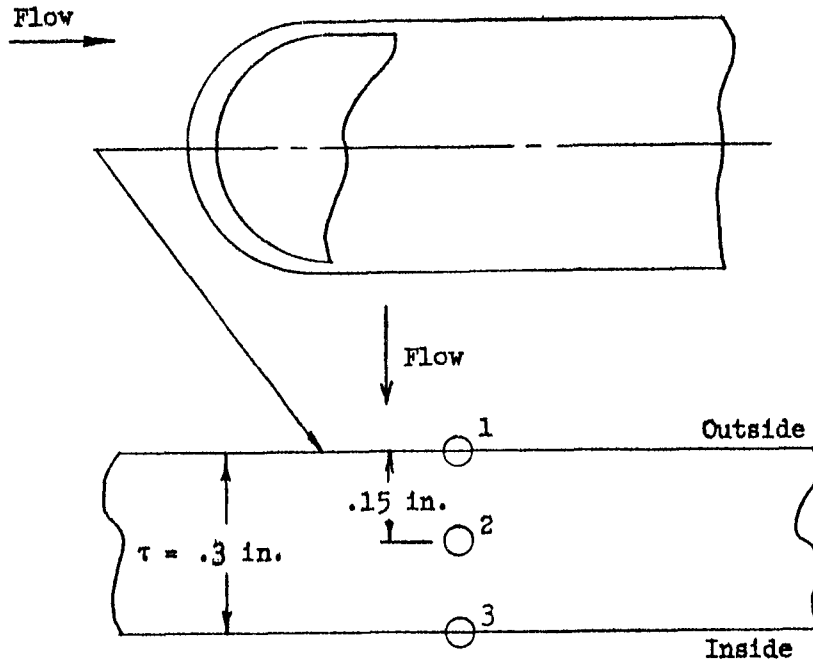

FIGURE 2

The material is fiberglass with the thermal properties as given in the ascent section.

Table II gives re-entry trajectory and temperature data.

The time spent in space (300,000 ft to 300,000 ft) is 485 sec. The cooling of the re-entry nose cap due to radiation during this time is accounted for in the temperature calculation.

TABLE II
(Re-entry)

TIME (sec)	ALTITUDE (ft)	VELOCITY (fps)	TEMP ₁ (°F)	TEMP ₂ (°F)	TEMP ₃ (°F)	DYNAMIC PRESSURE (psf)
0	300,000	7,207	39	43	45	.1
5	263,600	7,362	112	43	45	1.0
10	226,300	7,513	251	43	45	6.3
15	188,500	7,644	517	45	45	26.6
20	150,000	7,697	999	55	45	105
25	112,100	7,383	1,786	77	45	496
30	78,600	5,687	1,866	122	45	1,506
31.5	70,600	4,856				1,600
35	57,000	2,999	997	206	46	1,171
40	46,600	1,335	716	330	51	391
45	41,800	781	655	391	61	165
50	38,200	655	576	379	80	139
60	32,300	536	489	373	137	116
70	27,300	470	433	359	186	108
80	22,800	427	394	347	223	105
90	18,300	391	366	337	249	103
100	14,900	369	345	329	268	102
110	11,300	347	329	323	281	101
120	7,900	328	318	319	290	100
130	4,750	312	309	315	296	100
140	1,750	297	302	312	300	99
146	0	290	299	310	302	99

3. Ascent Payload Shell ("Thin Skin" Program)

The ascent payload shell configuration is given below in Figure 3

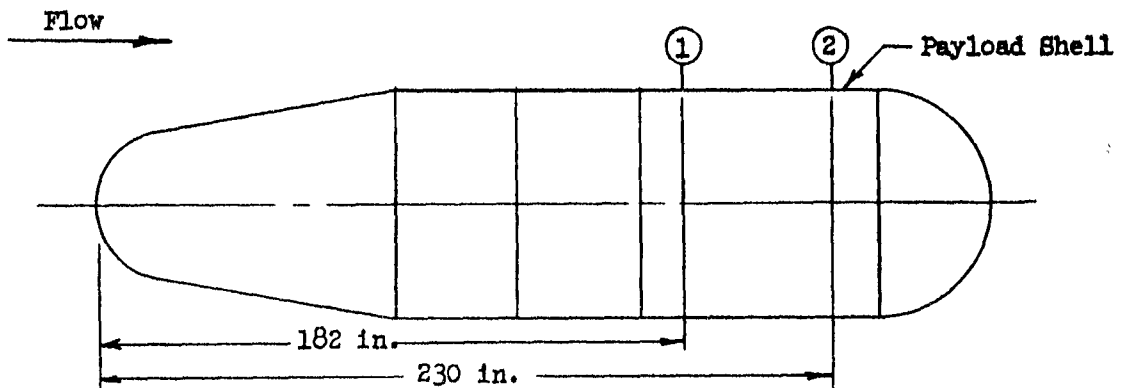

FIGURE 3

The material at stations ① and ② is 2014 T6 aluminum which has the following thermal properties.

$$\text{Density} = 175 \text{ lb/ft}^3$$

$$\text{specific heat} = .23 \text{ BTU/lb-}^\circ\text{F}$$

$$\text{thermal conductivity} = 89.6 \text{ BTU/ft-hr-}^\circ\text{F}$$

Four runs were made with the following combination of parameters.

Run	Station	Emissivity	Thickness	Initial Temperature
1	②	0.05	0.090 in.	60°F
2	②	0.20	0.090 in.	60°F
3	①	0.05	0.090 in.	60°F
4	②	0.05	0.180 in.	60°F

The results of these runs are given in Table III.

TABLE III
(Ascent)

TIME (sec)	ALTITUDE (ft)	VELOCITY (fps)	TEMP _{Run 1} (°R)	TEMP _{Run 2} (°R)	TEMP _{Run 3} (°R)	TEMP _{Run 4} (°R)	DYNAMIC PRESSURE (psf)
0	4,000	0	520	520	520	520	0
4	5,785	356	519	519	519	520	126
8	7,570	711	519	519	519	520	479
12	11,146	1,077	524	524	524	522	982
16	16,513	1,454	536	535	536	528	1,504
20	21,880	1,830	556	556	558	540	1,990
24	31,556	2,345	587	587	589	558	2,312
28	41,232	2,860	627	626	631	581	2,265
32	54,204	3,547	674	673	679	609	1,873
36	70,472	4,405	724	723	731	638	1,328
40	86,740	5,263	769	768	777	663	859
44	112,691	6,123	800	799	810	682	331
48	138,642	6,983	819	817	829	692	138
52	166,655	7,436	830	828	840	698	52.9
56	196,730	7,483	833	831	845	700	19.2
60	226,805	7,530	834	831	847	701	6.2
64	256,083	7,401	835	831	848	701	1.6
68	285,361	7,272	835	831	848	701	.3
70	300,000	7,207	835	831	848	701	.1

4. Re-entry Payload Shell ("Thin Skin" Program)

The re-entry payload shell configuration is given below in Figure 4.

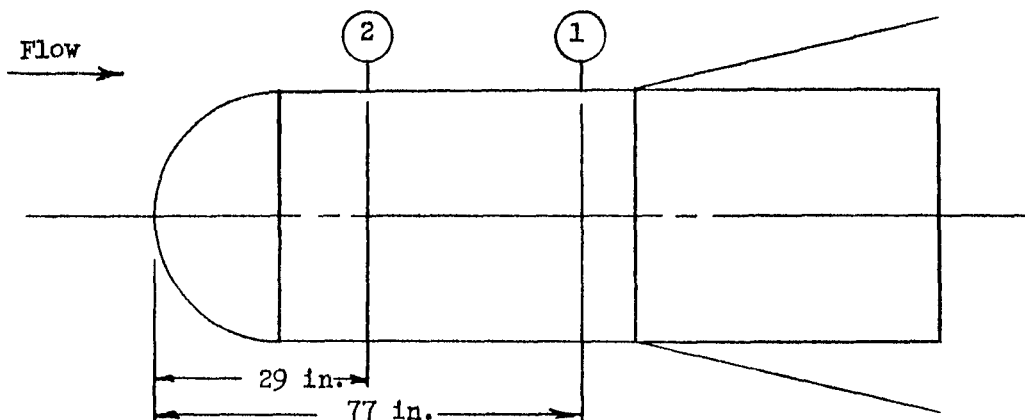

FIGURE 4

Note that stations ① and ② are the same stations discussed in the ascent payload shell section.

Again four runs were made with the following combinations of parameters.

Run	Station	Emissivity	Thickness	Initial Temperature
1	②	0.05	0.090 in.	500°F
2	①	0.05	0.090 in.	500°F
3	②	0.05	0.090 in.	200°F
4	①	0.05	0.090 in.	200°F

The results of these runs are given in Table IV.

TABLE IV
(Re-entry)

TIME (sec)	ALTITUDE (ft)	VELOCITY (fps)	TEMP Run 1 (°R)	TEMP Run 2 (°R)	TEMP Run 3 (°R)	TEMP Run 4 (°R)	DYNAMIC PRESSURE (psf)
0	300,000	7,207	960	960	660	660	.1
4	270,861	7,331	960	960	660	660	.7
8	241,260	7,453	961	960	661	661	3.2
12	211,219	7,565	962	961	663	662	11.6
16	180,792	7,655	965	963	666	665	34.4
20	150,064	7,697	970	967	673	670	105
24	119,670	7,446	989	985	697	698	357
28	91,317	6,526	1,043	1,036	768	758	1,048
32	68,288	4,573	1,106	1,090	854	834	1,588
36	54,235	2,561	1,118	1,101	886	862	975
40	46,728	1,235	1,091	1,079	871	851	325
44	43,325	1,004	1,060	1,052	848	832	252
48	39,922	773	1,030	1,027	825	813	176
52	37,086	636	1,002	1,003	803	795	137
56	34,819	593	974	979	782	777	131
60	32,551	550	947	955	761	759	123
64	30,283	507	920	932	741	742	113
68	28,409	487	893	909	722	726	112
72	26,591	469	867	886	704	710	111
76	24,773	452	842	864	686	694	110
80	22,955	434	817	842	668	679	108
84	21,136	417	793	820	653	665	106
88	19,439	402	770	799	638	651	104
92	17,944	391	748	779	624	638	104
96	16,448	380	727	760	611	626	103
100	14,953	369	708	741	599	615	102
104	13,653	362	688	723	588	604	102
108	12,352	355	671	706	578	595	103
112	11,052	348	655	690	569	586	103
116	9,752	341	640	675	562	578	103
120	8,452	335	627	661	555	571	103
124	7,151	328	614	648	549	565	103
128	5,851	321	603	636	544	559	103
132	4,551	314	593	625	540	555	102
136	3,251	307	585	615	537	551	102
146	0	290	568	594	533	544	100

5. Ascent and Re-entry Payload Shell (Thermal Analyzer Program)

This run is a repeat of station ② (see Figures 3 and 4) with 0.1 in. of Avcoat on the aluminum skin. The thermal model is shown below in Figure 5.

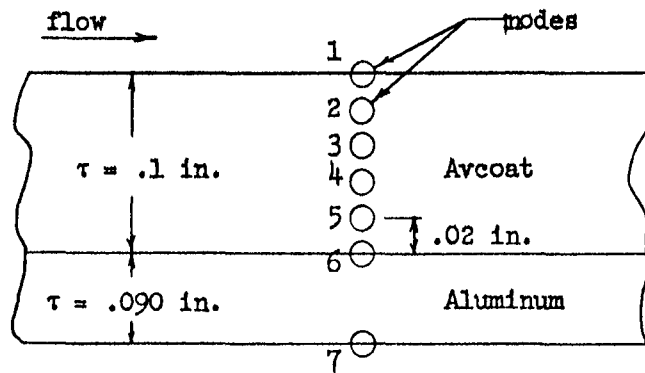

FIGURE 5

Avcoat has the following thermal properties.

$$\text{density} = 71 \text{ lb/ft}^3$$

$$\text{specific heat} = .44 \text{ BTU/lb-}^\circ\text{F}$$

$$\text{thermal conductivity} = .13 \text{ BTU/ft-hr-}^\circ\text{F}$$

The results of this run are given in Tables V (a) and (b). The effect of cooling in space (485 sec) is included in the calculations.

TABLE V (a)
(Ascent)

TIME (sec)	TEMP ₁ (°F)	TEMP ₂ (°F)	TEMP ₃ (°F)	TEMP ₄ (°F)	TEMP ₅ (°F)	TEMP ₆ (°F)	TEMP ₇ (°F)
0	60	60	60	60	60	60	60
5	54	56	58	59	60	60	60
10	79	64	60	59	59	60	60
15	151	101	77	66	62	60	60
20	274	174	117	87	71	62	62
25	428	278	183	125	90	67	66
30	572	393	266	179	120	77	76
35	664	486	344	237	156	93	93
40	664	530	400	286	192	115	114
45	570	502	410	313	221	139	139
50	479	447	388	314	236	163	163
55	393	388	354	302	242	183	183
60	334	336	317	284	242	199	199
65	299	301	290	268	240	210	210
70	275	277	271	256	237	217	217

TABLE V (b)
(Re-entry)

Entry Velocity = 7207 fps
Entry Altitude = 300,000 ft

TIME (sec)	TEMP ₁ (°F)	TEMP ₂ (°F)	TEMP ₃ (°F)	TEMP ₄ (°F)	TEMP ₅ (°F)	TEMP ₆ (°F)	TEMP ₇ (°F)
0	186	188	190	192	193	194	194
5	189	189	190	191	193	194	194
10	196	192	191	192	193	193	193
15	212	205	196	194	193	193	193
20	243	219	205	199	195	194	194
25	516	338	256	219	203	195	195
30	818	562	391	290	234	201	200
35	769	647	501	377	285	217	216
40	532	541	486	404	318	240	240
45	427	444	426	381	322	262	261
50	361	382	378	353	317	277	277
60	286	307	315	313	304	292	292
70	249	269	282	290	293	294	294
80	230	249	264	276	285	292	292
90	222	239	253	266	277	286	287
100	219	233	247	260	271	281	281
110	219	231	243	254	265	275	275
120	223	232	242	252	261	269	269
130	231	236	243	251	258	265	265
140	239	242	246	251	256	261	261
145	244	245	248	252	256	260	260

6. Ascent Nose Cap (2D Trajectory Heating Program)

The geometry of the ascent nose cap is shown below in Figure 6.

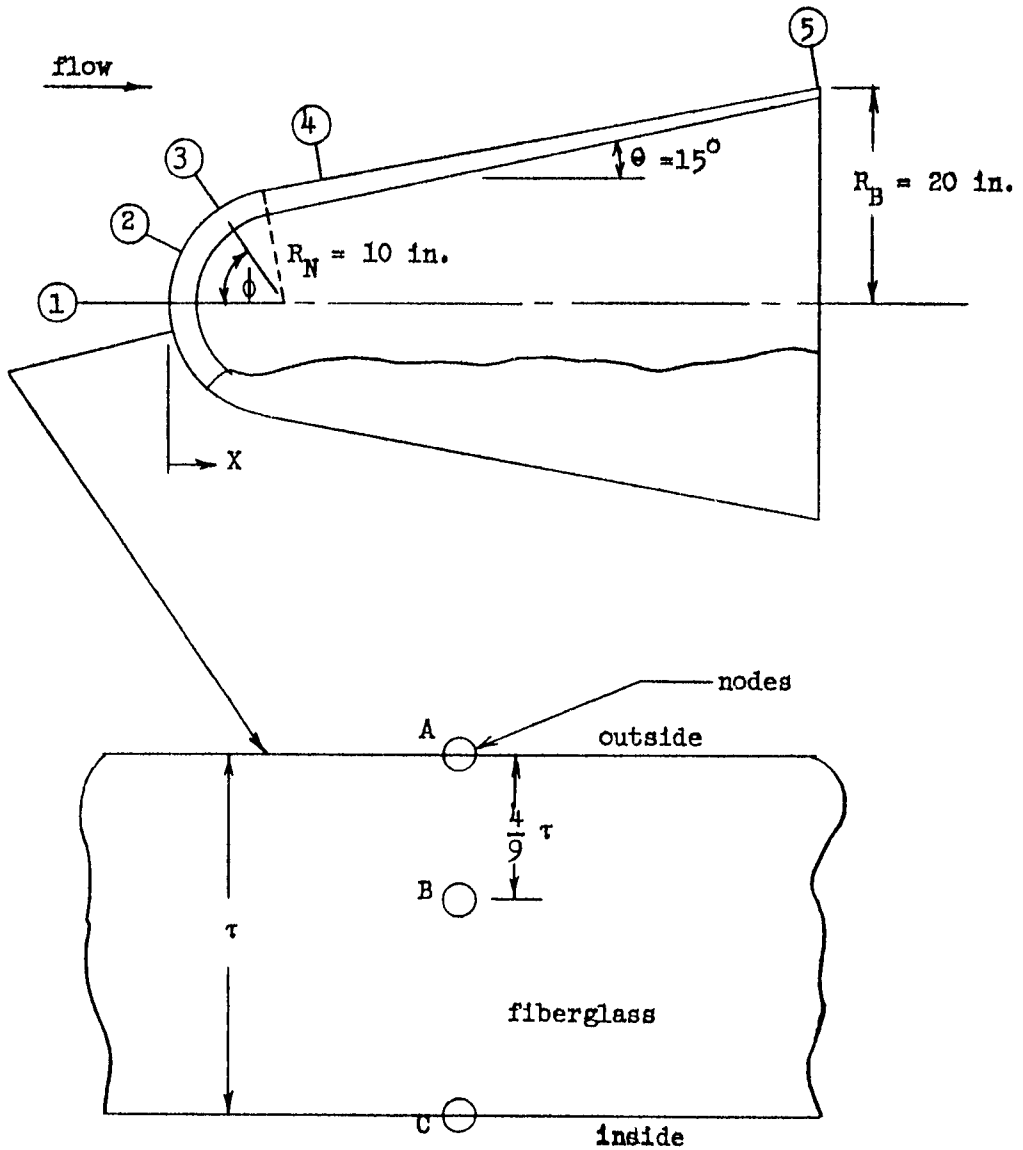

FIGURE 6

Table VI (a) gives the location of the points of interest. The material is fiberglass with the thermal properties given in Section 1. Temperature distributions are given in Tables VI (b) and (c). The difference between Point ① of the present data and the same point (stagnation point) of Section 1 (Ascent Stagnation Point) is that the present calculations include the effect of wall temperature on heating rate whereas the heating rate used in Section 1 was for a cold wall (zero wall temperature).

TABLE VI (a)

POINT	ϕ (DEG)	X(IN.)	THICKNESS, τ (IN.)
1	0		0.300
2	28.11		0.300
3	56.22		0.300
4		12.93	0.279
5		46.01	0.150

TABLE VI (b)

TIME (sec)	POINT 1			POINT 2			POINT 3		
	TEMP _A (°R)	TEMP _B (°R)	TEMP _C (°R)	TEMP _A (°R)	TEMP _B (°R)	TEMP _C (°R)	TEMP _A (°R)	TEMP _B (°R)	TEMP _C (°R)
0	520	520	520	520	520	520	520	520	520
5	515	520	520	515	520	520	515	520	520
10	529	520	520	540	520	520	529	520	520
15	562	520	520	590	520	520	563	520	520
20	621	522	520	676	524	520	625	522	520
25	726	527	520	824	532	520	733	527	520
30	882	538	520	1029	548	521	883	539	520
35	1141	558	521	1122	574	522	1000	558	521
40	1426	590	523	1355	608	525	1078	589	523
45	1592	639	526	1494	651	529	1114	621	527
50	1660	698	533	1548	702	537	1122	652	533
55	1561	758	543	1461	754	549	1072	681	541
60	1422	810	559	1339	798	564	1005	703	552
65	1289	847	578	1222	829	583	943	719	565
70	1183	868	601	1129	848	604	893	728	579

TABLE VI (c)

TIME (sec)	POINT 4			POINT 5		
	TEMP _A (°R)	TEMP _B (°R)	TEMP _C (°R)	TEMP _A (°R)	TEMP _B (°R)	TEMP _C (°R)
0	520	520	520	520	520	520
5	516	520	520	516	520	520
10	524	520	520	525	520	520
15	543	520	520	546	522	520
20	584	521	520	590	530	521
25	655	525	520	666	549	525
30	753	534	520	770	581	535
35	884	550	521	904	629	554
40	857	572	523	937	692	584
45	858	595	527	881	727	625
50	854	613	532	863	743	663
55	824	628	540	834	754	693
60	789	640	549	806	760	716
65	756	647	558	784	760	732
70	730	650	568	768	759	743

7. Re-entry Nose Cap (2D Trajectory Heating Program)

The geometry of the re-entry nose cap is shown below in Figure 7.

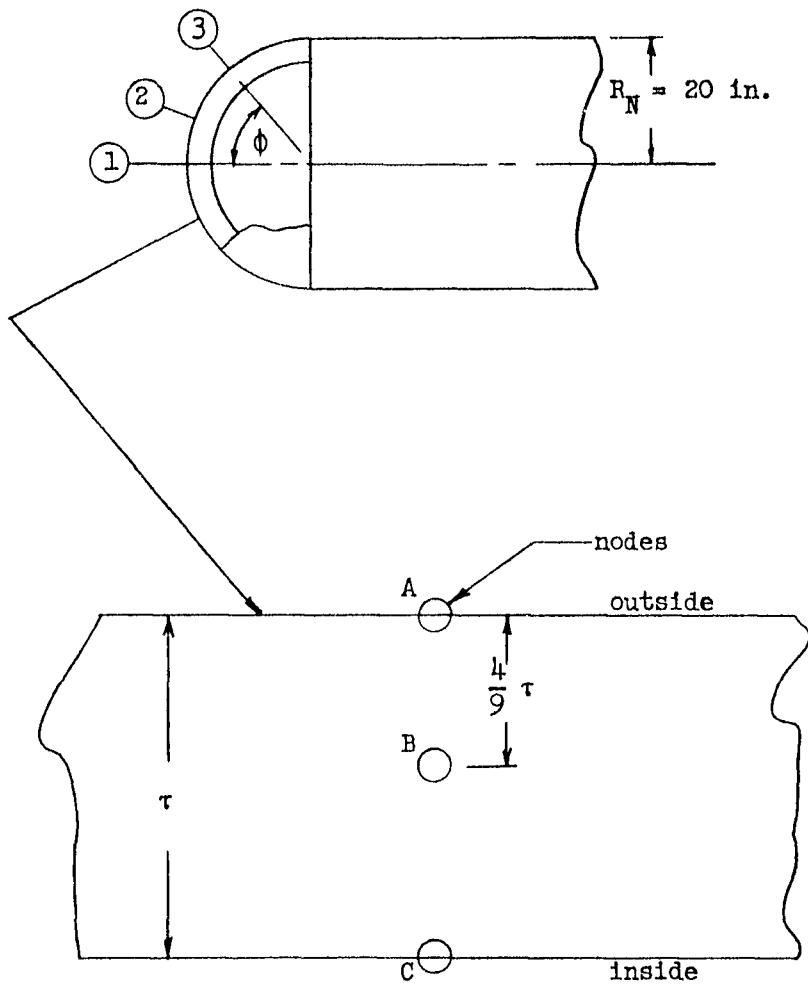

FIGURE 7

Table VII (a) gives the location of the points of interest. The material is fiberglass with the thermal properties given in Section 1. Temperature distributions are given in Table VII (b) Again the stagnation point temperatures (Point ①) of this section differ from those of Section 2. (Re-entry Stagnation Point) by the inclusion of wall temperature effects on heating rates in the present calculations.

TABLE VII (a)

POINT	ϕ (DEG)	THICKNESS, τ (IN.)
①	0	0.4
②	38.58	0.4
③	64.30	0.4

Entry Velocity = 7207 fps
 Entry Altitude = 300,000 ft

TABLE VII (b)

TIME (sec)	POINT 1			POINT 2			POINT 3		
	TEMP _A (°R)	TEMP _B (°R)	TEMP _C (°R)	TEMP _A (°R)	TEMP _B (°R)	TEMP _C (°R)	TEMP _A (°R)	TEMP _B (°R)	TEMP _C (°R)
0	505	505	505	505	505	505	505	505	505
5	542	505	505	531	505	505	516	505	505
10	621	505	505	589	505	505	541	505	505
15	783	507	505	708	507	505	594	506	505
20	1070	512	505	924	510	505	694	507	505
25	1518	523	505	1286	518	505	879	511	505
30	1739	545	505	1526	535	505	1268	519	505
35	1322	580	506	1270	562	506	1145	533	505
40	986	618	507	836	595	506	860	555	506
45	848	648	509	748	621	508	747	576	506
50	764	665	513	633	634	511	682	591	508
60	664	674	524	540	637	520	604	601	514
70	611	666	539	505	624	532	562	599	522
80	579	652	555	492	607	544	538	591	531
90	559	638	568	489	591	553	524	581	538
100	547	625	578	495	578	560	518	573	545
110	541	614	586	500	569	564	516	565	549
120	538	605	591	505	561	567	516	559	553
130	537	597	594	512	556	567	519	555	554
140	539	592	596	520	553	567	523	551	555
145	541	589	596	524	552	566	526	550	555

8. First Stage Motor Case, Retro Motor Case and Fairing ("Thin Skin" Program)

The 1st stage motor case, retro motor case, and fairing configuration is given below in Figure 8.

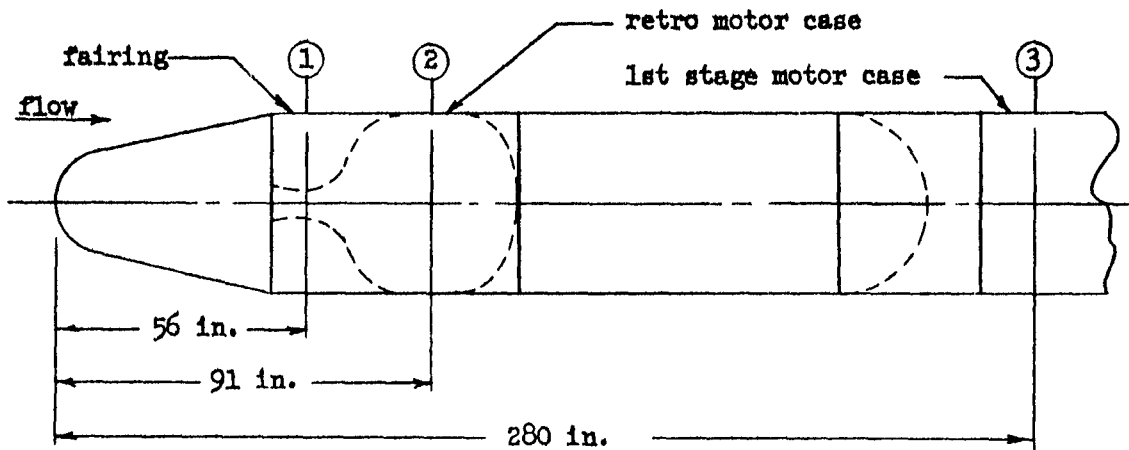

FIGURE 8

The fairing is 2014T6 aluminum with the properties given in Section 3 (Ascent Payload Shell). The motor cases are stainless steel with the following thermal properties.

$$\text{density} = 484 \text{ lb/ft}^3$$

$$\text{specific heat} = .11 \text{ BTU/lb-}^\circ\text{F}$$

$$\text{thermal conductivity} = 16.6 \text{ Btu/ft-hr-}^\circ\text{F}$$

Four runs were made for the ascent trajectory given in Section 3 with the following combination of parameters.

RUN	STATION	LOCAL PROPERTIES	EMISSIVITY	THICKNESS	INITIAL TEMPERATURE
1	①	NS to FS	0.050	0.090 in.	60 °F
2	②	NS to FS	0.10	0.068 in.	60 °F
3	②	FS	0.10	0.068 in.	60 °F
4	③	FS	0.10	0.125 in.	60 °F

The local property designations mean the following:

NS to FS: Normal shock to free stream. The local total pressure is that behind a normal shock at the free stream Mach No. at a given time. The static pressure is the free stream static pressure at the corresponding altitude.

FS: Free stream. Both the local total and static pressures are the free stream values at a given time. This is the most conservative method.

The results of these runs are given in Table VIII.

TABLE VIII

TIME (sec)	TEMP _{Run 1} (°R)	TEMP _{Run 2} (°R)	TEMP _{Run 3} (°R)	TEMP _{Run 4} (°R)
0	520	520	520	520
4	520	520	520	520
8	519	519	519	520
12	525	524	524	522
16	540	537	537	528
20	565	559	559	539
24	602	591	591	556
28	647	631	633	578
32	699	676	682	605
36	753	722	733	632
40	801	762	780	657
44	825	789	812	674
48	831	794	831	683
52	836	797	839	689
56	839	799	841	691
60	841	801	842	691
64	842	801	843	692
68	842	801	843	692
70	842	801	843	692

9. Flaps

The flap configuration is shown below in Figure 9(a).

Ascent

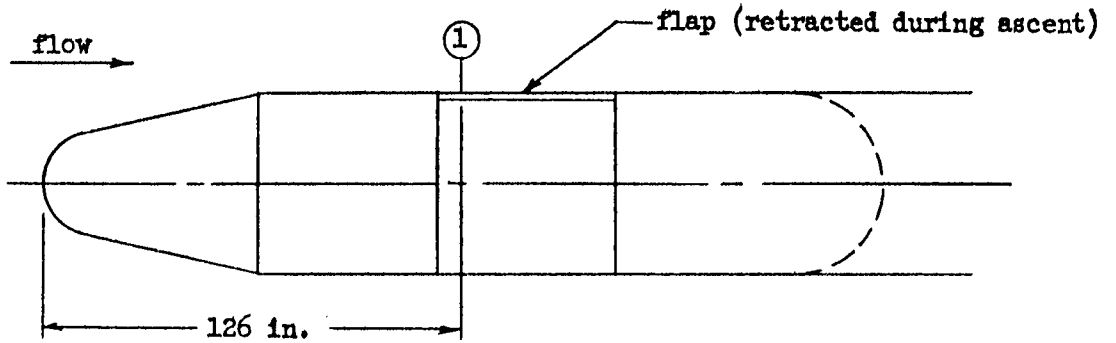

Re-entry

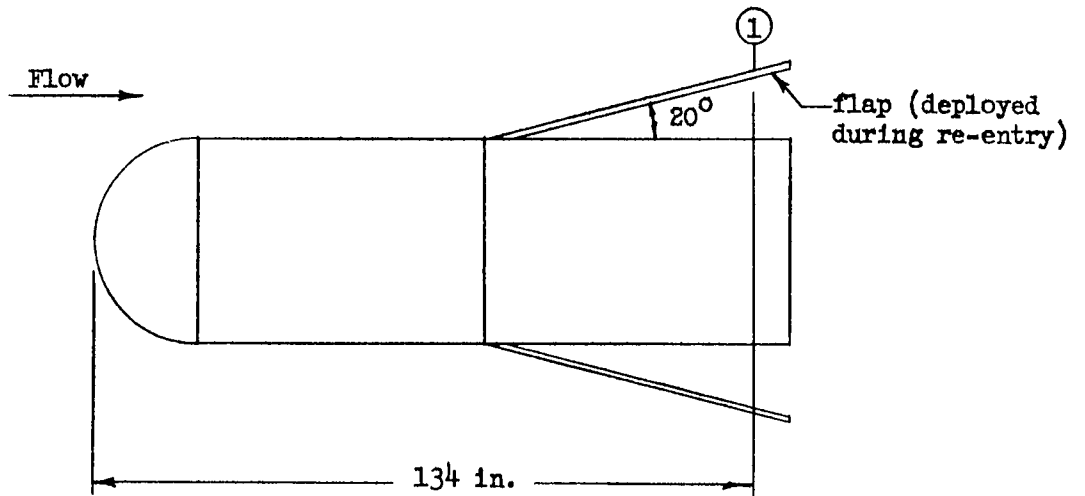

FIGURE 9(a)

The flap itself is a fiberglass hex-cell honeycomb as shown below in Figure 9(b).

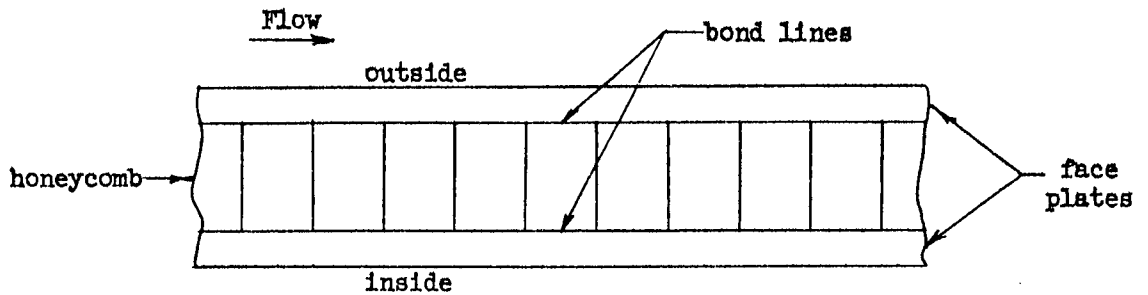

FIGURE 9(b)

The properties of fiberglass are given in Section 1. It was found that machine runs of the complete honeycomb structure consumed an intolerable amount of machine time, hence, the outside face plate was run alone assuming no heat flux passed to the honeycomb. This procedure gives conservative temperatures on the face plate. The critical temperature is the bond line temperature which is assumed to be 900^oF.

Three runs were made assuming solid fiberglass face plates. A fourth run was made with Avcoat bonded to the fiberglass (see Figure 9(c) below). The properties of Avcoat are given in Section 5.

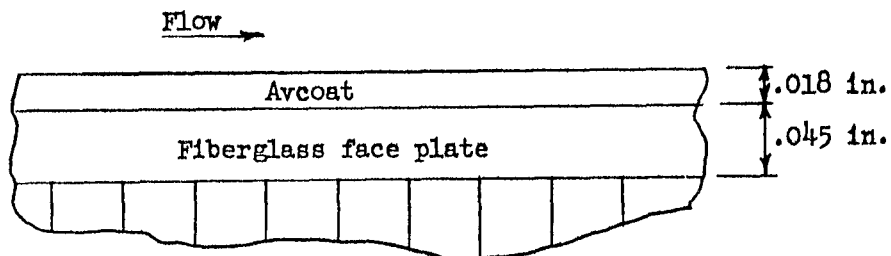

FIGURE 9(c)

The four runs were made at station (1) assuming the following conditions.

RUN	MATERIAL	EMISSIVITY	THICKNESS	INITIAL TEMPERATURE
1	fiberglass	0.8	0.027 in.	60 °F
2	fiberglass	0.8	0.045 in.	60 °F
3	fiberglass	0.8	0.063 in.	60 °F
4	Avcoat on fiberglass	0.5	Avcoat = .018 in. fiberglass = .045 in.	60 °F

The node designations for the four runs are given below in Figure 9(d).

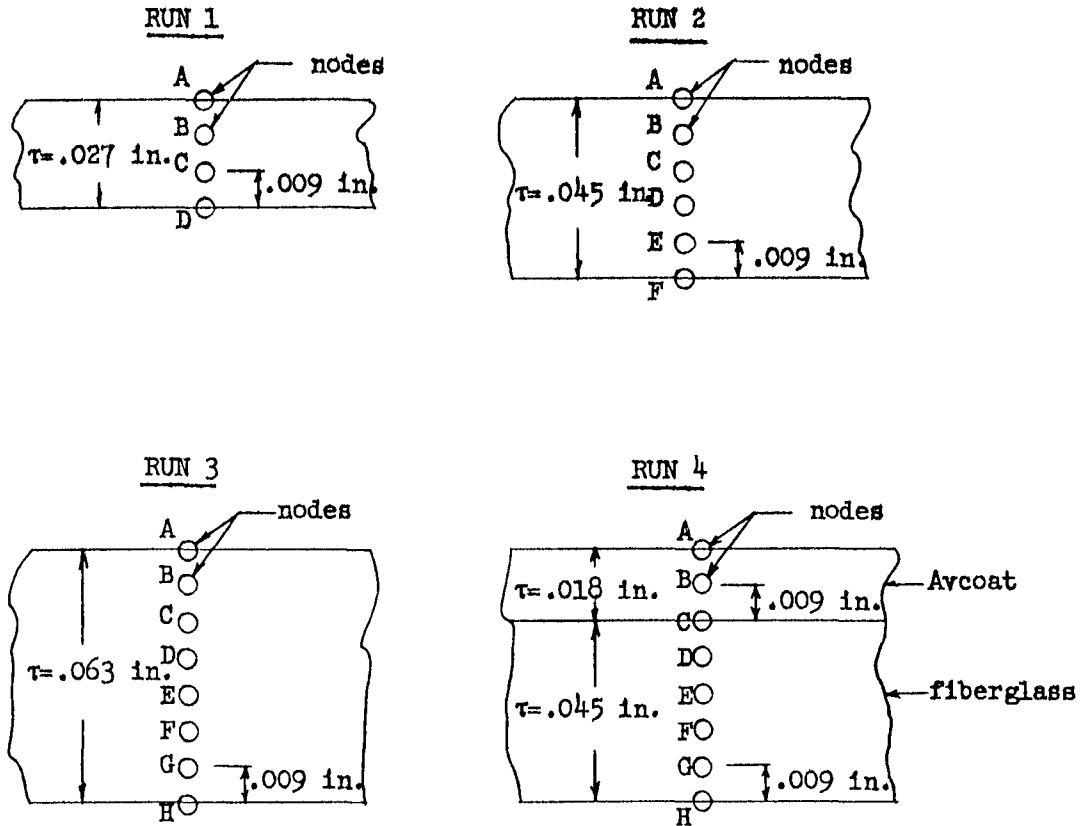

FIGURE 9(d)

The effect of cooling in space has been accounted for in these calculations. The results of these runs are given in Tables IX (a), (b), (c), (d), (e), (f), (g) and (h).

TABLE IX (a)
(Run 1 - Ascent)

TIME (sec)	TEMP _A (°F)	TEMP _B (°F)	TEMP _C (°F)	TEMP _D (°F)
0	60	60	60	60
5	52	53	54	54
10	64	60	57	56
15	132	116	106	101
20	283	251	231	221
25	529	481	449	434
30	826	772	736	718
35	1082	1041	1012	998
40	1212	1194	1181	1175
45	1190	1198	1203	1206
50	1100	1119	1131	1137
55	980	1000	1013	1020
60	887	903	914	919
65	818	830	838	842
70	754	765	773	777

TABLE IX (b)
(Run 1 - Re-entry)

Entry Velocity = 7207 fps
Entry Altitude = 300,000 ft

TIME (sec)	TEMP _A (°F)	TEMP _B (°F)	TEMP _C (°F)	TEMP _D (°F)
0	27	27	27	27
5	27	27	27	27
10	32	31	30	30
15	37	44	42	41
20	82	75	70	67
25	517	417	353	322
30	1193	1089	1017	979
35	1363	1359	1353	1349
40	1177	1214	1237	1248
45	1012	1040	1059	1069
50	885	907	922	929
60	698	713	722	727
70	566	577	584	588
80	466	474	479	482
90	386	393	397	400
100	323	328	332	333
110	272	276	279	280
120	232	235	238	239
130	202	205	207	208
140	183	185	186	186
145	176	178	178	179

TABLE IX (c)
(Run 2 - Ascent)

TIME (sec)	TEMP _A (°F)	TEMP _B (°F)	TEMP _C (°F)	TEMP _D (°F)	TEMP _E (°F)	TEMP _F (°F)
0	60	60	60	60	60	60
5	53	55	56	57	57	57
10	66	62	60	58	57	57
15	121	105	94	86	81	78
20	233	201	176	159	148	142
25	408	358	319	290	272	263
30	619	558	510	474	450	438
35	814	757	710	675	652	640
40	936	897	865	839	822	814
45	949	939	930	922	917	914
50	917	924	929	931	932	933
55	860	873	884	892	898	900
60	817	830	841	849	854	856
65	758	796	804	810	815	817
70	748	759	767	774	779	781

TABLE IX (d)
(Run 2 - Re-entry)

Entry Velocity = 7207 fps
Entry Altitude = 300,000 ft

TIME (Sec)	TEMP _A (°F)	TEMP _B (°F)	TEMP _C (°F)	TEMP _D (°F)	TEMP _E (°F)	TEMP _F (°F)
0	111	111	112	112	112	112
5	110	110	111	111	111	111
10	114	113	112	112	111	111
15	125	122	119	118	117	116
20	149	142	137	133	131	129
25	516	415	342	290	257	242
30	995	876	777	700	648	622
35	1085	1053	1020	991	969	957
40	961	981	995	1003	1008	1010
45	886	906	923	935	944	948
50	823	842	858	869	877	881
60	718	733	746	755	761	764
70	634	646	656	663	669	671
80	564	574	582	589	593	595
90	506	515	522	527	530	532
100	458	465	471	475	478	480
110	419	424	429	433	435	436
120	386	391	395	398	400	401
130	361	365	368	370	371	372
140	342	345	347	349	350	350
145	334	337	339	340	341	342

TABLE IX (e)
(Run 3 - Ascent)

TIME (sec)	TEMP _A (°F)	TEMP _B (°F)	TEMP _C (°F)	TEMP _D (°F)	TEMP _E (°F)	TEMP _F (°F)	TEMP _G (°F)	TEMP _H (°F)
0	60	60	60	60	60	60	60	60
5	54	55	56	57	57	58	59	59
10	68	63	61	59	58	58	57	57
15	119	104	92	83	76	72	69	68
20	219	187	161	142	126	116	109	105
25	369	318	277	244	218	200	187	181
30	542	479	426	383	349	324	308	299
35	695	634	581	536	500	472	454	445
40	784	738	697	661	632	610	594	587
45	780	762	745	728	713	702	693	689
50	751	751	748	745	741	737	735	734
55	708	716	722	727	731	733	735	736
60	687	695	702	708	712	716	718	719
65	674	681	687	691	695	698	700	701
70	653	661	668	673	678	681	683	684

TABLE IX (f)

Entry Velocity = 7207 fps
Entry Altitude = 300,000 ft

(Run 3 - Re-entry)

TIME (sec)	TEMP _A (°F)	TEMP _B (°F)	TEMP _C (°F)	TEMP _D (°F)	TEMP _E (°F)	TEMP _F (°F)	TEMP _G (°F)	TEMP _H (°F)
0	163	164	165	165	166	166	166	166
5	163	163	164	164	164	164	164	164
10	166	165	165	164	164	164	164	164
15	176	173	170	169	167	157	166	166
20	197	190	185	180	177	175	174	173
25	549	449	373	317	277	249	232	224
30	958	836	729	638	564	508	471	453
35	965	926	880	835	794	760	737	724
40	811	824	830	832	831	829	827	826
45	754	769	781	791	799	805	809	811
50	717	732	745	755	764	770	775	777
60	654	667	677	688	696	702	706	708
70	601	612	622	631	637	642	646	648
80	554	564	573	580	586	591	594	595
90	514	523	531	537	542	546	548	550
100	480	488	494	499	504	507	509	510
110	451	457	463	467	471	474	476	477
120	427	432	437	441	444	446	448	448
130	407	412	415	418	421	423	424	425
140	392	396	398	401	403	404	405	406
145	386	389	392	394	395	397	398	398

TABLE IX (g)

(Run 4 - Ascent)

TIME (sec)	TEMP _A (°F)	TEMP _B (°F)	TEMP _C (°F)	TEMP _D (°F)	TEMP _E (°F)	TEMP _F (°F)	TEMP _G (°F)	TEMP _H (°F)
0	60	60	60	60	60	60	60	60
5	53	54	56	57	58	58	59	59
10	70	64	60	59	58	58	57	57
15	131	107	90	81	75	71	68	67
20	244	195	157	138	123	113	106	103
25	408	331	269	237	212	194	182	176
30	588	493	413	372	339	314	298	290
35	735	643	563	519	484	458	440	431
40	808	739	677	642	613	591	577	569
45	781	754	726	709	694	683	674	670
50	738	737	732	728	723	720	717	716
55	689	700	708	712	716	718	719	720
60	668	680	690	695	699	702	704	705
65	658	667	675	680	683	686	688	689
70	636	648	658	663	667	670	672	673

TABLE IX (h)
(Run 4 - Re-entry)

Entry Velocity = 7207 fps
Entry Altitude = 300,000 ft

TIME (sec)	TEMP _A (°F)	TEMP _B (°F)	TEMP _C (°F)	TEMP _D (°F)	TEMP _E (°F)	TEMP _F (°F)	TEMP _G (°F)	TEMP _H (°F)
0	165	166	167	168	168	168	169	169
5	165	165	166	166	167	167	167	167
10	169	168	167	167	166	166	166	166
15	180	176	172	171	170	169	168	168
20	205	194	186	182	179	177	176	175
25	623	472	361	309	271	245	229	222
30	1037	858	699	612	542	489	454	437
35	981	922	851	806	765	732	709	697
40	785	803	809	809	807	804	802	800
45	725	746	763	773	780	785	788	790
50	689	711	729	739	747	753	757	759
60	631	650	667	676	684	689	693	695
70	582	599	614	622	628	633	636	638
80	539	554	566	573	579	583	586	588
90	502	514	526	532	537	540	543	544
100	470	481	490	496	500	503	505	506
110	442	452	460	465	468	471	473	474
120	420	428	435	438	441	444	445	446
130	402	408	414	417	419	421	422	423
140	388	393	397	400	402	403	404	405
145	382	387	391	393	394	396	397	397

APPENDIX 4

AERODYNAMIC COMPUTATIONS

A. Force Coefficients and Centers of Pressure

Aerodynamic coefficients for the GEM ascent and descent vehicles were computed in order to obtain performance and trajectory data for the respective vehicles. Since NASA data were available for the Scout vehicle, these experimental data of References 3, 4, and 5 were used in the computations of axial force coefficient C_A , normal force derivative, $dC_N/d\alpha$, and the center of pressure location for the first stage of the vehicle. Experimental data on sphere-cones were also used in computing the contribution of the payload stage. These data for the ascent vehicle are presented in Figure 1.

The computations for the entry vehicle utilized experimental data from hemisphere-cylinders for Mach numbers up to 3 and Newtonian values at Mach numbers greater than 6.0. Contributions of the four-flap flare were computed using experimental data to a Mach number of 1.2 and Newtonian values at a Mach number greater than 6.0. These data for the entry vehicle are presented in Figure 2. In order to obtain the size of such a system, it was necessary to estimate the rolling moment that could be expected during the descending trajectory. The rolling moment, in this case, was attributed to asymmetries in the vehicle, namely, an off-set center of gravity position (displaced from the axis of symmetry) and misaligned flaps (displaced from being tangent to the cylindrical portion of the vehicle). The variations of rolling torque with time during the descending trajectory are presented, for both of these asymmetries, in Figures 3a and 3b. Both trajectories originate at an altitude of 300,000 feet. A displacement of the center of gravity, $\Delta_{c.g.}$, was assumed to be .20 inches in the results of Figure 3a.

B. Flap Configuration and Pressure Distribution

Since the entry vehicle is expected to decelerate through transonic and low supersonic velocities, where the static stability or static margin of a vehicle is usually at a minimum, the configuration of the flare was chosen to stabilize the payload during this portion of the trajectory with a static margin of 5 percent of the cylinder diameter. The calculations of the flare contribution involved extrapolations from the experimental data of Reference 6 at transonic speeds and shock-expansion theory at supersonic speeds.

In order to calculate the convective heating encountered on the GEM entry vehicle, static pressure distributions were computed on the surface of the hemisphere, the cylinder, and flare for freestream Mach numbers from 2 to 10. These pressure distributions were obtained from several sources, namely, Reference 7 was used to obtain the pressures on hemispherical noses, extrapolations from method of characteristics data were used for the cylindrical body, and shock-expansion theory was applied on the flare. The variation of the surface pressure with axial position for these Mach numbers are presented in Figure 4. Similar pressures for the sphere-cone nose of the ascent vehicle are presented in Figure 5.

Designing the primary structural components of the GEM vehicle required calculation of the normal forces on the entire vehicle at the point of maximum stagnation point heating, maximum cylinder heating, and maximum dynamic pressure. The computations indicated the entry vehicle loads for the conditions of maximum cylinder heating and maximum dynamic pressure were nearly identical. These entry vehicle load distributions together with the tabulated loadings on the ascent vehicle are presented in Figure 6.

C. Evaluation of Roll Torque

The roll torque exerted on the GEM entry vehicle resulting from the combined asymmetries of an off-set center of gravity and misaligned flaps has been computed as a function of time from an altitude of 300,000 feet and is presented in Figure 7. Computations of the torque due to an off-set center of gravity include the assumptions that the average angle of attack during descent is 2° and the displacement of the center of gravity from the axis of symmetry is 0.10 inches. Assumptions made in the computations of flap misalignment torque include an assembly tolerance of $\pm .25^{\circ}$ per flap which, if computed for four flaps, results in a total design value equivalent to one flap misaligned $\pm .50^{\circ}$.

D. Tabulated Loading on the GEM Ascent Vehicle at Maximum Dynamic Pressure During Ascent

<u>Normal Force</u>		<u>Location of Errors</u>
sphere-cone	540 lb/deg	26 in. from nose
cylinder	167 lb/deg	225 in. from nose
fins	1163 lb/deg	617 in. from nose

Axial Force

sphere-cone 8300 lb.

E. Drag Contribution Due to Displacement Rocket Fairings

As the four displacement rocket fairings were added to the vehicle only recently, the resulting drag contribution was not included in Figure 1(a). Computations incorporating such effects were accomplished and are plotted in Figure 1(d).

12-19-61

Great Composite Vehicle
Speed 200 mph
Axial force = 100,000 lbs

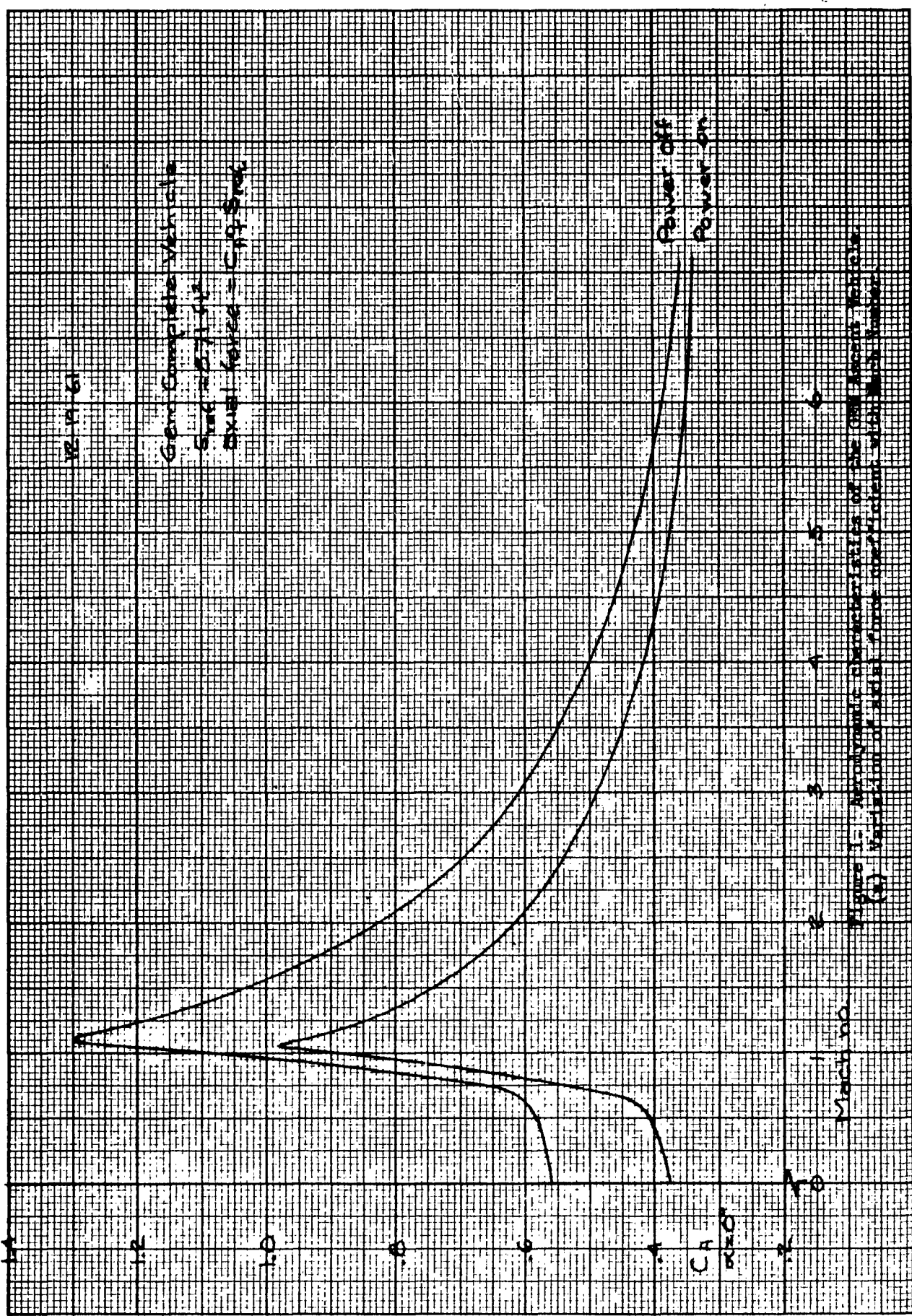

Figure 1. Approximate power levels of the Great Composite Vehicle
(a) Variation of axial force - Composite Vehicle

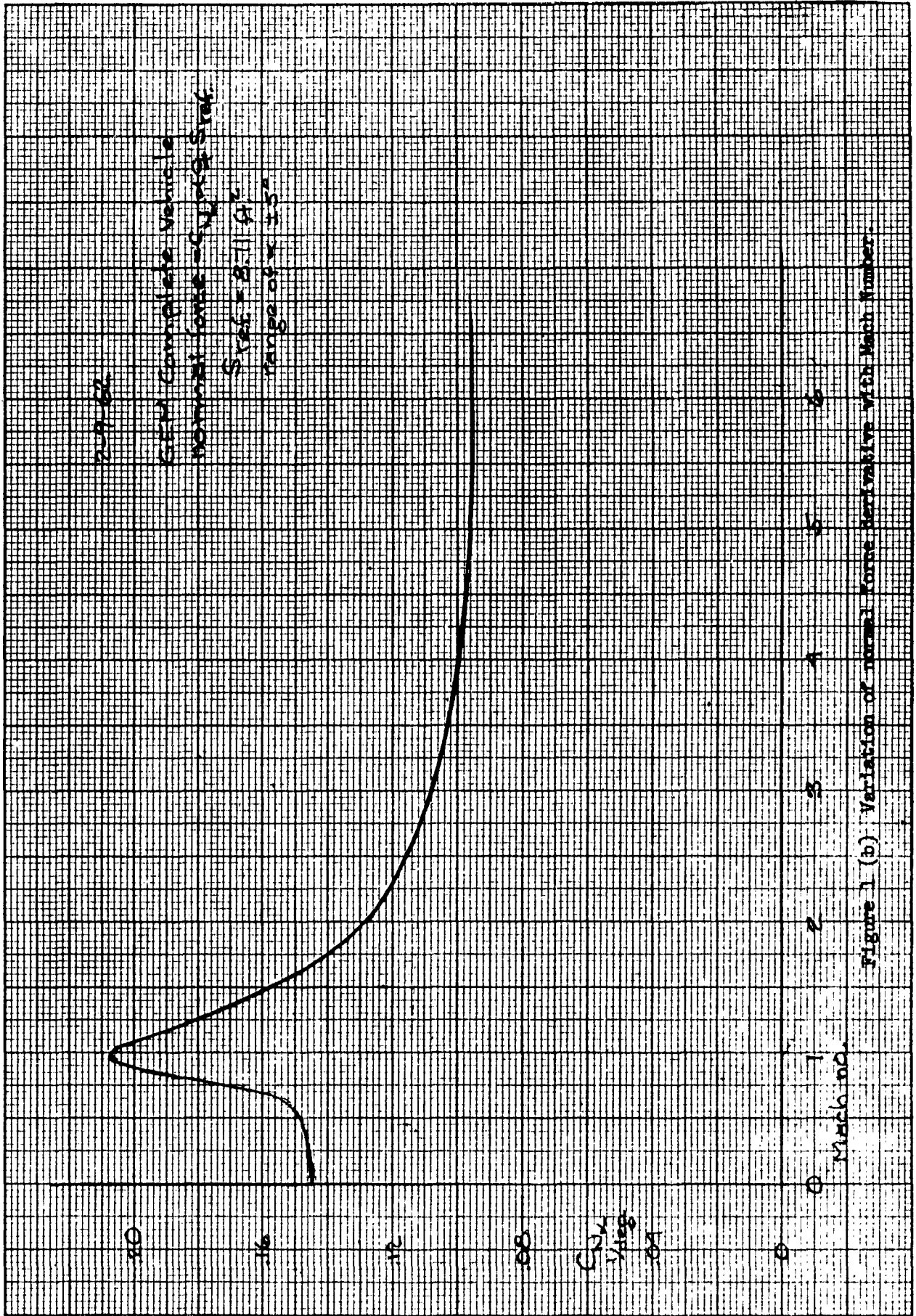

Figure 1 (b) Variation of normal force derivative with Mach Number.

2-9-67

GM complete vehicle

(center of gravity)

= 55.4 ft for Configuration A

= 55.8 ft for Configuration B

range of ± 0.2

Configuration "B"

Configuration "A"

10

8

6

4

$\frac{X_{CG}}{ft}$

2

0

Station No.

2

3

4

5

6

8

Figure (c) Variation of center of gravity with Mach Number

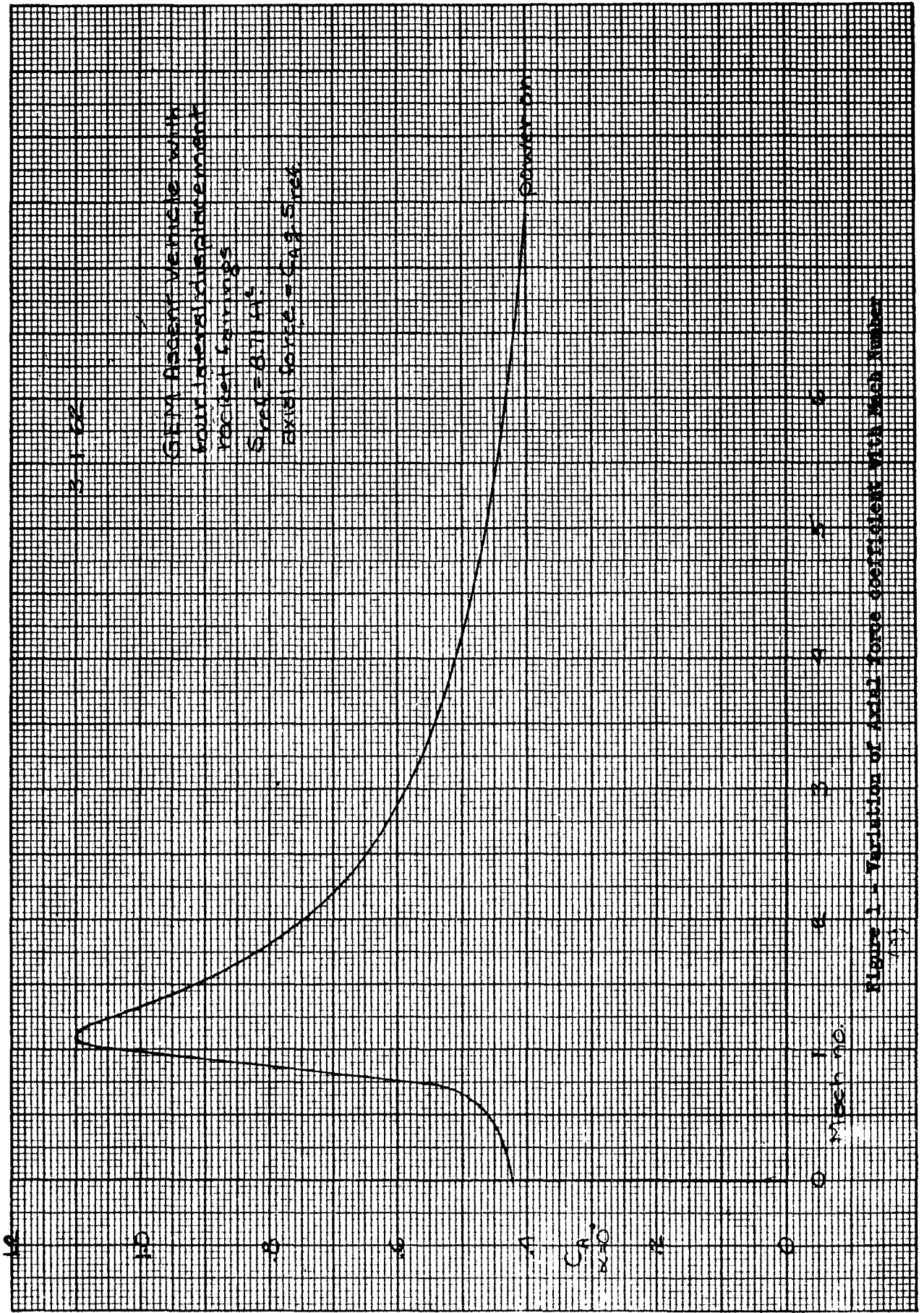

Figure 1 - Variation of axial force coefficient with mesh number

12-19-66

Chem. Engrg. Notebook
204 Claps

Overall Coeff. = 0.995
Spk. = 0.11 (1)

30

20

10
0

10

20

30

0.005
0.010
0.015

0.005
0.010
0.015

Approximate overall coefficients for the different masses
(a) Variation of overall Coeff. coefficient with Mass Number

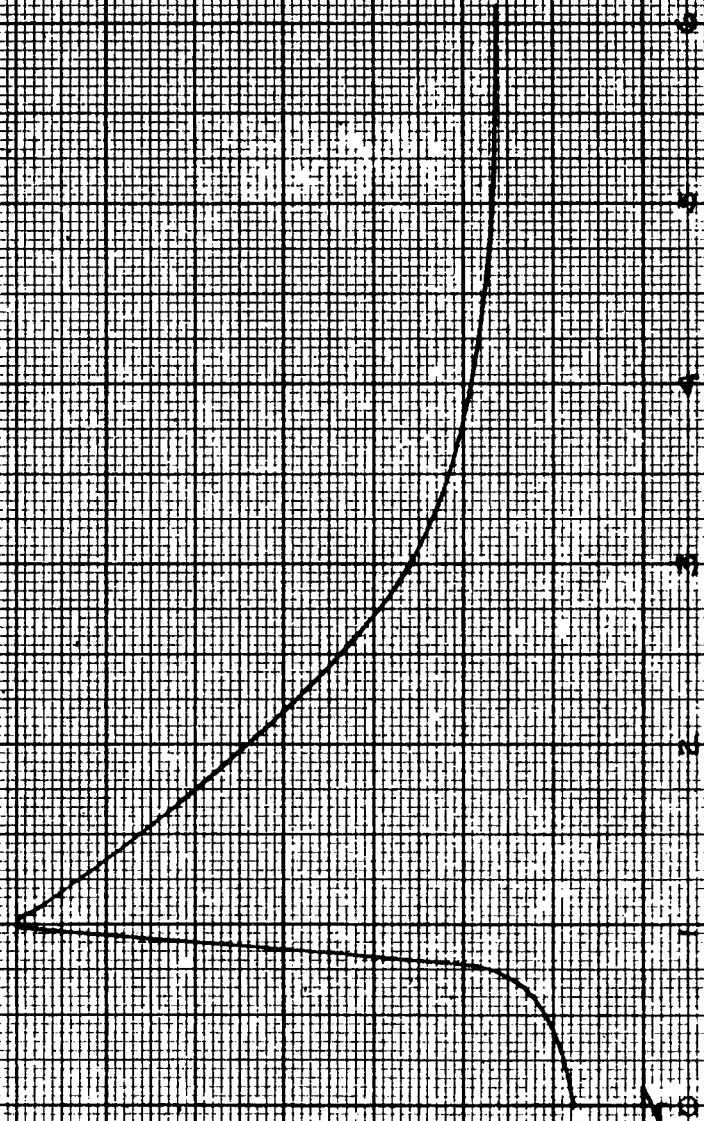

12-28-61

Gem Entry Vehicle
20° flaps

$$\text{Normal force} = C_{N\alpha} \dot{\alpha} S_{ref}$$

$$S_{ref} = 8.71 \text{ ft}^2$$

range of $\alpha \pm 15^\circ$

$C_{N\alpha}$

0.8

$C_{N\alpha}$

Ydeg

0.6

0.4

0

0

5

10

15

20

25

30

Figure 2-30) Variation of Normal Force Derivative With Mach Number.

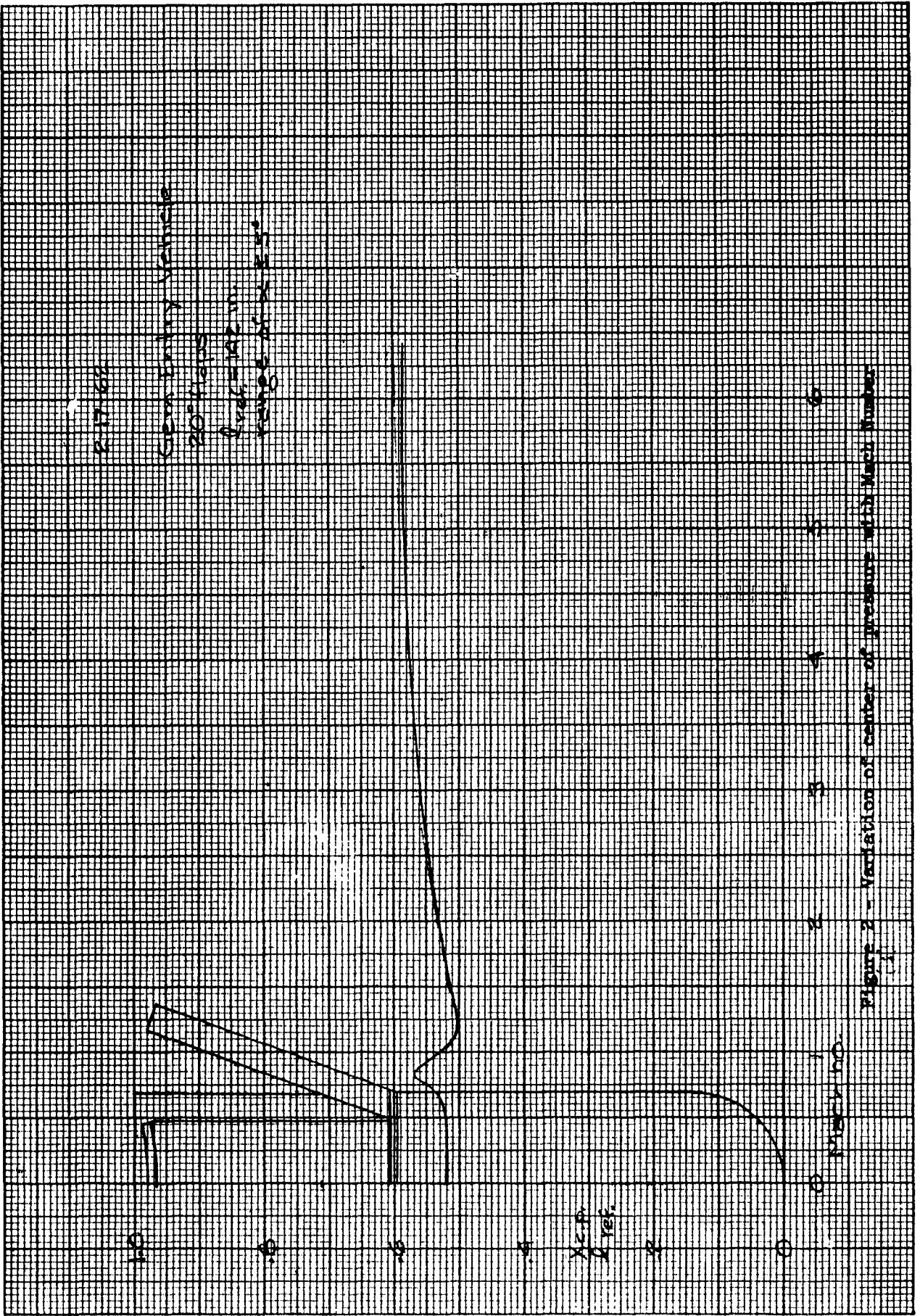

Figure 2 - Variation of center of pressure with Mach Number

Roll torque due to off-set center of gravity position on GEM

$$\text{torque} = \frac{G_{CG} \Delta y \cdot I_{CG}}{L}$$

$\Delta y = 5.580 \text{ inches}$
 $A_{CG} = 8.71 \text{ ft}^2$

no retro rocket fired (abort) $V_{ret} = 3807 \text{ ft/sec}$

retro rocket fired $V_{ret} = 3800 \text{ ft/sec}$

160

120

80

40

0
 10000
 8000
 6000
 4000
 2000
 0

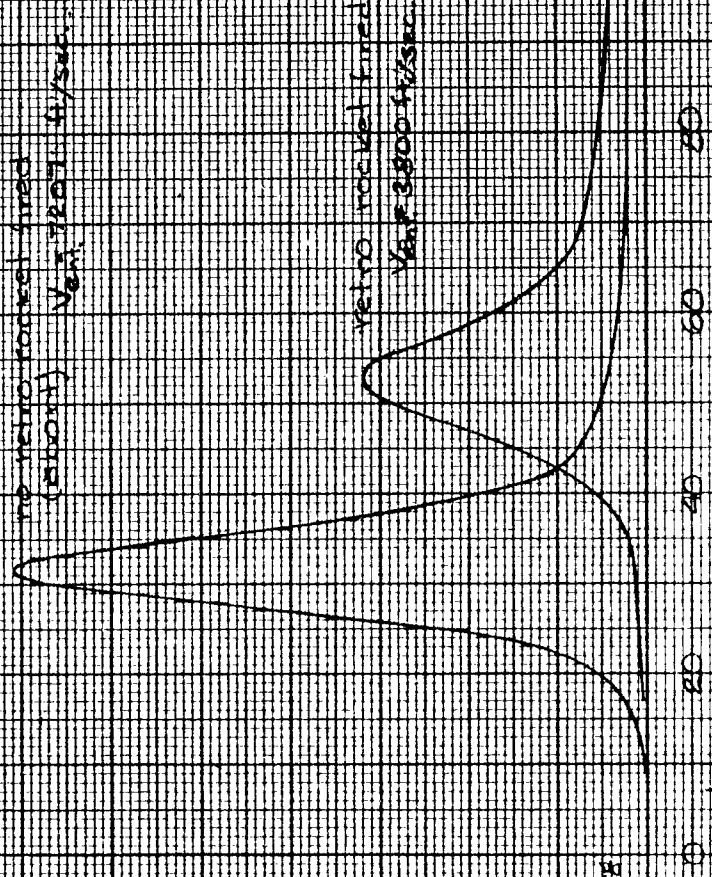
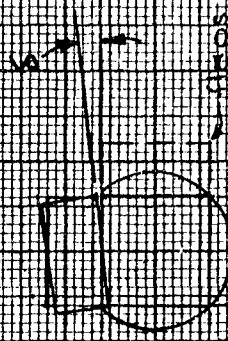

Figure 3 (a) - Variation with time of rolling moment due to off-set center of gravity position during descent of the GEM Entry Vehicle.

2-8-68

Roll torque per flap due to flap misalignment

no retro rocket fired
(sharp) $V_{air} = 7207 \text{ ft/sec}$



retro rocket fired
 $V_{air} = 3200 \text{ ft/sec}$

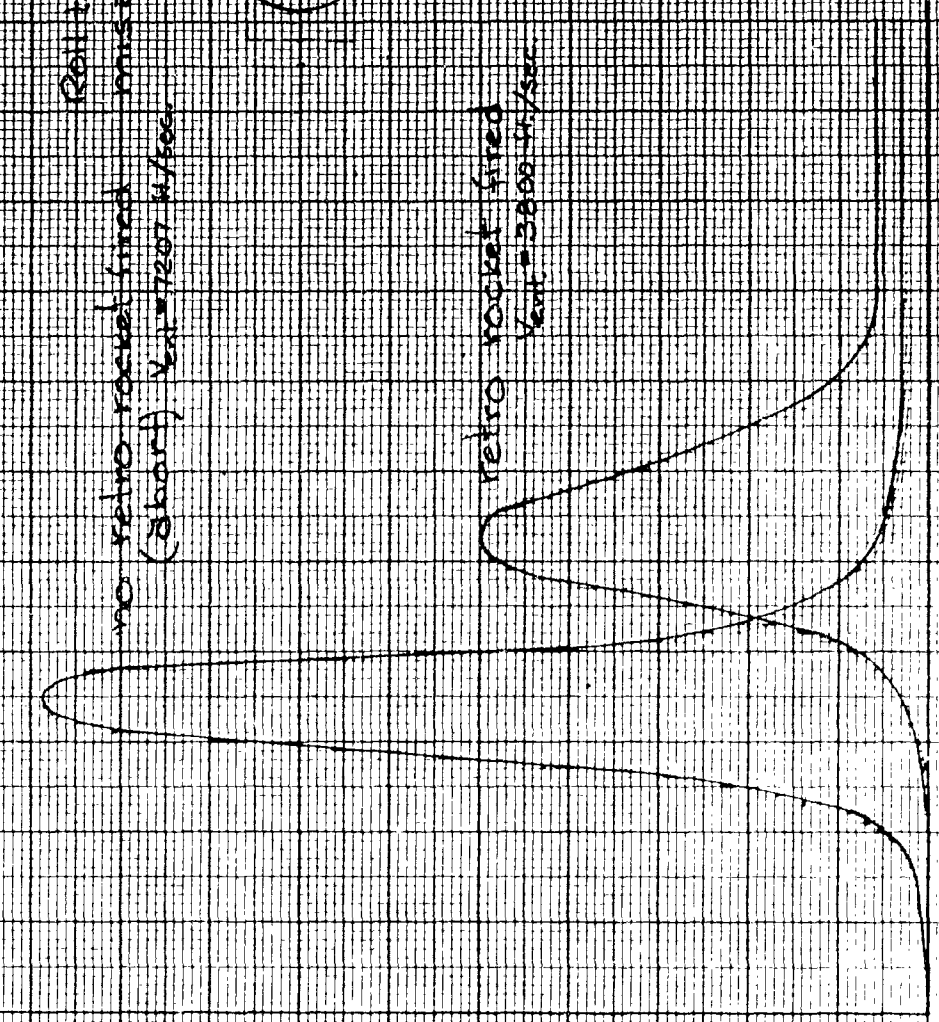

Figure 3 (b) Variation with time of rolling moment due to flap misalignment during descent of the GSM Entry Vehicle.

Pressure dist. hemisphere-sub
 P_{max} = Stagnation point pressure
 r_0 = nose radius

hemisphere + cylinder

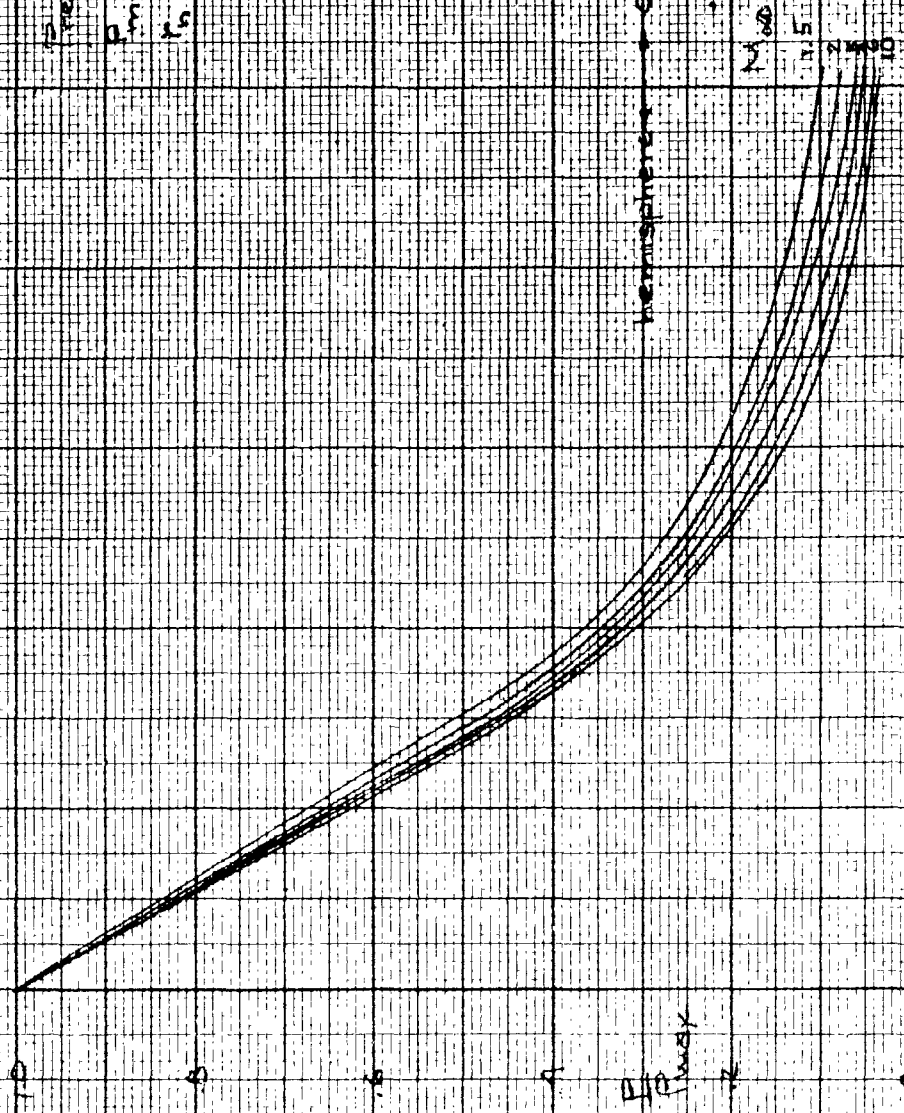

Figure 4. Pressure distributions on the half-body vehicle (a). hemispheres

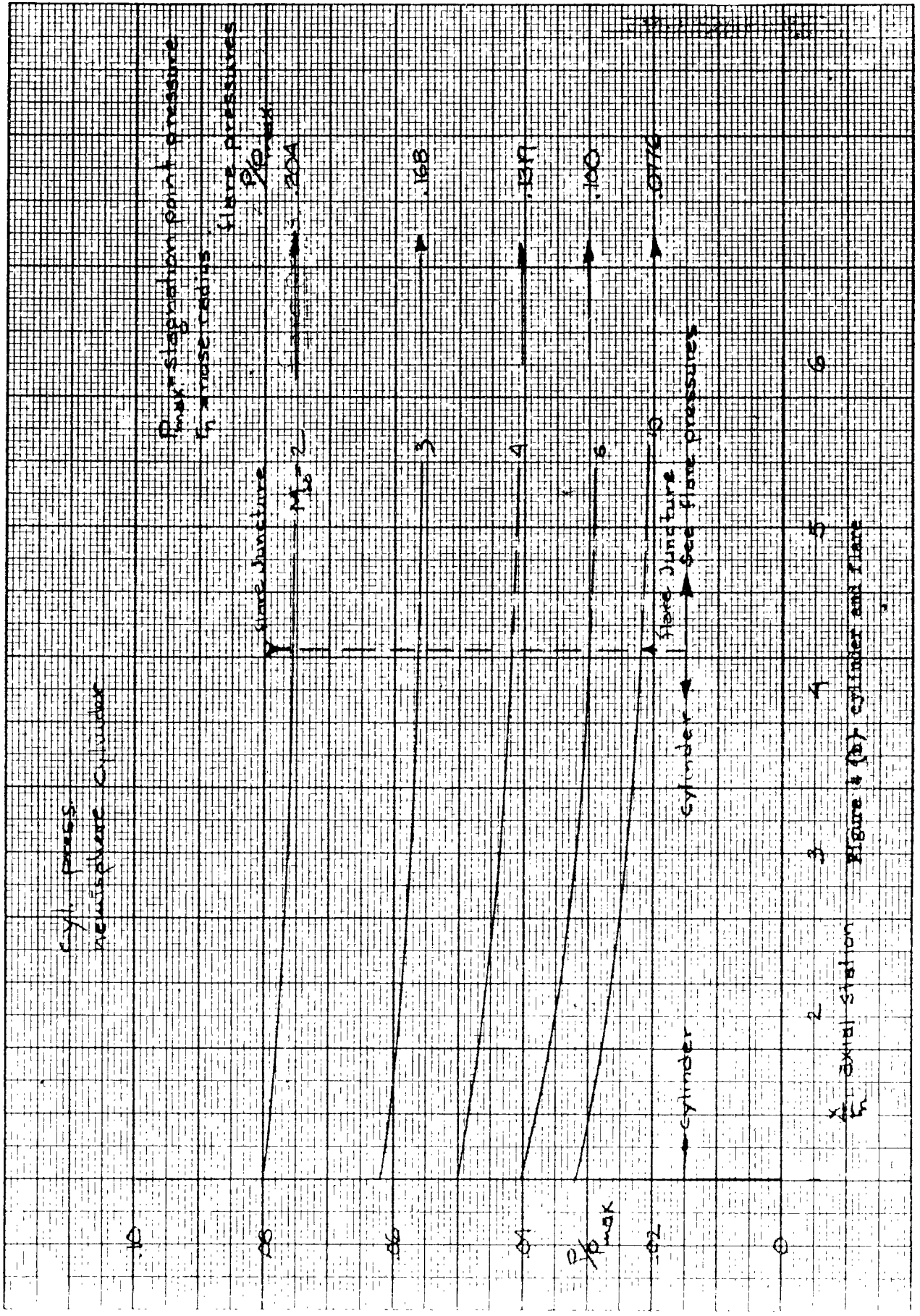

Figure 4 (b) cylinder and flare

Z-28-16

Same nose cone pressures

P_{max} = stagnation point pressure
 P_0 = nose radius

Sphere-cone juncture

Cone-cylinder juncture

Mach 2
3
4
6
10

20

18

16

14

12

10

8

6

4

2

P_{max}

0

0

1

2

3

4

5

External Station Figure 5(a) Pressure distributions on the nose cone of the GM-18000 vehicle.

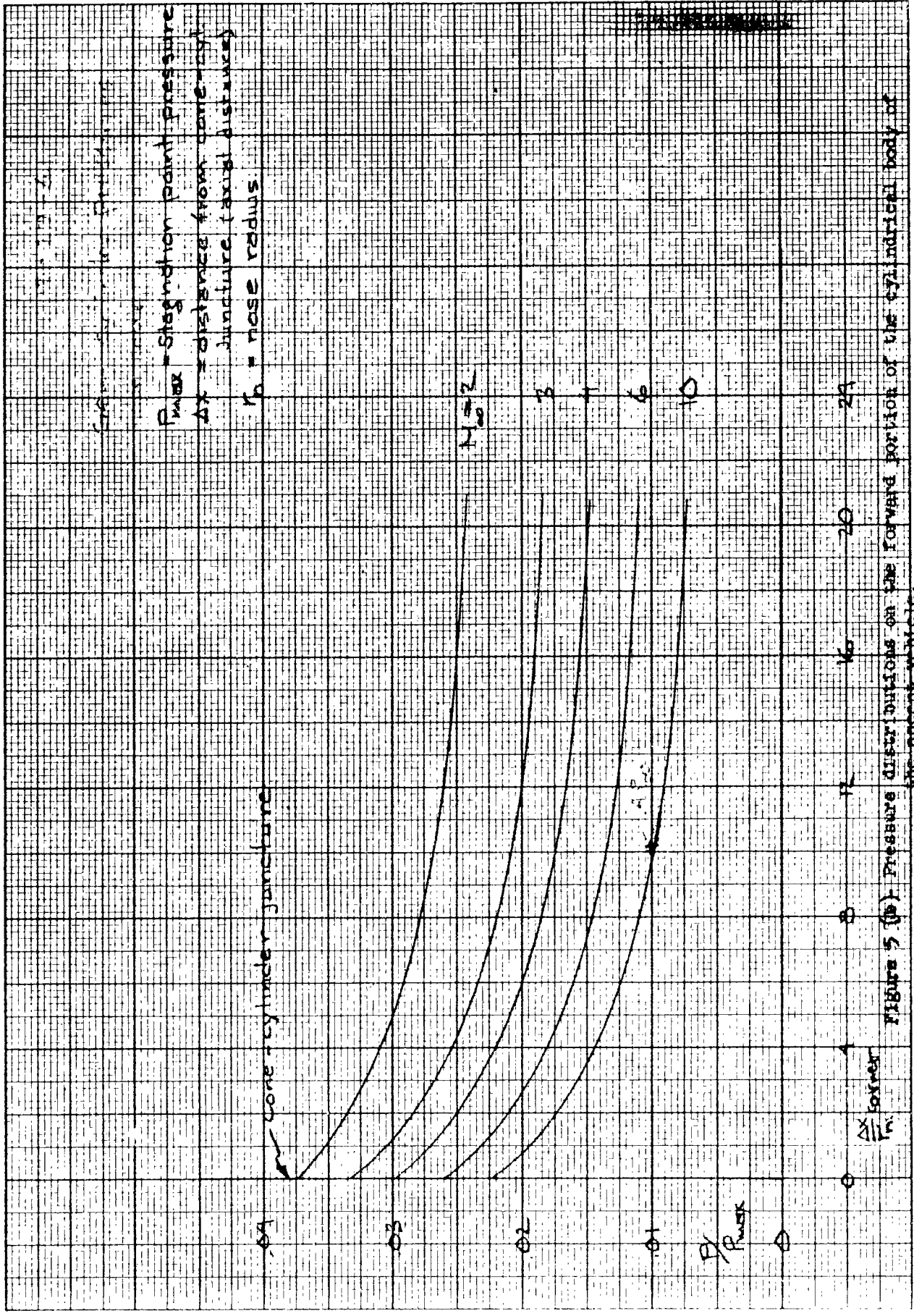

1-11-62

Pressure distribution on the
Gem nose cone during ascent
at maximum dynamic pressure

$M = 2.60$
 $h = 34,845 \text{ ft}$
 $q = 2384 \text{ lb/ft}^2$

5000

4000

3000

2000

1000

Pressure
lb/ft²

0

10

20

30

40

50

Axial distance
(in)

end of cone

Figure 6. Load distributions on the GEM vehicle
(a) Loading on the Gem nose cone at maximum dynamic pressure during ascent

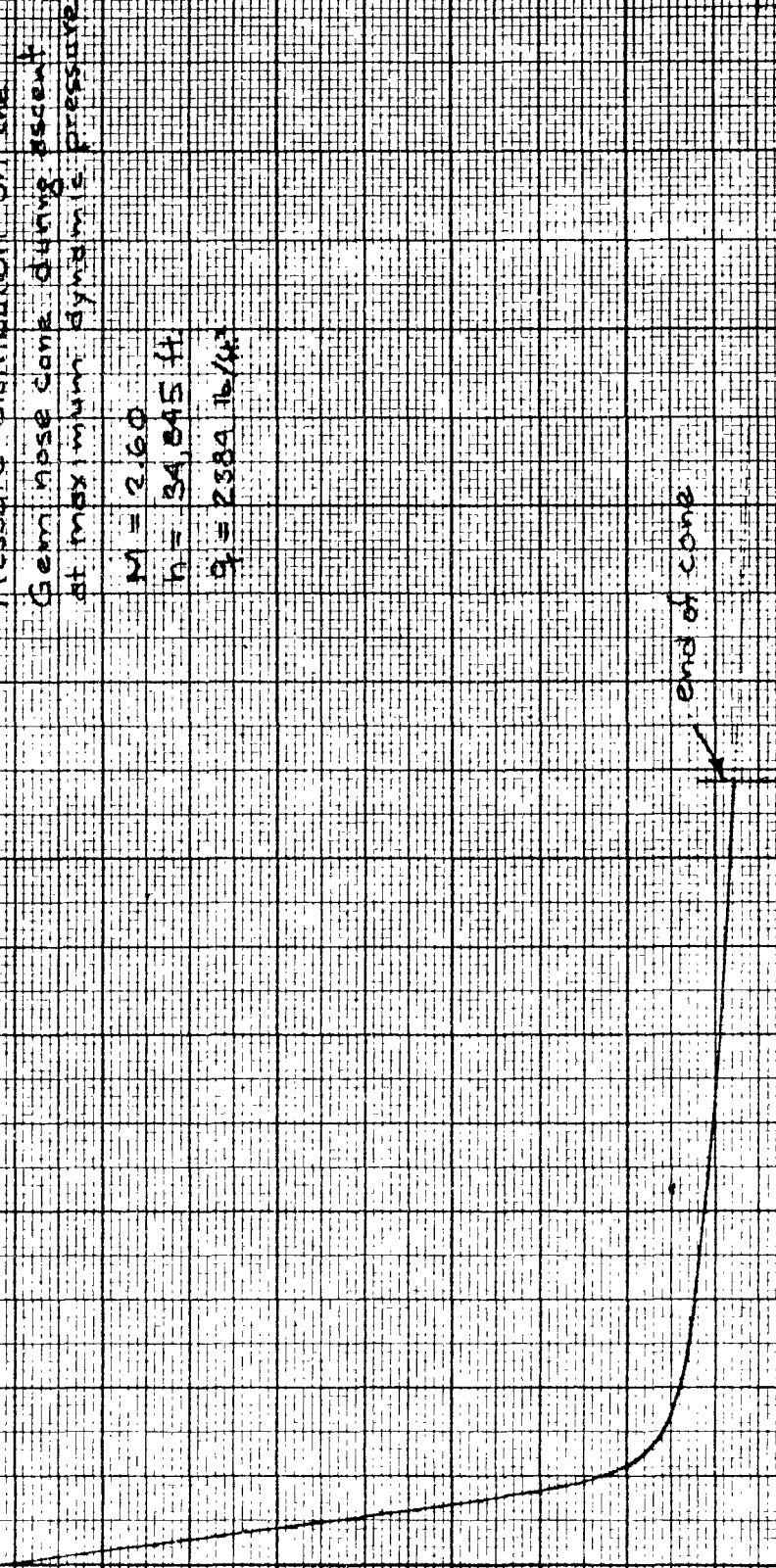

1-12-62

Pressure distribution on the
Gem entry vehicle at
maximum stagnation point
heating

$M = 6.75$

$h = 97,696 \text{ ft}$

no retro rocket fired

$q = 867 \text{ Btu/ft}^2$

2000

1600

1200

800

400

Pressure
lb/ft²

0
20
40
60
80
100
120
140
Axial distance
(inches)

hemisphere-cylinder
junction

flare junction

Figure 6(b) - Loading on the GEM Entry Vehicle during descent at maximum stagnation point heating.

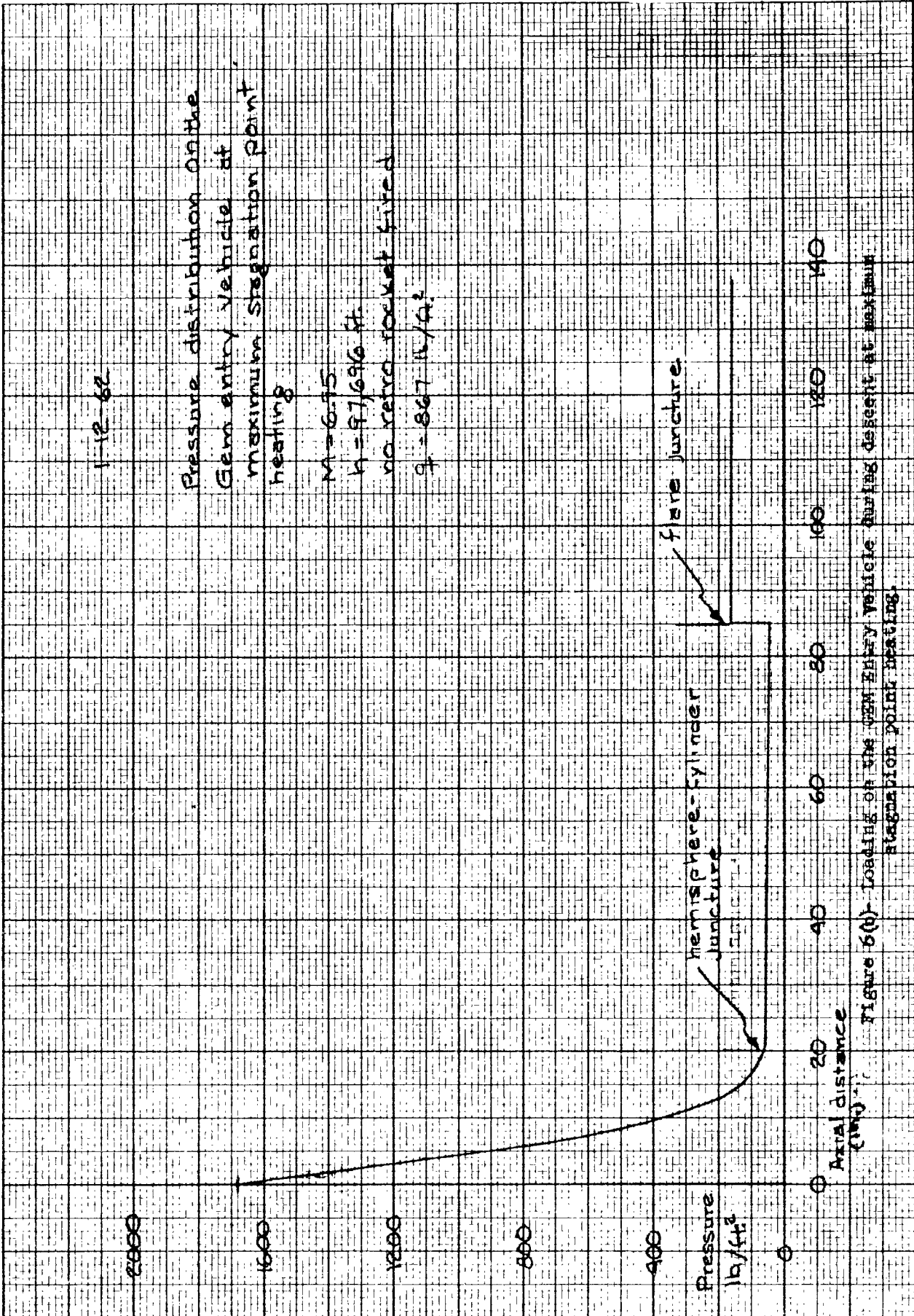

1-11-62

Pressure distribution on the

Gamma entry vehicle at maximum
dynamic pressure during entry

$M = 5.0$

$h = 70,000$ ft.

M_0 retro rocket fired

$g = 1600$ $1/4$

3000

2000

1000

Pressure
lb/ft²

hemisphere-cylinder
junction

flange junction

Axial distance
(in.)

140

120

80

60

40

Figure 6(c) Loading on the Gamma Entry Vehicle during descent at maximum dynamic pressure.

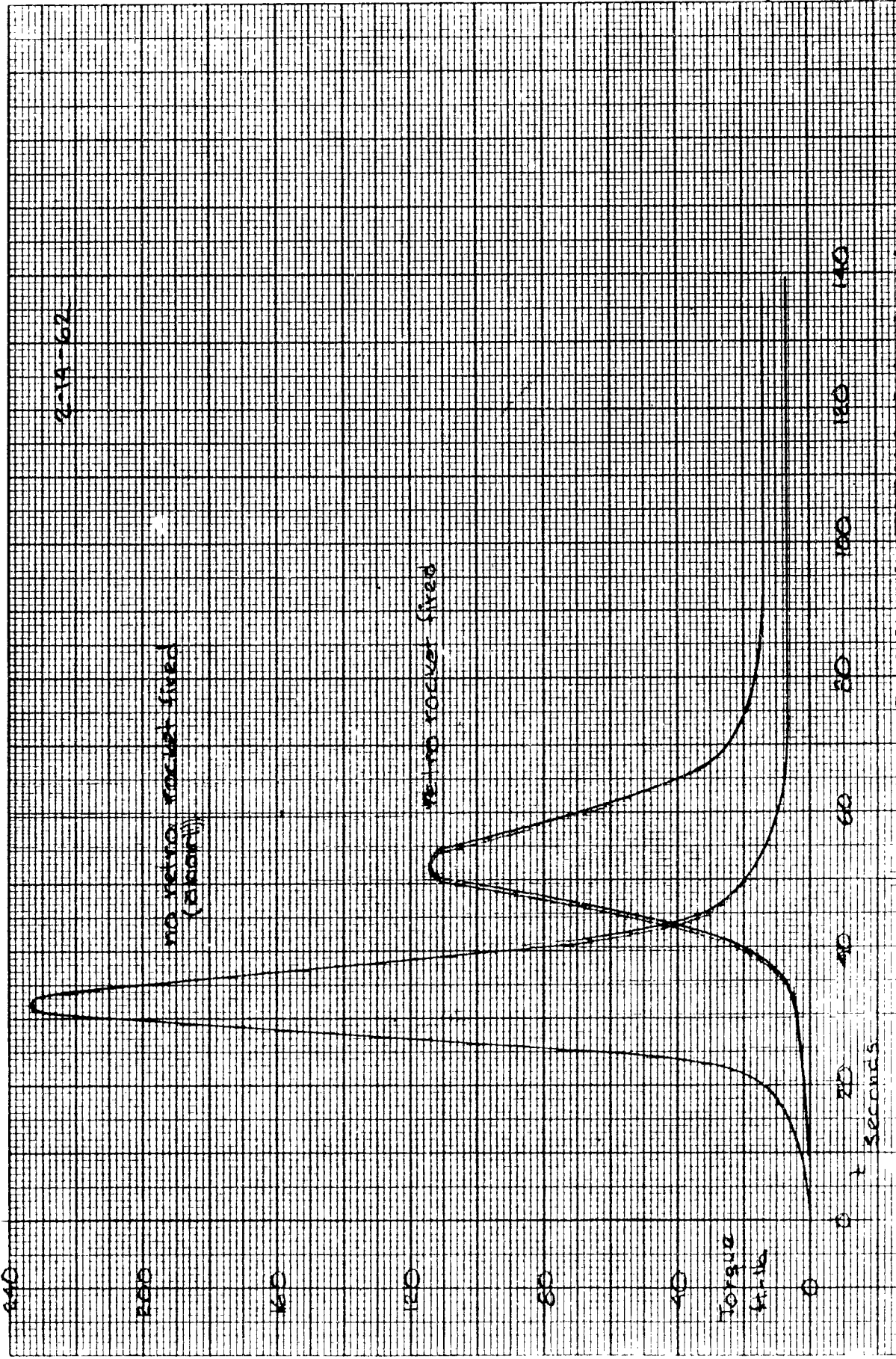

Figure 3 - Roll Torque Exerted on the GEM Vehicle during descent.

APPENDIX 5

GUIDANCE AND TRACKING AIRBORNE TRANSPONDERS AND BEACONS

Below are listed the characteristics of airborne transponders and beacons that are tentatively planned for use on GEM for range safety, radio back-up guidance, and tracking.

The actual radio tracking system to be used for the precise tracking of GEM has not yet been selected by White Sands. However, one possibility might be the MISTRAM system. Since the MISTRAM transponder characteristics are known, it was selected for use as a guide for planning and FSV (final stage vehicle) design purposes.

Except where noted, the weights given apply only to the transponder and do not include antennas, mounting brackets and associated plumbing between transponder and antenna. However, except for the X-band transponder this latter item should be small.

A.0 Range Safety

The range safety transponder will be provided by White Sands. It is radio receiving set AN/DRW-11 built by Ramo-Wooldridge, Denver. The set is designed to receive tone-modulated FM signals in the frequency range from 406 mc to 450 mc; to demodulate and filter the tone signals; and to use the tone signals to actuate control relays. Three audio channels are provided.

1.1 Environmental Characteristics

- | | |
|----------------------------------|---|
| (a) Temperature | -40°F to 160°F |
| (b) Altitude (no pressurization) | to 100,000 yds. |
| (c) Shock | 100 g's for 11 milliseconds |
| (d) Acceleration | 50 g's |
| (e) Vibration | to 2000 cps at 15 g's peak acceleration |

2. Technical Characteristics

- | | |
|---------------------|---|
| (a) Frequency range | 406 mc to 450 mc |
| (b) Sensitivity | a 2.0 μ volt signal with a \pm 30 kc frequency deviation applied to the antenna terminals will cause the proper control relay to be energized as determined by the modulating tone. |
| (c) Input impedance | 50 ohms, nominal |

3. Mechanical Characteristics

- | | |
|--|---|
| (a) Receiver volume | approx. 115 cubic inches |
| (b) Receiver external dimensions | 6 $\frac{1}{2}$ " x 4-3/4" x 3-5/8" |
| (c) Battery case volume | approx. 9 cubic inches |
| (d) Battery case dimensions
(including connector) | 1 $\frac{1}{4}$ " diameter by 7 $\frac{1}{4}$ " |
| (e) Receiver weight | 4 $\frac{1}{2}$ lbs. |
| (f) Battery and box weight | 3/4 lbs. |

4. Comments

Range safety requirements make the use of the separate battery power supply mandatory.

B. Demodulator for Back-up Radio Guidance

In order to use the range safety receiver set for radio guidance, additional demodulator channels would have to be affixed. In general, the environmental conditions would be identical to the range safety receiving set. For six additional demodulator channels, the power and weight characteristics will be as shown below.

1. Power requirements

23 to 30 volts
120 ma (half of channels activated)

2. Mechanical Characteristics

- | | |
|----------------|-------------------------------------|
| (a) Volume | 115 cu. in. |
| (b) Weight | 4 $\frac{1}{2}$ lbs. |
| (c) Dimensions | 6 $\frac{1}{2}$ " x 4-3/4" x 3-5/8" |

3. Comments

Results of missile dispersion studies may reveal that back-up radio guidance is not required. Should this be the case there will be no requirement for the demodulator for back-up radio guidance.

C. C-Band Radar Transponder for FPS-16 Tracking

The FPS-16 radar will track GEM and supply trajectory information to a computer. From the computer will come the range safety and radio guidance command information which, when coded, will be sent to the missile by way of a 400 mc transmitter. When received at the missile by the range safety receiver described in section A, (Range Safety) the signal will be demodulated by the range safety demodulators and/or the radio guidance demodulators described in B, and appropriate control or destruct relays will be energized.

Specifications for C-Band radar transponder C/T Mod 2 built by Aero GEO Astro Corporation are shown below:

1. Receiver Characteristics

(a) Frequency	5400 to 5900 mc
(b) Sensitivity	minus 65 dbm
(c) Pulse width	0.4 to 0.8 μ sec

2. Transmitter Characteristics

(a) Frequency	5400 to 5900 mc tunable
(b) Power	400 watts peak
(c) Pulse width	0.5 μ sec \pm 0.1 μ sec
(d) Repetition frequency	10 to 2000 cps.

3. Mechanical Characteristics

(a) Size	92.6 cubic inches
(b) Form	3.058" x 5 $\frac{1}{2}$ " x 5 $\frac{1}{2}$ "
(c) Weight	5.75 lbs.
(d) Pressurized	15 psi

4. Environmental Characteristics

(a) Temperature	-32 $^{\circ}$ C to + 80 $^{\circ}$ C
(b) Vibration	50 to 2000 cps at 10 g's minimum time of 3 minutes in 3 planes
(c) Shock	100 g's all planes, 11 ms duration.
(d) Acceleration	130 g's along each major axis for 3 sec duration.

5. Primary Power
 - (a) Input voltage 24.5 to 31 volt DC
 - (b) Power drain 1.2 amps at 1000 cps rate
6. Cost \$9500 in quantities of one to three.

D. X-Band Instrumentation Tracking Transponder

The following characteristics are based upon the General Electric MISTRAM transponder. However, the actual transponder used will depend upon the final selection by White Sands of an instrumentation tracking system for GEM.

1. Technical Characteristics

- (a) Transmitter power 23 dbm
- (b) Receiver sensitivity -105 dbm
- (c) Frequency

The transponder receiver receives two CW X-Band frequencies, nominally 8148 mc and 7884 mc to 7892 mc. The higher frequency (the range signal) is very stable while the lower frequency (the calibrate signal) is swept periodically from 7884 mc to 7892 mc. These received frequencies are amplified, frequency shifted by 68 mc, and re-transmitted back to earth.

2. Mechanical Characteristics

- (a) Weight 17 pounds

This weight applies only to the transponder itself. Associated plumbing will of course depend upon the location of the transponder with respect to the antennas. In the case of Minuteman, the waveguide weight is about 3.5 lbs. Minuteman also has a requirement for a VSWR monitor which weighs 1.2 lbs.

- (b) Volume 619 cu. in.
- (c) Dimensions 12½" x 9" x 5½"

3. Power Requirements

- (a) Voltage 25.2 v to 32.2 v
- (b) Current 4.5 amp to 6 amp
- (c) Power 150 watts nominal

E. Airborne Strobe Beacons (2) for Ballistic Camera Tracking

1. Technical Characteristics

(a) Light output (center of beam)	1400 beam candle power sec
(b) Peak intensity	4,000,000 candle power
(c) Range (300 mm BC-4 camera)	700 miles
(d) Flash spacing	.5 sec \pm .1 ms
(e) Number of flashes (min)	60
(f) Light pattern	$125^{\circ}125^{\circ} \times 150^{\circ}$

2. Environmental characteristics

(a) Temperature	-20°C to +55°C
(b) Vibration	8 g or 0.05 g ² /cps
(c) Acceleration	10 g
(d) Altitude	SL to 200 mi
(e) Optical assembly cover material	Vycor (1500°F strain point)

3. Mechanical Characteristics

(a) Volume	.64 cu. ft. (incl. battery)
(b) Dimensions	10" x 10" x 11" (including battery)
(c) Weight	32 lbs. (including battery)

4. Power Source

Beacon-mounted, silver-zinc remotely activated cell with capacity for 300 flashes.

5. Comments

There will be two airborne strobe beacons on GEM. The beacons described above built by GD/Astronautics have been used on the Atlas. Several of these beacons are surplus at the present time. However, there will be certain modifications required before they can be used on GEM. For example, it will be highly desirable to have as many as 400 or more flashes per flight as opposed to the present capability of the unit to produce 60. In talking to the manufacturers, it is understood that there is a trade-off that can be realized between light intensity and number of flashes. Since the maximum range requirement on GEM is almost a factor of 3 less than the range capability of the present beacons, the beacon intensity requirement could be reduced by about a factor of 9. This would also result in a significant weight reduction

because a smaller charging capacitor would suffice. There are no major problems anticipated in obtaining the larger number of flashes desired or in the integration of the units on GEM.

It is recommended that the beacons own battery power be used instead of missile power as these beacons require surge currents of considerable magnitude.

F. Summary

In summary the following guidance and tracking transponders and beacons will be carried on GEM:

1. Range safety receiver
2. Demodulator for back-up radio guidance
3. C-Band radar transponder (FPS-16)
4. X-Band instrumentation tracking transponder
5. Two airborne strobe beacons for ballistic camera tracking.

Appendix 6
ANTENNA SYSTEM
PARAMETERS

APPENDIX 6

GEM ANTENNA SYSTEM PARAMETERS

The final study on the four antenna systems for the GEM vehicle is being made. The results of this study will be based on the system parameters determined to date and outlined in detail below.

Telemetry Systems

PCM System

Frequency Band 2200 - 2290 mc

Antenna Bandwidth 20 mc

Ground Station Locations

	<u>Latitude</u>	<u>Longitude</u>
Dry Site	32° 22' 25"	106° 19' 39"
Long Ridge (SAC Peak)	32° 45'	105° 44'
Jig 5 (C-Station)	32° 21' 29"	106° 22' 9"

Mobile Station (1) as desired

Computer runs for each station and each trajectory (see Appendix 2 plots):

Slant range vs time: Figure 21 and Figure 25

Look Angle 1 vs time: Figure 22 and Figure 26

Look Angle 2 vs time: Figure 23 and Figure 27

Elevation angle vs time: Figure 24 and Figure 28

Ground receiver input signal requirements (no fade margin): -97 db

System Fade Margin: 6 db

Ground Antenna Gain: 34 db

Line Loss: 1 db

Ground Antenna Polarization: RHCP

Airborne Transmitter RF Power Output: 3 watts

FM/FM System

Parameters same as listed above for PCM System with exception of receiver input requirements of -99 dbm. Ground antennas as well as airborne antennas will be diplexed between systems.

Radar Beacon

Frequency Band: C-band 5550 - 5750 mc
Antenna Bandwidth: 200 mc

Ground Station Locations

	<u>Latitude</u>	<u>Longitude</u>
C-Station (R113)	32° 21' 29"	106° 22' 9"
King I (R122)	32° 54' 8"	106° 5' 55"
Phillip Hill (R124)	33° 26' 42"	106° 7' 54"

Computer runs for each station and each trajectory (see Appendix 2):

Slant range vs time: Figure 5 and Figure 9
Look angle 1 vs time: Figure 6 and Figure 10
Look angle 2 vs time: Figure 7 and Figure 11
Elevation angle vs time: Figure 8 and Figure 12

Ground receiver input signal requirements

Noise threshold sensitivity: -92.5 dbm
Required S/N: 12 db
Ground antenna gain: 44 db

Line losses

Receiving: 0.75 db
Transmitting: 2.00 db

Ground antenna polarization

C-Station and King I: linear vertical or C.P.
Phillip Hill: linear vertical

Ground station R.F. power output

C-Station and King 1:	3 megawatt
Phillip Hill:	1 megawatt
Airborne receiver sensitivity:	-65 dbm
Airborne transmitter R.F. power (peak)	500 watts

Command/Destructs System

Frequency band:	406-450 mc
Antenna bandwidth:	(to be determined)
Ground station locations:	

	<u>Latitude</u>	<u>Longitude</u>
C-Station (R112)	32° 21' 29"	106° 22' 13"

Computer run for each trajectory (see Appendix 2) similar to radar beacon C-Station listed above:

Slant range vs time:	Figure 5 and Figure 9
Look angle 1 vs time:	Figure 6 and Figure 10
Look angle 2 vs time:	Figure 7 and Figure 11
Elevation angle vs time:	Figure 8 and Figure 12

Ground station antenna gain:	0 db
Ground station antenna polarization:	RHCP
Ground station transmitted R.F. power (nominal):	750 watts
Airborne receiver input signal requirements:	-61 dbm

Tracking System (Interferometer) Parameters based on similarity to MISTRAM

Frequency band	7884 - 8216 mc
Antenna bandwidth	264 mc

Ground station locations:

	<u>Latitude</u>	<u>Longitude</u>
Central Station	32° 11.75'	106° 13.6'
North Station	32° 23.2'	106° 10.6'
West Station	32° 14.2'	106° 26.3'

Alternate locations:

	<u>Latitude</u>	<u>Longitude</u>
Central Station	32° 20.1'	106° 21.3'
North Station	32° 20.1'	106° 7.9'
West Station	32° 7'	106° 21.3'

Computer runs for each station and each trajectory (see Appendix 2)

Alternate location runs to be completed at later date:

Slant range vs time: Figure 13 and Figure 17

Look angle 1 vs time: Figure 14 and Figure 18

Look angle 2 vs time: Figure 15 and Figure 19

Elevation angle vs time: Figure 16 and Figure 20

Ground receiver input signal requirements: -120 dbm

Ground antenna gain: 41 db

Ground antenna polarization: (not determined)

Ground station R.F. power output (central station): 500 watts

Airborne receiver sensitivity: -105 dbm

Airborne transmitter R.F. power: 200 milliwatts

Airborne antenna phase stability requirements (see tracking section):

With respect to carrier and sideband
frequency difference .18 (10^{-6}) deg/cps

Phase rate with respect to any one ground
station during flight 30 deg/sec

At a given radius, the maximum phase
difference between the lines of
sight from the vehicle antenna and
the base line stations 15 deg

The maximum phase gradient at the given
radius with respect to time 1.5 deg/sec

APPENDIX 7

PCM CRITERIA

A. Scope

This specification covers the design and performance characteristics of the airborne PCM/FM system to be used as the guidance monitory subsystem on the GEM recoverable test vehicle. This PCM system will be used to condition guidance system voltages and convert them into 8 bit binary digital values, condition to single bit and group bi-level data from accelerometers, and accumulate these accelerometer data for transmission of the sum count. These data will be put into a serial pulse train and transmitted via the 2.2 and 2.3 KMC band.

B. General Requirements

1. Equipment

The telemetry equipment shall consist of equipment required to instrument the measurements anticipated for guidance evaluation using the GEM system (Reference 2, page 39). Development and design shall take advantage of techniques and components to keep the weight and size at a minimum. Solid state components shall be used in the electrical design to the maximum extent possible. Major equipments required are:

- a. Analog signal conditioner
- b. Multiplexer
- c. Analog-to-digital converter
- d. Programmer
- e. Accumulators
- f. Power supplies
- g. Modulator/transmitter
- h. Antenna

2. System Accuracy

a. Analog

The PCM/FM telemeter shall be capable of an over-all system accuracy of + 1 percent for input voltages from 0 to 25 cps.

b. Bi-Level Output

The system shall sample the bi-level states and combine this data into the serial output with no more than one error per 10^8 bits.

c. In-Flight Calibration

In-flight calibration techniques can be used, provided they do not interfere with the normal commutation of data. Such channels shall be provided with a commutator allocation in the same manner as data channels.

d. Environmental Requirements

All equipment used as part of the PCM telemetry system must be capable of meeting the assigned accuracy specifications when operating within the environmental conditions expected on GEM flights. These conditions are outlined in GEM Monthly Progress Report No. 2, Appendix 9.

e. IRIG Standard

All PCM telemetry equipment or formats must be compatible with the PCM IRIG standards, "IRIG Telemetry Standards No. 106-60".

C. Data

The PCM telemeter will be used to convey three distinct types of data:

1. Analog Data

These data will consist of 68 channels of data in analog form which will be signal conditioned, sampled by a multiplexer, and digitized into 8 bit binary words for insertion into the output code complex. Up to two such 8 bit groups will be contained in one telemeter word of 27 bits and the sample rate and commutator slot for each signal will be controlled by the PCM programmer.

2. Digital Data

These data will be output data from 3 to 6 inertial accelerometers and each output will consist of two square waves. The phase relation of the waves will determine the sign of the acceleration, and the rate or changes of state will contain the magnitude. Other forms of accelerometer output data will be signal conditioned prior to transmission over PCM.

The accelerometer data will be sampled at the constant rate of 3200 samples per second, which is sufficient to determine approximately 12 g's assuming symmetrical wave shapes and a quantizing level of .12 ft/sec/pulse. This sample rate and TM scheme are consistent with present Titan and Minuteman guidance systems.

3. Accumulator Data

To prevent a complete loss of test item data due to short TM dropouts, it is necessary to transmit data indicating a running summation of accelerometer output data. This summation shall be transmitted once per PCM frame (60 msec) for each of up to six accelerometers. The maximum count required for transmission is approximately 32,000 counts. Higher counts (63,000 counts expected for present GEM trajectories assuming a quantizing level of .12 ft/sec/pulse) may be obtained by automatically re-setting the accumulator

after saturation.

D. PCM Format

The format of the transmitted code will be determined by the characteristics of the PCM programmer subsystem and the ground data processing equipment. The word and frame characteristic of this system is as follows:

Bit rate	-	172.8 KC
Word length	-	27 bits
PCM frame length	-	384 words

1. Bit Rate

The bit rate of the telemeter shall be generated by a bit rate oscillation within the telemeter system. The bit rate shall be $172,800 \pm 1000$ bits/sec.

2. Word Length

The telemeter words shall be 27 bits long, including twenty-four (24) information bits and three (3) word synchronization bits. There will be two types of telemeter words, one type shall contain accumulator storage data, the other to convey analog data. Both types will contain bi-level accelerometer data. The telemeter words shall consist of the following:

a. Analog Word

Bits 1 - 3	Word synchronization
Bits 4 - 11	8 bit digitized analog data
Bits 12 - 19	8 bi-level bits
Bits 20 - 27	8 bit digitized analog data

b. Accumulator Word

Bits 1 - 3	Word synchronization
Bits 4 - 11	8 bits of accumulator data, least significant first
Bits 12 - 19	8 bi-level bits
Bits 20 - 27	8 remaining bits of accumulator data

8 bits of bi-level data will be transmitted each word time in bits 12 - 19. Accumulator data, which will be sampled at the PCM frame rate (once per 60 msec for each accumulator) will take the place of the two analog segments in any one word to be selected by the programmer.

3. PCM or Telemeter Frame

The telemeter frame shall consist of 384 words corresponding to 60 msec for the nominal bit rate. This frame rate corresponds to six cycles of the 64 word counter and permits simpler gating of the accumulator outputs. This frame size is also compatible with existing Minuteman format conversion equipment.

E. Performance Characteristics

1. Data Flow

The airborne data flow shall be as specified in Figure 1 attached.

2. Signal Conditioner

Signal conditioning is required to provide buffering and to convert low frequency input voltages into a 0 to 5 volt output range suitable for multiplexing. The signal conditioner must be capable of conditioning 68 analog functions and must be sufficiently versatile to permit the capability of monitoring several guidance systems with a minimum of down time or system modifications. The signal conditioner

presently used in the Minuteman flight test program, with re-designed modules, would be adaptable to GEM use. This unit, manufactured by Autonetics, presently has the capability of conditioning approximately 55 signals using circuits mounted on 7 plug-in modules. An eighth module contains a power supply. The unit weighs approximately 15 pounds and is $14\frac{1}{2}$ " x $9\frac{5}{16}$ " x $5\frac{1}{2}$ " in size. During ground operation, cooling air is required to be forced over the external surface of the conditioner box. The box is pressurized at 16 psi with nitrogen. Power requirements are +28 V DC at 25 watts. As an example of the module requirements, the following signal conditioning circuits would be required to instrument two (2) Minuteman guidance systems:

Phase sens. demod.	-	12
Non-phase sense demod.	-	4
Fixed attenuator/biased voltage divider	-	40
Temperature bridge circuits	-	4

3. Multiplexer System

The PCM multiplexer shall be capable of multiplexing 68 analog signals, 24 bi-level signals, and the outputs of 6 accumulators.

a. Analog Multiplexer

The analog multiplexer shall multiplex any combination of 68 analog signal inputs and shall provide this data to the analog to digital converter. Paralleling up to 67 multiplexer data shall not degrade the accuracy of the multiplexer.

b. Bi-Level Gates

Up to 24 channels of bi-level digital data shall be sampled at the basic bit rate in groups of eight. Each group of eight shall be called a bi-level set. Bi-level set No. 1 shall appear in bits 12 - 19 of each odd word and bi-level set

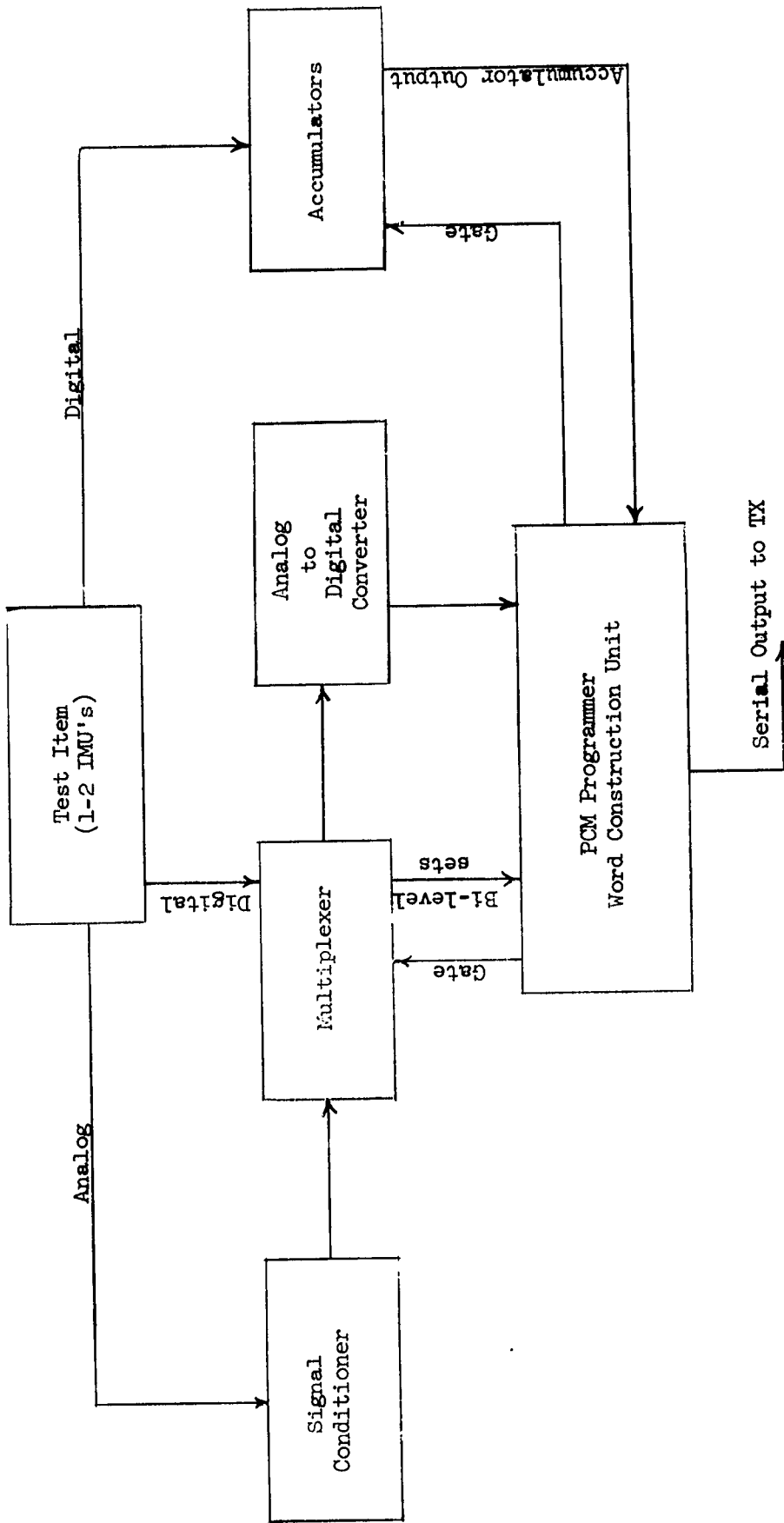

Figure 1. DATA FLOW

No. 2 in bits 12 - 19 of each even word. Bi-level set No. 1 shall contain data from one set of (3) accelerometers with two spare bits. Bi-level set No. 2 will contain data from a second set of three (3) accelerometers also with two (2) spare bits. Bi-level set No. 3 shall replace an analog word in any word to be controlled by the programmer. Maximum rate of this set is 6 samples per frame.

c. Accumulator Gates

Sixteen (16) channels of bi-level data shall be sampled for each of six accumulators. These data will be sampled once per PCM frame of 60 msec and will take the place of two analog samples in any TM word which will be controlled by the programmer.

4. Analog-to-Digital Converter

The ADC shall convert each multiplexed analog signal to an 8 bit digital value with most significant bit outprinted first. These data will be combined with other system data into the output code. Data may be contained in bits 4 - 11 or 20 - 27 of any TM word.

5. Programmer

The programmer shall combine the three types of data into a serial output of the desired format. It shall provide all clocking pulses necessary to perform bi-level sampling, accumulator sampling, and digital conversion. In addition, the programmer shall provide all word synchronization bits and synchronizer words.

a. Bit Rate Oscillator

The bit rate shall be controlled by an oscillator within the programmer to $172.8 \pm 1 \text{ KC}$.

b. Synchronization Codes

The programmer shall provide a 3 bit word code in the first three bits of every 27 bit word. The programmer will generate this word rate based on the bit rate oscillator output. At the end of the PCM frame of 384 words, a unique synchronization word shall be generated by the programmer. It should appear as the first word in the next frame and shall contain a separate word synchronization code with the twenty-four bits following to be an alternate 10 code beginning with a 1 in bit position 4.

6. Multiplexer/Programmer/Accumulator Availability

It is proposed that a modified Titan PCM system be used for the multiplexer, programmer, analog-to-digital converter, power supply and word construction unit combination. Secondary functions also include output filtering and RZ to NRZ conversion. Several types of PCM equipment have been developed for Titan evaluation. The one most suitable for adaptation to GEM usage was designed for Titan II flight test evaluation by Radiation, Inc. Both EPSCO and T. I., however, have also built similar units for non-guidance Titan purposes. Additionally, Radiation, Inc. has done some studies on modifications to the Titan II system, some of which are directly applicable to GEM usage. The sampling capacity of the PCM system for GEM is as follows:

16 bi-level signals	-	3200 samples/sec
8 bi-level signals	-	100 samples/sec
96 bi-level signals	-	16-2/3 samples/sec

12 hi-level (0 - 5 V) analog signals - 200 samples/sec
32 hi-level analog signals - 100 samples/sec
24 hi-level analog signals - 16-2/3 samples/sec

The major departure from existing hardware lies in the requirement for accumulators for 6 accelerometers. These accumulators should be built into the existing PCM unit if possible. The input to each accumulator will be two pulse trains 90° out of phase. The input circuitry must be capable of determining the number of changes of state between the two pulse trains, this number being the one required to be added to (or subtracted from) the accumulator. Additionally, the sign of the pulse(s) is determined by whether pulse train A or B is leading. This must be sensed so that the pulses may be added or subtracted as required.

Based on present GEM trajectories and accelerometer quantizing levels ($\approx .12$ ft/sec/change of state), it would be desirable to have a counter capable of counting approximately 60,000 counts (a 16 bit counter, capable of counting 65,536 counts). However, because the PCM accumulator output transmission is limited to 16 bits, a 15 bit counter should be used with 1 bit left for a sign bit. This 15 bit counter (32,768 count) must be capable of automatic re-setting after saturation as many times as required. No count of the number of resets is required.

The requirements of the accumulator and associated circuits are outlined below:

Input Logic

- (1) Determine number of changes of state (combination of two pulse trains).

- (2) Determine sign of acceleration by phase between pulse trains.

Counter

- (1) Minimum capacity approximately 32,000 pulses.
- (2) Count both positive or negative based on state of input lines.
- (3) Assign sign to output (most significant bit) depending on net number of positive or negative input pulses (2's complement may be outputted for negative numbers).

7. Transmitting Equipment

The PCM output code complex shall frequency modulate a radio frequency carrier with the following characteristics. The output modulating signal will be a non-return-to-zero signal where one level represents a "1" state and the second level a "0" state. Each level shall create a carrier frequency deviation of equal amount on each side of the assigned frequency. The frequency of the carrier shall be in the band 2.2 to 2.3 KMC and shall be within .005 percent of the assigned frequency. Frequency stability under flight environment shall be \pm .005 percent; power output shall be 5 watts minimum. More detailed specifications for the PCM transmitting equipment (including antenna) may be found in the specification written for the GEM FM/FM system.

17

Appendix 8
TM/TM COLUMBIA

APPENDIX 8

FM/FM CRITERIA

A. Scope

This document establishes the design criteria for the FM/FM telemetry systems required for the monitoring and ground stations recording of certain vehicle measurements for the flight tests and evaluation of the GEM program. The requirements stated in this document shall be used in the preparation of relevant equipment specifications.

B. General System Requirements

1. Equipment (Airborne)

The FM/FM telemetry system shall consist of equipment required to instrument the measurements listed herein. The design shall take advantage of techniques and equipment to keep weight and volume to a minimum consistent with reliability under the required environment. State-of-the-art off-shelf solid state components shall be compatible and meet the FM/FM telemetry requirements and standards as specified in the current IRIG document 106-60 (Telemetry Standards).

Two commutated 15 channel FM/FM systems are required to measure, transmit, receive, and record GEM vehicle measurements. Each system shall provide both continuous and commutated (time division multiplexing) channel information.

a. Airborne Package

The FM/FM airborne package shall contain fifteen IRIG sub-carrier oscillators for converting the transducer output voltages to channelized subcarrier frequencies. For transducer outputs in the low signal level regions such as produced by thermocouples,

strain gauges and similar transducer types, the system shall contain up to six millivolt subcarrier oscillators. Each millivolt oscillator shall have an input range of + 10 millivolts or 0 to 20 millivolts and produce 3 volts output minimum.

In addition to the oscillator complement, the package shall contain voltage regulators, line filter, RF filter, power supply, and a composite signal amplifier to insure adequate modulation of the FM transmitter. The input to the package shall be the output voltages of the transducers. The output of the package shall be a composite signal of all subcarrier oscillators. Intermodulation distortion and radiated and conducted noise characteristics shall be within the limits specified in current MIL-I-6181. The package shall be powered by the 28 V DC missile supply and require a maximum of 1.5 amperes.

b. FM Transmitter

The composite signal output of the airborne package shall modulate an RF carrier frequency in the 2.2 to 2.3 KMC band provided by a suitable airborne transmitter. In specifying bandwidth, the transmitter and receiver shall be considered as a system and shall be a minimum consistent with efficient utilization of the frequency spectrum. The transmitter shall be designed within the following general limits:

(1) Frequency Stability

The transmitter RF carrier, including drift and all other variables, shall be within 0.005 percent of the assigned carrier frequency.

(2) Radiated Power

5 watts RF output minimum.

(3) Spurious Harmonic and Fundamental Signals

Conducted by power leads or radiated directly from equipment or cable (except antenna) shall be within the limits specified in the current MIL-I-6181.

(4) Linearity

At least 1 percent of the best straight line.

(5) Frequency Accuracy

Within 0.005 percent of the assigned carrier frequency.

(6) Output Frequency Range

Any frequency within the 2.2 KMC to 2.3 KMC telemetry frequency band.

(7) Weight

Less than 12 pounds including power supply.

(8) Adjustments

Absolute minimum consistent satisfactory operation.

(9) Cooling

Heat sink cooling only.

(10) Primary Power

28 volts DC 4 amperes maximum.

(11) Warm-Up Time

Less than 2 minutes to full RF output.

(12) Environmental Conditions

Transmitter unit shall be capable of operating within the above requirements throughout the GEM temperature, vibration, shock, acceleration, and pressure environment. Unit

shall be designed to operate in outer space and shall be enclosed in pressurized housing.

c. Commutation

Commutation (time division multiplexing) shall be used to expand the data handling capacity of the system. Certain vehicle measurements such as vibration and temperature are too numerous to assign each a subcarrier channel. The transducer outputs will be time division multiplexed using a mechanical motor driven commutator switch. Input commutations shall be used, i.e., the input of a subcarrier oscillator is switched to the output of a number of transducers. The commutator switch used shall be designed to operate not less than 200 hours before requiring drive motor brush replacement. In addition, the unit chosen for the GEM FM/FM subsystem shall be an off-shelf commutator switch of the highest demonstrated reliability and low power consumption not exceeding 5 watts power average. Table II (Commutation Rates) of the current IRIG Telemetry Standard 106-60 shall be adhered to.

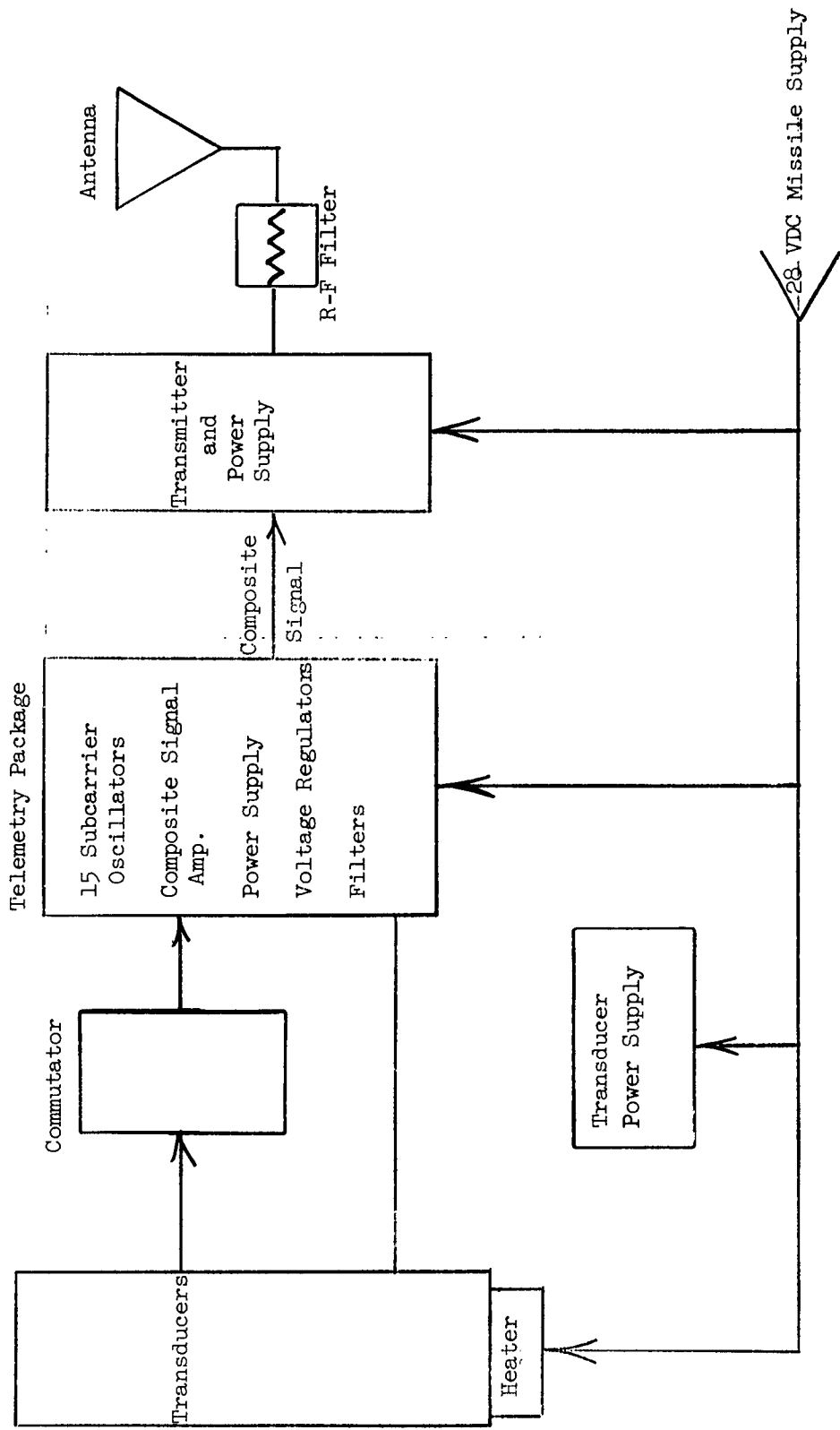

BLOCK DIAGRAM FM/FM TELEMETRY SYSTEM

Figure 1.

TABLE I

FM/FM EQUIPMENT LIST

	No. Required	Total Weight (lb.)	Total Volume	Total Power Required Avg. Watts
Telemetry Package	2	15	420	125
XMTR	2	24	490	225
Commutator	4	6	420	20
Transducer Power Supply	2			
Transducers	61			

TABLE II

VEHICLE MEASUREMENT LIST

FM/FM Telemetry			
Measurement	Quantity	Intelligence Freq. cps	Range
Vibration	10	1200	± 20 g's
Temperature	10	0.05	50 - 150° F.
Strains	10	220	
Events Monitor Ignition, Separation, etc.	6	Switching (Discrete)	
Monitor Chamber Pressures	2	160	0 - 10 V DC
Power Supply	2	1.0	0 - 20 V DC
Vehicle Accelerations	1	20	± 10 V DC
Vehicle Attitude	3	25	0 - 5 V DC
Control System Parameters, Vane Positions	16	1-2	0 - 10 V DC
Confirmation of Signal Receptions	1	1-2	0 - 5 V DC

2. Equipment (Receiving Station)

The equipment provided for the GEM ground stations shall be a combination of the latest modern units compatible with the airborne FM/FM systems as regards bandwidth and performance.

The ground receiving stations shall perform the following functions:

- a. Receive an FM/FM telemetering signal.
- b. Tape record the timing signals and the composite signals.
- c. Demodulate the 15 subcarrier channels.
- d. Record the data signals on an oscillograph recorder.
- e. Monitor and analyze the individual subcarrier signals.
- f. Test and calibrate the station with self-contained equipment.

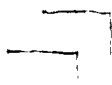

Appendix 9
TEST ITEM INTEGRATION

APPENDIX 9

TEST ITEM INTEGRATION

(PAGES 152 THRU 158)

This Appendix is classified and will be transmitted under separate cover.

APPENDIX A
STELLAR/INERTIAL TEST
FIXTURE DESIGN REQUIREMENT

APPENDIX 10

STELLAR INERTIAL TEST FIXTURE DESIGN REQUIREMENTS

1. PURPOSE

The purpose of the GEM stellar-inertial test fixture, its associated electronics computers and ground support equipment is to provide a means for evaluating typical inertial and stellar guidance components such as gyroscopes, accelerometers, velocity meters, and star trackers on the GEM prior to their integration into a guidance system. The GEM/SITF will be a flexible Inertial Measurement Unit serving as a test bed for GEM flights involving component testing. The GEM/SITF will not be used to guide or control the GEM. Inflight guidance of the GEM will be accomplished by an autopilot described elsewhere.

II. SUBSYSTEMS

The GEM/SITF subsystems will consist of, but not be limited to:

A. Airborne Equipment

1. The stellar inertial measurement unit
2. The airborne digital computer (Buffer)
3. Interface to power supply (28 V.D.C.), signal conditioner and pulse code modulated telemeter multiplexer.
4. Voltage regulator.

B. Ground Equipment

1. IMU checkout, erection and launch set
2. Azimuth alignment set
3. IMU test monitor console
4. IMU data recorder
5. Ground digital or analog computer
6. Ground support equipment

III. SYSTEM MODES

The GEM/SITF will operate in, but not be limited to the following modes:

- A. Inertial
- B. Gyro drift test
- C. Accelerometer or velocity meter calibrate (which may be accomplished by pre-set counters)
- D. Stellar acquire (in-flight)
- E. Ready
- F. Erection and alignment

IV. GENERAL REQUIREMENTS

- A. The velocity errors contributed by components other than the gyros, accelerometers and stellar sensors shall not exceed $.07 \text{ ft}/\widehat{\text{sec}}$ RMS for typical GEM trajectories. This is roughly equivalent to $\pm 2 \text{ sec}$ total erection error for presently planned trajectories
- Azimuth erection uncertainty shall not exceed $\pm 5 \widehat{\text{sec}}$.
- B. The life of the system will be equivalent to a mean time failure under pre-launch environment of 1000 hours which is equivalent to a reliability of .99005 for 10 hours in pre-launch modes or 100 hours mean time to failure in the flight environment which is the equivalent of .99005 reliability for 1 hour in the flight environment. (This requirement is meant to insure the ability to move through a 10 hour countdown or 6 flights without the need for a major overhaul of the system). (A major overhaul is any overhaul that cannot be performed in AFMDC shops in less than five working days).
- C. Reaction Time: Since the GEM/SITF is strictly an experimental support system, reaction time is not critical, however erection should be accomplished in a reasonable length of time for Test Day count-down procedures such as 45 minutes and the system should be able to hold in the ready mode for periods of at least 3 hours. Elapsed time from turn-on to ready shall be less than four hours.
- D. Interchangeability: Since the GEM/SITF will be used as an R and D test fixture it will be essential to provide means for accepting gyros, accelerometers and star sensors of unknown design. The holding fixtures will be specified in outline only so that they may, in turn, be modified depending on the component being tested.

V. STANDARD COMPONENTS AND SUBSYSTEMS

A. Airborne Equipment

1. The stellar inertial measurement unit
 - (a) Outer or pitch gimbal with $\pm 90^\circ$ of freedom which will allow access to the platform for alignment and stellar work.
 - (b) Middle or yaw gimbal with $\pm 180^\circ$ of freedom which will allow access to the platform for alignment and stellar work.

- (c) Inner (roll) gimbal (platform with $\pm 90^\circ$ of freedom either side of the target azimuth which will be stabilized by 3 SDF gyros or 2 TDF gyros and will carry the stellar sensors and accelerometers mentioned below.
- (d) Three gimbal position pick-offs for sensing inner middle and outer gimbal positions.
- (e) Three gimbal torque motors for a stabilization subsystem.
- (f) Two elevation pendulums or bubble levels on platform for erection of the system.
- (g) Two reference pendulums or bubble levels on platform for erection of the system.
- (h) An azimuth mirror for erection of the system which will have 360° of freedom with respect to nominal target azimuth so that theodolite position can be fixed relative to launch pad, irrespective of star tracker location.
- (i) Gyro fixtures for mounting two gyro test specimens such that spin and input axis are not parallel to inertial up on one gyro and parallel on the other.
- (j) Gyro fixtures on the platform to accommodate two degree of freedom gyros. The coordinate systems will be x, y and z (north, west and up). These gyros will be used to stabilize the platform.
- (k) Two accelerometers normal to thrust for measuring velocity components due to drift.
- (l) Accelerometer/velocity meter fixtures on the platform to accommodate 2 orthogonal accelerometers in the x, y, z (north, west, up) system as test specimens.
- (m) Two star tracker fixtures to accommodate two unspecified trackers on the platform.
- (n) Optical alignment provisions for measuring incremental misalignments between theoretical x, y, z and actual x', y' and z'.
- (o) Fine balancing slugs for gimbals and platform. Since the GEM/USITF must accept unspecified components, provision must be made for achieving fine balance of platform and gimbals once test components have been installed.
- (p) A stabilization subsystem capable of operating on three unspecified signals from 2 TDF gyros and an azimuth signal from one star tracker. Subsystem will use redundant azimuth drift signals to minimize azimuth drift.
- (q) Airborne heat sink will be provided to absorb 30 BTU's/hr. for 12 minutes.

2. The airborne computer (buffer) will consist of:
 - (a) Conditioning and sampling input device
 - (b) Four accelerometer accumulators capable of non-destruct read-out twice per second.
 - (c) Essentially a buffer device, the airborne computer should provide for the insertion of additional circuit modules in card form as required.
 3. The Airborne Interface
 - (a) Interface between the IMU, the computer and the GEM will be provided as a subsystem of the USITF.
 - (b) Interface between the IMU, the computer and the GEM telemetry system will be provided as a subsystem of the USITF.
 - (c) Voltage and frequency regulation will be a part of the airborne interface.
- B. Ground Equipment
1. The IMU checkout erection and launch set will:
 - (a) Provide means for pre-flight check-out of the USITF.
 - (b) Provide means for erecting the platform to $2 \widehat{\text{sec}}$ using signals from an azimuth alignment set, the pendulums and the gyroscopes.
 - (c) Provide necessary launch controls for the USITF.
 2. The Azimuth Alignment set will:
 - (a) Provide means for azimuth alignment of the GEM/USITF.
 - (b) Provide a light source for alignment of the star trackers.
 3. IMU Test Monitor Console will:
 - (a) Provide means of monitoring all test functions prior to flight.
 - (b) Provide telemetry on-off controls.

B. Ground Equipment (Continued)

4. IMU Data Recorder will:
 - (a) Provide means for recording up to six signals (digital) on punched paper tape.
 - (b) Provide means for recording up to six signals as Sanborn or pen traces.
 - (c) Provide means for recording all telemetered functions on magnetic tape.
5. Ground Digital Computer - The Ground Digital Computer will contain sufficient input-output, memory, logic, arithmetic and control to:
 - (a) Calibrate three accelerometers from data acquired in a minimum of six positions for scale factor and bias.
 - (b) Perform gyro drift test.
6. Ground Support Equipment - The ground support equipment will:
 - (a) Provide necessary power levels and controls.
 - (b) Air conditioning
 - (c) Provide such other support as is necessary to operate the system in ground modes.

APPENDIX 11

REFERENCES

- (1) L. N. Jenks, Monthly Progress Report No. 1, "Specification Design Study for Flight Testing Inertial Guidance Systems - GEM (Guidance Evaluation Missile)," dated 15 December 1961, No. 8640-6001-CU000.
- (2) L. N. Jenks, Monthly Progress Report No. 2, "Specification Design Study for Flight Testing Inertial Guidance Systems - GEM (Guidance Evaluation Missile)," dated 23 January 1962, No. 8640-6006-CU000.
- (3) Jernell, L. S. and Wang, Norman: Investigation of the Static Longitudinal Stability Characteristics of a .067 - Scale Model of a Four-Stage Configuration of the Scout Research Vehicle at Mach Numbers of 2.29, 2.96, 3.96, and 4.65. NASA TN D-554, 1960.
- (4) Robinson, R. B.: Aerodynamic Characteristics in Pitch and Side-slip of a 1/15 Scale Model of the Scout Vehicle at a Mach Number of 2.01, NASA TN D 793, 1961.
- (5) Kelly, T. C.: Transonic Wind-Tunnel Investigation of the Static Longitudinal Aerodynamic Characteristics of Several Configurations of the Scout Vehicle and of a Number of Related Models. NASA TN D-794, 1961.
- (6) Chadwick, G. A.: Static Force Data for the Terminal Guidance Vehicles II and III DTMB Transonic Tunnel. AVCO RAD-SR-61-147, 1961 (Confidential).
- (7) Van Dyke, M. D.; Gordon, H. G.: Supersonic Flow Past a Family of Blunt Axisymmetric Bodies. NASA TR R-1, 1959.