

NOTICE: When government or other drawings, specifications or other data are used for any purpose other than in connection with a definitely related government procurement operation, the U. S. Government thereby incurs no responsibility, nor any obligation whatsoever; and the fact that the Government may have formulated, furnished, or in any way supplied the said drawings, specifications, or other data is not to be regarded by implication or otherwise as in any manner licensing the holder or any other person or corporation, or conveying any rights or permission to manufacture, use or sell any patented invention that may in any way be related thereto.

CATÉGORIE ASTIA 29 6991
AS AD NO.

BUREAU D'ANALYSE ET DE RECHERCHE APPLIQUÉES

US NAVY CONTRACT N.62558 - 2545

FINAL REPORT

1963
RECEIVED

DECEMBER 30, 1962.

"ANALOG STUDY OF IMMERGED PROFILES IN PROXIMITY
OF THE FREE SURFACE WITH A SURIMPOSED LOAD
DISTRIBUTION."

296 991

This research work was supported by the Office
Of Naval Research.

B.A.R.A.

47, AVENUE VICTOR-CRESSON
ISSY-LES-MOULINEAUX
(SEINE)

US NAVY CONTRACT N. 62558 - 2545

FINAL REPORT

DECEMBER 30, 1962.

"ANALOG STUDY OF IMMERSGED PROFILES IN PROXIMITY
OF THE FREE SURFACE WITH A SURIMPOSED LOAD
DISTRIBUTION."

This research work was supported by the Office
Of Naval Research.

1. Theory of the small perturbations for an immersed profile in proximity of the free surface.

1.1. Introduction.

Let us consider a continuous, irrotational, two-dimensional flow limited by a free surface. The fluid is supposed to be incompressible, perfect and heavy. The complex potential of the flow can be written as follows :

$$F(z) = V_0 z + f(z) = \Phi + i\Psi \quad (1.1.)$$

where V_0 represents the velocity of the uniform flow at upstream infinity and $f(z)$ the complex perturbation potential.

We intend to consider the stream function :

$$\Psi = V_0 y + \psi \quad (1.2.)$$

where ψ represents the stream perturbation which is, as Ψ , an harmonic function. This means that the ψ potential meets the equation :

$$\frac{\partial^2 \psi}{\partial x^2} + \frac{\partial^2 \psi}{\partial y^2} = 0 \quad (1.3.)$$

1.2. Generalities on the linear theory of the small perturbations for a flow limited by its free surface.

Let us consider a two-dimensional flow, as defined above, where a thin profile represented by its chord $AF = S$ is placed at a distance f of the static level of the free surface (fig. 1.1.).

The free surface is a stream line of the flow (normal velocity equal to zero). The Bernoulli theorem applied to this line, between the two sections $-\infty$ and $+x$, gives :

$$\frac{p_0}{\rho} + \frac{V_0^2}{2} = \frac{p}{\rho} + \frac{V^2}{2} + gy$$

where p_0 , V_0 are the pressure and the flow velocity at upstream infinity, and p and V the same elements in the x section of the perturbed flow. In the expression (1.4.) we insert the components u , v of the perturbation velocity.

$$\frac{p_0}{\rho} + \frac{V_0^2}{2} = \frac{p}{\rho} + \frac{V_0^2 + 2V_0u + u^2 + v^2}{2} + gy \quad (1.5.)$$

Whence, neglecting the second order terms :

$$p - p_0 = -\rho V_0 u - \rho gy ; \quad (1.6.)$$

at the free surface, the pressure is equal to p_0 , whence the condition :

$$V_0 u = -gy \quad (1.7.)$$

The sliding condition on the profile and at the free surface shows that, there, the normal velocities are equal to zero, this being in accordance with the physical reality (always with respect to the linear theory). It is written :

$$\frac{dy}{dx} = \frac{v}{V_0 + u} \approx \frac{v}{V_0} \quad (1.8.)$$

We shall insert to 1.7. and 1.8. the perturbation stream function, by means of already known relations :

$$u = \frac{\partial \Psi}{\partial y} ; \quad v = - \frac{\partial \Psi}{\partial x} \quad (1.9.)$$

So :

$$V_0 \frac{\partial \Psi}{\partial y} = -gy \quad (1.10.)$$

and,

$$\frac{dy}{dx} = - \frac{\partial \Psi}{\partial x} \frac{1}{V_0} . \quad (1.11.)$$

Taking this last condition projected on to the x's axis and integrating between $-\infty$ and x, we obtain :

$$y_{sl} = - \frac{\Psi}{V_0} = \eta \quad (1.12.)$$

where η will represent the ordinate at the free surface. If we insert (1.12.) in (1.10.) :

$$\frac{\partial \Psi}{\partial y} = \frac{g}{V_0^2} . \quad (1.13.)$$

The sliding condition on the linearized profile in the x's direction, integrated between the leading edge and the abscissa ξ , allows us to obtain :

$$y(\xi) = - \frac{\Psi_{\xi} - \Psi_A}{V_0} \quad (1.14.)$$

To the assumptions which have enabled us to define the (1.12.), (1.13.), (1.14.) conditions, we add the assumption of the linearization of the boundary conditions : these conditions are written in projection and fulfilled on the x's axis. The condition (1.13.) will now be written :

$$-\frac{\partial \Psi}{\partial n} = \frac{g}{V_0^2} \Psi \quad (\vec{n} \text{ normal directed towards the inside of the fluid}) \quad (1.15.)$$

and, by inserting the factor

$$K = \frac{g}{V_0^2} \quad (1.16.)$$

we shall write :

$$-\frac{\partial \Psi}{\partial n} = K \Psi \quad (1.17.)$$

We still have to add another condition which takes into account the characteristics of the flow at upstream of the profile. In this region, there are no waves, while they may appear at downstream of the profile.

1.3. Set-up of the problem.

The solution of the direct problem, i.e. the study of a profile whose characteristics in an indefinite flow are known, when it is located in a flow limited by a free surface, has been envisaged by various authors.

Vladimirov (1) quotes various works permitting to determine the total efforts acting on an immersed profile. The author himself and the people mentioned in his article do not take interest in the details of the flow - distribution of pressures and velocities - though this problem be of a great importance for the study of all the **cavitation phenomena.**

More recent experimental and theoretical researches have tried to clear up this problem. Among the former, let us mention the works of Ausman (3) and Parkin, Perry and Wu (4). From a theoretical point of view, the work of Nishiyama (2) and of Isay (5) presents a great interest.

It is obvious that any solution allowing the determination of the shape of the profile for a distribution of imposed pressure (inverse problem) should be welcome by the engineers in charge of its design. Two works, Nishiyama (6) and Parkin and Peebles (7) deal with this problem. But the former only takes into account the free surface effect. Parkin and Peebles start from the assumption that the profiles in operation are placed at a depth which is equal to twice their chord value, there where the surface effects can be neglected without introducing important errors into the computation.

The utilization of mathematic models, well known in aerodynamics in order to solve these problems, has logically led us to consider the possibility of using the analog computation methods - which have already proved satisfactory in aerodynamics - to find out the numerical solution of this problem. We thus avoid a great number of unsuccessful attempts, especially while dealing with the inverse problem. We consider that the flow generated by a profile is due to the superposition of two effects, the lift effect and the thickness effect. The former is equivalent to a vortex distribution along the projection of the profile, according to the x's axis. The latter corresponds to a distribution of sources and sinks on the same projection. The intensity of the vortices is directly in relation with the local load, while the mass flow of the sources and sinks is related to the thickness law. The local load and the thickness law are the basis of the problem.

From the analog point of view, it appeared that the condition at the free surface was very difficult to represent. We thus have been obliged to modify the approach of the problem in order to obtain an easier representation, by converting the Fourier condition (1.17.) which, under this form, implies the use of negative resistances, into a Dirichlet condition satisfied by the superposition of solutions obtained analytically for a vortex or a source. These free surfaces are such that they always meet the conditions (1.12.) and (1.17.).

The computation process that we are going to adopt in order to solve the inverse problem, presents itself as follows :

- a) Computation of the free surface for the chosen vortices distribution and for a given flow.
- b) Determination of the mean line of the profile before the vortex distribution and the free surface of (a) par.
- c) Analog determination of the free surface for the chosen sinks and sources distribution and for a given flow.
- d) Analog determination of the shape of the profile which corresponds to (c) par.

This settles down the plan to follow in the course of the next paragraphs.

2. Free Surface of the Perturbed Flows.

2.1. Set-up of the problem.

In this section, we shall determine the shape of the free surface generated by a perturbation - vortex or source - immersed in a uniform flow. The calculation is effected by the "image" method (8) where one suppose the existence of a S system of sources and sinks in a fluid which possesses one or several boundaries C . If, when placing a S' system of sources or sinks in the external region of C and permitting the incoming of the fluid in the whole region, we find out that C is a stream line ; the S' system is called the image in C of the S system".

In our particular case, the free surface is a stream line limiting a flow where is placed a vortex or a source at a distance $-f$ from this surface and at $x = 0$. The vortex or image source will then be located at a distance $+f$ from this surface and at $x = 0$. To the equations system thus obtained we shall have to add a certain function permitting to fulfill the condition (1.17.) at the free surface.

2.2. Free Surface for an Immersed Vortex.

The complex potential of a vortex is written :

$$F(z) = i \frac{\Gamma}{2\pi} \log (z - z_0) = \frac{i\Gamma}{2\pi} (\log r + i\theta) \quad (2.1.)$$

$$\text{for } z - z_0 = r e^{i\theta}$$

$$\text{where } \phi = - \frac{\Gamma}{2\pi} \theta \text{ is the velocity potential} \quad (2.2.)$$

$$\text{and } \psi = \frac{\Gamma}{2\pi} \log r \text{ the stream function} \quad (2.3.)$$

A permanent flow limited by a free surface near which is located a vortex, will be defined by its complex potential whose stream function will be written :

$$\psi = V_0 y + \frac{\Gamma}{2\pi} \log r + \psi_1 = V_0 y + \psi \quad (2.4.)$$

The Ψ function is called perturbation stream function. It should fulfill the boundary condition expressed in (1.15.). In this purpose, we shall consider the Ψ function as a result of the complex potentials generated on one hand by the vortex itself, on the other hand by the image vortex and finally by a complementary function χ .

We can thus write :

$$\Psi = \frac{\Gamma}{2\pi} \log r - \frac{\Gamma}{2\pi} \log r_1 + \chi \quad (2.5.)$$

$$\text{or : } \Psi = \frac{\Gamma}{2\pi} \log \frac{r}{r_1} + \chi \quad (2.6.)$$

$$\text{with } r = \sqrt{x^2 + (y+f)^2} \quad \text{and } r_1 = \sqrt{x^2 + (y-f)^2} \quad (2.7.)$$

$$\text{We suppose that } \chi = \int_0^{\infty} \alpha(k) e^{ky} \cos kx \, dk \quad (2.8.)$$

where $\alpha(k)$ is a function of k to determine. Starting from the expressions (2.6.), (2.8.) and from the condition (1.15.), we obtain :

$$\int_0^{\infty} \alpha(k) k e^{ky} \cos kx \, dk + \frac{\Gamma}{2\pi} \left(\frac{y+f}{r^2} - \frac{y-f}{r_1^2} \right) = \quad (2.9.)$$

$$\frac{g}{V_0^2} \left[\int_0^{\infty} \alpha(k) e^{ky} \cos kx \, dk + \frac{\Gamma}{2\pi} \log \frac{r}{r_1} \right]$$

Now, at the free surface, $y = 0$ and $r_1 = r$. The expression (2.9.) becomes :

$$\int_0^{\infty} \alpha(k) \cos kx \, dk + \frac{\Gamma}{\pi} \frac{f}{r^2} = \frac{g}{V_0^2} \int_0^{\infty} \alpha(k) \cos kx \, dk \quad (2.10.)$$

and admitting that :

$$\frac{\Gamma}{\pi} \frac{f}{r^2} = \int_0^{\infty} e^{-kf} \cos kx \, dk \quad (2.11.)$$

we obtain :

$$\int_0^{\infty} \left[\alpha(k) \cos kx \, k + \frac{\Gamma}{\pi} e^{-kf} \cos kx - \frac{g}{V_0^2} \alpha(k) \cos kx \right] dk = 0 \quad (2.12.)$$

Thence the function $\alpha(k)$:

$$\alpha(k) = \frac{\Gamma}{\pi} \frac{e^{-kf}}{(K - k)} \quad (2.13.)$$

with $K = \frac{g}{V_0^2}$.

If this expression of $\alpha(k)$ is inserted in (2.6.), the perturbation stream function can be written :

$$\Psi = \frac{\Gamma}{2\pi} \log \frac{r}{r_1} + \frac{\Gamma}{\pi} \int_0^{\infty} \frac{e^{-kf}}{(K - k)} e^{ky} \cos kx \, dk \quad (2.14.)$$

According to the sliding condition, the free surface is defined by :

$$\eta = - \frac{\Psi}{V_0} \quad (2.15.)$$

From (2.14.) and (2.15.) and taking into account the conditions previously set forth for the free surface, we obtain :

$$\eta = - \frac{\Psi}{V_0} = - \frac{\Gamma}{\pi V_0} \int_0^{\infty} \frac{e^{-kf}}{(K - k)} \cos kx \, dk \quad (2.16.)$$

The integral is undetermined, but if x is positive, its principal value is equal to the real part of the expression (9)

$$i \pi e^{-Kf + iKx} + i \int_0^{\infty} \frac{e^{-imf - mX}}{(im - K)} dm \quad (2.17.)$$

and we have :

$$\eta = - \frac{\Gamma}{V_0} e^{-Kf} \sin Kx - \frac{\Gamma}{V_0 \pi} \int_0^{\infty} \frac{(K \sin mf - m \cos mf) e^{-mx}}{K^2 + m^2} dm \quad (2.18.)$$

The function (2.16.) is an even function in x . For $x < 0$, we shall have :

$$\eta = \frac{\Gamma}{V_0} e^{-Kf} \sin Kx - \frac{\Gamma}{V_0 \pi} \int_0^{\infty} \frac{(K \sin mf - m \cos mf) e^{mx}}{m^2 + K^2} dm \quad (2.18')$$

If we add a system of stationary waves to this solution :

$$\eta_a = - \frac{\Gamma}{V_0} e^{-Kf} \sin Kx \quad (2.19.)$$

in order that, in accordance with the physical reality, the free surface at upstream of the profile has no wave, the expressions (2.18.) and (2.18') become :

$$\left\{ \begin{array}{l} \eta = - 2 \frac{\Gamma}{V_0} e^{-Kf} \sin Kx - \frac{\Gamma}{V_0 \pi} \int_0^{\infty} \frac{(K \sin mf - m \cos mf) e^{-mX}}{K^2 + m^2} dm \\ \quad X \geq 0 \\ \eta = \frac{\Gamma}{V_0 \pi} \int_0^{\infty} \frac{(K \sin mf - m \cos mf) e^{mX}}{K^2 + m^2} dm \\ \quad X < 0 \end{array} \right. \quad (2.20.)$$

which give the solution to be obtained.

2.3. Free surface for an immersed source.

The logical process which leads to the determination of the free surface equations for an immersed source is quite similar to all that has been exposed for a vortex.

The flow around a source in the presence of the free surface is defined by its stream function :

$$\Psi = V_0 y + \frac{Q}{2\pi} \theta + \chi_1 = V_0 y + \Psi \quad (2.21.)$$

The perturbation stream function must fulfill the condition (1.15.). We suppose that Ψ is the total of the potentials resulting on one hand from the source itself, on the other hand from its image, and finally from a complementary function χ .

We suppose that :

$$\chi = \int_0^{\infty} \alpha(k) e^{ky} \sin kx \, dk \quad (2.23.)$$

where $\alpha(k)$ is a function to determine.

The perturbation stream function can then be written :

$$\Psi = \frac{Q}{2\pi} (\theta_1 + \theta_2) + \int_0^{\infty} \alpha(k) e^{ky} \sin kx \, dk \quad (2.24.)$$

The first term of the second member is the imaginary part of the complex function.

$$\frac{Q}{2\pi} \left[\log(z + f) + \log(z - f) \right] \quad (2.25.)$$

Thence :

$$\begin{aligned} \frac{\partial \Psi}{\partial y} &= \frac{\partial}{\partial y} \frac{Q}{2\pi} (\theta_1 + \theta_2) = R \frac{Q}{2\pi} \left[\frac{1}{z+f} + \frac{1}{z-f} \right] \\ &= R \frac{Q}{2\pi} \frac{\cos \theta_1 - i \sin \theta_1}{r_1} + \frac{\cos \theta_2 - i \sin \theta_2}{r_2} \end{aligned} \quad (2.26.)$$

At the free surface, $y = 0$ and $\theta_1 = \theta_2$; $r_1 = r_2$, we have :

$$\frac{\partial}{\partial y} \frac{Q}{2\pi} (\theta_1 + \theta_2) = \frac{Q}{\pi} \frac{x}{r^2} = \frac{Q}{\pi} \int_0^{\infty} e^{-kf} \sin kx \, dk \quad (2.27.)$$

Taking account of the conditions expressed hereabove, we shall replace (2.24.) and (2.27.) in (1.15.) :

$$\frac{Q}{\pi} \int_0^{\infty} e^{-kf} \sin kx \, dk + \int_0^{\infty} \alpha(k) k \sin kx \, dk = \frac{g}{V_0^2} \int_0^{\infty} \alpha(k) \sin kx \, dk \quad (2.28.)$$

from which we can obtain the function $\alpha(k)$

$$\alpha(k) = -\frac{Q}{\pi} \frac{e^{-kf}}{k-K} \quad \text{where } K = \frac{g}{V_0^2} \quad (2.29.)$$

At the free surface, the expression (2.24.) will be written :

$$\Psi = - \int_0^{\infty} \frac{e^{-kf}}{\pi} \frac{\sin kx \, dk}{(k-K)} \quad (2.30.)$$

The principal value of the integral is equal to the imaginary part of (2.17.). We shall thus obtain :

$$\eta = \frac{Q}{V_0} e^{-kf} \cos Kx - \frac{Q}{V_0 \pi} \int_0^{\infty} \frac{(K \cos mf + m \sin mf) e^{-m \cdot x}}{m^2 + K^2} dm \quad (2.31.)$$

for $x > 0$

η is an odd function in x , for $x < 0$, we shall write :

$$\eta = -\frac{Q}{V_0} e^{-Kf} \cos Kx + \frac{Q}{V_0 \pi} \int_0^{\infty} \frac{(K \cos mf + m \sin mf) e^{m \cdot x}}{m^2 + K^2} dm \quad (2.31.')$$

To cancel the waves at upstream infinity, we must add a series of waves of the following shape :

$$\eta_{\alpha} = \frac{Q}{V_0} e^{-Kf} \cos Kx \quad (2.32.)$$

It comes for $x > 0$ and $x < 0$:

$$\left\{ \begin{array}{l} \eta = \frac{2Q}{V_0} e^{-Kf} \cos Kx - \frac{Q}{\pi V_0} \int_0^{\infty} \frac{(K \cos mf + m \sin mf) e^{-m \cdot x}}{m^2 + K^2} dm \\ x > 0 \\ \eta = \frac{Q}{\pi V_0} \int_0^{\infty} \frac{(K \cos mf + m \sin mf) e^{m \cdot x}}{m^2 + K^2} dm \\ x < 0 \end{array} \right. \quad (2.33.)$$

2.3.1. Starting from the expressions we have just determined, we shall obtain the expression of the free surface, due to an immersed doublet :

$$\eta_D = \eta_{\text{source at point } \Delta x} + \eta_{\text{sinks at point } 0} = \frac{d\eta}{d\lambda} \Delta \lambda$$

$$\eta_D = -\frac{Q}{V_0} \Delta \lambda e^{-kf} K \sin Kx + \frac{Q}{V_0 \pi} \Delta x \int_0^{\infty} \frac{(mK \cos mf + m^2 \sin mf) e^{-m \cdot x}}{m^2 + K^2} dm \quad (2.34.)$$

$\eta \cdot \frac{V_0}{Q}$

TABLE 2.1.

$\frac{X}{P}$ \ / \ $\frac{f}{\lambda}$	$\frac{1}{4}$	$\frac{1}{8}$	$\frac{1}{20}$
- 5,0		+ 0,0700	+ 0,1198
- 4,5		+ 0,0800	+ 0,1448
- 4,0		+ 0,0900	+ 0,1734
- 3,5	+ 0,0500	+ 0,1020	+ 0,2021
- 3,0	+ 0,0670	+ 0,1170	+ 0,2307
- 2,5	+ 0,0830	+ 0,1400	+ 0,2657
- 2,0	+ 0,1020	+ 0,1700	+ 0,3103
- 1,5	+ 0,1250	+ 0,2110	+ 0,3676
- 1,0	+ 0,1500	+ 0,2670	+ 0,4453
- 0,5	+ 0,1750	+ 0,3560	+ 0,5649
- 0,4	+ 0,1820	+ 0,3750	+ 0,5978
- 0,3	+ 0,1880	+ 0,3970	+ 0,6286
- 0,2	+ 0,1960	+ 0,4180	+ 0,6627
- 0,1	+ 0,2040	+ 0,4380	+ 0,6965
0,00	+ 0,2080	+ 0,4520	+ 0,7305
0,1	+ 0,2090	+ 0,4630	+ 0,7638
0,2	+ 0,2000	+ 0,4740	+ 0,7959
0,3	+ 0,1820	+ 0,4810	+ 0,8259
0,4	+ 0,1540	+ 0,4850	+ 0,8517
0,5	+ 0,1190	+ 0,4780	+ 0,8781
1,0	- 0,150	+ 0,3720	+ 0,9441
1,5	- 0,419	+ 0,1350	+ 0,9341
2,0	- 0,518	- 0,170	+ 0,8716
2,5	- 0,377	- 0,486	+ 0,7674
3,0	- 0,067	- 0,756	+ 0,6280
3,5	+ 0,2440	- 0,936	+ 0,4612
4,0	+ 0,381	- 0,9940	+ 0,2781
4,5	+ 0,270	- 0,9140	+ 0,0937
5,0	0,0000	- 0,7090	+ 0,1198
5,5		- 0,4060	- 0,3233
6,0		- 0,050	- 0,5213

TABLE 2.2.

$\frac{\lambda}{F}$ \ / \ $\frac{x}{F}$	4	8	20	50	100
-10.0				+ 0,0720	+ 0,1630
- 9.0				+ 0,0810	+ 0,1760
- 8.0				+ 0,0940	+ 0,1960
- 7.0				+ 0,1080	+ 0,2200
- 6.0				+ 0,1270	+ 0,2470
- 5.0				+ 0,1480	+ 0,2820
- 4.5			+ 0,0032	+ 0,1620	+ 0,3010
- 4.0			+ 0,0223	+ 0,1790	+ 0,3260
- 3.5			+ 0,0414	+ 0,1960	+ 0,3520
- 3.0			+ 0,0611	+ 0,2230	+ 0,3830
- 2.5			+ 0,0789	+ 0,2460	+ 0,4220
- 2.0		- 0,0035	+ 0,0978	+ 0,2810	+ 0,4630
- 1.5	- 0,0144	- 0,0110	+ 0,1152	+ 0,3190	+ 0,5110
- 1.0	- 0,0254	- 0,0280	+ 0,1260	+ 0,3620	+ 0,5730
- 0.5	- 0,0522	- 0,0780	+ 0,1222	+ 0,3940	+ 0,6230
- 0.4	- 0,1100	- 0,0960	+ 0,1155	+ 0,3990	+ 0,6320
- 0.3	- 0,1240	- 0,1180	+ 0,1057	+ 0,3940	+ 0,6370
- 0.2	- 0,1430	- 0,1430	+ 0,0933	+ 0,3910	+ 0,6400
- 0.1	- 0,1675	- 0,1750	+ 0,0764	+ 0,3870	+ 0,6450
0.0	- 0,1990	- 0,2140	+ 0,0509	+ 0,3830	+ 0,6480
0.1	- 0,2310	- 0,2470	+ 0,0305	+ 0,3645	+ 0,6340
0.2	- 0,2641	- 0,2860	+ 0,0015	+ 0,3470	+ 0,6180
0.3	- 0,2960	- 0,3320	+ 0,0318	+ 0,3290	+ 0,6010
0.4	- 0,3220	- 0,3790	+ 0,0676	+ 0,3110	+ 0,5850
0.5	- 0,3680	- 0,4280	+ 0,1063	+ 0,2830	+ 0,5650
0.5	- 0,4040				

$\frac{\lambda}{F}$ \ / \ $\frac{x}{F}$	4	8	20	50	100
1.0	-0,4682	-0,6760	-0,3255	+0,1420	+0,4550
1.5	-0,3194	-0,8570	-0,5481	-0,0110	+0,3350
2.0	-0,0144	-0,9190	-0,7600	-0,1560	+0,2280
2.5	-0,2835	-0,8460	-0,9542	-0,2990	+0,1290
3.0		-0,6480	-1,1208	-0,4240	+0,0320
3.5		-0,3500	-1,2603	-0,5540	-0,0570
4.0		0,0000	-1,3671	-0,6690	-0,1420
4.5			-1,4398	-0,7820	-0,2230
5.0			-1,4610	-0,8870	-0,2980
6.0			-1,3894	-1,0810	-0,4400
7.0				-1,2520	-0,5800
8.0				-1,3950	-0,7090
9.0				-1,5110	-0,8310
10.0				-1,6050	-0,9410
11.0				-1,6680	-1,0460
12.0				-1,7030	-1,1470
13.0					-1,2420
14.0					-1,3290
15.0					-1,4110
16.0					-1,4840
17.0					-1,5520
18.0					-1,6120

Surface libre pour une source
Free surface for a source

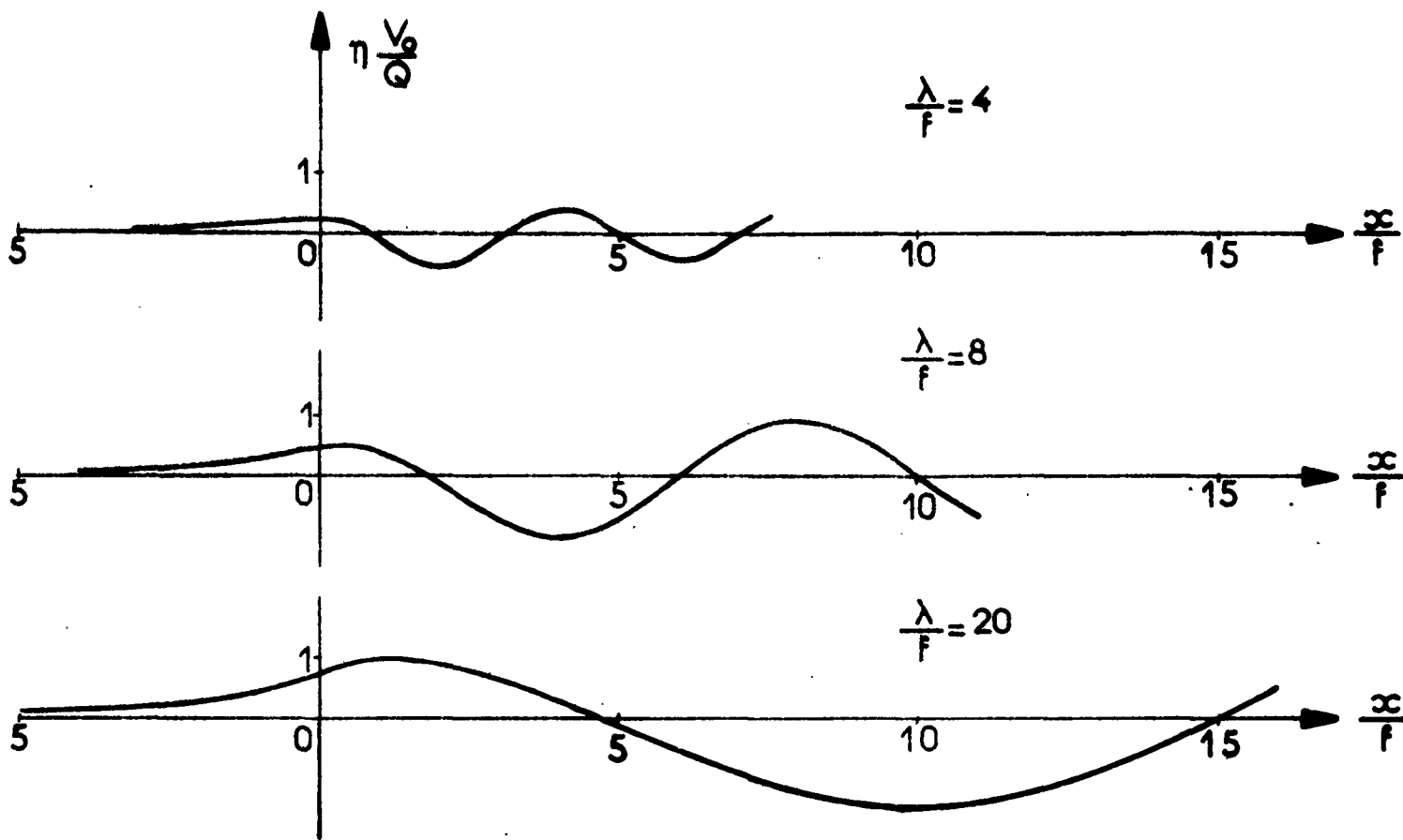
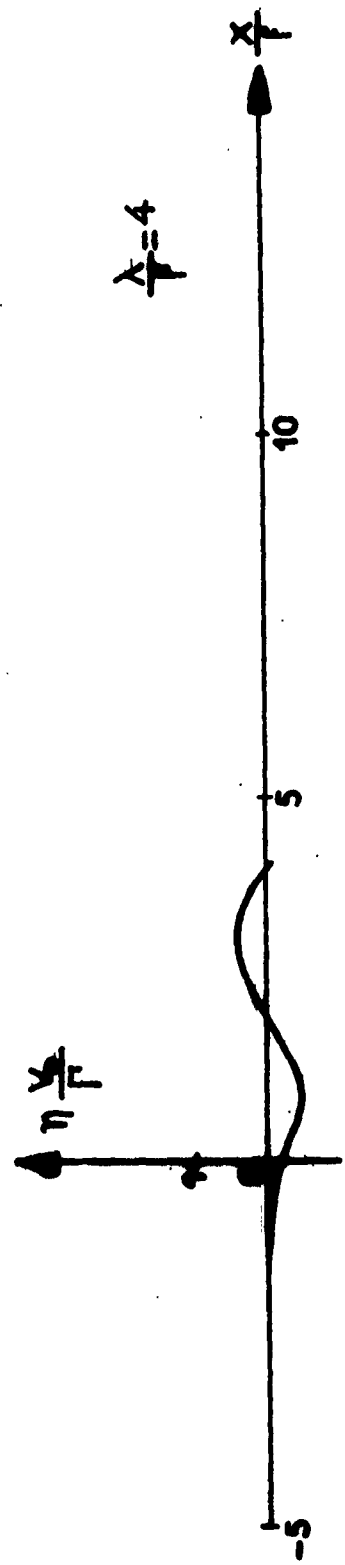

Fig. 2.1

Fig: 2 . 2

SURFACE LIBRE POUR UN TOURBILLON

Free surface for a vortex



$$\Delta = 0$$

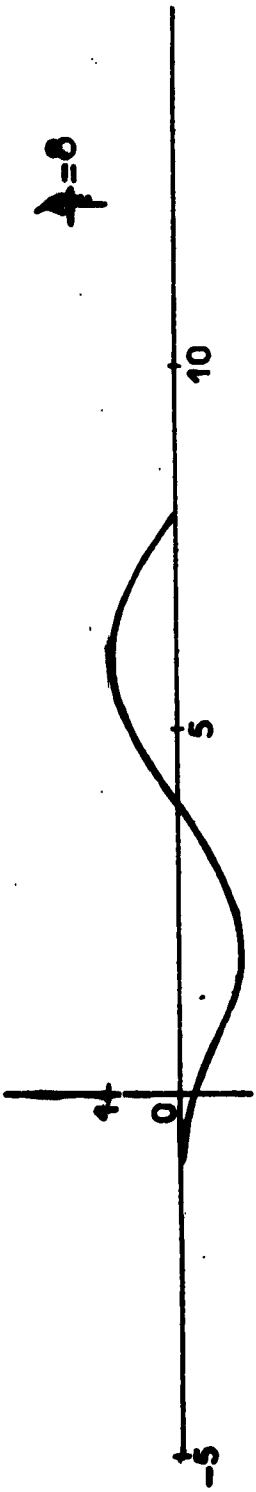

$$\Delta = 20$$

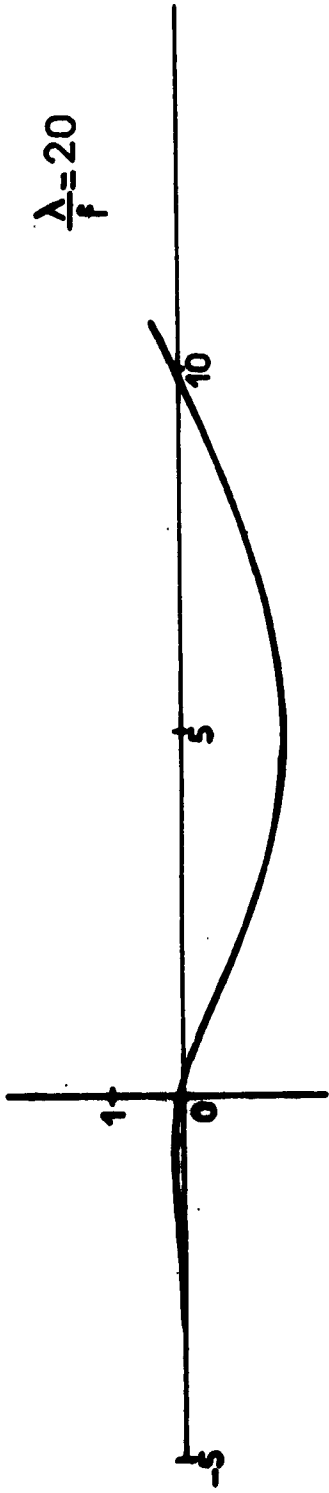

$$\Delta = 50$$

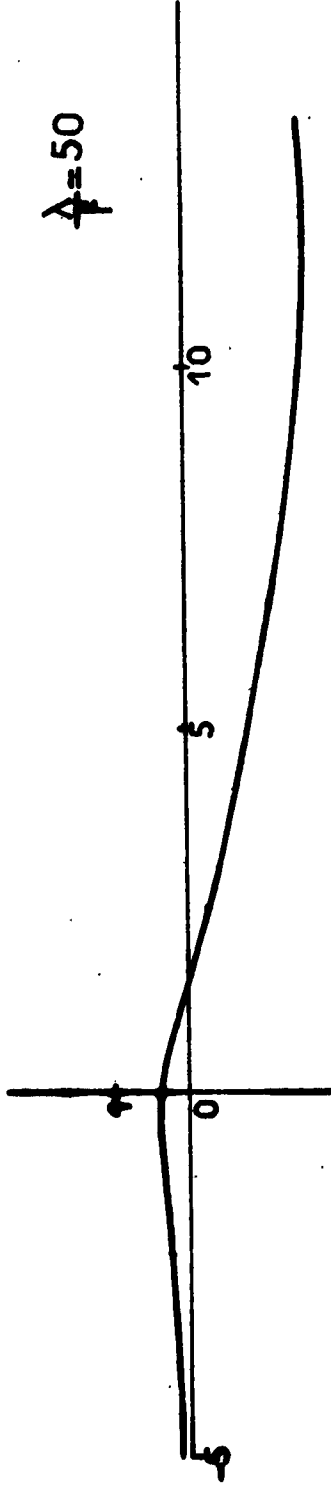

$$\Delta = 100$$

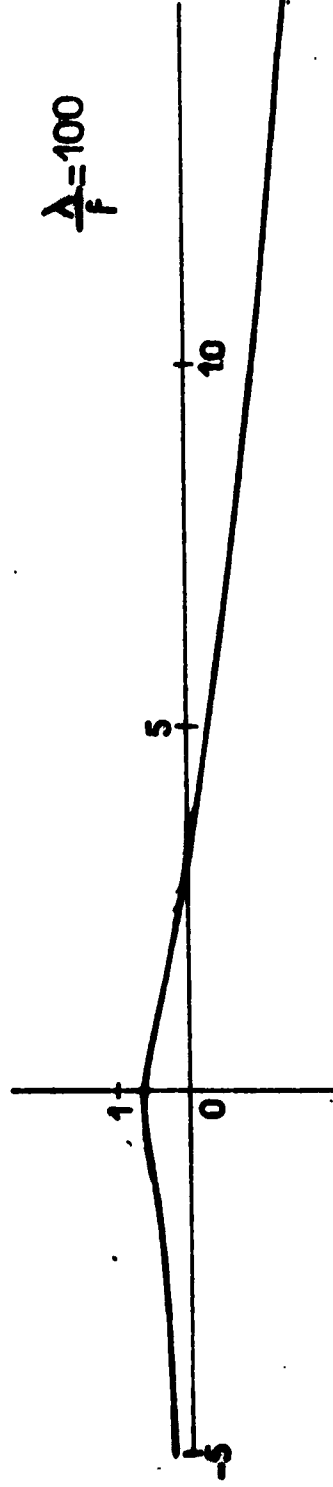

And, considering that these complex potentials can be written in the following way :

$$\frac{q \Delta \chi}{2\pi z} = \frac{V_0 b^2}{z} \quad (2.35.)$$

and

$$2\pi b^2 = \frac{q \Delta \chi}{V_0} \quad (2.36.)$$

and then :

$$\int_0^{\infty} e^{-m\chi} \sin mf \, dm = \frac{f}{r^2} \quad (2.37.)$$

The expression (2.34.) becomes :

$$\begin{aligned} \eta_D = 2\pi b^2 K e^{-Kf} \sin Kx + 2b^2 \int_0^{\infty} \frac{m^2 + K^2}{m^2 + K^2} \sin mfe^{-m\chi} \, dm + \\ + 2b^2 \int_0^{\infty} \left(\frac{-K^2 \sin mf + Km \cos mf}{m^2 + K^2} \right) e^{-m\chi} \, dm \end{aligned} \quad (2.38.)$$

where

$$\eta_D = 2b^2 \frac{f}{r^2} - 2\pi b^2 K e^{-Kf} \sin Kx - 2b^2 K \int_0^{\infty} \frac{(K \sin mf - K m \cos mf) e^{-m\chi}}{m^2 + K^2} \, dm$$

for $\chi > 0$ and $\chi < 0$ (2.39.)

$$\begin{aligned} \eta_D &= \frac{q \Delta \chi}{V_0 \pi} \int_0^{\infty} \frac{(mK \cos mf + m^2 \sin mf) e^{m\chi}}{m^2 + K^2} \, dm = \\ &= 2b^2 \int_0^{\infty} \frac{m^2 + K^2}{m^2 + K^2} e^{-m\chi} \sin mf + 2b^2 \int_0^{\infty} \frac{(-K^2 \sin mf + Km \cos mf) e^{m\chi}}{m^2 + K^2} \, dm = \\ &= 2b^2 \frac{f}{r^2} - 2b^2 K \int_0^{\infty} \frac{(K \sin mf - m \cos mf) e^{m\chi}}{m^2 + K^2} \, dm \end{aligned} \quad (2.39')$$

Both equations are similar to those given by Lamb (9) for the case of an immersed cylinder.

2.4. Numerical Calculations.

The main difficulty to apply the formulae we have just established, consists in calculating the integral terms of formulae (2.20.) and (2.33.) . With an arithmetic computer ^o , we have determined the values of these integrals for various values of the parameter $\frac{\lambda}{f}$!

From these values, we have easily computed the shape of the free surface of a flow perturbed by a source or a vortex for various values of the parameter $\frac{f}{\lambda}$. The tables 2.1. and 2.2. and the diagrams 2.1. and 2.2. give the numerical values and the aspect of these surfaces.

^o The calculations have been effected by the Laboratoire de Calcul Numérique de l'Institut Blaise Pascal.

3. Analog Determination of the camber effect of the mean line of an immersed profile submitted to an imposed pressure.

3.1. Definition.

The profile having a chord S and an infinite span is represented by its projection on the x 's axis at a depth $y = -f$ starting from the static level of the free surface coinciding with the x 's axis. The y 's axis divides the profile into two equal parts.

The free surface of the flow will be characterized by its wave length Λ at downstream infinity. The flow will be characterized by the ratios $\frac{\Lambda}{f}$ and $\frac{f}{S}$. The Froude number, with respect to the depth or to the chord, can be deduced as a function of $\frac{\Lambda}{f}$ and $\frac{f}{S}$:

$$Kf = \frac{g}{V_0^2} f = \frac{2\pi}{\Lambda} f \quad (3.1.)$$

and

$$Ff = \frac{V_0}{\sqrt{gf}} = \sqrt{\frac{1}{2\pi} \frac{\Lambda}{f}} \quad (3.2.)$$

where K is the argument of the trigonometric function in (2.20.) and (2.33.), and V_0 the velocity of the uniform flow.

3.2. Set-up of the problem and chosen pressure law :

Dealing with the inverse problem permits the determination of the shape of the mean line of a profile for a lower-upper surface pressure difference distributed on the chord, so as to avoid the infinite overvelocities at the leading edge. We know that, in this case, the chord of the mean line is placed at a given ideal angle of attack. The lift coefficient C_L of the profile will therefore be the "adaptation" C_L .

The adopted load coefficient distribution is that of the mean line NACA 65⁽¹⁰⁾. We can write :

$$\Delta C_p = C_L \frac{\gamma S}{r} = C_L \frac{4}{\pi} \sqrt{1 - 4 \left(\frac{\xi}{S} \right)^2} - \frac{S}{2} \angle \xi \angle + \frac{S}{2} \quad (3.3.)$$

where γ represents the vortex density along the chord. In a $\Delta \xi$ interval, the vortex density γ makes appear a vortex which we shall call $\Delta \Gamma_\xi$, the value of which is :

$$\frac{\Delta \Gamma_\xi}{r} = \frac{4}{\pi} \sqrt{1 - 4 \left(\frac{\xi}{S} \right)^2} \Delta \left(\frac{\xi}{S} \right) \quad (3.4.)$$

In an indefinite fluid, the mean line corresponding to this vortex distribution is given by the expression :

$$\frac{\gamma \cdot 2}{S C_L} = \frac{1}{2 \pi} \sqrt{1 - 4 \left(\frac{\xi}{S} \right)^2} - \frac{S}{2} \angle \xi \angle \frac{S}{2} \quad (3.5.)$$

Figure 3.1. gives us the shape of functions (3.4.) and (3.5.).

3.3. Boundary conditions and formulae.

a) On the segment representing the profile, the boundary condition belongs to the Neumann type. Replacing $\Delta \Gamma_\xi$ by

$$(u^+ - u^-) \Delta \xi = \left(\frac{\partial \psi^+}{\partial y} - \frac{\partial \psi^-}{\partial y} \right) \Delta \xi$$

and taking into account the sign of the normal, it can be written :

$$\left(\psi_n^+ + \psi_n^- \right) = \frac{4 \Gamma}{\pi S} \sqrt{1 - 4 \left(\frac{\xi}{S} \right)^2} \quad (3.6.)$$

b) When replacing the profile by N vortices located along its projection, the geometrical shape of the free surface will be considered as the superposition of the effect of each punctual vortex ; the contribution due to the vortex of $\Delta \Gamma \xi_n$ intensity and located at point $x = \xi_n, y = -f$ is $\eta^*(x, \xi_n) \frac{\Delta \Gamma \xi_n}{V_0}$.

According to (2.20), we have :

$$\left\{ \begin{array}{l} \eta^*(x, \xi_n) = -2e^{-Kf} \sin K(x - \xi_n) \frac{1}{\pi} \int_0^{\infty} \frac{(K \sin mf - m \cos mf) e^{-m(x - \xi_n)} dm}{m^2 + K^2} \quad x > 0 \\ \eta^*(x, \xi_n) = \frac{-1}{\pi} \int_0^{\infty} \frac{(K \sin mf - m \cos mf) e^{m(x - \xi_n)} dm}{m^2 + K^2} \quad x < 0 \end{array} \right. \quad (3.7.)$$

The free surface will therefore be :

$$\eta(x) = \sum_{n=1}^{n=N} \eta^*(x, \xi_n) \frac{\Delta \Gamma \xi_n}{V_0} \quad (3.8.)$$

And, taking into account (1.12.)

$$\frac{\Psi_x}{\rho} = -\frac{V_0 \eta_x}{\rho} = -\sum_{n=1}^{n=N} \eta^*(x, \xi_n) \frac{\Delta \Gamma \xi_n}{\rho} \quad (3.9.)$$

$\frac{\Psi_x}{\rho}$ representing the values of the potentials to be set at the free surface.

c) For $x = -\infty$, the perturbation potential is equal to zero, therefore :

$$\Psi(-\infty, y) = 0$$

d) For a dot rather far from the profile, the only term which remains in the expression (3.7.) is :

$$\eta^*(x, \xi_n) = -2 e^{-Kf} \sin K(x - \xi_n).$$

For the whole symmetrical lot of vortices, we obtain, after operating :

$$\frac{\Psi_x}{\Gamma} = 2 e^{-Kf} \sin Kx \sum_{n=1}^{\frac{N}{2}} \frac{\Delta \Gamma \xi_n}{\Gamma} \cdot \cos K \xi_n$$

If we take a maximum or a minimum of this wave, i.e. an abscissa $X = (2n + 1) \frac{\Delta}{4}$, the vertical component of the perturbation velocity

is equal to zero, therefore :

$$\frac{\partial \Psi(x, y)}{\partial x} = 0$$

e) For $y = -\infty$, we suppose that the flow is not perturbed ; we shall have :

$$\Psi(x, -\infty) = 0$$

3.3.1. We shall consider the Ψ function as the sum of two functions Ψ_1 and Ψ_2 determined by the following boundary conditions :

Function Ψ_1

a) At the free surface

$$\Psi_1(x, 0) = 0$$

b) On the profile

$$\Psi_{1n}^{+1} + \Psi_{1n}^{-1} = \frac{4\pi^2}{11S} \sqrt{1 - 4\left(\frac{Y_0}{S}\right)^2}$$

c) for $x = -\infty$

$$\Psi_1(-\infty, y) = 0$$

d) for $x = \infty$

$$\Psi_1(\infty, y) = 0$$

e) for $y = -\infty$

$$\Psi_1(x, \infty) = 0$$

Function Ψ_2

a')

$$\frac{\Psi_2(x, 0)}{r^n} = \sum_{n=0}^{n=N} P_n(x, \xi_n) \frac{\Delta r^n}{r^n}$$

b')

$$\Psi_{2n}^{+1} + \Psi_{2n}^{-1} = 0$$

c')

$$\Psi_2(-\infty, y) = 0$$

d') For $x = (2n+1)\frac{\lambda}{L}$ $n = 0, 1, 2, \dots, n$

$$\frac{\partial \Psi_2}{\partial x} = 0$$

e')

$$\Psi_2(x, -\infty) = 0$$

The measurement of the potentials Ψ_1 and Ψ_2 on the electrodes of the plate allows to determine, as we shall see further on, the shape of the mean line of the profile for each pair of parameters $\frac{f}{S}$ and $\frac{f}{\lambda}$.

Fig. 3.2. shows the boundary limits exposed hereabove.

3.3.2. Physical interpretation of Ψ_1 and Ψ_2 .

The Ψ_1 function superposed to a uniform flow represents a flow perturbed by an immersed profile (either a mean line or a non lifting thick profile), the free surface of which, according to the assumption, remains rigid. As a consequence, the perturbation function Ψ_1 at the free surface is equal to zero.

On the other hand, the Ψ_2 function superposed to a uniform flow represents a flow from which the profile has been taken off, but whose free surface shows the same shape as if the profile was still in the flow.

The image of the total flow is obtained by superimposing the fields of the stream lines created by the two above mentioned flows. Figure 3.3. represents the three quoted flows.

3.4. Analog representation and realization of the experiments.

In order to represent an important part of the study field of Ψ , the electrical potential representing Ψ is studied in a rheoelectrical set-up made up of an ordinary tank (tank z) and of an other tank (tank Z) representing, in a mathematical inversion, the outside part of the first one (11). The two tanks are limited by cylindrical surfaces paved with electrodes, connected by pairs one to the other, so as to establish the same potential on each homologous dot of the two surfaces. The power of the inversion transformation is given by the product of the radius of each circle :

$$P = oa \times o'a' = 2925 \text{ cm}^2.$$

At the axis center of the tank Z, we put half a clover of electrodes made up of three cylinders having a 45 mm diameter and tangent one to the another. Each branch represents one of the physical limits of the field. This set-up permits the representation of a region included between $-650 \text{ cm} \angle x \angle +650 \text{ cm}$.

The profile is made up of a plate of plexiglass (3 mm thick, and 20 cm long) bearing 1 cm wide electrodes on both faces. The electrodes are connected two by two so as to fulfill the condition :

$$\psi_n^+ = \psi_n^- \quad (3.10.)$$

We shall therefore obtain :

$$\psi^+ = \psi^- \quad (3.11.)$$

The feeding of the electrodes of the plate is effected by the large resistance method (12) utilized to represent the Neumann condition.

The free surface of the flow is represented in the tank z by a plexiglass plate paved all along with 2 cm electrodes. In the tank Z, the part of the surface representing the flow at the upstream part of the hydrofoil is covered with a continuous electrode. When necessary, it is possible to take this electrode off, and to carry on the experiment with discontinuous electrodes. The downstream part is paved with 1,5 cm electrodes. The potential setting at the free surface is effected by the mean of a couple of one thousand tapes divider bridges mounted symmetrically. The zero value is obtained by the mean of a transformer T permitting to inject, between the two zero marks of the one thousand tapes divider bridges, an electrical current having a direction opposite to the current direction through the leads connecting the bridges. This intensity is regulated by a potentiometer mounted as a rheostat.

3.4.1. Representation of the function Ψ_1 . (Figure 3.4.)

In the displacement, the flow is not perturbed upstream and downstream, condition 3.3.1. c and d. Therefore, the arcs of circles d'c' and f'c', figure 3.4., must be covered with a continuous electrode connected to the zero of the measurement bridge. At the free surface, the imposed condition is 3.3.1. a, the electrodes a0b, a'd' and c'b' are also given a zero value. At a depth important enough, the condition 3.3.1. is fulfilled by a continuous electrode on e'f' connected to zero.

The condition 3.3.1. b on the profile is fulfilled by the mean of a large resistance set-up. Let us consider (fig. 3.4.a) two electrodes connected one to the other and fed by a potential - 100 through a resistance having a R value. The intensity given by the electrodes will be :

$$\begin{aligned} \Psi_{1n}^{+'} + \Psi_{1n}^{-'} &= \frac{1}{\sigma \xi h} (i_1 + i_2) = \frac{1}{\sigma \xi h} I = \frac{1}{\sigma \xi h} \frac{\Psi_{1n} - \bar{\Psi}}{R} \\ &= \frac{\Gamma}{S} \frac{4}{\pi} \sqrt{1 - 4\left(\frac{\xi n}{S}\right)^2} = \frac{\Gamma}{S} f\left(\frac{\xi n}{S}\right) \quad (3.12.) \end{aligned}$$

where σ = conductivity of the water ($\Omega^{-1} \text{ cm}^{-1}$)
 ξ = width of the electrodes (cm)
 h = height of water (cm).

If $\bar{\Psi}$ is determined as above mentioned, to the value - 100 and if we give the resistances R rather high values, it is always possible to measure a potential included between 0 and - 5. Now, let us make R inversely proportional to the values of $f\left(\frac{\xi n}{S}\right)$, then :

$$\xi R = \frac{R}{f\left(\frac{\xi n}{S}\right)} \quad (3.13.)$$

The condition (3.12.) will be written, if we suppose

$$\Psi - \bar{\Psi} \approx 100, \quad (3.14.)$$

and, if we change R by its value obtained in (3.13.) :

$$\frac{1}{\sigma h} \frac{f(\frac{\xi_n}{S})}{K} 100 = \frac{\Gamma}{S} f(\frac{\xi_n}{S}) \quad (3.15.)$$

This relation, where all the participating factors are known, permits to compute the value of .

$$\Gamma = \frac{100S}{\sigma hK} \quad (3.16.)$$

The value of K is obtained by making several step by step tests until we verify that $0 < \Psi < 5$. Practically, two tests are enough.

If we measure the potentials Ψ on each electrode of the plate, we can write, according to (1.12.)

$$\Psi_{1 \xi_n} - \Psi_{1A} = -V_{0y} \xi_n \quad (3.17.)$$

To obtain a non-dimensional result, we divide this expression by Γ

$$\frac{\Psi_{1 \xi_n} - \Psi_{1A}}{\Gamma} = -\frac{V_0}{\Gamma} y_1 \xi_n \quad (3.18.)$$

and in multiplying numerator and denominator of the second member by the chord S, and then in taking into account the relation :

$$\frac{V_0 S}{\Gamma} = \frac{2}{C_L} \quad (3.19.)$$

We get :

$$\frac{\Delta \Psi_1 \xi_n}{r} = \frac{\Psi_1 \xi_n - \Psi_{1A}}{r} = \frac{y_1 \xi_n}{s} \cdot \frac{2}{c_L} \quad (3.20.)$$

3.4.2. Representation of the function Ψ_2 .

In the displacement Ψ_2 , the electrodes at the free surface on aob, a'd' and c'b' are connected to the potentials calculated according to (3.9.) (condition 3.3.1. a'). At upstream infinity, the flow is not perturbed (condition 3.3.1. c') we can thus impose the zero potential on d'e' as well as on e'd', under the condition that the profile be far from this region. At a rather important depth, the condition 3.3.1. is valid and we impose the zero potential on e'f'. Finally, on f'e', according to the condition 3.3.1. d', the surface will have to be insulating.

On the plate, the condition 3.3.1. b' is fulfilled if the electrodes are not fed. On these electrodes, we shall measure an electrical potential proportional to $\Psi_2 \xi_n$ and we can write :

$$\frac{\Delta \Psi_2 \xi_n}{r} = \frac{\Psi_2 \xi_n - \Psi_{2A}}{r} = - \frac{y_2 \xi_n}{s} \cdot \frac{2}{c_L} \quad (3.21.)$$

3.4.3. Composition of Ψ_1 and Ψ_2 .

The dimensionless variables obtained by the formulae (3.20.) and (3.21.) give, to an additional constant, the value of the mean line data at the abscissa ξ_1 , for each of the displacements Ψ_1 and Ψ_2 . The total of the expressions (3.20.) and (3.21.) allows to obtain the shape of the mean line in a flow equal to the sum of Ψ_1 and Ψ_2 . Therefore :

$$\frac{\Delta \Psi_1 \xi_n}{\Gamma} + \frac{\Delta \Psi_2 \xi_n}{\Gamma} = \frac{\Delta \Psi_1 \xi_n \Delta \Psi_2 \xi_n}{\Gamma} = -\frac{2}{C_L} \left[\frac{y_1 \xi_n}{s} + \frac{y_2 \xi_n}{s} \right] = -\frac{2}{C_L} \frac{y \xi_n}{s} \quad (3.22.)$$

3.5. Experiments and results.

We have realized two series of experiments for two different ratios of f/s . These ratios have been chosen for the following reasons ; for depths superior to a chord, the influence of the free surface seems rather low, while if the depth decreases by more than half a chord, we are more and more leaving the practical cases. For each ratio of f/s , we have realized seven experiments for different f/Λ ratios : ∞ , $1/4$, $1/8$, $1/20$, $1/50$, $1/100$ and 0.

The two extreme cases ∞ and 0 are of interest as they correspond to two flows whose physical characteristics are also extreme : infinitely heavy and non-heavy fluid.

Fig. 3.5. shows the shape of the mean line which bears a pressure law imposed for those two boundary cases and for various ratios of f/s . It is of interest to point out the lift coefficient variation of a NACA 65 mean line, the angle of incidence of which is equal to zero, with respect to the lift coefficient in an indefinite fluid. Fig. 3.6. shows the unfavorable effect of a non rigid free surface on the lift. Fig. 3.7. and 3.8. show the aspect of the mean lines obtained through the analog computation, for various ratios of $\frac{f}{\Lambda}$.

Distribution tourbillonnaire de la ligne moyenne (NACA 65)
Vortex distribution of the mean line (NACA 65)

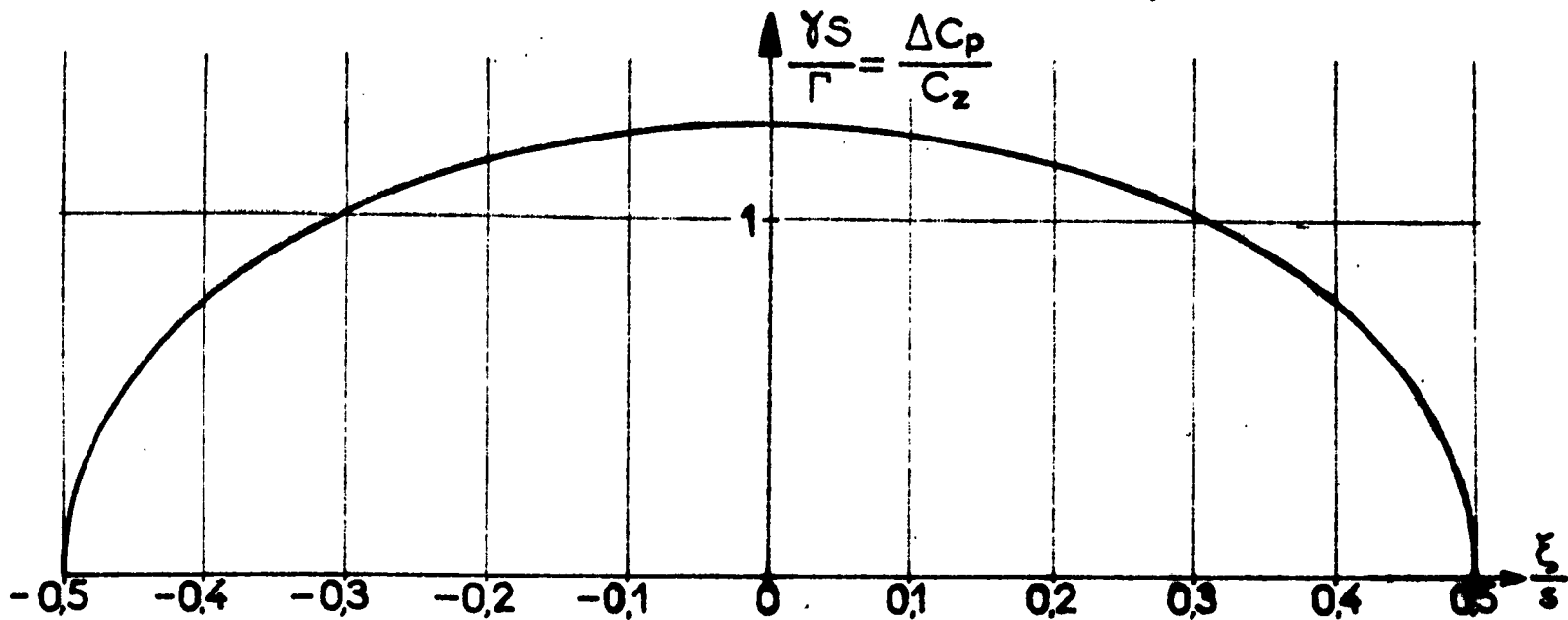

Ligne moyenne NACA 65
Mean line NACA 65

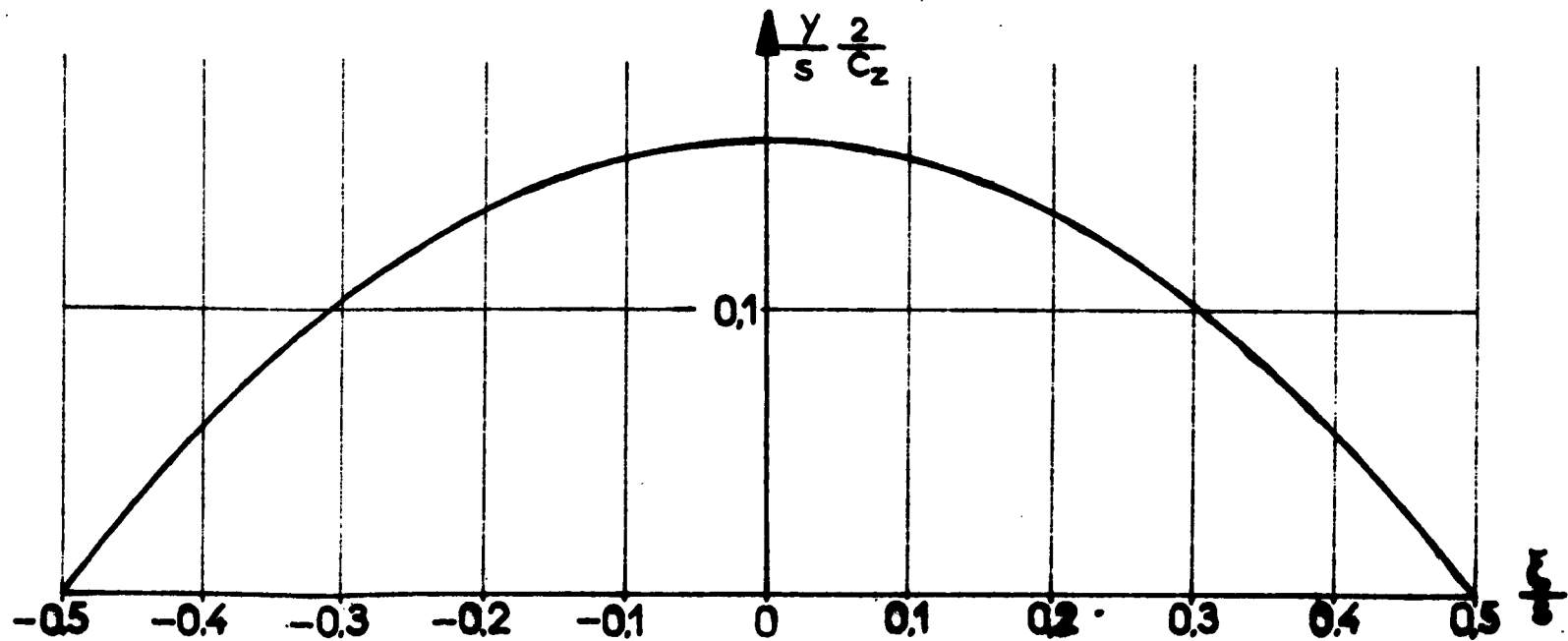

Fig: 3.1

Conditions limites de la représentation analogique
ligne moyenne.

Boundary conditions of the analog representation - mean line

Function Ψ_1

$$\Psi_1 = 0$$

$$\Psi_{1n}^{+'} + \Psi_{1n}^{-'} = \frac{\Gamma}{s} \frac{4}{\pi} \sqrt{1 - 4\left(\frac{\xi_n}{s}\right)^2}$$

$$x = -\infty$$

$$\Psi_1 = 0$$

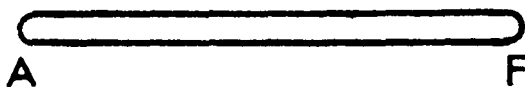

$$x = +\infty$$

$$\Psi_2 = 0$$

$$y = -\infty \quad \Psi_1 = 0$$

Function Ψ_2

$$\frac{\Psi_2}{\Gamma} = \sum_{n=1}^{n=N} \eta(x, \xi_n) \frac{\Delta \Gamma \xi_n}{\Gamma}$$

$$\Psi_{2n}^{+'} + \Psi_{2n}^{-'} = 0$$

$$x = -\infty$$

$$\Psi_2 = 0$$

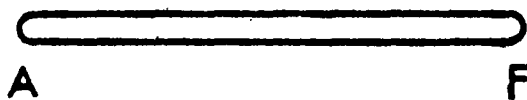

$$x = (2n+1)\frac{\Lambda}{4}$$

$$\Psi_{2\bar{x}} = 0$$

$$y = -\infty \quad \Psi_2 = 0$$

Fig: 3.2

Interprétation physique de Ψ_1 et Ψ_2
Physical interpretation of Ψ_1 and Ψ_2

function $\Psi_1 = V_0 y + \Psi_1$

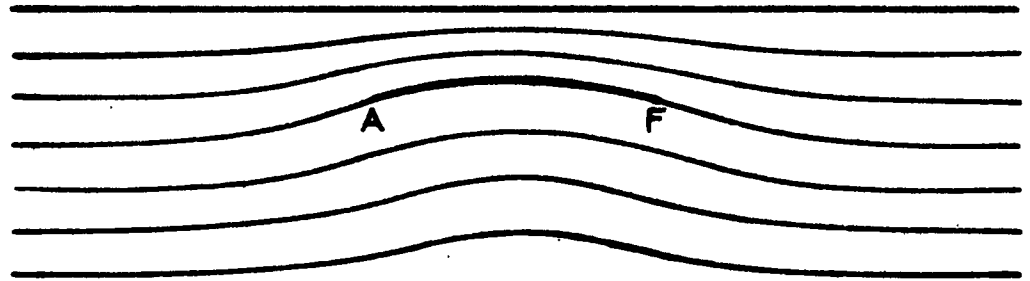

function $\Psi_2 = V_0 y + \Psi_2$

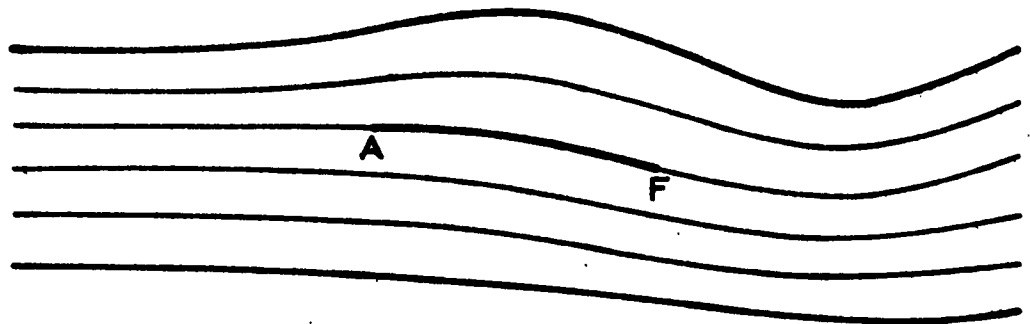

function $\Psi = V_0 y + \Psi_1 + \Psi_2$

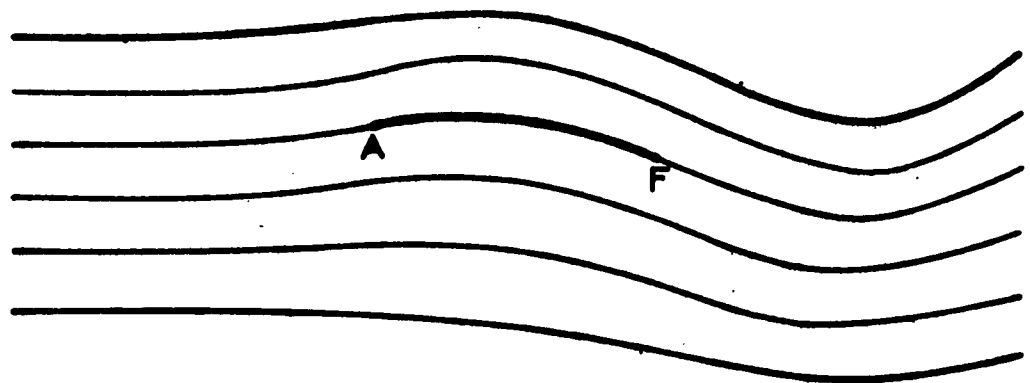
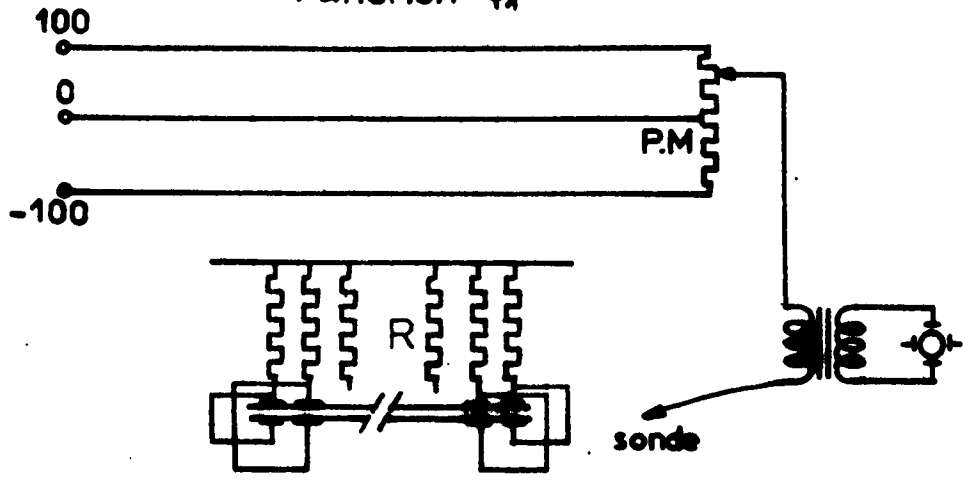

Fig: 3.3

CAMBRURE
Function ψ_1

CAMBER



Function ψ_2

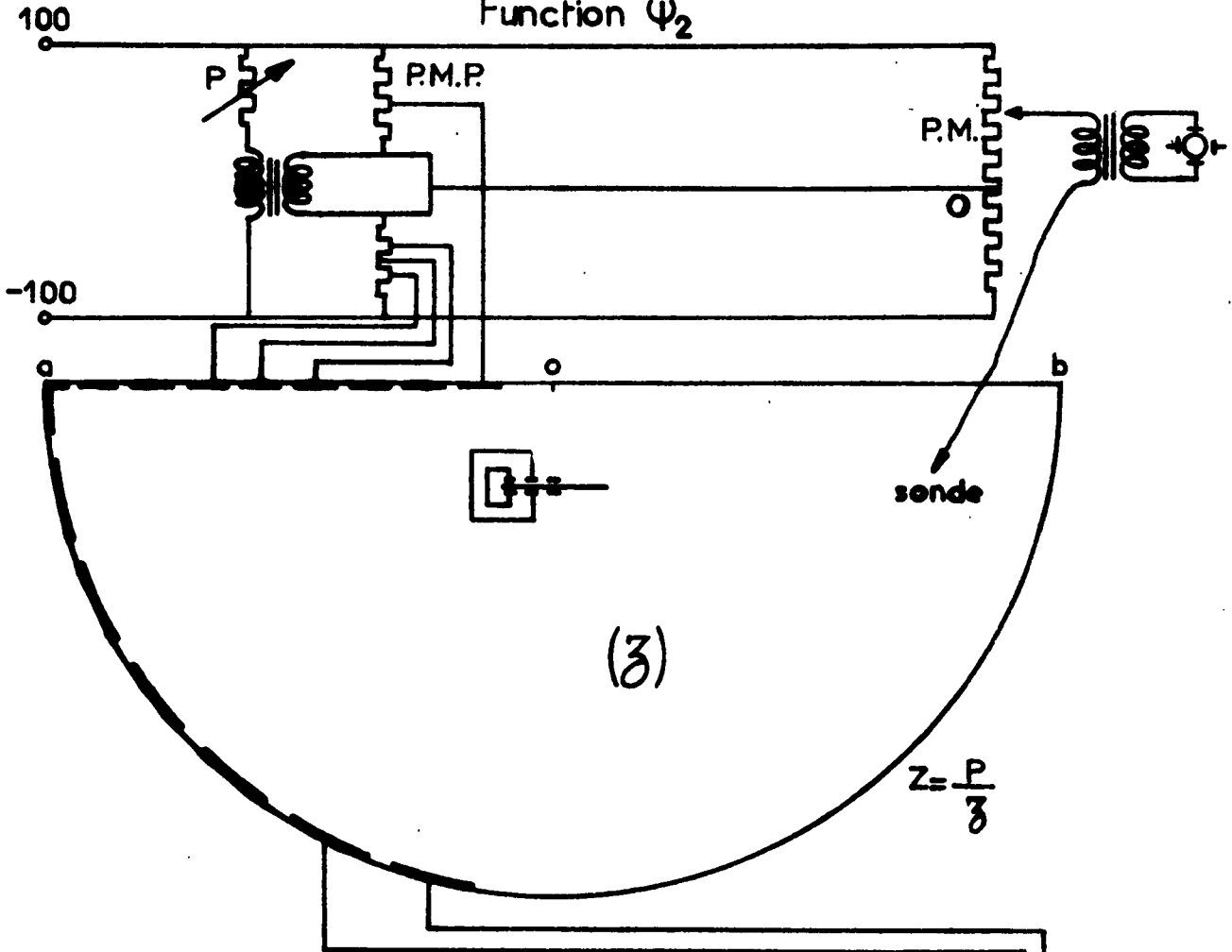

(z)

$$z = \frac{P}{\delta}$$

Fig: 3.4

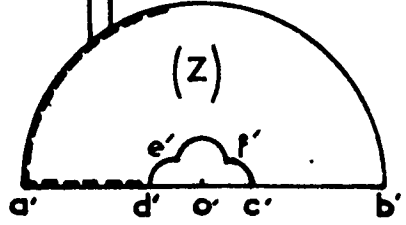

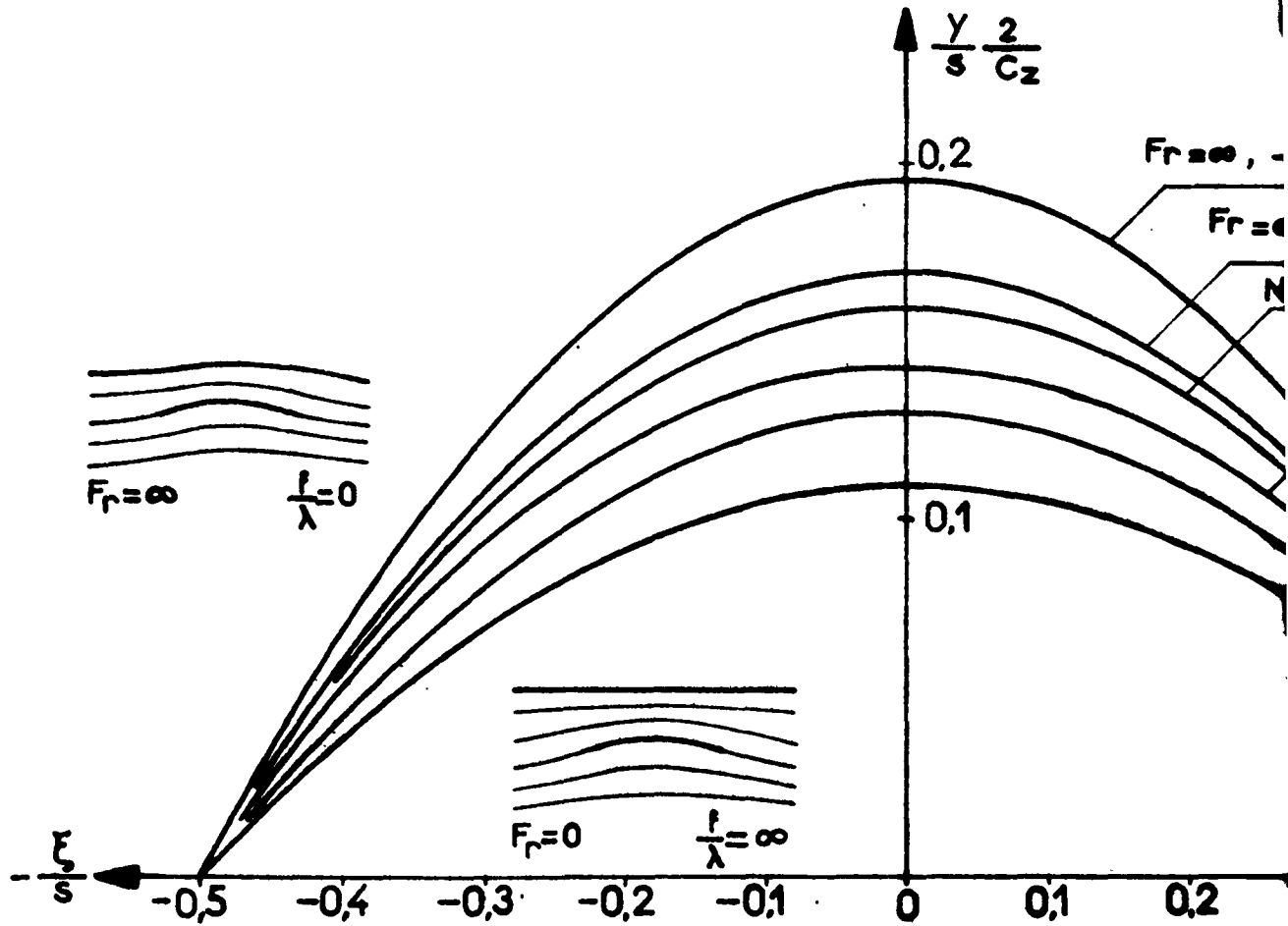

Fig:35

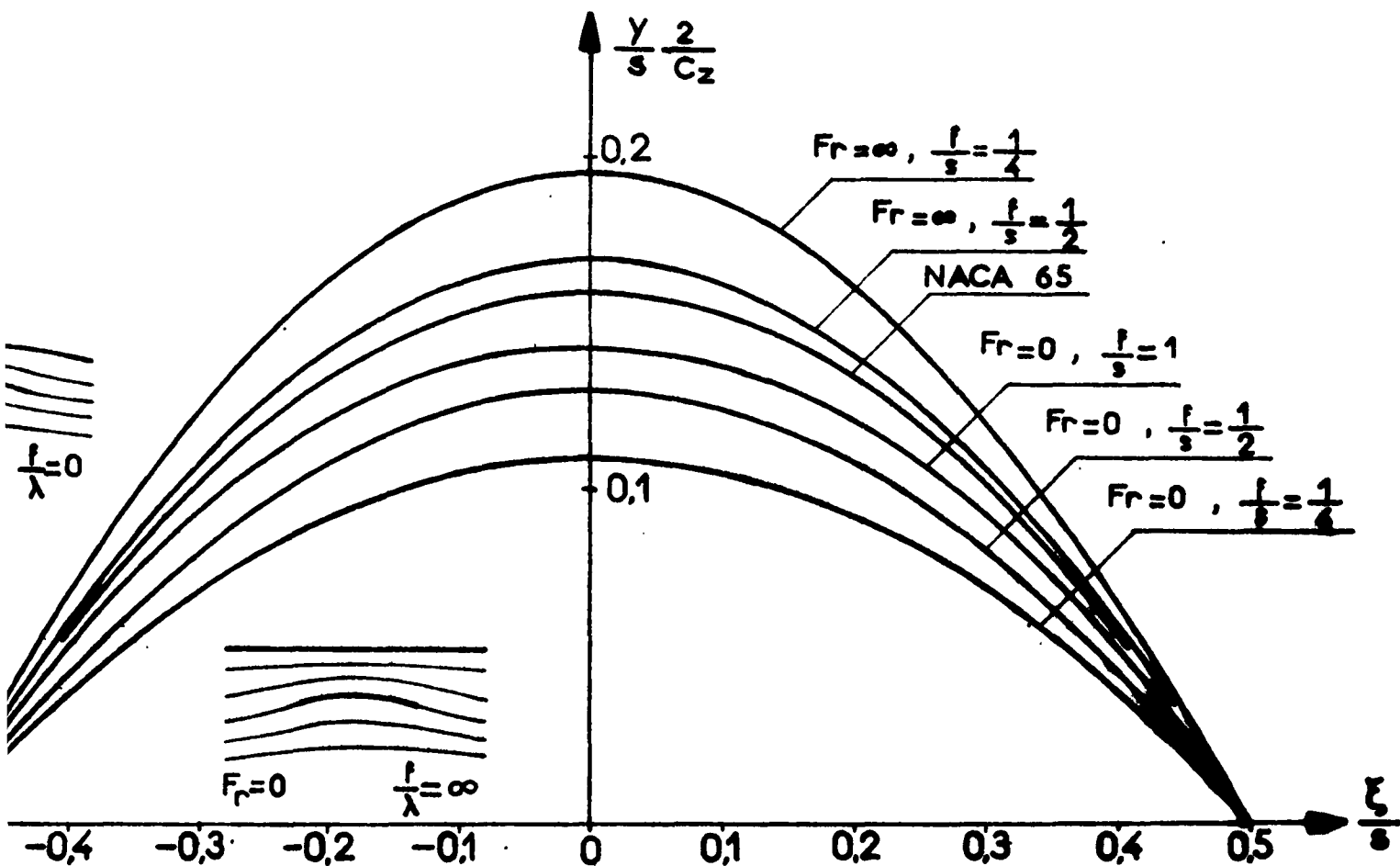

Fig:35

Variation du coefficient de portance pour un profil
près de la surface libre

Lift coefficient variation for a profile near the free surface

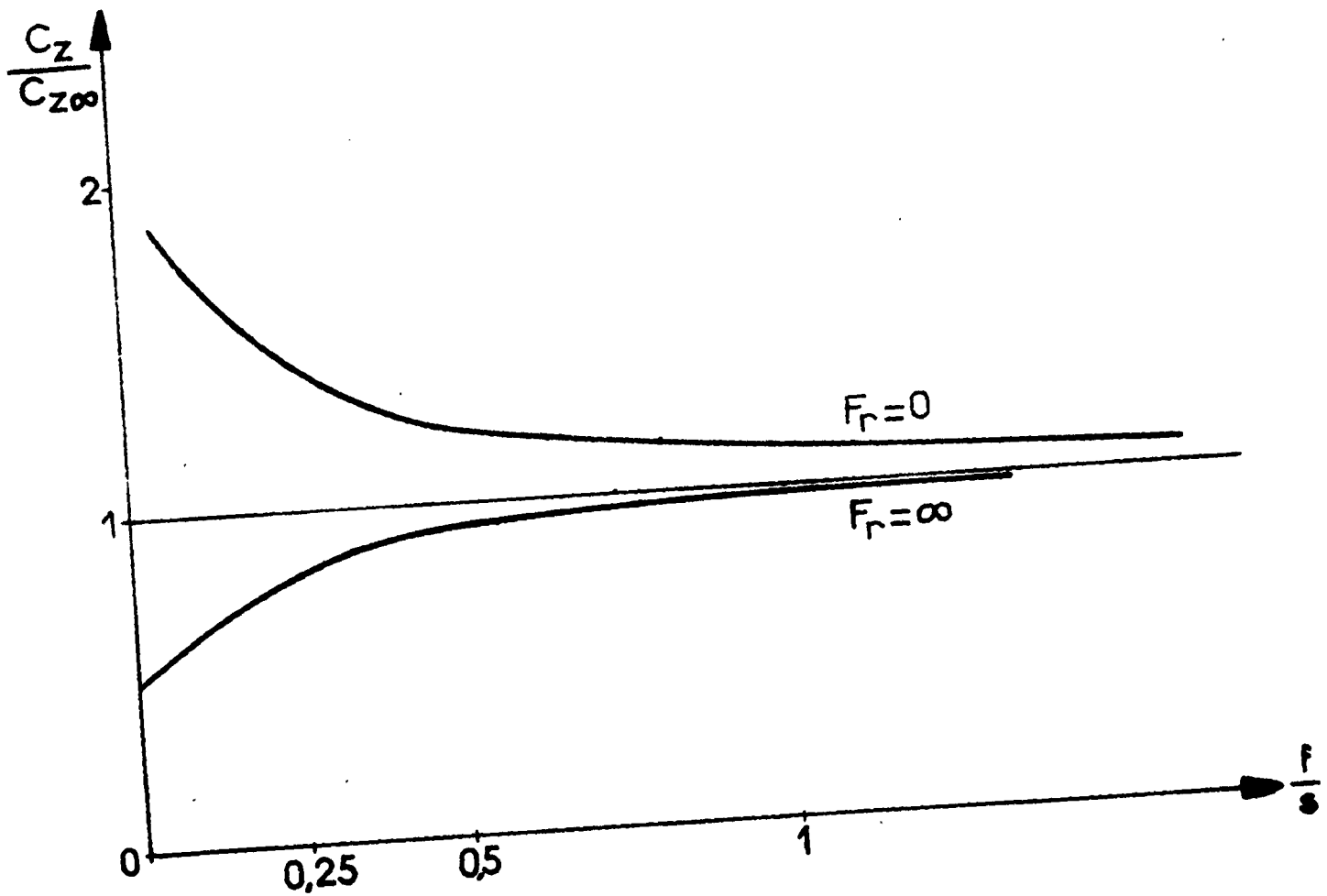
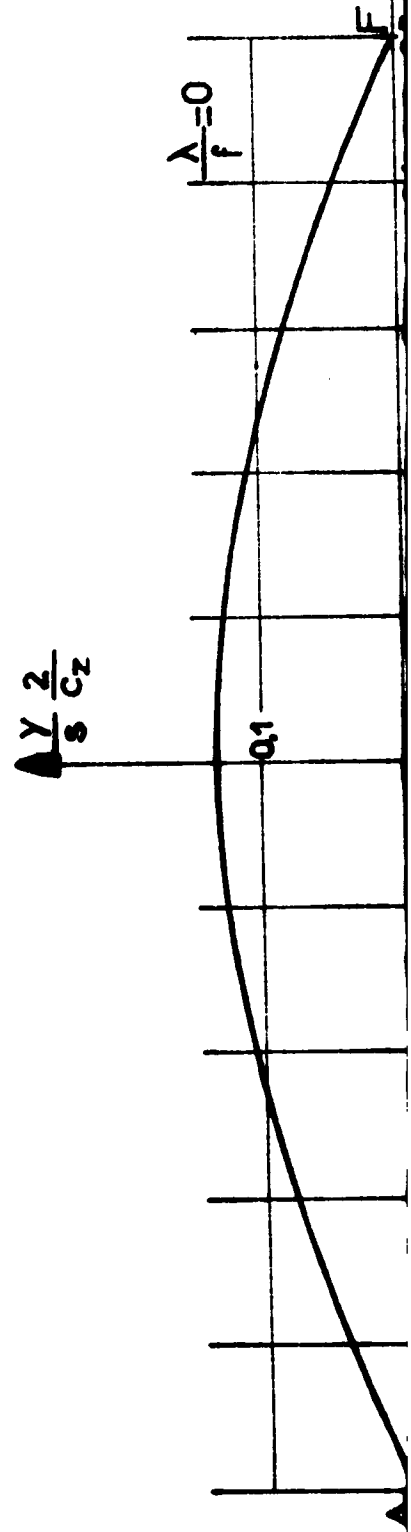
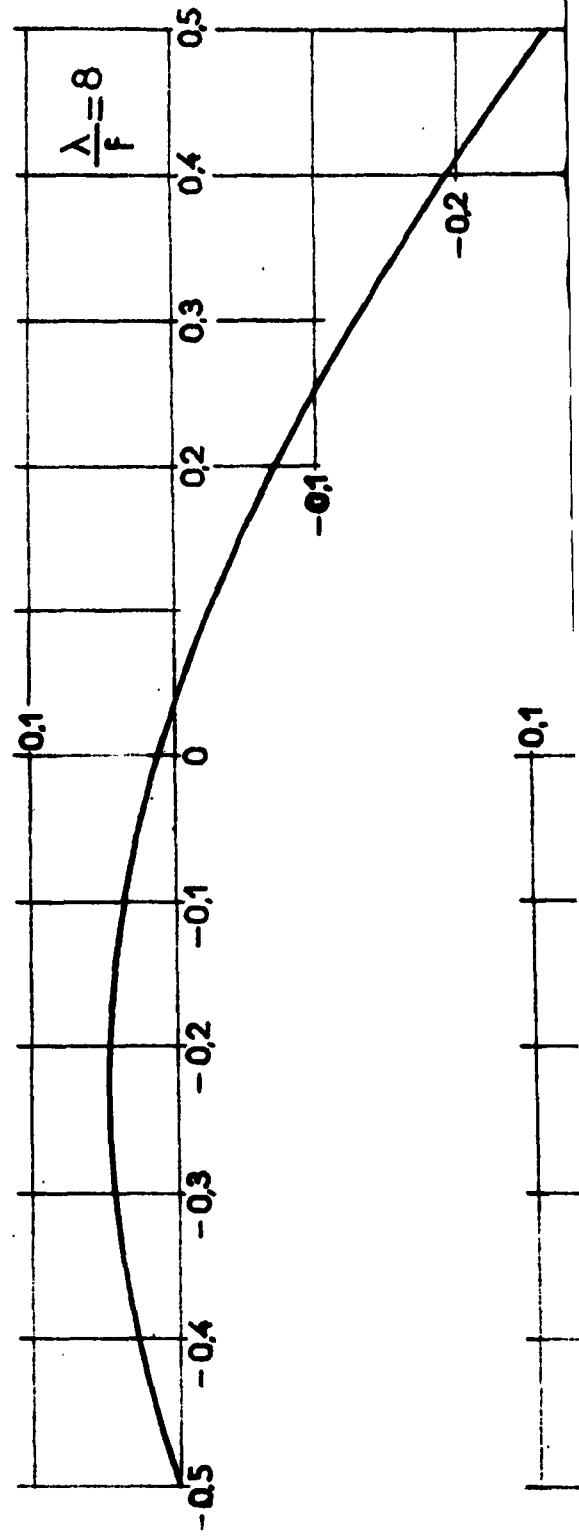
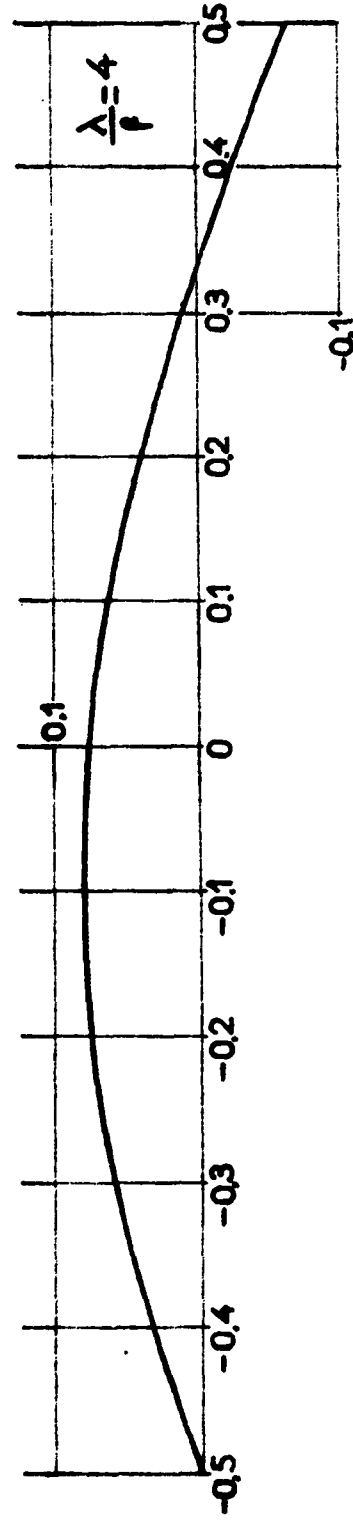
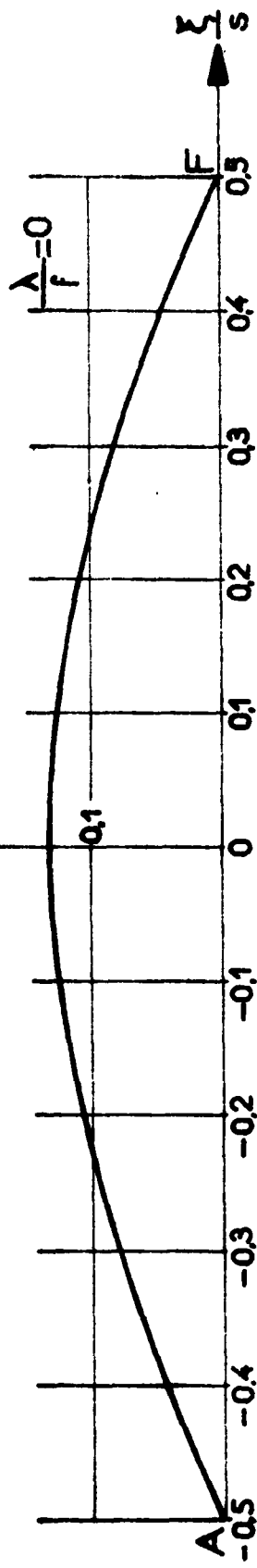

Fig: 3.6

Fig: 3.7

LIGNES MOYENNES POUR $f = \frac{s}{2}$
Mean lines for $f = \frac{s}{2}$





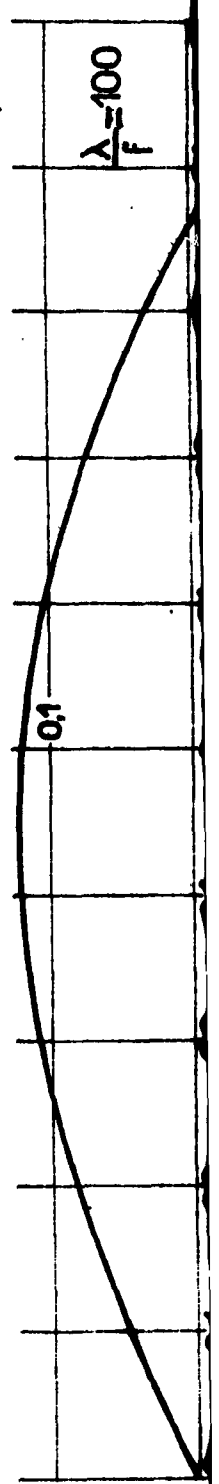
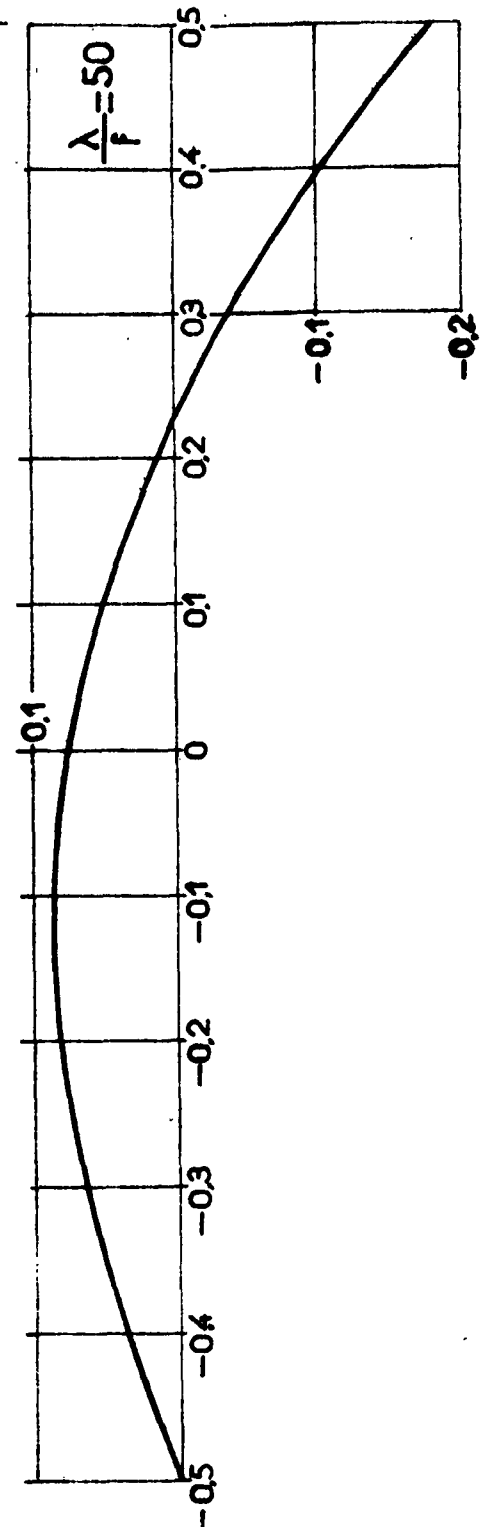
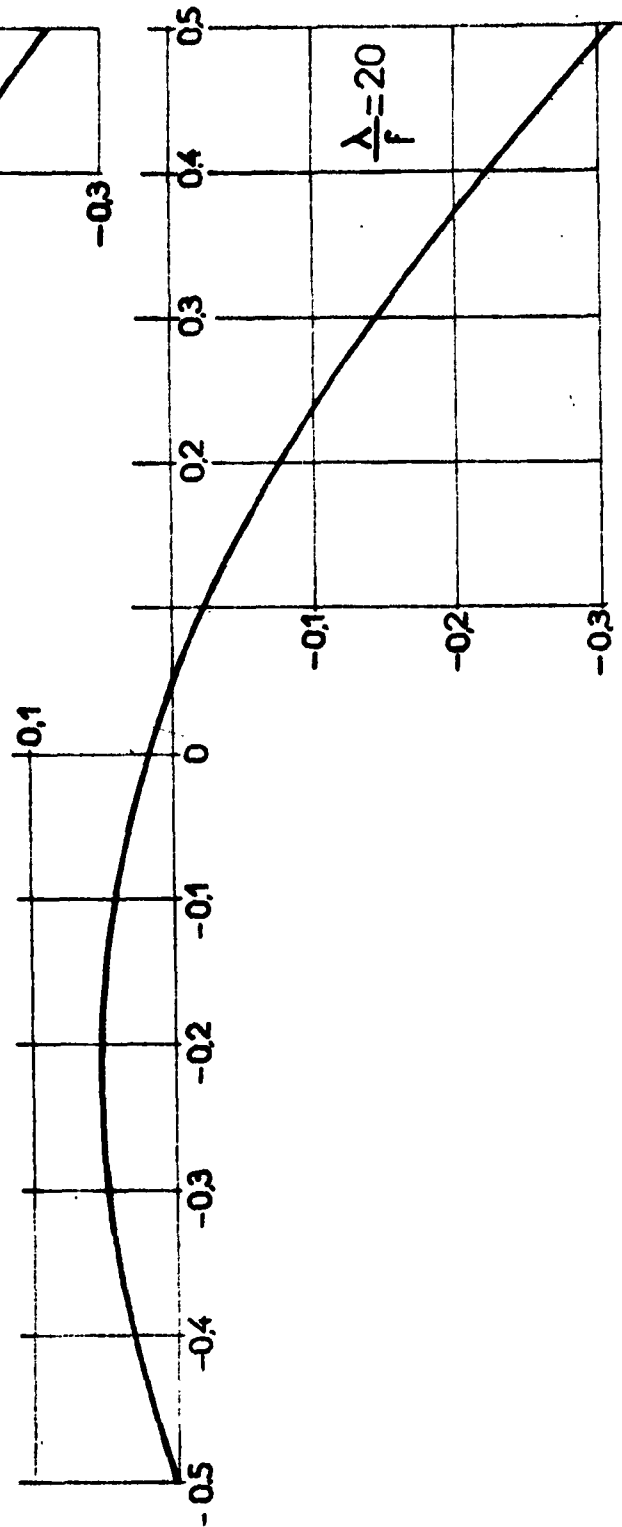
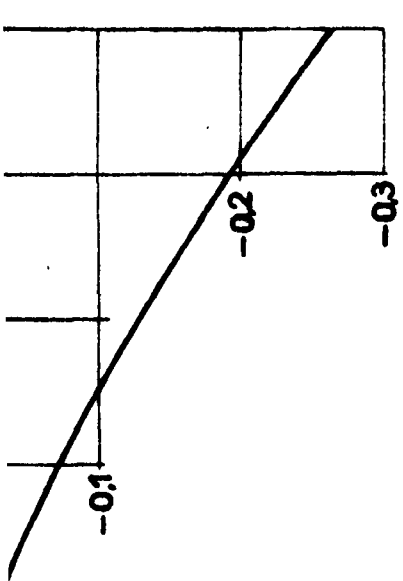

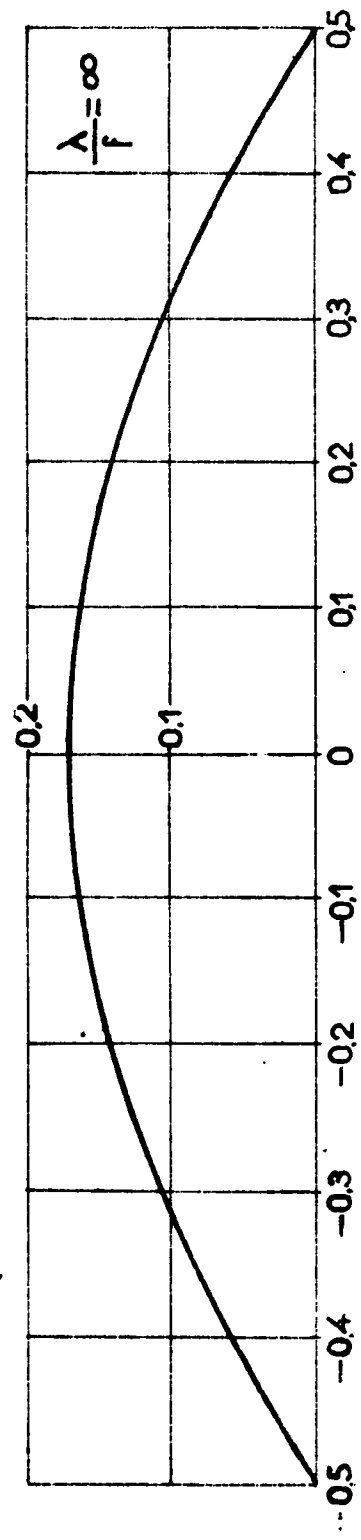
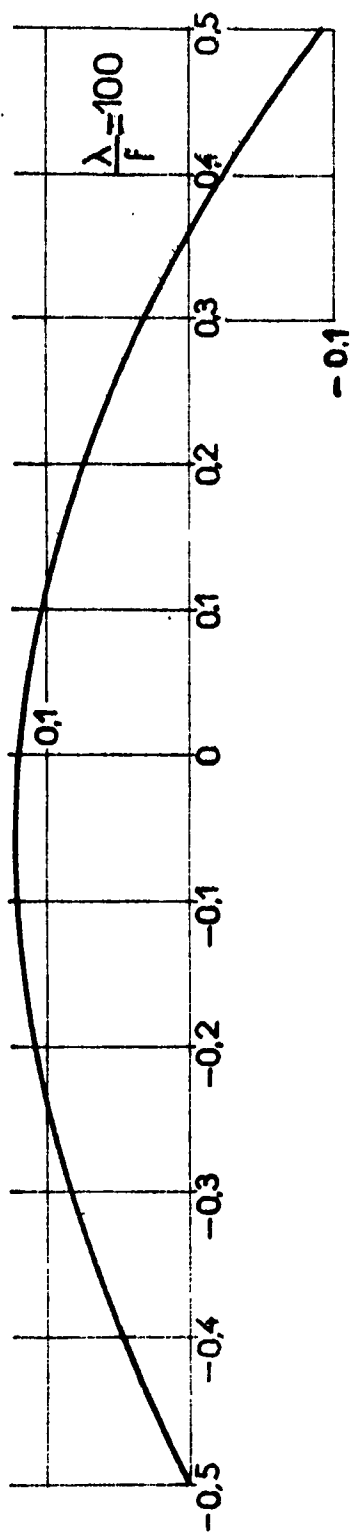
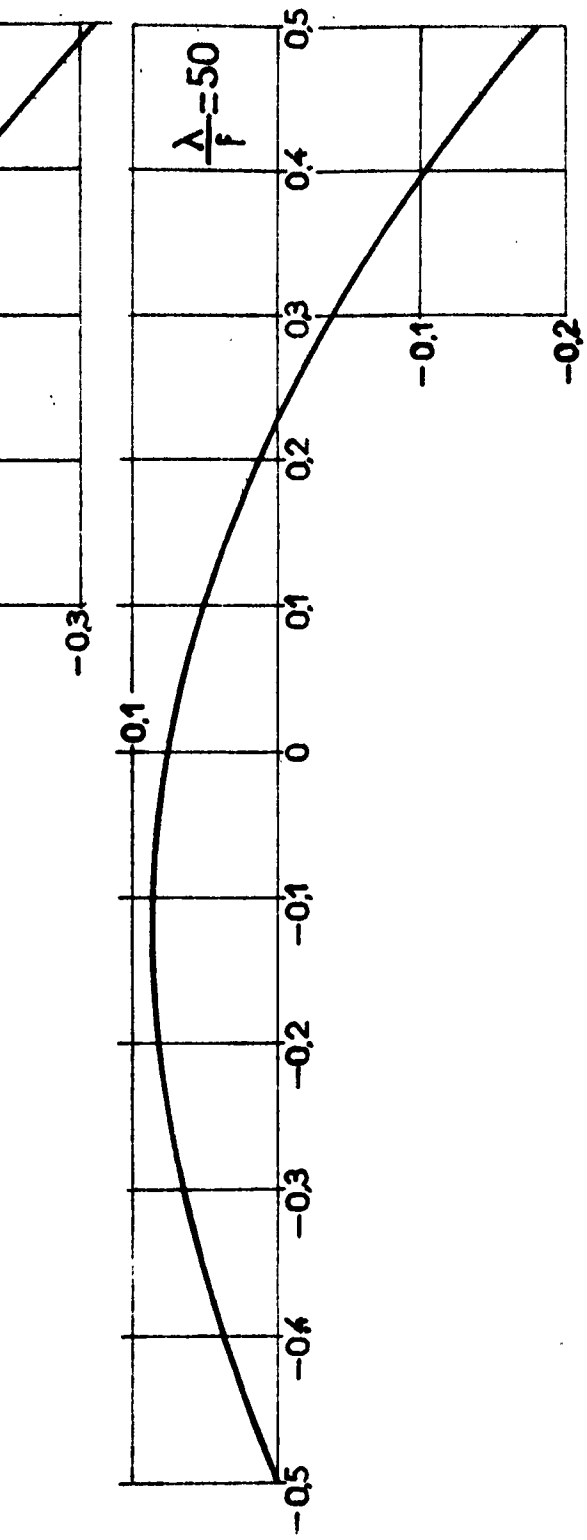
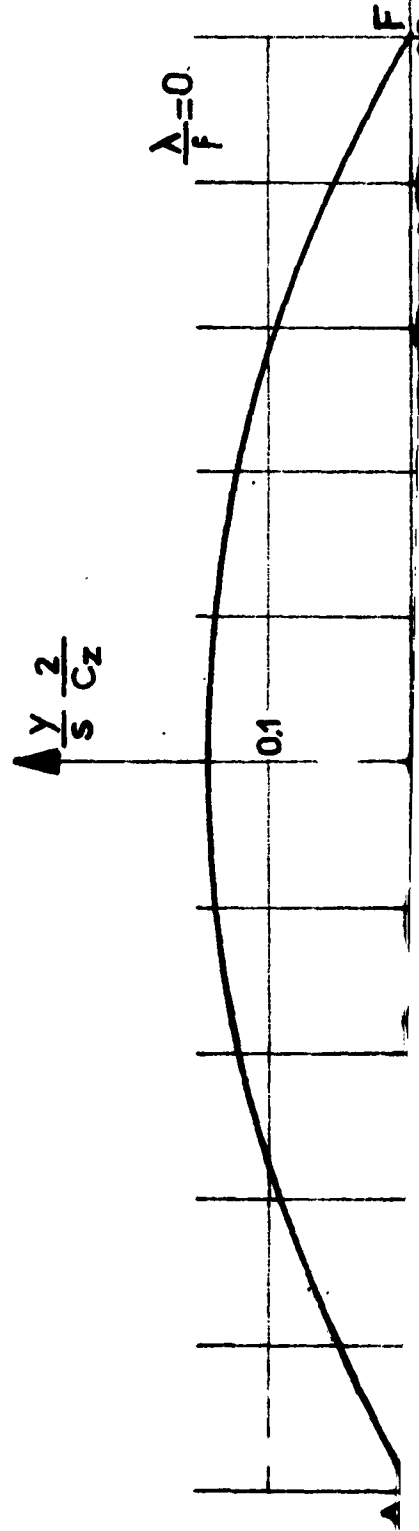
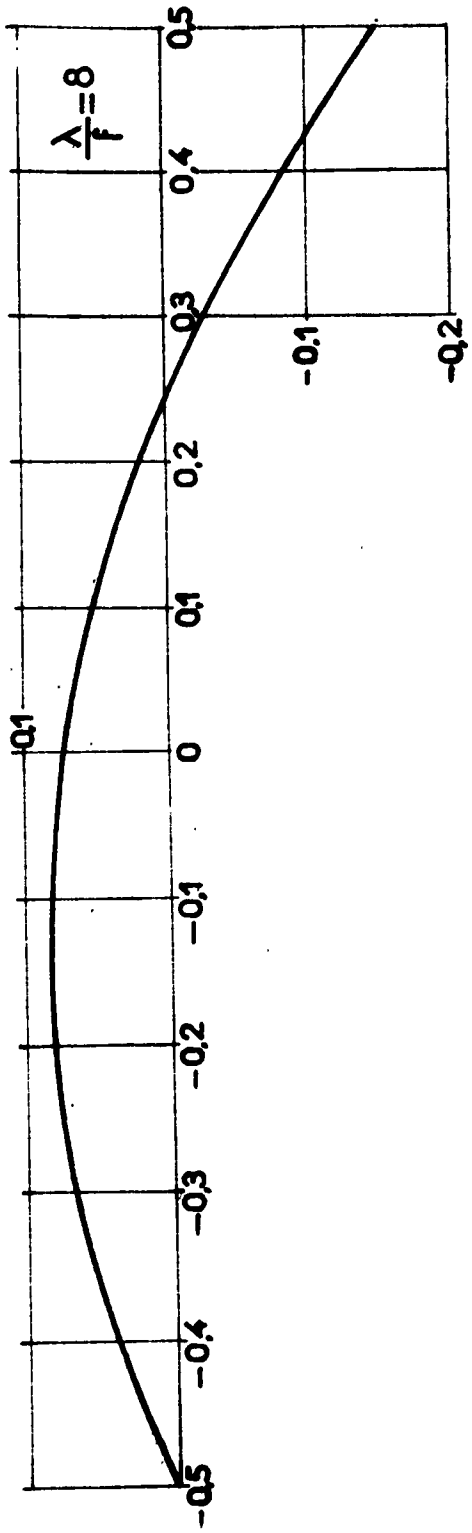
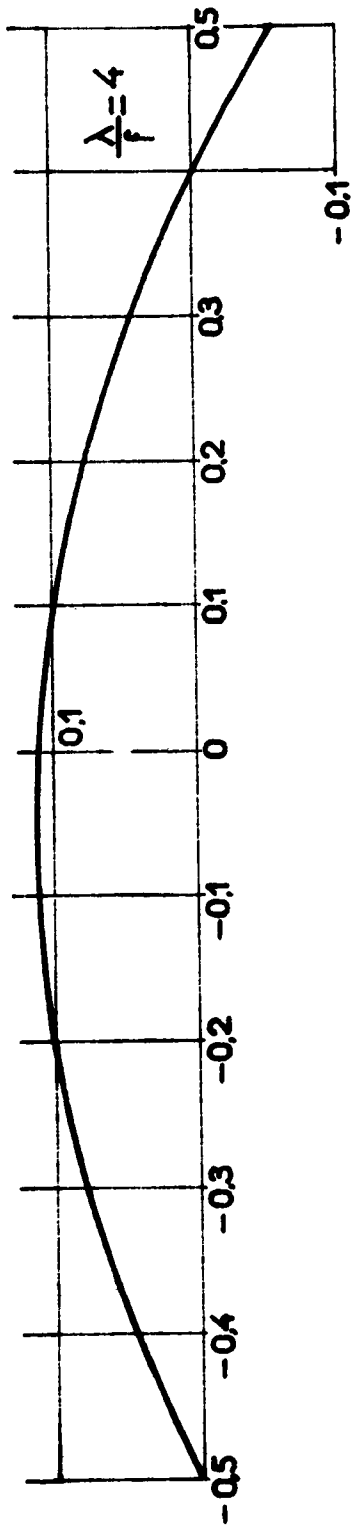
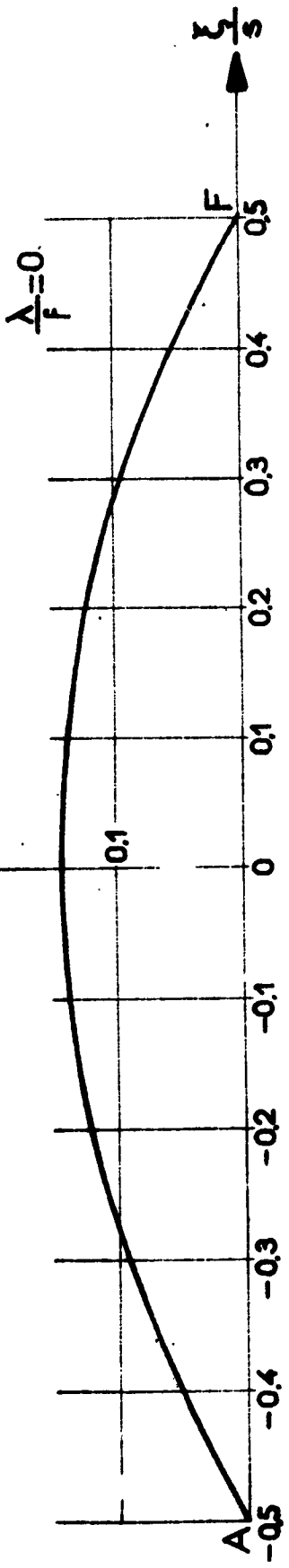

Fig: 3.8

LIGNES MOYENNES POUR $S=f$
Mean lines for $S=f$



CZ



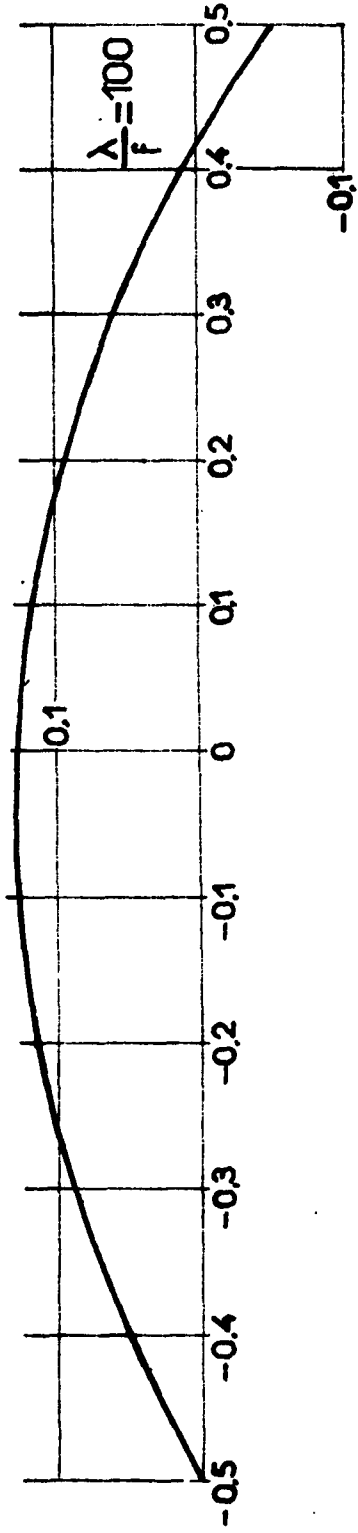
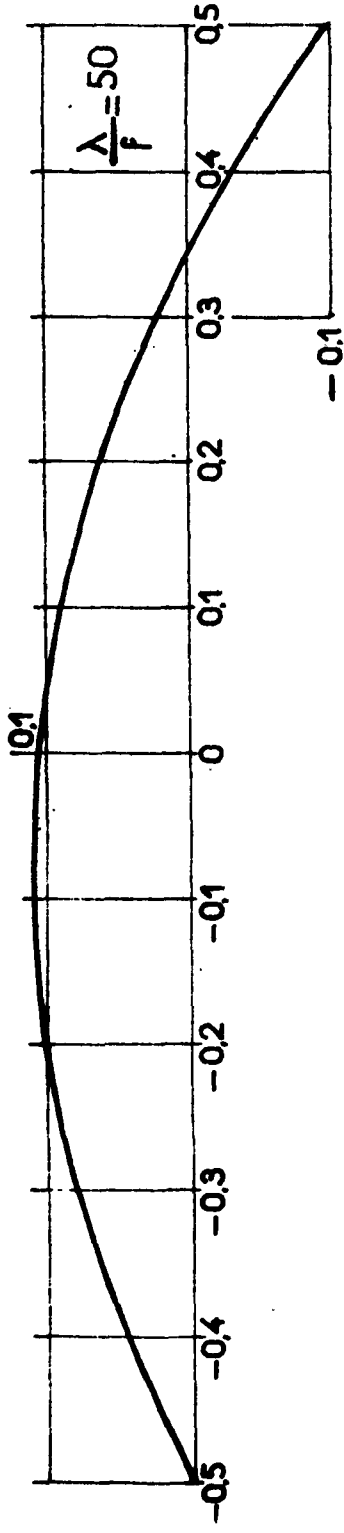
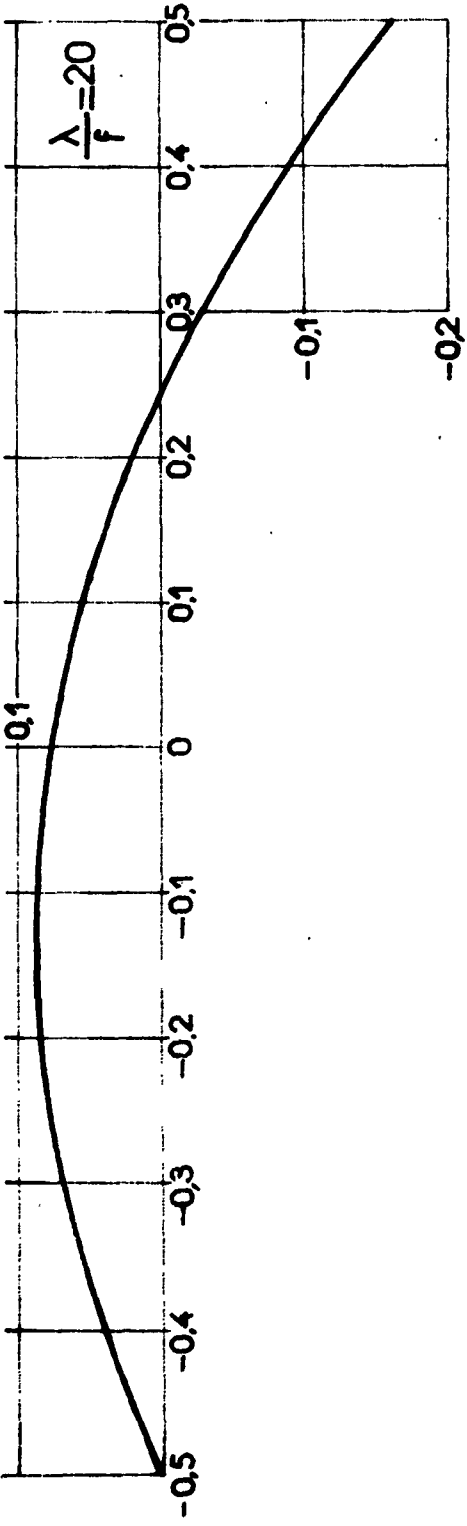

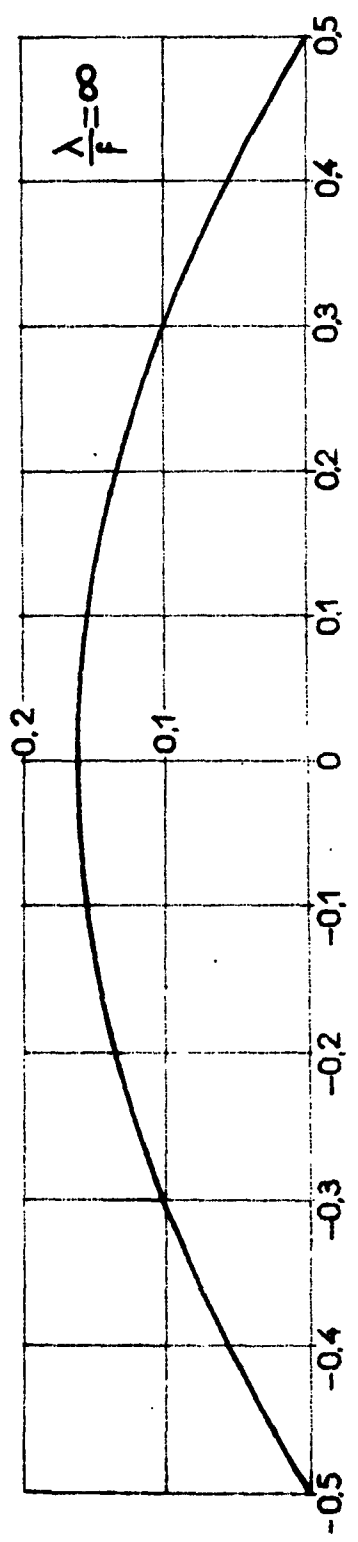
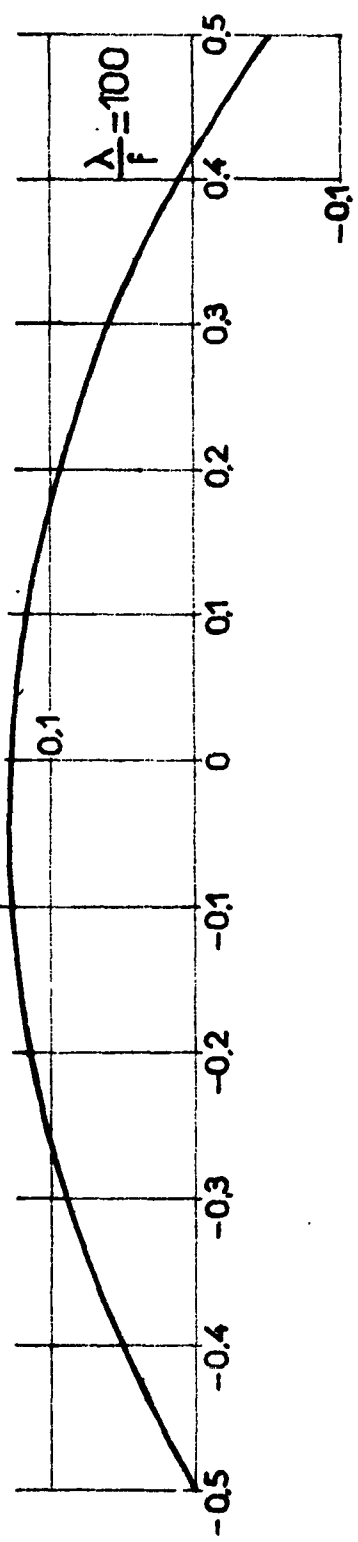
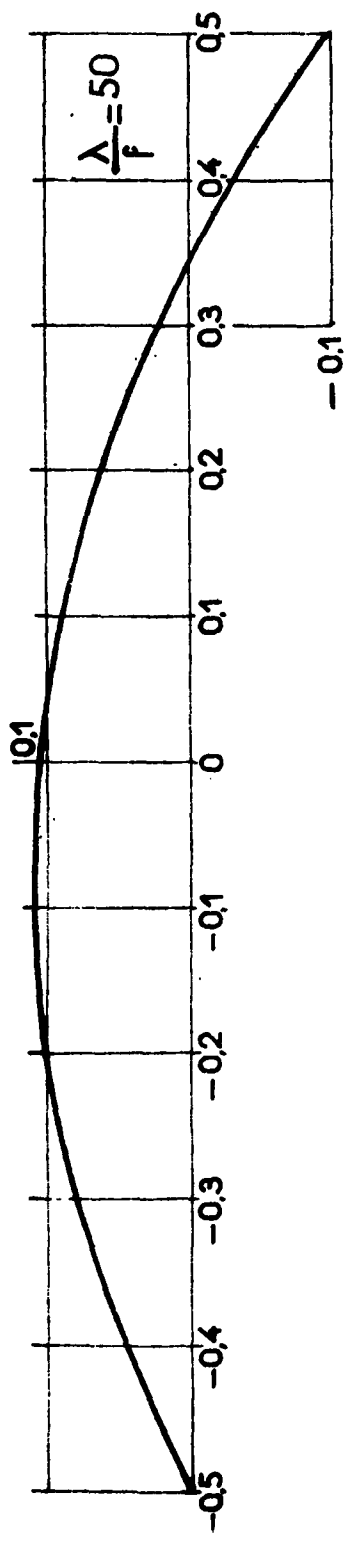

4. Analog Determination of the Shape of a Thick non lifting Profile when the thickness law is imposed.

4.1. Set-up of the problem and chosen pressure law.

Which has been defined as thickness effect in the illimited two-dimensional flow, now loses its simplicity and its meaning since the symmetrical thick profile constituting the hydrofoil near the free surface is exposed to a velocity dissymmetry between its upper surface and its lower surface, even when its angle of incidence is equal to zero, Obviously, this dissymetry depends on the shape of the free surface defined for each pair of the values $\frac{f}{\Lambda}$ and $\frac{f}{s}$.

We intend to find out the deformation to be given to a symmetrical thick profile in order to avoid the lifting effect ° which appears when it is located in a flow limited by the free surface.

We have chosen as thickness law, because of the assumption of the small perturbations, the thickness law which gives a sharp profile at both ends. The infinite slopes at the leading edge are thus avoided. Besides, the thickness distribution is symmetrical with respect to the y's axis. It can be written as follows :

$$\frac{e}{e_{\max}} = 1 - 4\left(\frac{y}{s}\right)^2 \quad -\frac{s}{2} \leq y \leq \frac{s}{2} \quad (4.1.)$$

° In fact, the symmetrical profile at zero incidence located near the free surface of the flow will have such a pressure distribution that the lift will be directed downside.

where s represents the chord of the profile ; the origin of the abscissae is taken at the middle of the profile.

4.2. Boundary conditions and formulae.

a) On the segment representing the profile, the perturbation stream function takes on values determined by the chosen thickness law.

Therefore :

$$\frac{\Delta \Psi}{V_0} = \frac{\Psi^+ - \Psi^-}{V_0} = y^- - y^+ = e \quad (4.2.)$$

and, if we consider the ratios of these values to the maximum thickness :

$$\frac{1}{V_0 e_{\max}} \Delta \Psi = \frac{1}{V_0 e_{\max}} (\Psi^+ - \Psi^-) = 1 - 4 \left(\frac{\xi}{s} \right) \frac{-s/2}{2} \frac{\xi/s}{2} \quad (4.3.)$$

b) By replacing the profile by N sources and N sinks set along its projection and symmetrically with respect to y , the wave shape of the free surface will be considered as the superposition of the effect of each punctual source and sink. The contribution due to a source or a sink having a mass flow equal to ΔQ and located at the dot : $x = \xi_n, y = -f$, is $\eta^*(x, \xi_n) \frac{\Delta Q \xi}{V_0}$.

According to (2.33.), we have :

$$\eta^*(x, \xi_n) = \eta \frac{V_0}{\Delta Q} = 2e^{-Kf} \cos K(x - \xi_n) \frac{1}{\pi} \int_0^{\infty} \frac{(K \cos mf + m \sin mf) e^{-m(x - \xi_n)}}{m^2 + K^2} dm$$

$$\eta^*(x, \xi_n) = \eta \frac{V_0}{\Delta Q} = \frac{1}{\pi} \int_0^{\infty} \frac{(K \cos mf + m \sin mf) e^{m(x - \xi_n)}}{m^2 + K^2} dm$$

$x > 0$ (4.4.)

where ΔQ represents the mass flow of a source equivalent to the profile (see § 1.3.) between any two ordinates. We shall define the value of this mass flow as a function of (4.1.).

$$e = e \max \frac{4}{S^2} \left[\frac{S^2}{4} - \xi^2 \right] = y^+ - y^- \quad (4.5.)$$

The values of the perturbation velocities v^+ and v^- can be obtained when taking into account the sliding condition (1.8.), and in derivating (4.5.)

$$v^+ - v^- = V_0 \left(\frac{\partial y^+}{\partial x} - \frac{\partial y^-}{\partial x} \right) = - \frac{8}{S^2} V_0 e \max \xi \quad (4.6)$$

The mass flow of an elementary source will be given by :

$$dQ = (v^+ - v^-) d\xi \quad (4.7.)$$

and, by integrating between $\xi_n - \frac{\Delta \xi}{2}$ and $\xi_n + \frac{\Delta \xi}{2}$

$$\Delta Q_{\xi_n} = \int_{\xi_n - \frac{\Delta \xi}{2}}^{\xi_n + \frac{\Delta \xi}{2}} - \frac{8}{S^2} V_0 e \max \xi_n d\xi = - \frac{8}{S^2} V_0 e \max \xi_n \Delta \xi \quad (4.8.)$$

for $-\frac{S}{2} < \xi_n < \frac{S}{2}$

If we replace (4.8.) in (4.4.) to estimate the wave motion of the free surface, and if we take into account (1.12.), we obtain a Dirichlet condition for the free surface :

$$\eta(x) = \eta^*(x, \xi_n) \quad \frac{\Delta Q_{\xi_n}}{V_0} = -\eta^*(x, \xi_n) \frac{8e \max \xi_n \Delta \xi}{S^2} \quad (4.9.)$$

We can write, to make this expression dimensionless :

$$\frac{\eta(x)}{e \max} = \eta^*(x, \xi_n) \frac{g}{s^2} \xi_n \Delta \xi \quad (4.10.)$$

and if we make the sum for all the sources and sinks which replace the profile :

$$\sum_{n=1}^{n=2N} \frac{\eta(x)}{e \max} = -\frac{g}{s^2} \Delta \xi \left[\sum_{n=1}^{n=N} \eta^*(x, \xi_n) \xi_n + \sum_{n=N+1}^{n=2N} \eta^*(x, \xi_n) \xi_n \right] \quad (4.11.)$$

If we take into account the fact that for the sources and sinks the absolute value of ξ_n is the same but of opposite sign, we shall have, for a symmetrical distribution of sources and signs :

$$\frac{\Psi}{V_0 e \max} = \sum_{n=1}^{n=N} -\frac{\eta(x)}{e \max} = \frac{g}{s^2} \Delta \xi \left[\sum_{n=1}^{n=N} \eta^*(x, \xi_n) - \sum_{n=N+1}^{n=2N} \eta^*(x, -\xi_n) \right] \xi_n \quad (4.12.)$$

The first member represents, to a constant, the values of the potential to be set at the free surface.

c) for $x = -\infty$, the perturbation potential is equal to zero, therefore :

$$\Psi(-\infty, y) = 0$$

d) Like in 3.3.d) at downstream infinity, the only term which remains in the first expression of (4.4.) is :

$$\frac{\Psi(x, \xi_n)}{V_0} = -\eta^*(x, \xi_n) = -2 e^{-Kx} \cos K(x - \xi_n) \quad (4.13.)$$

For the whole symmetrical lot of sources and sinks, we obtain :

$$\eta(x, \xi_n) - \eta(x_1 - \xi_n) = 2e^{-Kf} \left[\cos K(x - \xi_n) - \cos K(x + \xi_n) \right]$$

$$= 4e^{-Kf} \sin K \xi_n \sin Kx$$

And finally, according to (4.12.) :

$$\frac{\Psi}{V_{oe \max}} = \frac{32}{S^2} e^{-Kf} \Delta \xi \sum_{n=N+1}^{n=2N} \xi_n \sin Kx \sin K \xi_n \quad (4.14.)$$

The maximum or minimum value will be obtained for $x = (2n+1) \frac{\Delta}{4}$.
From this abscissa, the stream function will be so that :

$$\frac{\partial \Psi}{\partial x} = 0$$

as the vertical component of the perturbation velocity is equal to zero.

e) for $y = -\infty$ we suppose that the flow will not be perturbed ;
the Ψ function will therefore be equal to zero.

$$\Psi(x, -\infty) = 0$$

4.2.1. We shall consider the Ψ function as the sum of two functions Ψ_1 and Ψ_2 which are ruled by the following boundary conditions :

<u>Function</u> Ψ_1	<u>Function</u> Ψ_2
a) at the free surface	a')
$\Psi_1 = 0$	$\frac{\Psi_2}{V_{oemax}}$ (formula 4.13.)
b) on the profile	b')
$\frac{\Psi_1^+ - \Psi_1^-}{V_{oemax}} = 1 - 4\left(\frac{\xi}{S}\right)^2$	$\frac{\Psi_2^+ - \Psi_2^-}{V_{oemax}} = 0$
c) at downstream infinity	c') at $x = (2n+1)\frac{\lambda}{4}$
$\Psi_1 = 0$	$n = 0, 1, 2, \dots, n$
d) at upstream infinity	d')
$\Psi_1 = 0$	$\frac{d\Psi_2}{dx} = 0$
e) for $y = -\infty$	e')
$\Psi_1 = 0$	$\Psi_2 = 0$

The Ψ_1 and Ψ_2 potential measurement on the electrodes of the plate allows, through the sliding condition on the profile, defined in (§1.14.) the determination of the ordinates y^+ and y^- . Paragraph 4.3.3. shows the operations leading to this determination.

Figure 4.1. represents the boundary conditions expressed above.

4.3. Analog representation and experiments.

The experiments have been realized in a quasi-indefinite rheoelectrical set-up whose characteristics have been given in 3.4.

4.3.1. Representation of the function Ψ_1 .

The condition b) of 4.2.1. on this profile is obtained by feeding each pair of electrodes of the plate through a transformer with a separate feeding T and having a 1/3 ratio ; its secondary contains a potentiometer p. Obviously, the electrodes are not connected one to another. The measurement of the potentials is effected by the mean of a measurement bridge PM, fed by a transformer having a 1/3 ratio, so as to avoid a current supply of the electrodes during the conduct of the measurement (Fig. 4.2.a).

The limits of the field are covered with a continuous electrode connected to the zero of the measurement bridge in the same way as in 3.4.1.

The voltage between two electrodes of the plate will be proportional to the expression (4.1.). On these electrodes, we measure the values of electrical potentials proportional to $\frac{\Psi^+ \xi}{V_0 e \max}$ and $\frac{\Psi^- \xi}{V_0 e \max}$.

According to (1.14.) and calling Ψ_{1A}^+ the reference potential measured at the leading edge, we can write :

$$\frac{y_1^+ \xi}{e \max} = - \frac{\Psi_{1\xi}^+ - \Psi_{1A}^+}{V_0 e \max} \quad \text{and} \quad \frac{y_1^- \xi}{e \max} = - \frac{\Psi_{1\xi}^- - \Psi_{1A}^-}{V_0 e \max} \quad (415.)$$

4.3.2. Representation of the function Ψ_2 .

On the electrodes representing the free surface, we are setting the electrical potential values proportional to (4.13.) - condition 4.2.1. a' - On the other limits of the field, the conditions are those of 3.4.2. (figure 4.2.b).

According to condition 4.2.1. b' :

$$\frac{\Psi_2^+}{V_0 e \max} = \frac{\Psi_2^-}{V_0 e \max}$$

where $\Psi_2^+ = \Psi_2^-$

The electrodes of the plate must now be connected two by two. We shall measure on these electrodes an electrical potential which will be proportional to $\frac{\Psi_2}{V_0 e \max}$.

We can write that, to a constant :

$$\frac{y_2^+ \xi}{e \max} = \frac{y_2^- \xi}{e \max} = - \frac{\Psi_2^+ \xi - \Psi_{2A}^+}{V_0 e \max} = - \frac{\Psi_2^- \xi - \Psi_{2A}^-}{V_0 e \max} \quad (4.16.)$$

where Ψ_{2A}^+ represents the electrical potential at the leading edge.

4.3.3. Composition of the functions Ψ_1 and Ψ_2

The addition of formula (4.15.) and (4.16.) permits to define the ordinates of the profile in the following way :

$$\frac{y_1^+ \xi}{e \max} = \frac{y_1^+ \xi + y_2^+ \xi}{e \max} = \frac{1}{V_0 e \max} \left[(\Psi_1^+ \xi - \Psi_{1A}^+) + (\Psi_2^+ \xi - \Psi_{2A}^-) \right] \quad (4.17.)$$

and :

$$\frac{y_1^- \xi}{e \max} = \frac{y_1^- \xi + y_2^- \xi}{e \max} = - \frac{1}{V_0 e \max} \left[(\Psi_1^- \xi - \Psi_{1A}^-) + (\Psi_2^- \xi - \Psi_{2A}^-) \right] \quad (4.18.)$$

which respectively give the upper and lower surfaces of a non lifting profile for each pair of parameters having a flow $\frac{f}{s}$ and $\frac{f}{\Lambda}$.

4.4. Experiments and results.

Figures 4.3, and 4.4. show the results obtained for two series of experiments where the shape of the profile is given as a function of $\frac{y}{e \max}$ and $\frac{y}{s}$. One can notice that the dissymmetry of the velocities due to the presence of the free surface makes the incidence angle increase : this angle is generally small with respect to those due to the lift effect for usual values of $e \max/s$ and of C_L .

We have noticed in the course of the experiments, that the profile remains nearly symmetrical for $\frac{f}{\Lambda}$ limits, 0 and ∞ , and for depths superior to half a chord. This fact can be explained in the light of the small perturbation assumptions which we had set forth from the beginning.

Conditions limites de la représentation analogique
épaisseur

Boundary conditions of the analog representation - thickness

Function Ψ_1

$$\Psi_1 = 0$$

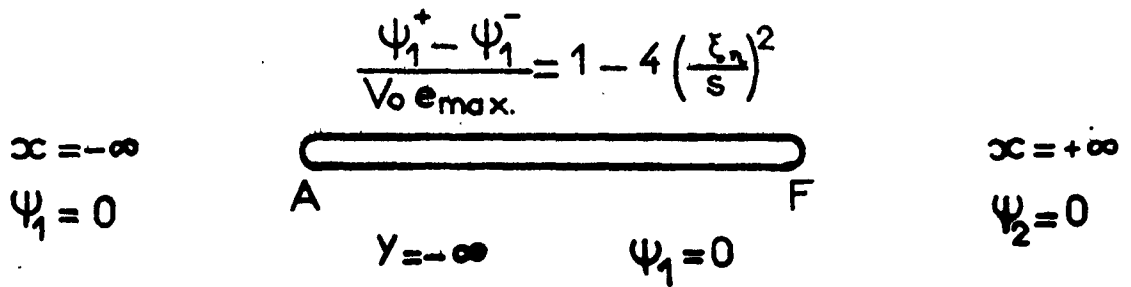

Function Ψ_2

$$\frac{\Psi_2}{V_0 e_{\max}} = \sum \eta(x, \xi_n) \frac{\Delta Q \xi_n}{V_0}$$

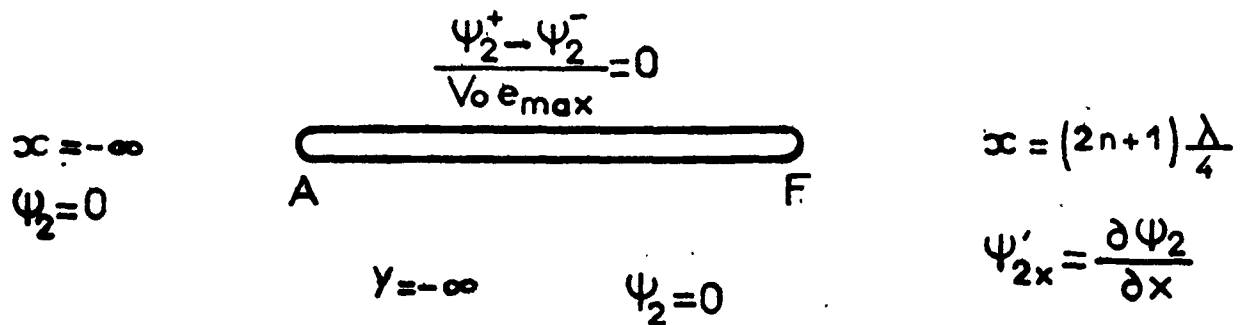
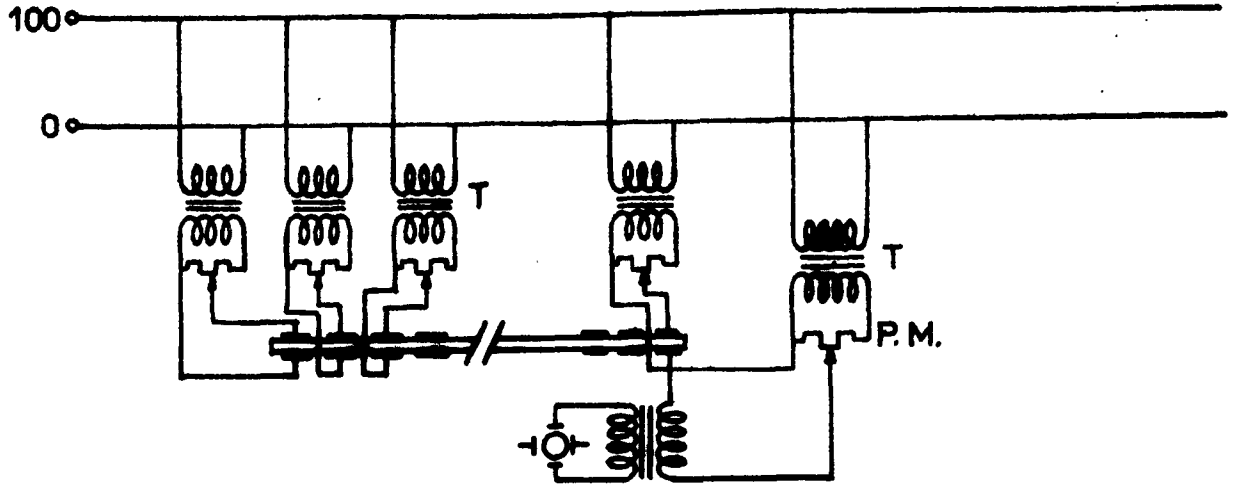

Fig: 4.1

EFFET D'ÉPAISSEUR THICKNESS EFFECT

Function Ψ_1



Function Ψ_2

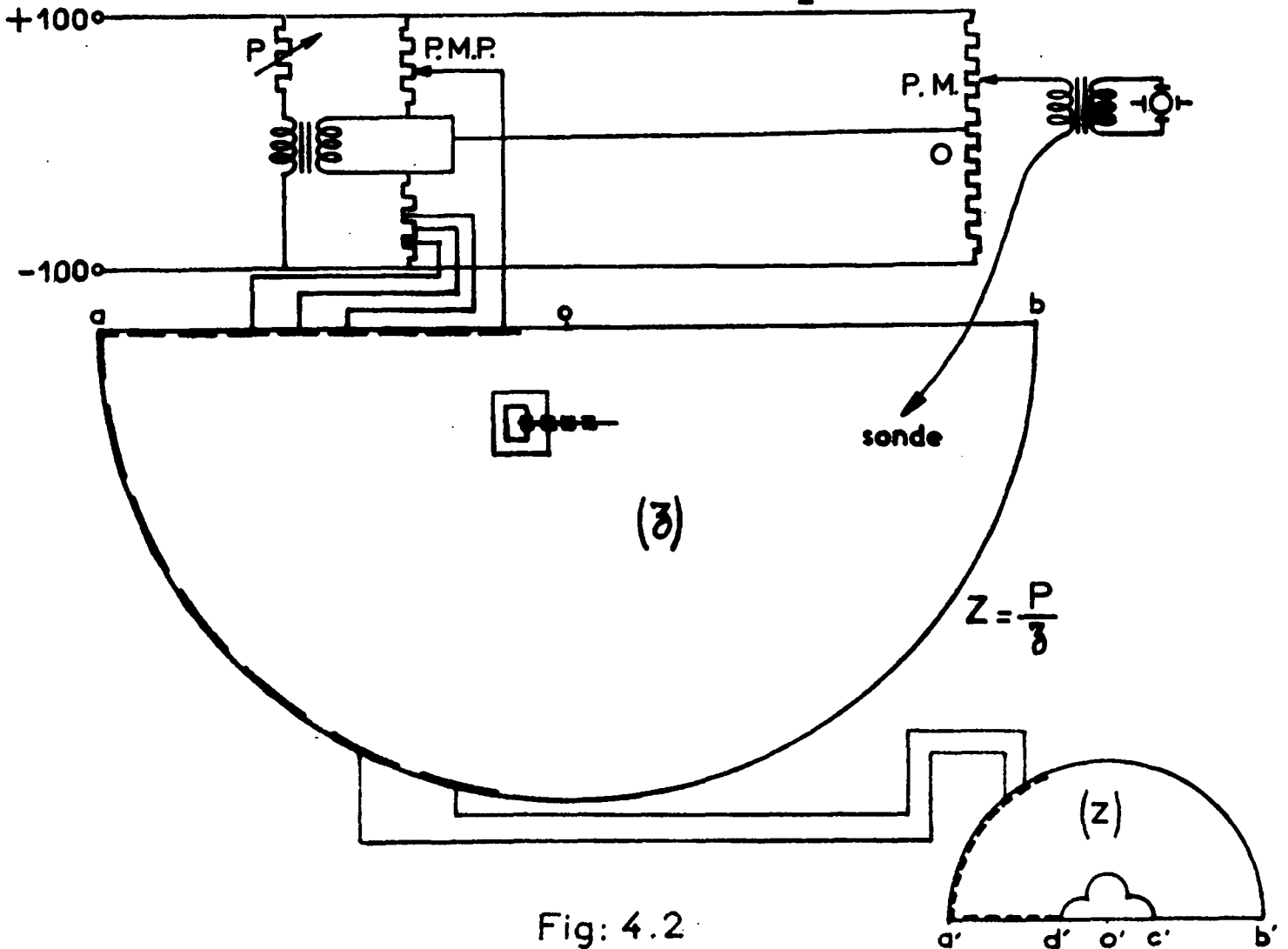

Fig: 4.2

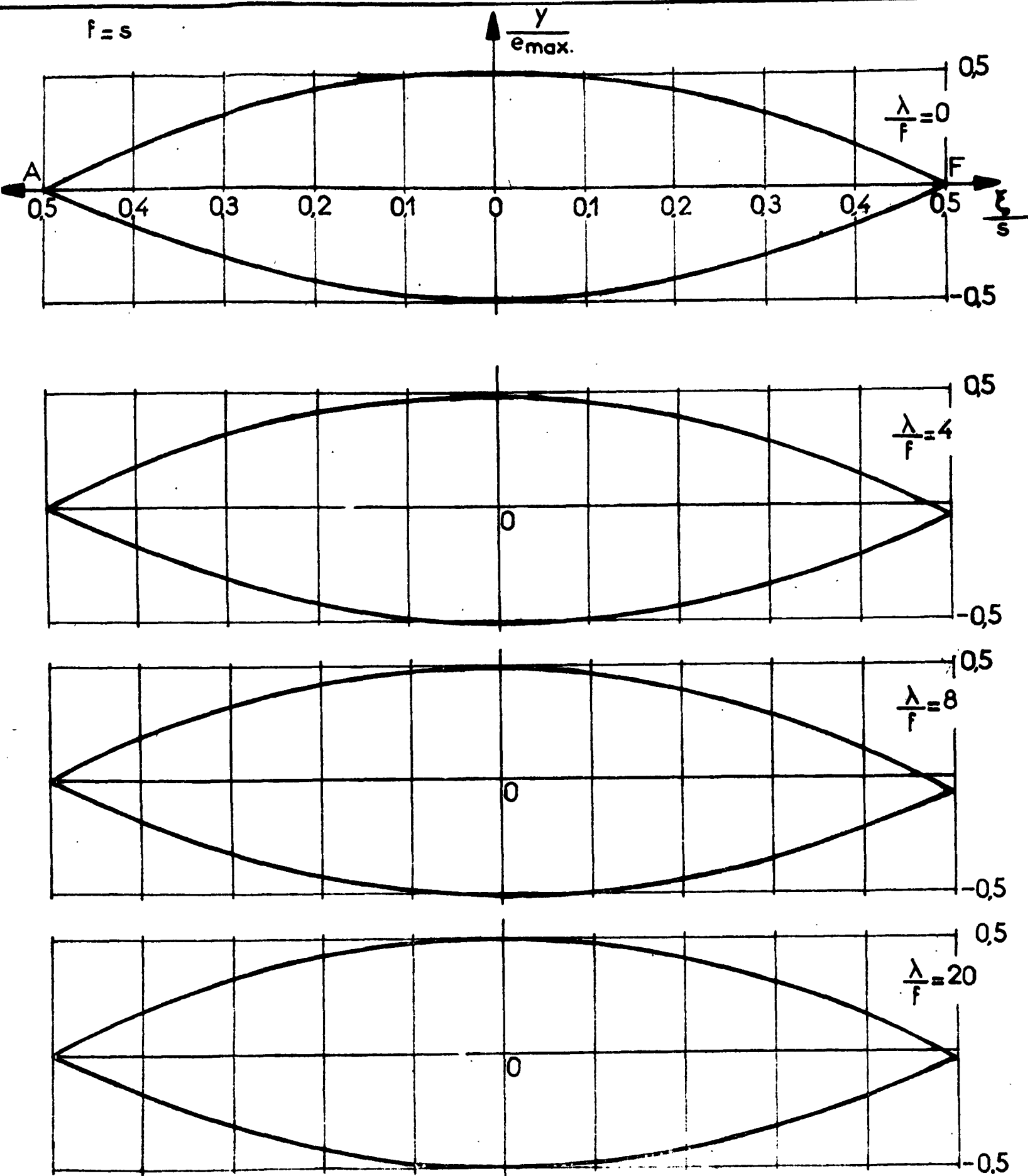

Fig: 4.3

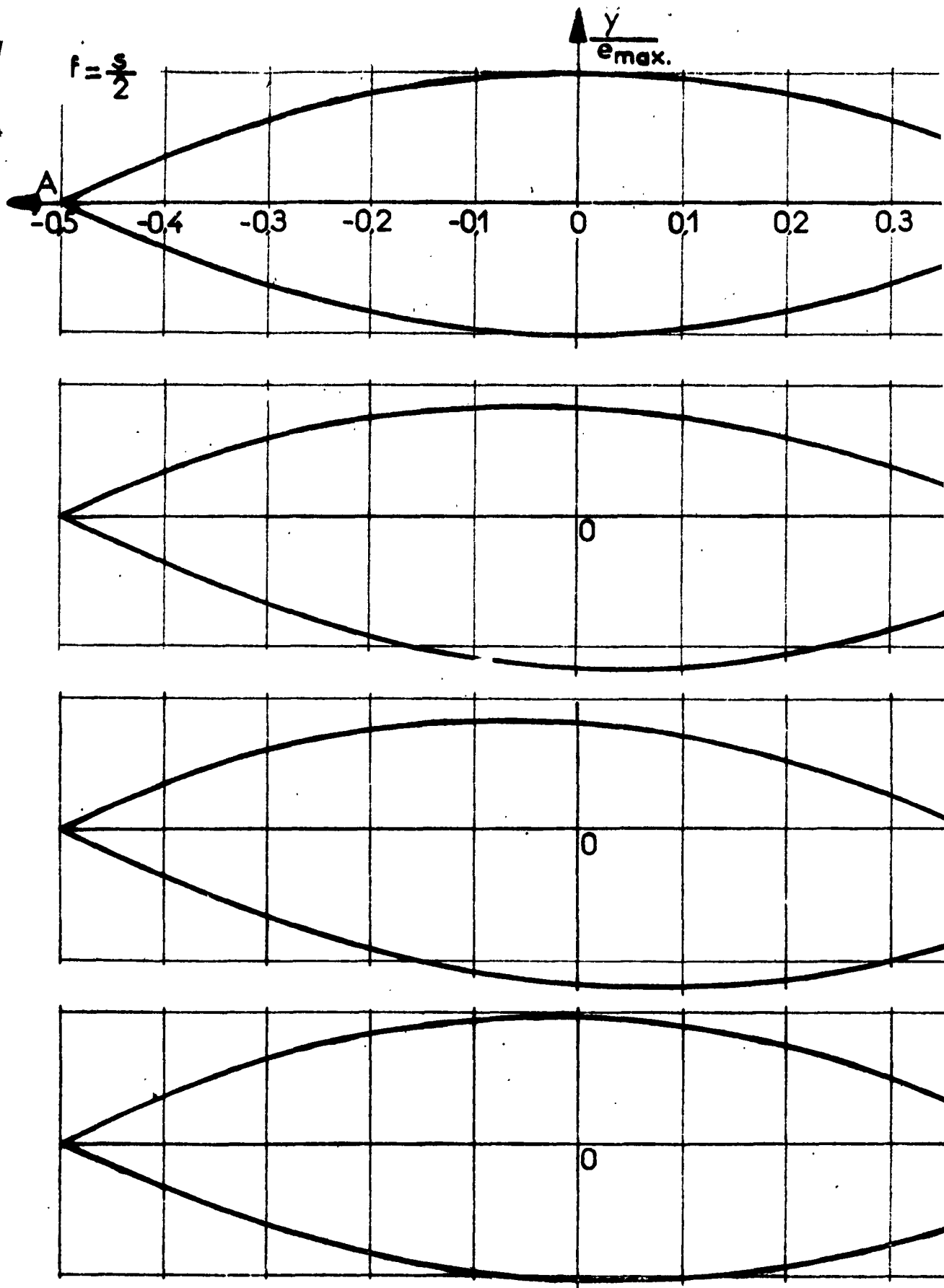

Fig: 4.4

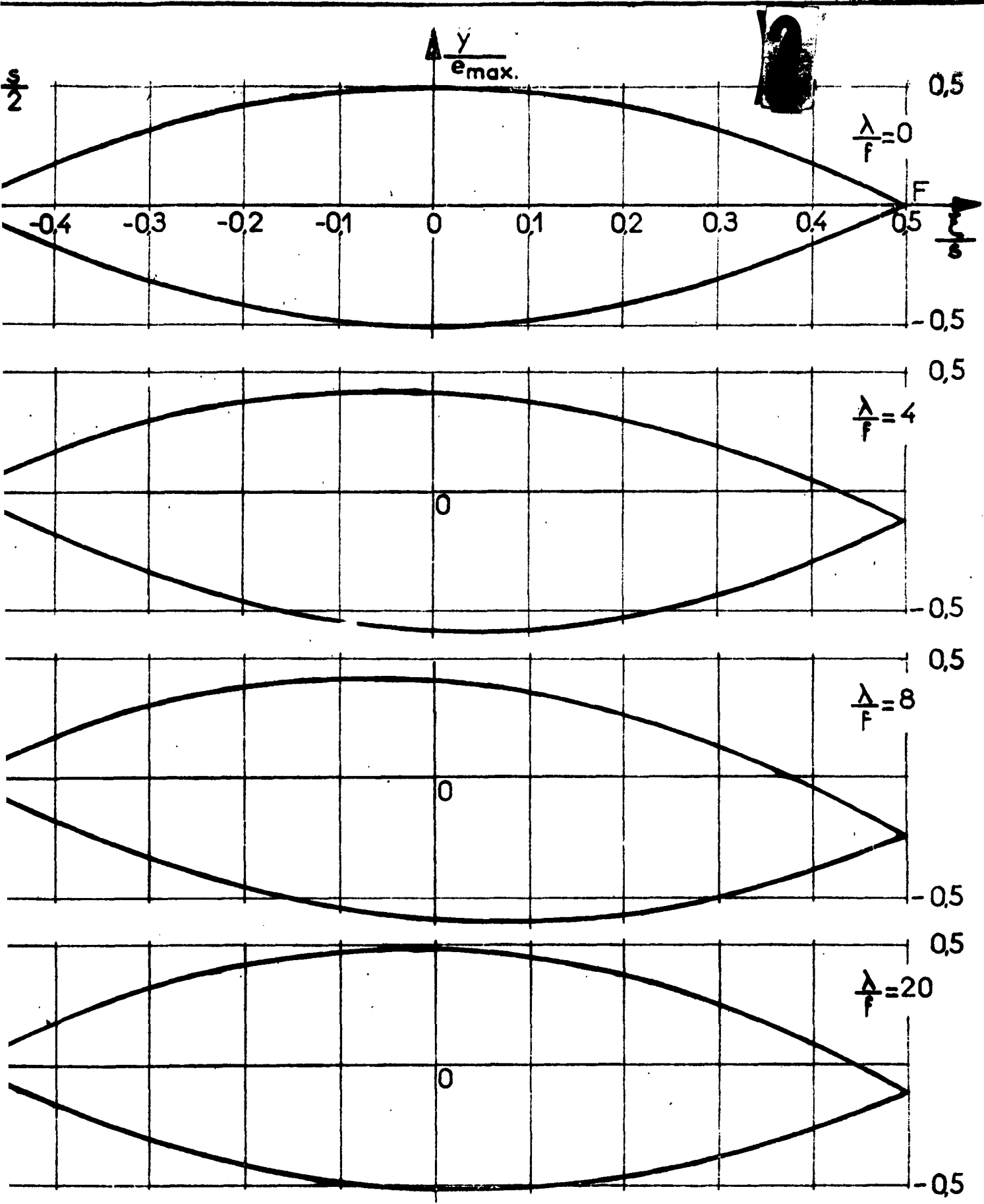

Fig: 4.4

BIBLIOGRAPHY.

- 1) VLADIMIROV A.N. - "Approximate hydrodynamic design of a finite span hydrofoil". (Traduction anglaise. NACA. Juin 1955)
 - 2) NISHIYAMA Tetsuo - "Hydrodynamical Investigation on the Submerged hydrofoil". A.S.N.E. Journal. Août 1958.
 - 3) AUSMAN J.S. - "Experimental Investigation of the influence of submergence depth upon the wave-making resistance of an hydrofoil". Master of Sc. thesis. Univ. of California. 1952.
 - 4) PARKIN B.R., PERRY B. and WU T. Yao-Tau - "Pressure Distribution on a Hydrofoil running near the Water Surface". Journal of Applied Physics. Vol 27, n° 3. March 1956.
 - 5) ISAY W.H. - "Zur Theorie der nahe der Wassero berfläche fahrenden Tragflächen". Ingenieur-Archiv. Vol. XXVII. 1960.
 - 6) NISHIYAMA Tetsuo - "Hydrodynamical Investigation on the submerged Hydrofoil". A.S.N.E. Journal. Nov. 1958.
 - 7) PARKIN B.R. and PEEBLES G.H. - "Calculation of Hydrofoil Sections for Prescribed Pressure Distributions". The Society of Naval Architects and Marine Engineers. Technical and Research Bulletin n° 1-17.
 - 8) MILNE-THOMSON L.M. - "Theoretical Hydrodynamics". 4e édition. page 210 et suivantes.
 - 9) LAMB H. - "Hydrodynamics". Page 410.
 - 10) NACA Wartime Report. March 1945.
 - 11) RENARD G. - "Représentation directe, par analogie rhéoelectrique, des gradients de fonctions harmoniques en domaine plan limité ou illimité." Publications Scientifiques et Techniques du Ministère de l'Air. n° NT 78, 1958, Paris.
 - 12) MALAVARD L. - "La méthode d'analogie rhéoelectrique, ses possibilités et ses tendances". 1ères Journées Intern. de Calcul Analogique Bruxelles. Sept. 1955.
 - 13) MALAVARD L. - " L'emploi des analogies rhéoelectriques en aérodynamique". AGARDograph. 18.
-