

UNCLASSIFIED

AD 296 999

*Reproduced
by the*

**ARMED SERVICES TECHNICAL INFORMATION AGENCY
ARLINGTON HALL STATION
ARLINGTON 12, VIRGINIA**



UNCLASSIFIED

NOTICE: When government or other drawings, specifications or other data are used for any purpose other than in connection with a definitely related government procurement operation, the U. S. Government thereby incurs no responsibility, nor any obligation whatsoever; and the fact that the Government may have formulated, furnished, or in any way supplied the said drawings, specifications, or other data is not to be regarded by implication or otherwise as in any manner licensing the holder or any other person or corporation, or conveying any rights or permission to manufacture, use or sell any patented invention that may in any way be related thereto.

CATALOGED BY ASIA
AS AD NO. _____

296999

**LOCKHEED
CALIFORNIA
COMPANY**

BURBANK, CALIFORNIA, U.S.A.

TRANSIENT LONGITUDINAL STABILITY
OF A SMALL
SURFACE PIERCING HYDROFOIL BOAT

LR/16112 18 JULY 1962

296 999

A LIMITED INVESTIGATION
INTO THE
TRANSIENT LONGITUDINAL STABILITY
OF A SMALL
SURFACE PIERCING HYDROFOIL BOAT

- FINAL REPORT -

U.S. Navy Contract Nonr-3401(00)
Task Number NR-062-267



Fox Conner
Senior Research Engineer

Approved:



A. W. Turner
Flight Test Research Staff Engineer



for J. G. Reel
Chief Flight Test Engineer

~~THE INFORMATION DISCLOSED HEREIN WAS ORIGINATED BY AND IS THE PROPERTY OF
THE LOCKHEED AIRCRAFT CORPORATION, AND EXCEPT FOR USES EXPRESSLY GRANTED TO
THE UNITED STATES GOVERNMENT, LOCKHEED RESERVES ALL PATENT, PROPRIETARY,
DESIGN, USE, SALE, MANUFACTURING AND REPRODUCTION RIGHTS THERE TO. INFOR-
MATION CONTAINED IN THIS REPORT MUST NOT BE USED FOR SALES PROMOTION OR
ADVERTISING PURPOSES.~~

LOCKHEED-CALIFORNIA COMPANY
A Division of Lockheed Aircraft Corporation

FINAL REPORT
LR/16112

SUMMARY

An attempt was made to verify stability theory for surface piercing hydrofoils by conducting transient longitudinal stability tests on the Lockheed LH-2 hydrofoil research boat. A step input was obtained by suddenly changing the incidence of the forward hydrofoil nose down one degree. The correlation between the time histories from the tests and from the computer studies was unsatisfactory. Partial and full chord ventilation are suspected of causing the discrepancy between theory and test results.

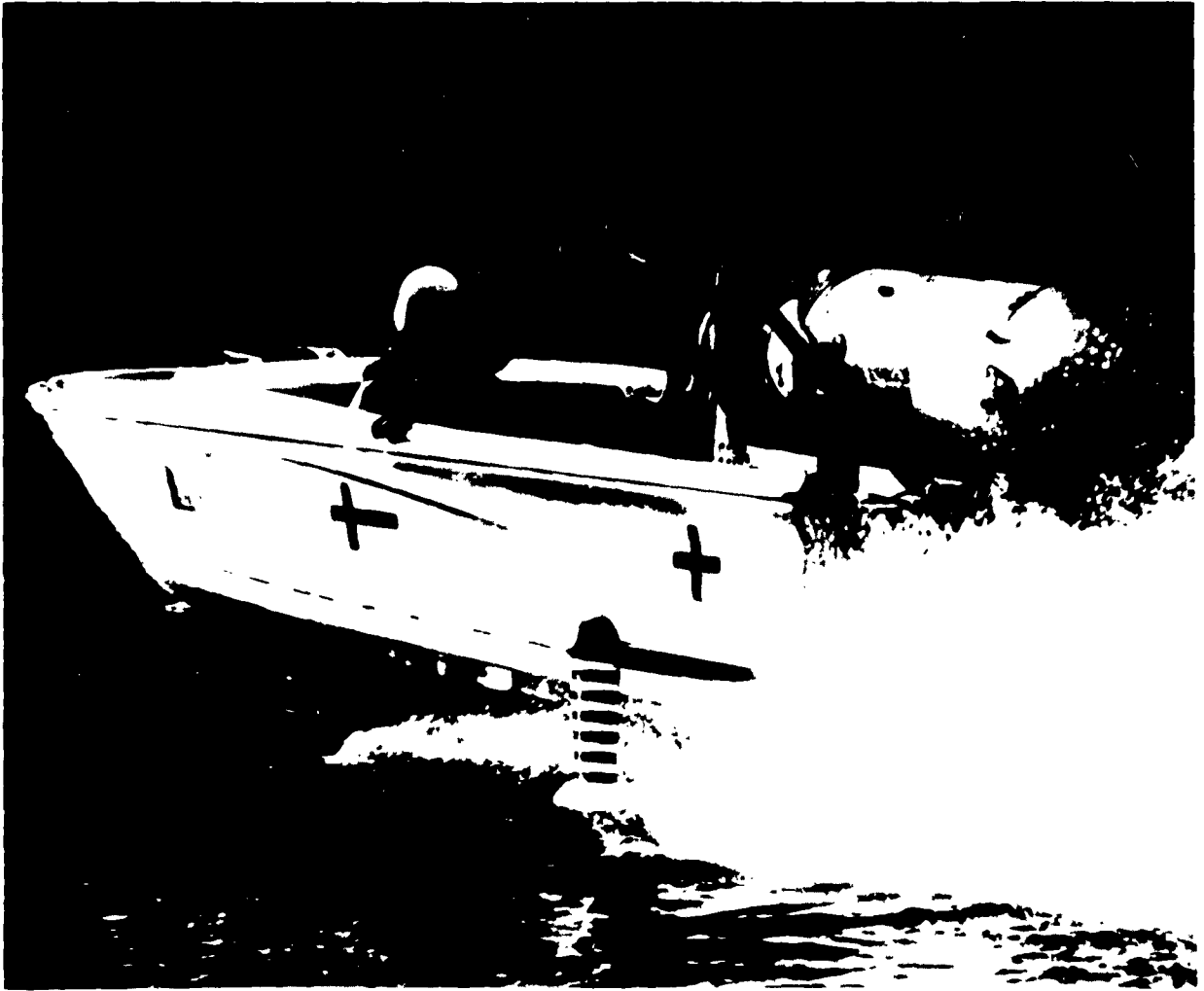

"IN FLIGHT"

FINAL REPORT
LR/16112

CONTENTS

	Page
SUMMARY	1
INTRODUCTION	3
THEORY	3
TESTS	3
DISCUSSION	5
RECOMMENDATIONS	7
APPENDIX	
References	7
Glossary of Symbols	8
Table 1	10
Table 2	11
Table 3	12
Table 4	13
Figure 1 Forward Hydrofoil	14
Figure 2 Front View of Left Aft Hydrofoil	15
Figure 3 View of Hydrofoil Configuration	16
Figure 4 Observer's "pull-handle" and Bow Camera	16
Figure 5 Forward Hydrofoil In Flight	17
Figure 6 Aft Hydrofoil In Flight	18
Figure 7 Setup for "Bounce" Test	19
Figure 8 Transient Longitudinal Stability Test 35, Run 4	20
Figure 9 Transient Longitudinal Stability Test 36, Run 1	21
Figure 10 Transient Longitudinal Stability Test 36, Run 2	22
Figure 11 Time History Comparison Test 36, Run 1	23

INTRODUCTION

Hydrofoil boats are rapidly gaining favor as high speed water vehicles. During the last ten years, a great deal of effort has been expended in hydrofoil research including the field of vehicle stability. To date, however, there appears to be only one attempt to verify the equations of motion for a full scale vehicle (Reference 1). This was done on a 20 foot fully submerged hydrofoil boat. No studies have been made to verify stability theory for surface piercing hydrofoils where the surface effects predominate. In the previously mentioned equations of motion study, the surface effect (depth derivative) was neglected. As a result, a decision was made to conduct transient longitudinal stability tests with the Lockheed LH-2 hydrofoil research boat.

The study reported here was conducted under U.S. Navy Contract Nonr-3401(00). All the tests were run at the Morris Dam Facilities of the U.S. Naval Ordnance Test Station in Azusa, California.

THEORY

Both linear and non-linear longitudinal equations of motion were investigated. The equations are listed in Table 1 where all parameters are increments from their initial values. Body axes are employed with the positive X axis pointing forward, the positive Y axis pointing starboard and the positive Z axis pointing downward and with the origin at the center of gravity. The XZ plane is the vertical plane of symmetry and the XY plane is parallel to the bottom planing surface of the boat. The stability derivatives for the linear equations are given in Table 2 in terms of the forces along the flow axes. The transformation from flow to body axes are the same as given by Chuck, Luke and Scroggs (Reference 2) except for being non-dimensionalized and for being simplified by assuming the side force and side slip zero by reason of symmetry.

The non-linear equations represent a balance between the lift forces on the hydrofoils and the inertia and weight of the boat. Drag was not included because the equations would be considerably more complex and because the drag terms had a relatively minor effect on the linear equations for the "short term" boat motions. The hydrofoil forces were calculated by a method due to Wadlin (References 3, 4) with check calculations by a method given in the Gibbs and Cox Hydrofoil Handbook (Reference 5).

No attempt was made to include changes in downwash, virtual mass or lag in lift. Most of these effects are small. In addition, the theory for these effects is complex and difficult to apply near a free surface. The propulsion side forces are considered negligible.

TESTS

Page 1 shows the Lockheed's research boat in flight. The boat was originally powered by two 70 hp. outboard motor power heads, each connected to a ducted fan. Air propulsion was necessary in order to conduct underwater hydrofoil noise studies with the LH-2 boat under another research contract. Difficulty was experienced with engine vibrations which caused three crankshafts to fail. As a result, the ducted fans were replaced with one surplus J44-R-24 turbojet engine of 1000 lbs. thrust.

FINAL REPORT
LR/16112

TESTS (Cont'd.)

The engine problems ceased and the work reported here was completed with the jet. Details of the hull and powerplant are listed in Table 3.

Figures 1 and 2 are drawings of the forward and aft hydrofoils, respectively. The drawings do not show the full chord ventilation fences which are visible in the photo of Figure 3. The tests were conducted by applying a step input into the forward hydrofoil incidence. The mechanism consisted of a handle at the observer's seat and two push-pull cables routed to slotted washers under an adjustment bolt at the rear attachment point. A pull on the handle pulled the washers free and suddenly changed the hydrofoil incidence nose down $\frac{1}{2}$, 1 or 2 degrees. Figure 4 shows the observer's pull handle.

The linear accelerations about all three axis and the pitch rate were recorded on an oscillograph. The sensitivity of the instrumentation was sufficient in the sense that the "noise" caused by small waves and by the engine was easily recorded. Three 16 mm GSAP (gun) cameras recorded the motions of the forward hydrofoil, the right aft hydrofoil, and the bow (with respect to the horizon). The splash protecting cover for the forward hydrofoil camera is visible in Figure 3 just under the bow and the bow camera is shown in Figure 4. No photo is available of the aft hydrofoil camera which was mounted on the outside of the right gunnel. The cameras all operated at approximately 16 frames/sec., the exact rate being determined from shots of a stop watch. By knowing the geometry of the boat, the camera data was reduced to give the apex submergence of the hydrofoils and the pitch angle of the boat. The intersection of the water surface with the leading edge of the hydrofoil was easily determined from the break in the leading edge line caused by the refraction of water as can be seen in Figures 5 and 6 which are typical frames from the 16 mm film. Again, the sensitivity was sufficient to pick up "noise" except for the bow camera which was sensitive to about 0.1 degree. The lateral directional parameters were not reduced but were observed to be sure that only the longitudinal motions were excited.

An approximate correlation in time between the oscillograph and the cameras was based on the moment when the washers were pulled for a step input (observable on the oscillograph and on the forward hydrofoil camera). A better correlation was then applied by integrating the pitch rate from the oscillograph and comparing it with the pitch angle from the bow camera. Since all cameras were operated by the same switch, a knowledge of the film speed from the stop watch shots permitted the time to be correlated between all the cameras. It is estimated that the maximum error is two frames, or approximately 1/8 second.

The weight, center of gravity and moment of inertia were obtained by conventional test methods. The setup for the "bounce" test for inertia is shown in Figure 7. Soft springs were fastened to either side of the transom as shown in the figure. The boat was excited into an oscillation around a pivot slightly forward of the center of gravity. The reduction of the data is not discussed here, but can be found in the Reference 1 report by Connors.

Figures 8, 9 and 10 are time histories of three runs. The test speeds are given in Table 3 along with the reference areas and lengths for non-dimensionalizing the equations of motion. These runs were conducted by setting up the desired speed,

FINAL REPORT
LR/16112

TESTS (Cont'd.)

actuating the instrumentation switches and then applying the step input. The results are as follows:

1. The boat had a tendency to oscillate in roll apparently due to ventilation. Figure 6 illustrates leading edge ventilation visible within a few inches of the water surface. This tendency, although it only had a small effect on the overall handling characteristics, did make it difficult to precisely stabilize the boat before and after a run.
2. The vertical acceleration clearly indicates that transients existed for as long as 0.2 seconds after the observer's handle was pulled. The deviation from a pure input was apparently caused by structural responses and by an uneven release of the washers. The transients were a considerable percentage of the short term boat responses. They could not, however, have been shortened without excessive effort.
3. One-half, 1 and 2 degree step inputs were tried. The 1 degree input was chosen as a compromise between the small variations in parameters caused by the $\frac{1}{2}$ degree input and the tendency towards diving caused by the 2 degree step.
4. The water surface had to be practically glassy smooth for the wave disturbances to be reduced to a tolerable level. In this connection, the choice of Morris Dam was fortunate inasmuch as it is reasonably free of wind and man-made disturbances. The lake is in a canyon and closed to the public. In spite of apparently calm conditions, however, a disturbance occurred on the run of Figure 10 which caused a decrease in forward hydrofoil submergence just as the input was applied.
5. The thrust, and hence the drag, was readily calculated from the atmospheric pressure and temperature and from a static thrust calibration. The drop in thrust with velocity was negligible as shown by the engine curves supplied by the manufacturer.
6. Long term responses were not obtained. The boat usually settled at the stern in about a second and hence speed stability could not be analyzed.

DISCUSSION

Both the computer and the test time histories are plotted in Figures 8, 9 and 10. The computer results are from the non-linear equations. Computer time histories for various conditions are compared in Figure 11 with the time history for Test 36, Run 1, the "best" of the three runs reported here. The calculations were made on a Beckman EASE Analog Computer Machine by the Control and Guidance Analysis Department following standard procedures. The following conditions were computed:

1. Linear equations:
 - a. Lift, drag and moment equations all included. Force coefficients

DISCUSSION (Cont'd.)

calculated by a Wadlin (References 3, 4) method. Table 4 provides a list of the force coefficients and derivatives along the flow axes as well as geometric constants.

- b. Lift and moment equations only. The drag is assumed to remain constant.
 - c. Same as (b) except the lift coefficients are calculated by a method given in the Gibbs and Cox Hydrofoil Handbook (Reference 5).
2. Non-linear equations:
- a. Lift and moment equations only. Drag remains constant. Lift coefficients again calculated by the Wadlin method.

Refer to Figure 11. It is apparent that the correlation between theory and test is fair for pitch angle but poor for depth of submergence. Furthermore, it is apparent that although there is some variation between the different computer solutions, it does not account for the variation between theory and experiment. Of all the computer solutions, the non-linear equations, although the simplest in concept, come closer to the test values. The question now arises as to why the computer solutions correlated so poorly with the test. Unfortunately, a positive answer cannot be given as the program was time and expenditure limited and a detailed investigation of the problem was beyond its scope. It is suggested, however, that the discrepancy is caused by partial and full chord ventilation. The following considerations are listed.

1. The 16 mm films reveal leading edge ventilation on the aft hydrofoil on Test 35, Run 4 and Test 36, Run 2. No leading edge ventilation was observed on Test 36, Run 1. Full chord ventilation was never observed on the forward hydrofoil on these or any other tests. Also, partial chord ventilation was never observed on either hydrofoil, but unlike full chord ventilation, it might occur and escape detection (refer to Figures 5, 6).
2. Other effects such as downwash, etc., appear to be small or do not affect the boat responses at the relatively slow rates existing after the first few tenths of a second.

As a result of these considerations, it is suggested that partial chord ventilation occurred on both the forward and aft hydrofoil. No attempt was made to account for ventilation in theory because of its erratic nature. Such a discrepancy between theory and test was not observed on model tests by Wetzel (Reference 6). His tests, at a speed of 10 ft/sec. may not be representative of the ventilation conditions on a full scale vehicle. The Reynolds number simulation was particularly poor.

RECOMMENDATIONS

It is recommended that a program be initiated to determine how stability theory can be applied to full scale, surface piercing hydrofoil boats. Stability experiments on various configurations would determine whether or not the difficulties recorded here were unique. Ventilation should be observed and its nature noted under a variety of boat configurations and test conditions.

REFERENCES

1. Connors, Joseph L., Correlation between Simulated and Measured Performance of the Gibbs and Cox Twenty-Foot Variable - Incidence Hydrofoil Craft, Flight Control Laboratory, Massachusetts Institute of Technology, Report FCL-7203-R11, May 1955.
2. Chuck, G., Luke, R.K.C., and Scroggs, S.F., Study of Hydrofoil Stability and Control, Hughes Aircraft Company, Report SRS-399, ASTIA AD-250431, 29 December 1960.
3. Wadlin, Kenneth L. and Christopher, Kenneth W., A Method for Calculation of Hydrodynamic Lift for Submerged and Planning Rectangular Lifting Surface, NASA Technical Report R-14, 1959.
4. Wadlin, Kenneth L., Shuford, Charles L. Jr. and McGehee, John R., A Theoretical and Experimental Investigation of the Lift and Drag Characteristics of Hydrofoils at Subcritical and Supercritical Speeds, NACA Report 1232, 1955.
5. Michel, W. H., Hoerner, S. F., Ward, L. W. and Buermann, T. M., Hydrofoil Handbook, Volume II, Hydrodynamic Characteristics of Components, Gibbs and Cox, Inc., ASTIA AD-89681, 1954.
6. Wetzel, J. M., Experimental and Analytical Studies of the Longitudinal Motions of a Tandem Dihedral Hydrofoil Craft in Regular Waves, St. Anthony Falls Hydraulic Laboratory, University of Minnesota, Technical Paper No. 30, Series B, April 1962.

SYMBOLS

C_D	Coefficient of drag	}	Based on horizontal projected area
C_L	Coefficient of lift		
C_M	Coefficient of moment around Y axis		
C_x	Coefficient of force along X axis		
C_z	Coefficient of force along Z axis		

$$C_{xh} = \frac{\partial C_x}{\partial (h/\ell)}$$

$$C_{xq} = \frac{\partial C_x}{\partial q}$$

$$C_{xu} = \frac{\partial C_x}{\partial (u/v)}$$

$$C_{x\alpha} = \frac{\partial C_x}{\partial \alpha}$$

$$C_{x\theta} = \frac{\partial C_x}{\partial \theta}$$

Likewise for C_D , C_L ,
 C_M and C_z

$$d(\) = \frac{d(\)}{d\tau}$$

d	Apex submergence of hydrofoil, positive down
g	Acceleration of gravity
h	Perturbation height of center of gravity, positive up
I	Test moment of inertia of boat
ℓ	Reference length between center of pressures on forward and aft hydrofoil
m	Test mass of boat
q	$\frac{d\theta}{d\tau}$
r_y	radius of gyration around Y axis

SYMBOLS (Cont'd.)

S Reference area: Horizontal projected area of hydrofoil or vertical area of rudder (underwater area only)

$$S_d = \frac{\partial S}{\partial (a/l)}$$

$$S_t = S_f + S_a$$

t Time

u Perturbation velocity along X axis

V Initial velocity of boat

x Distance along X axis between center of pressure of hydrofoil and center of gravity

z Distance along Z axis between center of pressure of hydrofoil and center of gravity

α Angle of attack

θ Pitch angle

$$\mu = \frac{m}{\rho S l}$$

ρ Density of water

$$\tau = \frac{tV}{l}$$

Subscripts

()_a - Aft hydrofoil

()_f - Forward hydrofoil

()_o - Initial condition

LINEARIZED EQUATIONS OF MOTION

Drag equation:

$$(C_{xu} - 2\mu/d) u/v + C_{x\alpha} \alpha + (C_{x\theta} - C_w + C_{xq} d) \theta + C_{xh} h/l = 0$$

Lift equation:

$$C_{zu} u/v + (C_{z\alpha} - 2\mu/d) \alpha + (C_{z\theta} + C_{zq} d + \partial\mu/d) \theta + C_{zh} h/l = 0$$

Moment equation:

$$C_{Mu} u/v + C_{M\alpha} \alpha + (C_{M\theta} + C_{Mq} d - 2\mu \left(\frac{r_y}{l}\right)^2 d^2) \theta + C_{Mh} h/l = 0$$

Kinematic condition:

$$\alpha - \theta + d(h/l) = 0$$

NON-LINEAR EQUATIONS (CONSTANT DRAG)

Lift equation:

$$m \left(\frac{d^2 h}{dt^2} + g \right) = \left[\dot{C}_{L\alpha}(d) S(d) \alpha \right]_f \frac{1}{2} \rho v^2 + \left[C_{L\alpha}(d) S(d) \alpha \right]_a \frac{1}{2} \rho v^2$$

Moment equation:

$$I \frac{d^2 \theta}{dt^2} = \left[C_{L\alpha}(d) S(d) x \right]_f \frac{1}{2} \rho v^2 + \left[C_{L\alpha}(d) S(d) x \right]_a \frac{1}{2} \rho v^2$$

Kinematic condition for forward or aft hydrofoil:

$$\alpha = - \frac{dh/dt}{v} - x \frac{d\theta/dt}{v} + \theta + \theta_0 + \alpha_0$$

$$d = -h - x\theta + d_0$$

TRANSFORMS OF STABILITY DERIVATIVES FROM FLUID AXES TO BODY AXES

$$C_{x_u} = -C_{D_u} - 2C_D$$

$$C_{x_\alpha} = C_L - C_{D_\alpha}$$

$$C_{x_h} = C_{D_d} + C_D \frac{S_d}{S}$$

$$C_{x_\theta} = \frac{x}{l} C_{x_h}$$

$$C_{x_q} = \frac{z}{l} C_{x_u} - \frac{x}{l} C_{x_\alpha}$$

$$C_{z_u} = -C_{L_u} - 2C_L$$

$$C_{z_\alpha} = -C_{L_\alpha} - C_D$$

$$C_{z_h} = C_{L_d} + C_L \frac{S_d}{S}$$

$$C_{z_\theta} = \frac{x}{l} C_{z_h}$$

$$C_{z_q} = \frac{z}{l} C_{z_u} - \frac{x}{l} C_{z_\alpha}$$

$$C_{M_u} = \frac{z}{l} C_{x_u} - \frac{x}{l} C_{z_u}$$

$$C_{M_\alpha} = \frac{z}{l} C_{x_\alpha} - \frac{x}{l} C_{z_\alpha}$$

C_{M_h} , C_{M_θ} and C_{M_q} are similar to C_{M_u} and C_{M_α}

NOTE: Summation not indicated. Multiply derivatives for individual hydrofoil by ratio of its area to total area before summing.

FINAL REPORT
LR/16112

BASIC DATA

Hull:

Type	Catamaran
Model	60-18
Manufacturer	Power Cat Boat Corporation
Length, Overall	17 ft.
Beam	8 ft.

Powerplane:

Type	Turbojet Engine
Model	J44R-24
Manufacturer	Fairchild Engine and Airplane Corp.
Maximum Thrust	1000 lbs.

Weight and Balance:

Test Weight	2615 lbs.
Center of Gravity:	
Distance forward from Bottom Edge of Transom	69 in.
Distance above Bottom of Boat - (estimated)	19 in.
Radius of Gyration about Lateral Axis thru the Center of Gravity	57 in.

Test Speeds:

Test 35, Run 4	26.5 knots
Test 36, Run 1	26.5 knots
Test 36, Run 2	30 knots

Reference Hydrofoil Areas (Initial Wetted Projected Areas):

	<u>Forward Hydrofoil</u>	<u>Both Aft Hydrofoil</u>
Test 35, Run 4	Not available	540 sq. in.
Test 36, Run 1	448 sq. in.	519 sq. in.
Test 36, Run 2	357 sq. in.	420 sq. in.

Reference Length (Distance between 25% Chord Lines) 129.3 in.

FINAL REPORT
LR/16112

BASIC PARAMETERS FOR TEST 36, RUN 1

	Forward <u>Hydrofoil</u>	Aft <u>Hydrofoil</u>	<u>Rudder</u>
	<u>Geometric Constants</u>		
s/s_t	0.464	0.536	0.368
s/s_w	0.893	0.730	1.000
s_d/s	8.76	11.2	13.3
x/l	0.433	-0.567	-0.617
z/l^2	0.291	0.251	0.239

FORCE COEFFICIENTS AND DERIVATIVES
(Wadlin's Method)

c_L	0.275	0.1325	0
c_D	0.0393	0.0271	0.015
$c_{L\alpha}$	2.61	2.63	0
c_{Ld}	1.90	0.67	0
c_{Lu}	0	0	0
$c_{D\alpha}$	0.096	0.102	0
c_{Dd}	0.022	0.011	0
c_{Du}	0	0	0

TABLE 4

PREPARED	NAME <i>[Signature]</i>	DATE 6 June '62	LOCKHEED AIRCRAFT CORPORATION CALIFORNIA DIVISION	PAGE
CHECKED			TITLE:	MODEL
APPROVED				REPORT NO.

FORWARD HYDROFOIL

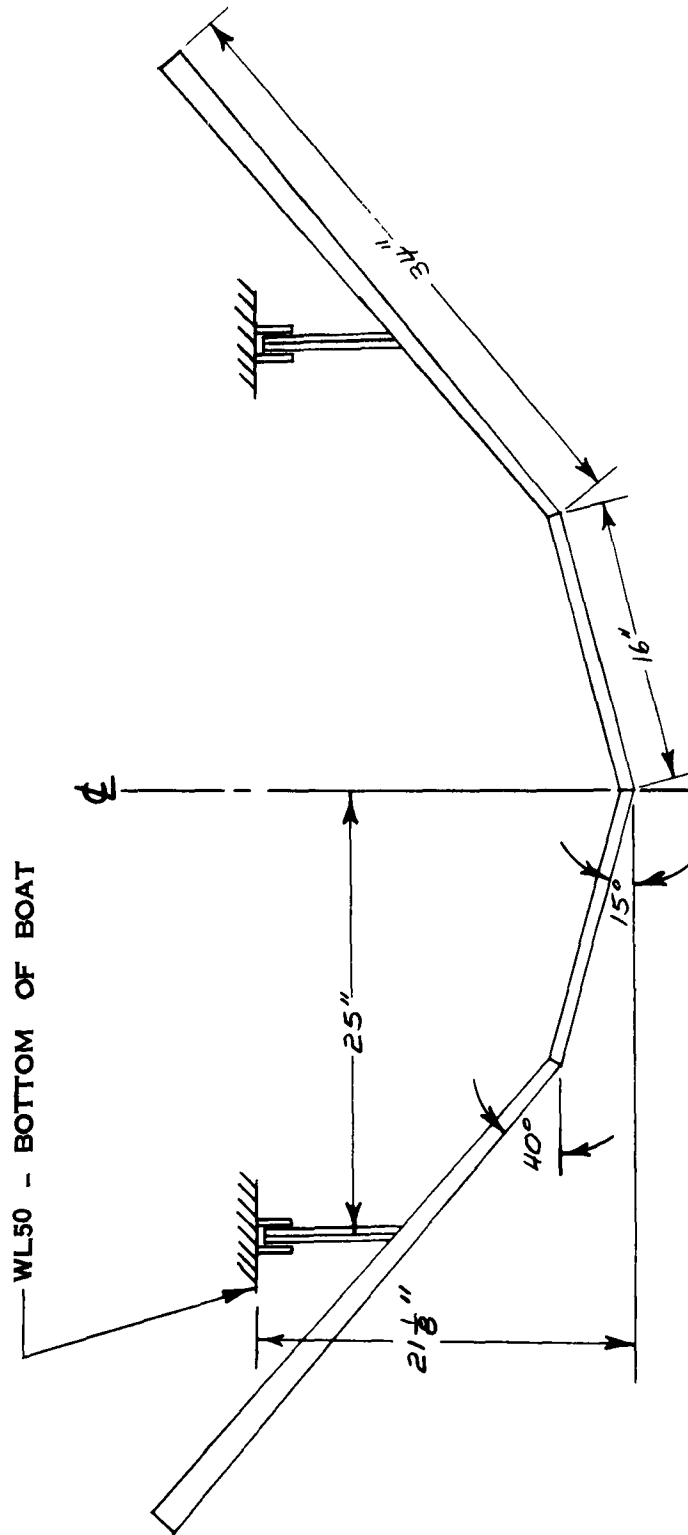

CENTER PANELS: RECTANGULAR, 10 IN. CHORD
 OUTBOARD PANELS: UNIFORM INVERSE TAPER, 10 TO 20 IN. CHORD
 STRUTS: RECTANGULAR, 10 IN. CHORD
 THICKNESS: FOIL 8% OF CHORD, STRUTS 8.7% CHORD
 FOIL SECTION: CIRCULAR ARCS TOP, FLAT PLATES BOTTOM
 STRUT SECTION: CIRCULAR ARCS BOTH SIDES

Figure 1

PREPARED	NAME <i>Lox</i>	DATE <i>June '62</i>	LOCKHEED AIRCRAFT CORPORATION CALIFORNIA DIVISION	PAGE
CHECKED			TITLE:	MODEL
APPROVED				REPORT NO.

FRONT VIEW OF LEFT AFT HYDROFOIL

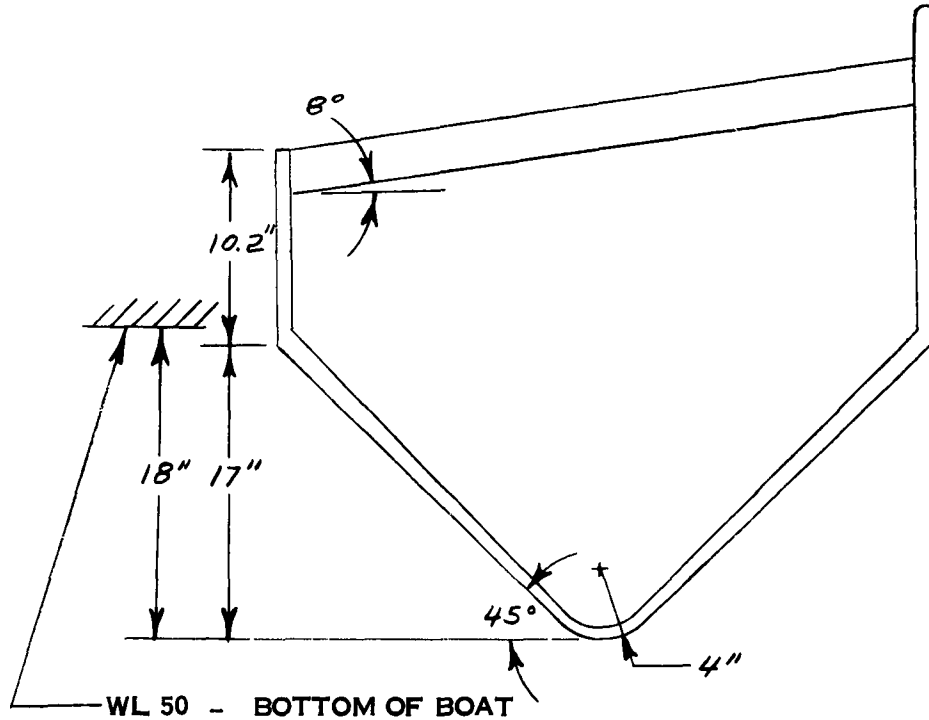

LIFTING SECTION OF AFT HYDROFOIL LAID OUT FLAT

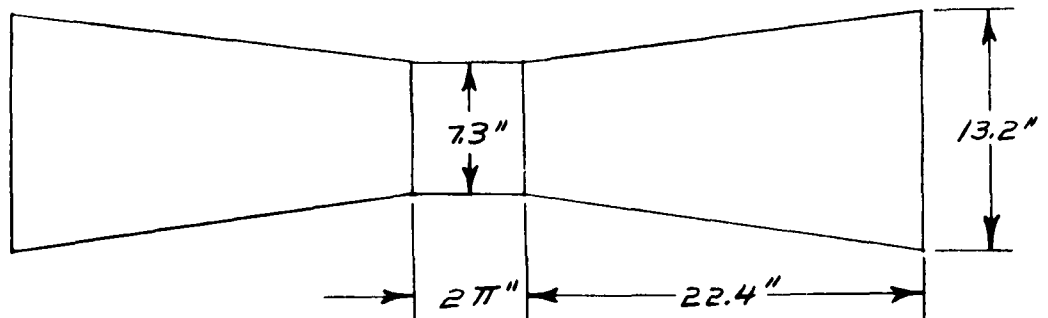

APPROXIMATE SECTION PARAMETERS:

MAXIMUM THICKNESS	8.9% OF CHORD
MAXIMUM CAMBER	1.5% OF CHORD
LEADING EDGE RADIUS	4.2% OF CHORD

Figure 2

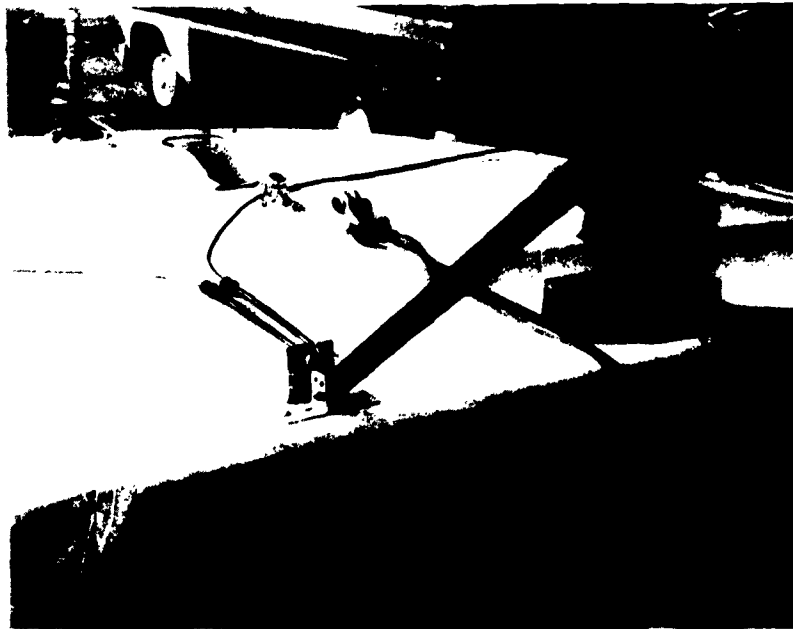
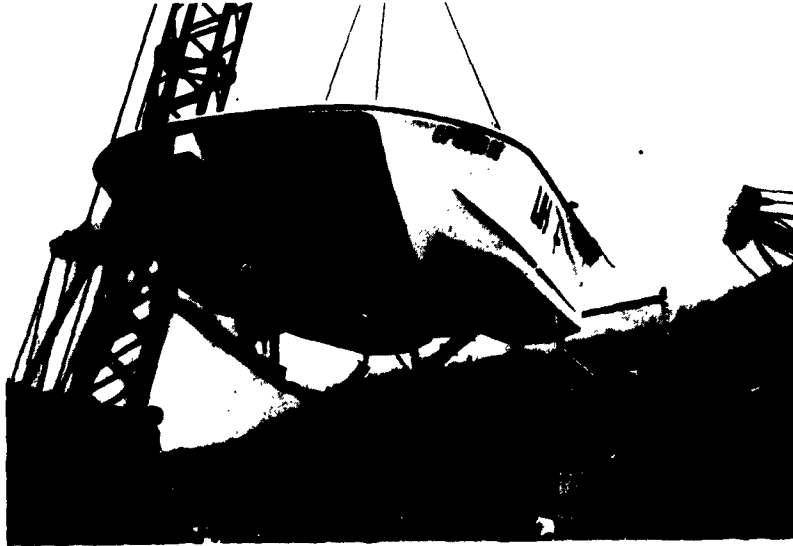

Figure 3 (Top) - View of Hydrofoil Configuration

Figure 4 (Bottom) - Observer's "pull-handle" and Bow Camera



Forward Hydrofoil In Flight

Figure 5



Aft Hydrofoil In Flight

Figure 6

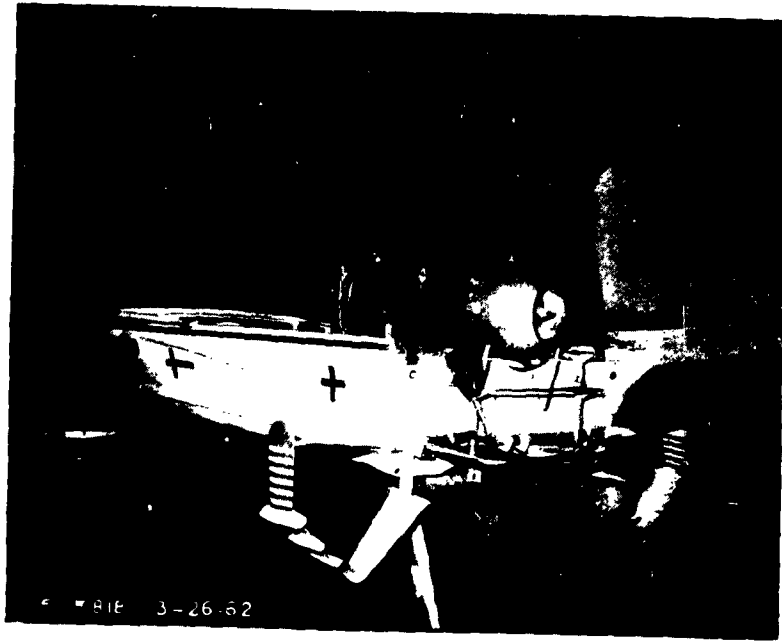

Setup for "Bounce" Test

Figure 7

LOCKHEED LH-2 HYDROFOIL BOAT
TRANSIENT LONGITUDINAL STABILITY
TEST 95 RUN # DATE 3-5-62

NON LINEAR EQUATIONS
TEST

NOTE: FORWARD FOIL APEX SUBMERGENCE
NOT AVAILABLE

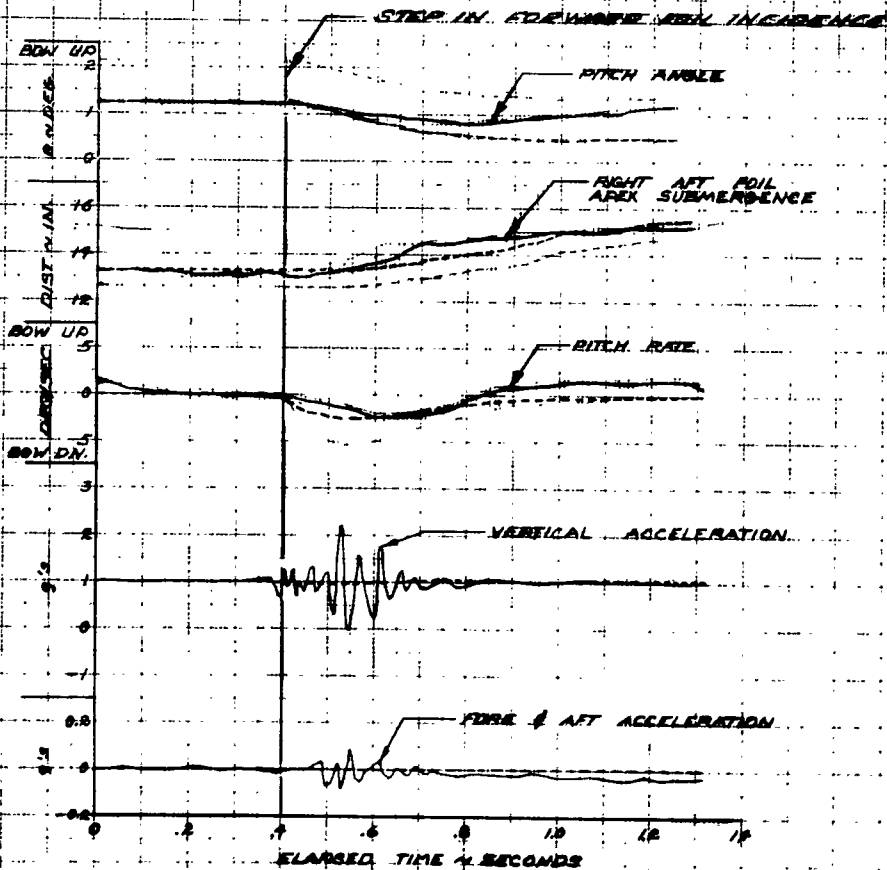

PREPARED BY *RLM*
DATE *5-2-62*
CHECKED BY *RLM*

LOCKHEED CALIFORNIA COMPANY
A DIVISION OF LOCKHEED AIRCRAFT CORPORATION

FILE NO. _____
MODEL NO. _____
REPORT NO. _____

FIGURE B

FINAL REPORT
 LR/1812
 LOCKHEED LM-8 HYDROFOIL BOAT
 TRANSIENT LONGITUDINAL STABILITY
 TEST 26 DATE: 8-3-68
 RUN 1

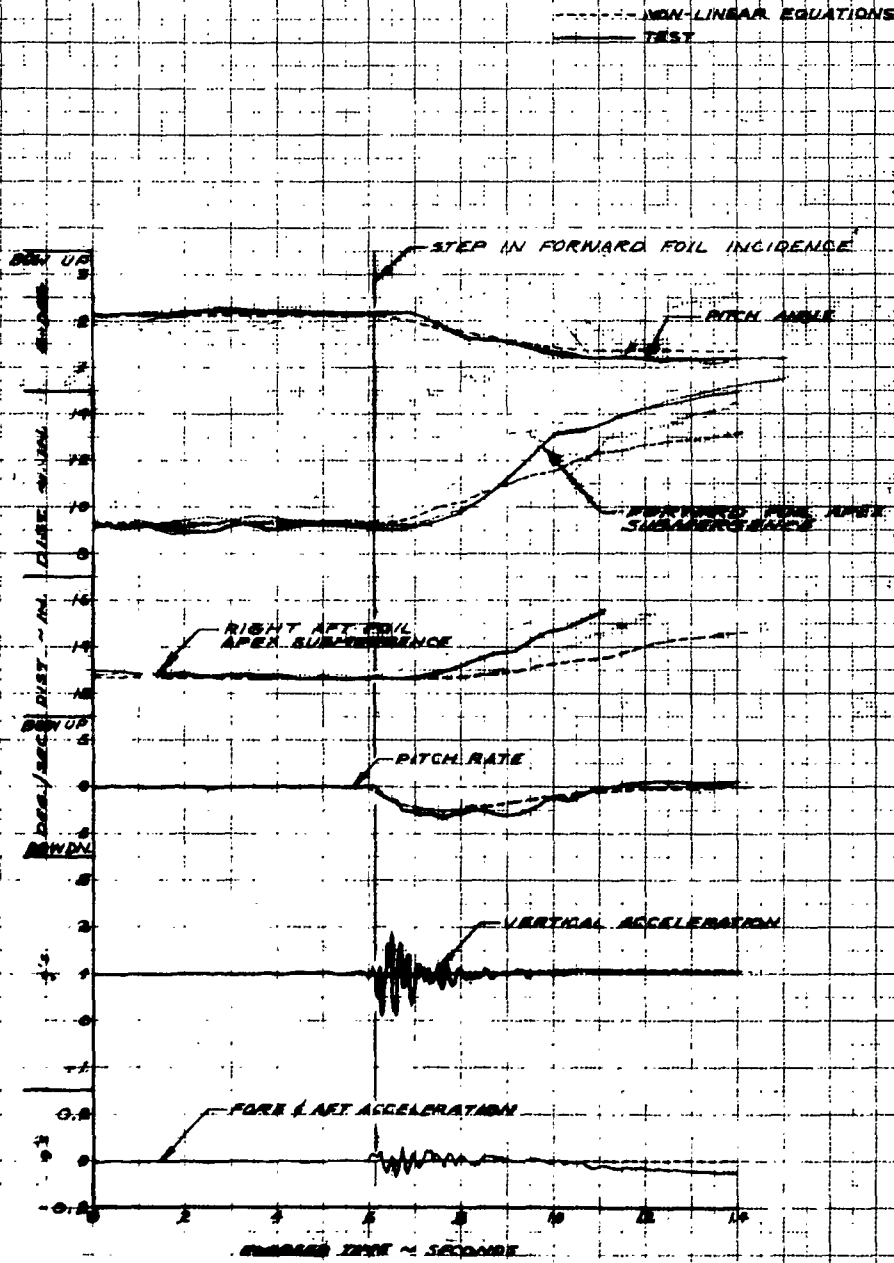

PREPARED BY: *BLANKA*
 DATE: 8-13-68
 CHECKED BY: *BLANKA*

LOCKHEED-CALIFORNIA COMPANY
 A DIVISION OF LOCKHEED AIRCRAFT CORPORATION

PROJECT NO.:
 REPORT NO.:

FIGURE 9

FINAL REPORT
LR/1612

Lockheed LH-2 Hydrogen-Bomb
TRANSIENT LONGITUDINAL STABILITY
Test 35 Run 2 Dated 2-7-62

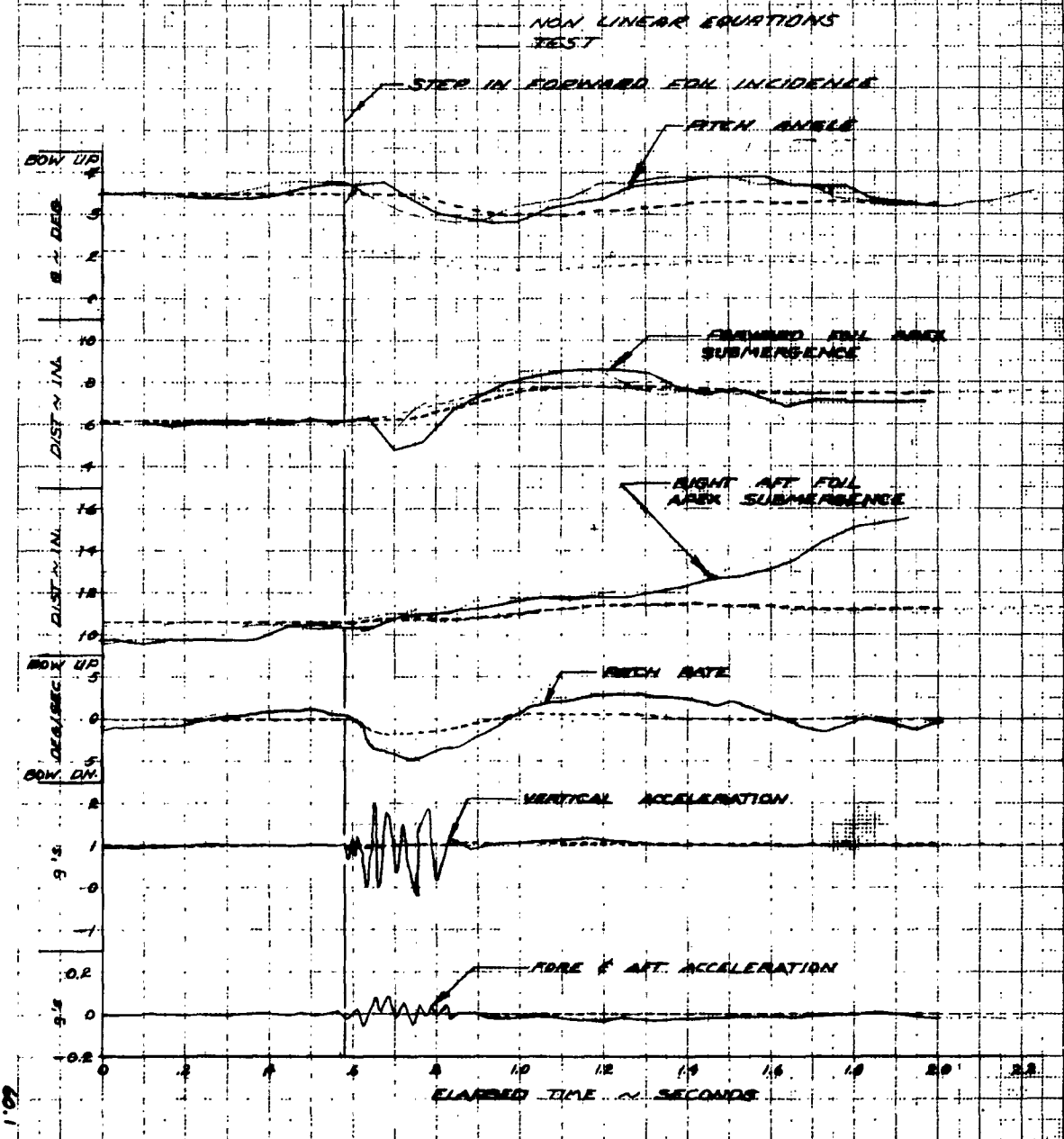

PREPARED BY: DLM
DATE: 2-1-62
CHECKED BY: MJB

LOCKHEED-CALIFORNIA COMPANY
A DIVISION OF LOCKHEED AIRCRAFT CORPORATION

MODEL:
REPORT NO:

FIGURE 10

LOCKHEED LH-2 HYDROFOIL BOAT
 TIME HISTORY COMPARISON
 TEST 36 RUN 1 7 FEB. 1962

_____ WADLIN WITH CONSTANT DRAG
 _____ WADLIN WITH DRAG EQUATION
 _____ GIBBS & COX WITH CONSTANT DRAG
 _____ WADLIN'S NON-LINEAR EQUATIONS
 _____ TEST

} LINEAR EQUATIONS

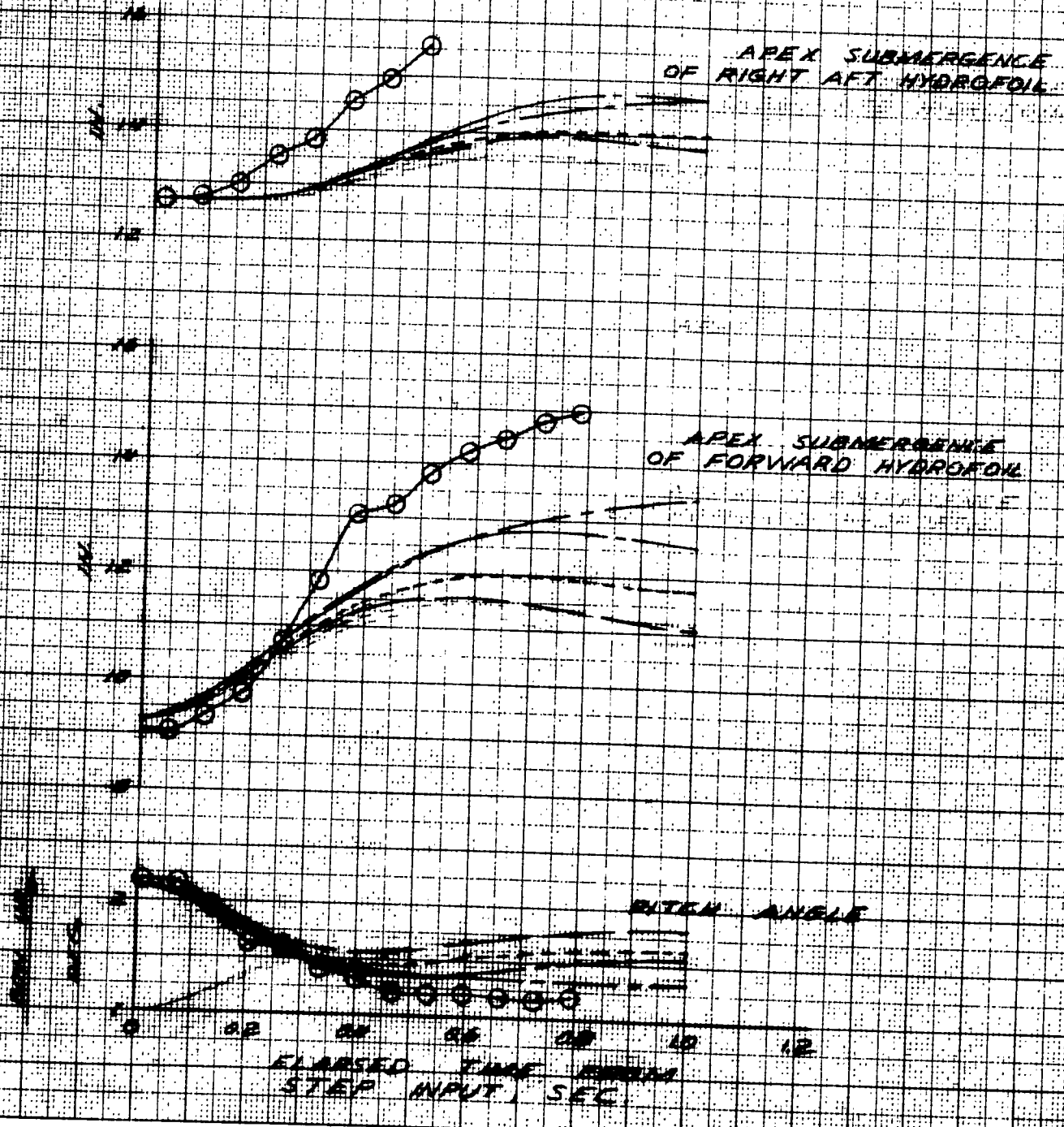

Figure 11