

UNCLASSIFIED

AD 297 055

*Reproduced
by the*

**ARMED SERVICES TECHNICAL INFORMATION AGENCY
ARLINGTON HALL STATION
ARLINGTON 12, VIRGINIA**



UNCLASSIFIED

NOTICE: When government or other drawings, specifications or other data are used for any purpose other than in connection with a definitely related government procurement operation, the U. S. Government thereby incurs no responsibility, nor any obligation whatsoever; and the fact that the Government may have formulated, furnished, or in any way supplied the said drawings, specifications, or other data is not to be regarded by implication or otherwise as in any manner licensing the holder or any other person or corporation, or conveying any rights or permission to manufacture, use or sell any patented invention that may in any way be related thereto.

2-923

297 055

AFCL - 62 - 923

A QUANTITATIVE STUDY OF THE EVOLUTION OF
GASES FROM ELECTRON TUBES AND MATERIALS

W. J. Grubbs, G. H. Snider and F. I. Scott
E. I. DOUCETTE ASSOCIATES, INC.
246 Main Street
Chatham, N.J.

AF19(628)-326
Project #4619
Task #46190

Third Scientific Report

Period Covered
June 18, 1962 to September 18, 1962

Report Submitted: October 31, 1962

Prepared for

ELECTRONICS RESEARCH DIRECTORATE
AIR FORCE CAMBRIDGE RESEARCH LABORATORIES
OFFICE OF AEROSPACE RESEARCH
UNITED STATES AIR FORCE
BEDFORD, MASSACHUSETTS

Requests for additional copies by Agencies of the Department of Defense, their contractors, and other Government agencies should be directed to the:

ARMED SERVICES TECHNICAL
INFORMATION AGENCY
ARLINGTON HALL STATION
ARLINGTON 12, VIRGINIA

Department of defense contractors must be established for ASTIA services, or have their "need-to-know" certified by the cognizant military agency of their project or contract. All other persons or organizations should apply to the

U. S. DEPARTMENT OF COMMERCE
OFFICE OF TECHNICAL SERVICES
WASHINGTON 25, D. C.

TABLE OF CONTENTS

	Page
Abstract-----	3
Introduction-----	4
New Omegatron Calibration-----	6
Construction of the Gas Analysis System-----	11
Orifice Conductance Calibration-----	14
Determination of Quantities of Gases Evolved-----	22
Preliminary Degassing of Amperex Tube-----	31
Appendix I-----	33
Appendix II-----	34

ABSTRACT

The following is the third quarterly report of work now in progress which is aimed at achieving a higher degree of reliability in electron tubes through a better and more comprehensive understanding of the kinds and quantities of gases which occur in these tubes. A bakeable, ultraclean high vacuum system which incorporates an omegatron mass spectrometer has been constructed for conducting these investigations. Essentially all of the effort during this report period has been devoted to the construction and calibration of the various orifice systems utilized in the equipment. The results obtained and detailed in this report indicate that the objectives of the study can in fact be achieved and work is currently progressing in this direction. Some preliminary degassing experiments are described.

INTRODUCTION

In this report, the Third Quarterly Report in the Quantitative Study of Gas Evolution from Electron Tubes, the new vacuum system construction is shown, the omegatron gauge calibration data are presented, and the orifice conductance calibrations are described. Some observations of the preliminary degassing of the tube to be studied in detail (Amperex Type 5894) are reported and the specific tests to be performed on this tube during the next period are outlined.

The two previous reports have presented the background of the study, emphasizing the vital need for quantitative information regarding gas evolution and reaction rates. In fact, significant advances in the preparation of materials and in the development of optimum processing techniques cannot be made without such information. To this end, and in view of the small quantities of gas involved and the complexity of the tube gas interactions, considerable care has been exercised in the design, construction, and calibration of the system and associated equipment. The six ion gauges were completely calibrated for the five gases expected to occur in significant quantities: hydrogen, carbon monoxide, carbon dioxide, nitrogen, and methane, as well as the test gas deuterium, on a specially constructed high vacuum system. (The hydrogen and deuterium calibrations are included in the present report.)

During the extensive omegatron calibration procedure, the carbon monoxide pumping action of the ion gauges was evaluated. The lack of a detectable ion current in the omegatron for most of the masses when using an RF signal of only 1 volt rms, led to an investigation of the magnetic field uniformity. Variations were monitored along the vertical diameter of the pole faces using an indium antimonide magnetoresistor. After many modification attempts, a simple shim

proved most effective in minimizing field variations. (See Quarterly Report No. 2.) The increased field uniformity permitted the use of an RF signal of 1.5 volts rms. and a beam current of 1.0 microamperes but required recalibration of the omegatron gauge.

NEW OMEGATRON CALIBRATION

Following the improvement in magnetic field uniformity achieved in the Second Quarterly Report, it was necessary to obtain new calibration data for the omegatron. The operating conditions used were:

E_f	Filament Bias	-70 VDC
E_c	Collector Bias	20 VDC
E_t	Trap Bias	1.4 VDC
I	Beam Current	1.0 uamp
E_{RF}	RF Voltage	1.5 V_{rms}

Data obtained for the six gases, CH_4 , CO_2 , CO , N_2 , D_2 and H_2 are plotted as sensitivity (ma/ma/Torr) vs. pressure in Torr in Figures 1, 2, and 3. A straight line has been drawn through a proximate weighted average of points in the neighborhood of 10^{-6} Torr pressure. As expected, the sensitivity falls sharply in the range of 10^{-5} Torr, and these points have been ignored in the averaging. The weighted average value indicated by the horizontal line will be used as the omegatron sensitivity for the particular gas. These sensitivities are:

CH_4	9.5
CO_2	4.2
CO	9.7
N_2	11.5
D_2	3.5
H_2	2.9

Agreement between these values and those reported in the literature is good except for CO_2 . The sensitivity for CO_2 is usually reported as greater

OMEGATRON SENSITIVITY DATA

DEUTERIUM

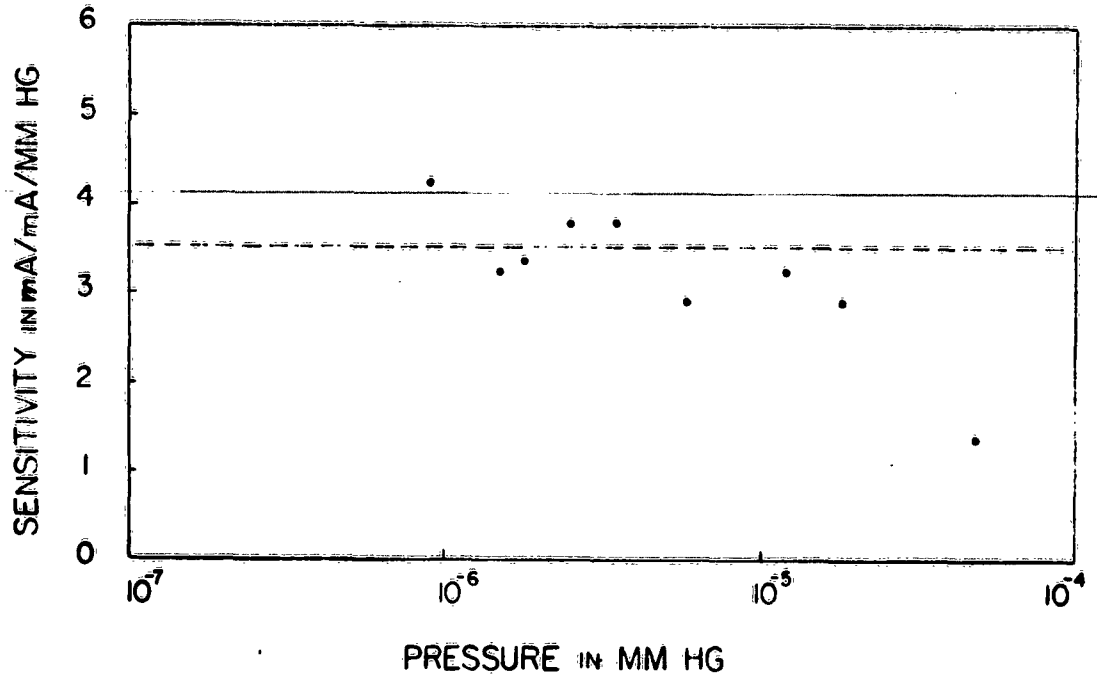

HYDROGEN

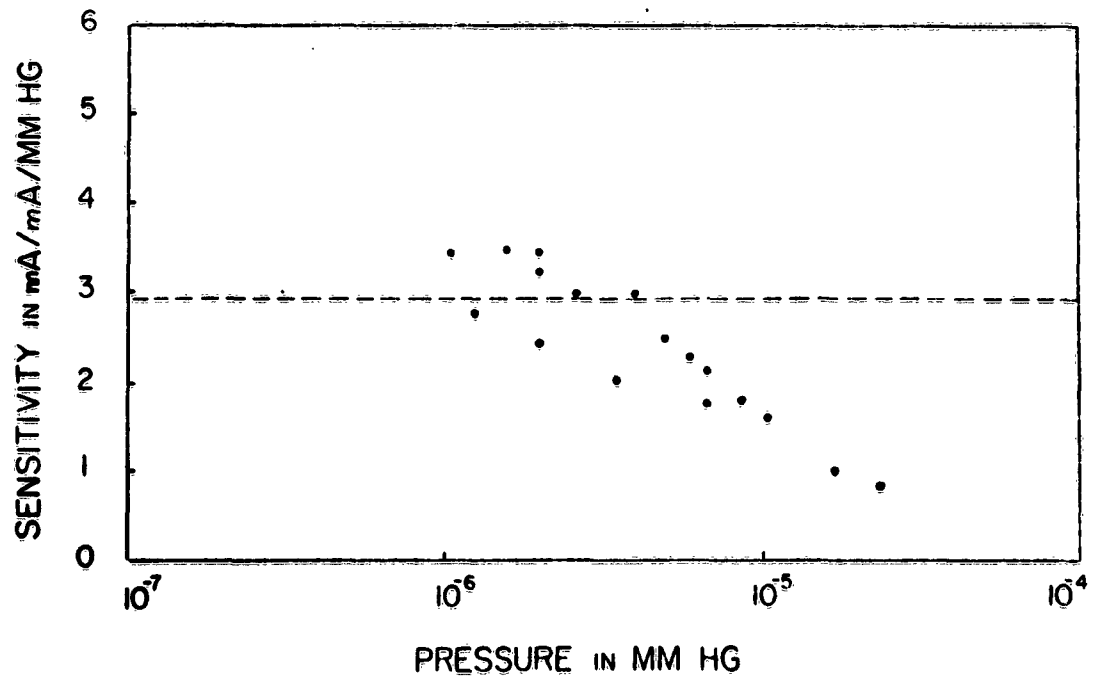
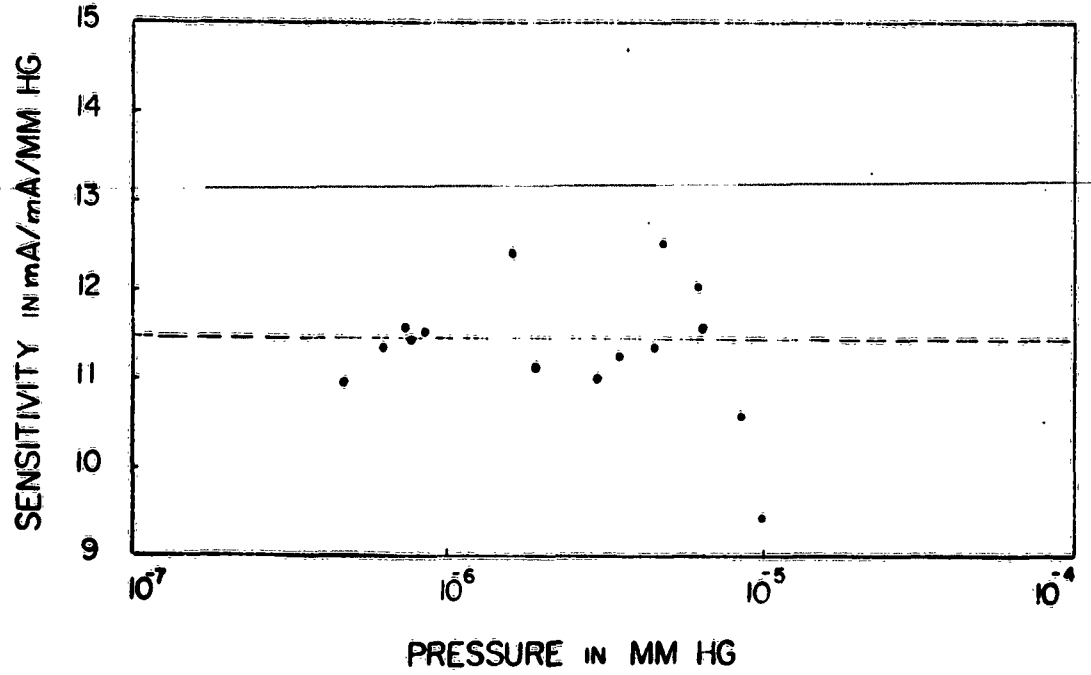

Figure 1

OMEGATRON SENSITIVITY DATA

NITROGEN



METHANE

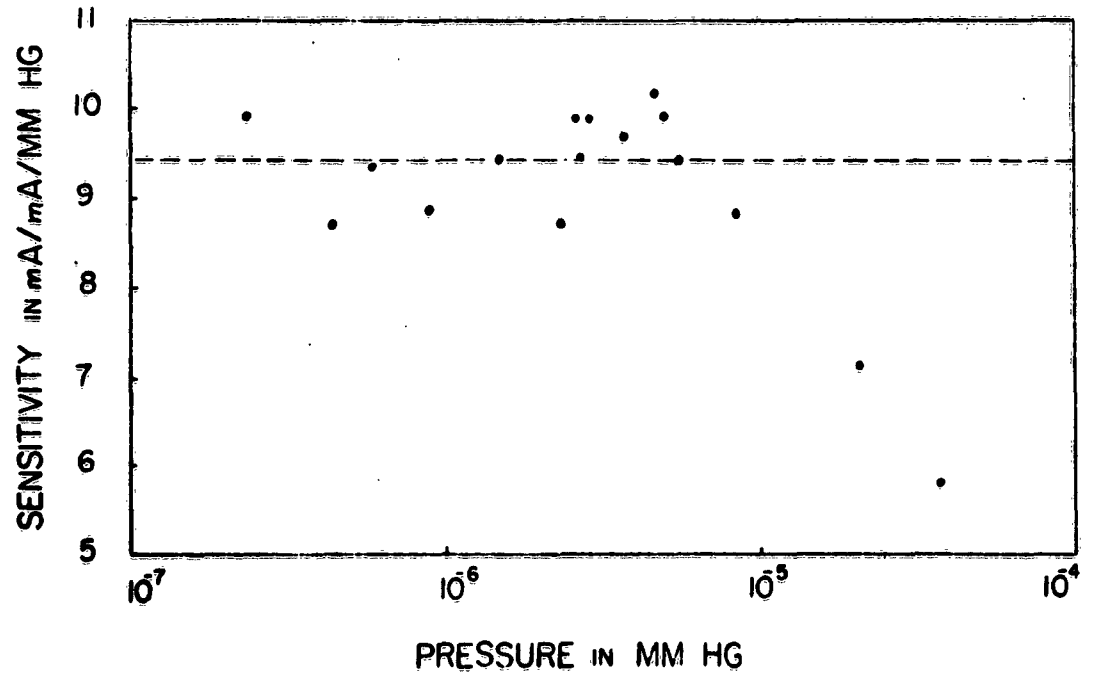
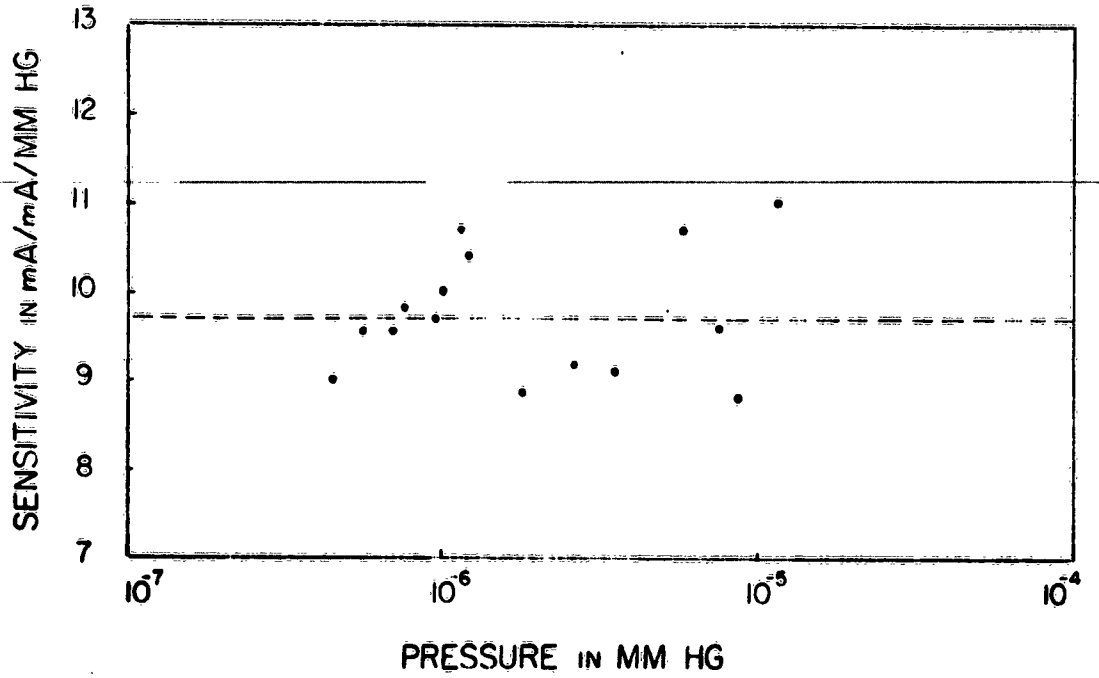

Figure 2

OMEGATRON SENSITIVITY DATA

CARBON MONOXIDE



CARBON DIOXIDE

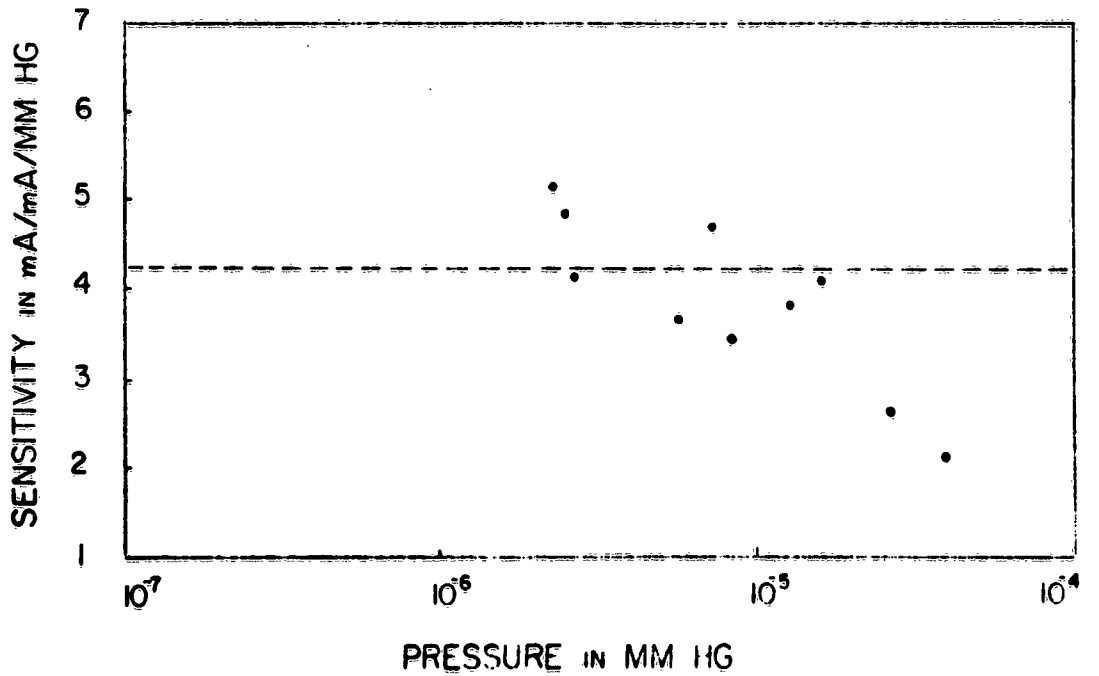

Figure 3

than that for CO as opposed to our findings. However, extensive supplemental tests with CO₂ did not result in any change of the sensitivity value. We conclude, therefore, that the measured sensitivity is accurate and free of error in experimental technique. The complete scans for the individual gases gave patterns which are comparable to those shown in the Second Quarterly Report. Table I compares the intensity of peaks at significant mass numbers to that of the main peak for each gas. (Intensity of main peak = 100).

Gas	Mass Number								
	2	4	12	13	14	15	16	28	44
CH ₄			1.5	3.85	10.3	76.9	100		
CO ₂			4.2				9.0	23.5	100
CO			3.8				1.9	100	
N ₂					7.65			100	
D ₂		100							
H ₂	100								

An unsuccessful attempt was made to calibrate the system with a known gas mixture. A small cylinder containing a helium-nitrogen mixture was attached to the system. During the preliminary calibration procedure, a leak developed in the system between the valve of the variable leak and the main chamber. Before the leak was detected, confirmed, and located, however, the cylinder was almost empty and the calibration could not be completed. In the interest of time, a decision was made to proceed with the construction of the gas analysis system and eliminate the gas mixture calibration.

CONSTRUCTION OF THE GAS ANALYSIS SYSTEM

The gas analysis system was constructed essentially as shown and described in the First Quarterly Report except for some improvements and slight changes to facilitate operation. Figure 4 is a block diagram of the system. It is identical with that of Figure 3 in the First Report with the exception that the ionization gauges P_3 and P_4 are interchanged. (The conductance equations are thereby changed from those given and they will therefore be restated when used to assure clarity).

As described in the First Report, precision bore tubing of required dimensions was used to construct the orifices. The variable leak was placed below the oven table so as to allow bakeout of the system without changing the settings. (The valve would have had to be opened completely during bakeout. A hot air gun is used in heating that portion of the system below the oven table to achieve adequate bakeout).

An improvement in the data collection system has been achieved by the addition of a switching arrangement which will allow one to record pressure readings from the six ionization gauges without interchanging leads. In the arrangement, the six gauges are connected to two rotary switches such that it is possible to read any of nine possible combinations of two gauges at a time.

A picture of the system as it now exists is given in Figure 5.

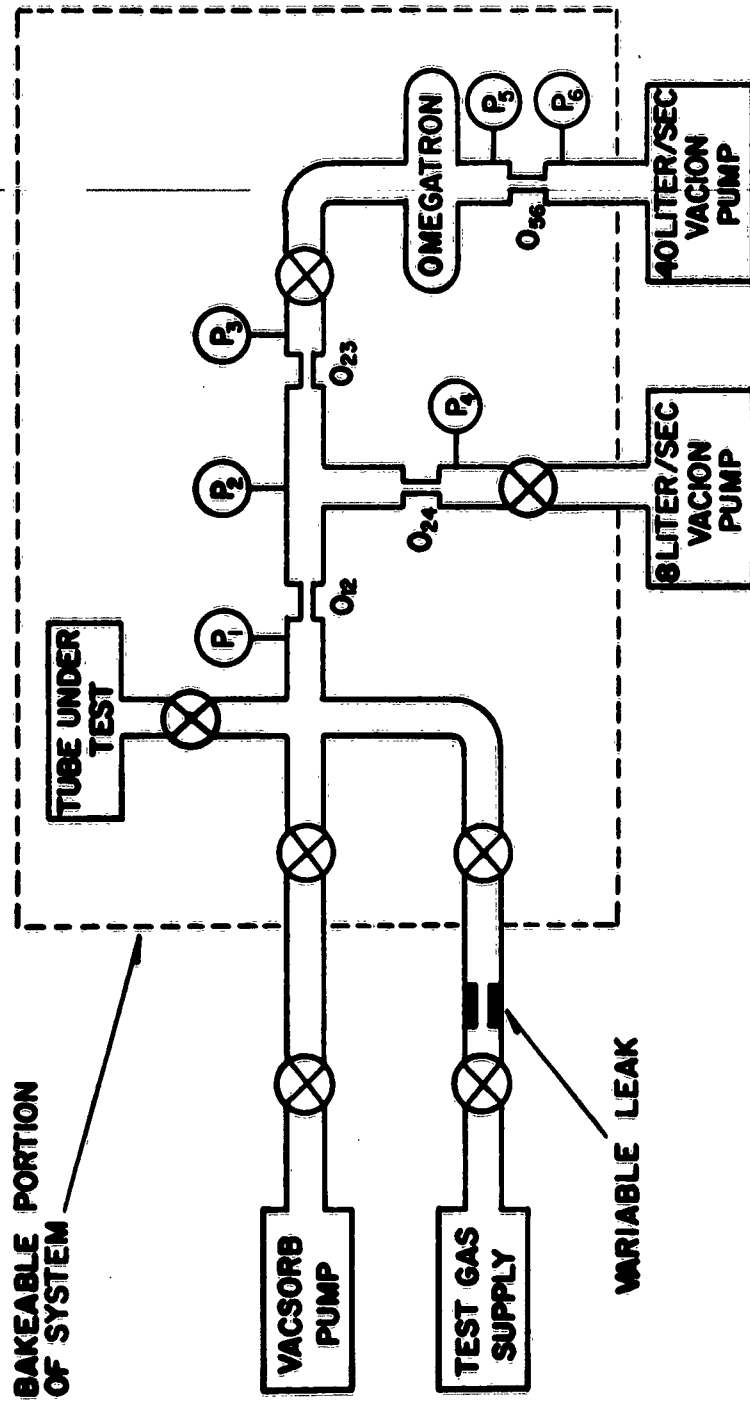
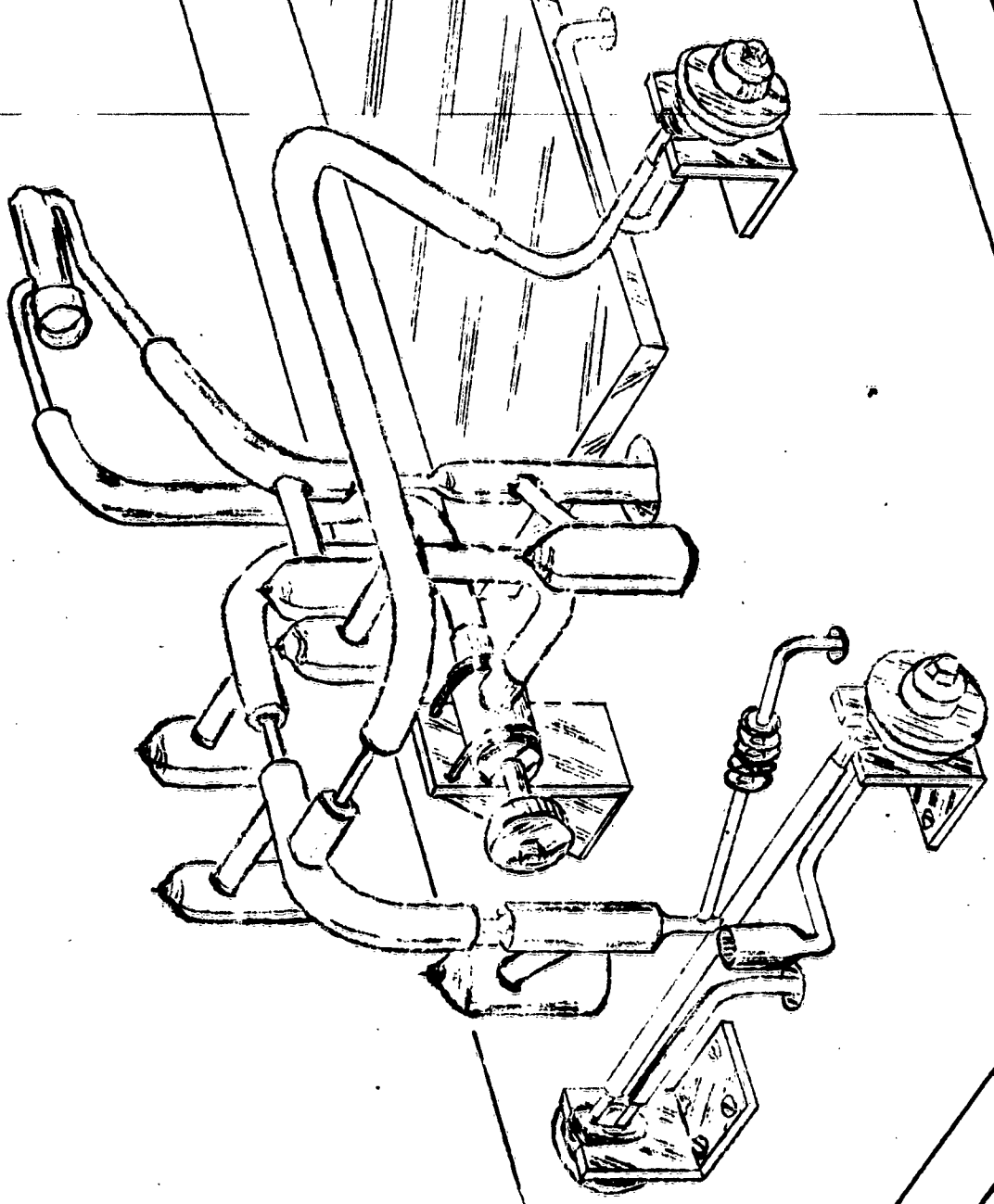

Figure 4

Fig. 5



ORIFICE CONDUCTANCE CALIBRATION

The conductance of an orifice is given by the equation:

$$C = Q/P$$

where Q is the quantity of gas passing through the orifice per unit time, and P is the pressure drop across the orifice. Similarly, the throughput of a pump is given by:

$$Q = S P$$

where S is the pumping speed in volume per unit time, and P is the pressure at the inlet of the pump.

Based on the diagram of Figure 4, the following equations apply to the orifices and pumps (the subscripts 8 and 40 refer to the 8 liter per second and 40 liter per second ion pumps):

$$C_{56} (P_5 - P_6) = Q_{40}$$

$$C_{23} (P_2 - P_3) = C_{56} (P_5 - P_6)$$

$$C_{24} (P_2 - P_4) = Q_8$$

$$C_{12} (P_1 - P_2) = C_{56} (P_5 - P_6) + C_{24} (P_2 - P_4) = Q_{40} + Q_8$$

As discussed in the Second Report, the standard leaks were not suitable for this investigation. Since the variable leak was not reproducible, we based the conductance calibration measurements on the pump speed data as reported by the pump manufacturer. The original data sheets graphically described the pump speed as being constant through the range 10^{-5} Torr to 10^{-8} Torr. After a number of experimental runs gave wide discrepancies in conductance values, the pump manufacturer was contacted. He confirmed the suspicion that

pump speed varied with pressure and supplied new curves showing the real relationship. These are replotted in Figure 6. Throughputs of the system were calculated using these graphs to determine S_{40} and S_8 from the measured ion pump currents which are proportional to the pressure at the pump flanges. We designate the pump pressures thus determined as P_{40} and P_8 . Q_{40} and Q_8 in Equations 1, 3 and 4 have been determined in this way rather than by the relations $Q_8 = S_8 P_4$ and $Q_{40} = S_{40} P_6$. P_4 and P_6 do not correspond to the pressures indicated by the ion pump current values because there is a conductance drop between these ion gauges and their respective pumps. The primary procedures for determining the orifice conductances follows.

The test gas, nitrogen in this case, was admitted to the system through the variable leak and allowed to reach equilibrium as indicated by constant ion gauge readings. At this point all gauge readings were recorded along with the pump current. Input (cylinder) pressure was then varied from 10 to 40 psig in 10 steps and the gauge and pump readings again recorded at each equilibrium point. Conductance calculations were made for each orifice; the results are presented in Tables 1, 2, and 3. The ion gauge readings shown in the Tables have been corrected for the sensitivity of the test gas, nitrogen. The average conductance values are:

$$C_{12} = (Q_{40} + Q_8) / (P_1 - P_2) = 0.01682 \text{ liters/second} \text{----Table 1}$$

$$C_{24} = Q_{40} / (P_2 - P_3) = 0.129 \text{ liters/second} \text{-----Table 2}$$

$$C_{23} = Q_8 / (P_2 - P_4) = 0.0057 \text{ liters/second} \text{-----Table 2}$$

$$C_{56} = Q_{40} / (P_5 - P_6) = 0.64 \text{ liters/second} \text{-----Table 3}$$

ION PUMP SPEED VS. PRESSURE (FOR NITROGEN)

8 LITERS PER SECOND PUMP

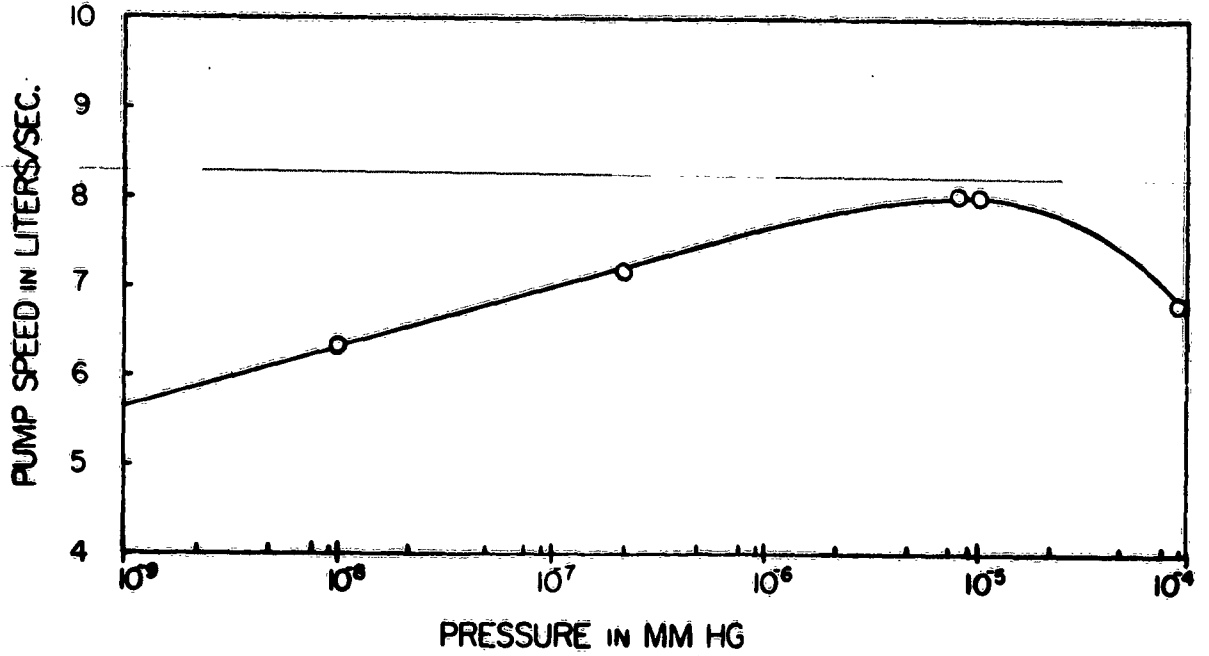

40 LITERS PER SECOND PUMP

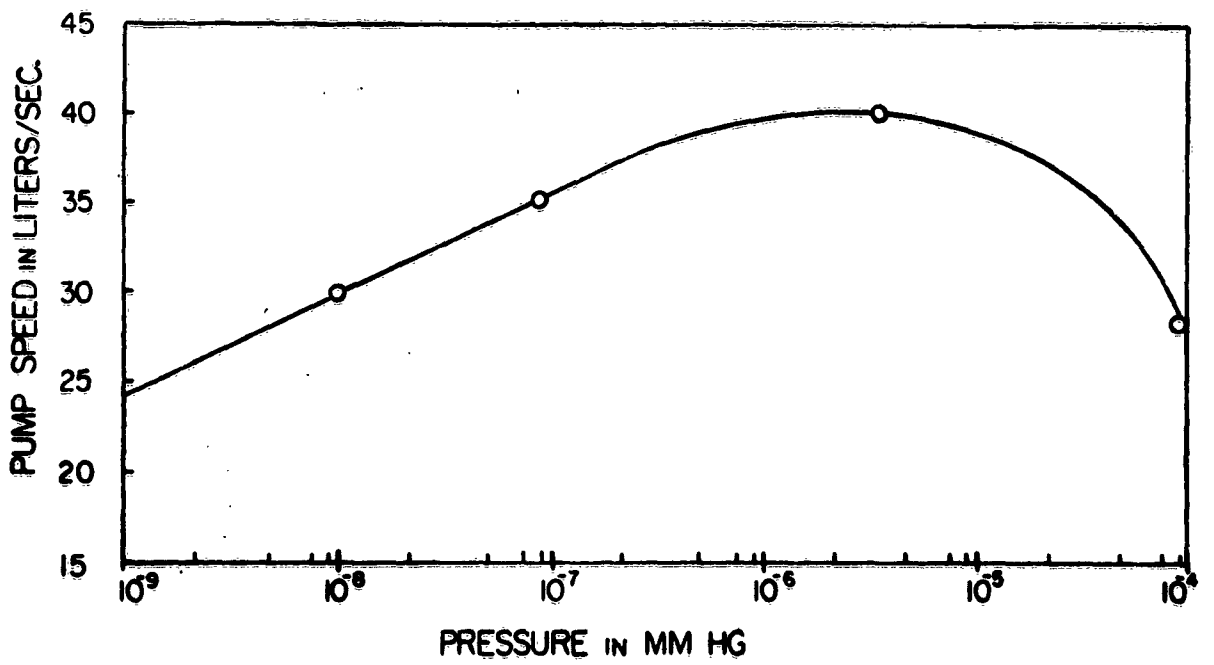

Figure 6

Table 1

P_1	P_2	S_8	P_8	S_{40}	P_{40}	C_{12}
3.0×10^{-4}	4.2×10^{-5}	7.39 1/s	5.8×10^{-7}	29.2 1/s	7.0×10^{-9}	0.0174
4.1	5.4	7.45	7.5	29.6	8.5	0.0164
4.9	6.5	7.49	8.5	29.8	9.2	0.0156
5.9	7.4	7.51	1.0×10^{-6}	30.2	1.1×10^{-8}	0.0152
6.7	8.9	7.60	1.3	30.5	1.3	0.0177
8.1	9.8	7.63	1.5	31.0	1.5	0.0167
2.0	2.9	7.29	4.0×10^{-7}	28.2	5.1×10^{-9}	0.0181
2.1	3.0	7.32	4.3	28.8	5.8	0.0185
3.2	4.6	7.40	6.0	29.4	7.6	0.0168
4.0	5.2	7.44	7.0	29.8	8.5	0.0158

Table 2

	$\frac{P2}{S8}$	$\frac{P3}{S8}$	$\frac{P4}{S8}$	$\frac{P8}{S8}$	$\frac{S40}{S8}$	$\frac{P40}{S8}$	$\frac{C23}{S8}$	$\frac{C24}{S8}$
	2.63×10^{-5}	7.02×10^{-7}	2.94×10^{-6}	3.6×10^{-7}	28.6	5.5×10^{-9}	.0061	.11
3.11	8.62	3.65	7.33	4.7	28.8	5.8	.0055	.13
3.47	1.04×10^{-6}	4.06	7.35	5.0	29.1	6.9	.0060	.12
4.07	1.17	4.67	7.40	6.0	29.3	7.3	.0054	.13
4.55	1.38	5.17	7.44	7.0	29.5	8.0	.0054	.13
5.14	1.49	5.88	7.46	8.0	29.8	8.8	.0053	.13
4.79	1.38	5.48	7.48	7.8	29.7	8.7	.0056	.14
4.19	1.17	4.97	7.42	6.8	29.4	7.8	.0056	.14
3.71	1.07	4.37	7.39	5.9	29.2	7.3	.0059	.13
3.23	8.95×10^{-7}	3.76	7.34	4.9	28.9	6.3	.0058	.13

Table 3

<u>P₄₀</u>	<u>S₄₀</u>	<u>P₃</u>	<u>P₅</u>	<u>P₆</u>	<u>C₅₆</u>
5.5×10^{-9}	28.6	6.60×10^{-7}	2.17×10^{-7}	2.54×10^{-8}	.82
6.2	29.0	8.73	2.71	2.79	.74
7.0	29.2	1.03×10^{-6}	3.44	2.96	.65
7.8	29.4	1.38	3.70	3.22	.68
8.5	29.6	1.60	4.70	3.38	.58
3.3×10^{-8}	32.8	6.82	2.08×10^{-6}	9.32	.55
3.5	33.0	6.20	2.08	8.47	.58
2.8	32.5	4.89	1.63	8.13	.59
1.5×10^{-7}	36.5	2.66×10^{-5}	9.94	2.96×10^{-7}	.57
1.2	36.0	2.02	6.69	2.63	.67

A measure of the uniformity of the conductance values for each orifice is obtained from Table 3A. In the table \bar{C} is the average of 10 conductance values for the orifice; σ is the standard deviation; R is the range.

Table 3A (n=10)

Orifice	\bar{C}	σ	R	Percent of C within		
				$\pm 3\sigma$	$\pm 2\sigma$	$\pm 1\sigma$
O ₁₂	.01682	.001	.0033 (3.3 σ)	100	100	50
O ₂₄	.129	.0088	.03 (3.4 σ)	100	90	70
O ₂₃	.0057	.00015	.0008 (5.3 σ)	100	70	30
O ₅₆	0.64	.086	.27 (3.1 σ)	100	90	70

In designing the gas analysis system, the expected orifice conductance values were calculated from the orifice dimensions in accordance with Dushman's equation as discussed in the First Quarterly Report:

$$C = \frac{3.82D^3}{L+1.33D} \left(\frac{T}{M} \right)^{1/2}$$

where D is the orifice diameter in centimeters

L is the orifice length in centimeters

T is the absolute temperature in $^{\circ}$ Kelvin

M is the molecular weight of the gas in grams per mole.

These calculated values are compared with the experimental values below:

	(1) Calculated	(2) Experimental	% difference from (1)
C ₁₂	.0100	.0168	+68.0
C ₂₃	.0042	.0057	+35.7
C ₂₄	.0830	.1290	+56.6
C ₅₆	.4020	.64	+59.2

At present, we have no verified explanation of the considerable discrepancy between the two sets of values. The most probable explanation of the differences is that the actual pumping speeds of the two ion pumps are lower than the nominal values given by the manufacturer. The conductance values are internally consistent, however. We plan to obtain a suitable standard leak and calibrate the ion pump speeds more accurately if time permits.

DETERMINATION OF QUANTITIES OF GASES EVOLVED

The gas analysis system was designed so that both the types and quantities of gases evolved could be determined. Approximately 5% of the gas from the tube under test or from the test supply passes through the omegatron tube for analysis as determined by the ratio of orifice conductances in the two legs of the system. Knowing the total and partial pressures of the gases, their pumping speeds, and the total degassing time, it is possible to determine from the omegatron reading the total amount of each gas evolved.

The actual ratio of throughput in the omegatron section to total throughput in the system is given by $\frac{Q_{40}}{Q_{40} + Q_8}$. Using data from Tables 1 and 2, the ratio is calculated and presented in Table 4. The average value from 2 sets of ten readings is 0.0444 or 4.44% passing through the omegatron tube. Although this figure is based on the data for nitrogen, it is valid for all the gases encountered because both pumps are of the same type and pump equal fractions of each kind of gas.

It is now necessary to establish the relationship between the partial pressures determined by the omegatron and the total evolved. Data from Figure 6 was used to plot throughput as a function of pressure for the 40 l/sec. pump and is shown in Figure 7 for the range 10^{-4} to 10^{-9} Torr. If we determine the conductance between the omegatron and the 40 l/s ion pump it is then possible to calculate the pressure in the omegatron, P_0 , against which the throughput, Q_{40} , can be plotted.

$$P_0 = Q_{40}/C_{0-40} + P_{40}$$

where C_{0-40} is the conductance between the omegatron and the 40 l/s pump.

Table 4

	<u>Q₄₀</u>	<u>Q₈</u>	<u>Q₄₀ / (Q₈ + Q₄₀)</u>
1.	2.04x10 ⁻⁷	4.44x10 ⁻⁶	.0438
2.	1.76x10 ⁻⁷	4.13x10 ⁻⁶	.0409
3.	1.57x10 ⁻⁷	3.51x10 ⁻⁶	.0427
4.	1.42x10 ⁻⁷	2.80x10 ⁻⁶	.0481
5.	2.04x10 ⁻⁷	4.29x10 ⁻⁶	.0455
6.	2.52x10 ⁻⁷	5.59x10 ⁻⁶	.0431
7.	2.66x10 ⁻⁷	6.38x10 ⁻⁶	.0400
8.	3.32x10 ⁻⁷	7.51x10 ⁻⁶	.0423
9.	3.97x10 ⁻⁷	9.88x10 ⁻⁶	.0386
10.	4.65x10 ⁻⁷	11.45x10 ⁻⁶	.0391
11.	1.57x10 ⁻⁷	2.62x10 ⁻⁶	.0567
12.	1.67x10 ⁻⁷	3.45x10 ⁻⁶	.0463
13.	2.01	3.68	.0518
14.	2.14	4.44	.0459
15.	2.36	5.21	.0433
16.	2.62	5.97	.0421
17.	2.58	5.83	.0424
18.	2.29	5.05	.0434
19.	2.13	4.36	.0437
20.	1.82	3.60	.0482

THROUGHPUT VS. PRESSURE (FOR 40 L/SEC. ION PUMP)

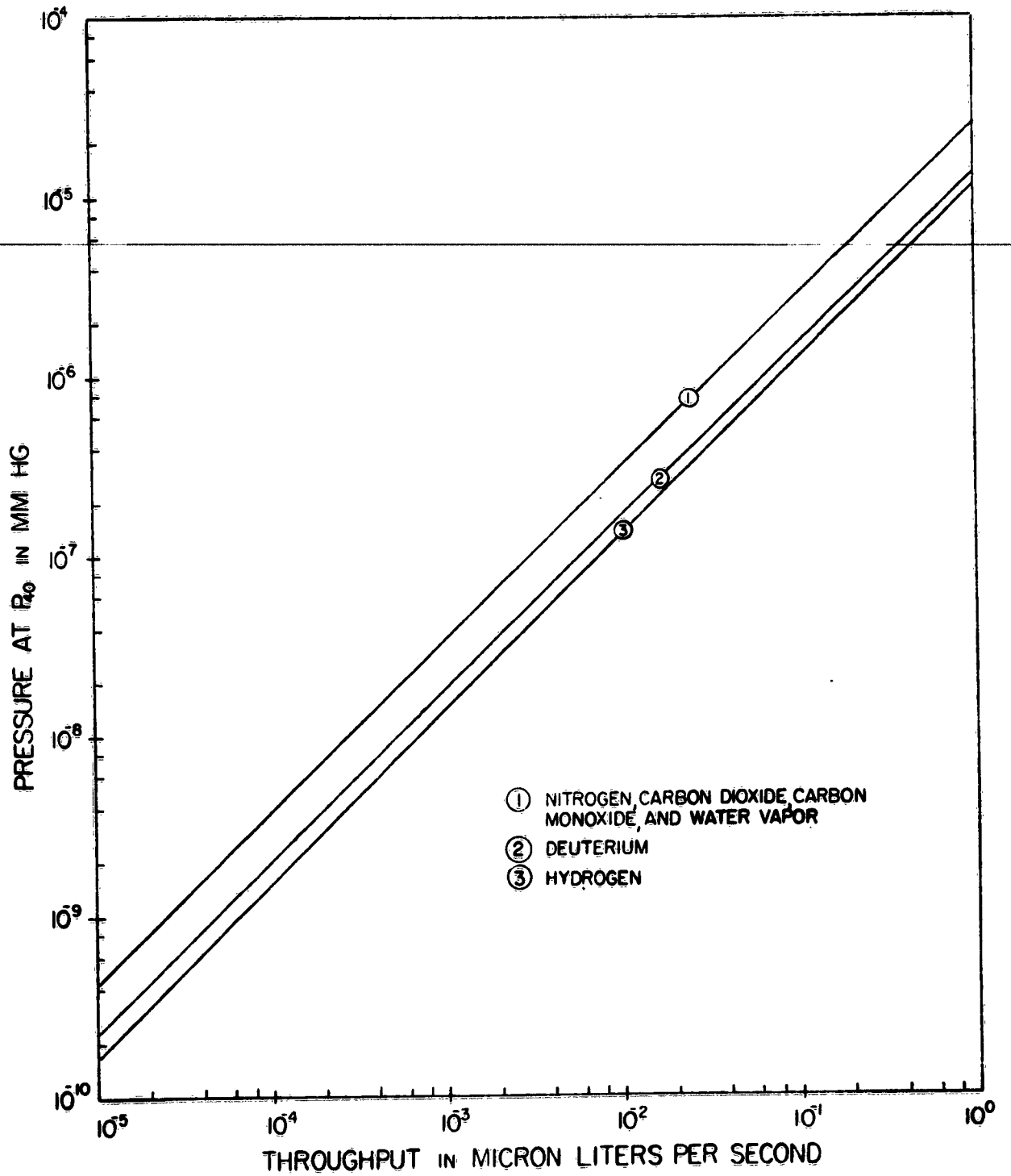

Fig. 7

First, the conductance between P_3 and P_5 was calculated from data in Table 3 from the formula:

$$C_{3-5} = \frac{Q_{40}}{P_3 - P_5} \cdot \text{where } C_{3-5} \text{ is the conductance between ion gauges } P_3 \text{ and } P_5.$$

The average of 10 values was 0.272 liters/second with a range of 0.355-0.214=0.141.

The omegatron tube is located between the ion gauges designated P_3 and P_5 . To determine the pressure (P_0) at the omegatron, the conductance between it and P_5 must be known. This is calculated from the length and diameter of the glass tubing between them, the temperature, and the molecular weight of the gas. The total conductance between the omegatron and the 40 l/s ion pump is then obtained from the relation:

$$\frac{1}{C_T} = \frac{1}{C_1} + \frac{1}{C_2} + \dots + \frac{1}{C_n}$$

which applies for conductances in series. It was not possible to determine the conductance between P_0 and P_5 experimentally because the presence of the magnet in position at the omegatron caused erroneous readings at the ion gauges P_3 and P_5 . The value computed was $C_{0-5} = 0.382$ liters/second for nitrogen.

Calculation of the conductance between P_5 and the P_{40} (the 40 l/sec. ion pump) was based on data from Table 3 and shown in Table 5 using the relation:

$$C_{5-40} = \frac{Q_{40}}{P_5 - P_{40}} \cdot$$

Table 5

P_5	P_{40}	Q_{40}	$C_{P_5 - P_{40}}$
2.17×10^{-7}	5.5×10^{-9}	1.58×10^{-7}	0.75
2.71	6.2	1.73	0.65
3.44	7.0	2.05	0.62
3.70	7.8	2.29	0.63
4.70	8.5	2.52	0.55
1.08×10^{-6}	3.3×10^{-8}	1.08×10^{-6}	0.53
2.08	3.5	1.16	0.57
1.63	2.8	9.10×10^{-7}	0.57
9.94	1.5×10^{-7}	5.48×10^{-6}	0.55
6.69	1.2	4.32	0.66

The average of ten values gives $C_{5-40} = 0.61$ liters/second. Using the foregoing values, the conductance between the omegatron and the 40 liter/sec. pump is obtained from:

$$\begin{aligned} C_{0-40} &= \frac{C_{0-5} \times C_{5-40}}{C_{0-5} + C_{5-40}} \\ &= \frac{0.382 \times 0.61}{0.382 + 0.61} \\ &= 0.235 \text{ liters/sec.} \end{aligned}$$

Substituting this value in the equation for P_o ,

$$P_o = \frac{Q_{40}}{C_{0-40}} + P_{40} .$$

We obtained values of P_o which were then plotted against Q_{40} , the throughput. The graph is shown in Figure 8 and permits us to determine the quantity of nitrogen passing through the omegatron per second. Dividing the quantity so obtained by 0.0444 (the ratio of Q_{40} throughput to total throughput of the system) gives us the total degassing rate of the tube under test. This is plotted in Figure 9 as a function of the omegatron pressure for nitrogen.

Similar calculations and plots have been made for other gases expected in operation. Since the pump speed for the gases CO_2 , CO , and H_2O is the same as that for nitrogen, we need only change the conductance values used in the previous equation to determine the omegatron pressure for these gases. The conductance values for different gases are in the ratio of the square root of their molecular weights. The molecular weight of CO is the same as that for nitrogen and the curve in Figure 9 has therefore been marked Nitrogen-Carbon Monoxide. Conductance factors for the remaining gases are as follows:

THROUGHPUT VS. OMEGATRON PRESSURE

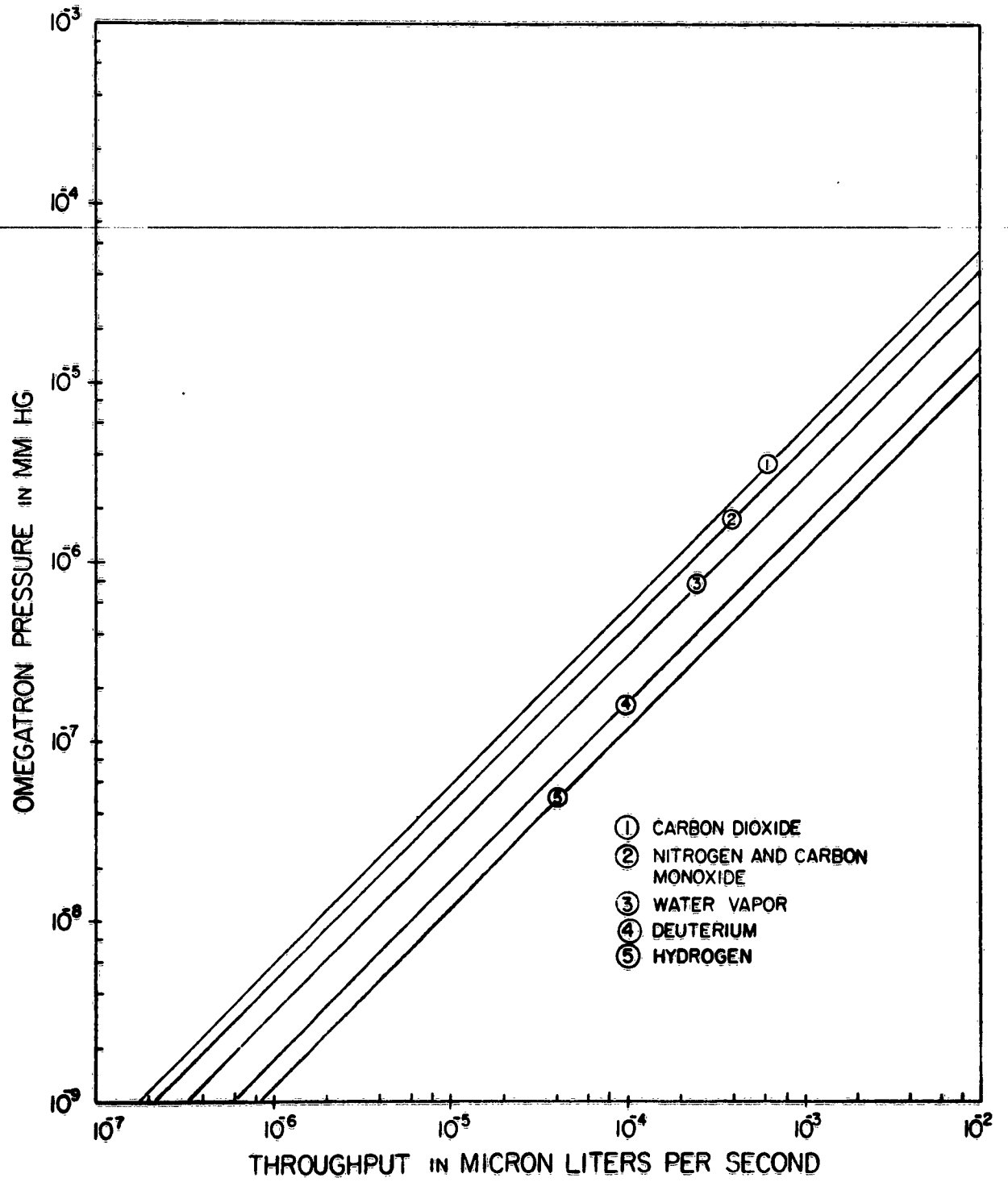

Figure 8

TOTAL GAS RATE VS. OMEGATRON PRESSURE

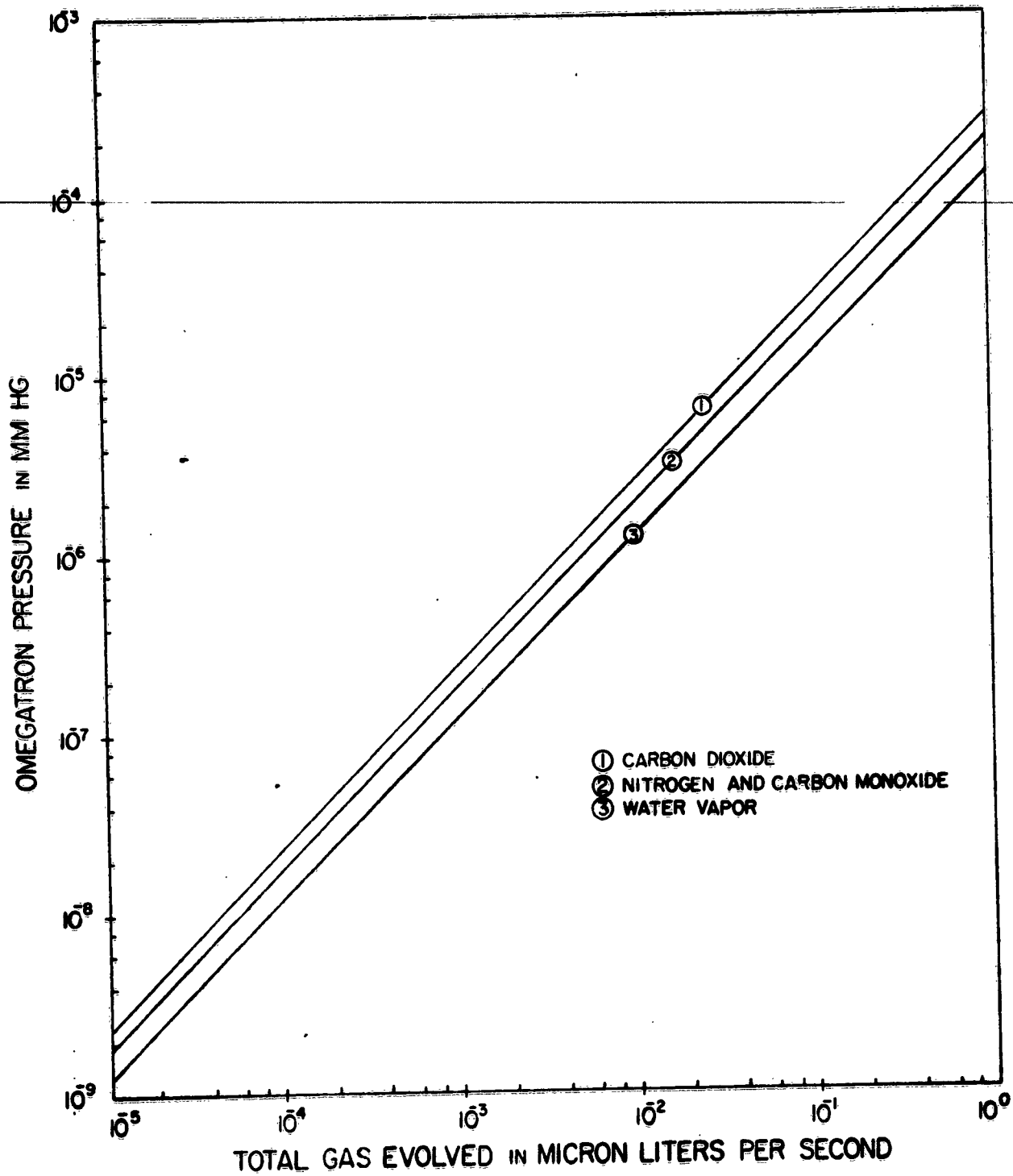

Figure 9

CO₂-----0.797

D₂-----2.65

H₂-----3.75

H₂O-----1.25

CH₄-----1.33

Substituting the correct conductance values in the equation, the omegatron pressure as a function of throughput is calculated for each gas and plotted in Figure 8. For water vapor and carbon dioxide whose pumping speeds are the same as for nitrogen, the same throughputs were used in the calculations. For deuterium, however, the pumping speed is 190 times that for nitrogen while for hydrogen the pumping speed is 270 times that for nitrogen. Throughputs calculated for these speed ratios were substituted in the equation along with the proper conductance values to obtain the data used in plotting the various curves in Figures 7, 8, and 9. The pumping speed used for methane is not known. It will be determined during the next quarter. Indications are that it is fairly close to that for nitrogen.

PRELIMINARY DEGASSING OF AMPEREX TUBE

Although the calibration of the throughput of methane was still to be performed, a decision was made to test the system by a preliminary degassing of the Amperex tube. An RF coil of copper tubing was wound around and adjusted to fit around the tube under test. As an independent check on the omegatron throughput, deuterium gas was introduced to the system at a slow rate. See the First Quarterly Report, page 14, for further details.

An omegatron scan taken immediately after turning on the RF unit revealed a large mass peak at a charge-to-mass ratio of 20. Since no peak was detected at 40, the peak at 20 could not be doubly ionized argon. It was judged, therefore, to be D_2O formed by the reaction of deuterium with oxygen liberated by the degassing operation (no free oxygen was detected). The other gases detected were CO_2 , H_2O , N_2 , and CO . As the RF current was increased the peak height of D_2O increased, then decreased as the quantity of gas driven off the tube elements decreased. However, the height of the deuterium peak needs to be examined more closely to determine the exact correlation that must exist.

The general procedure for determining the quantity of gases evolved in the Amperex tube is as follows:

1. Set the RF current at a value such that the degassing rate remains fairly constant.
2. Scan from mass 44 to mass 2 every five minutes.
3. Record the height of the peaks for each five minute period.
4. Calculate the partial pressure of each gas for the period.
5. Determine the total degassing rate of each gas evolved using Fig.9
6. Compute total gas evolved by multiplying the value for each gas from (5) above by a factor of 300 (throughput in micron-liters/sec. x 60 sec./min. x 5 min.).

In holding the total degassing rate at a low value and as nearly constant as possible, we are, of course, assuming that the degassing rate of the various individual gases remains constant over the five minute period required for the scan. It may be possible to infer the accuracy of this assumption by varying the start of the scanning with respect to the start of the RF heating. We plan to attempt tests of this nature, among others, during the next period.

APPENDIX I

IONIZATION GAUGE CALIBRATION DATA FOR HYDROGEN

Gauge No.	1	2	3	4	5	6
Pressure Rise (10 ⁻⁵ Torr/min)	3.32	3.96	4.12	4.28	3.36	5.16
	3.36	4.48	4.44	4.40	3.52	5.32
	2.88	4.36	4.48	3.92	3.08	5.12
	3.44	4.48	4.76	4.20	3.24	5.36
	3.68	4.36	4.40	--	3.56	--
ΣX	16.68	21.64	22.20	16.80	16.76	20.96
\bar{X}	3.34	4.33	4.44	4.20	3.35	5.24

SENSITIVITIES OF THE GAUGES FOR HYDROGEN

S ₁	S ₂	S ₃	S ₄	S ₅	S ₆
4.07	5.28	5.12	5.42	4.09	6.39

PERSONNEL

Contributing to this phase of the contract were the following engineering and scientific personnel:

Mr. W. J. Grubbs
Mr. G. H. Snider
Mr. F. I. Scott
Dr. E. I. Doucette
Mr. W. A. Taylor
Mr. D. S. Porter
Mr. J. D. Muriano

APPENDIX II

IONIZATION GAUGE CALIBRATION FOR DEUTERIUM

Gauge No.	1	2	3	4	5	6
Pressure Rise (10^{-5} Torr/min)	1.89	1.86	2.22	1.26	1.20	2.16
	2.13	2.01	2.40	1.35	1.35	2.22
	2.10	1.89	2.52	1.38	1.32	2.25
	2.25	1.95	2.58	1.44	1.50	2.52
	2.16	1.92	2.43	1.32	1.26	2.25
ΣX	10.52	9.63	12.15	6.75	6.63	11.40
\bar{X}	2.11	1.93	2.43	1.35	1.33	2.28

SENSITIVITIES OF THE GAUGES FOR DEUTERIUM

S_1	S_2	S_3	S_4	S_5	S_6
3.63	3.32	2.32	4.18	2.29	3.92

LIST A

<u>Code</u>	<u>Organization</u>	<u>No. of Copies</u>
AF 5	AFMTC (AFMTC Tech Library - MU-135) Patrick AFB, Fla.	1
AF 18	AUL Maxwell AFB, Ala.	1
AF 43	ASD (ASAPRD - Dist) Wright-Patterson AFB, Ohio	1
AF 124	RADC (RAYLD) Griffiss AFB, New York Attn: Documents Library	1
AF 139	AF Missile Development Center (MDGRT) Holloman AFB, New Mexico	1
AF 314	Hq. OAR (RR0SE) Washington 25, D. C.	1
AF 318	ARL (ARA=2) Library AFL 2292, Building 450 Wright-Patterson AFB, Ohio	1
Ar 5	Commanding General USASRD Ft. Monmouth, N.J. Attn: Tech. Doc. Ctr. SIGRA/SL-ADT	1
Ar 9	Department of the Army Office of the Chief Signal Officer Washington 25, D. C. Attn: SIGRD-4a-2	1
Ar 50	Commanding Officer Attn: ORDTL-012 Diamond Ordnance Fuze Laboratories Washington 25, D. C.	1
Ar 67	Redstone Scientific Information Center U.S. Army Missile Command Redstone Arsenal, Alabama	1
G 31	Office of Scientific Intelligence Central Intelligence Agency 2430 E. Street, N.W. Washington 25, D. C.	1
G 2	ASTIA (TIPAA) Arlington Hall Station Arlington 12, Virginia	10

List A - Page 2

<u>Code</u>	<u>Organization</u>	<u>No. of Copies</u>
G 68	National Aeronautics and Space Agency 1520 H Street, N.W. Washington 25, D. C. Attn: Library	1
G 109	Director Langley Research Center National Aeronautics and Space Administration Langley Field, Virginia	1
N 9	Chief, Bureau of Naval Weapons Department of the Navy Washington 25, D. C. Attn: DLI-31	2
N 29	Director (Code 2027) U.S. Naval Research Laboratory Washington 25, D. C.	2
I 292	Director, USAF Project RAND The Rand Corporation 1700 Main Street, Santa Monica, California THRU: AF Liaison Office	1
M 6	AFCRL, OAR (CRXRA - Stop 39) L. G. Hanscom Field Bedford, Mass. (Please mail separately from any other reports going to this Headquarters as these must be sent to our Documents Sec- tion)	10
AF 253	Technical Information Office European Office, Aerospace Research Shell Building, 47 Cantersteen Brussels, Belgium	1
Ar 107	U.S. Army Aviation Human Research Unit U.S. Continental Army Command P. O. Box 428, Fort Rucker, Alabama Attn: Maj. Arne H. Eliasson	1
G 8	Library Boulder Laboratories National Bureau of Standards Boulder, Colorado	2
M 63	Institute of the Aerospace Sciences, Inc. 2 East 64th Street New York 21, New York Attn: Librarian	1

List A - Page 3

<u>Code</u>	<u>Organization</u>	<u>No. of Copies</u>
M 84	AFCRL, OAR (CRXR, J.R. Marple) L. G. Hanscom Field Bedford, Mass.	1
N 73	Office of Naval Research Branch Office, London Navy 100, Box 39 F.P.O., New York, New York	6
U 32	Massachusetts Institute of Technology Research Laboratory Building 26, Room 327 Cambridge 39, Massachusetts Attn: John H. Hewitt	1
U 431	Alderman Library University of Virginia Charlottesville, Virginia	1
G 9	Defence Research Member Canadian Joint Staff 2450 Massachusetts Avenue, N.W. Washington 8, D. C.	1
AF 329	Hq. ARDC (RDR-62) Reference 4619 - Ca Andrews AFB, Washington 25, D.C.	2
G 65	National Aeronautics and Space Administration 1520 H Street, N.W. Washington 25, D.C. Attn: C7-446	2
I 234	Ronson Metals Corporation 45-65 Manufacturers Place Newark 5, New Jersey Attn: Mr. Bernard M. Berzon	2
I 367	Stanford Research Institute Documents Center Menlo Park, California Attn: Acquisitions	1
I 370	General Telephone and Electronics Lab., Inc. Bayside, New York Attn: Dr. T. G. Polanyi, Head Thermionics Branch	1

List A - Page 4

<u>Code</u>	<u>Organization</u>	<u>No. of Copies</u>
I 371	Battelle Memorial Institutue 505 King Avenue Columbus, Ohio Attn: Report Library	1
I 475	Briggs Associates 10 Dekalb Street Norristown, Pennsylvania Attn: Mr. T. H. Briggs	1
I 816	General Electric Company Electronic Components Division One River Road Schenectady, New York Attn: Dr. N. J. Hawkins Room 201, Building 269 Tube Technology Engineering	1
	Mrs. Mary Helen Faust RCA Library Electron Tube Division 3301 South Adams Street Marion, Indiana	1
	Remaining copies to: Hq. AFCRL, OAR (CRRCP, J. Bloom) L.G. Hanscom Field, Bedford, Mass.	10