

UNCLASSIFIED

AD 297 107

*Reproduced
by the*

**ARMED SERVICES TECHNICAL INFORMATION AGENCY
ARLINGTON HALL STATION
ARLINGTON 12, VIRGINIA**



UNCLASSIFIED

NOTICE: When government or other drawings, specifications or other data are used for any purpose other than in connection with a definitely related government procurement operation, the U. S. Government thereby incurs no responsibility, nor any obligation whatsoever; and the fact that the Government may have formulated, furnished, or in any way supplied the said drawings, specifications, or other data is not to be regarded by implication or otherwise as in any manner licensing the holder or any other person or corporation, or conveying any rights or permission to manufacture, use or sell any patented invention that may in any way be related thereto.

0-25
9106

FORWARDED BY THE CHIEF, BUREAU OF...

AS AD No. 2971 Q 7



AMERICAN MACHINE & FOUNDRY COMPANY • 1025 NORTH ROYAL STREET, ALEXANDRIA, VIRGINIA

THIS DOCUMENT IS RELEASED WITH NO RESTRICTIONS ON DISSEMINATION

ALEXANDRIA DIVISION

FINAL DEVELOPMENT REPORT
FOR
IMPROVEMENTS OF
RADIAC SET
AN/PDR-58(XN-1)

This final report covers the period from May 1962 through January 1963

AMERICAN MACHINE & FOUNDRY COMPANY
ALEXANDRIA DIVISION
1025 NORTH ROYAL STREET
ALEXANDRIA, VIRGINIA

NAVY DEPARTMENT BUREAU OF SHIPS
ELECTRONICS DIVISION

NObsr 87484

SF011-05-04, Task 6007

January 1963

ABSTRACT

An experimental program was conducted to improve the neutron energy response of the neutron scintillation detector of the U. S. Navy AN/PDR-58 (XN-1) Neutron Survey Meter.

The final neutron detector developed very closely approximates the ~~mean~~^{*} ~~rate~~⁼¹ per unit neutron flux for neutron energies from .025 ev to 15 Mev as specified in NBS Handbook 63. In addition, the final detector has a much higher overall sensitivity.

ACKNOWLEDGMENTS

The Alexandria Division of AMF wishes to express its gratitude to Mr. C. S. Hollander, Project Engineer, and Mr. G. N. Mahaffey, Head of the Equipment Design Section of the Electronics Division, Code 685C of the Navy Bureau of Ships, for their guidance during the course of this contract. Thanks is also extended to Mr. George Hitchcock of the U. S. Naval Radiological Defense Laboratory for his invaluable assistance in tests conducted with the Van de Graff at that installation.

AMF personnel who contributed to the program are W. P. Saylor, D. R. Dellinger, A. W. Carriker, A. A. Sterk, R. L. Simms, A. Powers, R. N. Stock, G. L. Gordon, H. C. Price, S. T. Lonberger, and C. L. Morrison. The detector development effort and experimental measurements are to the credit, principally, of W. P. Saylor. Electronic modifications were the responsibility of D. R. Dellinger and R. N. Stock. Program supervision was provided by A. W. Carriker and A. A. Sterk.

CONTENTS

	<u>Page No.</u>
PART I -----	1
A. PURPOSE -----	1
B. GENERAL FACTUAL DATA -----	1
1. Definitions of Problem -----	1
2. Approach to Problem Solution -----	6
C. DETAILED FACTUAL DATA -----	8
1. Preliminary One Mev Neutron Energy Measurements -----	8
2. Thermal Neutron Energy Measurements -----	9
3. Fast Neutron Energy Measurements -----	12
4. Neutron Survey Meter Circuit Modification -----	20
D. CONCLUSION -----	26
PART II - RECOMMENDATIONS -----	28

LIST OF ILLUSTRATIONS

		<u>Page No.</u>
Figure 1.	Neutron Detector Diagram -----	4
Figure 2.	Measured Detector Responses As a Function of Neutron Energy for the Class I and Class II Type Detectors -----	7
Figure 3.	Neutron Detector Response at 1.24 Mev as a Function of Li^6F Loading Per Interface on 6 Interfaces -----	10
Figure 4.	Neutron Detector Response as a Function of $\text{ZnS}(\text{Ag})$ Interfaces Removed for Various Neutron Energies -----	13
Figure 5.	Neutron Detector Response at 1.24 Mev as a Function of 60 mg Li^6F Loaded on Various Interfaces -----	15
Figure 6.	Dose Rate Response as a Function of Neutron Energy for Various Neutron Detectors -----	16
Figure 7.	Final Detector Dose Rate Response As a Function of Neutron Energy -----	17
Figure 8.	Neutron Survey Meter Detector Response vs Neutron Energy Compared to the Ideal Neutron Detector Response and a 10" Polyethylene Sphere Response -----	18
Figure 9.	Neutron Survey Meter Probe Schematic -----	22
Figure 10.	Neutron Survey Meter Main Amplifier Schematic -----	24
Figure 11.	Circuit Modification of One Shot Multivibrator -----	25

LIST OF TABLES

	<u>Page No.</u>
Table 1. Elements of Neutron Detector and Shield	3
Table 2. Results of Equation 5	5
Table 3. Thermal Neutron Measurements	11
Table 4. Response of Detectors in cpm/mrem hr ⁻¹ For PuBe and PuF ₄ Neutrons	19
Table 5. Comparison of Various Neutron Monitoring Instruments	20

PART I

A. PURPOSE

The research and development effort of this program was directed toward improving (1) the neutron energy response of the scintillation detector, and (2) the meter circuitry, associated with the AN/PDR-58 (XN-1) Neutron Survey Meter developed for the United States Navy under Contract NObsr 77552. These improvements will ultimately aid the instruments in their biological measurements of neutron radiation fields.

B. GENERAL FACTUAL DATA

1. Definition of Problem

The final neutron detectors constructed for the AN/PDR-58 (XN-1) instruments that were delivered under Contract NObsr 77552 were designed on the basis of data obtained from a series of experiments with monoenergetic neutrons. Unfortunately, because of Contract time and Funding restraints no neutron energy response data was taken for the final detectors when surrounded by the B^{10} -Mn-Ti shields. (The purpose of the shields was to modify the neutron response of the detectors from thermal energy to about 50 kev).

The Navy's evaluation of the neutron energy response of the detectors indicated that the response was not as desired. The neutron energy response at one Mev was too low, and the slope of the response curve to higher neutron energies was too steep. It was postulated that the undesirable excess sensitivity with

increasing neutron energy resulted from the additional moderation provided by the shield materials and excess phosphor in the detector. The unexpected lower sensitivity for one Mev neutrons can be theoretically explained as follows:

The average number of collisions, N , required to bring the initial energy, E_i , of an impinging neutron on a material to some final energy, E_f , in a material, is given by:

$$N = \ln (E_i/E_f) // \bar{\xi} \quad *$$
(1)

Where, $\bar{\xi}$, is the average logarithmic decrement of neutron energy per collision.

For a composite moderator,

$$\bar{\xi} = \frac{\sum_{i=1}^n \xi_i \Sigma_{si}}{\sum_{i=1}^n \Sigma_{si}} \quad *$$
(2)

Where Σ_{si} is the macroscopic scattering cross section of the i th element comprising the moderator.

With a few limiting assumptions, the average neutron scattering reaction rate, R , for a given neutron energy, E , and thickness of moderating medium, T , into an average spherical scattering angle, θ , is given by:

$$R = \Sigma_s \phi T // \theta \quad (3)$$

Where, ϕ , is the number of neutrons per second of energy, E , in the medium.

For low atomic number elements one can assume that $\theta \cong 2/3$.*

Therefore, the number of collisions per neutron, N , is given by

$$N = \Sigma_s T // \theta = N_t \sigma_s T // \theta \quad (4)$$

* Experimental Nuclear Physics, Vol. II, E. Segre, John Wiley & Sons, Inc., N. Y., 1953, 479f.

Now by combining equations (1) and (4) one can determine the average final energy, \bar{E}_f , of a neutron of initial energy, \bar{E}_i , in passing through a moderator of source given thickness, T , or

$$\bar{E}_f = \bar{E}_i \exp(-N_t \sigma_s T \bar{\xi} // \theta) . \quad (5)$$

Where N_t = total number of scattering nuclei involved.

Table 1 lists the most important elements of the neutron detector and the shield, along with their physical characteristics.

TABLE 1

Elements Of Neutron Detector And Shield

<u>Element</u>	<u>A(at. wt.)</u>	<u>$\bar{\xi}$</u>	<u>σ_s</u>	<u>$N(10^{24}/cc)$</u>
Hydrogen	1	1	7.6	.0571
Boron - 10	10	.171	4.0	.148
Aluminum	27	.0723	4.0	.0603
Manganese	55	.0359	4.0	.0814
Titanium	48	.0411	4.0	.0566

The neutron detector delivered on contract NObsr 77552, Class I Figure 1, had approximately 1.8 cm of lucite thickness to the Li^6F loaded interfaces, 1.3 cm B^{10} -Mn-Ti shield and .56 cm of aluminum housing. The final neutron detector, Class II Figure 1, had approximately .9 cm of lucite thickness to the Li^6F interface, 1.3 cm B^{10} -Mn-Ti shield and .56 cm of aluminum housing.

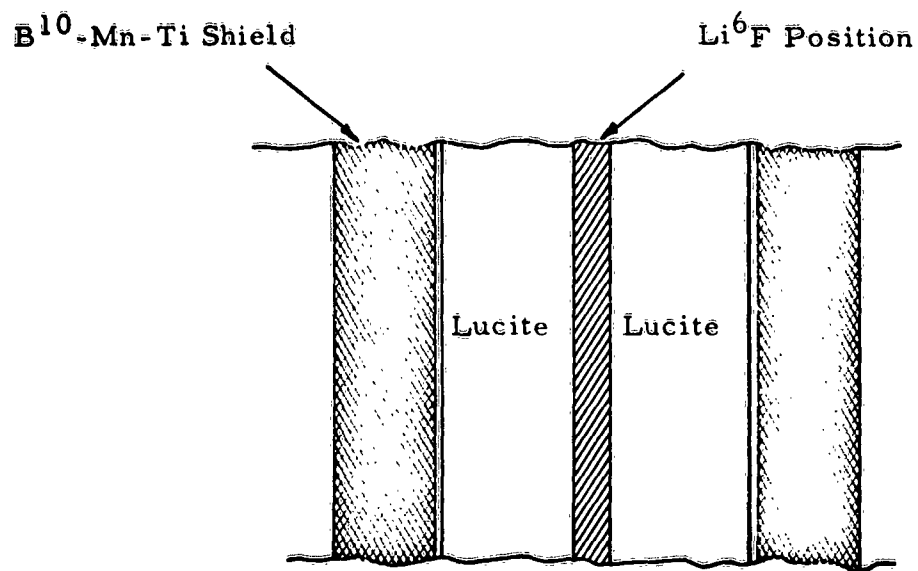

CLASS I

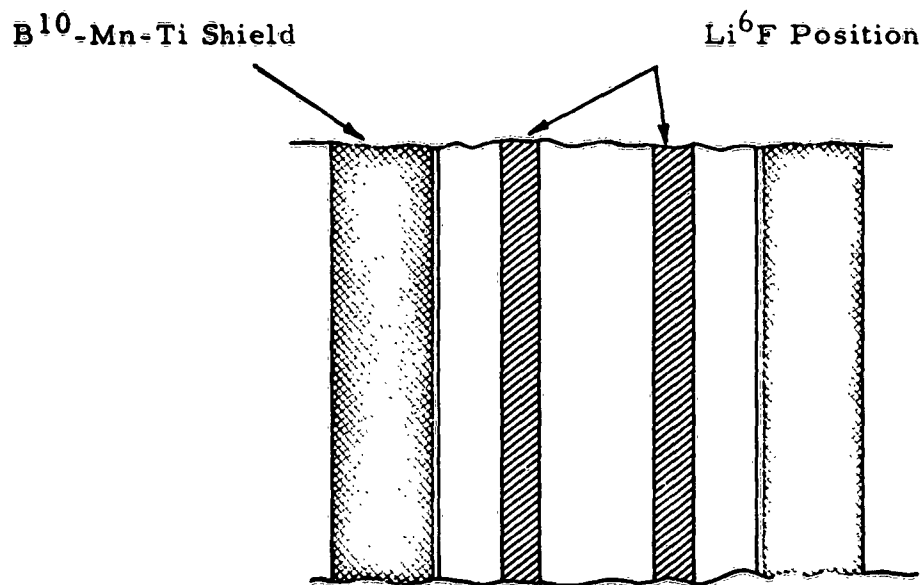

CLASS II

Figure 1. Neutron Detector Diagram (Class I Old Model, Class II New Model).

In relation to detector response to one Mev neutrons, there are three cases that one would like to investigate: (1) the unshielded detector where there is approximately 2 cm of lucite between the incident neutron energy E_i and the Li^6F reactant material (Class I of Figure 1), (2) the shielded detector (Class I of Figure 1), and (3) the shielded detector with only 1 cm of lucite between incident neutrons and Li^6F reactant (Class II of Figure 1). Table 2 shows the results of equation (5).

TABLE 2

Results of Equation 5

<u>Case No.</u>	<u>Class No.</u>	<u>E_i</u>	<u>\bar{E}</u>	<u>N_T</u>	<u>σ_s</u>	<u>T</u>	<u>E_f</u>
(1)	I (unshielded)	1 Mev	1	.0571	7.6	2 cm	.270 Mev
(2)	I (shielded)	1 Mev	.45	.262	4	3.1 cm	.108 Mev
(3)	II (shielded)	1 Mev	.45	.262	4	2.1 cm	.230 Mev

Ideally, it is desirable that the position of the Li^6F interfaces in the detector be such that incident one Mev neutrons would be moderated to an average energy of 0.25 Mev upon reaching the Li^6F loaded interfaces. The reason for this is to take advantage of the $\text{Li}^6(n, \alpha)$ resonance at 0.25 Mev which will build up the detector response at one Mev. *

Table 2 shows that the unshielded Class I detector does in fact give this one Mev

* Neutron Cross Sections, BNL-325.

neutron energy moderations. However, the shielded Class I detector gives too much moderation causing the moderated one Mev neutrons to fall below the 0.25 Mev level or effectively shifts the $\text{Li}^6(n, \alpha)$, resonance to a level higher than one Mev. The Class II shielded detector will cause one Mev neutrons to be moderated to an average value of 0.25 Mev.

Figure 2 confirms the fact that the neutron detector response does change with Li^6F position in the shielded detectors. Figure 2b shows the unshielded Class I detector response, and Figure 2c shows how the response curve is modified when the $\text{B}^{10}\text{-Mn-Ti}$ shield is introduced. Figure 2d shows the shielded Class II detector response curve, indicating that the desired response curve, Figure 2a, can best be approached by changing the position of the Li^6F loaded interfaces in the detector.

The three measured curves of the Class I and II detector of Figure 2 are in fact the sum of the proton recoil (σR)* response plus the $\text{Li}^6(n, \alpha)$ response as shown. And, as the figure depicts, if a neutron detector is to be built that will approximate the desired response dictated by NBS Handbook 63 Figure 2d, the shielded Class II type must be used.

2. Approach to Problem Solution

The necessary changes needed to adjust the neutron energy response of the detectors to the desired values and at the same time maintain high overall

* The proton recoil response is proportional to the hydrogen scattering cross section σ and the proton range in the material. See Final Development Report For Neutron Survey Meter Radiac Set AN/PDR-58 (XN-1) April, 1961, pages 22 and A-21.

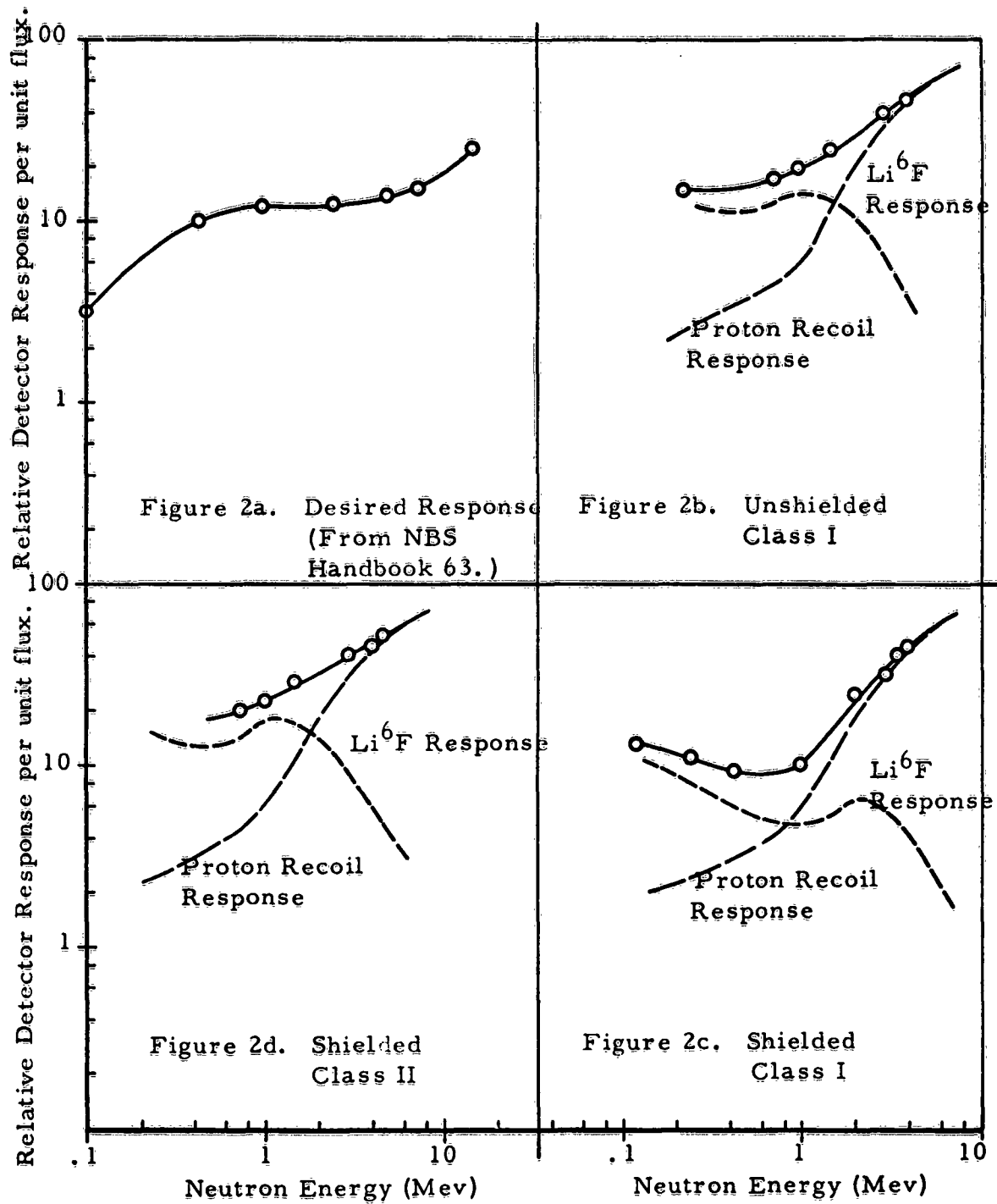

Figure 2. Measured Detector Response As a Function of Neutron Energy for the Class I and Class II Type Detectors.

sensitivity, will require a detector configuration change from Class I to Class II. In addition, more Li^6F will be included in the detectors to boost the response at one Mev. This increase in Li^6F will alter the response at thermal neutron energies requiring a shield configuration change to compensate for this Li^6F loading increase. Therefore, by the proper adjustment of the amount and position of the Li^6F loading and the shield configuration, the proper response at one Mev and thermals can be reached.

The response at 15 Mev is due solely to the neutron elastic scattering proton recoil response which is detected by the $\text{ZnS}(\text{Ag})$ interfaces. Therefore, by adjusting the number of $\text{ZnS}(\text{Ag})$ interfaces included in the detectors, one can adjust the response at 15 Mev to the desired value without affecting the response at one Mev or thermal energies. Thus, adjusting the number of $\text{Zns}(\text{Ag})$ interfaces, Li^6F loading and position, and shield configuration, the response of the neutron detector can be made to match the desired response curve for all neutron energies from thermal to 15 Mev.

C. DETAIL FACTUAL DATA

1. Preliminary One Mev Neutron Energy Measurement

Preliminary one Mev neutron measurements were made with the High Voltage Engineering Corporation's Van de Graaff at Burlington, Massachusetts. The

purpose of these measurements was to establish the optimum Li^6F detector loading needed to boost the response at one Mev. Five detectors were built for these measurements with Li^6F loadings per interface ranging from 33.5 mg to 150 mg loaded on 6 separate interfaces. The results of these measurements are depicted by Figure 3. As shown by Figure 3, the optimum Li^6F loading per interface is 60 mgs. Therefore, in order to increase the detector response it would be necessary to extend the number of interfaces loaded with 60 mgs Li^6F to values higher than 6.

2. Thermal Neutron Energy Measurement

Thermal neutron measurements were conducted in the Termal Column of the IRL reactor Plainsboro, New Jersey. The five detectors constructed for the one Mev neutron measurements were also used for this test. The results of the thermal neutron measurements are given in Table 3.

Thermal neutron detector response measurements taken without cadmium surrounding the PM tube and base gave detector responses of approximately a factor of 100 higher than when the PM tube and base were covered with cadmium. This indicates that quite a number of thermal neutrons were being scattered up through the PM tube into the detector.

Theoretical calculations indicate that the intermediate neutron energy

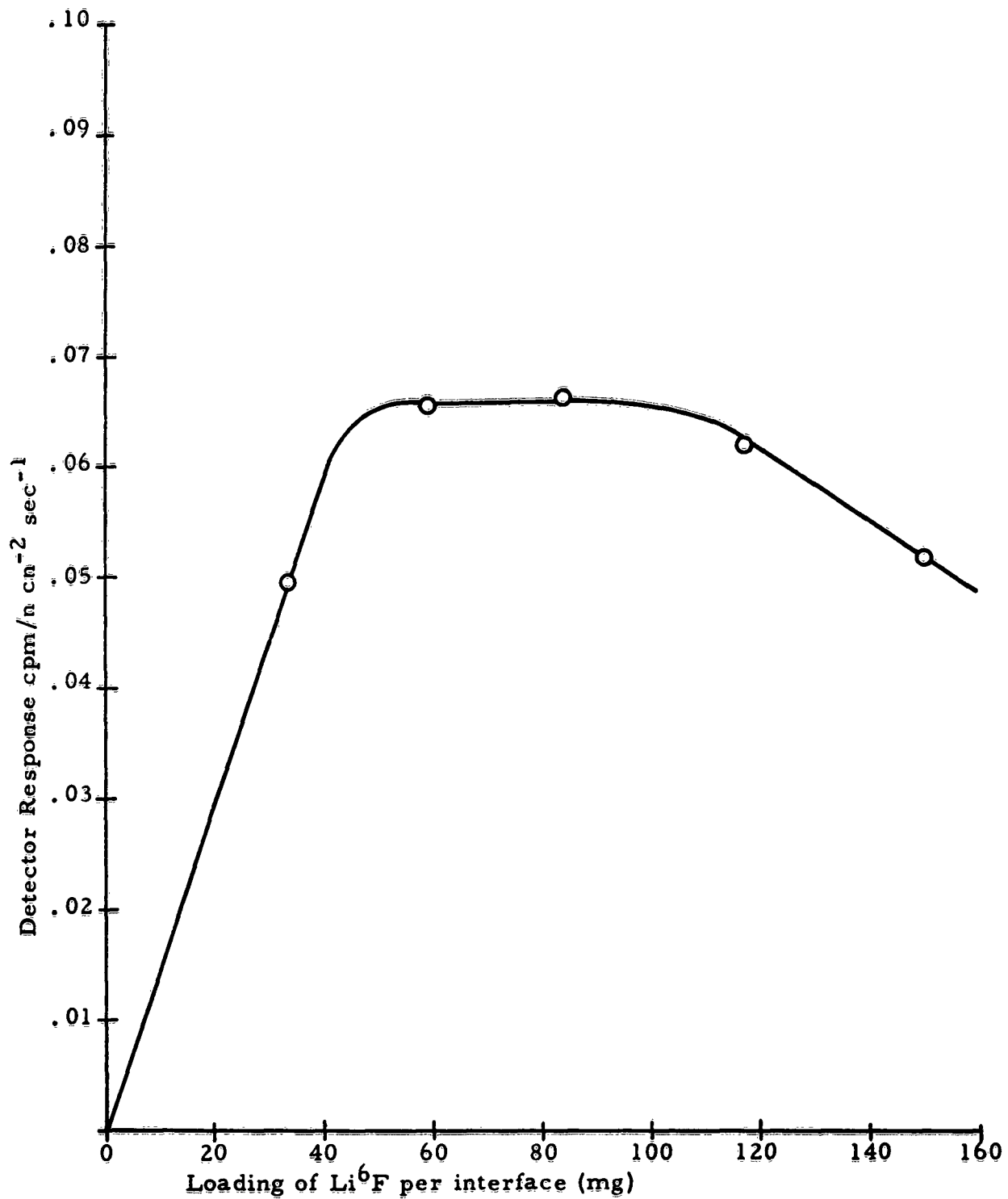

Figure 3. Neutron Detector Response at 1.24 Mev As a Function of Li⁶F Loading per Interface On 6 Interfaces.

TABLE 3

Thermal Neutron Measurements

Detector*	No. of Holes** in B ¹⁰ -Mn-Ti Shield	Gamma Bias	Thermal Neutron Flux	Detector Counts Per Minute	Response c/m//n cm ⁻² sec ⁻¹	Ratio*** 1 Mev/ Thermal		
200/33.5	0	2 R/hr.	2.25 x 10 ⁴ n cm ⁻² sec ⁻¹ (Cd ratio = 1000 with 10 mils Cd, 5 mils In.)	266	.0117	250		
	4			335	.0147	200		
	8			541	.0238	123		
	16			650	.0286	100		
350/59	0					473	.0210	185
	4					535	.0238	160
	8					610	.0271	140
	16					690	.0307	125
500/84	0					588	.0262	150
	4					706	.0314	126
	8					854	.0380	100
	16					983	.0436	90
700/117	0					610	.0270	137
	4					716	.0317	117
	8					775	.0346	107
	16					995	.0442	84
900/150	0			312	.0139	224		
	4			555	.0246	127		
	8			784	.0348	90		
	16			969	.0430	72.5		
480/60	0				Not exceed .03			
600/60	0				Not exceed .04			

* Total Li⁶F loading on 6 interfaces/loading per interface.

** PM Tube and base was covered with 20 mils Cd.

*** Desired ratio of 1 Mev/Thermals = 36.

response of the detectors is slightly higher than desired and by drilling holes in the B^{10} -Mn-Ti shields to obtain the desired thermal neutron response also increases the intermediate neutron energy response. Therefore, by drilling several holes in the cadmium surrounding the PM tube, the desired thermal neutron detector response can be obtained without effectively increasing the intermediate neutron energy response.

3. Fast Neutron Energy Measurements

Fast neutron energy measurements were made with the USNRDL 2 Mev Van de Graaff in San Francisco, California. A number of detectors were constructed for the purpose of (1) adjusting the response at 15 Mev by eliminating ZnS(Ag) interfaces in the detector, (2) optimizing the response at one Mev by adjusting the Li^6F interface loading configuration, and (3) determine the overall response of the various detectors.

Fast neutron energy measurements of the previously submitted neutron detector indicated that the response was too high at 15 Mev. The mechanism for the response at 15 Mev is due to the neutron-proton elastic scattering which is detected by the ZnS(Ag) loaded interfaces. Figure 4 shows that one is able to reduce the detector response at 15 Mev by over a factor of 2 by the reduction of ZnS(Ag) interfaces, while the response at 1.24 Mev is reduced less than 20%. Thus, by eliminating ZnS(Ag) interfaces, the fast neutron energy response of the detectors can be flattened to the desired value. In other words, the rate of increase of detector sensitivity per unit flux for increasing neutron energy is reduced.

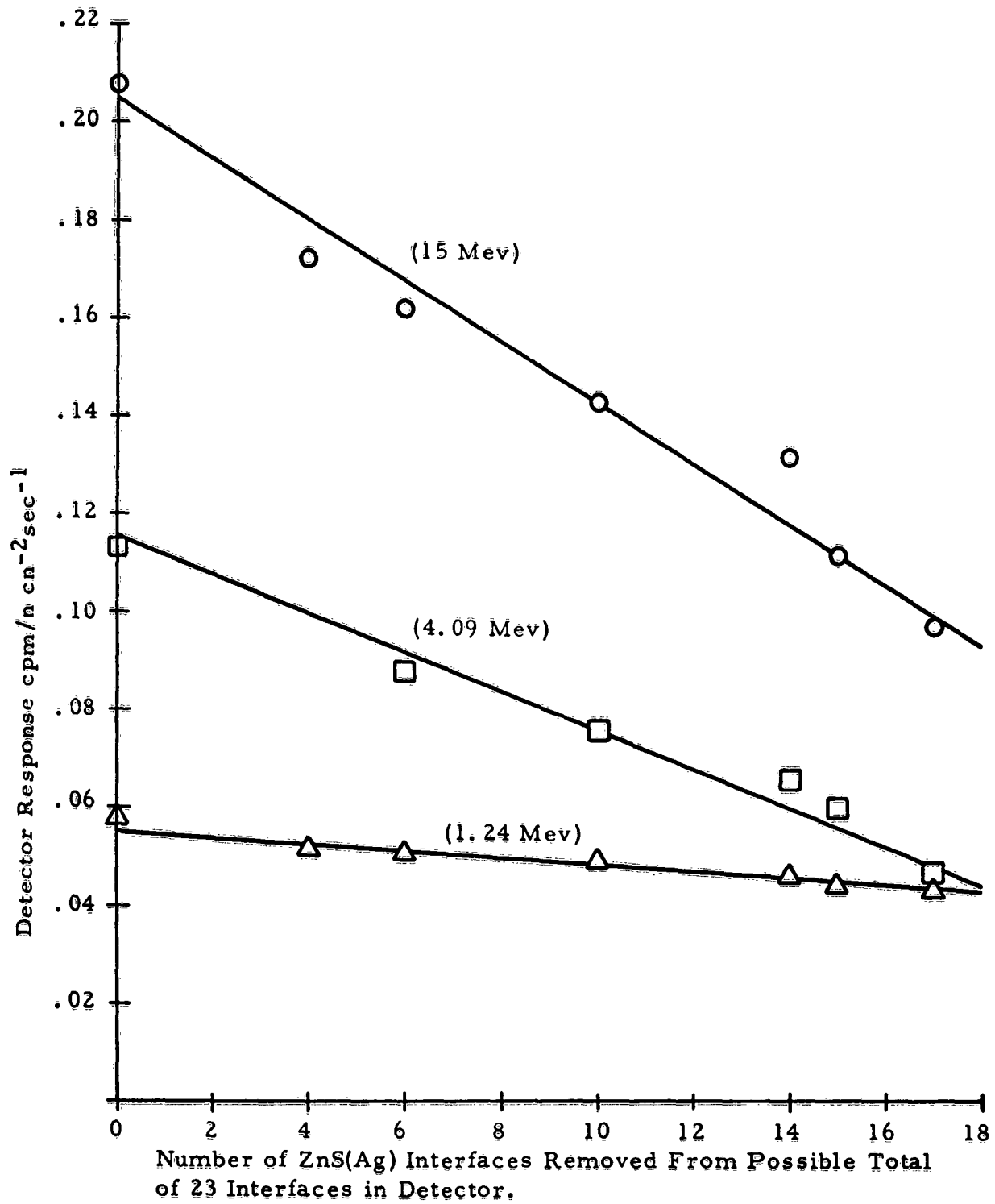

Figure 4. Neutron Detector Response As a Function of ZnS(Ag) Interfaces Removed For Various Neutron Energies.

Figure 5 shows that by increasing the number of interfaces loaded with 60 mg Li^6F , the detector response at one Mev increases some 60%. Therefore, the overall efficiency of the detector can be increased by increasing the number of interfaces loaded with Li^6F and still maintain enough sensitivity to adjust the thermal neutron response to the desired value.

For comparison purposes, Figure 6 shows the response curves for the Class I and II detectors. As Figure 6 indicates by proper positioning of the Li^6F interfaces, the response at one Mev can be increased. In addition, by the removal of $\text{ZnS}(\text{Ag})$ interface, the response at 15 Mev can be reduced and thus the detector closely matches the desired response curve.

The criteria for a choice of a neutron detector is one that will closely approach the desired energy response curve of NBS Handbook 63 and at the same time maintains high overall cpm/flux or cpm/mrem hr^{-1} sensitivity.

Of the Class II neutron detectors investigated, the one detector configuration that more closely meets the desired criteria is that detector loaded with a total of 600 mg Li^6F , 60 mg per ten interfaces and with no $\text{ZnS}(\text{Ag})$ loaded interfaces except those needed for the Li^6F loaded interfaces. The fast neutron dose rate response of this detector, as shown by Figure 7, matches the desired response quite well. In addition, the thermal neutron energy response can easily be adjusted to the desired value with the existing neutron shield. The overall sensitivity of the device is the highest of all the detectors investigated. Figure 8 shows the final neutron survey meter detector response as a function of neutron

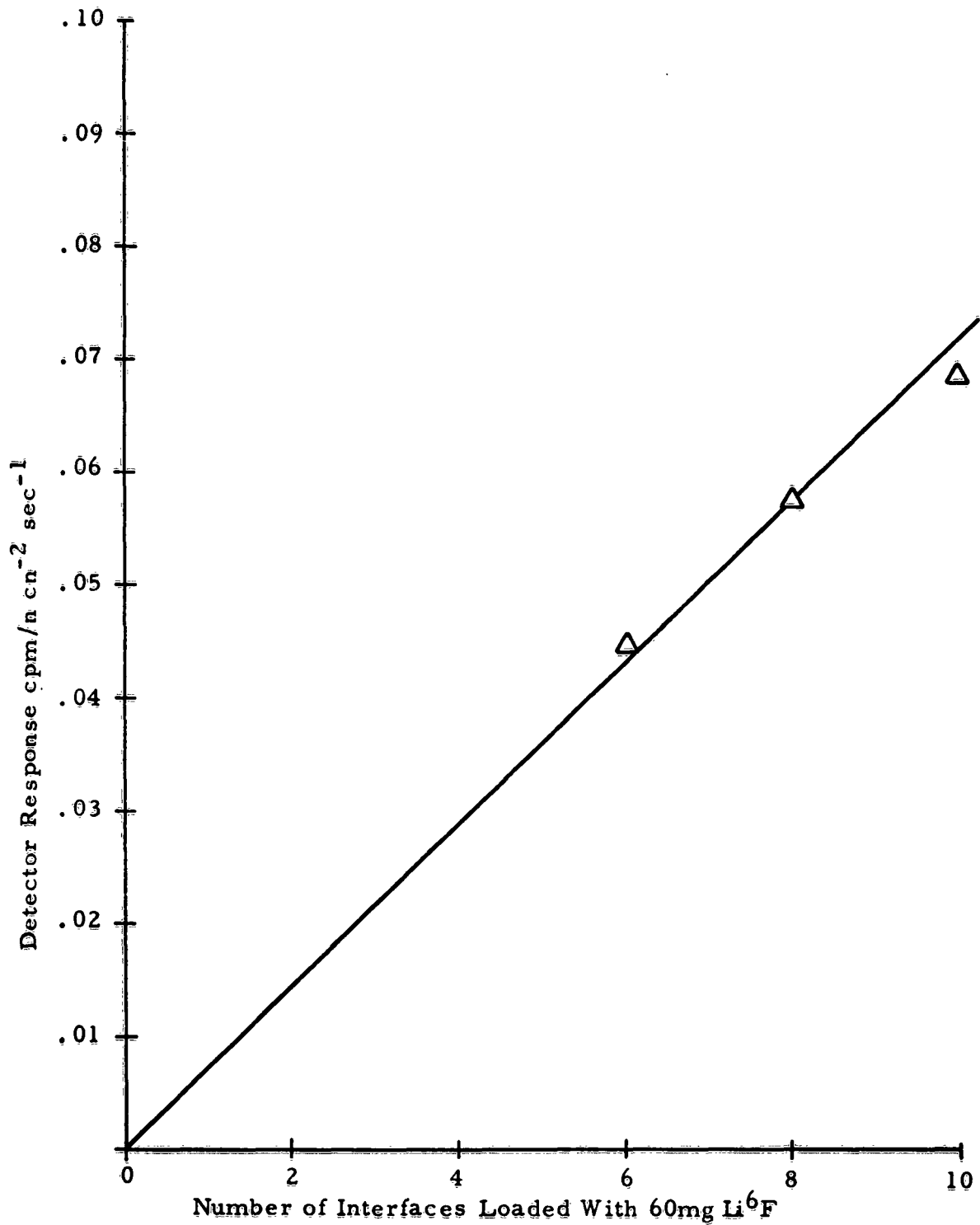
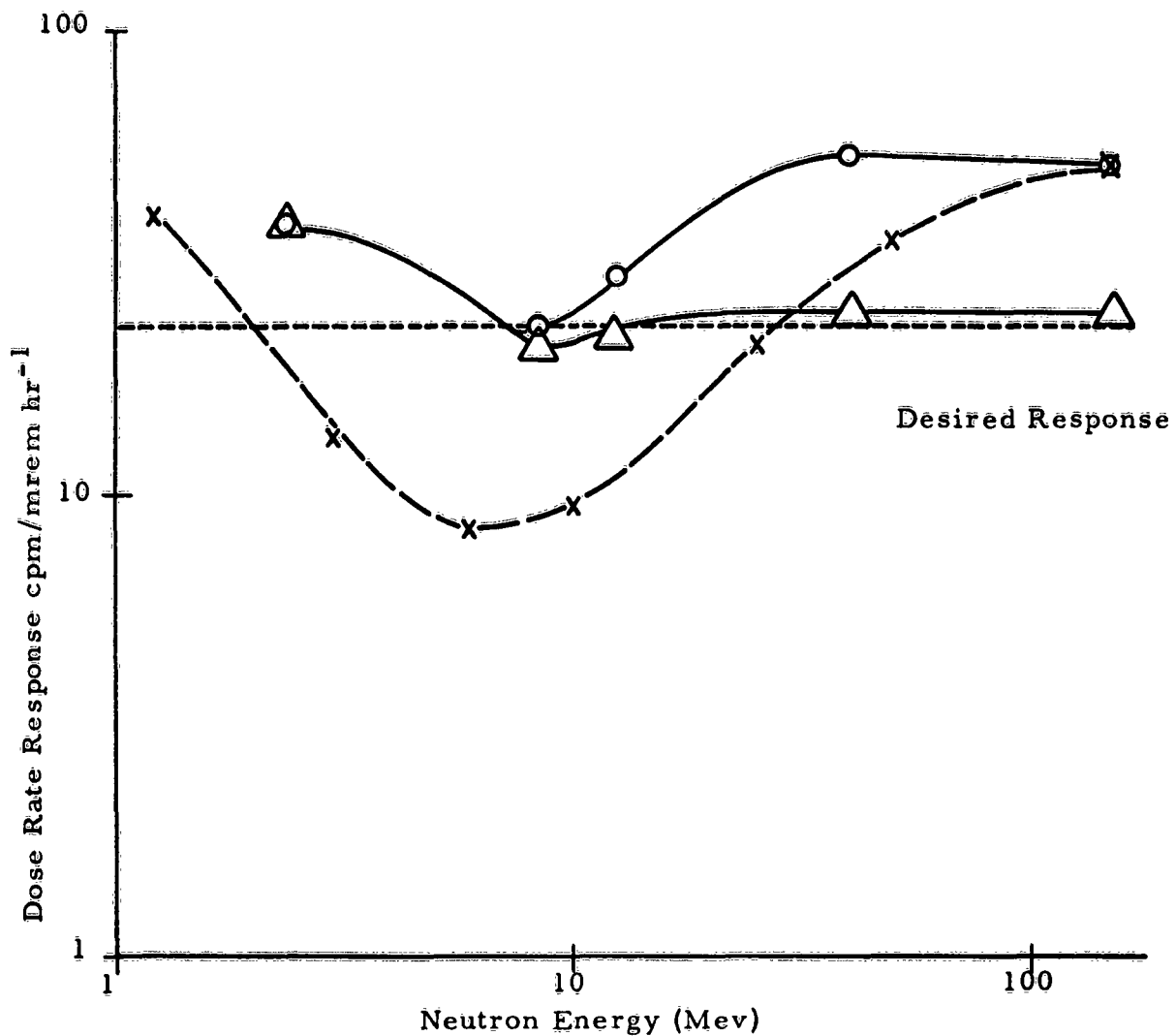
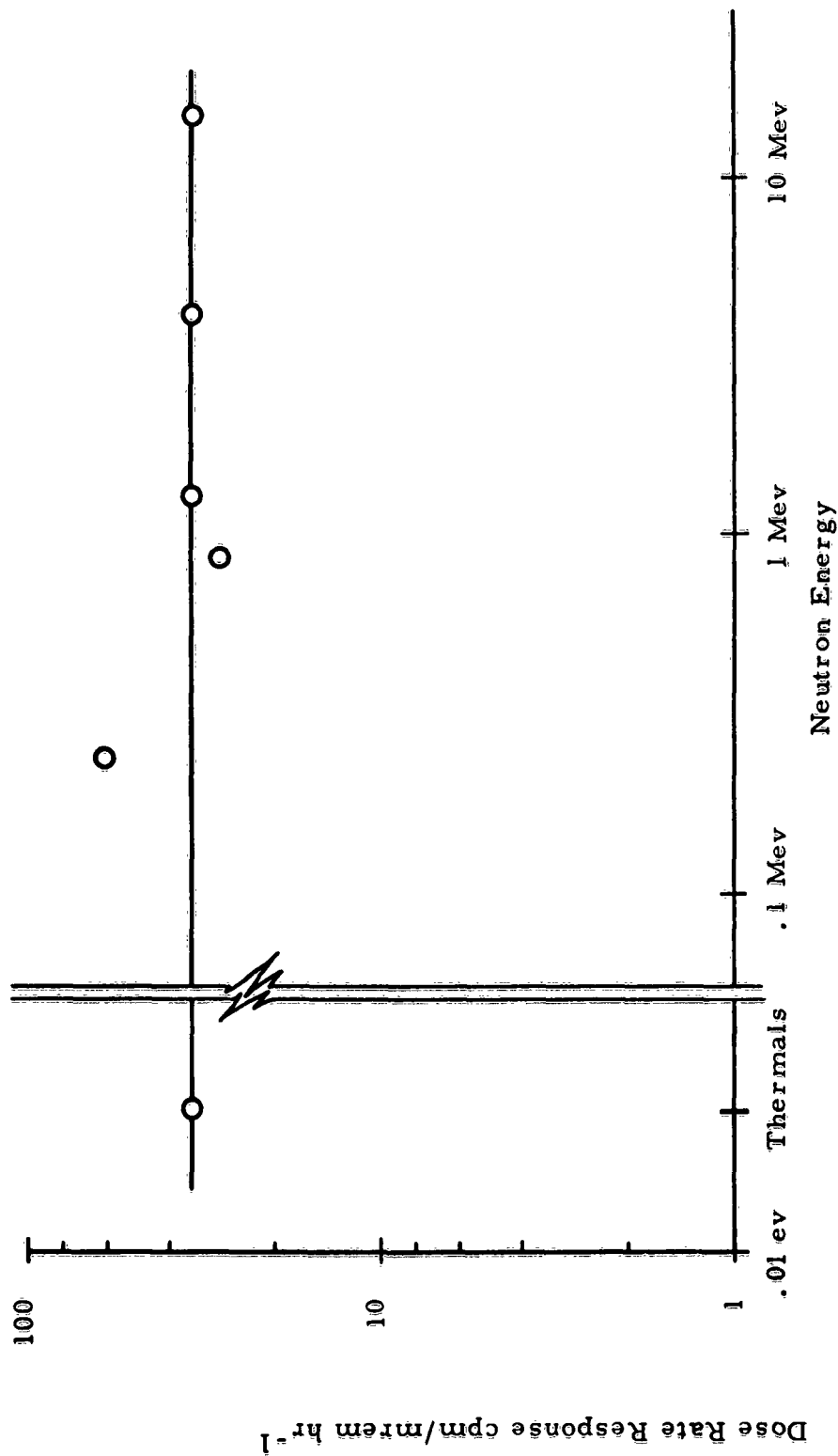

Figure 5. Neutron Detector Response at 1.24 Mev As a Function of 60 mg Li⁶F Loaded on Various Interfaces.



- Detector Response (350/59mg Li^6F per 6 interfaces - All interfaces loaded $15 \text{ mg}/\text{cm}^2$ $\text{ZnS}(\text{Ag})$)
- △ Detector Response (350/59mg Li^6F per 6 interfaces - 17 $\text{ZnS}(\text{Ag})$ interfaces removed)
- x NRDL measured response of old detector (300/100 mg Li^6F per 3 center interfaces - All 20 other interfaces loaded with $15 \text{ mg}/\text{cm}^2$ $\text{ZnS}(\text{Ag})$ Normalized at 15 Mev.

Figure 6. Dose Rate Response As a Function of Neutron Energy for Various Neutron Detectors.



○ (600/60 mg Li⁶F per 10 interfaces - 13 ZnS(Ag) Interfaces Removed)

Figure 7. Final Detector Dose Rate Response As a Function of Neutron Energy.

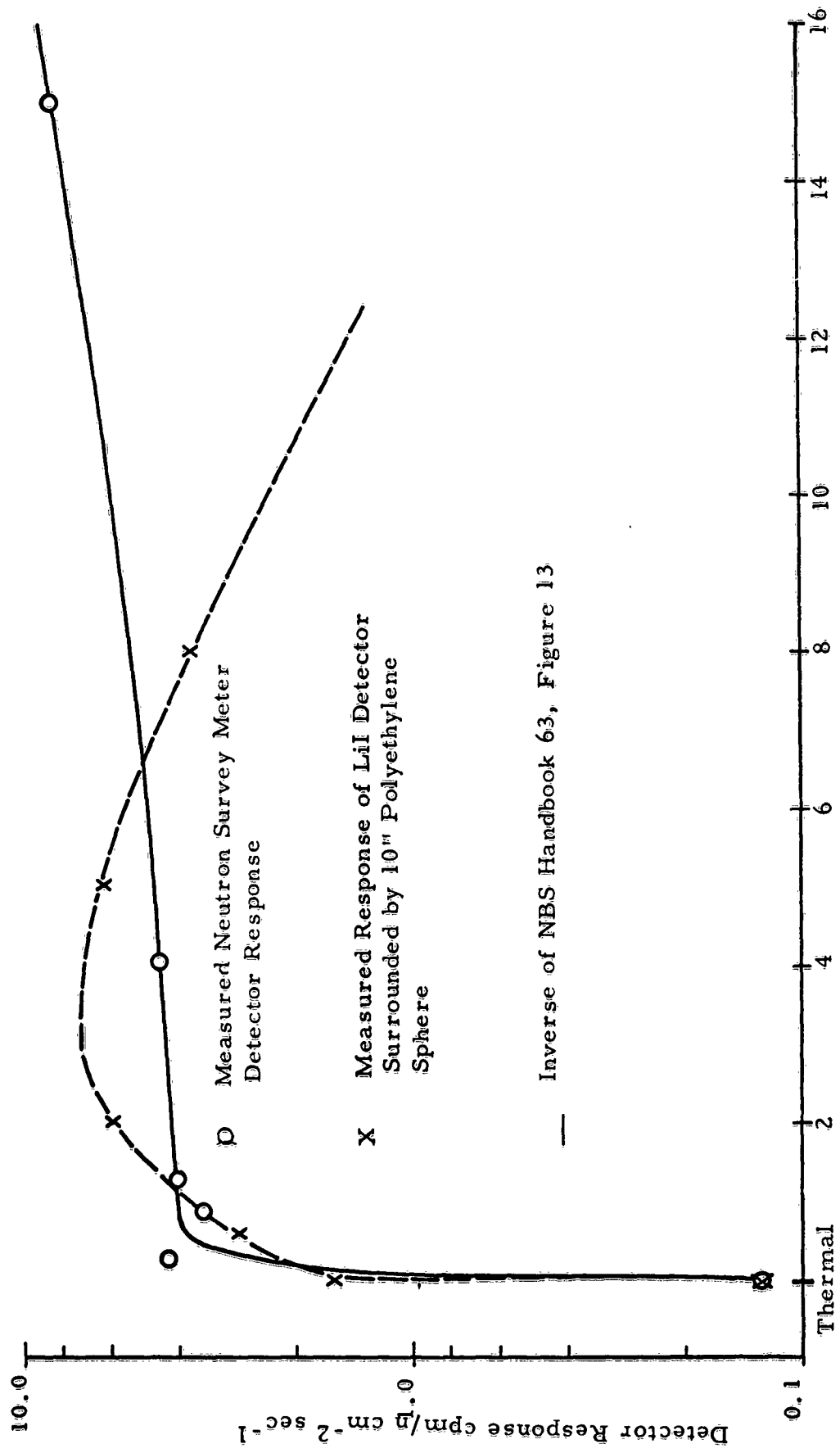

Figure 8. Neutron Survey Meter Detector Response vs Neutron Energy Compared To the Ideal Neutron Detector Response and a 10" Polyethylene Sphere Response.

energy compared to the desired response curve. For comparison, the response of a 10" polyethylene sphere using a LiI detector* is shown.

To get an idea of how the neutron detector will respond to identical dose rates from sources of different neutron spectra, two USNRL neutron sources (PuBe with an average energy of 4.5 Mev and PuF₄ with an average energy of 1.25 Mev) were monitored with several neutron detectors positioned such as to receive the same dose rates from both neutron sources. As Table 4 indicates, by reducing the number of ZnS(Ag) interfaces and increasing the Li⁶F loading, the detector can be made to respond properly to both spectra.

TABLE 4

Response of Detectors in cpm/mrem hr⁻¹ For PuBe & PuF₄ Neutron Sources

Detector	cpm/mrem hr ⁻¹ For PuBe Neutrons	cpm/mrem hr ⁻¹ For PuF ₄ Neutrons	PuBe/PuF ₄ Response Ratio (Desired ratio 1.05)
350/59 (1)	48.0	27.3	1.76
350/59 (2)	29.5	21.2	1.39
600/60 (3)	41.0	35	1.17

- (1) All interfaces (17) other than Li⁶F loaded with mg/cm² ZnS(Ag)
 (2) Three interfaces between Li⁶F loaded interfaces loaded with 15 mg/cm² ZnS(Ag)
 (3) Three interfaces between Li⁶F loaded interfaces loaded with 15 mg/cm² ZnS(Ag)

NOTE: The detector listed as 600/60 is not the final neutron detector in that the final detector had no interfaces loaded only with ZnS(Ag).

* D. E. Hankins: A Neutron Monitoring Instrument Having A Response Approximately Proportional To the Dose Rate From Thermals to 7.0 Mev. LA-2717, August 20, 1962.

Finally, in comparing the overall detection sensitivity of the AN/PDR-58 to other neutron monitoring instruments one observes, as shown by Table 5, that the "58" is about a factor of 10 higher in sensitivity than the Hurst fast neutron dosimeter. And, with the exclusion of the long counter, which is not a portable instrument, the "58" is comparable in detection sensitivity to the other monitoring instruments.

TABLE 5

Comparison Of Various Neutron Monitoring Instruments

<u>Instrument</u>	<u>Response (cpm/mrem hr⁻¹)</u>	<u>References</u>
Hurst Type Proton Recoil Dosimeter ⁽¹⁾	3.5	RSI, 22, 12, pg. 981, Dec., 1951
NRDL Long Counter ⁽²⁾ (not portable)	670	Measured
Nuclear-Chicago DN-3	37.	Measured
10" Polyethylene Sphere ⁽⁴⁾ (not portable)	56	LA-2717, Aug. 1962
AN/PDR-58 (XN-1) Neutron Survey Meter ⁽⁵⁾	34	Measured

(1) For Neutron energies from 0.5 - 10 Mev

(2) For Neutron energies from 0.1 - 8 Mev

(3) For PuBe Neutron source

(4) For Neutron energies from .025 ev (thermals) - 6 Mev

(5) For Neutron energies from .025 ev (thermals) - 15 Mev

4. Neutron Survey Meter Circuit Modifications

During the final phase of this contract period the electronics of the neutron survey meters were investigated. Prior to this investigation, it was believed that

the meter electronics were performing satisfactorily, due to the favorable report from the National Bureau of Standards who used one of the instruments for a period of some five months with satisfactory performance. However, in reviewing the electronics it was observed that the signal-to-noise-ratio at the input to the amplifier was poor. This difficulty arose from the fact that the noise was about a factor of 10 higher than gamma ray signals from 2 R/hr Cs 137. setting the discrimination level to bias out the noise reduced the neutron sensitivity of the instrument since neutron signals with amplitudes between the gamma level and noise level were lost. Laboratory investigations revealed that the noise was being produced and radiated to the amplifier input by the power supply. Since available space between circuit boards precluded shielding the power supply, the only feasible means of eliminating this undesirable feature without major circuit modification was to place a voltage preamplifier in the probe so as to raise the amplitude of the phototube signal to a level greater than the power supply noise at the input to the main amplifier. The schematic of the preamplifier put in the probe is shown in Figure 9. Capacitors C 301 through C 304 were changed to disc ceramic units to allow for more compactness. 2N335 and 2N1131 transistors were used in the preamplifier due to the fact that 2N338 and 2N1026 transistor units could not be obtained in time. 2N338 transistors are superior to the 2N335 units in this application. The single wire coaxial cable was replaced by a 2-wire coaxial cable so that B/ could be supplied to the preamplifier.

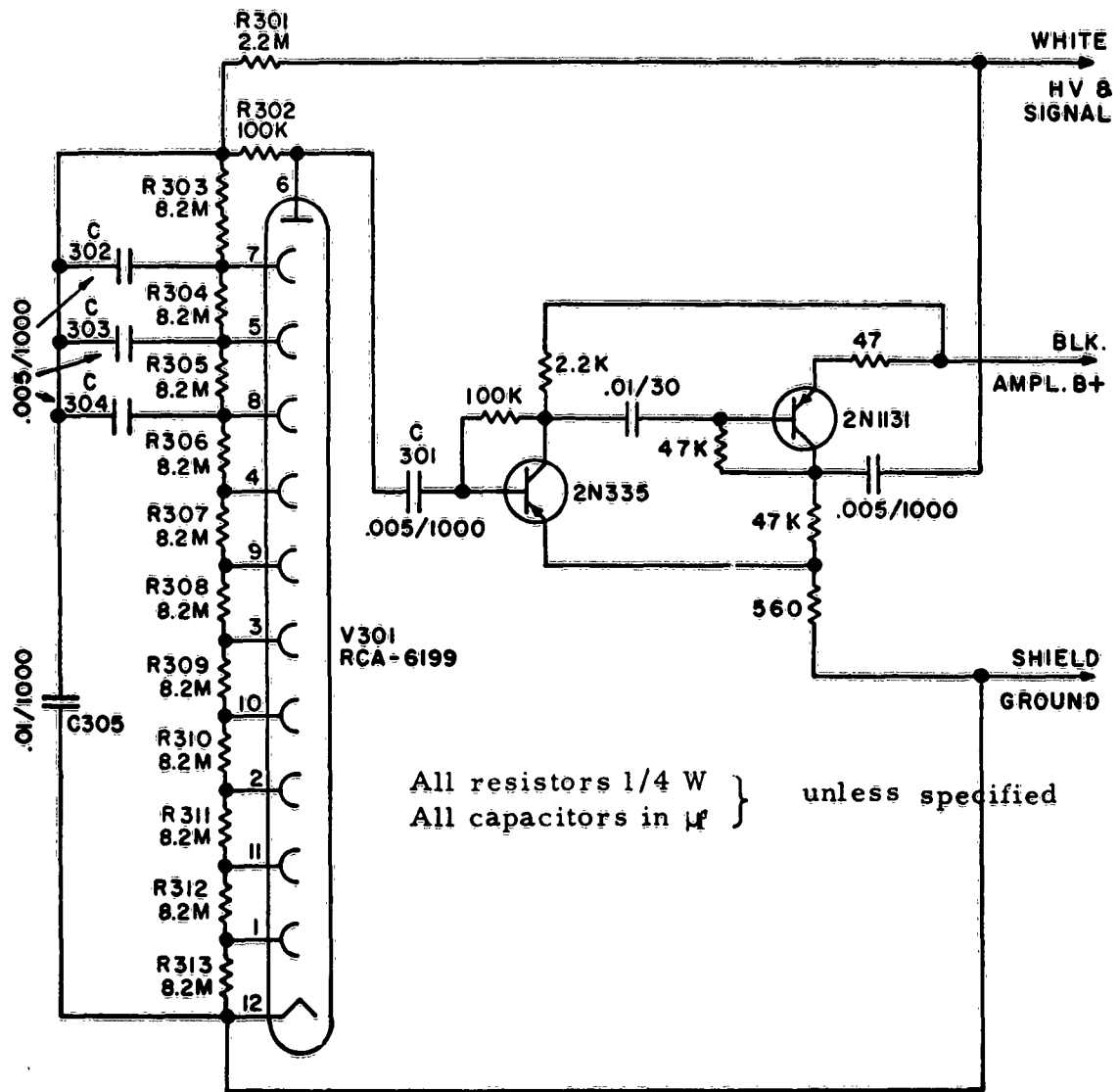

Figure 9. Neutron Survey Meter Probe Schematic.

When the units were reassembled, the gain of the main amplifier was excessive. Reduction of the main amplifier's gain was accomplished by the elimination of the first amplifier pair in the main amplifier. The new main amplifier reassembly is shown by Figure 10. However, due to the lack of time, optimization of the main amplifier was not accomplished.

The second major problem area was inadequate damping of the 5 and 50 range on the meter. Increased meter damping was accomplished by changing the original single-stage averaging circuit to a three-stage averaging circuit. This change necessitated the changing of Q201 from 2N697 to 2N2049 due to the inadequate gain of 2N697. These changes, depicted in Figure 11, seemed to provide satisfactory damping to the various ranges of the meter.

Other minor changes to the meter circuit included a change of R101 from 32.4K to 84.5K for proper battery check. In addition, to reduce the power supply noise level capacitor C105 was changed from 70 μ t to 180 μ t . A .15 μ t capacitor was placed from terminal 5 of the pulse transformer to ground and critical signal wiring in the meter were shielded.

With the present modifications, the units perform a degree better than previously. However, with other minor optimization modifications, it is believed that the units can be made to perform much more satisfactorily.

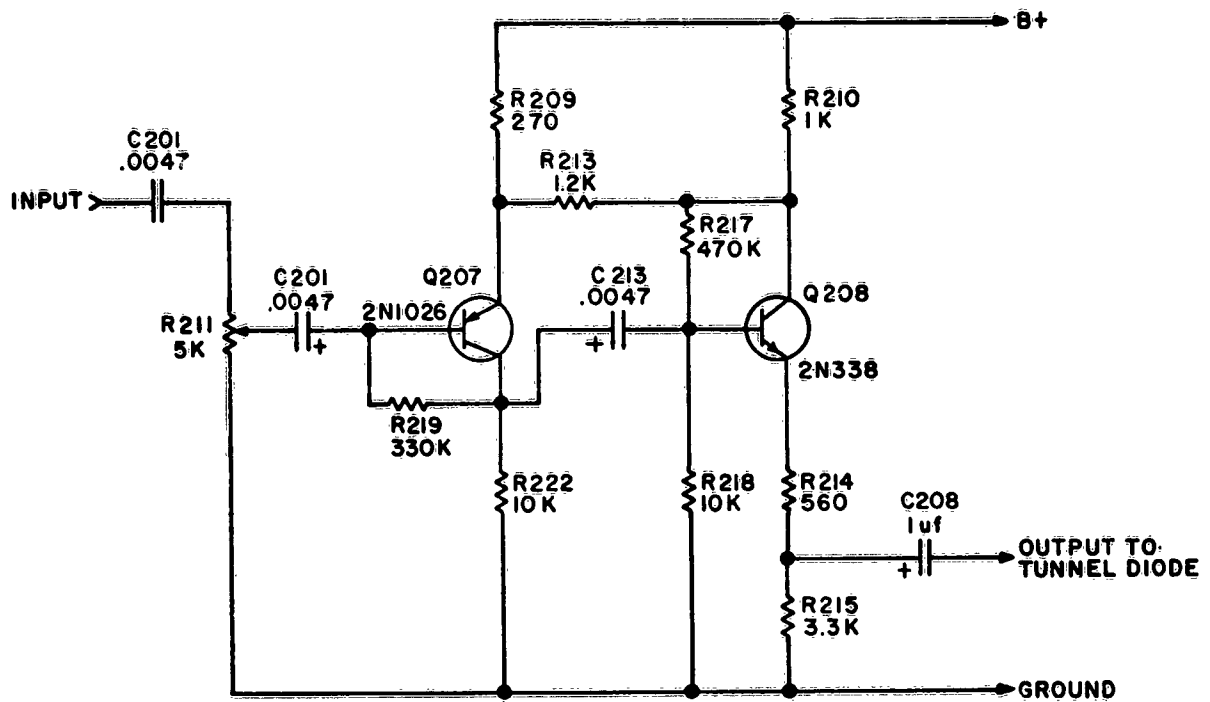

All resistors 1/4 watts

Figure 10. Neutron Survey Meter Main Amplifier Schematic.

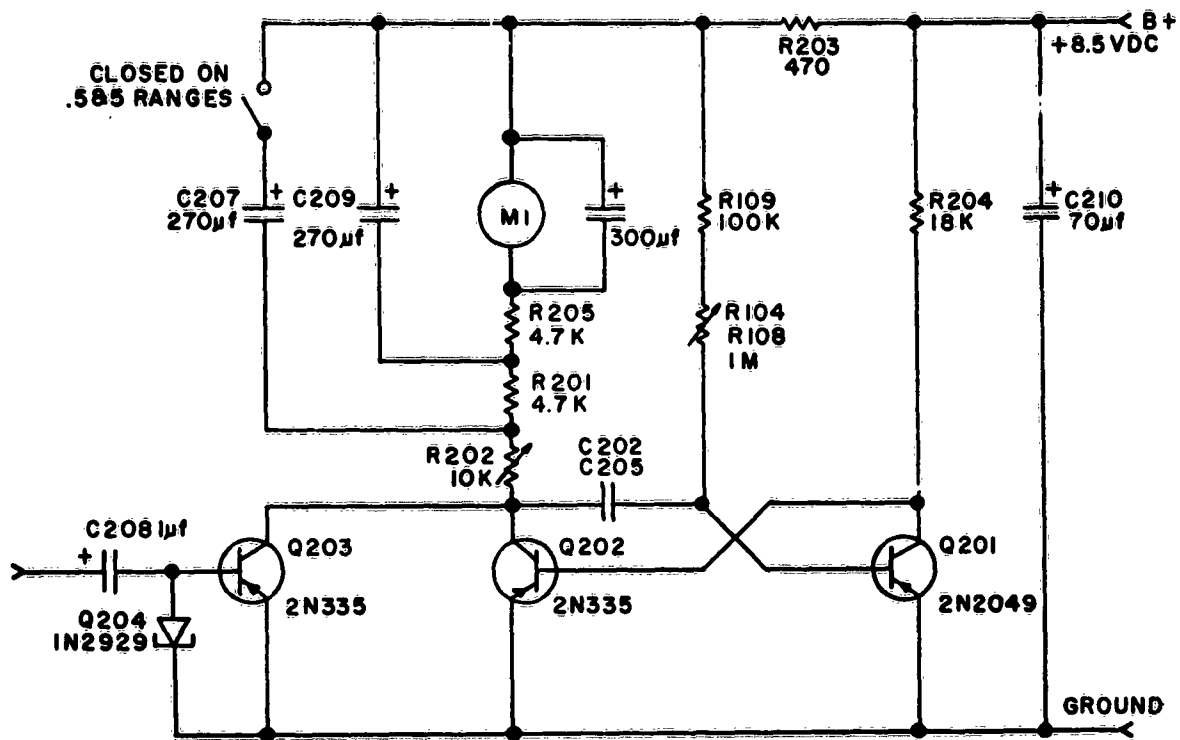

All resistors 1/4 W } unless specified
 All capacitors in μf

Figure 11. Circuit Modifications of One Shot Multivibrator

D. CONCLUSION

The fast neutron energy response of the "new" neutron detector has successfully been made to match the desired value by proper positioning and increasing the loading of Li^6F and by eliminating certain $\text{ZnS}(\text{Ag})$ loaded interfaces in the detector. In addition, the desired thermal neutron response can be obtained by surrounding the AN/PDR-58 probe phototube with cadmium and drilling several holes in the cadmium. Also, the overall sensitivity of the "new" detector has been increased by a factor of 3 over the old detectors.

The meter damping circuit has been improved, and needed modifications have been made in the amplifier. However, due to the lack of time these meter amplifier modifications were not optimized, but with a few minor circuit changes, they can be made to perform more satisfactorily.

The instruments, even as they stand now, definitely represent an advancement in the state-of-the-art of neutron radiation hazards monitoring.

At the present time, two types of neutron monitoring instruments are in general use: the thermal-neutron monitor for neutrons with energies below 0.5 ev, and the fast-neutron monitor for neutrons in the energy range 0.2-10 ev. It is impossible to make an accurate determination of the neutron dose rate hazard to personnel in the vicinity of a nuclear reactor with these instruments without sufficient knowledge of the existing neutron energy spectra and flux.

However, with the AN/PDR-58 (XN-1) neutron survey meter, a person, without any prior knowledge about nuclear physics or the reactor facility to be monitored, except his tolerable neutron dose rate level, could quickly and accurately establish the existing background neutron biological dose rates around the facility. This is especially important when one is concerned with shipboard reactors, where any nuclear accident or damage to the reactor vessel would require quick and accurate hazards analysis. This can be accomplished satisfactorily with the presently designed AN/PDR-58 (XN-1) neutron survey meter.

PART II
RECOMMENDATIONS

It is recommended that action be initiated to prepare for production of the AN/PDR-58. This includes circuit standardization.

Provisions should be made in the AN/PDR-58 for an earphone headset. The 0-0.5 mrem/hr range on the instrument should be eliminated, with substitution of an "integrate scale" to allow for better measurement of low dose rates.