

UNCLASSIFIED

AD 297 413

*Reproduced
by the*

ARMED SERVICES TECHNICAL INFORMATION AGENCY
ARLINGTON HALL STATION
ARLINGTON 12, VIRGINIA



UNCLASSIFIED

NOTICE: When government or other drawings, specifications or other data are used for any purpose other than in connection with a definitely related government procurement operation, the U. S. Government thereby incurs no responsibility, nor any obligation whatsoever; and the fact that the Government may have formulated, furnished, or in any way supplied the said drawings, specifications, or other data is not to be regarded by implication or otherwise as in any manner licensing the holder or any other person or corporation, or conveying any rights or permission to manufacture, use or sell any patented invention that may in any way be related thereto.

297413

CATALOGED BY ASTIA
AS AD NO.

PHILCO CORPORATION

Western Development Laboratories

In reply cite: 614-3-176
RWB/KRO/pjc
28 February 1963

SUBJECT: Contract AF04(695)-113
Submission of Technical Report WDL-2026
As a deliverable item

TO: Commander
Space Systems Division
Air Force Systems Command
United States Air Force
Air Force Unit Post Office
Los Angeles 45, California

ATTENTION: Technical Data Center

INFO COPIES: ASTIA, Arlington, Virginia (2 copies)
D. Cowart, CSD #3 (1 copy)
T. R. Treaper, AFSSD/SSOCK (w/o enclosure)

REFERENCE: (a) Contract AF04(695)-113, Exhibit "A"
(b) Section III, Paragraph 3.16 of AFBM Exhibit 58-1
(c) Paragraph 3.5.3 of AFSSD Exhibit 62-44A

In accordance with the requirements of references (a),
(b), and (c), we are forwarding ten (10) copies of the following docu-
ment:

	<u>Title</u>	<u>Number and Date</u>
MSAP	Phase A Human Engineering	WDL-TR2026
Plan		28 February 1963

PHILCO CORPORATION
Western Development Laboratories

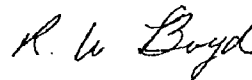

R. W. Boyd
Manager, Contract Management

TECHNICAL OPERATING REPORT

WDL-TR2026

28 FEBRUARY 1963

MSAP - PHASE A
HUMAN ENGINEERING PLAN

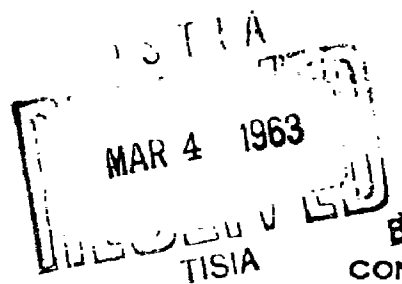

CONTRACT AF04(695) - 113

TECHNICAL OPERATING REPORT

MSAP - PHASE A
HUMAN ENGINEERING PLAN

Prepared by

PHILCO CORPORATION
Western Development Laboratories
Palo Alto, California

Contract AF04(695)-278

Prepared for

SPACE SYSTEMS DIVISION
AIR FORCE SYSTEMS COMMAND
UNITED STATES AIR FORCE
Inglewood, California

ABSTRACT

PHILCO WDL-TR2026
MSAP-PHASE A
HUMAN ENGINEERING PLAN

UNCLASSIFIED
47 pages
AF04(695)-278

This report describes the Human Engineering Program as it is currently applied to Phase A of the Multiple Satellite Augmentation Program (MSAP) of the Satellite Control Facility.

THIS UNCLASSIFIED ABSTRACT IS DESIGNED FOR RETENTION IN A STANDARD 3-BY-5 CARD-SIZE FILE, IF DESIRED. WHERE THE ABSTRACT COVERS MORE THAN ONE SIDE OF THE CARD, THE ENTIRE RECTANGLE MAY BE CUT OUT AND FOLDED AT THE DOTTED CENTER LINE. (IF THE ABSTRACT IS CLASSIFIED, HOWEVER, IT MUST NOT BE REMOVED FROM THE DOCUMENT IN WHICH IT IS INCLUDED.)

FOREWORD

The Technical Operating Report on Contract AF04 (695)-113 is submitted in accordance with Exhibit "A" of that contract and describes the Human Engineering Program as applicable in Phase "A" of the Multiple Satellite Augmentation Program.

This report is submitted in accordance with paragraph 3.16 of AFSSD 58-1, "Contractor Reports Exhibit", dated 1 October 1959, as revised and amended, and paragraph 3.5.3 of AF 62-44A, "Human Engineering for the Air Force Satellite Control System", dated 1 July 1962, and is an integral part of the Personnel Subsystem Test Evaluation (PST&E) Program.

TABLE OF CONTENTS

<u>Section</u>		<u>Page</u>
1	INTRODUCTION	1-1
	1.1 Purpose	1-1
	1.2 Scope	1-1
2	HUMAN ENGINEERING PROGRAM MANAGEMENT	2-1
	2.1 Program Description	2-1
	2.2 Organization	2-2
	2.3 Program Integration	2-5
3	PARTICIPATION IN SYSTEM ANALYSIS & DESIGN	3-1
	3.1 General Description	3-1
	3.2 Analysis of Overall Human Engineering Requirements	3-1
	3.3 Development of the Human Engineering Plan	3-2
	3.4 Analysis of Functions	3-2
	3.5 Allocation of Functions	3-3
	3.6 Design of Operational Management Structure	3-3
	3.7 Listing of Equipment for Task Analysis .	3-3
	3.8 Task Analysis	3-3
	3.9 Information Flow Analysis	3-4
	3.10 Specification of Subsystems Human Engineering Design	3-4
	3.11 Participation in MSAP Phase A System Analysis and Design	3-9
4	HUMAN ENGINEERING EQUIPMENT DESIGN	4-1
	4.1 General Description	4-1
	4.2 Listing of Equipment for Detail Design. .	4-1
	4.3 Design of Control/Display Equipment . . .	4-2
	4.4 Development of Static Mock-Ups	4-2
	4.5 Experiments Utilizing Dynamic Simulation	4-2
	4.6 Specification of Human Engineering Design for Equipment Procurement	4-3
	4.7 Functional Design of Communications Equipment	4-3
	4.8 Specification of Facilities Design . . .	4-3
	4.9 MSAP Phase A Human Engineering Equip- ment Design	4-8
5	HUMAN ENGINEERING DESIGN ASSURANCE	5-1
	5.1 General Description	5-1
	5.2 Design Assurance Procedure	5-1
	5.3 Design Review Requirements	5-4

TABLE OF CONTENTS (CONT'D)

<u>Section</u>		<u>Page</u>
6	HUMAN ENGINEERING ACCEPTANCE TEST AND DESIGN VERIFICATION	
	6.1 General Description	6-1
	6.2 Acceptance Test Procedure	6-2
	6.3 Design Verification	6-4
7	HUMAN ENGINEERING STUDIES	7-1
	7.1 Study Requirements	7-1
	7.2 Definition of Operational Requirements and Human Engineering Criteria for MSAP Follow-On Phases	7-1
	7.3 Prediction and Measurement of Human Engineering Design Performance	7-4
	7.4 Establishment of Man/Equipment Component Design Standards	7-6
	7.5 Application of Dynamic Simulation in Studies	7-8
8	HUMAN ENGINEERING SCHEDULE	8-1
	8.1 Schedule Review Procedure	8-1
	8.2 Milestone Schedule	8-1

LIST OF ILLUSTRATIONS

<u>Figure</u>		<u>Page</u>
2-1	Human Engineering Program	2-3
2-2	Philco WDL Organization	2-4
2-3	Integration of Human Engineering Program	2-6
3-2	Man/Machine Function List	3-6
3-3	Information Flow Analysis	3-7
3-4	Information Flow Analysis	3-8
4-1	Panel Layout Drawing	4-4
4-2	Control/Display Component List	4-5
4-3	Station Communication Plan	4-6
4-4	Facility Layout Drawing	4-7
5-1	Human Engineering Design Assurance Procedure (Part I)	5-2
5-2	Human Engineering Design Assurance Procedure (Part II)	5-3
6-1	Procedure for Deviation from Human Engineering Criteria	6-3
8-1	Human Engineering Milestone Schedule	8-2

SECTION 1
INTRODUCTION

1.1 PURPOSE

The Philco Western Development Laboratories (WDL) Human Engineering Program has been reoriented to provide compliance with AF/SSD Exhibit 62-44A "Human Engineering for the Air Force Satellite Control System," dated 1 July 1962. This program insures that the general principles of human engineering as outlined in AF/SSD Exhibit 62-44A, and further defined in MIL-STD-803, are implemented in Philco-developed ground electronic systems.

Human engineering is "the application of scientific knowledge concerning human performance to the establishment of requirements and to the design, development, evaluation and utilization of Air Force Systems."

The objectives of human engineering are: (a) "to assist in achieving system performance requirements by the appropriate use of man as a system component; (b) to select, design and develop equipment, procedures, work-environment and facilities to assure efficient, reliable and safe human performance (operate) within system tolerance limits; and (c) optimize demands upon manpower resources, man's skill, training, procedural-data and cost within the parameters established for the system."

1.2 SCOPE

This plan describes the Human Engineering Program as it is currently applied to Phase A of the Multiple Satellite Augmentation Program (MSAP) of the Satellite Control Facility.

The Human Engineering Program is implemented in conjunction with a separate Maintainability Program which is described in WDL-TR1708A, "Philco Western Development Laboratories Maintainability Program", dated 2 April 1962. The Maintainability Program insures that operational

requirements which depend upon maintainability characteristics are successfully achieved in Philco-developed ground electronic systems. The integration of the two programs is described in Paragraph 2.3 of this plan.

The MSAP Human Engineering Program is designed to achieve the objectives of the MSAP. These objectives are to increase the system capability and to simplify and standardize equipment and procedures within the Satellite Control Facility (SCF). Phase A of the MSAP provides additional equipment which will augment the SCF so that it can simultaneously support, from a single ground station, two satellites operating on either the VHF or UHF bands. Phase B of MSAP will up-date existing equipment and integrate these with equipment supplied under MSAP Phase A.

The MSAP has been in effect since February 1962 and all of the predesign and system design effort had been completed before AF/SSD Exhibit 62-44A became a compliance document for this program on July 18, 1962. Further, a portion of the equipment was designed previous to this date using Military Standard 803 (USAF) as a design guide. The extent of compliance with AFSSD exhibit 62-44A in the areas of equipment design and task analysis is defined in a letter report to AFSSD-SSOCO, "List of Equipment for Human Engineering Task Analysis and Detailed Design", dated September 18, 1962.

The following sections of this plan describe the program management, the analysis and design efforts, design verification, studies, and program review techniques. The human engineering system analysis and design phase is described completely although only parts of this effort were formally implemented during MSAP Phase A. The complete description is provided to define the process more accurately since it may be applied in the following phases of MSAP.

SECTION 2
HUMAN ENGINEERING PROGRAM MANAGEMENT

2.1 PROGRAM DESCRIPTION

The human engineering program consists of five interrelated areas of activity:

1. Participation in System Analysis and Design

The system analysis provides identification and definition of satellite control operation functions requiring human performance. The human engineering system design provides specification of human performance requirements at the sub-system level and establishes the system operational management structure.

2. Equipment Design

The design activity consists of selection, definition and detail design of equipment, procedures, and facilities (including work-environments) associated with satellite control functions requiring human performance.

3. Design Assurance

The design assurance activity comprises a continuous review of specifications, drawings, and program office change orders to assure that the design complies with the established human engineering criteria. Liaison is maintained with equipment designers to provide human engineering design guidance.

4. Design Verification

Design verification consists of participation in acceptance testing in order to verify human engineering design of equipment; and participation in system test and evaluation to verify human engineering design of system procedures, work-environments and facilities associated with satellite control functions requiring human performance.

5. Studies and Experiments

The studies and experiments include laboratory and field tests related to the development of the Air Force Satellite Control System.

The overall human engineering program activity sequence and relationships are illustrated in Fig 2-1.

2.2 ORGANIZATION

The organizational structure of Philco WDL is shown in Fig. 2-2. Human engineering is the primary responsibility of two engineering groups within the Man/Machine Design Section. These groups, the Analysis and Planning Group and the Design Group, receive general engineering assistance from the Support Engineering Group. The responsibilities of the three groups in the Man/Machine Design Section are described below:

1. Analysis and Planning Group

The Analysis and Planning Group is responsible for the following:

- a. Planning human engineering programs.
- b. Participating in system analysis and design (see Section 3).
- c. Developing acceptance test criteria and design verification plans (see Section 6).
- d. Identifying, planning, and/or executing studies and experiments necessary to support system human engineering (see Section 7).

This group works in close cooperation with program engineering, subsystem engineering, and maintainability personnel. It is primarily responsible for establishing the control/display design at system level including allocation of functions and determination of operating management structure. The final design product of this group is the human engineering data for subsystem performance specifications.

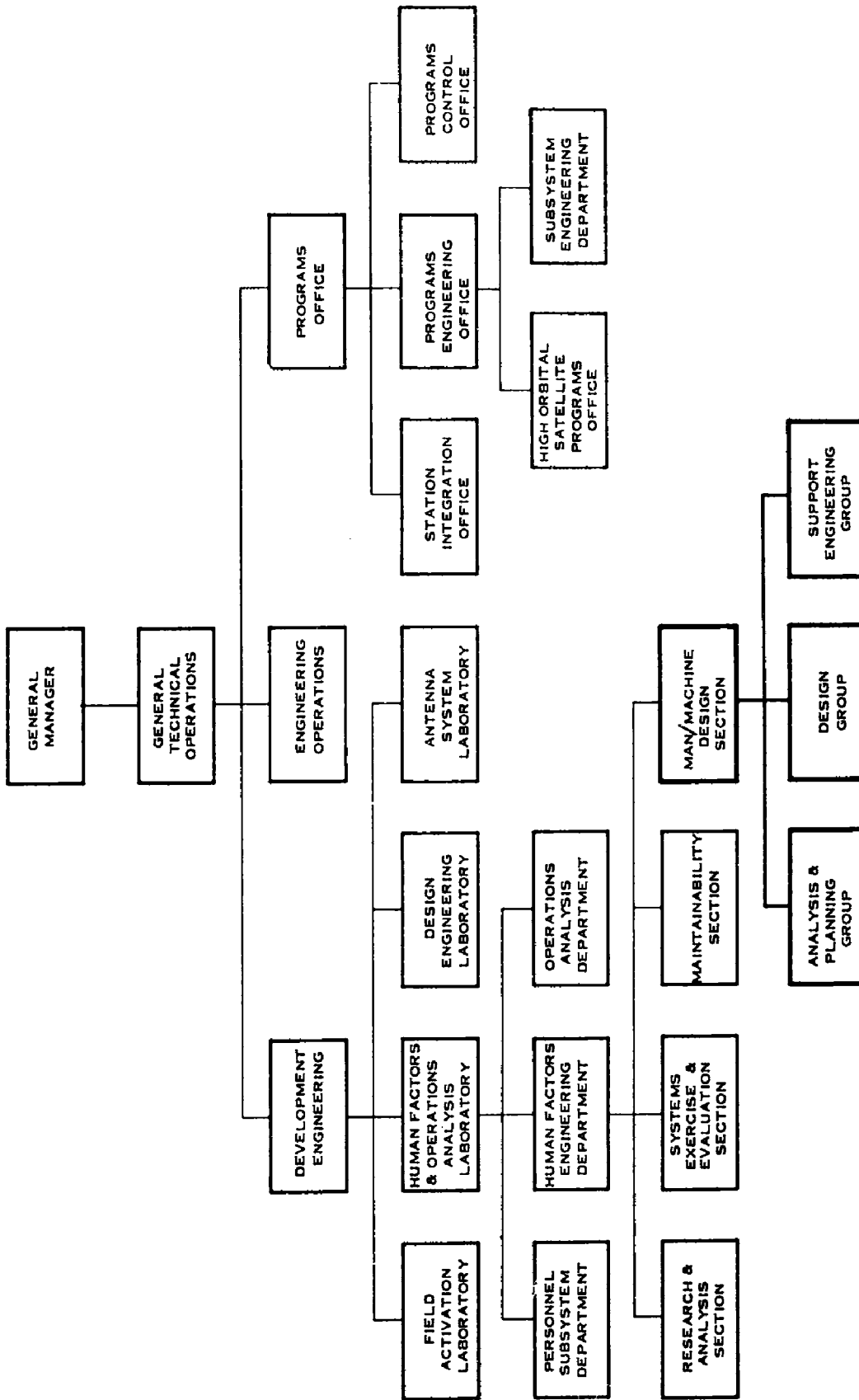

DWG 812713

Fig. 2-2 Philco WDL Organization

2. Design Group

The Design Group is responsible for the following:

- a. Detailed design of equipment selected for human engineering design (see Section 4).
- b. Design assurance covering equipment, facility, and computer program interfaces with operating personnel (see Section 5).
- c. Identification, planning, and/or execution of studies and experiments necessary to support equipment human engineering (see Section 7).

The Design Group is primarily concerned with control/display equipment development. The group designs selected control/display panels and mockups of critical operating positions. During the design assurance effort this group is responsible for review and sign-off of procurement specifications, rack elevation drawings, equipment layout drawings and panel layout drawings. Also, human engineering design guidance is provided to the equipment designers.

3. Support Engineering

The Support Engineering Group is responsible for the development of all instrumentation required in the Human Factors and Operations Analysis Laboratory. Under the Human Engineering Program, this group is responsible for the design, fabrication, and/or procurement of dynamic simulation equipment for use in studies and experiments.

2.3 PROGRAM INTEGRATION

The purpose of program integration is to achieve effective coordination between the human engineering effort and other MSAP efforts. Integration is achieved through the use of standardized procedures for distribution, review, and approval of program management and technical data. The integration of the Human Engineering Program is diagrammed in Fig. 2-3. The integration is shown in terms of information flow between the various MSAP functions which interface with the Human Engineering Program.

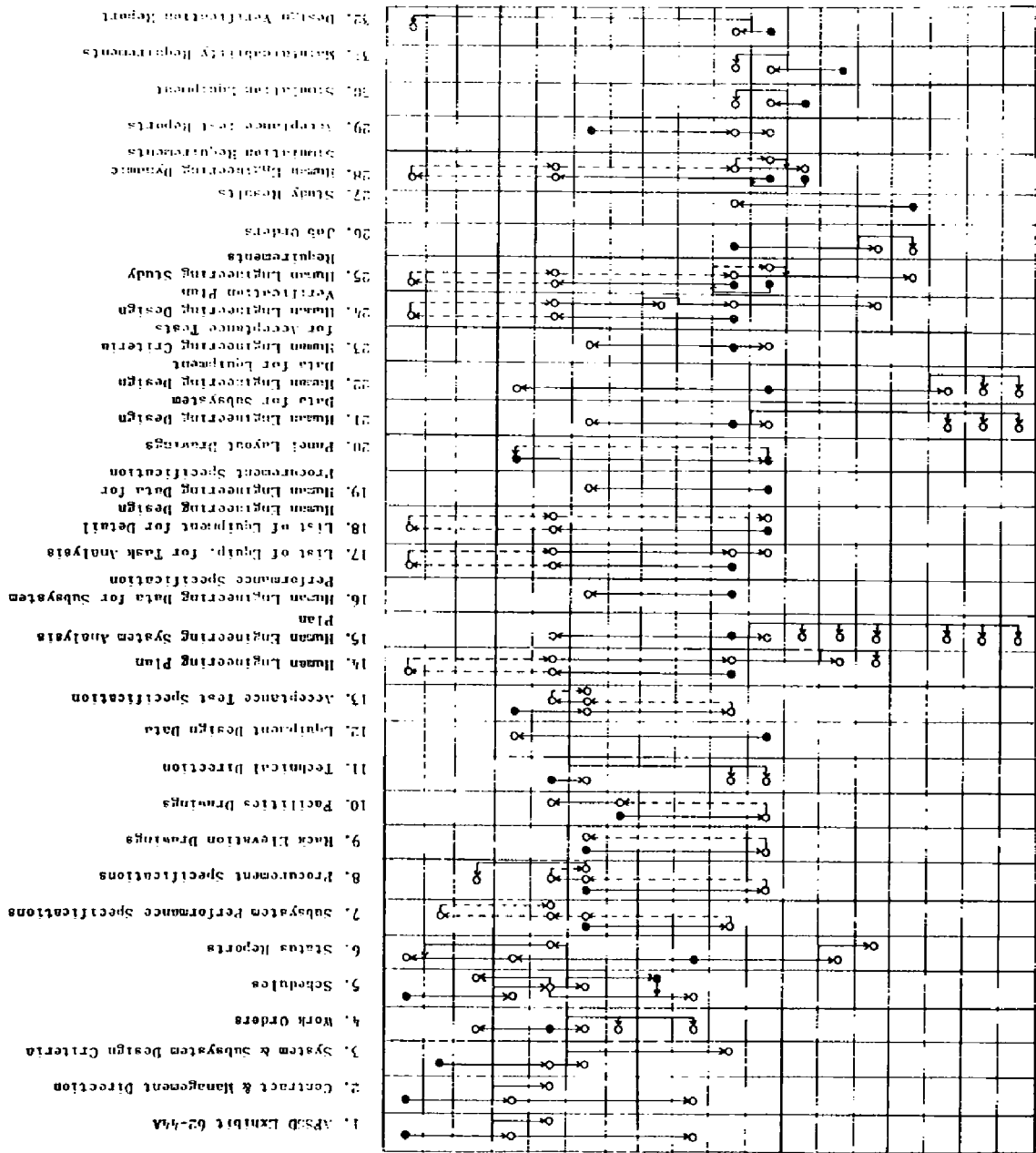

NOTES:
 ● = Originator
 ○ = Receiver
 --- = Approval at Organization Line Leaves

Fig. 2-3 Integration of Human Engineering Program

SECTION 3 PARTICIPATION IN SYSTEM ANALYSIS & DESIGN

3.1 GENERAL DESCRIPTION

Human engineering participation in system analysis and design assures that a human engineering design is established and specified at system and subsystem levels. The analyses performed by human engineering include analysis of overall human engineering requirements, analysis of system functions, allocation of functions, identification of equipment for task analysis, task analysis, and information flow analysis. The design oriented tasks include the development of the human engineering plans, design of the operational management structure and specification of subsystems human engineering design. The following paragraphs describe the analytical and design tasks and relate these tasks to the system development cycle.

The system analysis and design phase begins with the receipt of design criteria from Aerospace Corporation and ends when Aerospace Corporation approves the subsystem performance specifications. During this interval, the design criteria are translated into subsystem performance specifications and decisions are made as to off-the-shelf procurement versus new development. Human engineering participation here further assures that equipment procurement decisions reflect the most efficient man-machine design within the initial cost and schedule constraints of the system.

3.2 ANALYSIS OF OVERALL HUMAN ENGINEERING REQUIREMENTS

This initial step of the system analysis process established general criteria for human engineering design and the scope of the program to be executed. The data analyzed during this step includes the system and subsystem design criteria, operational requirements of the programs to be supported, and contractual direction from AF/SSD including schedules, procurement directions, and funding. The program operational requirements are analyzed to determine the expected types, frequencies, accuracies, and durations of the services to be

provided for each flight program. These data are not available in the design criteria, but must be researched from operations planning documentation such as System Test Objectives (STO's) and from historical data such as flight test reports. The end products of this step include the following:

1. Human Engineering Criteria for System Design

A statement of human engineering design objectives including the expected service loads (mission profiles), control/display concept, standardization goals, and general qualifications of the operating personnel.

2. Human Engineering Task Description

The human engineering task description is a detail description of tasks to be performed by the human engineering effort. The task description is supplemented by a milestone schedule and a funding estimate.

3.3 DEVELOPMENT OF THE HUMAN ENGINEERING PLAN

The Human Engineering Plan is developed from the human engineering task description in accordance with the format specified in AF/SSD Exhibit 62-44A. This plan is tailored to Philco WDL Management procedures and to the human engineering criteria for system design.

3.4 ANALYSIS OF FUNCTIONS

Functions to be performed by each subsystem, as specified in the subsystem design criteria, are identified and described in terms of their relationship and performance requirements. A system flow diagram is prepared to show the relationship of the functions and a list identifying and describing each function is prepared. The flow diagram and the function list are updated and detailed as subsystems design becomes more definite.

3.5 ALLOCATION OF FUNCTIONS

Allocation of functions to man/equipment combinations is accomplished by comparing performance requirements with performance capabilities of man versus equipment. Accuracy, time, frequency, and load parameters are particularly compared to determine the most efficient design approach for satisfying system performance requirements. The allocation of functions may require a detailed analysis of tasks and probable contingencies and a detailed review of the expected service loads. The end product of this step is a list showing the allocation of functions to man/machine combinations.

3.6 DESIGN OF OPERATIONAL MANAGEMENT STRUCTURE

The design of the operational management structure allocates the man/equipment functions to operating positions and establishes the information flow requirements between the operating positions. The operational management structure is validated by performing a task analysis and an information flow analysis.

3.7 LISTING OF EQUIPMENT FOR TASK ANALYSIS

The listing of equipment for task analysis is performed after the operational management structure is established and operating positions are identified. Equipment identified for task analysis includes only the equipment at those operating positions that are critical in terms of task, time, accuracy or load factors. The list is submitted via the MSAP Office to AF/SSD in accordance with Exhibit 62-44A.

3.8 TASK ANALYSIS

Task analysis is an extension of system functional analysis. The objective of task analysis is to validate the allocation of functions to operating positions and to provide more detailed criteria for control/display design at these positions. The task analyses are updated when required as the subsystem and equipment designs become

better defined. Task analysis aids in determining the sequence, logic, tolerance, and frequencies of tasks. The sequence and logic of the tasks is analyzed by means of a decision-action flow diagram illustrated in Fig. 3-1. The task, tolerance, and frequency requirements are analyzed by relating the tasks to the expected service loads. A time line analysis is performed and the data are compiled into a detailed man/machine function list illustrated in Fig. 3-2.

3.9 INFORMATION FLOW ANALYSIS

Information flow analysis is an extension of system functional analysis and task analysis. The objective of information flow analysis is to validate the proposed operational management structure, to verify compatibility between the operating positions and between the operating positions and the STC, and to provide design criteria for the communication subsystem. The information flow analysis may also reveal the need for additional status displays and controls. The information flow analysis covers data content, duration, distribution, and frequency of voice and equipment communications. Information flow analysis charts are illustrated in Figs. 3-3 and 3-4.

3.10 SPECIFICATION OF SUBSYSTEMS HUMAN ENGINEERING DESIGN

The final step in the analysis and design phase is the definition of human engineering design requirements for each subsystem and their submission for inclusion in the subsystem performance specifications. A human engineering subsystem design data package is submitted to the Subsystem Engineering Department for review and concurrence. The data package consists of descriptions of operating positions, man/machine function lists, task analysis data, and information flow analysis data. The data are reviewed and necessary trade-offs are made with subsystem engineers. The finalized man/machine function lists and design sketches of the operating positions are submitted for inclusion in the subsystem performance specifications.

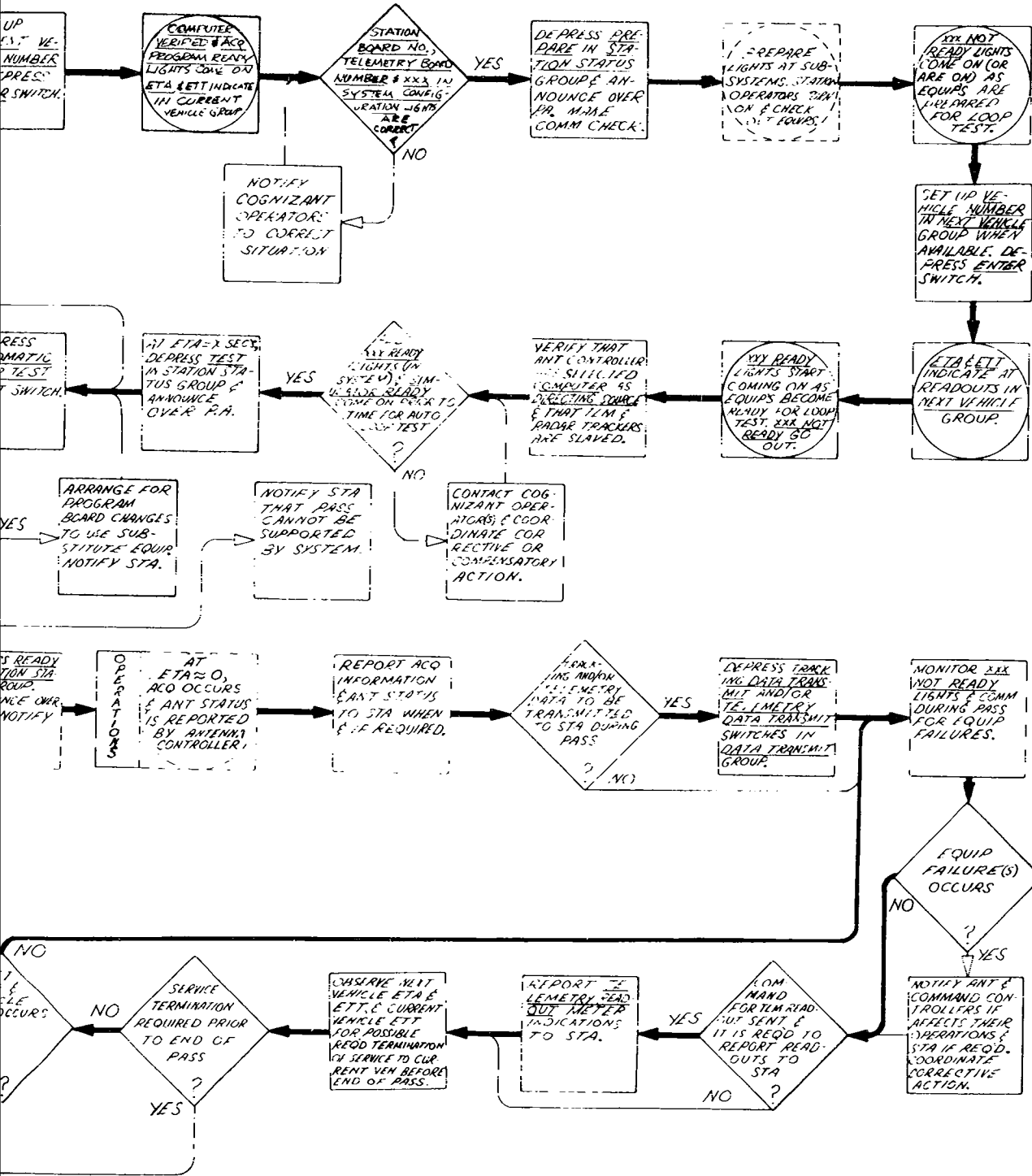

2

PRELIMINARY

NOTE: AUTOMATIC ACTION

SHIFT SUPERVISOR OPERATION SYSTEM OPERATORS CONSOLE, AUGMENTATION PROGRAM HUMAN FACTORS ENGINEERING SECTION (684-2), 711R71 HUMAN FACTORS & OPERATIONS ANALYSIS DEPT, PHILCO WDL REV. 11-5-62 KAS

Fig. 3-1 Decision/Action Flow Diagram

SUBSYSTEM	FUNCTION NUMBER	FUNCTION	TIME	ACCURACY	REMARKS
Radar	4	Space Research	ETA = 0 Reacquisition	Search Pattern Must be Selected as Follows: E ₁ Angle 2° Incr. A ₁ Angle 5° Incr. A ₂ Velocity 0-10°/sec	Antenna may be manually slewed to EPA

Fig. 3-2 Man/Machine Function List

PREPASS COMMUNICATIONS LOAD

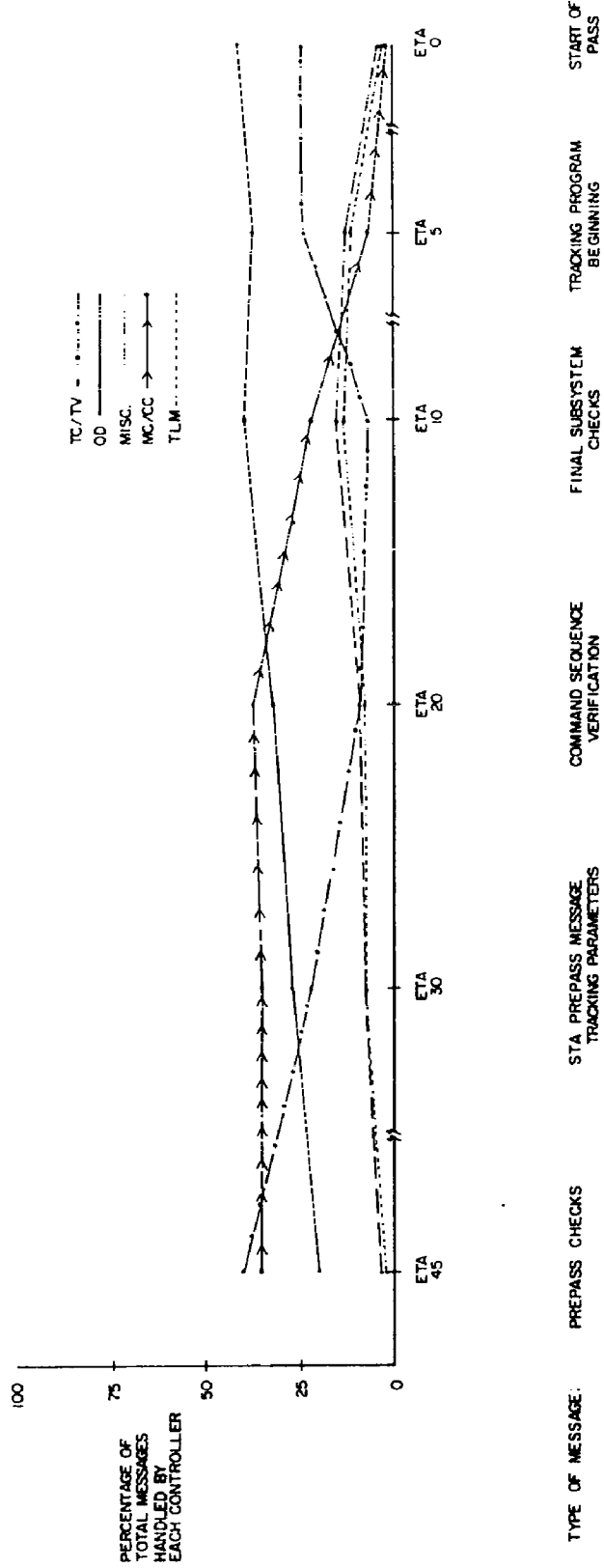

Fig. 3-3 Information Flow Analysis

COMMUNICATION LOAD
INITIAL PASS PHASE

TC/TV - - - -
 OD - - - -
 MISC. - - - -
 MC/ACC - - - -
 TLM - - - -

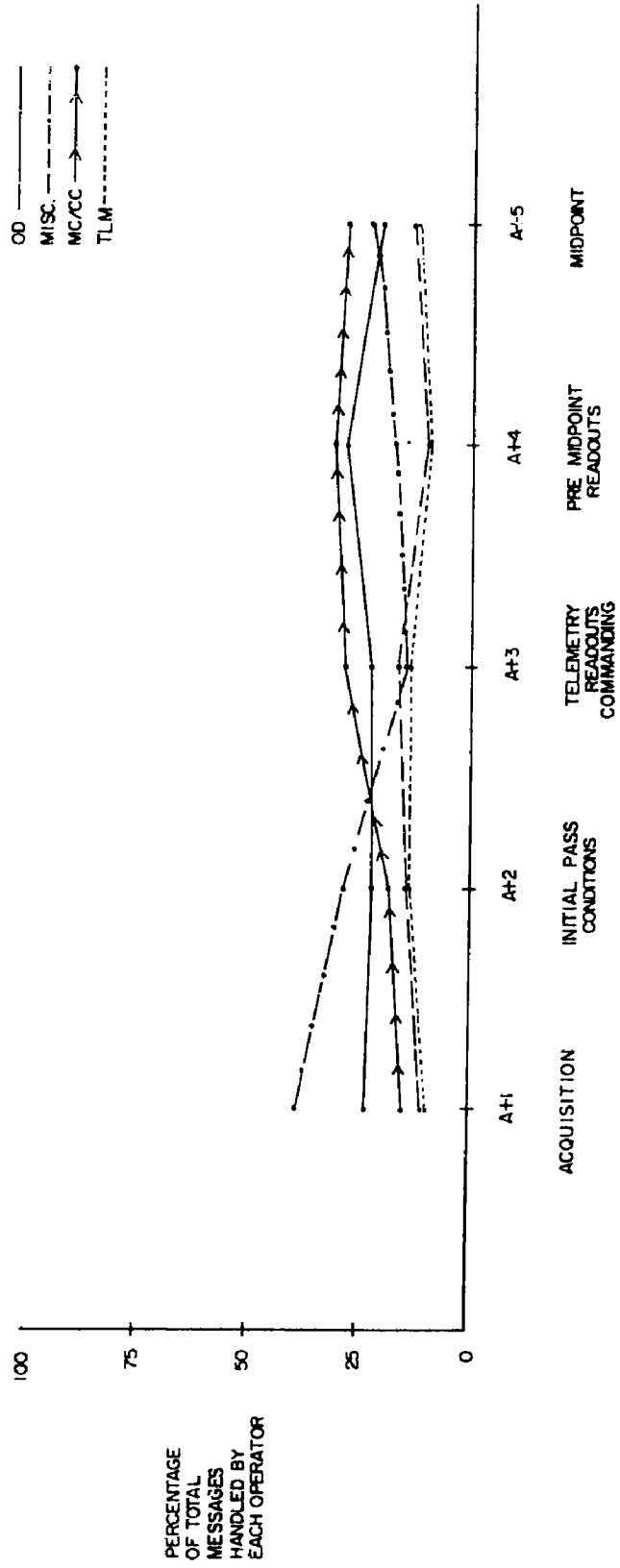

Fig. 3-4 Information Flow Analysis

3.11 PARTICIPATION IN MSAP PHASE A SYSTEM ANALYSIS AND DESIGN

Due to the late requirement for compliance with Exhibit 62-44A, formal human engineering participation in system analysis and design was limited to task analysis and information flow analysis of selected subsystems. The overall system information flow will be analyzed to provide design verification criteria, but corrective action, if required, must be accomplished by means of modifications performed on site.

SECTION 4 HUMAN ENGINEERING EQUIPMENT DESIGN

4.1 GENERAL DESCRIPTION

Human engineering equipment design converts system analysis data and subsystem specifications into detail control/display, communications and facilities design in accordance with MIL-STD-803. The design activity starts after the initial man/machine allocation is made and continues throughout the equipment development cycle.

The human engineering design phase comprises several tasks which are closely related and may be performed simultaneously. These tasks include: (1) listing of equipment for detail design, (2) design of control/display equipment, (3) development of mock-ups, (4) experiments utilizing dynamic simulation, (5) specification of human engineering design for equipment procurement, (6) functional design of communications equipment, and (7) specification of facilities design. These tasks are described in Paragraphs 4.2 through 4.8.

The design phase is concerned with the selection and specification of control/display components, layout and arrangement of components and equipment, configuration of communication nets, and specification of work environment. The key design parameters are accuracy, time, frequency, efficiency, maintainability, reliability, and safety. The limits of these parameters are defined in the system analysis documentation and subsystem performance specifications. These limits may be modified or specified more accurately during the equipment design phase.

4.2 LISTING OF EQUIPMENT FOR DETAIL DESIGN

The first step in equipment design is to identify the end items of equipment for human engineering design. The identification is made after the operating positions are defined and the decisions are made as to off-the-shelf procurement versus new development. The list is submitted through the MSAP Office to AF/SSD in accordance with Exhibit 62-44A.

4.3 DESIGN OF CONTROL/DISPLAY EQUIPMENT

The design of control/display equipment involves component selection, panel layout, panel location, and console configuration. The primary considerations in the design are man's perceptual capabilities and anthropometric characteristics. Control and display components are selected on the basis of required accuracy, time, and frequency of information inputs and operator responses as specified in the man/machine function lists. Panels are designed and located on the basis of sequence, logic and utilization data as shown on decision action flow diagrams and man/machine function lists. Static mock-up and dynamic simulation may be required to select an optimum design or to validate the design of control/display equipment.

The end product of a control/display design is a package of data consisting of a recommended control/display equipment configuration and location, and rationale for the recommended design including available experimental data. The design is reviewed and trade-offs are made with the Subsystem Engineering Department. Upon selection of a design approach, the data are revised and submitted for inclusion in the procurement specification and facilities design criteria.

4.4 DEVELOPMENT OF STATIC MOCK-UPS

Full scale static mock-ups of control/display consoles may be used to validate the console configuration and arrangement. Primary considerations are the accessibility of controls and the readability of displays, particularly displays shared by more than one operator. Mock-ups are constructed of cardboard or other equally inexpensive self-supporting material, and are updated to reflect design changes.

4.5 EXPERIMENTS UTILIZING DYNAMIC SIMULATION

Experiments utilizing manned simulation are included as part of detailed equipment design when analytical techniques fail to resolve a design problem and when experimental data are not available from other sources. The experiments may be used for evaluation of

competitive designs of complete operating positions or parts thereof. Statistically treated error, response time, and communications data are used as the basis for comparing various design approaches. The experimental data may result in a modification of system information flow, control/display design, and/or communications design.

4.6 SPECIFICATION OF HUMAN ENGINEERING DESIGN FOR EQUIPMENT PROCUREMENT

Equipment procurement specifications include requirements for control/display design as developed by human engineering and subsystem engineering. Human engineering inputs to the specifications are provided in the form of a control/display component list and layout drawings of control/display panels (see Figs. 4-1 and 4-2). Human engineering signature approval of specifications assures that the inputs are included.

4.7 FUNCTIONAL DESIGN OF COMMUNICATIONS EQUIPMENT

The functional design of communications equipment establishes the configuration of intra-station communication nets and the location and type of communication panels required at each operating position. Task analysis and information flow analysis provide the criteria for communications design. The human engineering communications design documentation includes a net configuration chart, illustrated in Fig 4-3. The location of communications equipment is specified on a facility layout drawing, illustrated in Fig. 4-4.

4.8 SPECIFICATION OF FACILITIES DESIGN

Human engineering and subsystem engineering determine work space requirements, location of control/display and communication equipment, and acceptable environmental conditions for facilities design. A preliminary equipment layout drawing (see Fig. 4-4) is prepared and submitted with other human engineering design data for subsystem engineering review and concurrence. The Subsystem Engineering Department submits the data for inclusion in the facilities design criteria. Human engineering signature approval of the equipment layout drawings assures that the facilities design meets human engineering requirements.

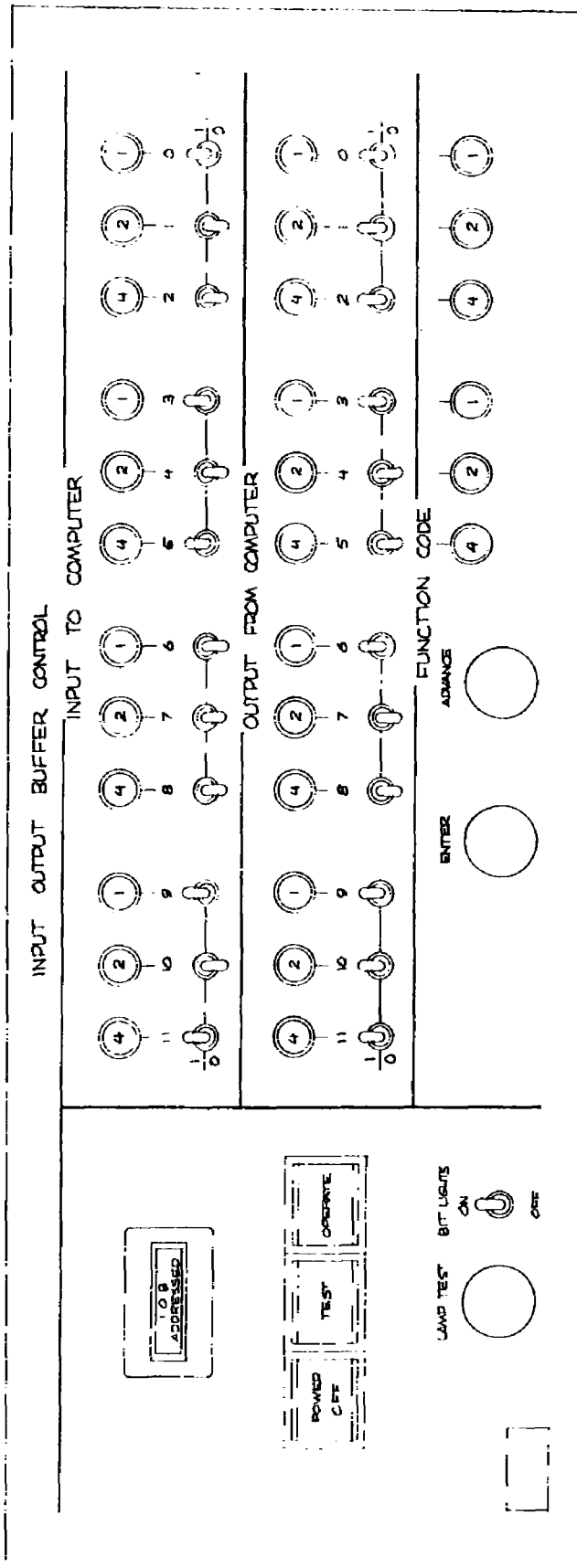

Input/Output Buffer Panel
Man/Machine Design Section

Fig. 4-1 Panel Layout Drawing

NOMENCLATURE	HARDWARE	vendor code*	FUNCTION	SIGNAL SOURCE
I.O.B. Addressed	Legend light, white	1d	Indicates I.O.B. has been selected by the computer.	I.O.B. Logic
Power Off	Switch, pushbutton, momentary, illuminated legend, white	1a	Selects power off for the I.O.B.	N.A.
Test	Switch, pushbutton, solenoid held, interlocked, illuminated legend, white	1a	Selects test mode of operation and enables I.O.B. test function. Interlocked with "Operate" switch. Applies equipment power.	N.A.
Operate	Switch, pushbutton solenoid held, interlocked, illuminated legend, white	1a	Selects operate mode and applies equipment power.	N.A.
Lamp Test	Switch, pushbutton momentary	2a	Tests lamps of switch legends and indicator lights.	N.A.
Bit Lights On/Off	Switch, toggle, 2 position		Selects power on or off to the bit lights.	N.A.
<u>Input to Computer Group</u> #11, 10; 9, 8, 7, 6, 5, 4, 3, 2, 1 & 0	Pilot lights, numbered, white	4a	Displays in octal code, binary input to the computer from different subsystems.	I.O.B. input registers
PANEL NAME				page 1 of 3

*see last page for vendor code
 WDL 1122R (8-26)
 INPUT OUTPUT BUFFER CONTROL PANEL - MSAP
 Fig. 4-2 Control/Display Component List

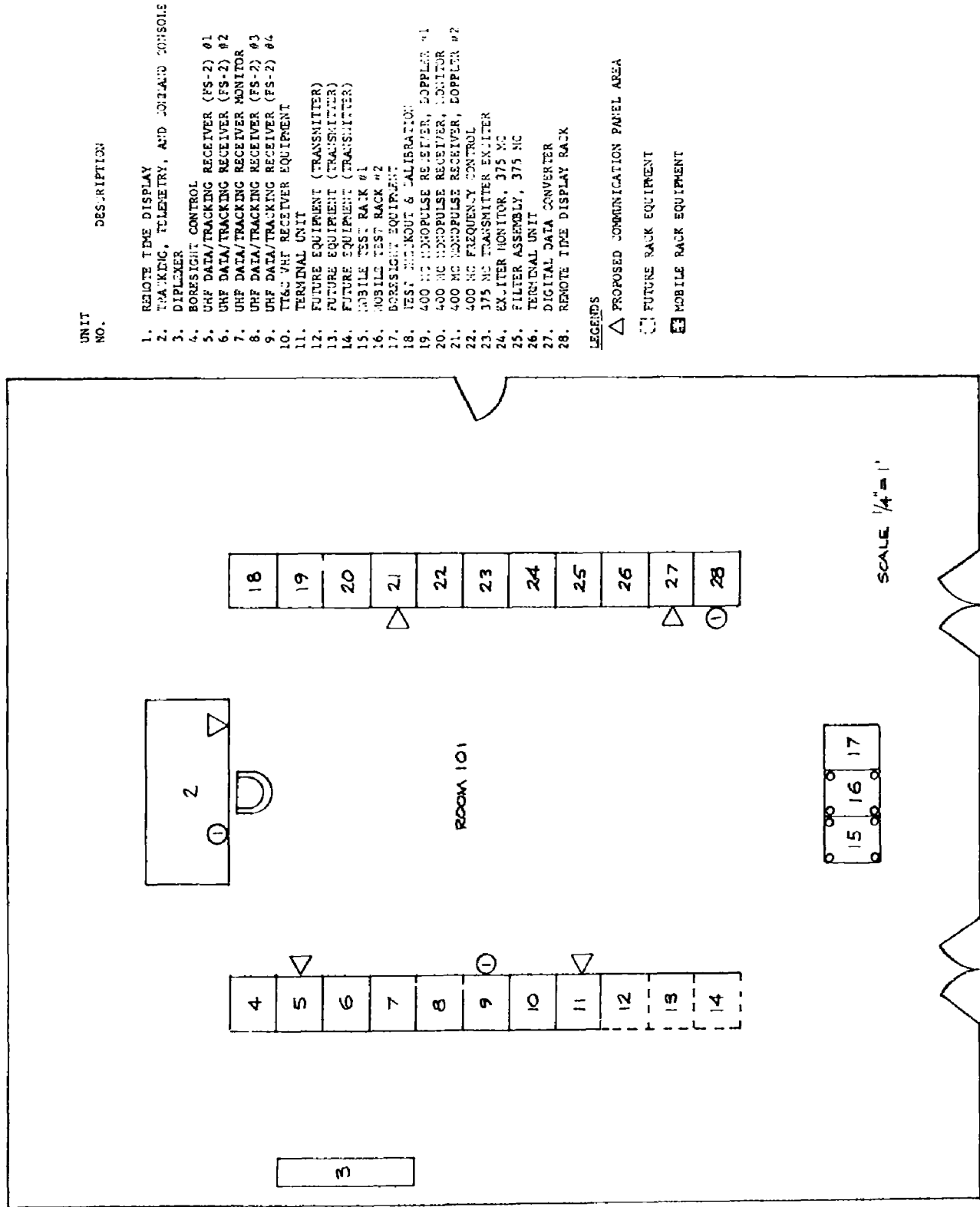

- | UNIT NO. | DESCRIPTION |
|----------|--|
| 1. | REMOTE TIME DISPLAY |
| 2. | TRACKING, TELEMETRY, AND JOINT-AID CONSOLE |
| 3. | DIPLEXER |
| 4. | BORESIGHT CONTROL |
| 5. | UHF DATA/TRACKING RECEIVER (FS-2) #1 |
| 6. | UHF DATA/TRACKING RECEIVER (FS-2) #2 |
| 7. | UHF DATA/TRACKING RECEIVER (FS-2) #3 |
| 8. | UHF DATA/TRACKING RECEIVER (FS-2) #4 |
| 9. | UHF DATA/TRACKING RECEIVER (FS-2) #4 |
| 10. | UHF VHF RECEIVER EQUIPMENT |
| 11. | TERMINAL UNIT |
| 12. | FUTURE EQUIPMENT (TRANSMITTER) |
| 13. | FUTURE EQUIPMENT (TRANSMITTER) |
| 14. | FUTURE EQUIPMENT (TRANSMITTER) |
| 15. | MOBILE TEST RACK #1 |
| 16. | MOBILE TEST RACK #2 |
| 17. | BORESIGHT EQUIPMENT |
| 18. | TEST CHECKOUT & CALIBRATION |
| 19. | 400 MC DOPPLER RECEIVER, DOPPLER #1 |
| 20. | 400 MC DOPPLER RECEIVER, MONITOR |
| 21. | 400 MC DOPPLER RECEIVER, DOPPLER #2 |
| 22. | 400 MC FREQUENCY CONTROL |
| 23. | 375 MC TRANSMITTER EXCITER |
| 24. | EXCITER MONITOR, 375 MC |
| 25. | FILTER ASSEMBLY, 375 MC |
| 26. | TERMINAL UNIT |
| 27. | DIGITAL DATA CONVERTER |
| 28. | REMOTE TIME DISPLAY RACK |

- LEGENDS**
- △ PROPOSED COMMUNICATION PANEL AREA
 - FUTURE RACK EQUIPMENT
 - ▣ MOBILE RACK EQUIPMENT

Fig. 4-4 Facility Layout Drawing

4.9 MSAP PHASE A HUMAN ENGINEERING EQUIPMENT DESIGN

During MSAP Phase A, human engineering equipment design complies with Exhibit 62-44A on the following subsystems:

- a. Control/Display
- b. Data Handling
- c. Checkout
- d. Intra-Station Communications

These subsystems represent the major portion of newly developed equipment for MSAP Phase A. MIL-STD-803 is used as a guidance document for human engineering of other equipment.

SECTION 5

HUMAN ENGINEERING DESIGN ASSURANCE

5.1 GENERAL DESCRIPTION

Human engineering design assurance provides guidance to equipment designers and a continuous review of specifications and drawings to insure proper application of human engineering criteria from initial design to final equipment acceptance. WDL-TR1968, "Human Engineering Design Check List," 1 February 1963, is distributed to equipment designers for use as a design guide. Specifications and drawings for equipment requiring human engineering design are reviewed and signed-off by a human engineering representative. The design assurance activity comprises six formal review and sign-off actions:

1. Subsystem performance specification review and sign-off
2. Procurement specification review and sign-off
3. Rack evaluation and panel top assembly drawing review and sign-off
4. Facility equipment layout drawing review and sign-off
5. Program office change order review
6. Acceptance test specification review

5.2 DESIGN ASSURANCE PROCEDURE

The design assurance and sign-off procedure is illustrated in Figs. 5-1 and 5-2. The specification review procedure involves a review of the preliminary specification, submission of recommended changes to the specification project engineer, review of changes with the cognizant engineer and specification sign-off. If a conflict arises between the human engineering requirements and the equipment

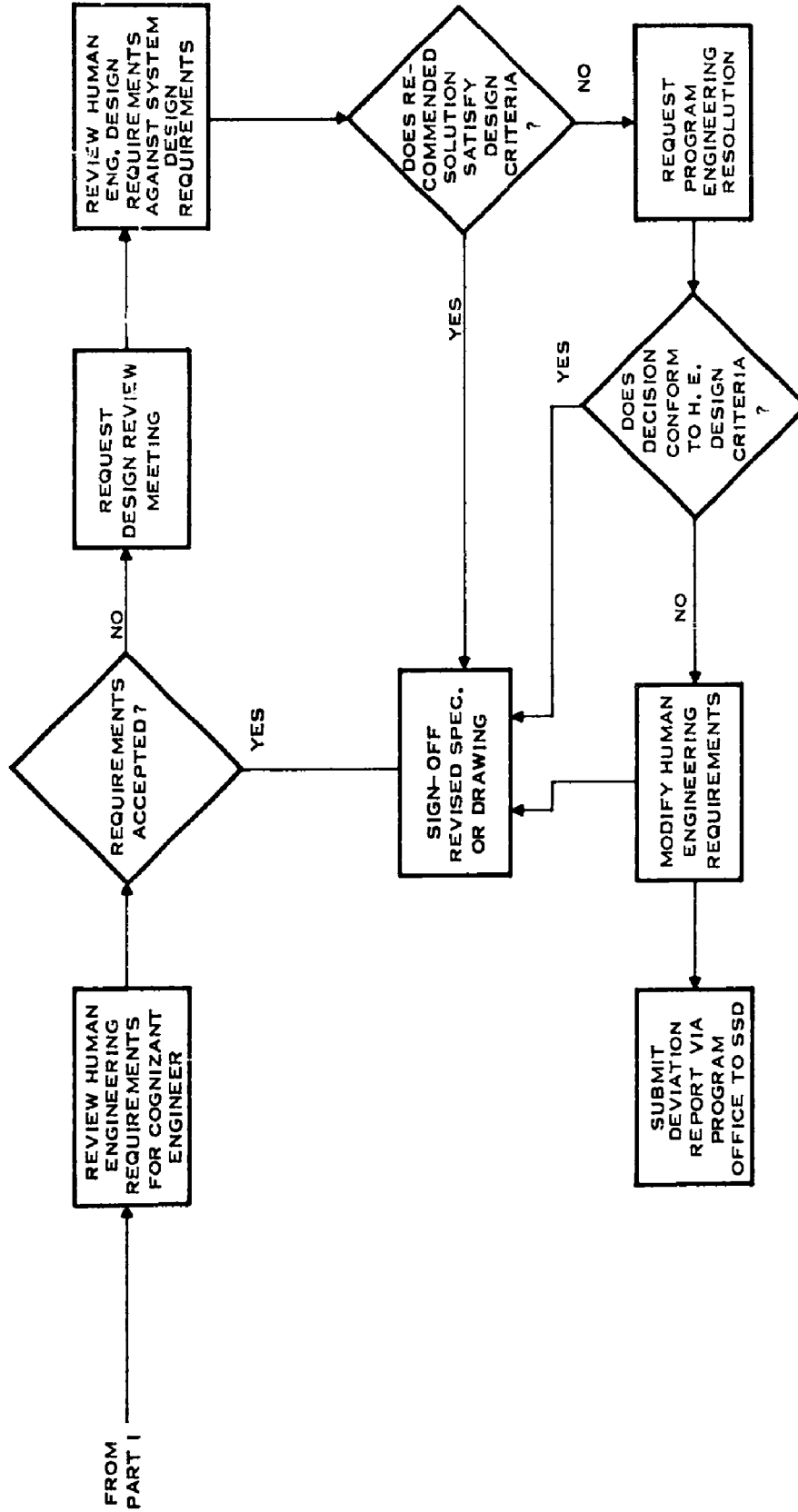

Fig. 5-2 Human Engineering Design Assurance Procedure (Part II)

design requirements, it is resolved through design review action with progressively higher levels of technical management through program engineering level. If the decision is that human engineering requirements must be compromised due to overriding equipment design or program considerations, the human engineering requirements are modified accordingly and the specification is signed off. A deviation report is prepared in accordance with Exhibit 62-44A and submitted through the program office to AF/SSD.

5.3 DESIGN REVIEW REQUIREMENTS

Design review requirements for each review action are described below:

1. Subsystem Performance Specifications
Man/machine function descriptions and control/display layout drawings are reviewed to assure compliance with the previously established human engineering design for the subsystem.
2. Procurement Specifications
Control/display component descriptions and detailed panel layout drawings are reviewed to assure compliance with the established human engineering design for the equipment.
3. Rack Elevation and Panel Top Assembly Drawings
Panel locations, mechanical design, and part lists are reviewed to assure that the final design is acceptable prior to release to fabrication.
4. Facility Equipment Layout Drawings
The location of operating positions, time and status displays, and communications equipment, and the availability of work space are reviewed to assure that the facilities design complies with human engineering facilities criteria prior to equipment installation.

5. Program Office Change Orders

Change orders are reviewed for changes affecting human engineering design.

6. Acceptance Test Specifications

Test requirements affecting man/machine functions are reviewed to assure that the functional verification of control/display operation is in accordance with the previously established human engineering design.

Continuous liaison is maintained with the subsystem engineers and the equipment designers. This assures that the human engineering requirements are properly integrated during the design and that minimum changes are required in specifications and drawings.

SECTION 6

HUMAN ENGINEERING ACCEPTANCE TEST AND DESIGN VERIFICATION

6.1 GENERAL DESCRIPTION

Human engineering design is verified during acceptance testing and during Phases III and IV of Installation and Checkout at TTS. The human engineering acceptance test is performed on the first deliverable article of equipment. The acceptance test is conducted in-plant during equipment acceptance testing and is completed at the test site, if required. The acceptance test comprises two parts: a visual inspection in accordance with a check list, WDL-TR1968, based on MIL-STD-803 and a control/display function test as specified in the equipment acceptance test specification.

Design verification is conducted at TTS concurrently with the subsystems and system checkout. This verification comprises five parts:

1. Completion of checks required to verify compliance with MIL-STD-803 on equipment acceptance tested in-plant.
2. Inspection and test of all control/display equipment not previously tested, in accordance with the acceptance test check list.
3. Monitoring of subsystems functional tests.
4. Monitoring of system functional tests during fly-bys and during system checkout with the checkout subsystem.
5. Analysis, evaluation, and documentation of the verification results.

The acceptance test and the design verification procedures are outlined in the following paragraphs. A detailed design verification plan is being prepared in accordance with Exhibit 62-44A. This plan will be submitted through the MSAP Office to AFSSD for approval.

6.2 ACCEPTANCE TEST PROCEDURE

The human engineering acceptance test is performed with the assistance of the Test Operations Section of WDL Product Assurance Organization. Human engineering provides test operations with the acceptance test check list, answer sheets, and a list of the equipment to be acceptance tested. The Test Operations Section provides the test schedules and the personnel for operating equipment during the acceptance test. The acceptance test answer sheets are completed and signed by a test operations representative and a human engineering representative. The completed answer sheets form a part of the acceptance test report. If the equipment does not meet the acceptance test requirements, action is initiated, as illustrated in Fig 6-1, to resolve the problem.

1. Visual Inspection

The visual inspection is concerned with the mechanical operation, location, arrangement, form, readability, and coding of controls and displays. Power is applied to the equipment to check control interlocks and multi-color displays.

2. Function Test

During the functional test, human engineering is concerned with the functions and the interaction of controls and displays. Equipment acceptance test specifications are used as the reference for monitoring this portion of the test. The test includes monitoring of equipment activation, checkout, normal operation, manual override operation, and shutdown. Particular attention is given to the operations sequence and information feedback. The functional test is

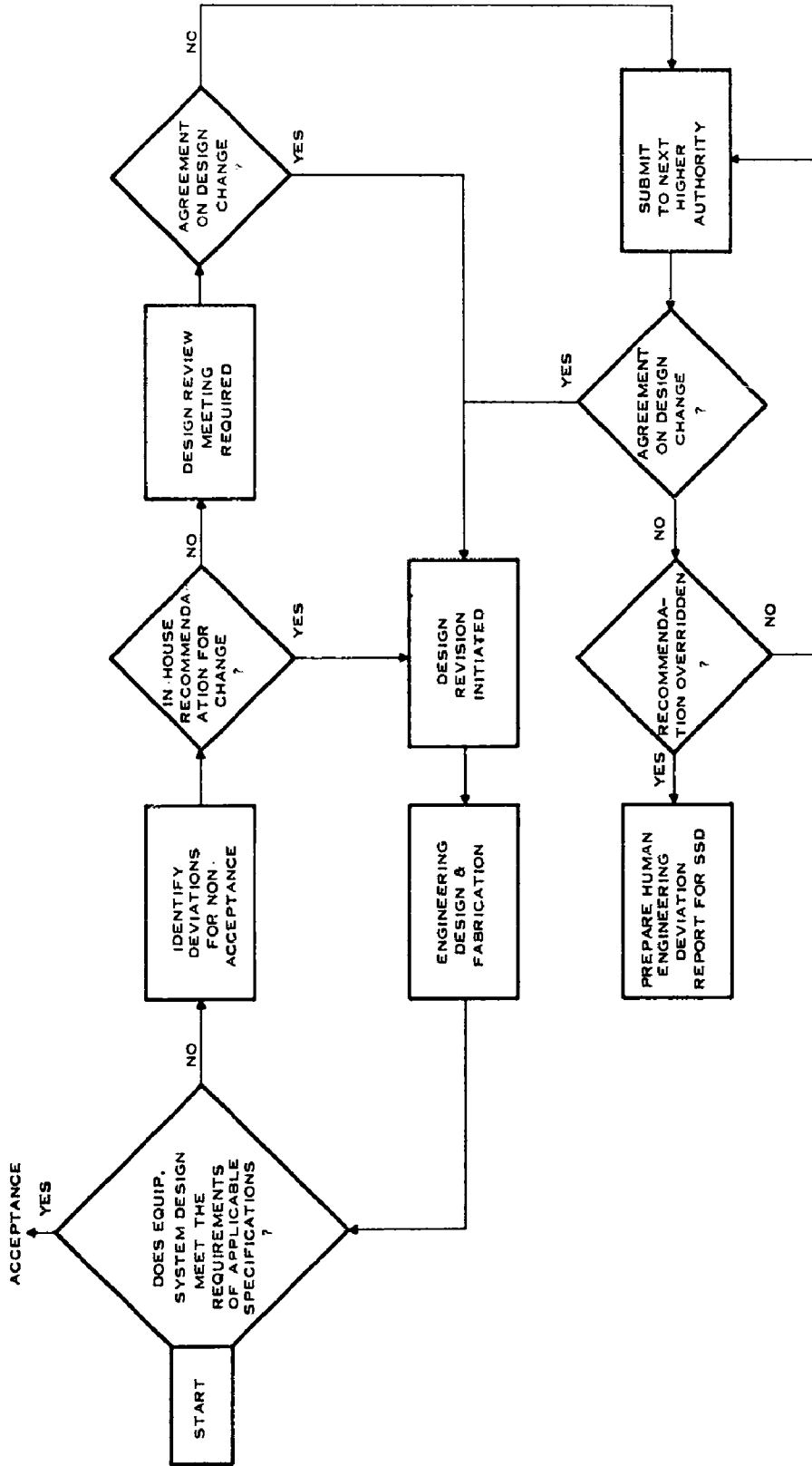

DWG 812716

Fig. 6-1 Procedure for Deviation From Human Engineering Criteria

performed to the extent possible with the capabilities of the equipment acceptance test setup.

3. Work Space/Environment

Noise sound, temperature, humidity, and illumination levels, work space adequacy, and safety compliance are measured and/or verified at the test site.

6.3 DESIGN VERIFICATION

Design verification is conducted with assistance from the Station Integration Office, Field Activation Department, and the site operations and maintenance personnel, if required. Human engineering prepares a design verification plan. This plan is reviewed and approved by the MSAP Office and coordinated with the Station Integration Office. The station Integration Office prepares checkout schedules and provides the personnel for equipment checkout and operation. Man/Machine Design Section personnel with the assistance of Field Activation Department personnel are responsible for monitoring and recording man/machine performance at subsystem and system levels. The verification results depend largely on conclusions formed by the analyzing personnel and are affected by the progress of the equipment checkout (the time available for monitoring of trouble free operation). Although most of the tests are conducted on the I&C procedures, it is expected that at the system level there will be correspondence between the I&C procedures and the operation procedures. The task time and frequency, however, may vary considerably from an operational situation. It is expected that the station operational procedures are also available on-site for verification during Phase IV. The human engineering design verification will be continued throughout the operational procedures verification.

The step-by-step procedures are used as check lists for verifying the human engineering functional design. Voice communications are recorded during the tests to provide complete data on the information flow. Verification data are analyzed to determine the requirements

for modification of procedures or control/display instrumentation. The verification results and the recommended modifications are published in a design verification report.

1. Design Verification Plan

The design verification plan contains a list of equipment to be verified and the visual, environmental, and functional verification requirements for each item of equipment and facilities. The plan also contains human engineering check list data which are used in conjunction with the procedures as a part of the functional verification criteria. Parts of acceptance test check lists, I&C procedures, and operational procedures are identified as a part of the human engineering design verification criteria. Specific criteria are identified for each phase of operation: equipment activation, checkout, normal operation, manual override operation, and shutdown.

The plan outlines, in general, the procedures for monitoring, recording, analyzing test data, and evaluating the design.

2. MUSAP Phase A Functional Design Verification

The objective of the MSAP Phase A functional design verification is to verify the design of control/ display and communication equipment at the system level and to make recommendations, as deemed necessary, for modifications to be implemented during follow-on phases of MSAP.

The functional design verification consists of monitoring I&C operations; gathering, analyzing, and evaluating data; and formulating recommendations for design improvement. The operations monitoring consists of observing and recording the step-by-step man/machine operation at selected operating positions.

The I&C checkout data sheets will provide a documentary certification for approval or disapproval of the test results. Upon completion of all documented tests the master vellum form data sheets shall be witnessed by authorized representatives and forwarded to the Philco WDL Station Integration Office for release approval. The monitoring notes, communication records, and I&C checkout lists are analyzed to identify errors, response time lags, interruptions in information flow, and excessive task loads. Since only in very few instances are limits of these parameters specified, decision as to when and where the man/machine performance is degraded is based largely on the judgment of the data analyst. The data must be evaluated by Human Factors Engineering Department personnel to determine if indentifiable performance degradation can be corrected through modification of procedures or modification of control/display and/or communications design. The recommendations are documented in the design verification report.

Although the functional design verification is affected by the progress of equipment checkout, it is necessary to reach a reasonable level of confidence in the verification data. Human Factors Engineering Department personnel will analyze the initial verification data to determine where additional observations may be required to gain additional confidence in verification results.

SECTION 7
HUMAN ENGINEERING
STUDIES

7.1 STUDY REQUIREMENTS

The MSAP Phase A Human Engineering Program has revealed the need for development of analytic techniques and experiments to provide design data and to support human engineering at system and subsystem levels. The study requirements are primarily due to the following reasons:

1. System and subsystem design criteria do not specify the system operational requirements in adequate detail.
2. Human engineering design cannot be quantitatively compared with the system availability goal and maintainability and reliability design goals.

The proposed studies are outlined in the following paragraphs. The studies should be funded on an SCF basis and will be included in the human engineering portion of the Philco WDL response to the "Research and Development Work Statement for Satellite Control Follow-on Contract".

7.2 DEFINITION OF OPERATIONAL REQUIREMENTS AND HUMAN ENGINEERING CRITERIA FOR MSAP FOLLOW-ON PHASES

This study would comprise two phases of activity through CY 1963. The first phase of activity would provide design criteria for MSAP Phase B human engineering efforts in support of modification of existing VHF systems and their integration with the new VHF systems supplied under MSAP Phase A. MSAP Phase B effort is defined in "Exhibit B to Letter Contract Designated Supplemental Agreement No. 18 to Contract AF04(695)-113-Work Statement Multiple Satellite Augmentation Phase "B".

The second phase would provide design criteria for simplification of the UHF Systems at VTS and NHS. Some preliminary work performed

under Program 461 funding for human engineering evaluation of VIS and NHS will be applicable to this phase. On-site modifications were documented and station communications and control/display capabilities were evaluated. Some general design recommendations will be in the evaluation reports to be published in early January 1963. The second phase would define operational requirements for all programs to be supported by the UHF system and convert these requirements to human engineering design criteria. Examples of the problems to be investigated during study are given below:

1. Definition of System Operating Load. In the past, operational requirements have been frequently analyzed to determine station operating loads and their distributions for various multiple satellite operations. A service load model has not been selected as a criterion for system design. A model would provide the basis for specifying availability goals, turn-around times, and support requirements. These in turn have significant impact on human engineering design, maintainability, reliability, manning, and procedures.
2. Allocation of Subsystems to Systems. In the support of any given flight, the allocation of station subsystems to make up the operational system must be made on the basis of flight operations priority and the subsystems' readiness. The allocation problem is straightforward in a simple system, but it becomes more complex when two systems are assembled from a common equipment pool and when the operations are overlapping or closely spaced. Then up-to-the-minute knowledge of maintenance status and operational schedules and priorities is necessary to resolve conflicting equipment demands. The solution to this problem is closely related to several operational design factors including the assignment of operational and maintenance functions, STC-site information flow, intra-site information flow, and the operational management structure.

3. Assignment of Maintenance and Operational Responsibilities. In view of the subsystem allocation problem, it may be desirable to divorce the operational and on-line maintenance tasks (check-out, etc.) at some level within the operational management structure. One approach would be to provide only operational control from the SOC's and to direct on-line maintenance and subsystem allocation from a new supervisory control position. The system management structure, information flow, and tasks should be analyzed to establish the need for this position and to specify the design of associated control/display equipment.

4. Establishment of Operational Management Structure. The present operations management is based on the concept of a single system supporting one satellite at any given time. In the future it will be impossible to conduct the presently time-consuming rehearsals and tests prior to a flight. Until the satellites become standardized, operational personnel must assimilate and execute several different sets of procedures in a short time span. To alleviate this problem, the operational management structure of the system should be reviewed to assure that the procedures and information flow can be optimized. Some of the questions that need to be answered include the following:
 - a. Is there a requirement to keep the operating crews intact?
 - b. What are the operational information requirements at the various levels within the management structure?
 - c. What are the effects on the information flow if the crews remain intact? If not?

5. Information Flow Analysis. As noted in the foregoing discussion, detailed intra-station information flow is a function of the operational management concept, allocation of system functions, and the system configuration. Analysis of the information

flow is necessary to define the control/display, the checkout, and the communication subsystems design. The analysis should at least answer the following specific questions:

- a. Is STA-site information flow compatible with the on-site operation?
- b. Can prepass data be effectively distributed to on-site personnel and to computers?
- c. What are the effects on the information flow due to contingencies such as communication problems and equipment failures?

7.3 PREDICTION AND MEASUREMENT OF HUMAN ENGINEERING DESIGN PERFORMANCE

This study would investigate the feasibility of specifying quantitative human engineering design criteria and measurement of human engineering design performance for the purpose of design verification at system and subsystem levels. Should this study produce positive results, several major achievements would be realized. Quantitative design criteria would enable comparison of human engineering design goals on a common scale with maintainability and reliability design goals and thereby permit optimization of these design factors in meeting the system performance requirements. Functional human engineering design verification could be quantitative rather than qualitative and the man/machine performance could be measured rather than evaluated on the basis of personnel judgement. This study would comprise four phases of activity which are described below:

1. Phase I

Phase I will involve development of a mathematical paradigm, and the definitions of terms, methods, goals and applications. The final product of Phase I will be a detailed study plan to be submitted to AFSSD for approval. The report will detail:

- a. A definition of terms, goals, and applications,
- b. Derivation of the measurement formulas,
- c. The experimental design for Phases II and III,
- d. Design of simulation equipment,
- e. A schedule for the remainder of the study effort,
- f. A bibliography of related material,

2. Phase II

Phase II will be a series of experiments designed to prove or disprove the value of the measurement method. A manned simulator will be used as the experimental device. The experiment will be divided into test trials, each trial composed of a simulation of possible contingency situations on a set of control/display panels.

3. Phase III

This phase will entail the final validation of the measurement method by monitoring operational equipment. This will require:

- a. The computation of a predicted operability figure of an operational control/display system,
- b. The collecting of operational data to find the actual operability figure,
- c. The comparison of the predicted figure to the actual figure to check that the difference is statistically insignificant at a desired confidence level.

4. Phase IV

All data will be compiled, evaluated, and published for general use.

7.4 ESTABLISHMENT OF MAN/EQUIPMENT COMPONENT DESIGN STANDARDS

The purpose of this study is to establish human engineering design standards to be used in the design of all subsystems, equipment and components in the MSAP and follow-on program. In addition, these standards will provide a basis for design within the SCF.

1. Study Objective

The study objective is to establish human engineering standards for the selection and utilization of components and items of hardware for all system equipment, including voice communication equipment, to be operated and/or maintained by personnel while fulfilling the intended mission of the system. To achieve maximum benefit across programs within the SCF, it is recommended that the study be implemented as a continuous effort.

2. Need for MUSAP Design Standards

At the present time, the aerospace industry employs such techniques as failure/error feedback reporting followed by retrofit programs to make up for inadequacies in operability, maintainability, and reliability. These techniques have not been too effective except for lengthy production runs. With relatively short production runs and the limited number of units manufactured for R&D programs, back track corrections are very much unacceptable, particularly in terms of time and cost. The need for human engineering design standards for MSAP arises from requirements to meet SCF standardization objectives and to minimize the need for field modifications. Design standards must be upgraded and continually improved to keep abreast of component developments.

3. Study Outline

The major steps required to establish the design standards are as follows:

- a. Formulate a preliminary listing of all classes and types of components to be used in the system. Typical components to be listed are: Controls, displays, connectors, handles, access fasteners, etc.
- b. Establish criteria for the evaluation and selection of components to be employed in the system. This evaluation and selection criteria will be based on and will comply with MIL-STD-803.
- c. Establish a central file of catalogs and other literature provided by manufacturers of components that appear to meet the requirements of MIL-STD-803. Also to be included in this file is an up-to-date listing of components currently used in existing satellite control systems and a record of their acceptability.
- d. Establish a component standardization working group composed primarily of human engineering, maintainability, and reliability specialists. The function of this working group would be to:
 - (1) Establish component test, evaluation and selection criteria.
 - (2) Make determinations as to whether off-the-shelf components should be utilized in a given design.
- e. Conduct both static and dynamic tests of components tentatively selected for inclusion in equipment design and, as a result of these tests, make final selections of components to be used in equipment design. A typical human engineering component evaluation is described in WDL-TR1587, "A Human Engineering Evaluation of some Self-Illuminated Digital Displays", dated 31 July 1961.
- f. Prepare human engineering component design standards to be used by equipment design engineers. These design standards will also identify the preferred as well as alternate component manufacturers.

The establishment of design standards for MSAP does not minimize or alter the requirement for human engineering equipment design. Human engineering assistance will be required in implementing these design standards, working out optimal compromises when compromise is necessary, and for assisting design engineers in the solution of human engineering problems not covered in this study.

7.5 APPLICATION OF DYNAMIC SIMULATION IN STUDIES

Dymanic simulation is required to support the studies outlined in Paragraphs 7.2 and 7.3. The simulation must be flexible to be quickly adaptable to the various SCF systems configurations and to provide growth potential. It should provide the means for rapid reduction and analysis of test data. The design of the simulation equipment will be specified in the detailed study plan referenced under Paragaraph 7.3a. As presently conceived, the simulation equipment would be used for the following in the MSAP follow-on phases and in other SCF human engineering programs:

1. Experimental validation of techniques for prediction and measurement of human engineering design performance.
2. Experimental comparison of competitive control and display instrumentation designs.
3. Gathering of test data on control and display components.
4. Developmental testing of instrumentation and communication techniques in support of SCF development.

SECTION 8
HUMAN ENGINEERING
SCHEDULE

8.1 SCHEDULE REVIEW PROCEDURE

A formal PERT system has not been implemented for MSAP Phase A. A Work Order Schedule and Budgetary Control form is used for identification of the human engineering milestones and the start and completion dates of the various tasks. A weekly progress report is submitted to the MSAP Office and the milestone schedule is reviewed and updated as required to reflect the overall program schedule. The MSAP human engineering status is reported monthly to AF/SSD and a formal human engineering report is submitted quarterly to provide detailed status of the human engineering program in accordance with AF/SSD Exhibit 62-44A.

8.2 MILESTONE SCHEDULE

A human engineering milestone schedule is illustrated in Fig. 8-1. The schedule shows the major task completion milestone and other significant events in the MSAP Phase A Human Engineering Program. The program milestones are defined below:

1. Milestone 1. Human Engineering Plan Complete
The date of submission to the MSAP Office for review and approval.

2. Milestone 2. Task Analysis Complete
The end date of system analysis effort.

3. Milestone 3. Design Complete
The end date of human engineering design contribution to MSAP equipment design.

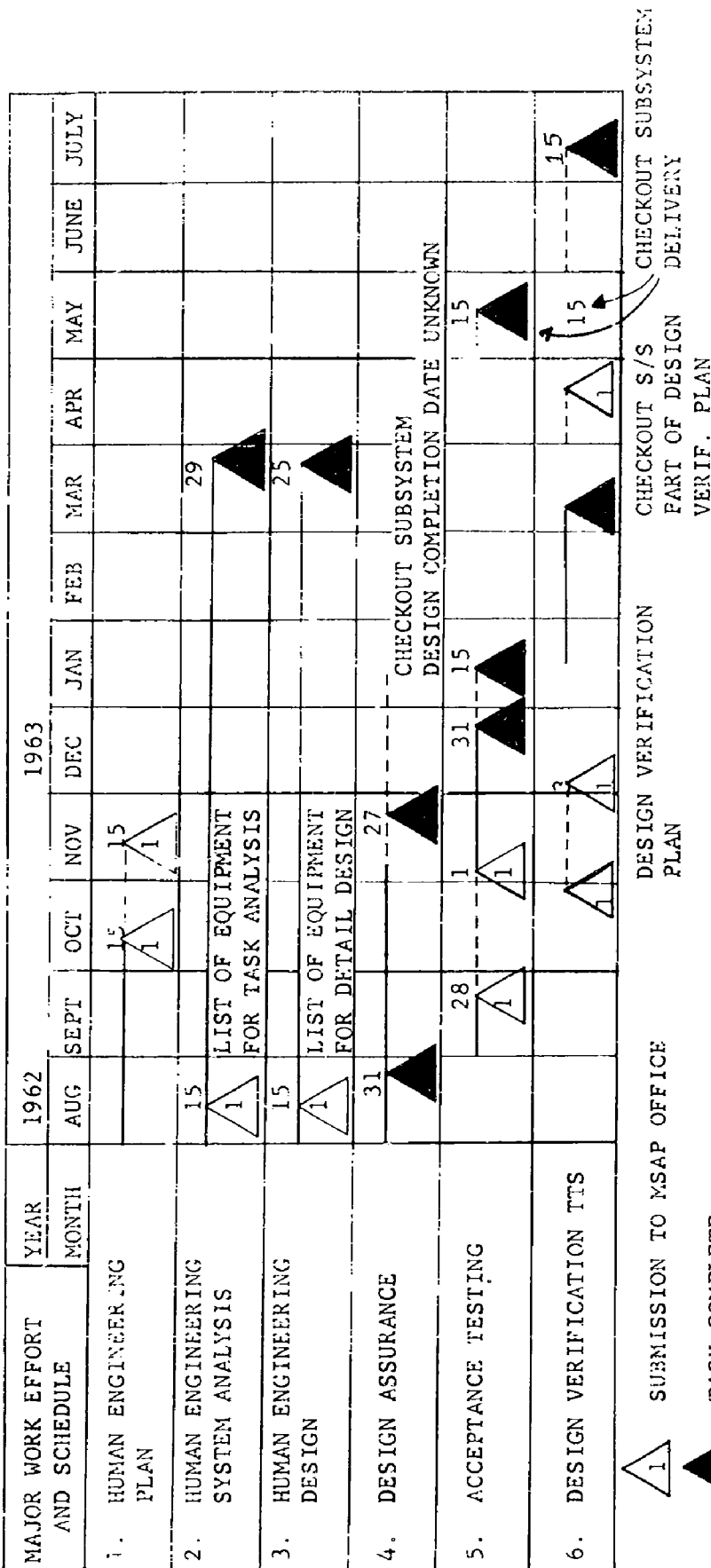

Fig. 8-1 Human Engineering Milestone Schedule

4. Milestone 4. Design Assurance Complete

The end date of design documentation review and sign-off by human engineering.

5. Milestone 5, Acceptance Test Complete

The completion date of in-plant human engineering acceptance tests and test documentation.

6. Milestone 6. Design Verification Complete

The completion date of the human engineering design verification report on design verification at the test site.

DISTRIBUTION LIST

<u>Address</u>	<u>No. of Copies</u>
Commander Space Systems Division Air Force Systems Command Air Force Unit Post Office Los Angeles 45, California Attn: Technical Data Center	10
Attn: Maj. K. J. Lindsay, SSOCO	5
ASTIA Arlington Hall Station Arlington 12, Virginia	10
Aerospace Corporation P. O. Box 95085 Los Angeles, California Attn: C. M. Beyer (ASCO)	3
Attn: Mr. R. G. Stephenson	3
USAF Contract Support Detachment No. 3 Philco Corporation Western Development Laboratories Palo Alto, California Attn: Mr. D. W. Cowart	1
Philco Corporation Western Development Laboratories Palo Alto, California	38 + 1 reproducible
	<hr/> 70 + 1 reproducible

UNCLASSIFIED

UNCLASSIFIED