

UNCLASSIFIED

AD 297 437

*Reproduced
by the*

**ARMED SERVICES TECHNICAL INFORMATION AGENCY
ARLINGTON HALL STATION
ARLINGTON 12, VIRGINIA**



UNCLASSIFIED

NOTICE: When government or other drawings, specifications or other data are used for any purpose other than in connection with a definitely related government procurement operation, the U. S. Government thereby incurs no responsibility, nor any obligation whatsoever; and the fact that the Government may have formulated, furnished, or in any way supplied the said drawings, specifications, or other data is not to be regarded by implication or otherwise as in any manner licensing the holder or any other person or corporation, or conveying any rights or permission to manufacture, use or sell any patented invention that may in any way be related thereto.

63-2-5

297 437

297 437

U. S. A R M Y
TRANSPORTATION RESEARCH COMMAND
FORT EUSTIS, VIRGINIA

CATALOGED BY ASTIA
AG AD No.

TCREC Technical Report 62-3A

FLEXIBLE-WING CARGO GLIDERS
VOLUME I

Task 9R38-01-017-72
Contract DA 44-177-TC-779

September 1962

PREPARED BY

RYAN AEROSPACE
A Division of The
RYAN AERONAUTICAL COMPANY
San Diego, California

ASTIA
RECEIVED
MAR 1 1963
RESOLVED
ASTIA



DISCLAIMER NOTICE

When Government drawings, specifications, or other data are used for any purpose other than in connection with a definitely related Government procurement operation, the United States Government thereby incurs no responsibility nor any obligation whatsoever; and the fact that the Government may have formulated, furnished, or in any way supplied the said drawings, specifications, or other data is not to be regarded by implication or otherwise as in any manner licensing the holder or any other person or corporation, or conveying any rights or permission, to manufacture, use, or sell any patented invention that may in any way be related thereto.

ASTIA AVAILABILITY NOTICE

Qualified requesters may obtain copies of this report from

Armed Services Technical Information Agency
Arlington Hall Station
Arlington 12, Virginia

This report has been released to the Office of Technical Services, U. S. Department of Commerce, Washington 25, D. C., for sale to the general public.

The information contained herein will not be used for advertising purposes.

The findings and recommendations contained in this report are those of the contractor and do not necessarily reflect the views of the U. S. Army Mobility Command, the U. S. Army Materiel Command, or the Department of the Army.

Contract DA 44-177-TC-779

**TCREC 62-3A
VOLUME I**

**FLEXIBLE WING CARGO GLIDERS
FINAL PROGRAM SUMMARY REPORT**

**Ryan Report No. 61B114(A)
15 September 1962**

**Prepared by
Ryan Aeronautical Company
San Diego, California**

**U. S. ARMY TRANSPORTATION RESEARCH COMMAND
FORT EUSTIS, VIRGINIA**

HEADQUARTERS
U. S. ARMY TRANSPORTATION RESEARCH COMMAND
TRANSPORTATION CORPS
Fort Eustis, Virginia

TCREC-ADS 9R38-01-017-72

SUBJECT: Flexible-Wing Cargo Glider

TO: See Distribution List

1. The work described in this report was accomplished by Ryan Aeronautical Company for the U. S. Army Transportation Research Command, Fort Eustis, Virginia, under the terms of contract DA 44-177-TC-779. The report covers an investigation of the use of the Flexible-Wing concept for aerial cargo delivery.

2. The conclusions made by the contractor are concurred in by this Command.

3. Based upon the facts presented in the report, proposals have been solicited and a contract will be awarded for a Flexible-Wing configuration of a 1,000-pound payload capability, which may be towed and/or dropped from existing Army aircraft. The program includes the detailed design, fabrication, and flight testing of the Flexible-Wing vehicle. The major objective of the program is to ascertain the feasibility of the Flexible-Wing concept and to provide information necessary for the development of an aerial cargo delivery system.

FOR THE COMMANDER:



CARL A. WIRTH
CWO-4 USA
Adjutant

APPROVED BY:

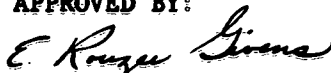

E. ROUZEE GIVENS
Project Engineer, USATRECOM

CONTENTS

	Page
I. Preface	v
II. List of Illustrations	vii
III. Summary	1
IV. Conclusions	5
V. Introduction	7
VI. Method of Approach	9
VII. Technical Discussion	13
Description of the 250 Pound Payload Glider	13
Description of the 1000 Pound Payload Glider	14
Description of the 4000 Pound Payload Glider	22
Description of the 8000 Pound Payload Glider	25
Air Drop Configurations	29
Design Criteria	33
Strength and Loads Considerations	35
Weight Analysis	36
Description of the Towing and Control System	38
Take Off and Landing Studies	48
Helicopter - Towed Glider Performance	48
Fixed Wing Aircraft - Towed Glider Performance	53
Glider Free Flight Performance	54
Stability and Control	54
Tow Aircraft Modification	65
VIII. Operational Utilization and Effectiveness	75
IX. Distribution	78

I. PREFACE

This is a Summary Report of a study program to determine the feasibility of the development of Flexible Wing Cargo Gliders.

This is Volume I of two volumes of the Final Report compiled for the U. S. Army Transportation Research Command under Contract No. DA 44-177-TC-779, dated 21 June 1961. Volume I is a summary of descriptions of the Flexible Wing Cargo Glider configurations design, design criteria, strength and loads, weight analysis, and a description of the towing and control systems. The characteristics of free-flight performance, towed performance, take-off and landing, and stability and control are also discussed. Operational utilization and effectiveness of the Flexible Wing Cargo Gliders, as applied to the operation of the U. S. Army, are briefly discussed.

Volume II presents a detailed analysis of design criteria and structural description, loads and stress analysis, weight and balance, and the towing and control systems; and gives a detailed analysis of all performance regimes and the stability and control of the configurations considered.

The study program resulted in the design of four basic configurations of Flexible Wing Cargo Gliders, having payload capabilities of 250, 1,000, 4,000 and 8,000 pounds each. Alternate versions of the 250, and 1,000 pound configurations were also developed to provide capability of air dropping the vehicle from the AC-1 (Caribou) aircraft for point delivery of logistical materiel.

Contents of the two volumes conform to subjects specified in the Statement of Work of the above referenced contract. Additional work has been included which may aid in expeditious evaluation of the feasibility of the Flexible Wing Cargo Glider concept.

II. LIST OF ILLUSTRATIONS

		Page
Table 1	Flexible Wing Cargo Glider General Data	3
Drawing 1	General Arrangement 250 Lb Payload Glider	15
Drawing 2	General Arrangement 1000 Lb Payload Glider	17
Drawing 3	General Arrangement 1000 Lb Payload Glider (Cable)	19
Drawing 4	General Arrangement 4000 Lb Payload Glider	23
Drawing 5	General Arrangement 8000 Lb Payload Glider	27
Drawing 6	Functional Arrangement of the Air Drop Config.	31
Table 2	Summary Weight Statement	37
Schematic 1	Electrical System 250 Lb Payload Glider	39
Schematic 2	Electrical System 1000 Lb Payload Glider	41
Schematic 3	Electrical System 4000 & 8000 Lb Payload Glider	43
Drawing 7	Hydraulic Control System 400 & 8000 Lb Payload Gliders	45
Figure 1	L-20A/Cargo Glider Take Off Distance	49
Figure 2	L-20A/Cargo Glider Take Off Distance	49
Figure 3	H-23D/Cargo Glider Take Off Distance	49
Figure 4	HU-1B/Cargo Glider Take Off Distance	49
Figure 5	H-34A/Cargo Glider Take Off Distance	49
Figure 6	Landing Distance vs Glider Design Payload	49
Figure 7	THP Required vs TAS 250 Lb Glider	51
Figure 8	THP Required vs TAS 1000 Lb Glider	51
Figure 9	THP Required vs TAS 4000 Lb Glider	51
Figure 10	THP Required vs TAS 8000 Lb Glider	51
Figure 11	Horizontal Range vs Altitude 250 Lb Glider	51
Figure 12	Horizontal Range vs Altitude 1000 Lb Glider	51
Figure 13	Horizontal Range vs Altitude 4000 Lb Glider	51
Figure 14	Horizontal Range vs Altitude 8000 Lb Glider	51
Figure 15	Rate of Climb vs TAS L-20A & Gliders	55
Figure 16	Rate of Climb vs TAS L-20A & Gliders	55
Figure 17	Rate of Climb vs TAS L-20A & Gliders	55
Figure 18	L-20A Mission Profile	55
Figure 19	L-20A Mission Profile	55
Figure 20	L-20A Mission Profile	55
Figure 21	L-20A Mission Profile	55
Figure 22	H-23D Maximum Rate of Climb	57
Figure 23	HU-1B Maximum Rate of Climb	57
Figure 24	H-34A Maximum Rate of Climb	57
Figure 25	H-23D Mission Profile	57
Figure 26	HU-1B Mission Profile	57

Figure 27	H-34A Mission Profile	57
Figure 28	H-23D Mission Profile	57
Figure 29	H-23D Mission Profile	57
Figure 30	Glider Trim Requirements	61
Figure 31	Longitudinal Geometry	61
Figure 32	Glider Neutral Trim Points	61
Figure 33	Center of Gravity Variation	61
Figure 34	Dynamic Stability During Tow Effects of Attach Points	63
Figure 35	Dynamic Stability During Tow Effect of Tow Line Length	63
Figure 36	Wing Sweep Back vs Wing Lateral Deflection	63
Figure 37	Dynamic Stability Variation With Directional Stability	63
Drawing 8	H-23D Modification for Towing	67
Drawing 9	L-20A Modification for Towing	69
Drawing 10	HU-1B Modification for Towing	71
Drawing 11	H-34A Modification for Towing	73

III. SUMMARY

Volume I of this Report summarizes the results of the technical findings of the study of the Flexible Wing Cargo Glider. Volume II describes the method of approach and feasibility in studying Design Criteria, Loads and Stress, Weight and Balance, and Control and Towing, and considers Performance, Stability and Control, and Dynamics. These studies were conducted under the authority of Contract Number DA 44-177-TC-779, dated 21 June 1961.

Four basic configurations of the Flexible Wing Cargo Glider were established. All four were of the same design family, but with payload capacities of 250, 1,000, 4,000 and 8,000 pounds each. Specifications MIL-A-8861 and 8862 were used as a guide for design criteria for each of the configurations. To the extent practicable, the high standards for safety of flight for manned flight vehicles were maintained.

In connection with this Report, preliminary information prior to study from TRECOM indicated that limited effort should be expended in the design and analysis of the cargo compartment. This report, therefore, does not give a complete evaluation but presents only preliminary data on the cargo compartment.

Table I

FLEXIBLE WING CARGO GLIDER GENERAL DATA

	250#	Payload Version				8000#
		1000# Folding Pylon Air Drop	1000# Cable Air Drop	1000# Rigid Structure	4000#	
Over-all Length	108	197	248	197	387	551
Over-all Width	122	233.50	242	207(0°)	412(0°)	586(0°)
Over-all Height	133	266	170	266	530	754
Flight Configuration "	42.50	71	71	71	125	136
Folded Configuration "	73.25	148	275	148	276	380
Folded Configuration "	67.50	71.75	66.50	115.50(0°)	213(0°)	302
Keel Length (in)	103	207	242.40	207	412	586
Wing Area (Flat Plan f_1^2)	53	208	234	208	833	1666
Body Length) Less (in)	105	162	162	162	231	342
Body Width) Handling (in)	24	54	54	54	81	93
Body Height) Gear (in)	24	53.50	53.50	53.50	72	98
Cargo Compartment Length (in)	48	96	96	96	168	252
Cargo Compartment Width (in)	23	48	48	48	72	75
Cargo Compartment Height (in)	23	36	36	36	60	75
Cargo Volume (ft ³)	12.50	96	96	96	400	800
Wheel Base (in)	41.50	86	86	86	140	279
Wheel Tread - Front (in)	40	67	67	67	113	125
Wheel Tread - Rear (in)	40	67	67	67	80	90
Static Ground Clearance (in)	4.00	4.00	4.00	4.00	4.50	4.00
Empty Weight (lb)	118	499	422	479	1642	2973
Gross Weight (lb)	368	1499	1422	1479	5642	10973

IV. CONCLUSIONS

Flexible Wing Cargo Gliders are technically feasible.

The configurations of the Gliders of this concept are operationally suitable for logistic applications. Point and/or offset delivery is feasible. Operational and economical aspects are compatible with limited warfare. The system is adaptable to movement of bulk material, equipment, or personnel in total war. The payload capability of air and rotor craft standard in the inventory of the U. S. Army is increased several times, without serious degradation of specific speed and range. Air and rotor craft now limited to courier or liaison missions may profitably perform in the logistical transport role through increased payload capability.

High ratios of payload to structural weight and overall simplicity may be achieved, thus answering lower procurement and maintenance cost of logistic transport and permitting use of towed gliders without additional trained personnel. Glider systems may be utilized with manual, automatic, or remote command control.

The gliders described in this report are capable of STOL operation. The gliders defined are adaptable to shipboard operations.

The standoff delivery capability can decrease attrition rate of the towing vehicles. The remote guidance feature permits point delivery.

The adaptability of the glider to air drop offers advancement in vertical envelopment operations.

A single tow vehicle is compatible with several glider sizes.

V. INTRODUCTION

The development of the flexible wing, providing an extremely lightweight aerodynamic lifting surface, represents a major advance in the field of aerodynamic structure. Among numerous applications of the flexible wing concept, the Flexible Wing Cargo Glider has received major attention.

Unlike the conventional wing composed of a rigid skin covering and a forming structure, the flexible wing is composed of a membrane of flexible material which is attached to three supporting members. The center keel and the two side members, or leading edges, are joined at the foremost point to define a triangular envelope. The edges of the flexible membrane are continuously attached to the leading edges and keel, and the wing system is joined to the body of the vehicle by means of rigid or cable structural members. The flight path of the flexible wing vehicle may be controlled by shifting the center of gravity of the vehicle with respect to the center of pressure of the wing.

Early NASA subsonic and supersonic wind tunnel and model flight tests have demonstrated the feasibility of the concept. To further demonstrate the concept and obtain full scale test data, Ryan designed and built a manned utility vehicle incorporating this principle. Flight tests have recently been completed, and the vehicle was moved to NASA's Langley Field facility to undergo extensive wind tunnel testing.

The experience and test data derived from study of this vehicle, and its obvious structural weight, power, and cost advantages, suggested this concept as a satisfactory solution to the air logistics problem. The tremendous lifting capability at low speeds of the flexible wing vehicles indicated the necessity for a suitable power source match. In consideration of the draw bar pull capacities of the helicopters in the low speed regimes, a combination of the two produced the ideal team. Through the use of the helicopter as the towing vehicle of a separate payload carrier, greater operational versatility

is achieved. The mission of the helicopter is not limited to one particular operational role, nor is the limitation to one particular category of the cargo glider.

Four basic configurations of the Flexible Wing Cargo Glider evolved from the study program. The payload capabilities of the family of vehicles range from 250 to 8,000 pounds each. The gliders are configured to accommodate logistical materiel ranging from high density, high priority, to low density items and equipment. Combat or wounded personnel may be transported. The 250 and 1,000 lb. payload gliders are capable of being air launched from a fixed wing aircraft, and are particularly adaptable to unconventional warfare for point delivery of personnel and material. Each of the gliders features a "standoff" delivery capability and may be directed to the landing point by remote control. The folding and removable features incorporated in the design of the wing fulfill the requirements for shipboard operations and facilitates concealment once the glider is in the battle area. The design of the bodies and landing gear is directed toward rapid loading and unloading of cargo. Further, the gliders may be towed on the ground by motor tractors for point delivery and cargo dispersal.

The final report of the program completed under the requirements of Contract No. DA 44-177-TC-779 reveals the findings in the areas of design, performance, stability and control, loads and stress, weight and balance, and control and towing systems.

Since the mission role and payload capability of the towing vehicle is increased manifold, the operational suitability, technical feasibility, and economic compatibility of the Flexible Wing Cargo Glider concept are clearly demonstrated.

VI. METHOD OF APPROACH

Basic philosophy for the initial design includes the following:

The design criteria shall be based on the requirements, where possible, of MIL-A-8860 (ASG) and applicable specifications.

Strength requirements shall be based on MIL-A-8860 and 8861 where applicable. Model specifications shall be prepared for flight and landing strength criteria based on the above two specifications.

Dimension parameters shall be established on payload capabilities for each of the four basic configurations of 250, 1,000, 4,000 and 8,000 pounds.

Wing loading (W/S) of 5 to 7 pounds per square foot shall be considered.

Cargo compartments shall be sized for cargo densities of 10 pounds per cubic foot.

Rigid standards of design practices compatible for man-carrying vehicles shall be adhered to, where possible.

Each configuration shall be inherently rugged and have strength compatible with the requirements of normal ground and air operations.

Vehicles shall be inherently stable while under tow and during free-flight. Vehicles shall be equipped with a simplified, self-contained control system for the free-flight modes.

The thrust horsepower requirements for tow of the gliders will be compatible with the thrust available of designated towing vehicles common to the inventory of the U. S. Army.

The Flexible Wing and supporting structure shall be foldable and collapsible.

The 250 and 1,000 pound gliders shall have the capability of being air launched from the AC-1 Caribou airplane for point delivery operations.

Loads and strength characteristics and requirements were developed through standard methods. This data relies largely on scale model wind tunnel programs and data obtained from flight tests of the Ryan manned utility test bed.

Weight analysis was made by calculation from drawings, statistical or empirical evaluation, and vendor quoted weight for hardware items.

All performance calculations were accomplished by hand except the helicopter-towed glider performance which was programmed on the IBM 650 digital computer. The performance was computed using standard equations, and only a brief description will be given here.

Lift and drag characteristics were obtained from unpublished NASA wind tunnel data. The cargo body and wing supporting structure drag was developed from experimental and theoretical data on each component. All component drag coefficients were adjusted and based on flat plan wing area. These data were reduced to thrust horsepower required, and equivalent flat plate area for use in further calculations.

Free glide performance included computation of lift/drag ratios, rates of sink, and maximum horizontal glide range. Only the glide range is presented in this summary which shows the effect of variation in wing loading and body drag.

Take-off distances were computed using an empirical equation. Since it was possible to duplicate the published take-off distances of the L-20A alone, calculated take-off distances of the combinations is representative of the actual case. It was assumed that the glider accelerated on a hard surfaced runway at maximum lift/drag ratio. At take-off airspeed, the wing incidence of the glider was increased and the craft lifted. When towed with an L-20A, the glider becomes airborne first. When towed with a helicopter, it was assumed that the helicopter first rises vertically a few feet above the ground, then accelerates horizontally with the glider in tow.

Landing distances (ground run only) were calculated at a touch-down speed of about 42 knots which corresponds to a lift coefficient slightly less than maximum.

Rates of climb and a basic mission were calculated for the L-20A towing a 250 lb. and 1,000 lb. payload vehicle. It was assumed that the L-20A carried no internal payload but did carry a co-pilot and fuel. The thrust horsepower required for the glider was added to the thrust horsepower required for L-20A alone for computations involving the combination. The cruise portion of all missions was computed at 99% of the long range cruise specific range. The gliders were assumed to be released at cruise altitude before the L-20A returned. Allowance for typical fuel reserves was made.

The following glider helicopter combinations were investigated using the digital computer program.

Helicopter	H-23D	HU-1B	H-34A
Glider Payloads - Lb.	250	1,000	1,000
	1,000	4,000	4,000
			8,000

Power required, rates-of-climb, and mission profiles were calculated and are presented for three cruise altitudes. The helicopters were loaded with full fuel, zero payload, and a crew of two. L-20A missions were computed at 99% of the long range cruise specific range and the gliders were assumed to be released at cruise altitude.

The stability and control analysis of the cargo glider is separated into four categories - dynamics and statics, in free flight and during tow.

In the lateral-directional mode analysis concentrated on dynamic stability in free flight and during tow. Since static directional stability affects this mode critically, this particular area of statics was also scrutinized. The possibility of dynamic coupling between glider and helicopter was studied through analysis of the frequency content of the system.

In the longitudinal mode emphasis was on study of static trim conditions since the necessity of including the non-linear induced drag contribution to the static margin introduces unconventional terms

A study was made of a proposed lateral control system for optimum hinge lines. Equations for static lateral pilot control forces are developed, and hinge moment coefficients computed.

A method of mechanizing velocity dependent on longitudinal tow hinge moments for trim was studied, and bridle length and attach points for tow near the cruise condition were determined.

The control and towing systems were developed through analytical design after investigation of the loads and control forces, based on requirements established from the performance and stability analysis. Standard methods and equations determined the power requirements and size for the components of the control systems. The power sources were selected for each of the vehicle configurations considering operational compatibility and cost.

VII. TECHNICAL DISCUSSION

Description of the Vehicle Configuration

The Flexible Wing Cargo Gliders studied during this program are based on four basic configurations sized for payload capacities of 250, 1,000, 4,000 and 8,000 pounds each. Alternate configurations of the 250 pound and the 1,000 pound versions were also studied for air drop applications. These have been configured to permit deployment from fixed wing aircraft of the AC-1 type by ejecting the glider from external stores pylons or from the cargo compartment rear access door. An alternate version of the 1,000 pound payload vehicle was considered, with a flexible or cable supporting structure between the wing and the body instead of the rigid truss framework of conventional configurations. The following paragraphs summarize the design features, system for control, and towing of each of the configurations. A summary is also given of the air drop configuration and modifications required for the towing vehicles.

The 250 Pound Payload Cargo Glider

The 250 lb. payload Flexible Wing Cargo glider is suitable for the transportation of high density and/or high value logistic material, such as small arms ammunition, food rations, medical supplies.

The vehicle consists of a cylindrical container, 2 feet in diameter and four feet long, attached by a quick release device to a tubular framework equipped with a four wheel landing gear and suspended from the wing. The front wheels caster for ground maneuvering.

Radio control of the glider's actuators controls the wing in pitch and roll.

Quickly removable end cones permit rapid loading and unloading of cargo. The container, when detached from its framework, and with or without end cones removed, may be rolled away to point of use.

Small cargo nets across the ends of the drum confine the cargo to a given area when the end cones are removed.

The Flexible Wing consists of a keel, leading edge members, spreader bar, and wing membrane.

A housing on top of the container contains the control actuators, radio controls, batteries, and the ground contact switch.

The ground contact switch is operated as follows: The switch, and its connecting cable with drogue attached, is housed in a small canister. A radio signal causes a solenoid to release the drogue which pulls the cable from its reel. The cable trails until the drogue contacts the ground. This operates a release which sends the wing into a flare maneuver prior to landing.

Pitch control is achieved by means of a cable from a wing keel, around a drum and pulley located in the equipment housing and back to the wing keel. An actuator rotates the drum and reels the cable in from one direction and pays it out in the other direction, thus moving the wing around its pitch axis.

Roll control is achieved by rotating the wing about a roll axis. The roll actuator is located on the top of the equipment housing.

The air drop operation consists of suspending two 250 pound vehicles under each wing of an Army AC-1 (Caribou) aircraft out-board of the engines and stowing an additional six vehicles in the aircraft's cargo compartment. These vehicles are deployed from the open cargo compartment door.

The over-all dimensions are: length of keel 103.50 inches with a wing sweepback of 50° , and length of cargo container 105 inches.

The Flexible Wing can be disassembled and all parts folded and stowed in the cargo container, protecting the wing and structure of the glider while in storage.

The 1,000 Pound Payload Cargo Glider

The 1,000 pound payload Cargo Glider is suitable for the transportation of relatively high density and high value logistic material.

1

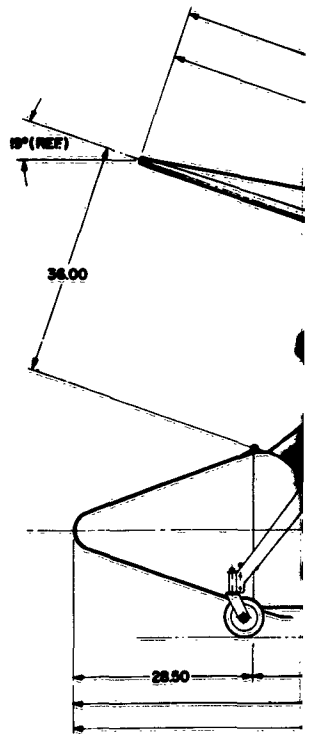
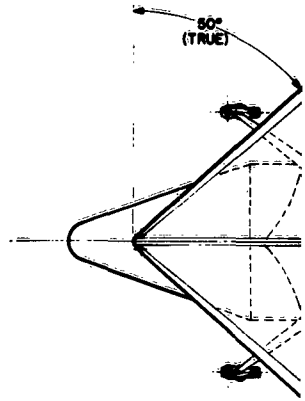
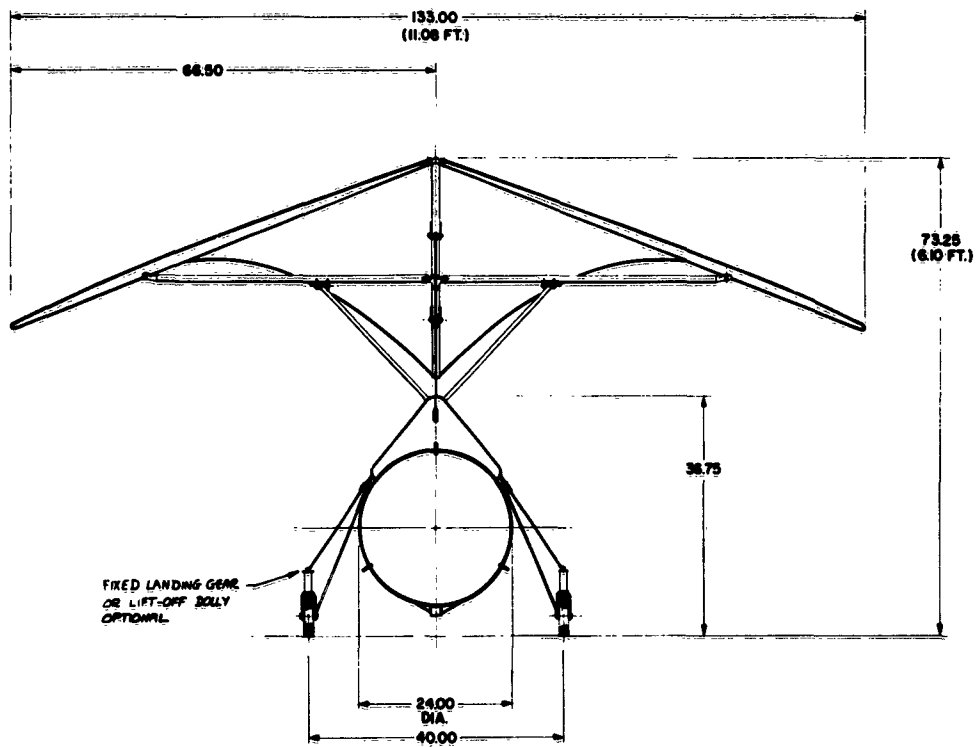

Dwg. 1 - B063-0007 General Arrangement - 250 I

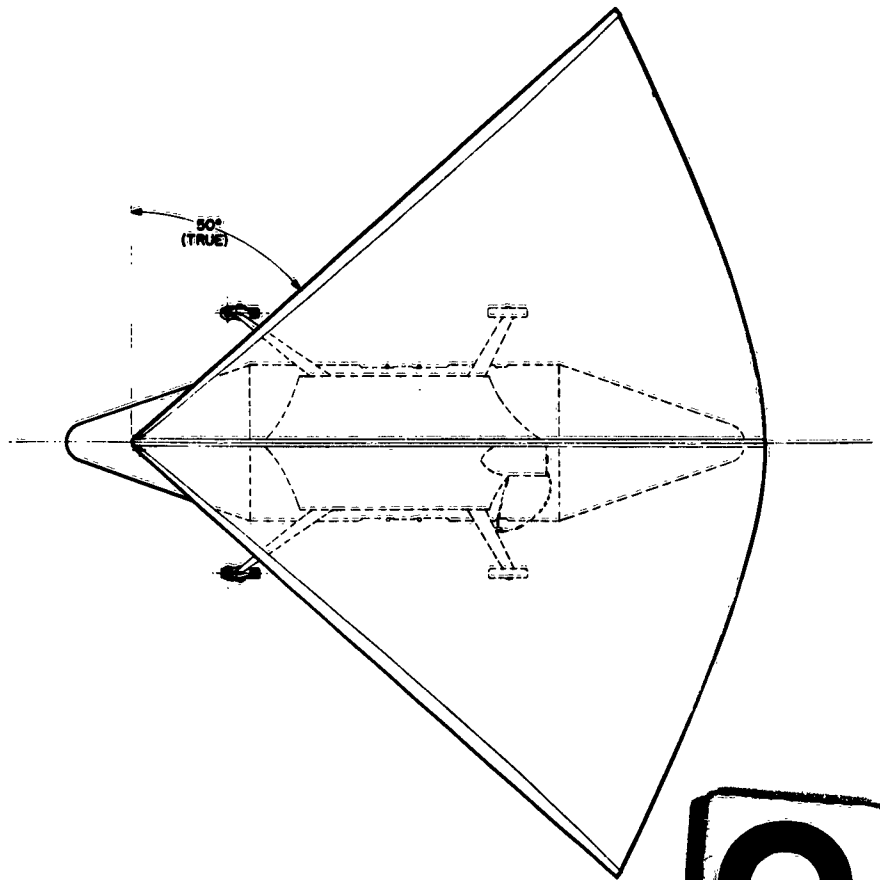

2

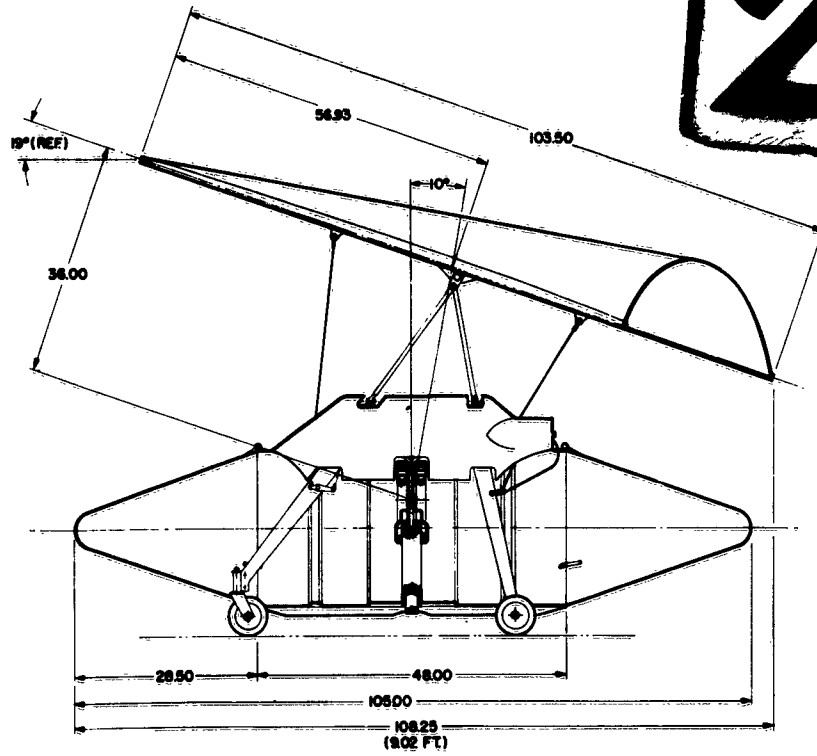
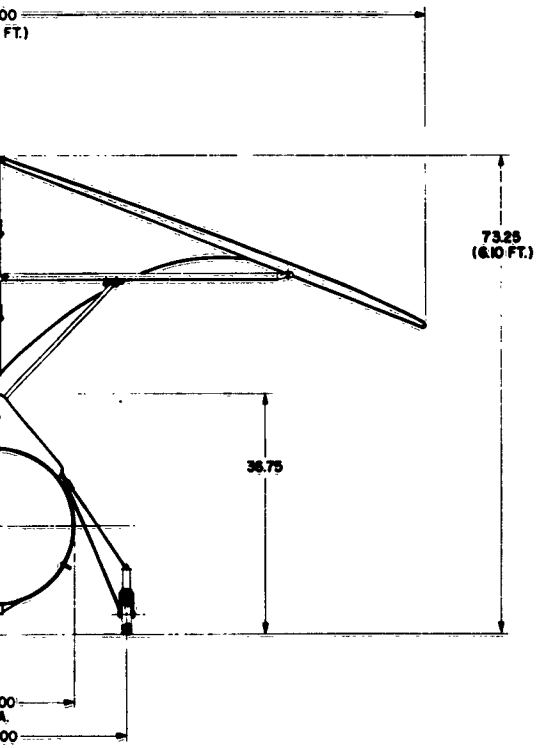

Dwg. 1 - B063-0007 General Arrangement - 250 Lb. Payload Flexible Wing Cargo Glider

1

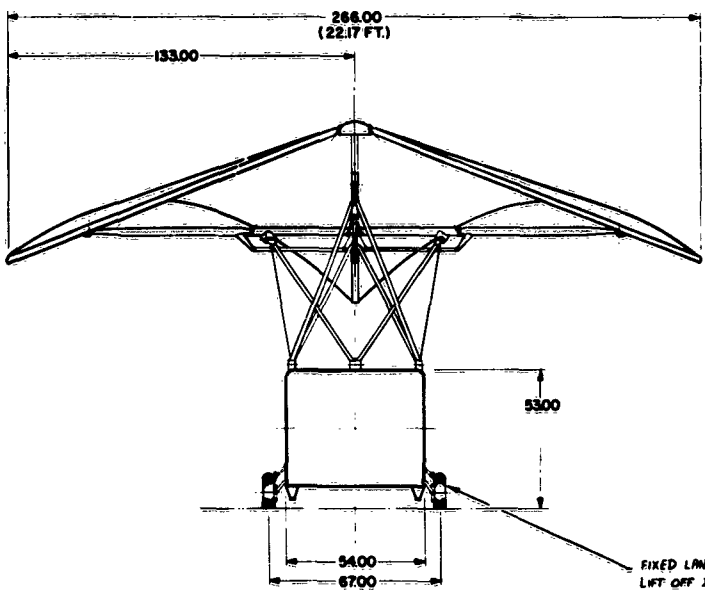
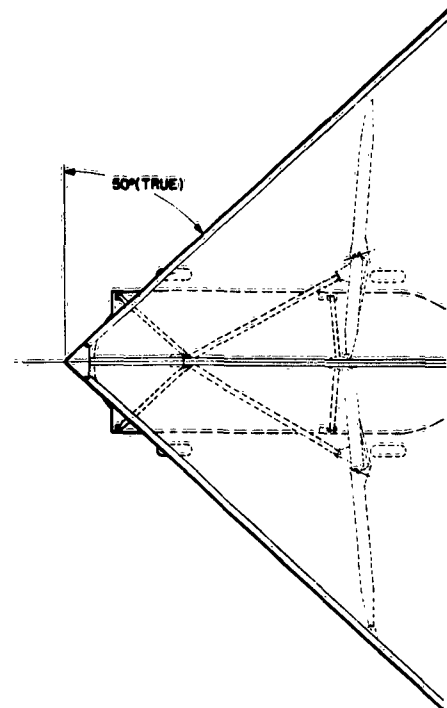

FIXED LANDING GEAR OR
LIFT OFF IDOLLY OPTIONAL

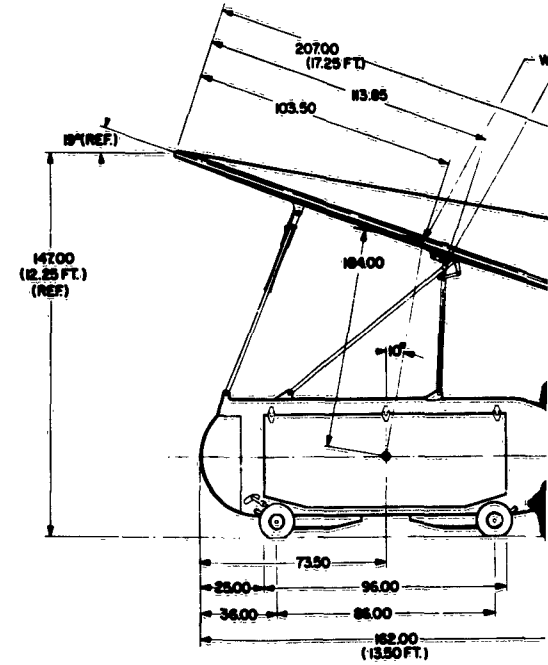

Dwg. 2 - B063-0013 General Arrangement - 1000 Lb. Flexible Wing Ca

2

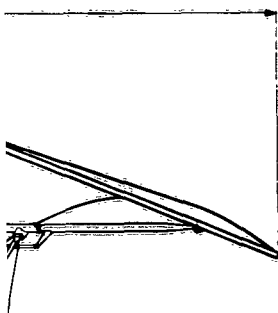
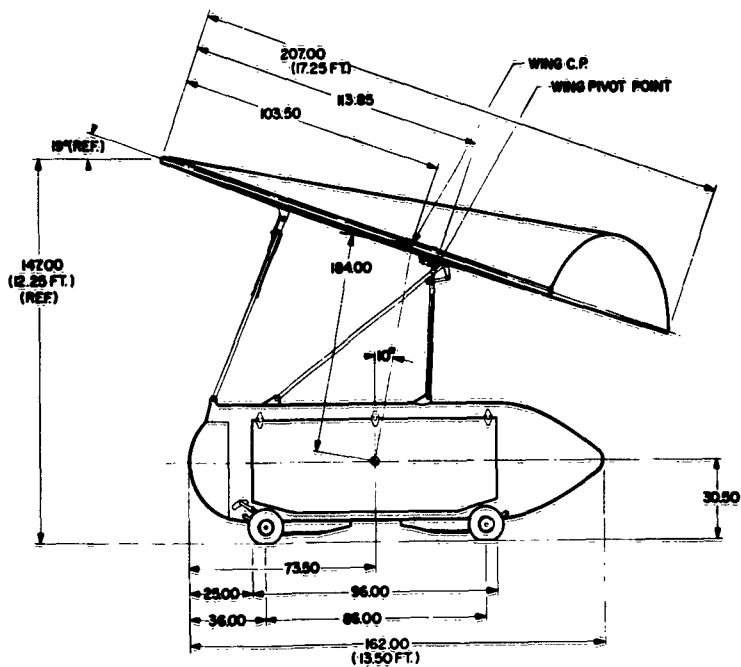
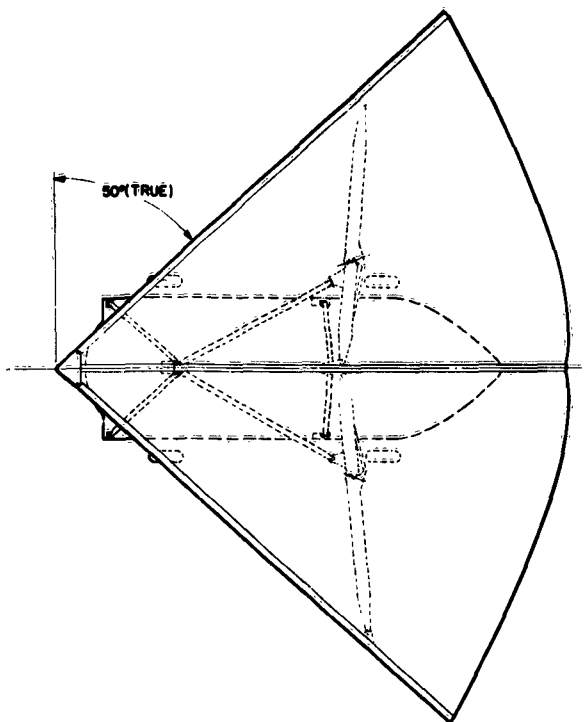

83.00

FIXED LANDING GEAR OR
LIFT OFF IDOLLY OPTIONAL

Dwg. 2 - B063-0013 General Arrangement - 1000 Lb. Flexible Wing Cargo Glider

1

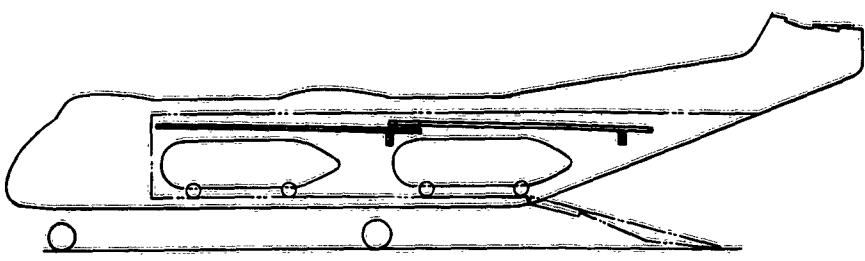

LOADED PARACHUTE AIRCRAFT (16)

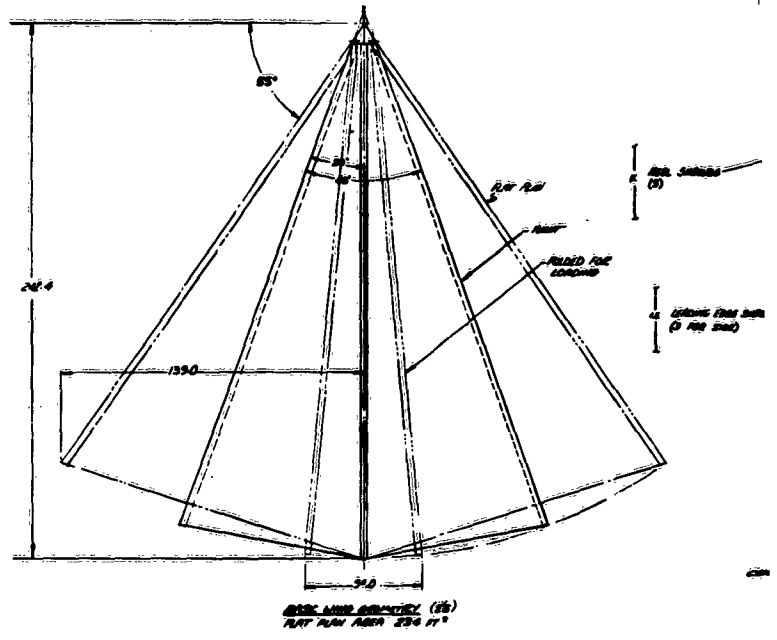
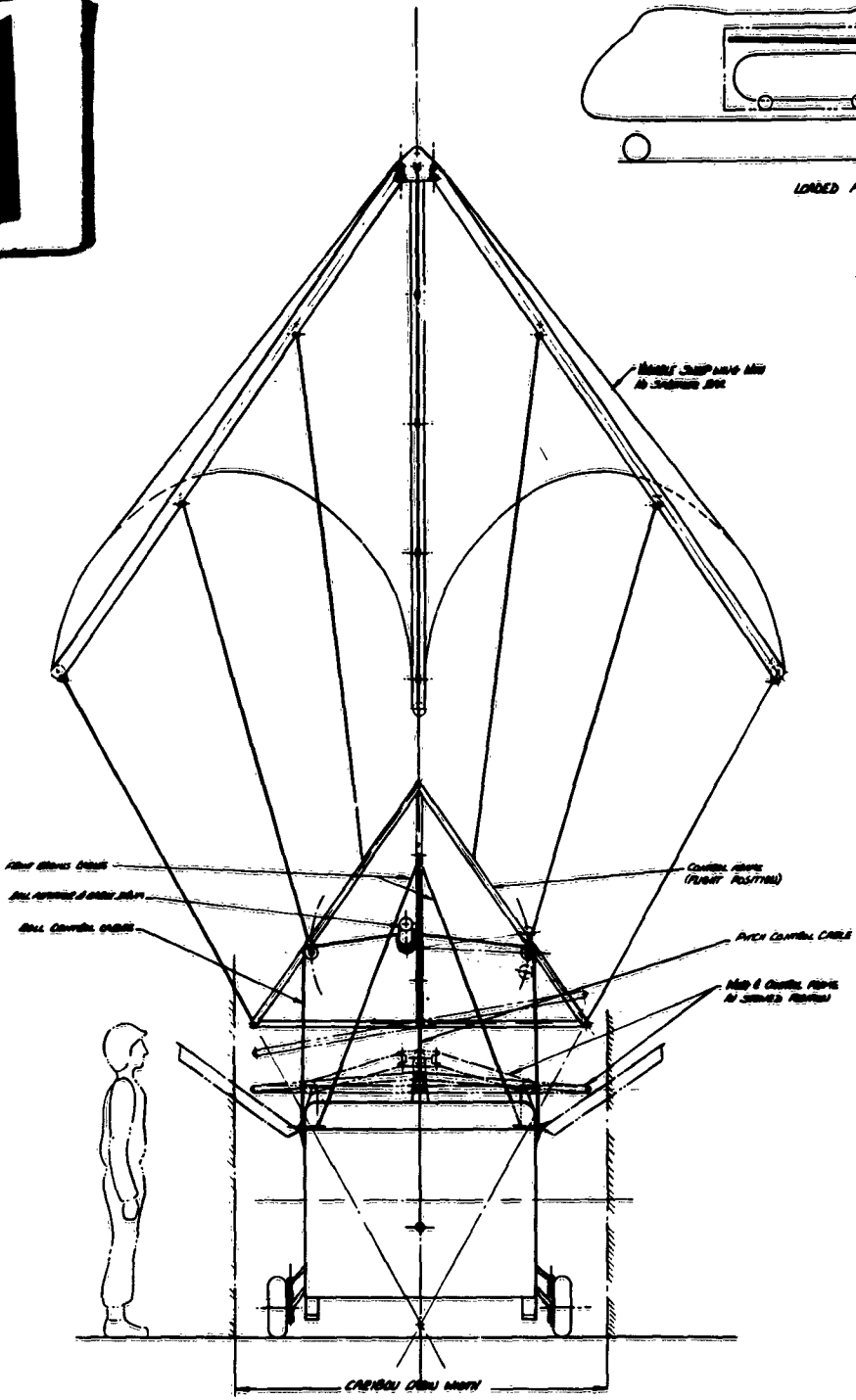

PARACHUTE (16)

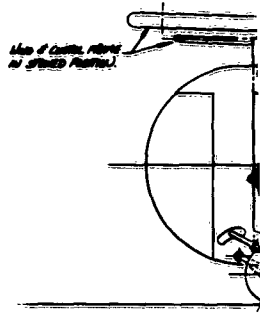

- NOTE 1. MASS CONFIGURATION & AERODYNAMIC DATA BASED ON APOLLO WIND TUNNEL TEST REPORT**
2. FOR BODY STRUCTURE PROFILES SEE 8063-0045
 3. MASS WEIGHT 1400 LB
 4. PAYLOAD 1000 LB
 5. PARACHUTE LENGTH 342.9 IN
 6. PARACHUTE AREA 234 FT²
 7. PARACHUTE LENGTH 618.17 FT
 8. PARACHUTE VOLUME 56 FT³
 9. PARACHUTE CHARACTERISTICS WITH 4 FT x 3 FT

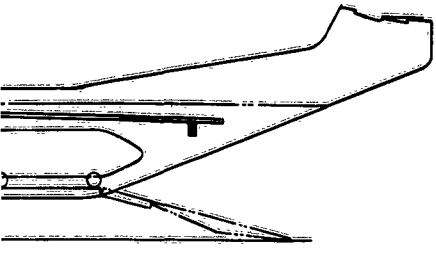

(3b)

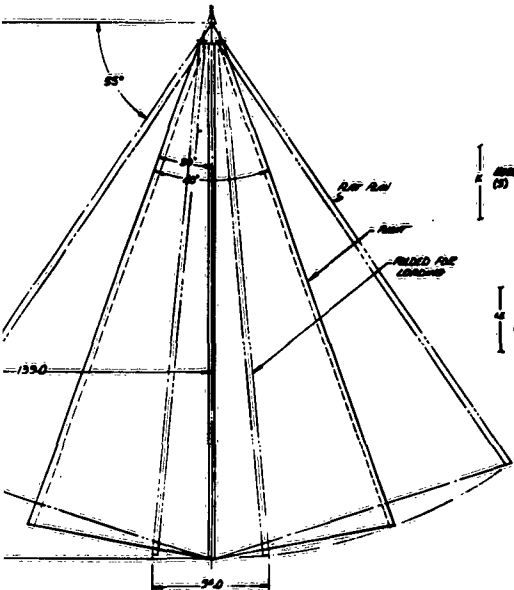

BASE AREA ESTIMATE (25)
PLAT PLAN AREA 234 ft²

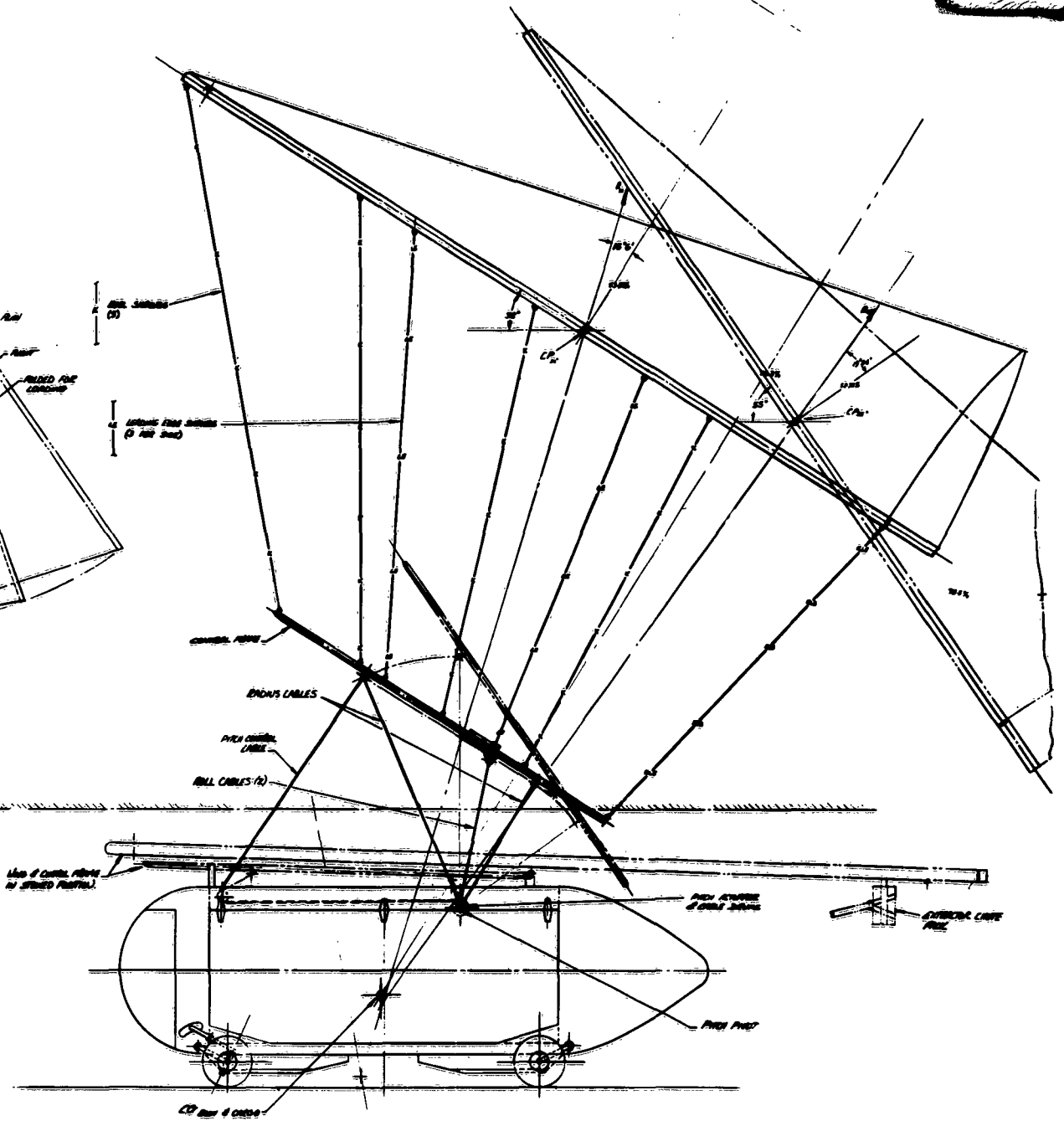

CONFIGURATION & AERODYNAMIC DATA BASED
WIND TUNNEL TEST REPORT
BODY STRUCTURE PROPOSALS SEE B063-0045
WEIGHT: 1400 LB
SPAN: 100.0 FT
LENGTH: 25.0 FT
PLAN AREA: 234 FT²
LOADING: 6 LB/FT²
NO COLLAPSE: 56 FT²
NO COMPRESSIBLE IMPULSIONS @ 11.4 FT x 3.0 FT

Dwg. 3 - B063-0027 1000 Lb Payload Glider Air Drop Version With Cable Wing Suspension Study

The cargo container is rectangular in cross section, 3 feet high, 4 feet wide and 8 feet long. The 96 cubic foot volume results in a 10 lb. per cubic foot loading. The container has a door in each side hinged at the top through which palletized cargo may be loaded. Two pallets loaded with 500 pounds each may be accommodated. Lightweight fairings front and rear provide streamlining. A four wheel landing gear is provided, with the front wheels castering to allow maneuvering on the ground. Two skids, the length of the underside, carry the loads and protect the bottom of the container.

A foldable tubular structure connects the wing and the cargo container in configuration 1. The geometry of the tubes allows the wing and its supporting structure to fold on top of the cargo container, permitting the complete unit to be stowed in an aircraft for air deployment.

The wing consists of a keel, left and right hand leading edge members, a spreader bar, and the wing membrane.

The vehicle is controllable in pitch and roll by means of actuators that change the angle of the wing in relation to the cargo container. Radio signals from the ground or accompanying aircraft cause the actuators to change their position.

The air drop and sequence of deployment are discussed in the final paragraph of this Section.

The 1,000 pound Flexible Wing Cargo Glider is shown in three configurations. One (with a foldable but not collapsible wing) is intended only to be towed off the ground by an aircraft. Towing is accomplished by a bridle connecting the wing keel and the top of the cargo container, with a single cable going forward to the tow aircraft.

The second configuration has a wing with rigid keel and leading edges (but without spreader bar). It is connected to the cargo container by a system of cables. This system can be collapsed completely and will be deployed in the air from an aircraft cargo compartment.

The third configuration is both foldable and collapsible and may be towed off the ground, or air launched from the cargo compartment of an aircraft.

1

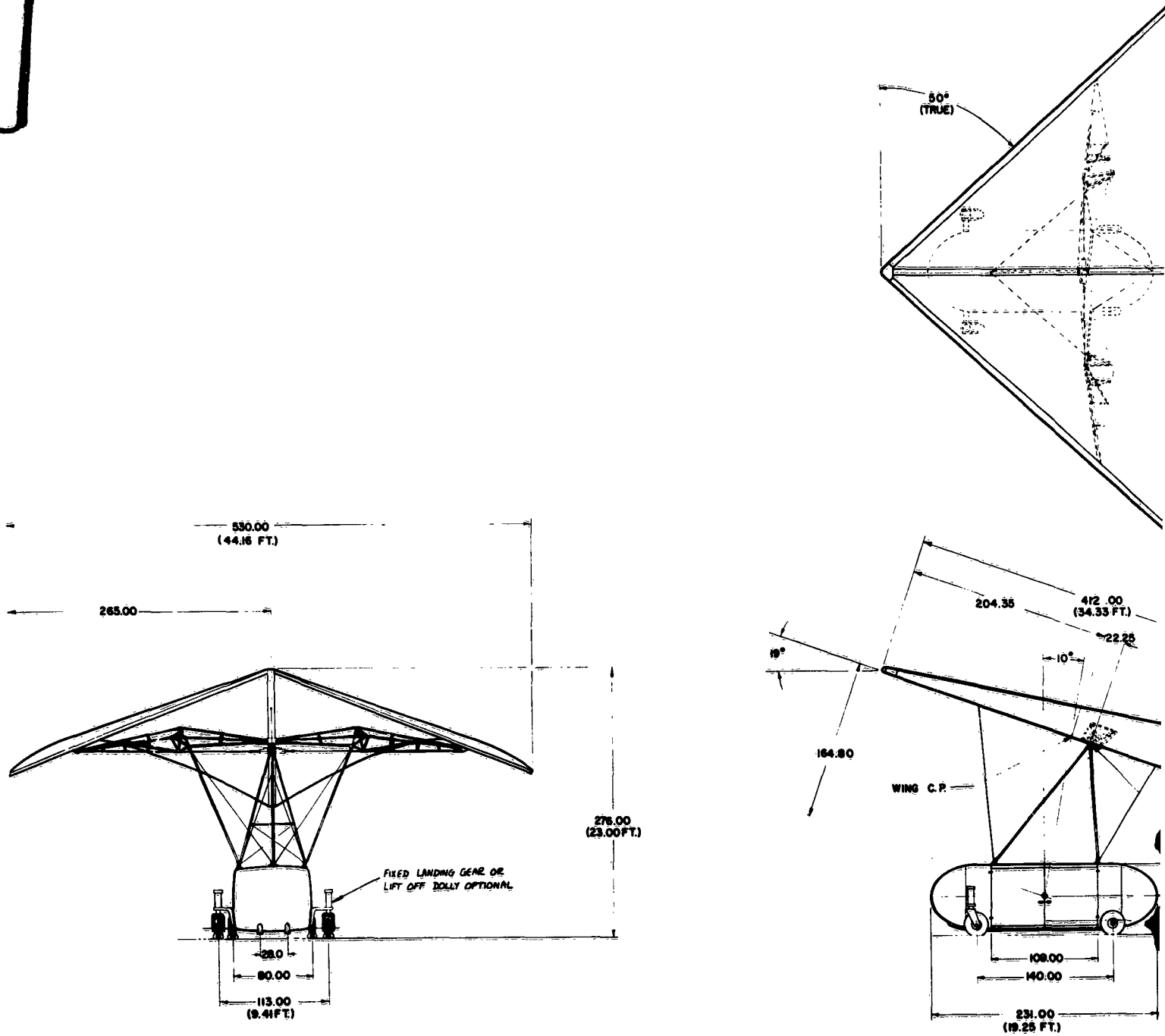

Dwg. 4 - B063-0017 General Arrangement - 4000 Lb. Payload Flexible Wing (

2

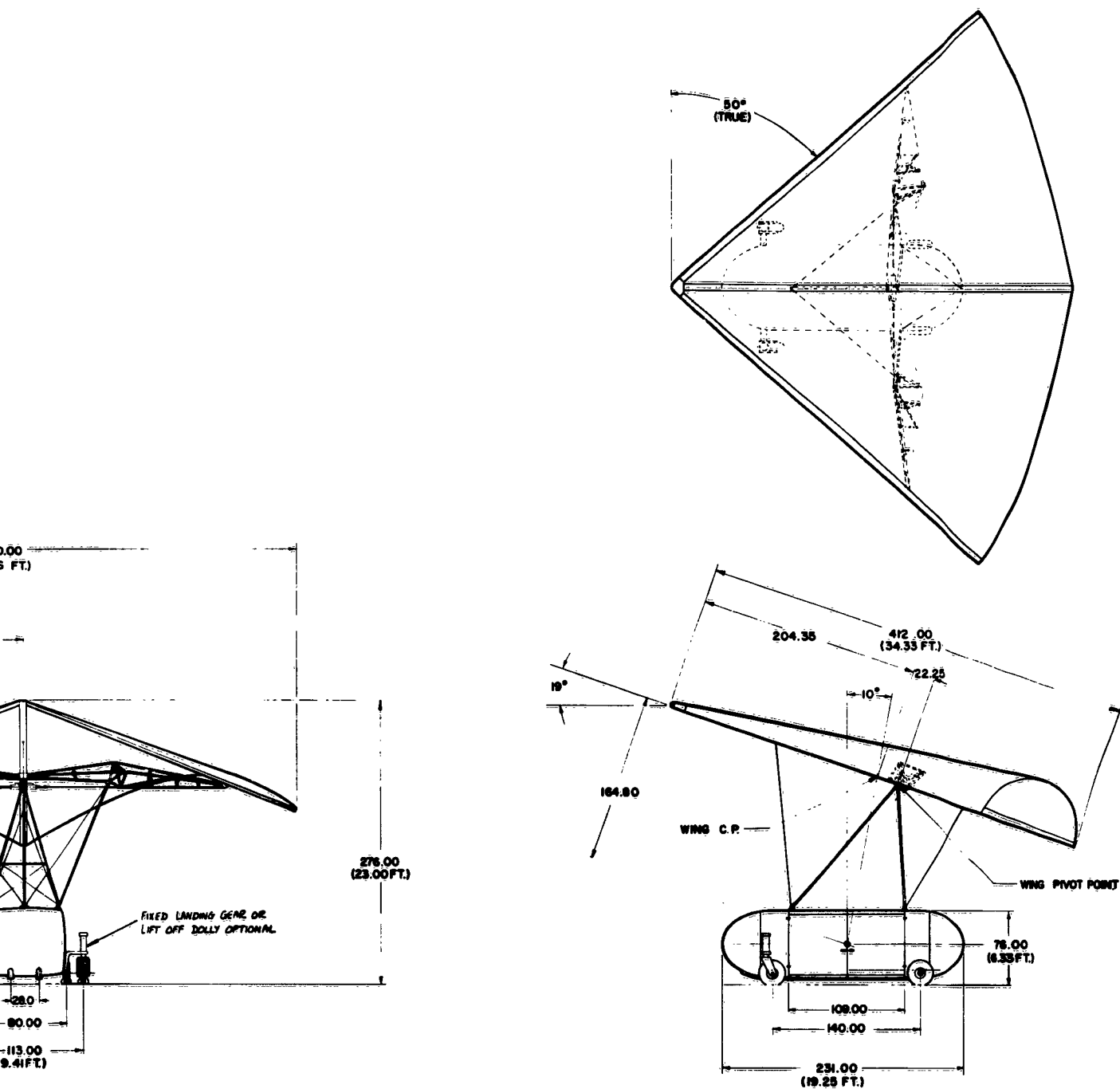

Dwg. 4 - B063-0017 General Arrangement - 4000 Lb. Payload Flexible Wing Cargo Glider

container. The actuator installed in the top of the cargo container reels in and pays out a cable attached to the forward end of the keel to give control around the pitch axis. Remotely controlled radio signals command the actuators to change position.

The dimensions of this towed vehicle are: wing keel length 34.33 feet long, sweepback angle 50° , and length of the cargo container 19.25 feet.

The 8,000 Pound Payload Cargo Glider

The 8,000 pound payload Flexible Wing Cargo Glider is suitable for the transportation of logistic material loaded on pallets. In addition, the litters and their medical attendants, troops and a large variety of vehicles may also be transported.

The cargo container is rectangular in cross section and is 6' 3" wide, 6' 3" high and 22' 0" long. The approximate 860 cubic foot volume of the container produces about a 10 pound per cubic foot loading. The rear tail cone swings aside and a ramp may be lowered to permit loading and unloading of vehicles. Two doors in the right hand side are hinged at front and rear and latched at the center, providing a large area for loading palletized cargo from fork-lift trucks. The floor is covered by a cargo tie down fitting grid and is stressed for 2,000 pounds per square foot cargo loading. Five standard 40" x 48" pallets, each holding 1,600 pounds, may be accommodated. Standard troop seats may be installed for 26 troops. As an alternate load, 16 litters and 6 attendants or ambulatory patients may be carried.

A four wheel landing gear is provided. The front wheels are full castered to allow maneuvering on the ground. Two skids run the length of the underside of the container to carry the load and protect the bottom of the container.

The structure connecting the Flexible Wing to the cargo container is made up of a combination of tubes and cables. Control of the vehicle is accomplished through the support structure.

The Flexible Wing consists of a built-up sheet metal keel of rectangular cross section, left and right hand leading edge members of streamline cross section, a welded tube spreader bar assembly incorporating roll control, and the wing membrane.

1

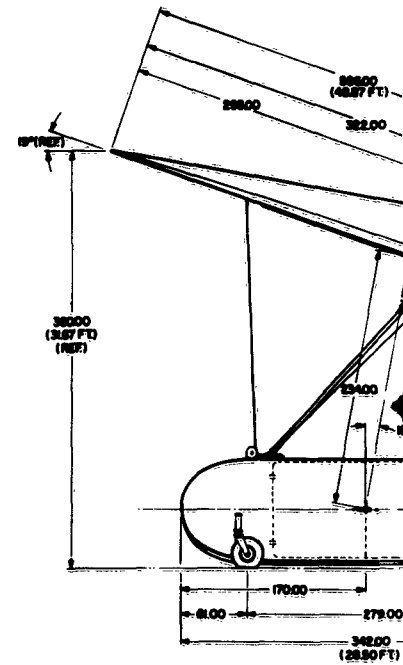
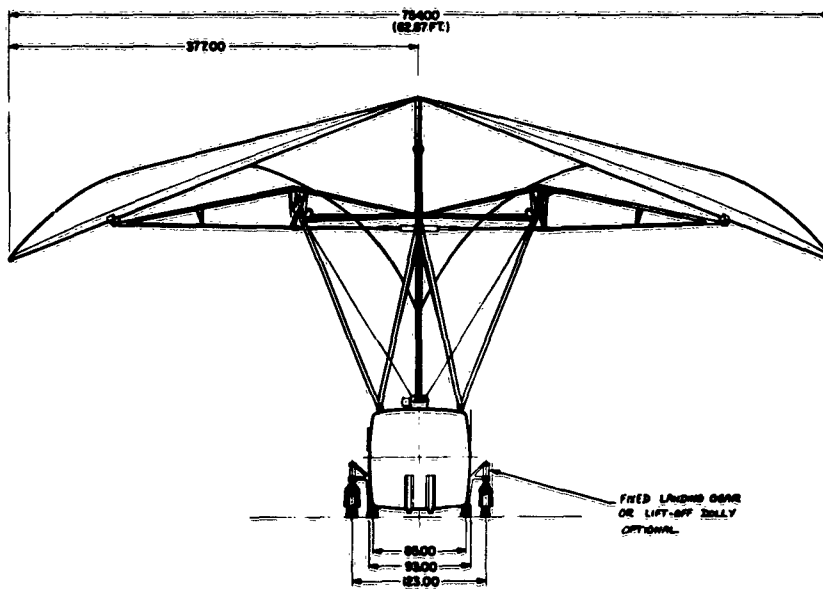
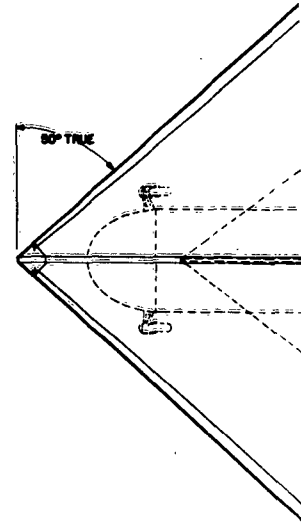

Dwg. 5 - B063-0018 Gen

2

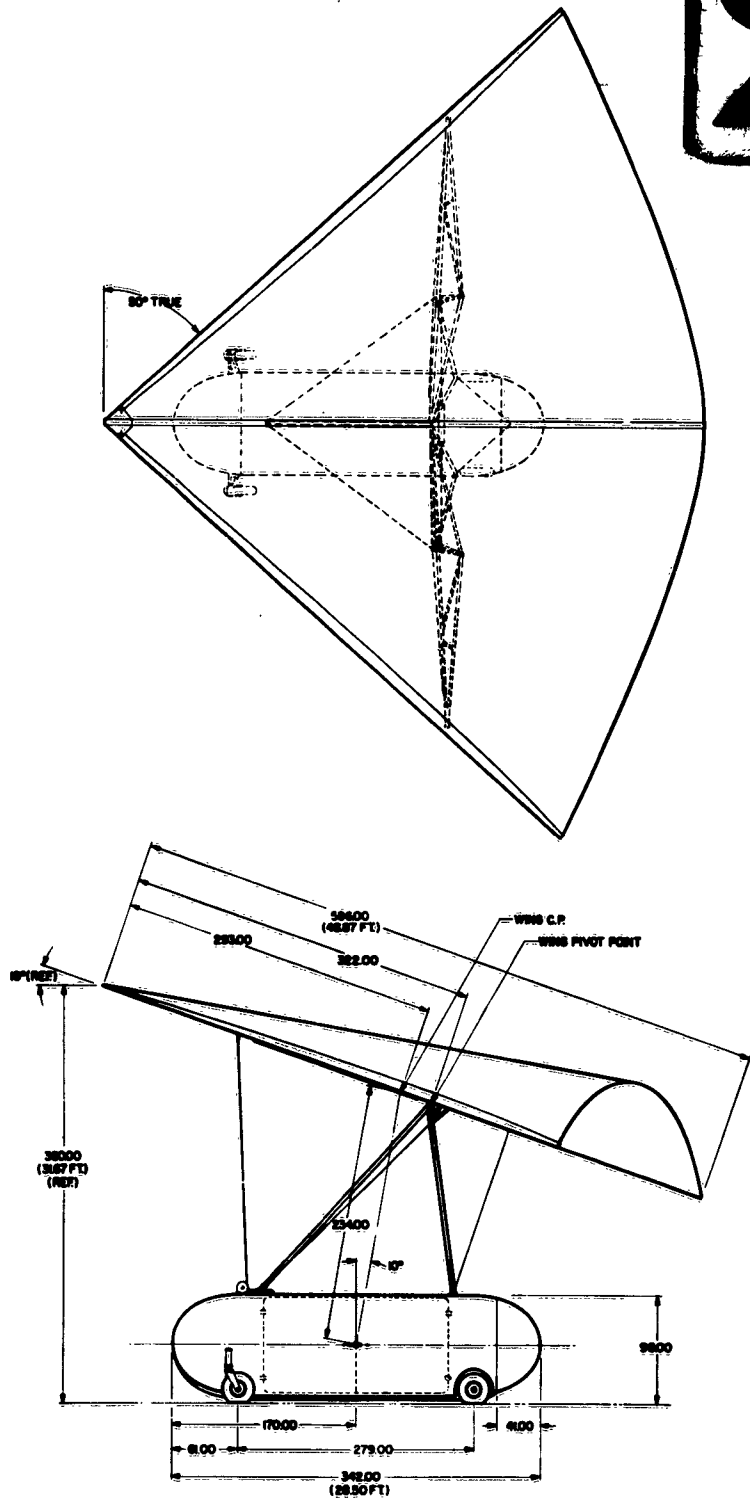
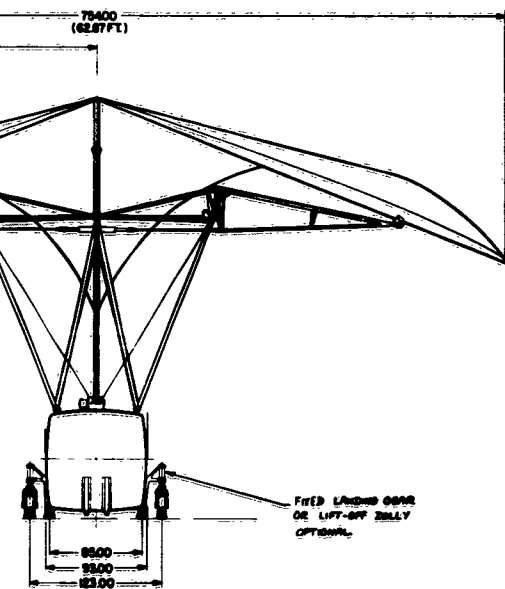

Dwg. 5 - B063-0018 General Arrangement - 8000 Lb.

The vehicle is controllable in pitch and roll by means of actuators changing the angle of the wing in relation to the cargo container. The actuators (incorporated as a part of the spreader bar assembly) serve to provide roll control. A third actuator installed in the top of the cargo container reels in and pays out a cable attached to the forward end of the keel to give control around the pitch axis. Radio signals for remote control cause the actuators to change position.

The tow bridle consists of a cable from the forward keel and two cables at the forward corners of the cargo container brought together at a common point, continuing as a single cable to the tow aircraft.

The principal dimensions are a keel length of 48.87 feet with a sweepback angle of 50° , and a cargo container length of 28.50 feet.

Air Drop Configurations

Alternate configurations of the 250 and 1,000 pound payload vehicles achieve an air drop capability for point delivery of logistic material from fixed-wing cargo aircraft. For purposes of the study, the AC-1 Caribou aircraft was considered as the launching aircraft for the gliders. The Caribou has the capacity to handle two of the 1,000 pound vehicles internally, or ten of the 250 pound gliders, carried internally and externally on pylon stores racks. The ejection of the 1,000 pound vehicle through the rear access door of the cargo compartment of the Caribou was considered the most difficult to accomplish and was therefore used to establish the drop criteria. The following conditions were used for the time and motion studies of the air deployment:

Drop Altitude	1,500 feet above the terrain
Drop Speed	200 Knots EAS
Payload	1,000 pounds
Gross Weight of Glider	1,498 pounds

The configuration of the glider is standard except for the wing structure and the wing erection mechanism. The wing and the supporting structure must be fully collapsible, and include actuators for erection and deployment of the wing.

A drag chute is used to extract the vehicle through the rear door of the aircraft. A drag chute having a drag coefficient of 1.4 based on a projected diameter of six feet will produce a force of 5,370 pounds, giving the glider an initial acceleration of 3.6 g relative to the launch aircraft. The glider and the aircraft will separate .44 second after the restraining cable of the glider has been released by the initial pull of the drag chute. A static line attached to the glider and to the launch aircraft will initiate a timing mechanism to unlock the wing from the stowed position. The wing then begins the sequence of erection. A dynamic pressure sensitive brake is incorporated in the wing erection-deployment mechanism to govern the rate of deployment of the wing. The drag chute decelerates the glider. The brake retards wing erection until the vehicle has reached the limiting design speed. At the beginning of wing deployment, the glide path of the vehicle will be approximately negative 50 degrees. When the wing is fully open, the keel slide-locks and the drag chute jettisons. The glider will then assume the normal glide path for conventional towed configurations. The elapsed time from launch to wing deployment is approximately 5.5 seconds.

1

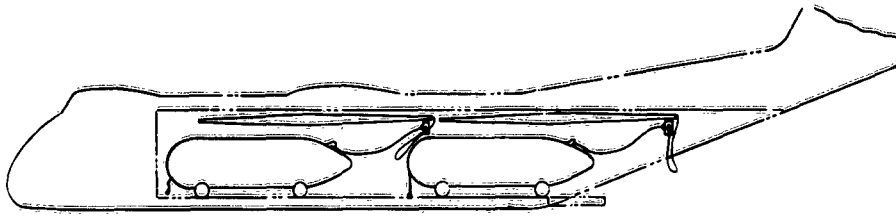

PHASE 1 - OPERATOR PULLS CABLE RELEASE CABLE

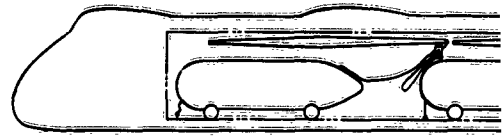

PHASE 2 - CABLE FRAME PULLS FROM AIR END AND OVER STATIC LINE OPENS CHAIR

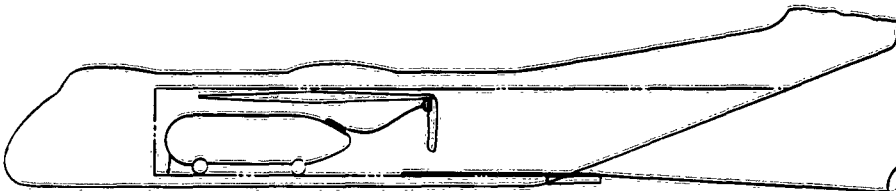

PHASE 3 - AIRS WALKER LAUNCHES CHAIR INTO AIR
AND RELEASES
LAUNCH BEAMS FREE FROM DOWN
SLIDE SUPPORTS FROM AIRCRAFT & BARRIAGES

WEDDOP FROM AC-119 AIRCRAFT AIRCRAFT
(1/8 SCALE)

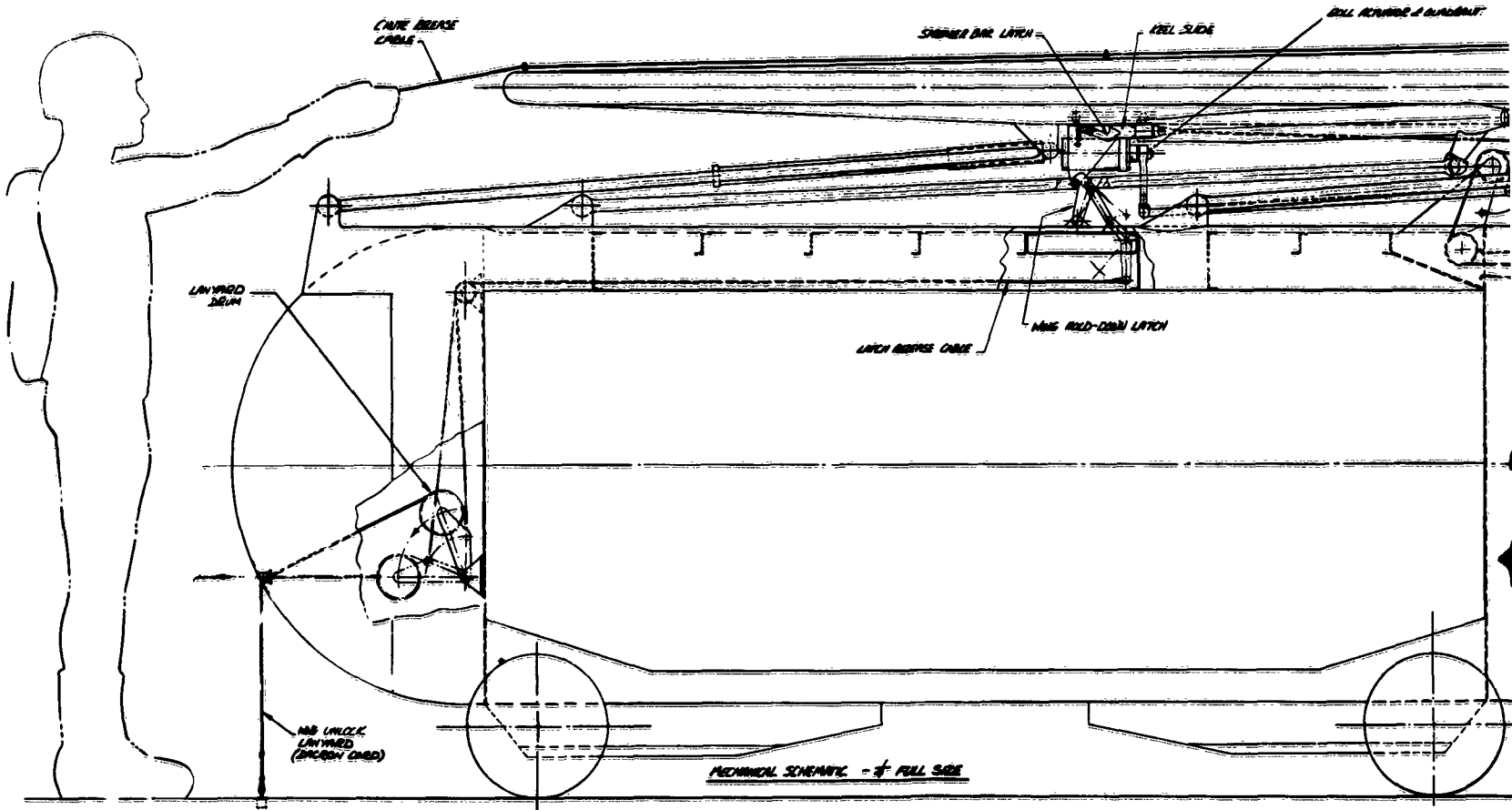

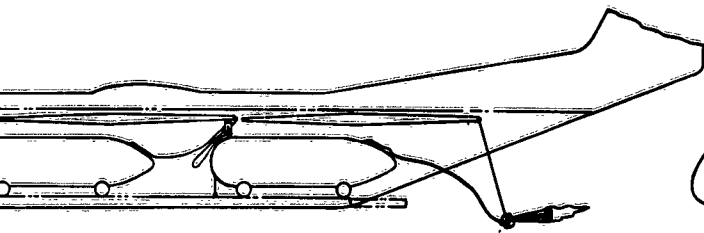

PHASE 2. CHUTE PACK FALLS FROM AFT END OF KEEL
 RP CHUTE STATIC LINE DEPLOYS CHUTE

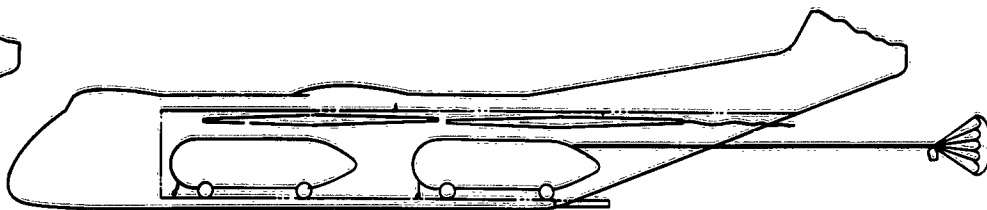

PHASE 3. CHUTE FULLY DEPLOYED
 GLIDER BRANGS RELEASED

DROP FROM AC-119 AIRCRAFT
 (75 SCALE)

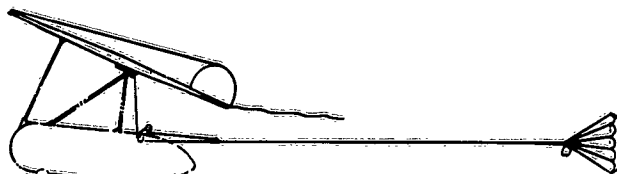

STAGE 5. CHUTE PACK FALLS FROM AFT END OF KEEL, RATE OF WING SPREAD LIMITED
 BY DESENSITIVE AIRFLOW BRANGS TO PREVENT EXCESSIVE AIR-STRUCTURE
 LOADS; KEEL SLAM LOCKS; DRAG CHUTE JETTISON.

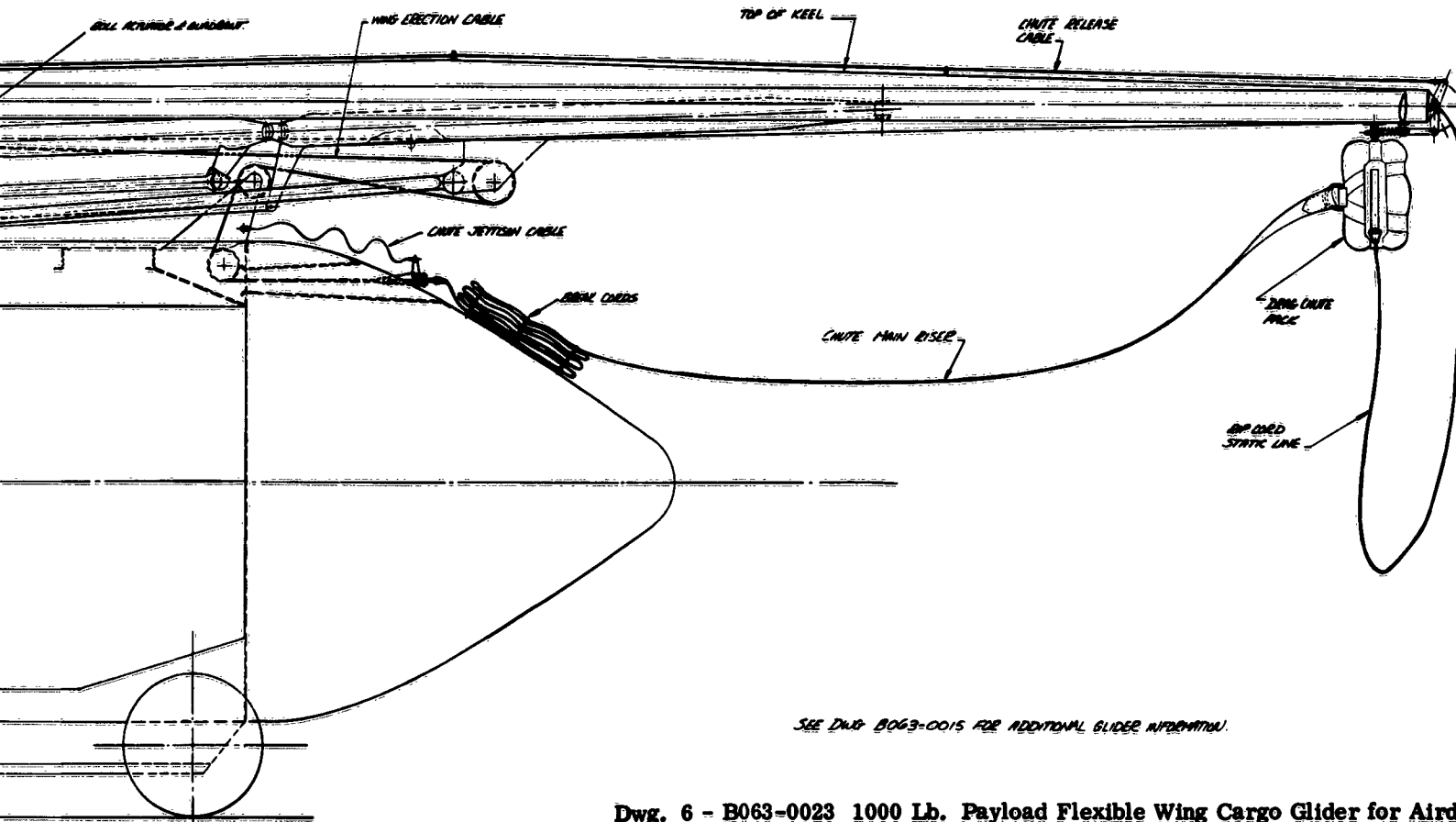

SEE DWG B063-0015 FOR ADDITIONAL GLIDER INFORMATION.

Dwg. 6 - B063-0023 1000 Lb. Payload Flexible Wing Cargo Glider for Airdrop Wing
 Deployment System (Folding Pylon)

Design Criteria

Each of the configurations of the Flexible Wing Cargo Glider is structurally of the same design family, varying only in size to accommodate the design payloads. Exceptions are certain features of the 250 and 1,000 pound payload versions facilitating more extensive requirements of wing folding and erection for the airdrop application. A preliminary investigation was made of a design of a 1,000 pound payload glider using a flexible or cable attachment of the wing to the body.

Since current specifications for design criteria relating directly to towed gliders are non-existent, MIL-A-8860 and applicable specifications were used to formulate criteria for the configurations presented. Specification MIL-A-8861 and -8862, Vehicle Strength and Rigidity, Flight Loads and Vehicle Strength and Rigidity, Landing and Ground Handling Load, respectively, were modified for the Flexible Wing Application. Copies of the Model Specifications appear in the Technical Discussion of Volume II of this report.

Analysis of the loads based on wind tunnel data obtained from NASA and from Ryan experience with the manned utility test bed vehicle, shows that gust conditions, rather than maneuvering loads, will dictate the critical design points. The following table establishes the maximum structural design conditions for each of the four basic configurations. All values are based on a wing loading of 6 pounds per square foot and at a speed for maximum gust intensity of 100 knots.

Configuration by Payload Size	250	1,000	4,000	8,000
Gust Load Factor g	4.7	3.9	3.0	2.7

A study of the design requirements for the air drop configurations revealed that the practical approach was to delay wing erection until the vehicle had decelerated to a velocity of 147 and 134 feet per second for the 250 and 1,000 pound configurations respectively, thereby matching the above indicated values for the maximum gust intensities.

During the study program the primary effort was directed toward the wing structural requirements and the design of the supporting structure and the controls. Only preliminary investigations of the body sections of the configurations were made, since factors of

manufacturing cost, sizing for cargo accommodations, and expected attrition rate will have significant influence on the final design. For purposes of the study, conventional aircraft structure was used.

Experience and laboratory test results from previous programs at Ryan were used in establishing the properties and characteristics of the wing membrane material. Of several candidate materials studied, a polyester impregnated Dacron met all the requirements. A cold bonding process was used for joining the sections of the membrane.

The landing gear requirements were established to insure adequate ground stability and to absorb the loads generated from touchdown vertical velocities of 10 feet per second. The landing gear is basically of the quadricycle type, using oil-air shock struts on the forward gear, and torsion bar suspension on the rear gear. The 250 pound configuration varies, however, in that the gear is of the cantilever spring type and attached to the wing supporting structure. Final selection of the rolling members of the landing gear will depend primarily on adaptability to rough field conditions and flotation properties for a UCI rating in excess of 15.

Strength and Loads Considerations

The Stress and Loads analysis indicates the structural feasibility of the configurations. Conventional methods of analysis were used for the investigation. In accordance with previous verbal agreement with TRECOM personnel, the stress and loads study was primarily limited to the components of the flexible wing and the supporting structure. Factors other than optimum strength/weight efficiencies in the body structure will influence the final arrangements. In the major structural areas of the wing and the wing support structure, static and dynamic studies determined the critical loading conditions.

Load distribution on the wing membrane and the beams defined the shear and moment curves for the keel and leading edge members of the wing. Simplified bending and shear analyses were made on the wing elements to substantiate the design structure. The wing-to-body struts were considered as columns for loads induced by aerodynamic loads imposed on the wing.

The landing loads were calculated for a sink speed of 10 fps with an arbitrary load factor of 3 g. The required landing gear design does not impose impractical requirements structurally or mechanically.

Detailed strength and loads data will be found in Volume II of this report.

Weight Analysis

The weight and balance of the four basic configurations and the alternate cable support version were developed by acceptable methods of weight estimation. The data presented are compatible with the requirements of Specifications MIL-W-24140 (ASG) and MIL-STD-254 (ASG).

In addition to the weight, balance and inertia data presented in this volume and Volume II, an investigation was made of the effects on the c. g. of the AC-1 Caribou aircraft during airdrops of the gliders. No effects were noted from dropping the glider from the pylon mounted configuration, but there is a possibility that the forward allowable limit of c. g. location in the aircraft may occur in the internal mounted configuration. This condition can be overcome by shifting the c. g. of the basic aircraft aft, or relocating the forward glider to the center of the cargo compartment upon ejection of the aft glider.

Table 2

SUMMARY WEIGHT
STATEMENT

ITEM	CONFIGURATION BY PAYLOAD CAPABILITY				
	250#	1,000#	4,000#	8,000#	
WING	36.7	202.9	504.4	964.1	
BODY	32.5	171.1	782.5	1,408.7	
ALIGNING GEAR	23.4	60.7	162.3	257.5	
CONTROL SYSTEM	<u>25.1</u>	<u>64.0</u>	<u>193.0</u>	<u>342.2</u>	
WEIGHT EMPTY	117.7	498.7	1,642.2	2,972.5	
PAYLOAD	250.0	1,000.0	4,000.0	8,000.0	
GROSS WEIGHT	367.7	1,498.7	5,642.2	10,972.5	
CENTER OF GRAVITY (Percent of Keel Length)	42.8	43.0	42.7	43.5	

Description of Towing and Control Systems

The 250 pound payload glider may be towed by the L20-A Beaver or the H-23D Raven. The towing arrangement for the L-20 application is a single cable extending from a fitting located on the tailwheel bulkhead to the bridle attachment-point of the towed vehicle. The cable is Nylon and encases an electrical circuit providing power to a solenoid actuated release mechanism at the bridle apex of the glider towing bridle. An emergency release mechanism (manually actuated by the pilot of the towing aircraft) is in the attaching fitting of the aircraft. The towing system for the 250 pound payload glider and the H-23D combination are basically the same as described in the following paragraph for the standard configurations for helicopter towing.

The systems used for towing of the gliders by helicopter H-23D, HU-1A and H-34 are basically identical for all configurations and will be described here only in general terms. The towing vehicle is fitted with a bridle of cable construction, which attaches to the airframe at a point adjacent, and in alignment with the c. g. The bridle is in the form of two cables extending alongside the vehicle to a convergence point aft of the tail rotor of the helicopter. Necessary spreader bars and snubbing fittings prevent interference of the bridle with the tail rotor. A Nylon cable with a minimum length of 4.7 times the keel length of the wing of the towed vehicles, attaches the bridle of the towing vehicle to the bridle of the towed vehicle. The towing cable encases the wires of an electrical circuit used for actuation of the towing release mechanism. A manually actuated emergency release mechanism is incorporated in the attaching fittings of the bridle of the towing vehicle. The bridle length of the towed vehicle is calculated to be 92 percent of the wing keel length. The location of the attaching points of the bridle on the glider are computed from the equation $\frac{X}{C_r} = .094$ and $\frac{Z}{C_r} = .045$.

Control and guidance of gliders may be achieved by one of three, or a combination of the following:

(1) When the glider is under tow, control and guidance are through the vectored forces of the tow bridle geometry.

(2) Free flight control without directional guidance may be achieved by presetting the trim control for the prescribed glide

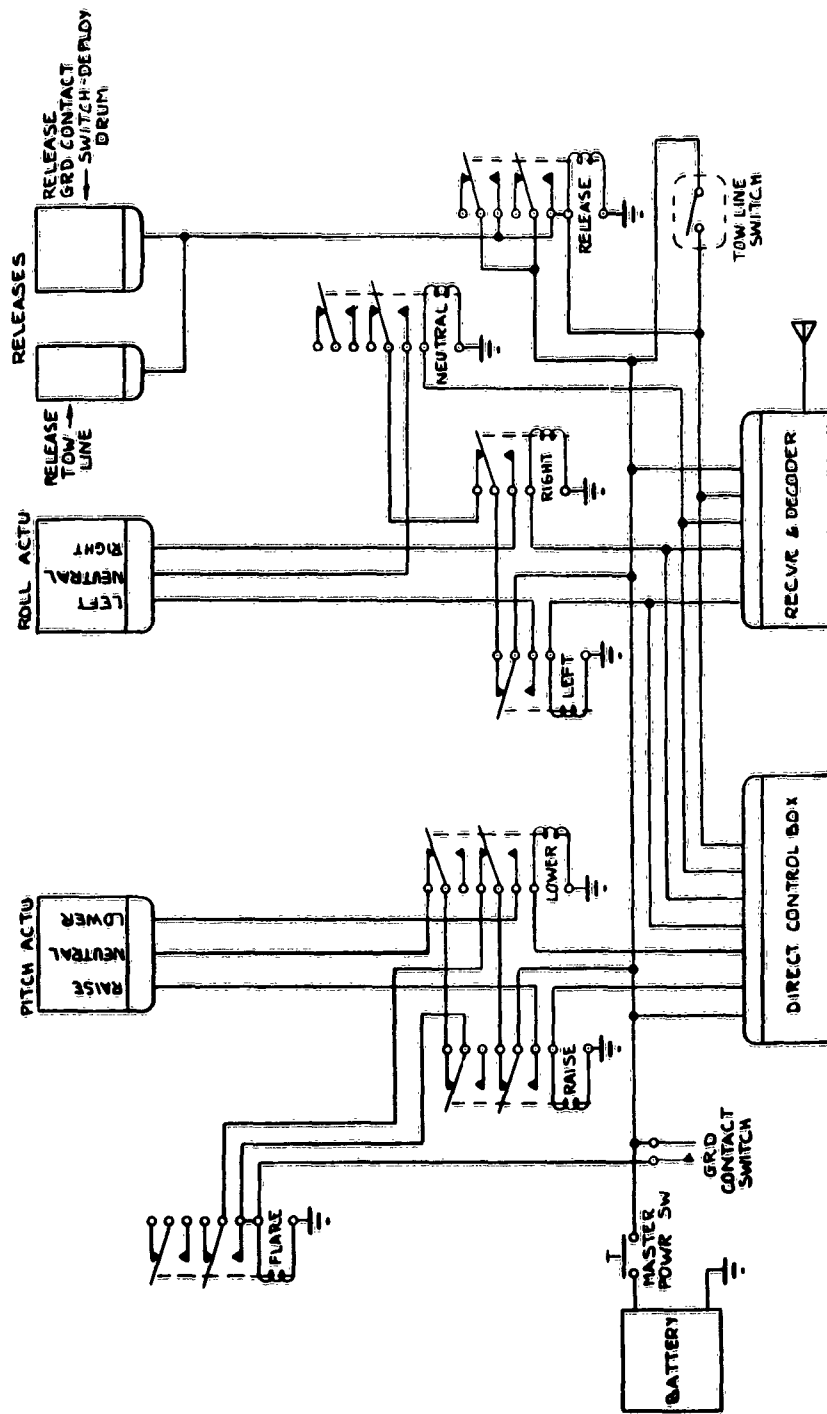

Schematic 1 B063-0003 (Sheet 1) Electrical Schematic 250 Lb. Towed Glider

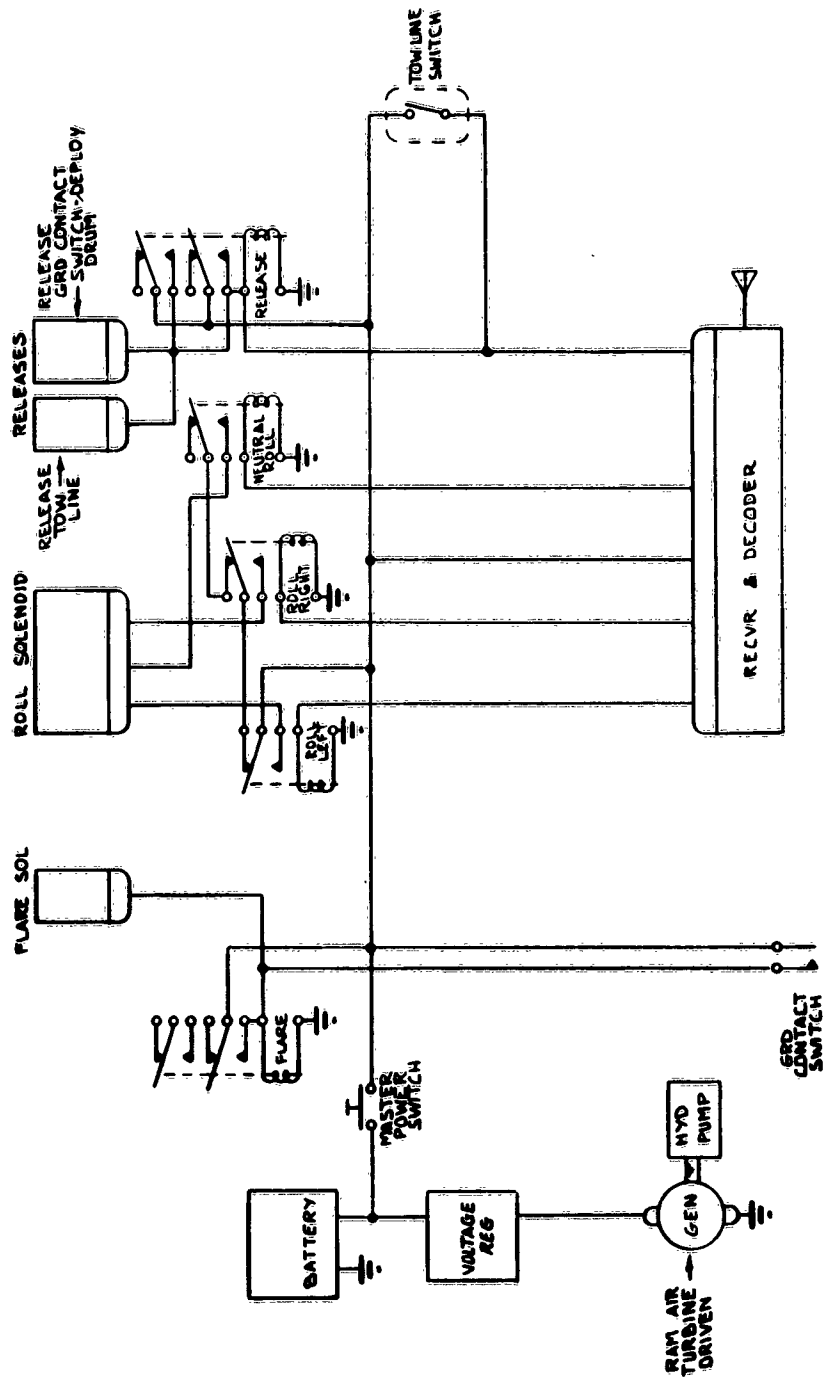

Schematic 3 B063-0003 (Sheet 3) Electrical Schematic 4000 & 8000 Lb. Towed Glider

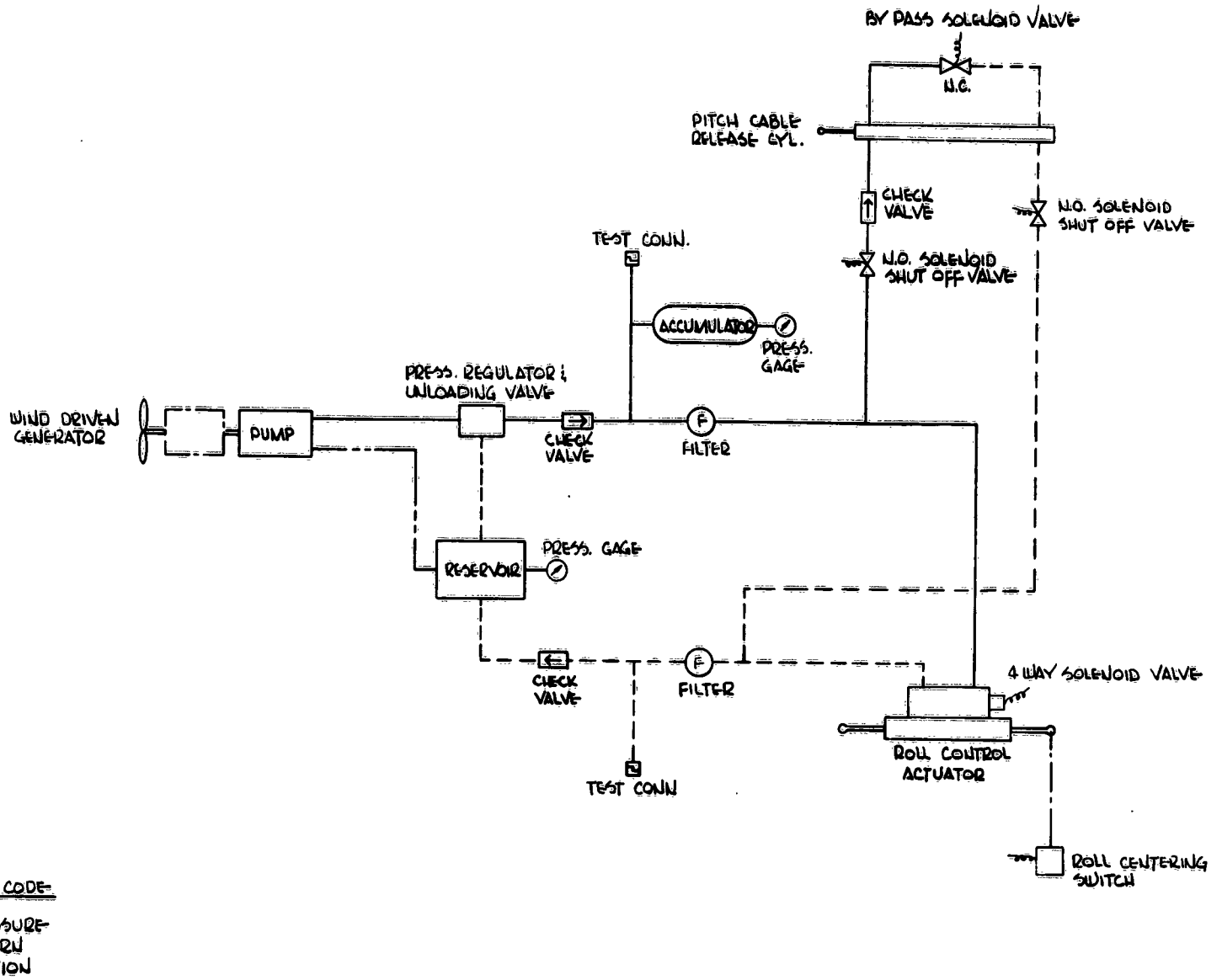

Dwg. 7 - B063-0031 3000 Psi Hydraulic Control System - 8000 Lb & 4000 Lb Towed Air Logistic Vehicle

slope and use of a pendant type, trailing ground contact switch. The pendant switch mechanism will trail at a predetermined distance and is enclosed in a canister. The switch assembly is ejected from the reeled-in position upon release of the towing bridle and is permitted to trail below the glider. Upon ground contact of the switch, a signal to the control system changes the wing incidence angle from 19 to 34 degrees which executes landing flare.

(3) Directional and longitudinal trim control is achieved by remote radio, and an electrical or hydraulic actuated control system. Control of the vehicle is achieved by wing deflection center of gravity shifts. The actuators of the control system are of two basic types, rotary for the electrically driven and linear for the hydraulically driven systems. The 250 and 1,000 pound payload gliders have electrically driven controls. The 4,000 and 8,000 pound versions have hydraulically powered systems. The electrical system is powered by standard aircraft 28 volt batteries with no in-flight recharge capability. Power for the hydraulic driven system is from a ram air turbine. Power for the control system is required only during free flight, and energy from the turbine is stored during towing. The transmitter for remote control is a standard ARW-55 with a power output of 25 to 40 watts, operating on a standard band of 406 to 420 mc. The transmitter and its allied equipment are standard FM type, and can transmit 20 channels of On-Off commands. The transmitter may be located on the ground or may be airborne. The receiver aboard the towed glider is a 2621/1805 receiver/decoder, a product of RS Electronics Corporation of Palo Alto, California, or equivalent. The effective range for remote control is in excess of ten miles line of sight.

1

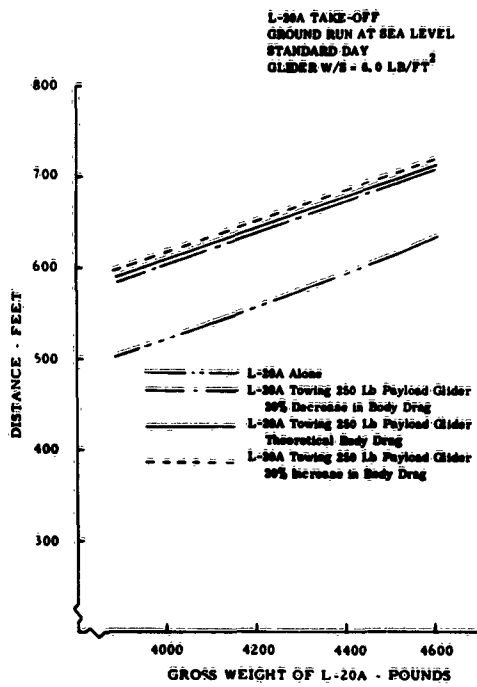

Figure 1

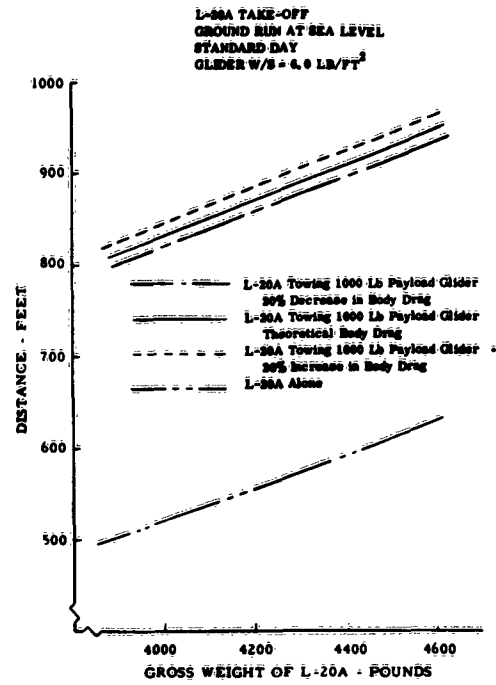

Figure 2

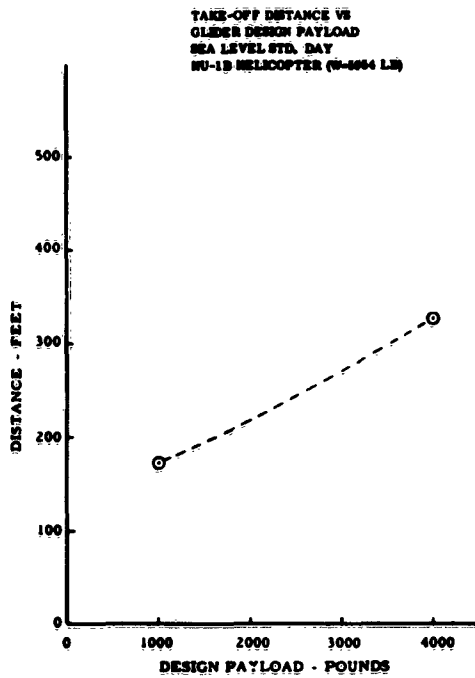

Figure 4

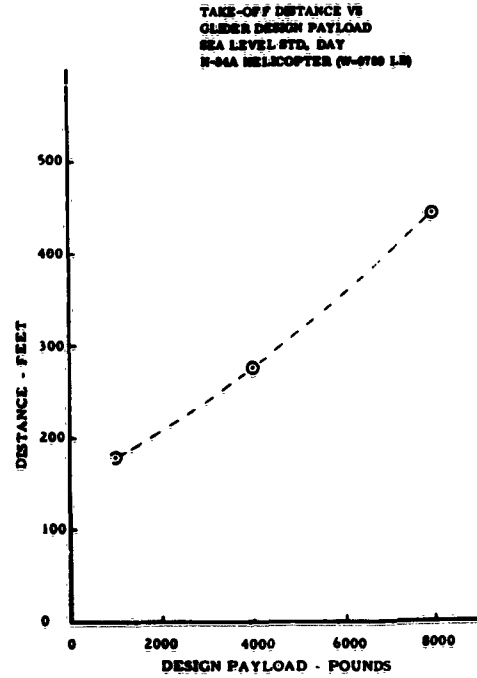

Figure 5

SEA LEVEL
LB/FT²

Payload Glider
by Drag
Payload Glider
Theoretical Body Drag
Payload Glider
by Drag

4600
POUNDS

**L-20A TAKE-OFF
GROUND RUN AT SEA LEVEL
STANDARD DAY
GLIDER W/S - 6.0 LB/FT²**

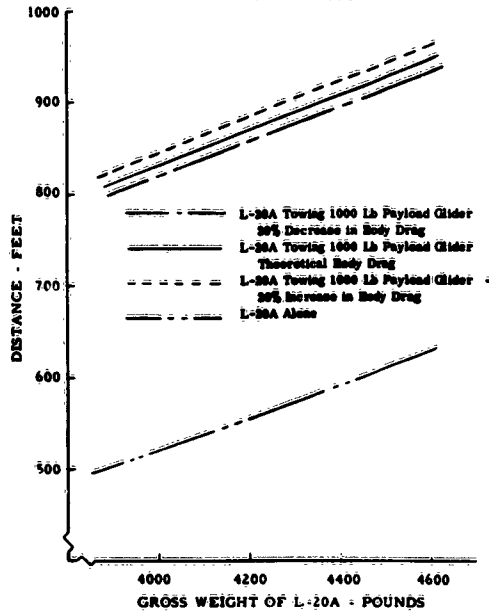

Figure 2

**TAKE-OFF DISTANCE VS
GLIDER DESIGN PAYLOAD
SEA LEVEL STD. DAY
H-23D HELICOPTER (W-2470 LB)**

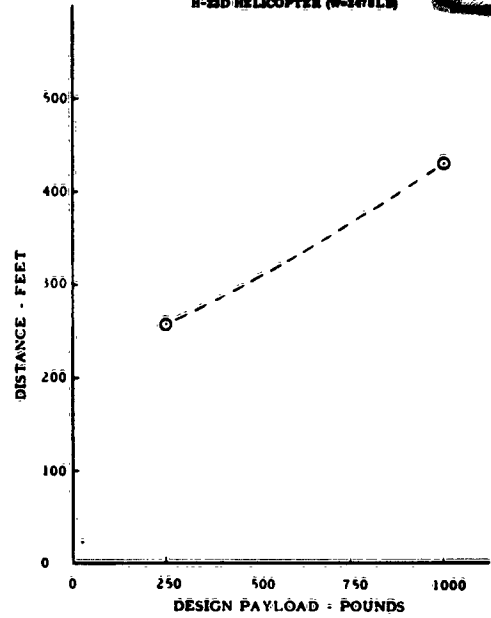

Figure 3

**TAKE-OFF DISTANCE VS
GLIDER DESIGN PAYLOAD
SEA LEVEL STD. DAY
H-24A HELICOPTER (W-6700 LB)**

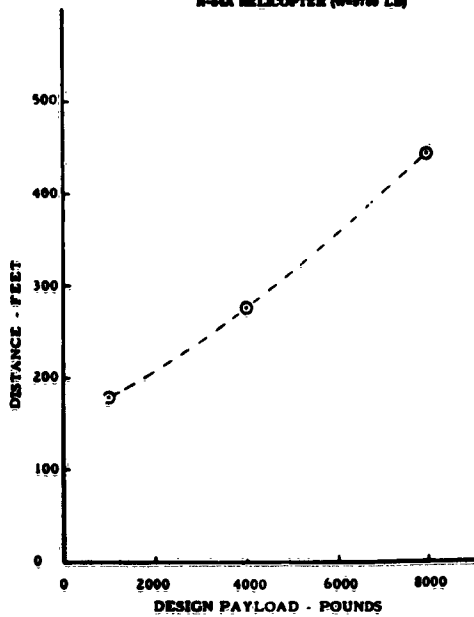

Figure 5

**LANDING DISTANCE VS
GLIDER DESIGN PAYLOAD
SEA LEVEL STD. DAY**

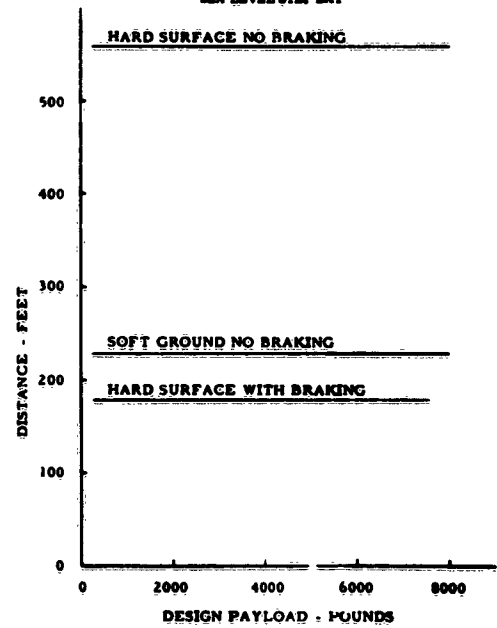

Figure 6

1

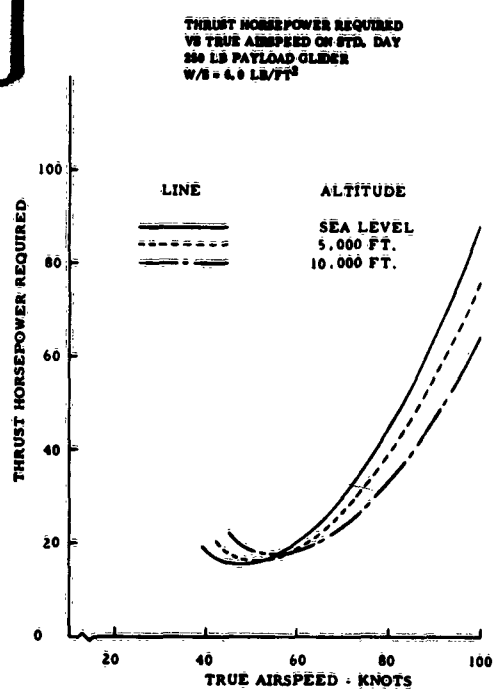

Figure 7

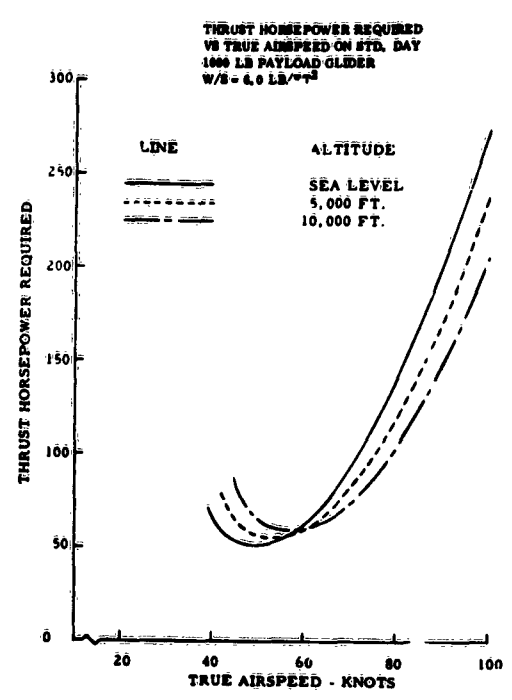

Figure 8

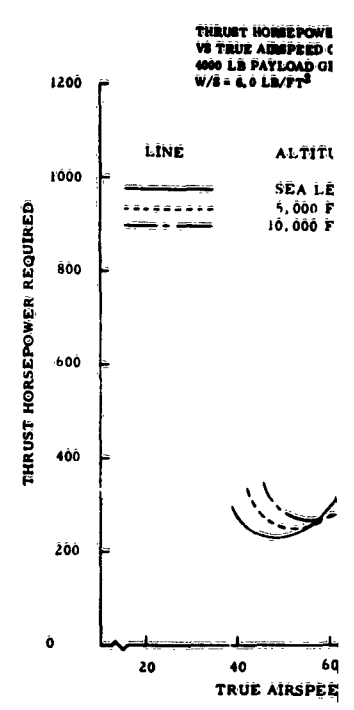

Figure 9

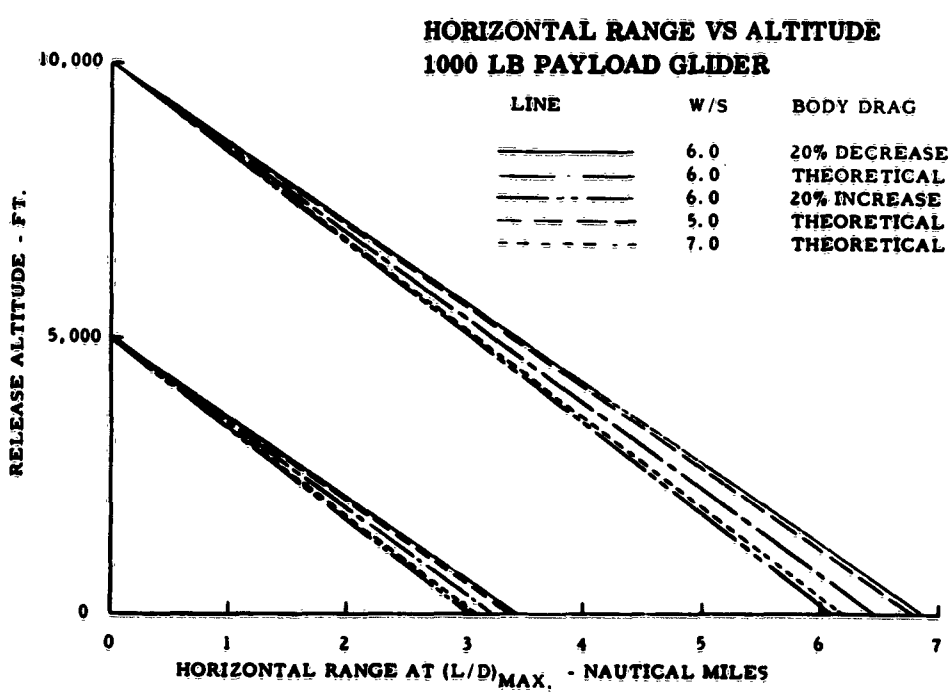
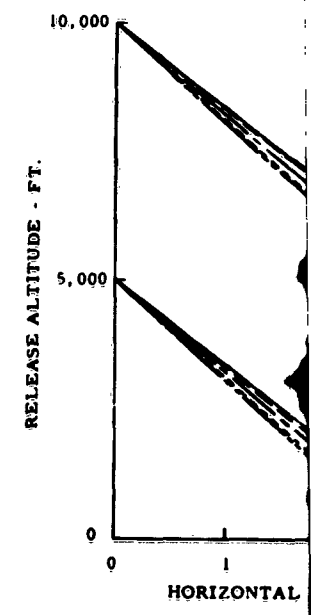

Figure 12



THRUST HORSEPOWER REQUIRED
ON STD. DAY
GLIDER

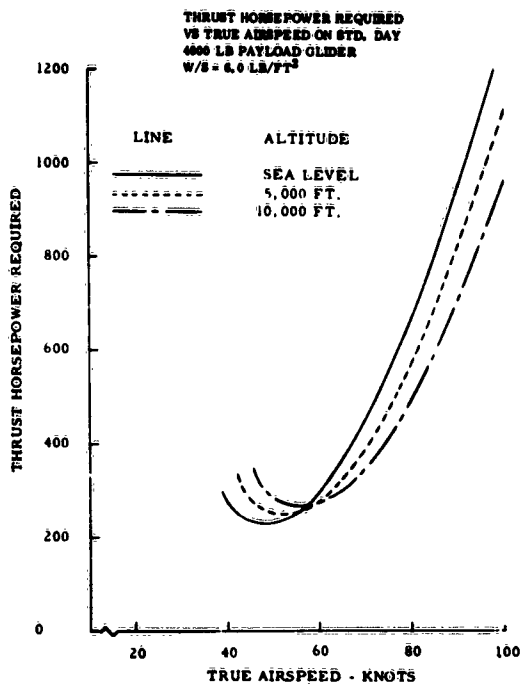
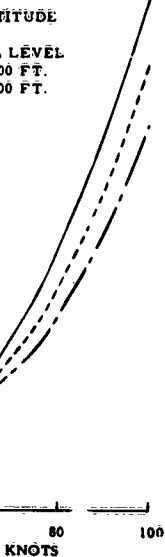

Figure 9

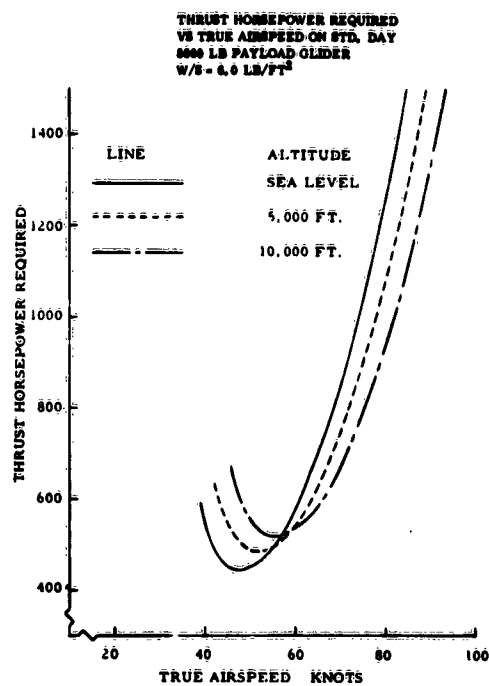
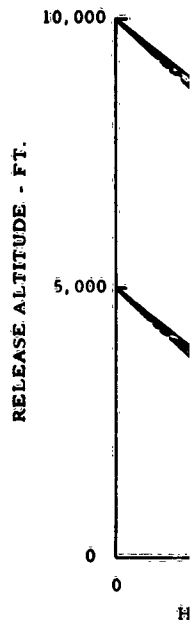

Figure 10



**HORIZONTAL RANGE VS ALTITUDE
4000 LB PAYLOAD GLIDER**

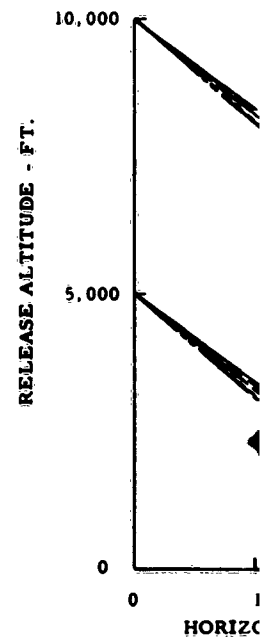
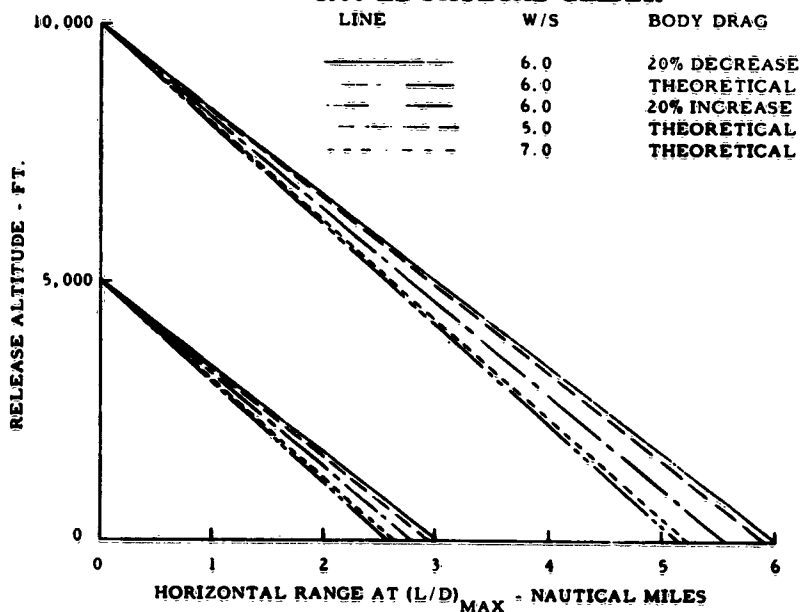

Figure 13



**THRUST HORSEPOWER REQUIRED
VS TRUE AIRSPEED ON STD. DAY
8000 LB PAYLOAD GLIDER
W/S - 6.0 LB/FT²**

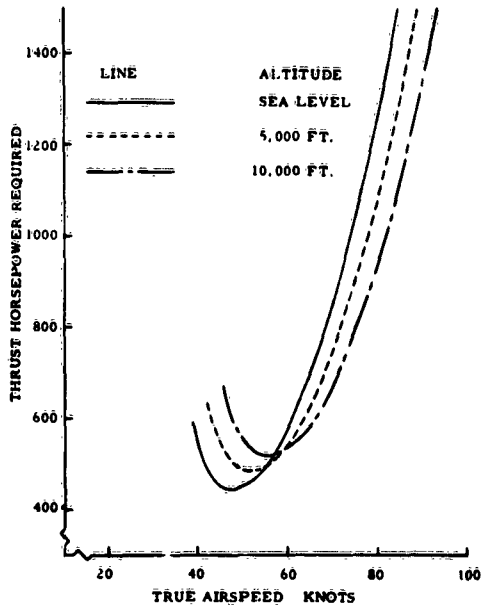

Figure 10

**HORIZONTAL RANGE VS ALTITUDE
250 LB PAYLOAD GLIDER**

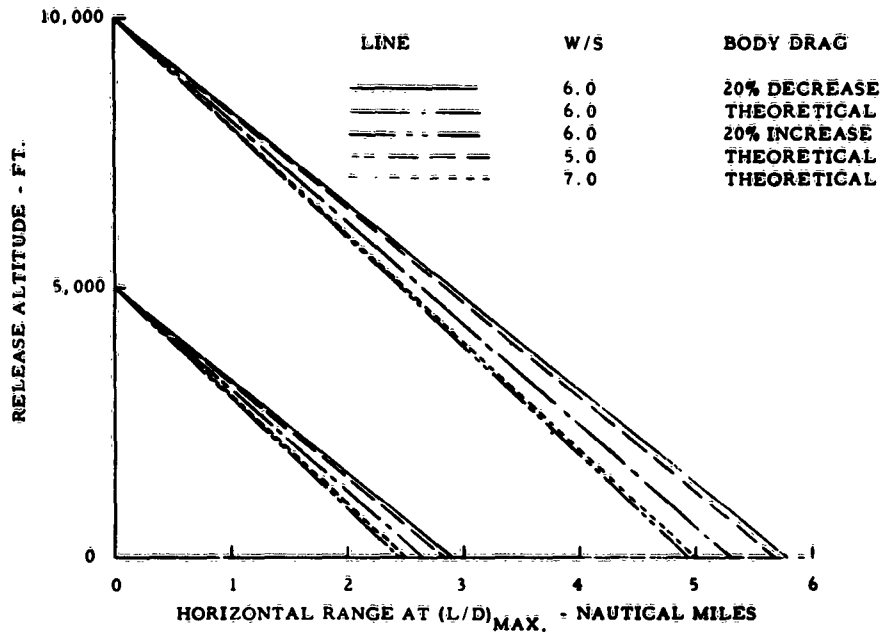
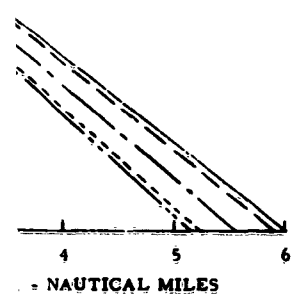

Figure 11

**RANGE VS ALTITUDE
LOAD GLIDER**

W/S	BODY DRAG
6.0	20% DECREASE
6.0	THEORETICAL
6.0	20% INCREASE
5.0	THEORETICAL
7.0	THEORETICAL



**HORIZONTAL RANGE VS ALTITUDE
8000 LB PAYLOAD GLIDER**

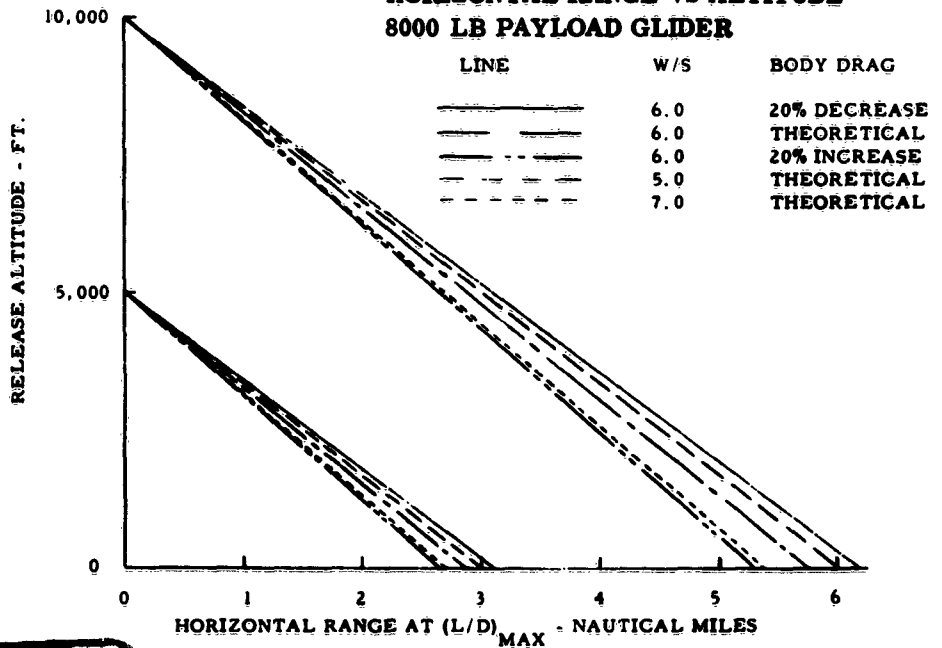

Figure 14

3

The rate of climb data for best climb speeds are presented as a function of altitude in Figures 22, 23 and 24. The climb performance is based on the use of maximum normal power.

Sea level, glider mission profiles are given for the three helicopters in Figures 25, 26, and 27. The mission cruise speeds are those for 99% maximum range. The fuel required for warm-up and take-off is assumed to be equivalent to that required for five minutes of normal power at sea level. The reserves are considered to be 10% of total useable fuel.

The effect of cruise altitude on mission radius can be seen from a comparison of Figures 25, 28 and 29, which apply principally to the Hiller H-23D. Since the altitude of this helicopter does not have a significantly large effect on range, its selection may be based on tactical strategy, terrain, or weather. The effect of altitude on the other helicopter missions is included in Reference 3. Of those investigated, the 5,000 ft. altitude indicated the greatest range for the H-34A, and the 10,000 ft. altitude appeared desirable for the HU-1B.

Fixed Wing Aircraft - Towed Glider Performance

The fixed wing tow vehicle considered is the L-20A De Havilland Beaver. A take-off gross weight of 4,200 lbs. was used for all calculations. This weight is the basic mission take-off weight given in Reference 2, decreased by the internal payload and increased by the addition of a co-pilot.

The rate of climb vs. true airspeed of the L-20A and L-20A with towed gliders is shown in Figures 15, 16 and 17.

A synopsis of L-20A performance with towed gliders is given in the mission profiles of Figures 18 through 21. From the total of 570 lbs. of fuel available, 20 lbs. were used for warm-up and take-off ground run. The reserves include fuel for 20 minutes long range cruise at sea level and 5% allowance for variation in individual engine fuel consumption.

Considering mission radius, it is advisable to use a towed wing loading greater than 6.0 lbs/ft.² with the L-20A tow vehicle. It is to be noted that as the wing loading is increased on the towed gliders, both take-off and landing speeds also increase.

Free Flight Performance

A lift and drag analysis of each different payload configuration was made. The force characteristics of the Flexible Wing were obtained from unpublished NASA wind tunnel data. The drag of the remaining components was built up in the conventional theoretical manner with extensive use of Reference 1. Performance analysis was made for three wing loadings and three body drag coefficients. Unless otherwise indicated, results presented are for a wing loading of 6.0 lbs/ft.² at the theoretical, or median, body drag coefficient.

Thrust horsepower required vs. true airspeed for each payload vehicle is presented in Figures 1 through 4. Minimum horsepower required to tow the glider at 50 to 60 knots. The tow airspeeds for the combination of tow vehicle and glider are generally higher, since power requirements of the combination must be considered.

Maximum lift/drag ratios average 3.5 and occur at a true airspeed of approximately 55 knots at sea level. These relatively low lift/drag ratios lead to high rates of sink. For example, during a maximum lift/drag ratio glide at sea level, the rate of sink is approximately 1500 ft/min. A synopsis of free glide performance is presented in the horizontal range vs. altitude plots shown in Figures 5 through 8. A 20% increase or decrease in body drag and a variation of 1.0 lb/ft.² in wing loading has minor effect on the overall flight performance. Drag should be kept to a minimum, and wing loading may be altered as necessary to match flight airspeeds of towing vehicle and the glider.

Stability and Control

The analysis of the four basic configurations of the cargo gliders showed the possible requirement for increased longitudinal and directional stability for the established static trim and dynamic stability of the 250 pound glider. The 1,000, 4,000 and 8,000 pound payload gliders are within the established margins. Improvements in the stability of the 250 pound payload version may be made by re-positioning the wing or by the addition of vertical fins.

In order to assure convergence of both dutch roll and spiral mode, a precise ratio of directional stability/effective dihedral must be maintained. A ratio of $-.25$ for $C_{\eta_{\beta}} / C_{l_{\beta}}$ is optimum for all configurations during the cruise mode. The ratio for climb and landing flare modes will be a lesser value, since the products of inertia, I_{xz} , become greater.

1

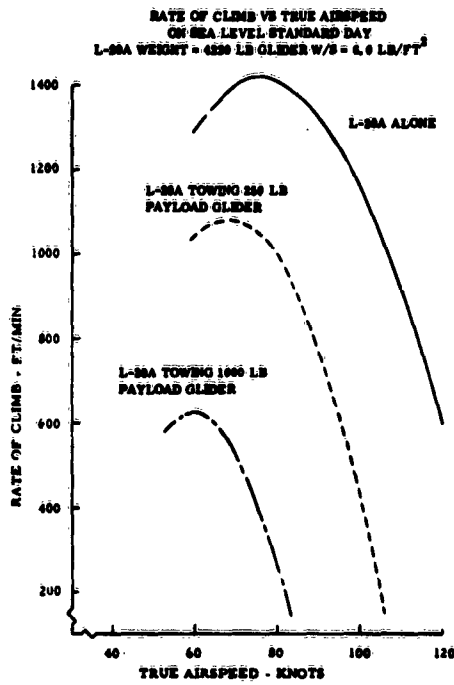

Figure 15

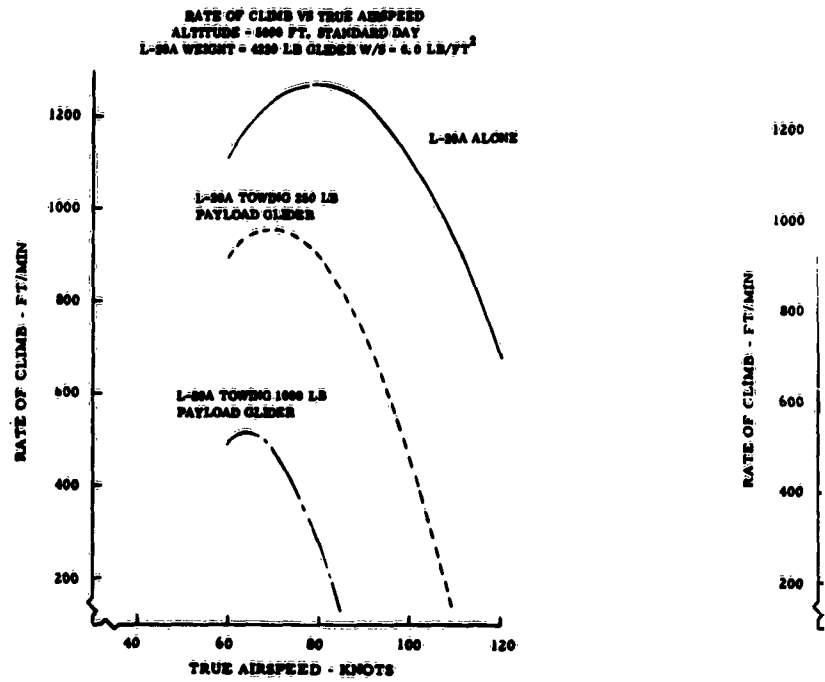

Figure 16

L-20A MISSION PROFILE

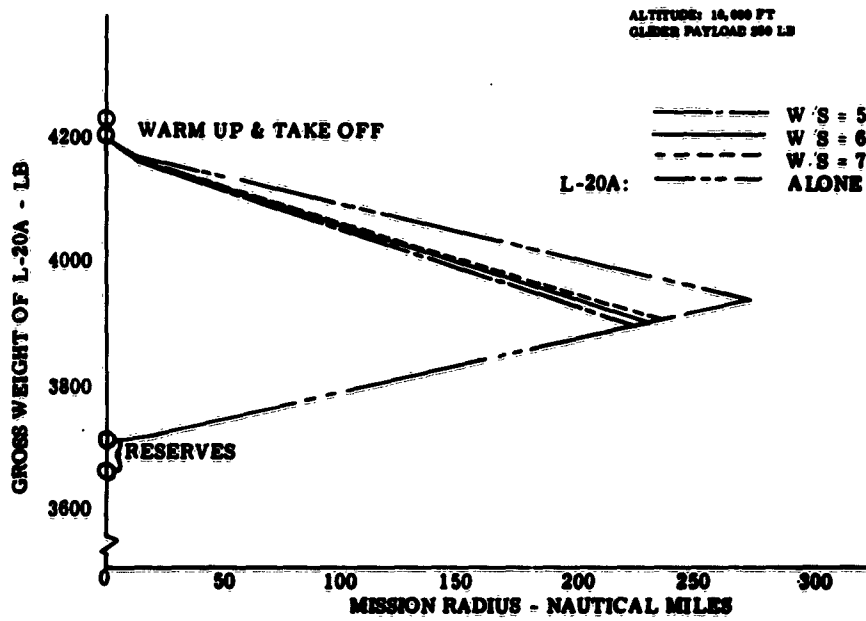
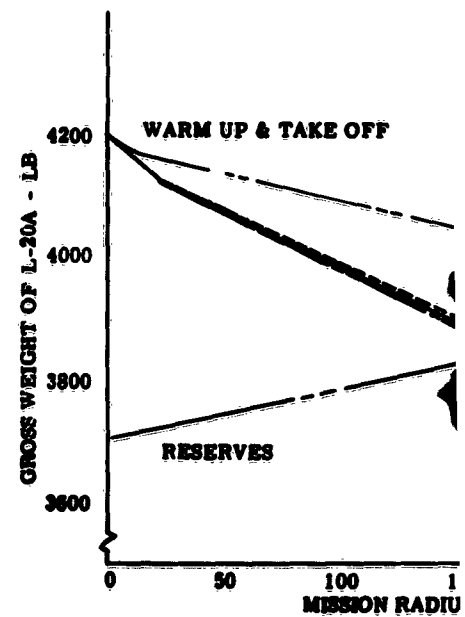

Figure 19



RATE OF CLIMB VS TRUE AIRSPEED
 ALTITUDE - 10,000 FT. STANDARD DAY
 L-20A WEIGHT - 4200 LB GLIDER W/S = 4.0 LB/FT²

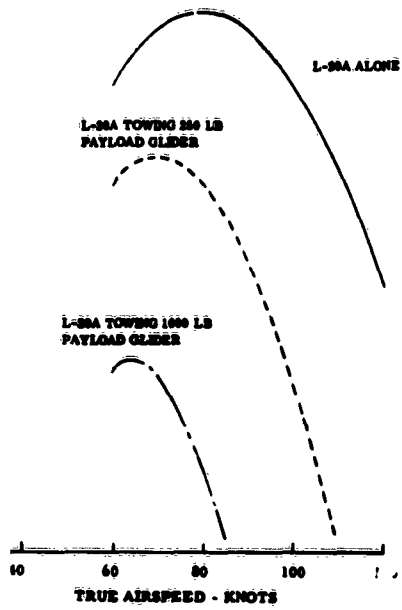

Figure 16

RATE OF CLIMB VS TRUE AIRSPEED
 ALTITUDE - 10,000 FT. STANDARD DAY
 L-20A WEIGHT - 4200 LB GLIDER W/S = 4.0 LB/FT²

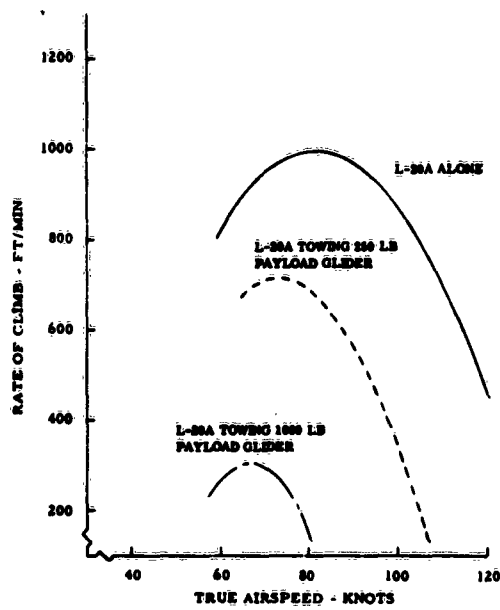
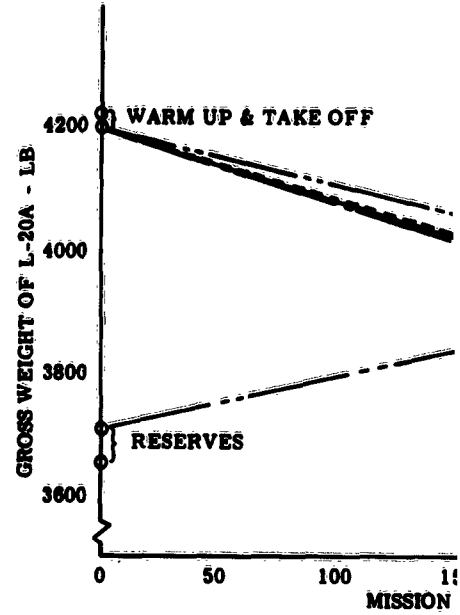

Figure 17



L-20A MISSION PROFILE

ALTITUDE: 10,000 FT
 GLIDER PAYLOAD 1,000 LB

W/S = 5.0 LB/FT²
 W/S = 6.0 LB/FT²
 W/S = 7.0 LB/FT²
 ALONE

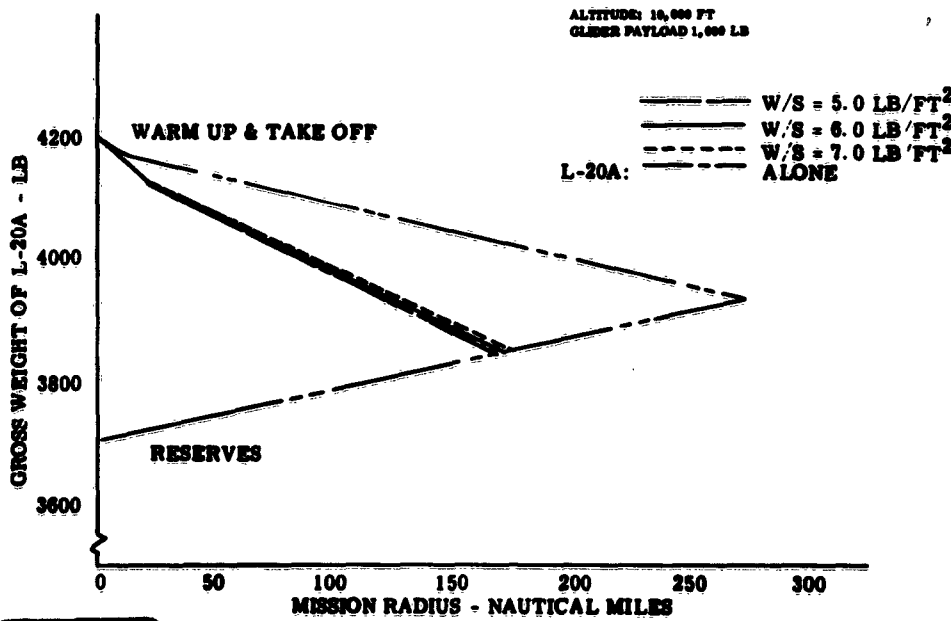
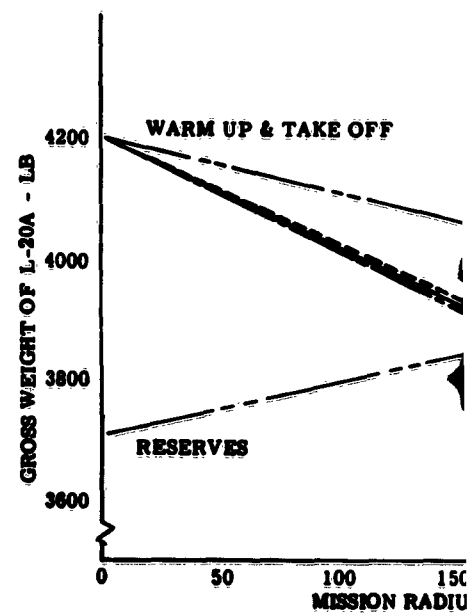

Figure 20



RATE OF CLIMB VS TRUE AIRSPEED
 ALTITUDE = 10,000 FT STANDARD DAY
 L-20A WEIGHT = 4200 LB GLIDER W/S = 6.0 LB/FT²

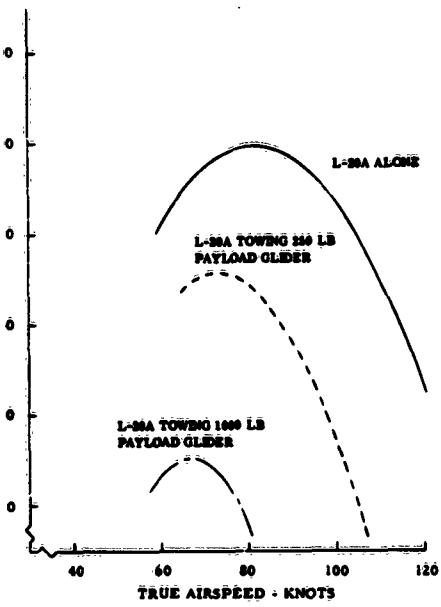

Figure 17

L-20A MISSION PROFILE

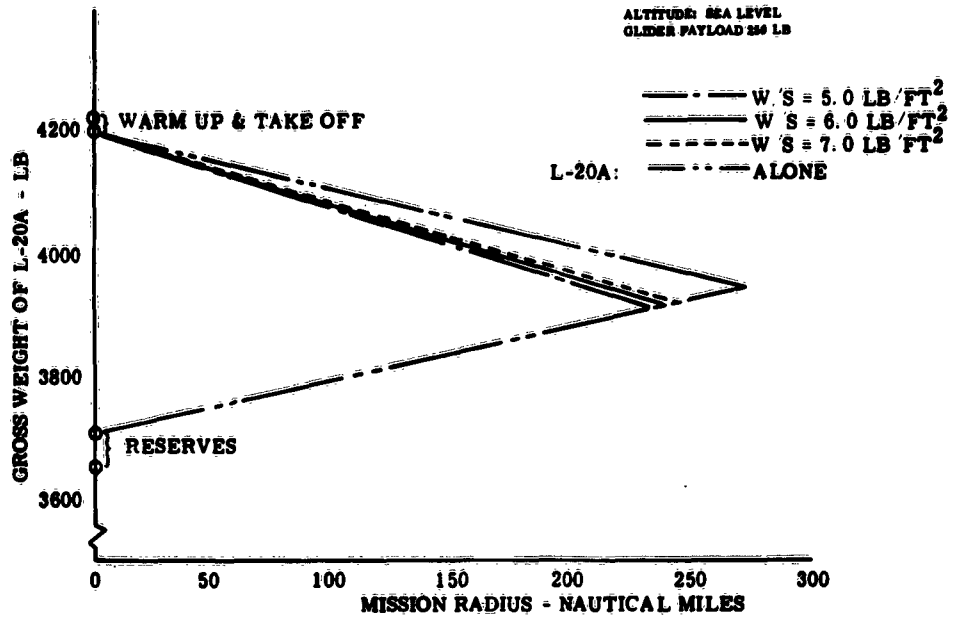

Figure 18

L-20A MISSION PROFILE

ALTITUDE: 10,000 FT
 GLIDER PAYLOAD 1,000 LB

W/S = 5.0 LB/FT²
 W/S = 6.0 LB/FT²
 W/S = 7.0 LB/FT²
 L-20A: ALONE

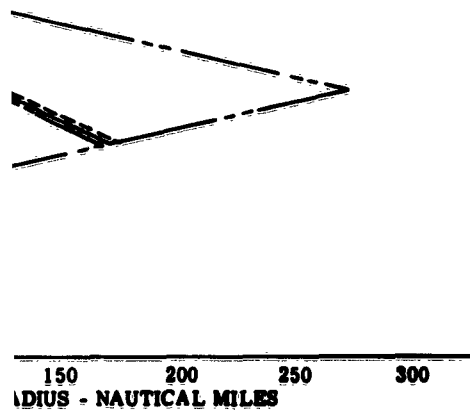

Figure 20

L-20A MISSION PROFILE

ALTITUDE: SEA LEVEL
 GLIDER PAYLOAD 1,000 LB

W/S = 5.0 LB/FT²
 W/S = 6.0 LB/FT²
 W/S = 7.0 LB/FT²
 L-20A: ALONE

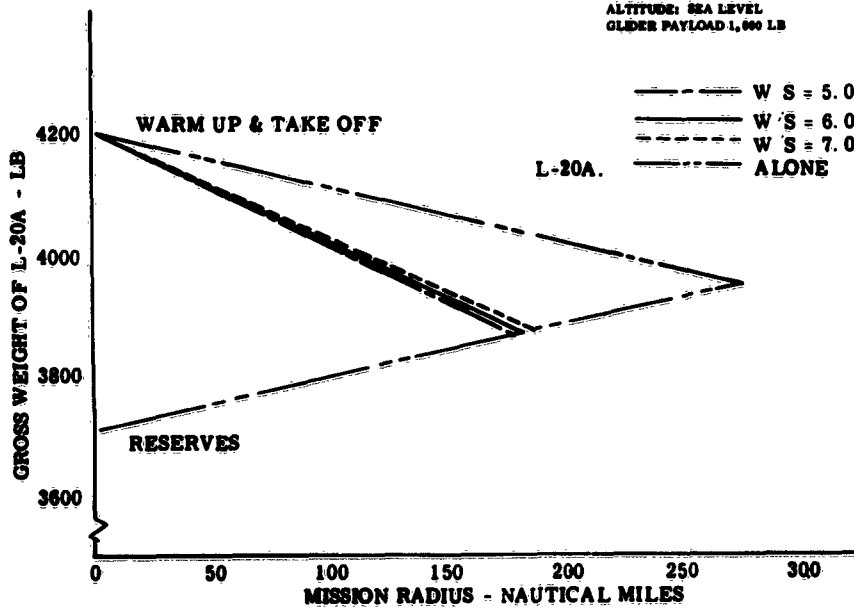
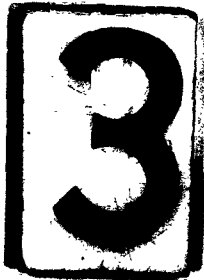

Figure 21



1

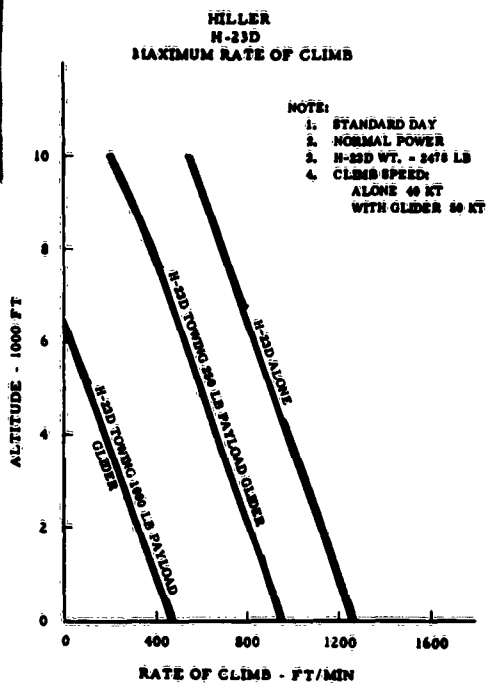

Figure 22

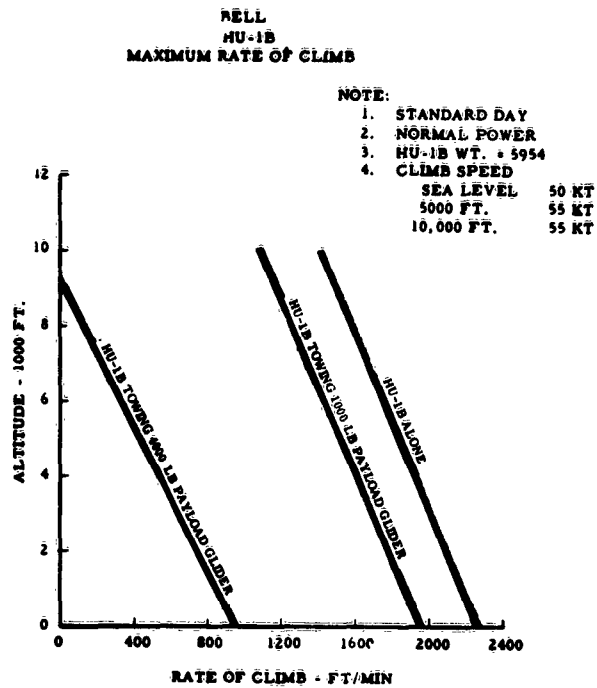

Figure 23

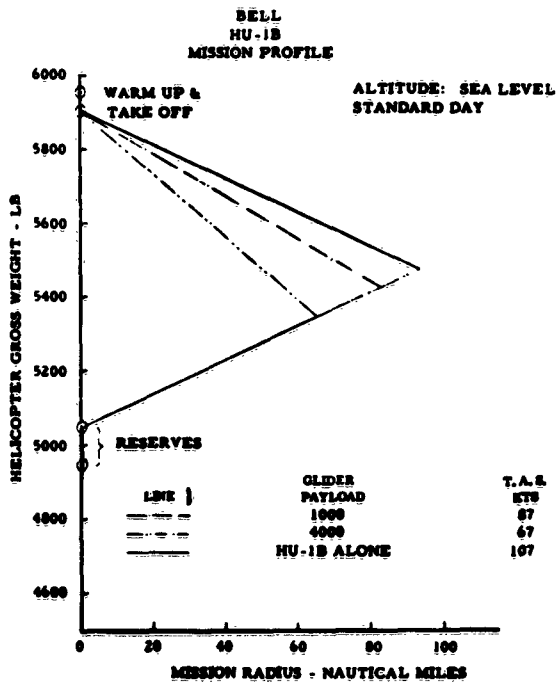

Figure 26

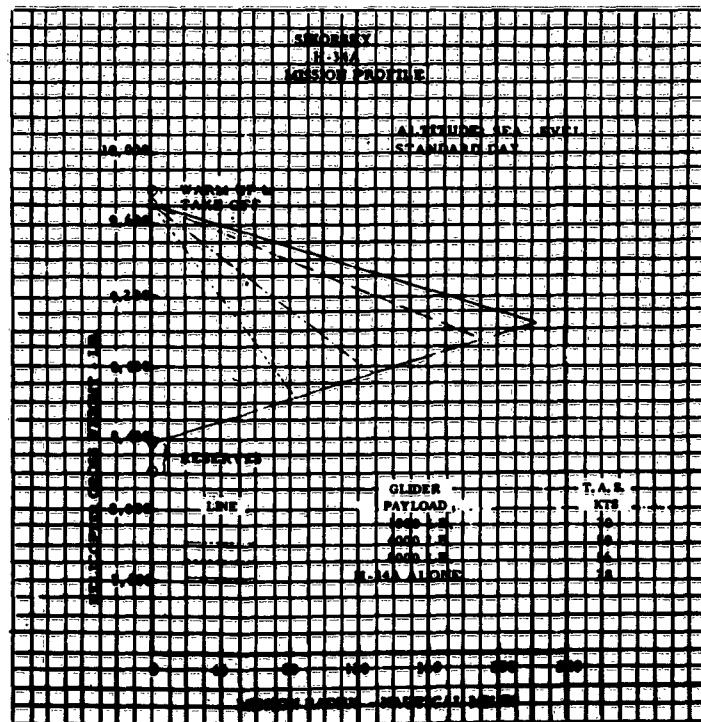

Figure 27



**MILLER
HU-1B
MAXIMUM RATE OF CLIMB**

- NOTE:
1. STANDARD DAY
 2. NORMAL POWER
 3. HU-1B WT. = 5954
 4. CLIMB SPEED
- | | |
|------------|-------|
| SEA LEVEL | 50 KT |
| 5000 FT. | 55 KT |
| 10,000 FT. | 55 KT |

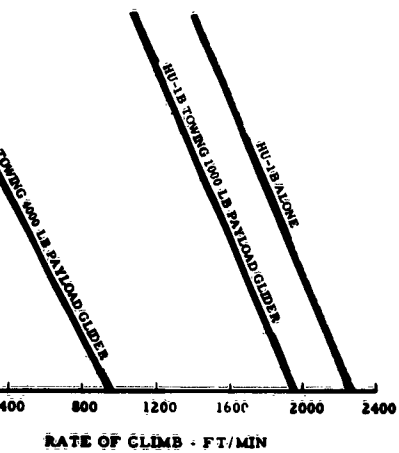

Figure 23

**SIKORSKY
H-34A
MAXIMUM RATE OF CLIMB**

- NOTE:
1. STANDARD DAY
 2. NORMAL POWER
 3. H-34A WT. = 9789 LB.
 4. CLIMB SPEED
- | | |
|-----------|-------|
| SEA LEVEL | 50 KT |
| 5000 FT. | 55 KT |
| 10000 FT. | 60 KT |

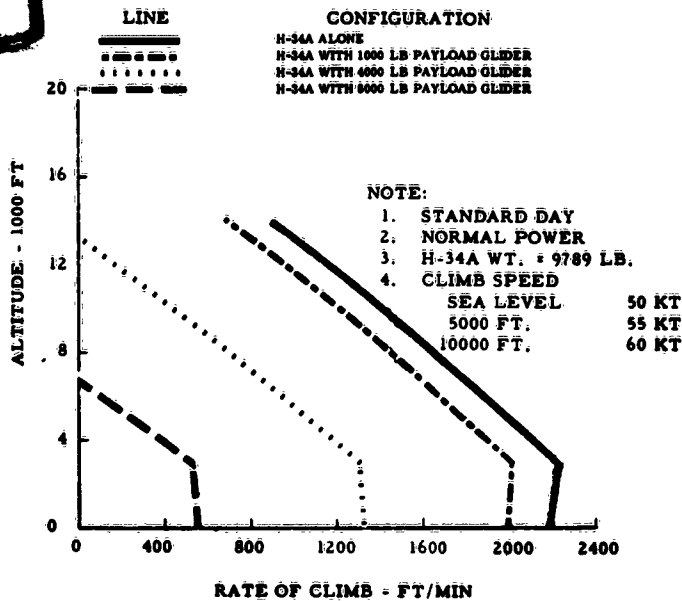
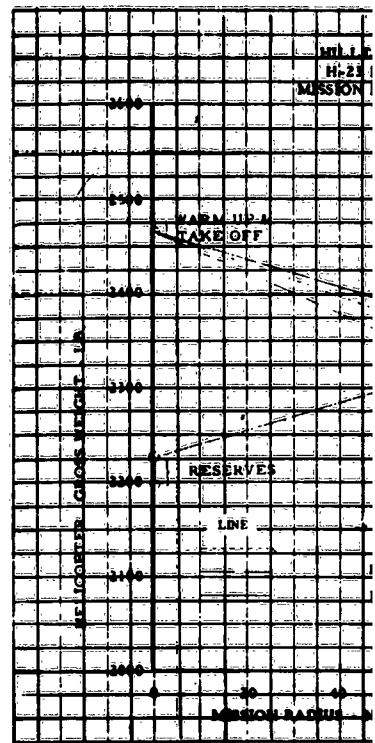

Figure 24



Fig

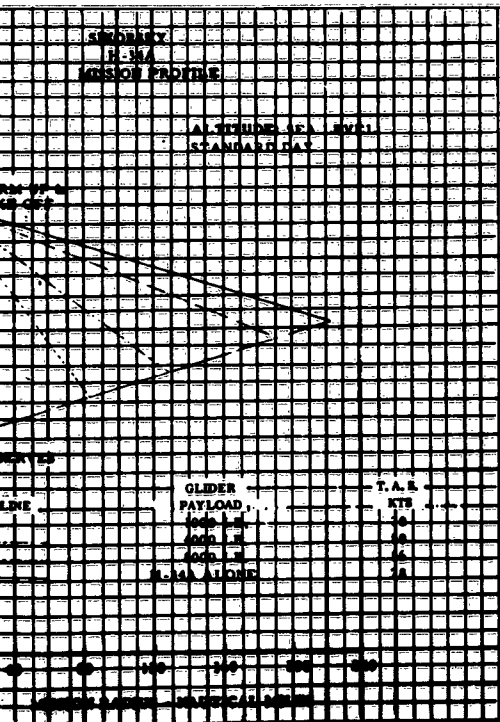

Figure 27

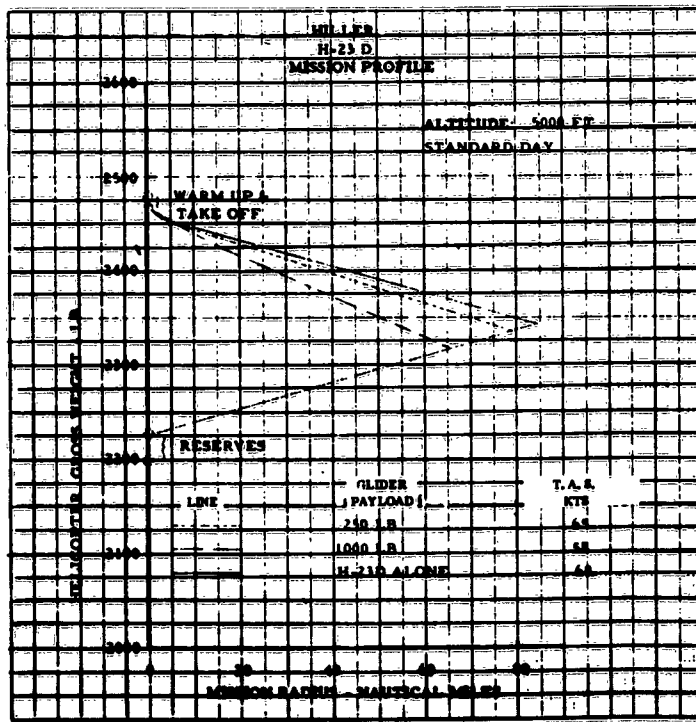
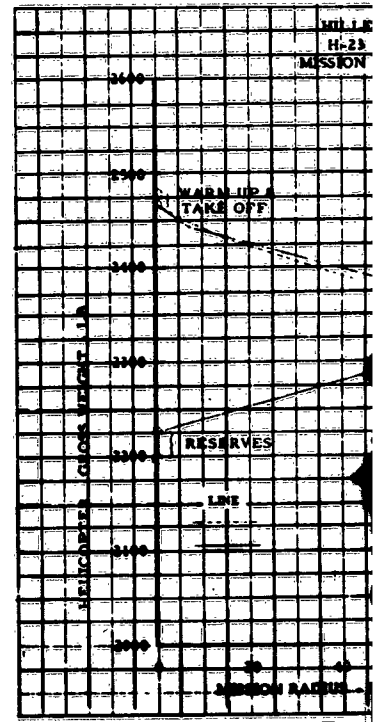

Figure 28



Fig

SIKORSKY
H-34A
MAXIMUM RATE OF CLIMB

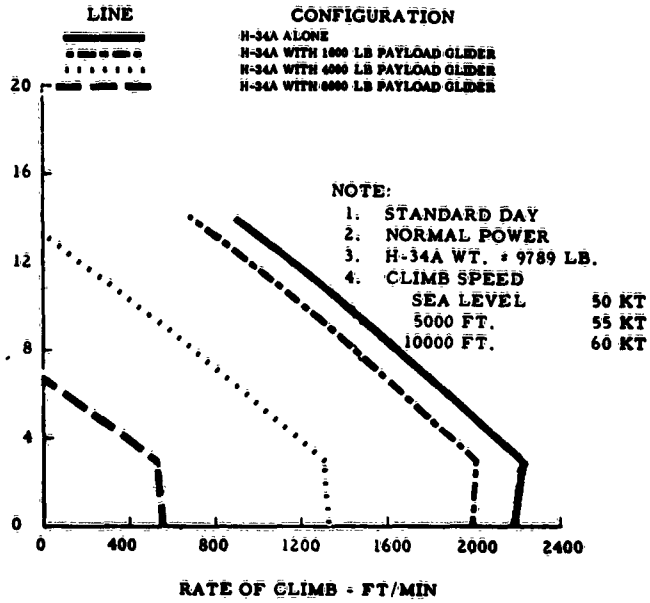

Figure 24

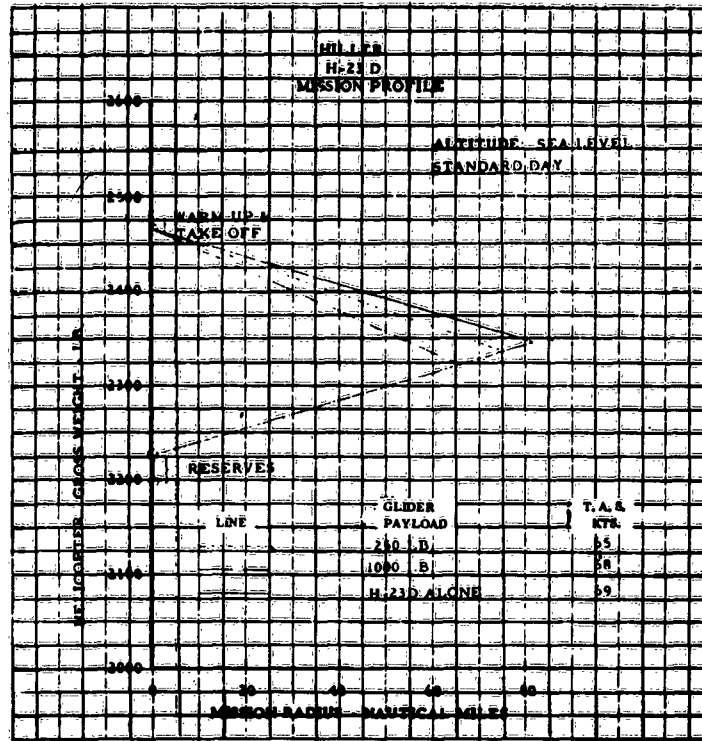

Figure 25

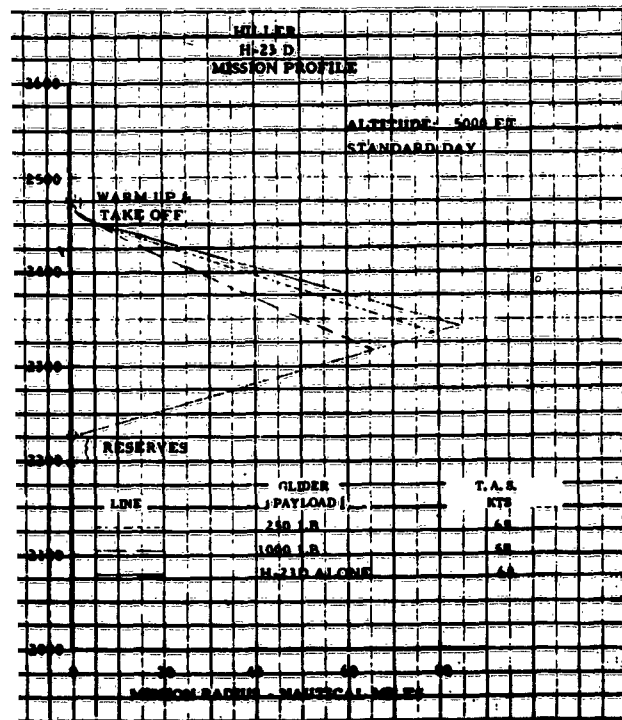

Figure 28

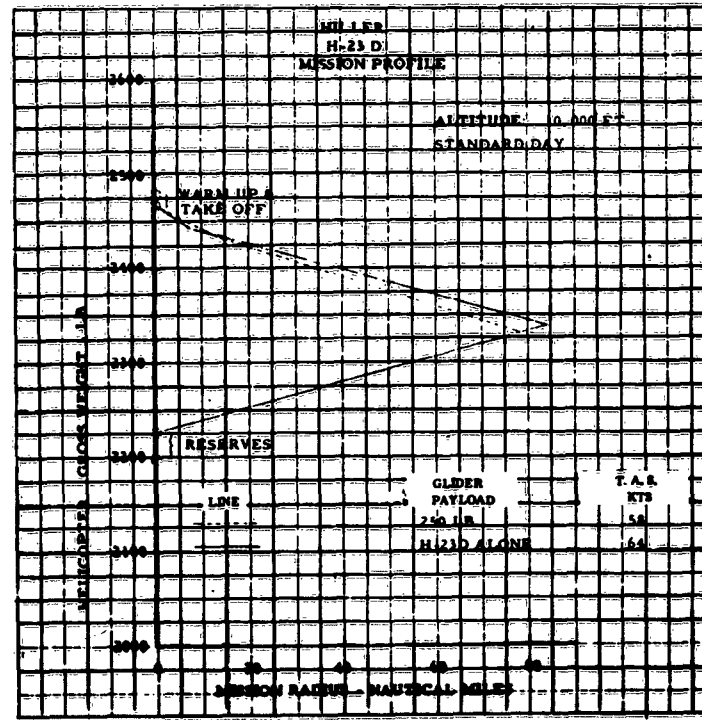

Figure 29



The increase in the products of inertia (while $C_{\eta\beta} / C_{l\beta}$ is becoming smaller) is in the direction of oscillatory divergence; consequently, the criterion of maximum possible directional stability at cruise will guard against dutch roll divergence for other lift coefficients. Sufficient directional stability must be provided to offset the adverse I_{xz} values arising from inadequate balance control when cargo loading during field operations.

The free flight longitudinal static stability is adequate for the 1,000, 4,000 and 8,000 pound payload configurations, but the 250 pound configuration is statically unstable, which again, may be "fixed" by repositioning the wing to a point further aft, or the addition of vertical fins. Longitudinal control and direction is by C. G. shift from wing deflection. A roll control mechanism, using the aerodynamic compressive loads of the wing, is feasible in order to reduce the control force encountered in the C. G. shift method. The optimum position of the hinge is at 60 percent of the span.

Analysis of lateral directional dynamic stability during tow specified a minimum length of the towline 4.7 times the keel length of the wing on the towed vehicle. This assures convergence of the oscillations resulting from a disturbance. The towing bridle of the towed vehicle is attached at the nose of the body and on the keel of the wing. The attach points of the bridle on the wing keel may be derived from the equations, $\frac{X}{C_r} = .094$ and $\frac{Z}{C_r} = .045$. The bridle length is

92 percent of the keel length of the wing. The dynamic stability of the H-34 helicopter in combination with the 8,000 pound configuration was analyzed by studying the frequency of the individual configurations for possible coupling modes. The response of the helicopter at cruise is deadbeat, while the damped natural frequency of the glider on tow is 7.9 rad/sec. This eliminates dynamic instability due to resonance in the system.

**GLIDER
TRIM REQUIREMENTS**

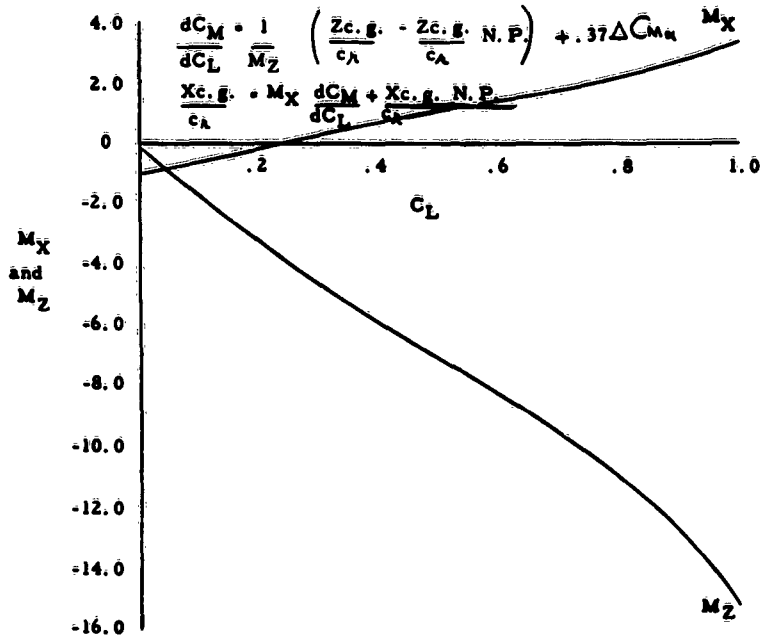

Figure 30

LONGITUDINAL GEOMETRY

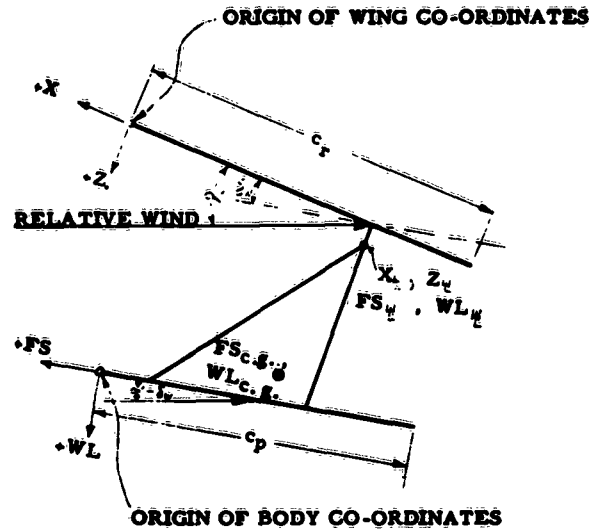

Figure 31

**GLIDER
TRIM NEUTRAL POINTS**

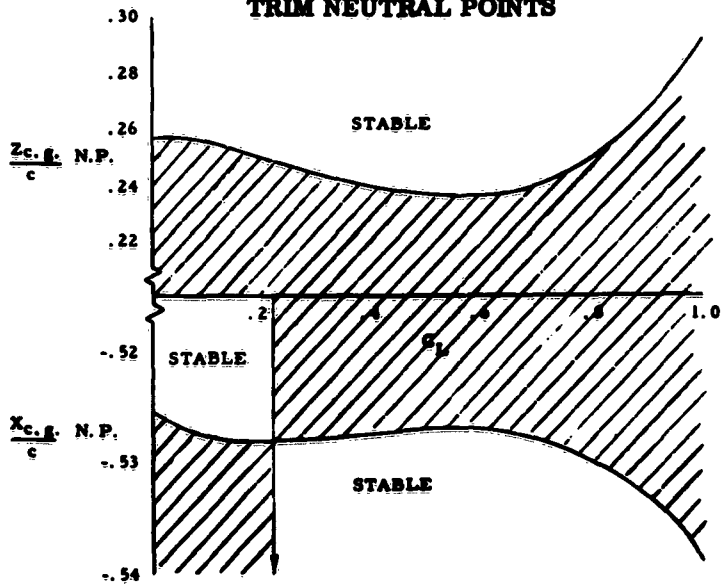

Figure 32

**CENTER OF GRAVITY VARIATION
WITH
WING ANGLE**

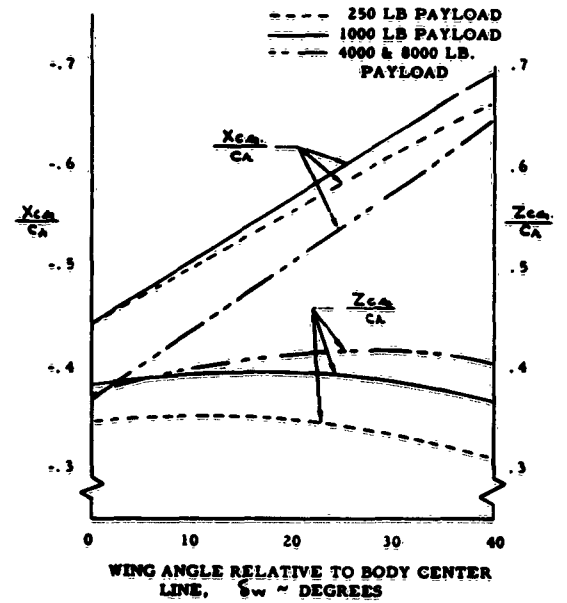

Figure 33

DYNAMIC STABILITY DURING TOW
EFFECTS OF ATTACH POINTS

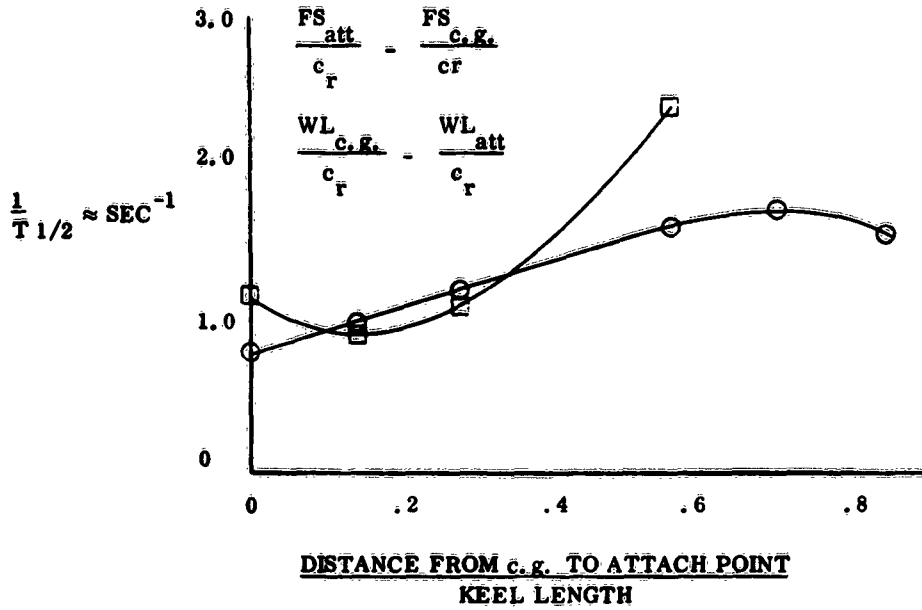

Figure 34

WING SWEEPBACK ANGLE
VS.
WING LATERAL DEFLECTION

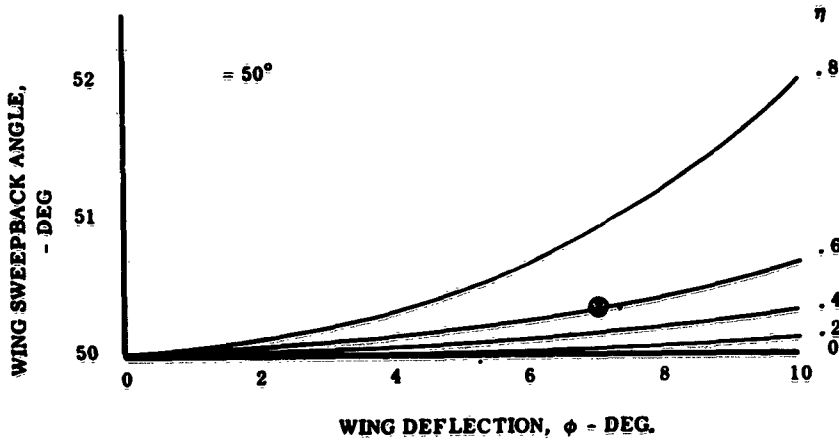
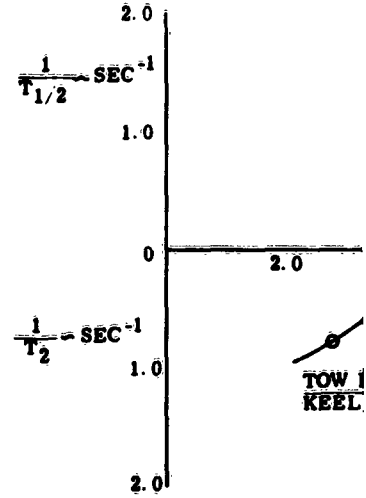
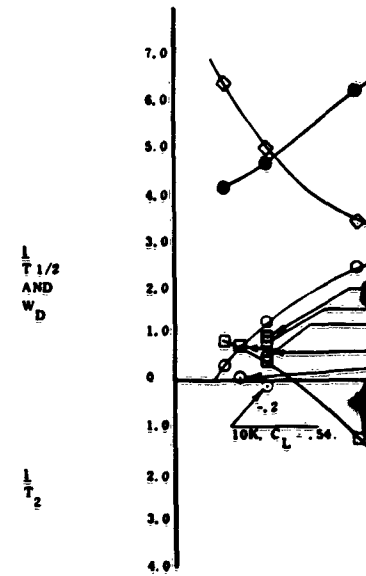

Figure 36

Dynamic Stabil
Tow Line Leng



DYNAMIC STABILITY
VARIATION WITH DIRECTION



Fig



**DYNAMIC STABILITY DURING TOW
EFFECTS OF ATTACH POINTS**

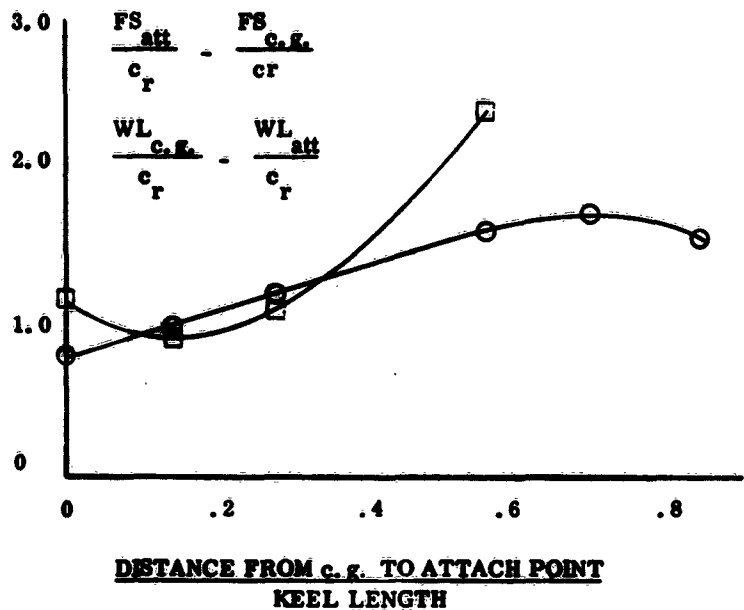

Figure 34

**WING SWEEPBACK ANGLE
VS.
WING LATERAL DEFLECTION**

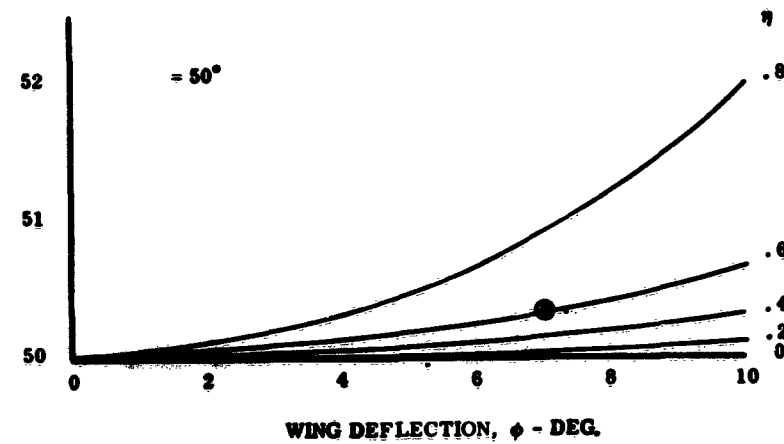

Figure 36

**Dynamic Stability During Tow Effect of
Tow Line Length**

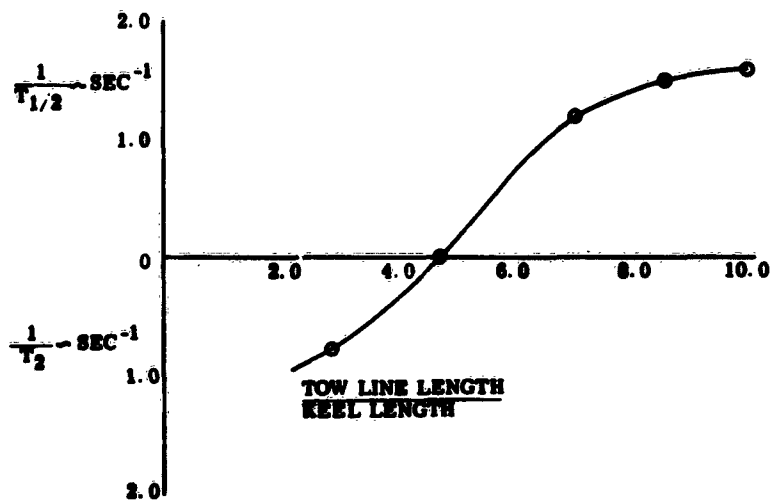

Figure 35

**DYNAMIC STABILITY
VARIATION WITH DIRECTIONAL STABILITY**

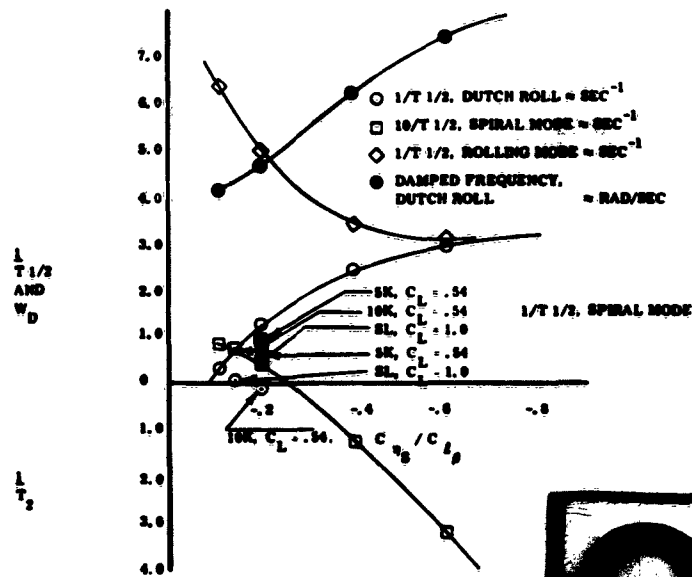

Figure 37



Tow Aircraft Modifications

The Army L-20 airplane, designated tow airplane for the 250 and 1,000 pound payload Flexible Wing gliders, will require few modifications for towing. A bracket must be added to the tail wheel bulkhead for attachment of the tow cable. A 1/16 in diameter steel cable provides the pilot a manual release system. A switch and wire will provide an electrical system to energize the solenoid to release the glider. Ryan study drawing B-63-0025 shows suggested modifications.

The H-23D helicopter, used to tow the 250 and 1,000 pound payload Flexible Wing gliders, will require modifications as follows: A welded tubular truss consisting of six tubes and a hub will be attached to each side of the fuselage structure. At the focal point of the six tubes, a hook assembly will be attached. The forward tow bridle will fasten to the aircraft at the hook assemblies. A single cable extends from the apex of the helicopter to the apex of the glider bridle. A switch located in the pilot's compartment energizes a solenoid at the glider bridle apex releasing the glider. A pull handle accessible to the pilot releases the tow cable and forward bridle. Ryan study print B-63-0022 shows suggested modifications.

The HU-1A helicopter, will require modifications as follows: A small reinforced door added to each side of the fuselage near the aircraft center of gravity. A bracket and hook assembly is bolted to the structure inside each door. A switch located in the pilot's switch panel energizes a solenoid located at the apex of the glider tow bridle releasing the glider from the tow bridle. The tow bridle and cable are released from the aircraft by means provided at the pilot's station. The hook assembly is spring loaded to return to its original position inside the fuselage when the tow cable is released. Ryan study drawing B-063-0026 shows the suggested modifications.

The H-34 helicopter will require the following modifications. On each side of the fuselage adjacent to the center of gravity, a plate approximately 8" x 28" is riveted to the aircraft structure. A tube, attached by multiple brackets to the plate, supports the release hooks. A bridle attaches to the release hooks and from its apex a cable runs aft to the apex of the glider bridle. A switch located in the pilot's switch panel energizes a solenoid to release the glider. Following release of the glider, the tow aircraft pilot may mechanically release the tow cable and bridle at the release hooks. Ryan study drawing B-063-0028 shows the suggested modifications.

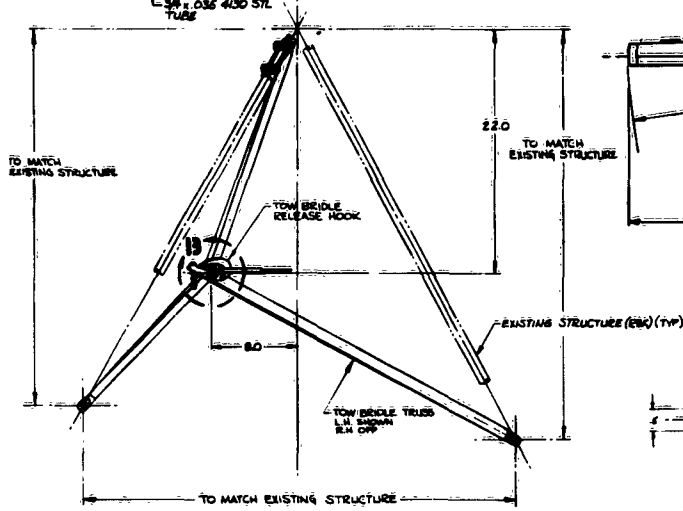
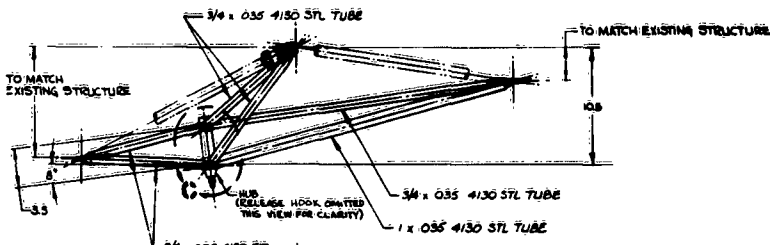

DETAIL A
SCALE: 1/4

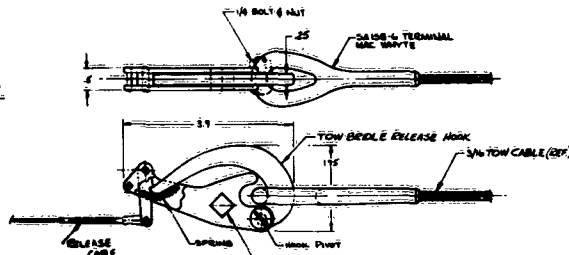
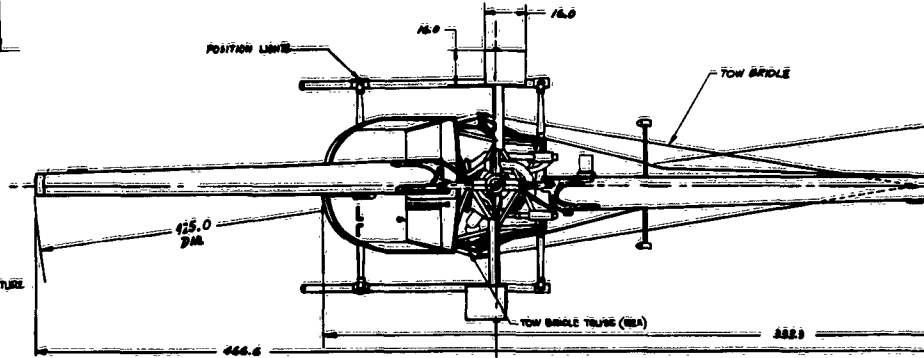

DETAIL B
SCALE: 1/4

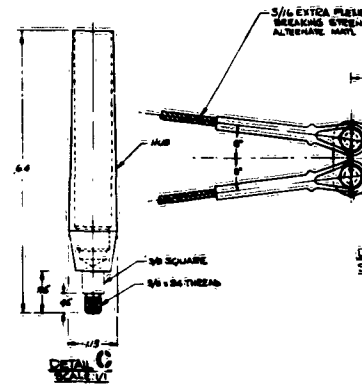

DETAIL C
SCALE: 1/4

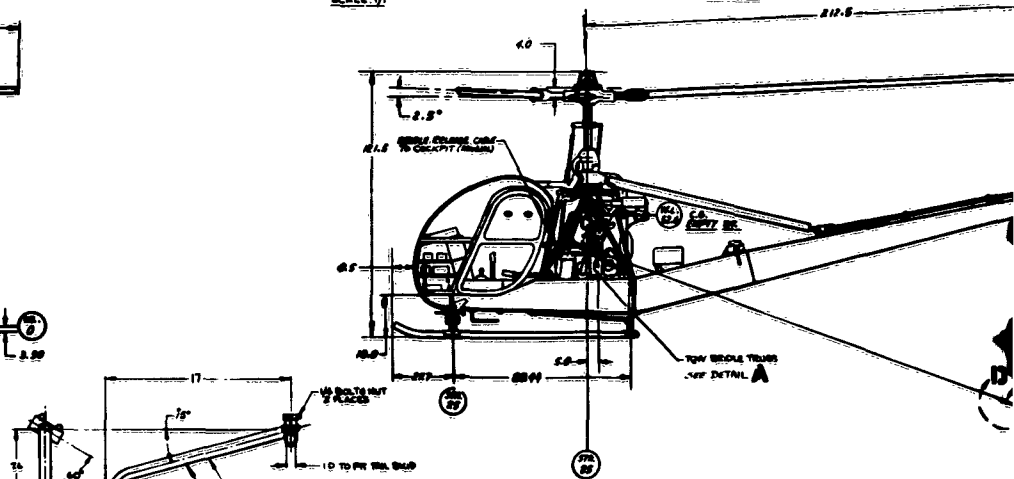
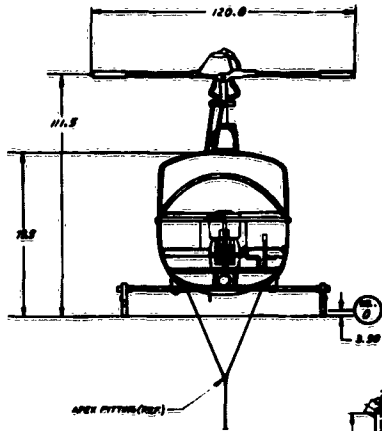

DETAIL D
SCALE: 1/2

Note: Max. Load 1000 Lb. Payload Glider

Dwg. 8 - B063-0022 Study - H-23D Helicopt



1

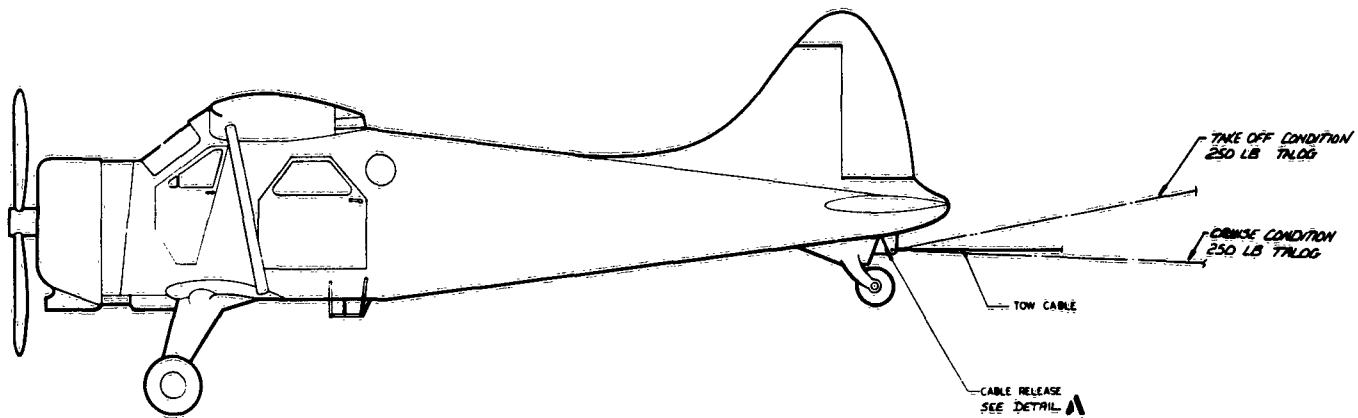
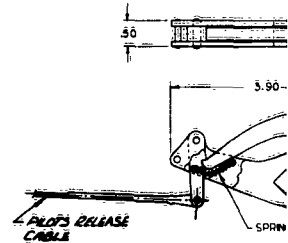
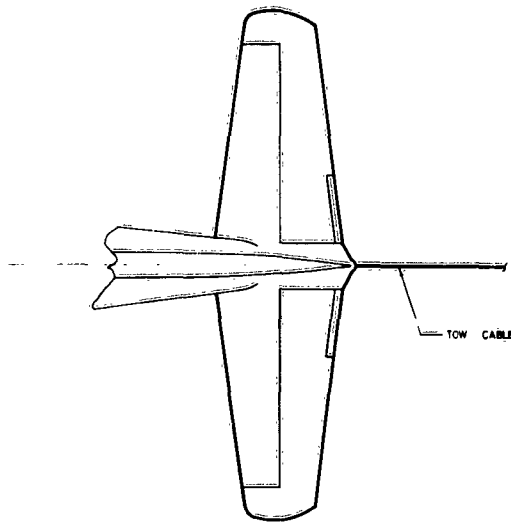

Horizontal Reference Line
Take Off Condition - 250 Lb Glider

Horizontal Reference Line
Cruise Condition - 250 Lb Glider

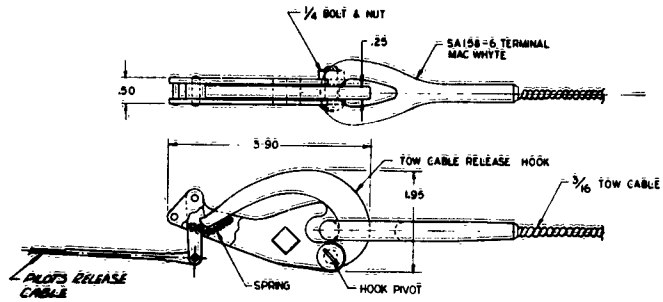
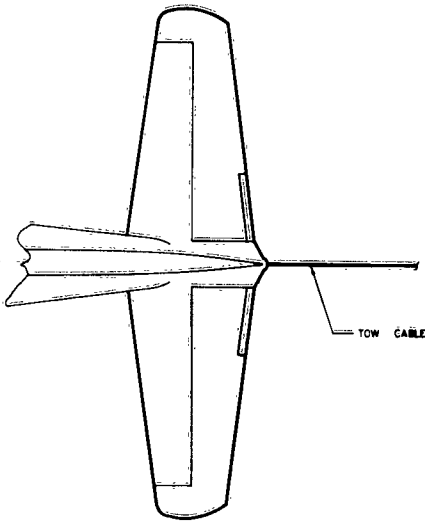

DETAIL A
 SCALE 1/1

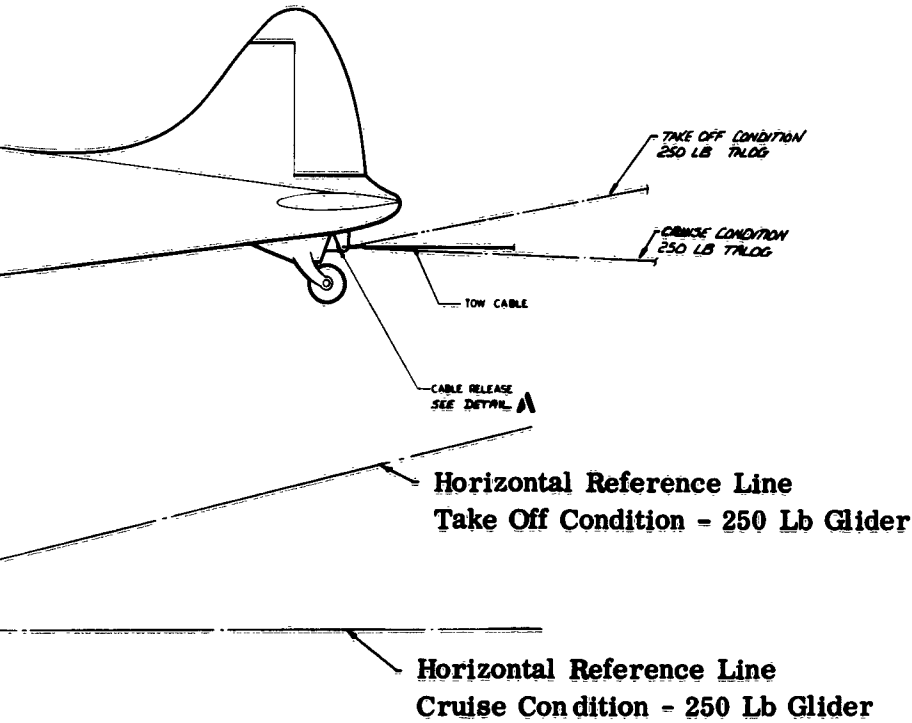

2

Dwg. 9 - B063-0025 Study - L-20 Aircraft Modifications for Towing

1

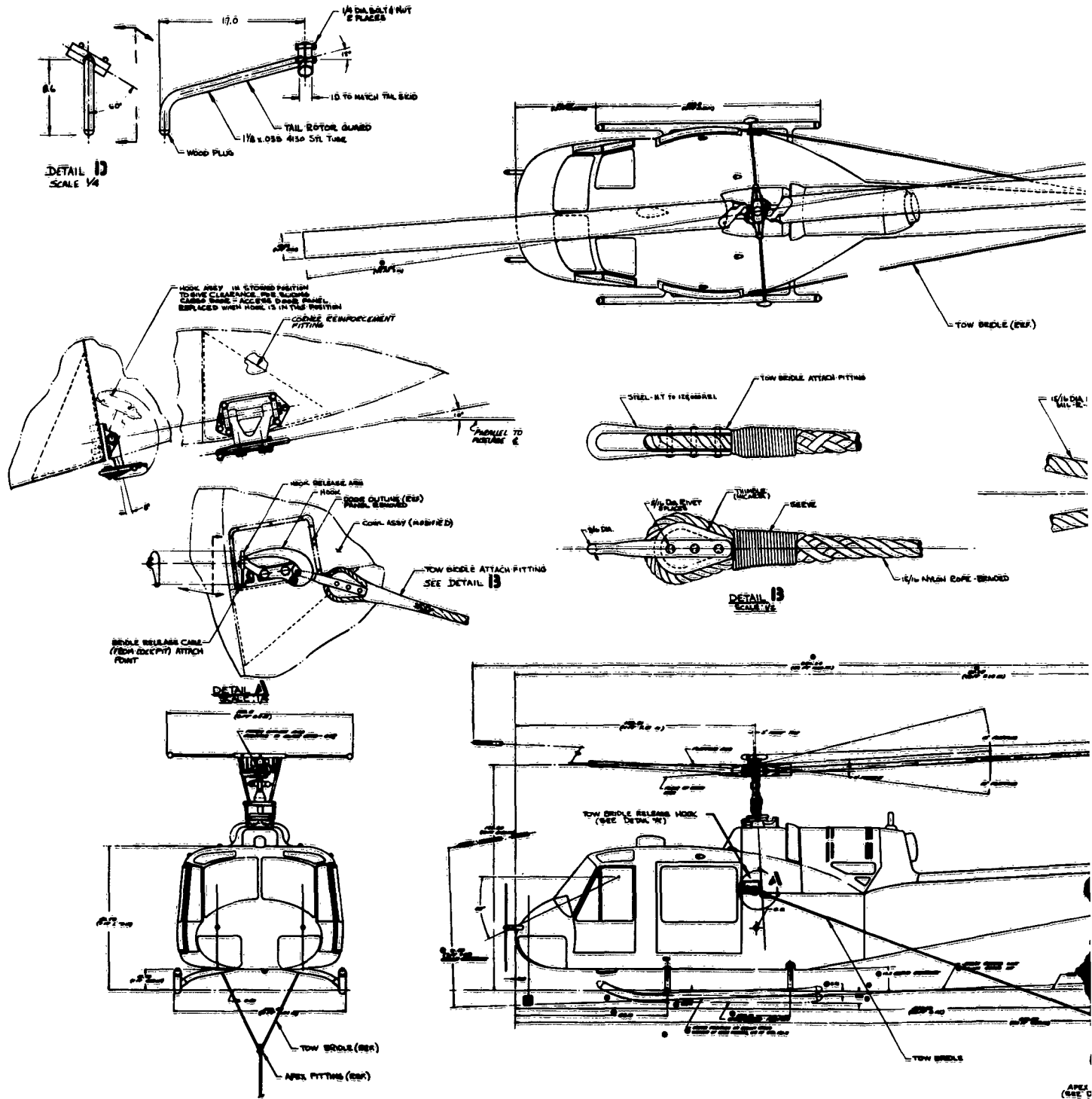

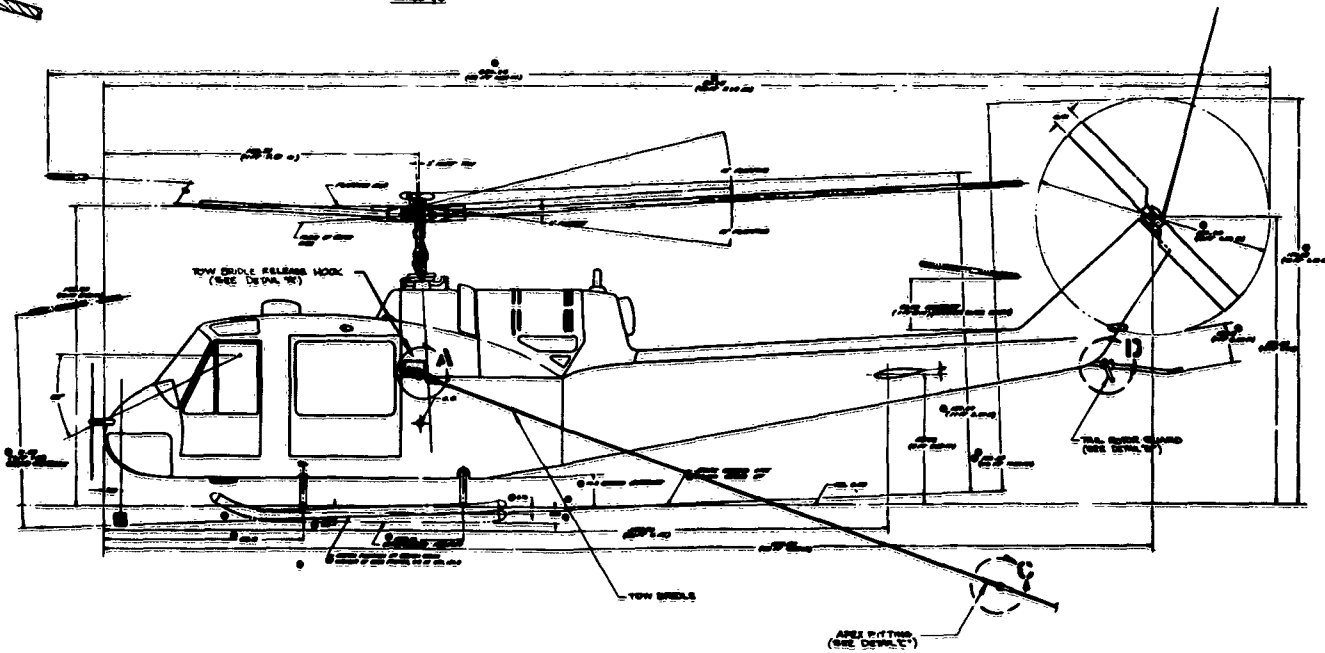
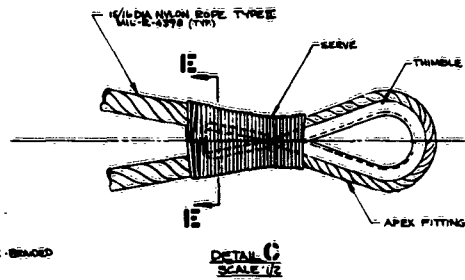
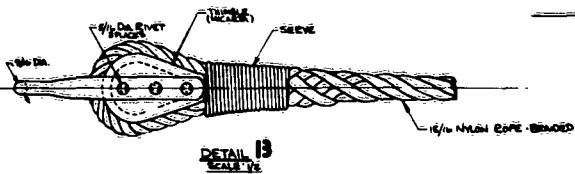
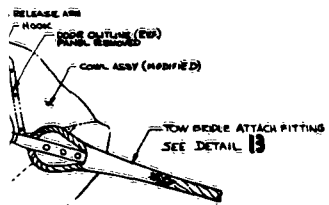
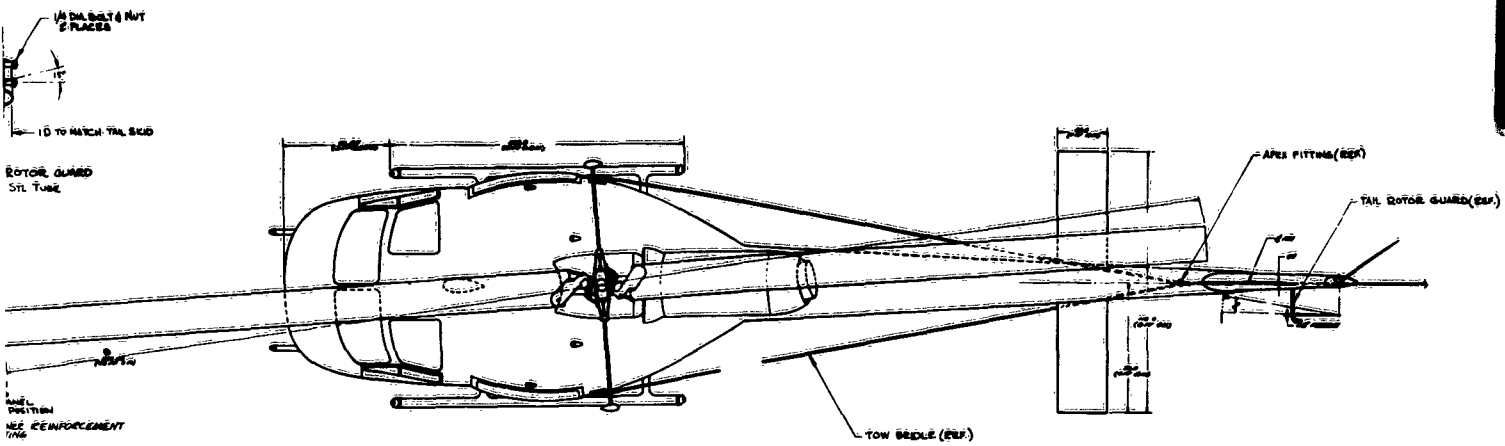

Dwg. 10 - B063-0026 Study-HU-1A Helicopter Modifications for Towing

1

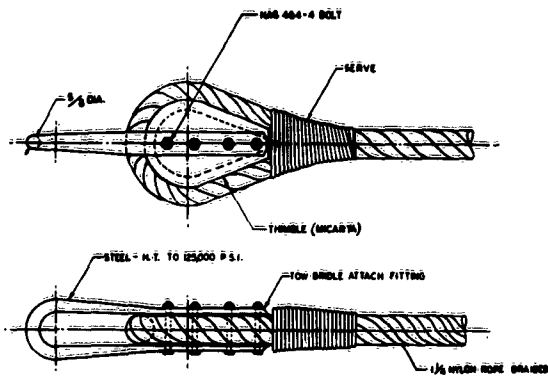

DETAIL A

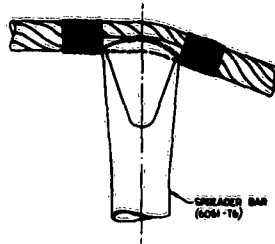

DETAIL B

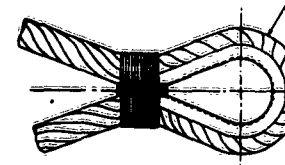

DETAIL C

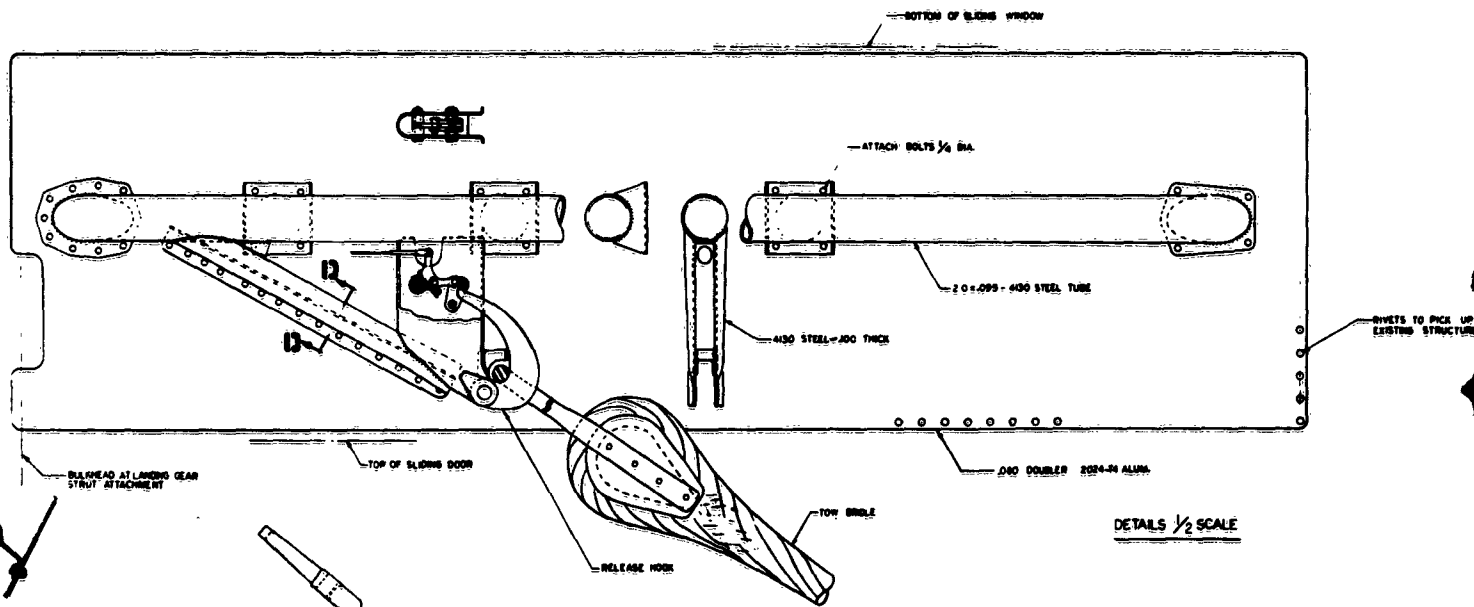

DETAILS 1/2 SCALE



SECTION D-D

RELEASE DETAILS

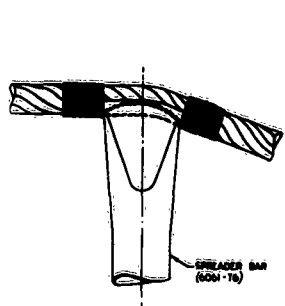

DETAIL B

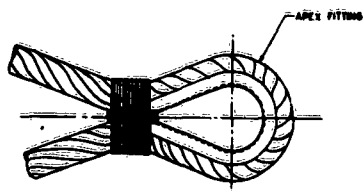

DETAIL C

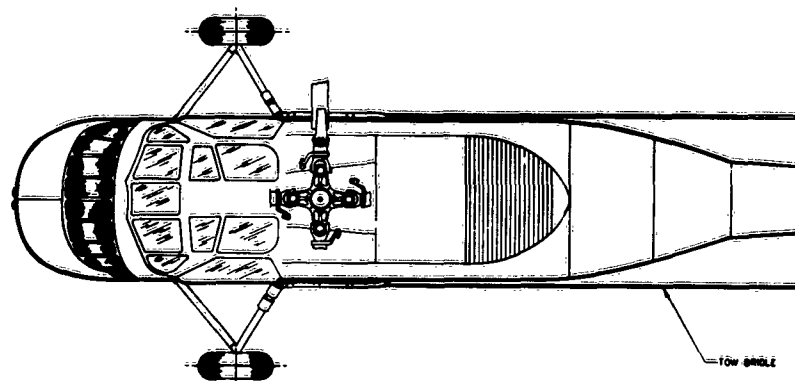

TOW BAR



EXISTING FUSELAGE SKIN

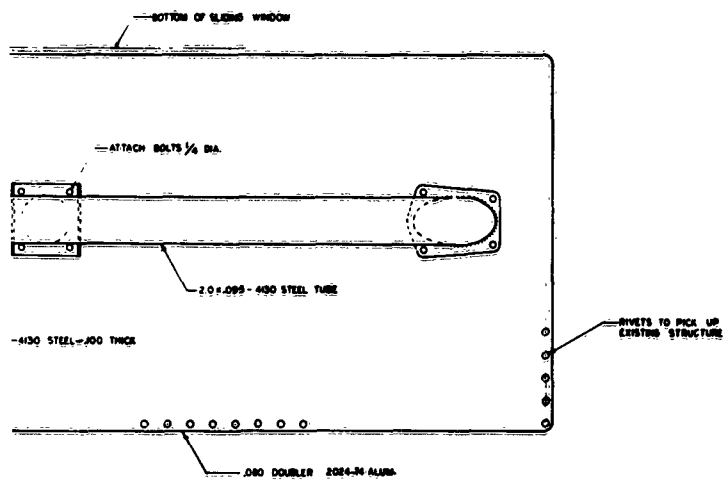

DETAILS 1/2 SCALE

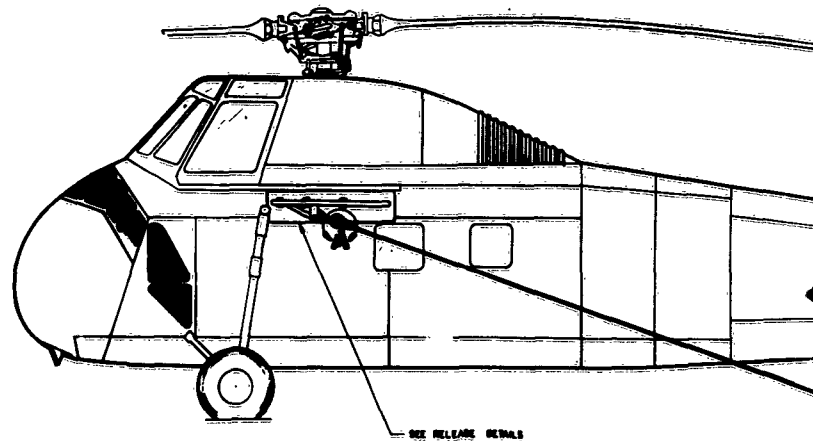

SEE RELEASE DETAILS



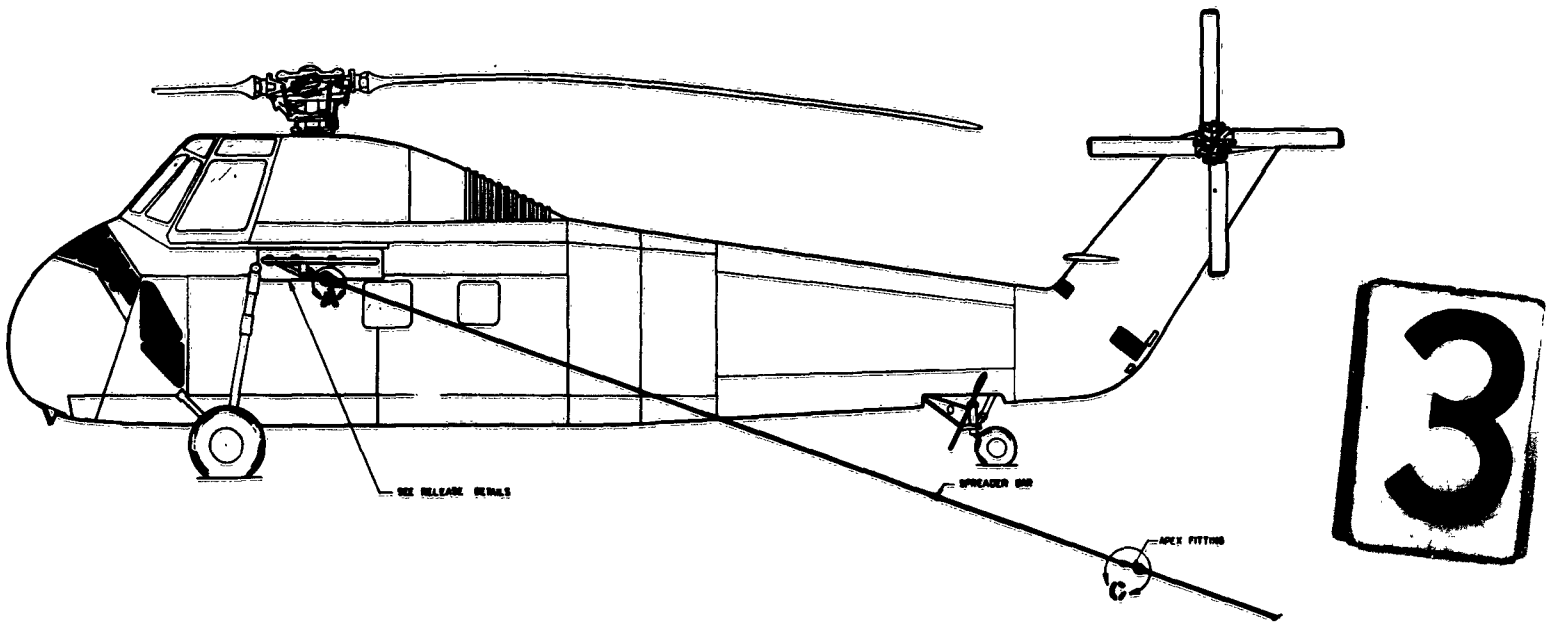
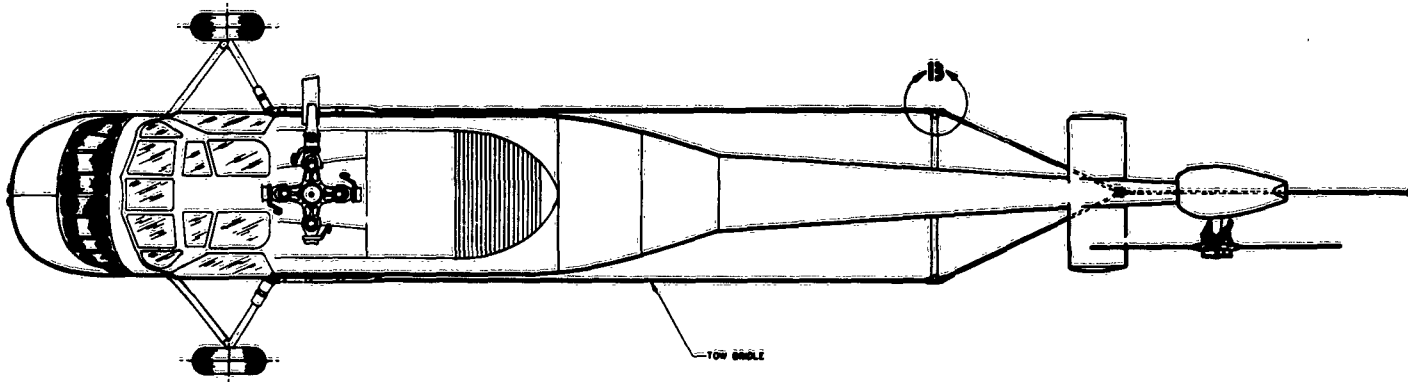

Dwg. 11 - B063-0028 Study - H34 Helicopter Mod. for Towing

VIII. OPERATIONAL UTILIZATION AND EFFECTIVENESS

The Flexible Cargo Glider presents the simplest design to date for achieving ultimate logistical mobility for the U. S. Army. The configurations of the Cargo gliders resulting from this study program are operationally suitable for missions ranging from point delivery of high priority cargo in limited warfare to the requirements of mass movement of bulk materiel, equipment or personnel in a total war.

Operationally, the major advantages of the Flexible Wing Cargo Gliders are categorized as follows:

Increased Effectiveness

The payload capabilities of air and rotor craft standard in the inventory of the U. S. Army are increased several times, without serious degradation of speed and range characteristics, by operating in combination with the towed gliders for logistical missions. The study shows that the maximum design payload of the H-23D will be increased 3.5 times when used as the towing vehicle for the 1,000 pound payload glider, thus adding a new mission role for this helicopter. Characteristically, the larger configurations show improved potentials in payload capability. It is expected that future studies of the "New Light Observation Helicopter" used as the towing vehicle for logistical gliders will demonstrate a far greater potential than previously envisioned in the utility category.

Increased Utilization of the Towing Vehicles

Mission roles of current type of air or rotor craft will be increased by removing the obstacle of cost per ton mile for the logistical mission induced by restricted payload limitations. Vehicles now restricted to the liaisons or courier missions may, in combination with the towed glider, participate profitably in the logistic or re-supply missions.

Low Procurement Cost

Analysis of the configurations developed during the program showed the vehicles to be low cost items. The low ratios of structural weight to payload weight are indicative of the overall simplicity of design and consequently lower procurement and maintenance cost. The cargo compartment may be simple or elaborate, depending on requirements to be established after considering operational environment, design life and expected attrition rates. The control systems are simple. Depending on the operational application, control may range from the simple towing bridle to a remote or automatically controlled guidance unit.

Reduced Personnel Training Cost

Rated personnel will not be required for operations of the gliders in any flight mode. During tow all control and guidance commands are through the towing bridle from the towing vehicle. In one operation of the free flight mode the glider is without directional guidance except by a self-contained control unit that automatically executes the landing flare at the prescribed point prior to touchdown. A remotely controlled system is featured that permits directional control for point landings and may be operated by relatively inexperienced personnel.

Short Take-off and Landing Characteristics

The low wing loadings, used in the configurations of cargo gliders and the matching with the thrust horsepower available in the towing helicopters give a STOL capability. The variable incidence feature of the wing for the landing flare assures a "stop on touchdown" landing.

Shipboard Operations and Ground Mobility

The folding feature of the wing and the wing supporting structure, along with the overall dimensions of the gliders, insure compatibility with the space limitations of LPH-2 type aircraft carriers, or smaller ships for the smaller configurations. Coupled with the STOL take-off characteristics, the Towed Logistics Gliders are highly adaptable to amphibious or ship-to-shore operations. The previously mentioned folding feature of the wing will enhance concealment in the battle area as well as offering added mobility by tractor tow of the vehicle on the ground for dispersal or point delivery.

Stand-Off Delivery in Hostile Areas

The configurations of the Flexible Wing Cargo Gliders evolving from the study program offer the ability for controlled free flight for final delivery at a presented site, and an extension of the load carrying capability of the prime mover. Stand Off deliveries may be made with any of the configurations from distances in excess of ten miles from the point of release from the towing vehicle to the fortified area, thereby increasing the probability of the survival of the towing vehicle. The glider can be accurately guided to a designated landing point through the use of a remote controlled or an automatic homing guidance unit.

Higher Availability

The availability of the logistical prime movers is increased since the configurations presented in this study are not dependent on a single type towing vehicle.

Air Launch Capability

The air launch capability of the 250 and 1,000 pound payload configurations offer a major advancement in air-beachhead or vertical envelopment operations, where the element of surprise through speed or concealment is essential. The gliders of the above configurations may be transported by high speed fixed wing aircraft to the target area while flying low. The gliders are ejected from the cargo compartment or external stores pylons of the carrier aircraft. The flexible wing automatically deploys and the glider assumes a controlled glide path to the final landing point.

IX. DISTRIBUTION

USCONARC	3
First US Army	3
Second US Army	2
Third US Army	2
Fourth US Army	1
Sixth US Army	1
USAIC	2
USACGSC	1
USAWC	1
USAATBD	1
USA AVNS, CDO	1
USAARMBD	1
USAAVNBD	1
USATMC (FTZAT), ATO	1
DCSLOG	2
DCSOPS	1
Rs ch Anal Corp	1
ARO, OCRD	1
OCRD, DA	1
ARO, Durham	2
NATC	2
Ord Bd	1
USA QMCDA	1
CECDA	1
CofT	6
USATCDA	1
USATB	1
USATMC	20
USATC&FE	4
USATSCH	3
USATRECOM	48
USAEWES	1
USA Tri-Ser Proj Off	1
USATRECOM LO, USARD(EUR)	1
USATTCA	1
USATTCP	1
TCLO, USAABELCTBD	1
USACOMZEUR	3
USATDS	5
USARPAC	1

EUSA	1
USATAJ	6
USARYIS/IX CORPS	2
USARHAW	3
USARCARI	4
ALFSEE	2
AFSC (SCS-3)	1
APGC (PGAPI)	1
Air Univ Lib	1
AFSC (Aero Sys Div)	2
CNR	3
BUWEPS, DN	5
ACRD(OW), DN	1
USNPGSCH	1
Dav Tay Mod Bas	1
CMC	1
MCLFDC	1
MCEC	1
MCLO, USATSCH	1
USCG	1
NAFEC	3
NASA, Wash D. C.	6
Geo C. Marshall Sp Fl Cen, NASA	1
Langley Rsch Cen, NASA	5
Ames Rsch Cen, NASA	2
Lewis Rsch Cen, NASA	1
USASG, UK	1
BRAS, DAQMG (Mov & TN)	4
ASTIA	10
HUMRRO	2
MOCOM	3
USSTRICOM	1
Ryan Aeronautical Company	20

AD _____ Accession No. _____
Ryan Aeronautical Company, San Diego,
California. Volume I. Flexible Wing Gliders,
Final Program Summary Report, Volume II,
Flexible Wing Cargo Gliders, Design Criteria
and Aerodynamics.
-- J. L. King, J. E. Fink, C. E. Craiggo.

Report No. TCREC Tech. Report 62-3B
September 15, 1962

____pp (Contract DA-44-177-TC-779)

The final report of a study to determine the
feasibility of the development of cargo gliders
using the Rogallo type Flexible Membrane Wing.
Designs are presented for configurations with
payload capacities of 250, 1,000, 4,000 and
8,000 pounds each. Design and technical
analysis of each configuration is presented.
Requirements for the modification of standard
air and rotor craft to be used for towing or
air launching of the gliders are presented.

AD _____ Accession No. _____
Ryan Aeronautical Company, San Diego,
California. Volume I. Flexible Wing Gliders,
Final Program Summary Report, Volume II,
Flexible Wing Cargo Gliders, Design Criteria
and Aerodynamics.
-- J. L. King, J. E. Fink, C. E. Craiggo.

Report No. TCREC Tech. Report 62-3B
September 15, 1962

____pp (Contract DA-44-177-TC-779)

The final report of a study to determine the
feasibility of the development of cargo gliders
using the Rogallo type Flexible Membrane Wing.
Designs are presented for configurations with
payload capacities of 250, 1,000, 4,000 and
8,000 pounds each. Design and technical
analysis of each configuration is presented.
Requirements for the modification of standard
air and rotor craft to be used for towing or
air launching of the gliders are presented.

Unclassified

1. Flexible Wing
Cargo Gliders,
Design Criteria
and Aerodynamics
2. Contract DA 44-
177-TC-779

AD _____ Accession No. _____
Ryan Aeronautical Company, San Diego,
California. Volume I. Flexible Wing Gliders,
Final Program Summary Report, Volume II,
Flexible Wing Cargo Gliders, Design Criteria
and Aerodynamics.
-- J. L. King, J. E. Fink, C. E. Craiggo.

Report No. TCREC Tech. Report 62-3B
September 15, 1962

____pp (Contract DA-44-177-TC-779)

The final report of a study to determine the
feasibility of the development of cargo gliders
using the Rogallo type Flexible Membrane Wing.
Designs are presented for configurations with
payload capacities of 250, 1,000, 4,000 and
8,000 pounds each. Design and technical
analysis of each configuration is presented.
Requirements for the modification of standard
air and rotor craft to be used for towing or
air launching of the gliders are presented.

AD _____ Accession No. _____
Ryan Aeronautical Company, San Diego,
California. Volume I. Flexible Wing Gliders,
Final Program Summary Report, Volume II,
Flexible Wing Cargo Gliders, Design Criteria
and Aerodynamics.
-- J. L. King, J. E. Fink, C. E. Craiggo.

Report No. TCREC Tech. Report 62-3B
September 15, 1962

____pp (Contract DA-44-177-TC-779)

The final report of a study to determine the
feasibility of the development of cargo gliders
using the Rogallo type Flexible Membrane Wing.
Designs are presented for configurations with
payload capacities of 250, 1,000, 4,000 and
8,000 pounds each. Design and technical
analysis of each configuration is presented.
Requirements for the modification of standard
air and rotor craft to be used for towing or
air launching of the gliders are presented.

Unclassified

1. Flexible Wing
Cargo Gliders,
Design Criteria
and Aerodynamics
2. Contract DA 44-
177-TC-779

<p>AD _____ Accession No. _____ Ryan Aeronautical Company, San Diego, California. Volume I, Flexible Wing Glider, Final Program Summary Report, Volume II, Flexible Wing Cargo Gliders, Design Criteria and Aerodynamics. --J. L. King, J. E. Fink, C. E. Craigo.</p> <p>Report No. TCREC Tech. Report 62-3A, December 28, 1961</p> <p>____pp (Contract DA-44-177-TC-779)</p> <p>The final report of a study to determine the feasibility of the development of cargo gliders using the Rogallo type Flexible Membrane Wing. Designs are presented for configurations with payload capacities of 250, 1,000, 4,000 and 8,000 pounds each. Design and technical analysis of each configuration is presented. Requirements for the modification of standard air and rotor craft to be used for towing or air launching of the gliders are presented.</p>	<p>Unclassified</p> <p>1. Flexible Wing Cargo Gliders, Final Program Summary</p> <p>2. Contract DA 44-177-TC-779</p>	<p>AD _____ Accession No. _____ Ryan Aeronautical Company, San Diego, California. Volume I, Flexible Wing Glider, Final Program Summary Report, Volume II, Flexible Wing Cargo Gliders, Design Criteria and Aerodynamics. --J. L. King, J. E. Fink, C. E. Craigo.</p> <p>Report No. TCREC Tech. Report 62-3A, December 28, 1961</p> <p>____pp (Contract DA-44-177-TC-779)</p> <p>The final report of a study to determine the feasibility of the development of cargo gliders using the Rogallo type Flexible Membrane Wing. Designs are presented for configurations with payload capacities of 250, 1,000, 4,000 and 8,000 pounds each. Design and technical analysis of each configuration is presented. Requirements for the modification of standard air and rotor craft to be used for towing or air launching of the gliders are presented.</p>	<p>Unclassified</p> <p>1. Flexible Wing Cargo Gliders, Final Program Summary</p> <p>2. Contract DA 44-177-TC-779</p>
<p>AD _____ Accession No. _____ Ryan Aeronautical Company, San Diego, California. Volume I, Flexible Wing Glider, Final Program Summary Report, Volume II, Flexible Wing Cargo Gliders, Design Criteria and Aerodynamics. --J. L. King, J. E. Fink, C. E. Craigo.</p> <p>Report No. TCREC Tech. Report 62-3A, December 28, 1961</p> <p>____pp (Contract DA-44-177-TC-779)</p> <p>The final report of a study to determine the feasibility of the development of cargo gliders using the Rogallo type Flexible Membrane Wing. Designs are presented for configurations with payload capacities of 250, 1,000, 4,000 and 8,000 pounds each. Design and technical analysis of each configuration is presented. Requirements for the modification of standard air and rotor craft to be used for towing or air launching of the gliders are presented.</p>	<p>Unclassified</p> <p>1. Flexible Wing Cargo Gliders, Final Program Summary</p> <p>2. Contract DA 44-177-TC-779</p>	<p>AD _____ Accession No. _____ Ryan Aeronautical Company, San Diego, California. Volume I, Flexible Wing Glider, Final Program Summary Report, Volume II, Flexible Wing Cargo Gliders, Design Criteria and Aerodynamics. --J. L. King, J. E. Fink, C. E. Craigo.</p> <p>Report No. TCREC Tech. Report 62-3A, December 28, 1961</p> <p>____pp (Contract DA-44-177-TC-779)</p> <p>The final report of a study to determine the feasibility of the development of cargo gliders using the Rogallo type Flexible Membrane Wing. Designs are presented for configurations with payload capacities of 250, 1,000, 4,000 and 8,000 pounds each. Design and technical analysis of each configuration is presented. Requirements for the modification of standard air and rotor craft to be used for towing or air launching of the gliders are presented.</p>	<p>Unclassified</p> <p>1. Flexible Wing Cargo Gliders, Final Program Summary</p> <p>2. Contract DA 44-177-TC-779</p>