

UNCLASSIFIED

AD 299 659

*Reproduced
by the*

**ARMED SERVICES TECHNICAL INFORMATION AGENCY
ARLINGTON HALL STATION
ARLINGTON 12, VIRGINIA**



UNCLASSIFIED

NOTICE: When government or other drawings, specifications or other data are used for any purpose other than in connection with a definitely related government procurement operation, the U. S. Government thereby incurs no responsibility, nor any obligation whatsoever; and the fact that the Government may have formulated, furnished, or in any way supplied the said drawings, specifications, or other data is not to be regarded by implication or otherwise as in any manner licensing the holder or any other person or corporation, or conveying any rights or permission to manufacture, use or sell any patented invention that may in any way be related thereto.

63-3-1

FTD-TT- 62-1251

CATALOGED BY ASTIA
AS AD NO. 299659

TRANSLATION

PROTECTION OF NIOBIUM FROM HIGH-TEMPERATURE GAS CORROSION

By

A. I. Borisenko

FOREIGN TECHNOLOGY DIVISION

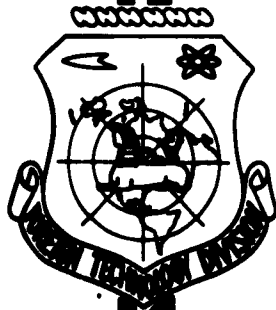

AIR FORCE SYSTEMS COMMAND

WRIGHT-PATTERSON AIR FORCE BASE

OHIO

ASTIA
RECEIVED
APR 3 1963
ASTIA D

UNEDITED ROUGH DRAFT TRANSLATION

PROTECTION OF NIOBIUM FROM HIGH-TEMPERATURE GAS CORROSION

BY: A. I. Borisenko

English Pages: 55

THIS TRANSLATION IS A RENDITION OF THE ORIGINAL FOREIGN TEXT WITHOUT ANY ANALYTICAL OR EDITORIAL COMMENT. STATEMENTS OR THEORIES ADVOCATED OR IMPLIED ARE THOSE OF THE SOURCE AND DO NOT NECESSARILY REFLECT THE POSITION OR OPINION OF THE FOREIGN TECHNOLOGY DIVISION.

PREPARED BY:
TRANSLATION SERVICES BRANCH
FOREIGN TECHNOLOGY DIVISION
WP-APB, OHIO.

AKADEMIYA NAUK SSSR
Institut Khimii Silikatov

ZASHCHITA NIOMIYA OT VYSOKOTEMPERATURNNOY GAZOVOY KORROZII

Izdatel'stvo Akademii Nauk SSSR
Moskva . 1961 . Leningrad

Pages: 1-40

FTD-TT-62-1251/1+2

TABLE OF CONTENTS

	PAGE
Introduction.....	2
Oxidation of Niobium.....	6
Prevention of Gas Corrosion With Protective Coatings.....	15
Composition of Coatings.....	15
Methods of Applying Coatings.....	31
Certain Prerequisites For the Formation of High-Temperature Corrosion Resistant Niobium Alloys.....	39
Conclusions.....	44
References.....	50

This book sets forth the state of the problem of the protection of niobium from high-temperature gas corrosion in the contemporary phase of the problem's development. The causes of the intense oxidation of niobium and its alloys, which may be prevented by applying protective surface coatings that insulate the metal from a gaseous medium, are analyzed. Means of protecting niobium from oxidation are cited and their subsequent development is projected.

This book is intended for engineers and scientific workers concerned with the investigation of the protection of niobium and its alloys from gas corrosion at high temperatures.

INTRODUCTION

The investigations which have been conducted in the field of new heat-resistant materials during the last fifteen years, both here in the Soviet Union and abroad, have shown that iron-nickel alloys with either a chromium or cobalt admixture can resist oxidation at temperatures of up to 1250° ; however, even at 1000° , they soften rapidly. The attempts which were undertaken to increase the strength of these alloys for the purpose of obtaining materials suitable for work under load at temperatures exceeding 1000° did not produce positive results. The fundamental reason for these failures was the impossibility of increasing the flow resistances of the iron-nickel alloys in the hot state. The thermal mobility of the atoms, which increases sharply with increasing temperature, is predominant among the various factors which increase fluidity. The thermal mobility of the atoms can be reduced by metallurgical means at comparatively low temperatures. However, as we approach the melting point of the alloy, it becomes the predominant factor and beyond a certain point, nothing can retard the rise in fluidity. At a given temperature, it is lower in high-melting alloys than in those alloys with an iron, nickel or cobalt base. Therefore it is expedient to take metals with a high melting point as a basis for heat-resistant alloys. This condition, however, is inadequate for an a priori guarantee of flow reduction, since the latter is dependent not only upon the thermal mobility of the atoms, but also upon a whole series of other physicochemical factors, such as, for example, the interatomic bonding forces, the intercrystalline bonding forces, the modulus of elasticity in shear, the coordination number of the atoms in the crystal lattice, the change in entropy, the activation energy, the sublimation energy and so forth. Unfortunately, the contemporary state of our knowledge renders it impossible to

present a quantitative evaluation of flow resistance as a function of all these factors. Therefore, only the qualitative influence of the factors under consideration is usually allowed for in practice.

Research into flow reduction has given rise to the creation of cerametallic materials - the cermets, which are composed of a high-melting oxide and a metallic binder, mixtures of which are treated by the methods of powder metallurgy. The inherent high flow resistances of the cermets have provided a basis for assuming that the required high-temperature corrosion resistant materials may be obtained on the basis of the cermets. It has been found, however, that all cermets, without exception, are brittle. Thus, for example, the impact strength of the cermets fluctuates within the range from 0.01 to 0.20 kilogram-meter/cm², while for the high-melting metals, particularly niobium and molybdenum, it reaches 10-12 and 16-18 kilogram-meters/cm², respectively [1]. Therefore, the creation of alloys on the basis of high-melting metals remains the most promising solution of the problem of high-temperature corrosion resistant materials. Meanwhile, the practical use of the high-melting metals, as well as alloys based on them, encounters great difficulty owing to their high tendency to oxidize. Therefore, the protection of high-melting metals from oxidation is necessary both in the processes of technological operations and under working conditions at high temperatures.

A metal of special interest among those with high melting points is niobium, on the basis of which we may obtain alloys with high mechanical-strength indices. This is because niobium melts at a temperature of $2468 \pm 10^{\circ}$, has a comparatively low specific gravity of 8.57 g/cm³, has good plasticity, welds easily and submits well to mechanical working by forging, broaching, drawing, stamping and so forth. Annealed niobium may be broached without sloughing even against

the direction of rolling [2, page 43].

Niobium shows high strength in the hot state. It is apparent from the data in Table 1, cited by Miller [3, page 401], that the metal retains its high strength up to a temperature of 800°.

TABLE 1

Influence of Temperature on Mechanical Properties of Annealed Niobium

1	Температура, °С	Предел прочности при растяжении, кг/мм ²	Предел пропорциональности, кг/мм ²	4	Удлинение на длине 31.8 мм, %	5	Модуль упругости, кг/мм ²
	20	34.2	28.8		19.2		10700
	200	37.0	24.0		14.2		10300
	300	31.0	20.3		13.2		10200
	400	33.9	22.2		13.3		10200
	500	34.1	19.5		9.6		10000
	600	32.2	12.4		17.5		—
	700	32.2	11.0		22.4		—
	800	31.1	9.0		20.7		—
	900	19.0	8.0		37.5		—
	1000	11.2	6.8		42.5		—

- 1) Test temperature, °C; 2) ultimate tensile strength, kg/mm²; 3) proportionality limit, kg/mm²; 4) elongation on length of 31.8 mm, %; 5) modulus of elasticity, kg/mm².

Comparative data concerning the long-term strengths of niobium and molybdenum are assembled in Table 2 [4, page 57].

The long-term-strength characteristics of niobium tested at temperatures of 982 and 1100° with holding times from 1 to 1000 hours are shown in Fig. 1.

The comparatively low specific gravity, which is particularly important where centrifugal forces act on a material, as well as the excellent weldability of niobium, enable us to use it in place of molybdenum in many cases.

It is known that an increase in the resistance of metals to oxidation can be gained in two ways. The first consists in introducing elements which oxidize and form impenetrable oxide films into the metal requiring protection [5, page 92]. High-temperature corrosion

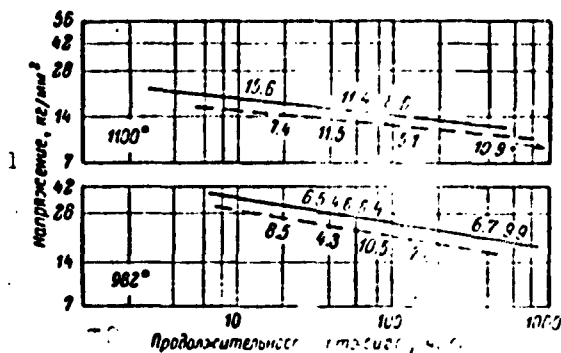

Fig. 1. Long-term strength of technical-grade niobium.

1) Stress, kg/mm^2 ; 2) annealing time, hours; ---- represents rod after 50-per cent upsetting; — represents annealed rod. The figures denote the elongation in the test process in % [4].

resistant steels, which contain chromium, aluminum, silicon and other elements, are classic examples of such alloys. The latter method reduces to the application of protective surface coatings to the metal. The former method, which is based on extensive experience, has shown particularly great promise; this has given impetus to a large number of investigations on niobium alloys. As a result, alloys containing from 44 to 62% of niobium were developed. The

oxidizability of these alloys was sharply reduced as compared to pure niobium, but was not completely eliminated [6]. Subsequent research was conducted on additives to niobium alloys with the object not of

TABLE 2

Long-Term Strengths of Niobium and Molybdenum Tested in Vacuo

1 Металл	2 Подготовка	3 100-часовая длительная прочность, kg/mm^2	
		950°	1030°
4 Ниобий	6 После холодной обработки	19.95	12.95
	6 Рекристаллизованный	23.45	14.10
5 Молибден	6 После холодной обработки	15.40	9.10
	6 Рекристаллизованный	9.10	6.30

1) Metal; 2) preparation; 3) 100-hour strength, kg/mm^2 ; 4) niobium; 5) molybdenum; 6) after cold working; 7) recrystallized.

preventing oxidation of the niobium, but of improving the mechanical properties of niobium at high temperatures. Noticeable advances have been made precisely in this trend of niobium-alloy metallurgy. Thus,

the protection of niobium from oxidation may be accomplished by the latter method - by applying protective surface coatings capable of insulating niobium from the external medium. We should not, however, exclude the possibility of finding high-temperature corrosion resistant alloys based on niobium.

OXIDATION OF NIOBIUM

In an atmosphere of air, cast or sintered niobium undergoes marked oxidation at 700° , while powdered niobium begins to burn as low as 400° . Niobium burns in sulfur dioxide and carbon dioxide at 600° , while in water vapor vigorous oxidation occurs at 900° [7, page 355]. Within the temperature range from 1200 to 1400° , methane and carbon monoxide react with niobium to form a carbide of the composition NbC. At temperatures lower than 600° , carbon monoxide is absorbed by niobium [11, page 17]. On prolonged heating in an atmosphere of air, a change in the color of sheet niobium is observed even at 180° , and beginning at 230° a weight increase occurs in the heated specimen (Table 3).

It has been shown [9] that the oxidation rate of niobium increases if the surface of the specimen which is to be heated in an atmosphere of air is first worked with abrasive materials.

The nature of the crystalline phases formed on the oxide layer is dependent upon temperature (Table 4). According to data from investigations [3, pages 502 and 504], the oxidation rate of niobium also increases where dry air is replaced by moist. Thus, for example, in an atmosphere of air with a 100% relative humidity (at 20°), the oxidation rate of niobium at 600° is greater than that occurring in an atmosphere of dry air by a factor of five. At 1200° , the difference in the oxidation rates of niobium in moist and dry air is insignificant.

TABLE 3

Oxidation of Niobium in an Atmosphere of Air
(area of specimen = 40 cm², sheet thickness =
= 0.1 mm, heating period = 20 hours [8])

1	Температура, °C	Привес. мг на 1 см ² в сутки	3 Цвет образца
	150	0.0	Слегка желтоватый 4
	215	0.0	Бледно-желтый 5
	230	0.2	Желтый 6
	260	0.5	Бронзово-желтый с фиолетовыми пятнами 7
	280	1.2	Фиолетовый с желтыми участками 8
	300	1.5	Ярко-синий 9
	320	4.4	Зеленоватый 10
	340	6.7	Темный, зеленовато-синий 11
	350	7.6	Темный, появление белого 12

1) Temperature, °C; 2) weight increase, mg/decimeter²/day; 3) color of specimen; 4) slightly yellowish; 5) pale yellow; 6) yellow; 7) bronze yellow with violet spots; 8) violet with yellow zones; 9) rich blue; 10) greenish; 11) deep greenish-blue; 12) dark with emergence of white.

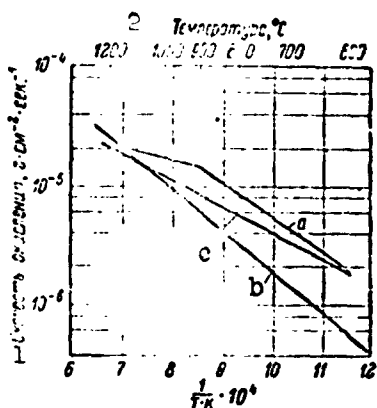

Fig. 2. Relationship of oxidation rate of niobium to temperature. a) In an atmosphere of dry air according to Inoya; b) in an atmosphere of dry air according to Klopp et al.; c) in an atmosphere of moist air [3, page 506].
1) Oxidation rate, g cm⁻² sec⁻¹; 2) temperature, °C.

It has been established by investigation of the oxidation rate of niobium at temperatures of 600, 800, 1000 and 1200° in atmospheres of both moist and dry air that the rate of the oxidation reaction is a linear function of the reciprocal temperature.

Figure 2 shows the data of various authors that confirm the nature of the relationship under consideration for moist and dry air.

In the opinion of Klopp, Sims and Jaffee [10], the oxidation of niobium occurs in three stages:

a) formation of a protective oxide film below a temperature of

375³.

- b) formation of cracks in the solid film from 400 to 500°;
- c) formation of a layer which does not possess protective properties at temperatures greater than 500°.

The external layer of scale which forms on niobium when it is heated in an atmosphere of air consists of a white porous oxide under which is a thin oxide layer either black or gray in color. It has been established that the scale consists mainly of the γ -form of niobium pentoxide. Traces of the lower niobium oxide, that of the composition NbO , have been detected in the inner layer of scale obtained at 1000°. Microscopic investigation has shown that the inner layer of scale is composed of oriented crystals, while the outer layer is a porous mass consisting of nonoriented granules. The inner layer is situated on the surface of the metal and adheres to it firmly, while the latter is readily detached. This loose attachment of the outer layer of scale to the inner layer is due to the disadvantageous ratio between the molecular volume of niobium pentoxide and the atomic volume of metallic niobium, $NbO_{2.5} : Nb$. The above ratio of the volume of the oxide to the volume of the metal is 2.69, with the result that large stresses arise on the interface and the scale is readily detached from the surface of the oxidized metal.

The basic component of the scale is niobium pentoxide. However, niobium oxides of other chemical compositions are also known. The following oxidation products of niobium have been isolated and examined: the pentoxide, dioxide and oxide.

Niobium pentoxide (Nb_2O_5) is a white crystalline substance. According to the data of various authors [11, page 20], niobium pentoxide is homogeneous in the composition range from $NbO_{2.4}$ to $NbO_{2.05}$ and exists in four polymorphic varieties. The polymorphism of niobium

TABLE 4

Composition of Oxide Layer Formed on Oxidation of Niobium

1 Условия		2 Кристаллические фазы		7 Примечание
3 атмосфера	4 температура, °C	5 внутренний слой	6 наружный слой	
8 Кислород	500	α -Nb ₂ O ₅	α -Nb ₂ O ₅	10 Следы NbO во внутреннем слое
9 Воздух	600	α -Nb ₂ O ₅	α -Nb ₂ O ₅	
9 Воздух	800	$\alpha + \beta$ -Nb ₂ O ₅	$\alpha + \beta$ -Nb ₂ O ₅	
9 Воздух	1000	$\beta + \gamma$ -Nb ₂ O ₅	$\beta + \gamma$ -Nb ₂ O ₅	

1) Oxidation conditions; 2) crystalline phases; 3) atmosphere; 4) temperature, °C; 5) inner layer; 6) outer layer; 7) remarks; 8) oxygen; 9) air; 10) traces of NbO in inner layer.

pentoxide is described in the following manner [12]. When heated to 640-800°, the low-temperature α -form is irreversibly transformed into the β -form, which is stable up to 1060°. Above this temperature, a monotropic transformation into the high-temperature γ -form of niobium pentoxide is observed. On further heating of the latter to 1285°, it undergoes a reversible transformation into the γ' -form of niobium pentoxide, which melts without decomposition at 1465°:

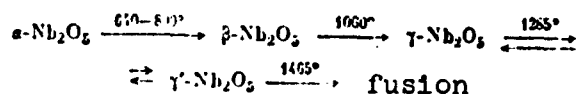

The variations in the values of the transformation temperature are apparently caused by inconstancy in the chemical composition of niobium pentoxide, as well as the differences in the heating rates of the tested specimens, the particle dispersions, purity of the material, and so forth. According to the data of Shafer and Roy [12], the x-ray density of the high-temperature variety of niobium pentoxide obtained by quenching from the melt is 4.53 g/cm³. The elementary cell of γ -Nb₂O₅ is monoclinic with the following parameters:

$$a = 19.63, \quad b = 3.835, \quad c = 20.93 \text{ \AA}, \quad \beta = 120^\circ.$$

The number of molecular units in the elementary cell is 14. According to other data, the specific gravity of niobium pentoxide varies from 4.37 to 5.02 for different modifications.

It has been shown by investigation of the oxidation process of metallic niobium and the polymorphism of niobium pentoxide by the method of high-temperature x-ray analysis [4, page 117] that the oxidation proceeds stepwise, passing through stages of formation of a solid solution of oxygen in the metallic niobium and subsequent formation of niobium pentoxide. This sequence of the oxidation process apparently explains the presence of the wide homogeneity region included in the composition range from $\text{NbO}_{2.05}$ to $\text{NbO}_{2.4}$, so that we may regard the above compositions as intermediate ones in the oxidation of niobium to Nb_2O_5 .

At elevated temperatures, niobium pentoxide reacts with oxides of alkaline, alkaline-earth and rare-earth metals to form niobates, whose individual representatives are characterized by refractory properties and high stability on heating. Niobium pentoxide dissolves in both oxalic and tartaric acids. It also dissolves in concentrated sulfuric acid, but separates out as a precipitate on dilution with water [13, page 158].

Niobium dioxide (NbO_2) is a dark-blue crystalline substance. This phase is homogeneous in the composition range from $\text{NbO}_{1.94}$ to $\text{NbO}_{2.09}$. It can be obtained either by melting niobium pentoxide in a vacuum or by reduction of niobium pentoxide in moist hydrogen at a temperature of 1070° . It is stable at normal temperatures, but when heated in an atmosphere of air up to 850° , it oxidizes and reconverts into niobium pentoxide. Its specific gravity is 6.3 [13, page 157].

Niobium oxide (NbO) crystallizes in the cubic system. In the face-centered lattice, which is similar to the sodium chloride lattice,

the eight vertices of the cube are unoccupied by atoms. Niobium oxide oxidizes to Nb_2O_5 when heated in an atmosphere of air.

In addition to oxygen, niobium also reacts with other gases at elevated temperature. Thus, for example, the ability of niobium to absorb gases - hydrogen, nitrogen, oxygen and others - with the formation of solid solutions is known. The presence of gases dissolved in metallic niobium sharply reduces its plasticity. The solubility of hydrogen in niobium decreases (Fig. 3) with increasing temperature, while the solubility of oxygen increases (Fig. 4). The process of hydrogen solution in niobium is accompanied by the introduction of hydrogen atoms to the niobium lattice without the formation of specific compounds. The high brittleness of niobium hydride is utilized for transforming the dense metal into a powder. Moreover, when niobium hydride is heated, we can obtain pure hydrogen. The thermal dissociation of the solid solution of oxygen in niobium at 1000° is insignificant; at higher temperatures, however, the dissociation vapor pressure increases so rapidly that the oxygen may be evacuated from the metal. Heating a niobium wire to 2000° in a vacuum (residual pressure 10^{-5} mm Hg) enables us to reduce the percentage of oxygen in the wire to values smaller than 0.002%. Therefore, the equilibrium pressure of the oxygen above the solid niobium-oxygen solution exceeds 10^{-5} mm Hg at 2000° [15].

The solubility of nitrogen in niobium is less than 4.8 atom-%. Niobium nitrides are obtained when powdered niobium is nitrated on heating. The higher niobium nitride, $\text{NbN}_{1.00}$, is obtained by heating niobium filings in a nitrogen current at 1300° over a period of 4 to 5 hours, while a nitride of the composition $\text{NbN}_{0.93}$ is evolved at 1450° . When the above nitrides are heated in a vacuum to 1300 - 1400° , nitrides with lower nitrogen contents from $\text{NbN}_{0.88}$ to $\text{NbN}_{0.71}$ are

formed [11, page 151].

When heated in an atmosphere of either air or oxygen, niobium oxidizes vigorously. Particularly rapid oxidation of niobium occurs at temperatures that exceed 900° . It is apparent from the oxidation isotherms shown in Fig. 5 that at a temperature of 1150° in a static atmosphere of air, the weight change in the initial breakdown phase reaches $500 \text{ g} \cdot \text{m}^{-2} \cdot \text{hour}^{-1}$. A graphic presentation of the oxidation rate of niobium in an atmosphere of air is given in Fig. 6.

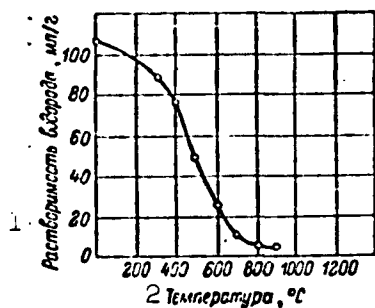

Fig. 3. Dependence of solubility of hydrogen in niobium upon temperature [14, page 135].
1) Solubility of hydrogen, ml/g;
2) temperature, °C.

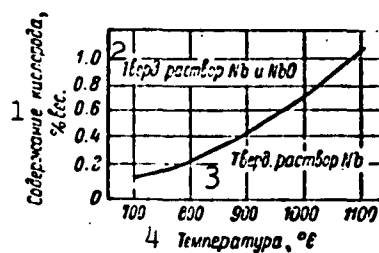

Fig. 4. Dependence of solubility of oxygen in niobium on temperature [15].
1) Oxygen content, % by weight; 2) solid solution in Nb; and NbO; 3) solid solution in Nb; 4) temperature, °C.

As we know, the rate of gas corrosion of molybdenum at elevated temperatures is dependent upon the sublimation of its oxidation products, as a result of which the surface of the metal is constantly exposed and the breakdown process is not slowed [16, page 76]. In the case of oxidation of niobium, the surface oxide layer is not driven off on heating. Nevertheless, when niobium is heated in an atmosphere of air, the gas-corrosion process proceeds quite vigorously. What, however, is the reason for such a rapid breakdown of niobium when it is heated in an atmosphere of gaseous oxidizing agents? Apparently, we should seek the answer in the properties of the oxide layer which forms on the niobium surface in the oxidation process.

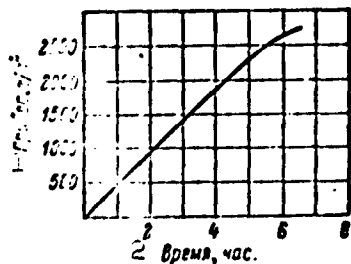

Fig. 5. Isothermal curve of oxidation of niobium in an atmosphere of air at 1150°.

- 1) Weight increase, g/m²;
- 2) time, hours.

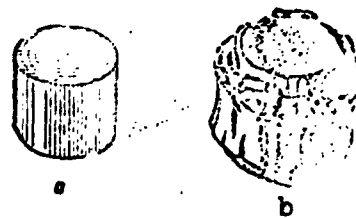

Fig. 6. External appearance of niobium specimens.

- a) Before heating;
- b) after two hours of heating in an atmosphere of air at 1200°.

It was indicated earlier that the fundamental cause of the disintegration of the scale, as a result of which access of gaseous oxidizing agents to the metal is opened, is the large difference between the molecular volume of niobium pentoxide and the atomic volume of metallic niobium. But this is not the only cause of the vigorous oxidation of niobium in an atmosphere of hot gases. The fundamental component of the scale is niobium pentoxide. On heating, niobium pentoxide undergoes polymorphic transformations which are accompanied by a change in specific volume. This change, which is provoked by the $\alpha\text{-Nb}_2\text{O}_5 \rightarrow \gamma'\text{-Nb}_2\text{O}_5$ transformation, is approximately 4.5%. On heating, therefore, a large number of minute cracks, through which direct access to the surface of the niobium is opened to the oxygen, arise in the oxide layer. The fresh oxide layer formed in this manner also changes in volume and the breakdown process of the metal surface continues.

The presence of a comparatively wide homogeneity range of the highest niobium oxide (from $\text{NbO}_{2.4}$ to $\text{NbO}_{2.05}$) prevents the formation of a resistant oxide layer even at temperatures lower than that of the polymorphic transition from the α - to the β -form of niobium pentoxide, since the change in the chemical composition of the oxide layer is

accompanied, in the majority of cases, by volume changes in the products of corrosion. The nonhomogeneity of the oxide phases creates an additional difficulty in finding protective films consisting of high-melting niobates, which are double oxides.

TABLE 5
Behavior of Certain Niobates on Heating

1	2	3	4	5
Ниобаты	Температура плавления, °C	Характер плавления	Полиморфные превращения	Источник
$\text{Na}_2\text{O} \cdot \text{Nb}_2\text{O}_5$	1422	Без разложения	При 354, 562 и 640°	[17]
$3\text{K}_2\text{O} \cdot \text{Nb}_2\text{O}_5$	950	Без разложения	При 732°	[18]
$\text{K}_2\text{O} \cdot \text{Nb}_2\text{O}_5$	1039	Без разложения	Отсутствуют	[18]
$2\text{K}_2\text{O} \cdot 3\text{Nb}_2\text{O}_5$	1163	Без разложения	Отсутствуют	[18]
$\text{K}_2\text{O} \cdot 3\text{Nb}_2\text{O}_5$	1234	С разложением	Отсутствуют	[18]
$3\text{K}_2\text{O} \cdot 22\text{Nb}_2\text{O}_5$	1279	С разложением	Отсутствуют	[18]
$\text{TiO}_2 \cdot 3\text{Nb}_2\text{O}_5$	1480	Без разложения	Отсутствуют	[19]
$\text{TiO}_2 \cdot \text{Nb}_2\text{O}_5$	1490	Без разложения	Отсутствуют	[19]
$6\text{ZrO}_2 \cdot \text{Nb}_2\text{O}_5$	1670	С разложением	Отсутствуют	[19]
$\text{ZrO}_2 \cdot \text{Nb}_2\text{O}_5$	1700 ± 20	Без разложения	Отсутствуют	[20]
$\text{BaO} \cdot \text{Nb}_2\text{O}_5$	1450	Без разложения	При 1200°	[21]
$\text{SrO} \cdot \text{Nb}_2\text{O}_5$	Диссоциирует при $t > 1400^\circ$		Отсутствуют	[21]
$\text{CdO} \cdot \text{Nb}_2\text{O}_5$	1435 ± 5	Без разложения	Отсутствуют	[22]
$2\text{CdO} \cdot \text{Nb}_2\text{O}_5$	1410 ± 5	Без разложения	Отсутствуют	[22]

Note: The niobates of the rare-earth elements (La, Ce, Pr, Nd, Pm, Sm, Eu, Gd, Tb, Dy, Ho, Er, Tu, Yb and Lu) are obtained synthetically. It has been shown that on heating they undergo a reversible transition from a monoclinic variety stable at normal temperatures into a tetragonal variety [23].

1) Niobate; 2) melting point, °C; 3) nature of melting; 4) polymorphic transformations; 5) literature source; 6) without decomposition; 7) with decomposition; 8) dissociates at $t > 1400^\circ$; 9) at 354, 562 and 640°; 10) at 732°; 11) none.

The investigation of high-melting niobates which do not possess polymorphism (Table 5) is of great practical significance from the standpoint of their usefulness in protecting niobium from oxidation at elevated temperatures.

Thus, at temperatures up to 800°, the oxidation of niobium in the first stage is dependent upon the formation of a solid solution

of oxygen in niobium, and in the second stage upon the formation of oxides which are readily separated from the metal. The composition of the oxides under consideration varies as a function of the temperature, the nature of the gaseous medium and the duration of the oxidation process. At temperatures greater than 800° , the predominant cause of the rapid oxidation of niobium is the polymorphism of niobium pentoxide. The polymorphic transformations of niobium pentoxide – the fundamental component of the oxide layer – which are provoked by heating break up the products of corrosion adjoining the surface and open access of oxygen and other gaseous oxidizing agents to the metal.

PREVENTION OF GAS CORROSION WITH PROTECTIVE COATINGS

Composition of Coatings

Various coatings and means of their application have been studied for the protection of niobium from high-temperature gas corrosion. Until recently, the search for protective high-temperature corrosion resistant coatings for niobium had been stimulated mainly by the need for high-temperature corrosion resistant materials in the main and entrance blades of turbojet engines. As we know, very rigid specifications are set forth for the protective coatings on these blades. They must operate at a temperature of approximately 1150° , adhere firmly to the coated surface and possess a high resistance to mechanical and thermal shock. Since the above properties are peculiar primarily to metals and their alloys, metallic protective coatings for niobium were subjected to the most exhaustive investigations. The quality of these coatings is determined by the properties of the metals applied, as well as by the nature of the phases formed in the application process and during the service life of the product at high temperatures. As we noted earlier [16, page 14], high tenacity of the protective layer on the niobium may be guaranteed on observance of at

least two conditions. It is necessary, firstly, that the difference in the magnitudes of the thermal-expansion coefficients of the protective metal and niobium be as small as possible. The smaller the difference, the smaller will be the magnitude of the stresses arising in the transitional layer on heating and oxidation, and the greater will be the resistance to thermal shock. Secondly, we should take metals which form solid solutions with niobium in order to achieve tenacity of the protective metallic layer to the niobium. It is precisely this presence of solid solutions in the intermediate layer between the niobium and the protective metal that governs the high adherence strength and sharply reduces the sensitivity of the coatings to sudden temperature changes. This is explained by the fact that on solution of the protective metal in the niobium, no marked interface arises between the applied and base materials, since the concentration of the solid solution being formed and, consequently, the properties of the solid solution change gradually in the direction from the surface into the interior of the niobium.

Chromium has been used for the protection of niobium from oxidation at temperatures up to 1000° . The selection of chromium as a protective coating material was based on the data of Kubaschewski and Schneider [24] in accordance with which niobium-chromium alloys lying in the phase range of Cr_3Nb_2 (Fig. 7) have elevated resistance to oxidation.* Moreover, the difference between the thermal-expansion coefficients of chromium and niobium is relatively small and varies from $-15 \cdot 10^{-7}$ to $+15 \cdot 10^{-7}$ in the temperature range from 20 to 1000° . At temperatures from 550 to 600° , the values of the thermal-expansion coefficients are the same for the two metals. According to the data of an American firm [25], protection of niobium may be accomplished more effectively than protection of molybdenum, since niobium, unlike

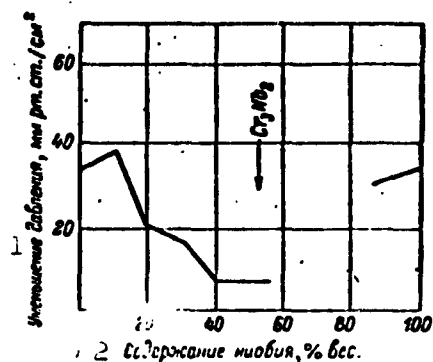

Fig. 7. Oxidation resistance of chromium-niobium alloys. Pressure drop in sealed vessel after heating over a period of 40 minutes [24].

- 1) Pressure drop, mm Hg/cm²;
- 2) niobium content, % by weight.

molybdenum, does not form volatile oxides when heated in an oxidizing medium. Niobium specimens treated by thermal-diffusion chrome-plating methods did not show signs of disintegration after being heated in an atmosphere of air at a temperature of 982° over a period of 320 hours and 13 thermal-shock cycles. The technological details of the thermal-diffusion chrome-plating process are not cited in the firm's report.

The English researcher Sandos [26] proposed a means of protecting niobium and its alloys by immersing niobium objects into molten zinc and then diffusion-annealing them in an atmosphere of air. He showed that, during the immersion, intermetallic compounds consisting of niobium and zinc form on the coated surface. According to Sandos, these intermetallides are formed in any method of using zinc; however, the immersion method is the simplest of them. On diffusion annealing of the zinc-plated niobium at 870° in an atmosphere of air, the formation of intermetallic compounds occurs; on oxidation, they are transformed into mixed oxides - zinc niobates. By themselves, the zinc-niobium intermetallides are brittle and susceptible to the formation of cracks on either mechanical or thermal shock. But on the surface of niobium they show firm adherence to the base metal and high oxidation resistance when heated in an atmosphere of air. The heat resistance discovered by Sandos in the intermetallides under consideration in a static air atmosphere is appraised as follows: several hundred hours at 980°; several days at 1090°; several hours

at 1200°.

A test of the zinc coatings at 1090° in a current of fuel-combustion products traveling with a velocity of 152 m/sec over a period of five hours showed that the niobium does not show signs of disintegration and does not become brittle. The latter attests to the coating's total impermeability to gas, since the brittleness of niobium increases sharply as a result of various gases dissolving in it. Thus, the zinc coatings satisfy the basic requirements - they protect niobium effectively from oxidation in an atmosphere of hot gases. A no less important property of the protective zinc coating is its tendency to "self-heal" which has been confirmed by the following experiment. A groove 6 mm in width was filed into the surface of a galvanized and diffusion-annealed specimen in order to remove the protective layer and expose the niobium surface. Then the notched specimen was placed in an atmosphere of air at 1090° for a period of 20 hours. It was found that heating does not cause breakdown of the niobium, but at the place from which the coating was removed an increase in hardness from 100 to 130 Vickers units is observed. This slight increase in hardness indicates that migration of oxygen and nitrogen into niobium occurs only in the first stage of annealing. Thus, the phenomenon of "self-healing" consists in diffusion of the zinc from the adjoining coating to form an intermetallide which, when oxidized, is converted into a zinc niobate.

The method described by Dovey and Randle [27] for the protection of niobium from oxidation deserves mention. According to this method, protection is accomplished by applying a mixture consisting of aluminum oxide, thorium dioxide and metallic niobium powders. Such a coating was applied in layers; the content of the powdered niobium in the mixture was increased with increasing distance from the surface of the

base metal. After annealing, a uniform protective layer had formed and become closely applied to the niobium. To all appearances, the formation of the uniform gas-tight layer, when the powdered mixture was heat-treated, was dependent upon the oxidation of the niobium granules and subsequent interaction of the resulting niobium pentoxide with aluminum oxide and thorium dioxide and formation of the corresponding niobates:

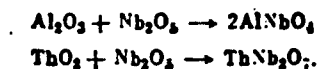

The niobates arising on heat-treatment form a protective layer. Since the presence of niobium pentoxide is an essential condition for the formation of niobates, the heat-treatment may be accomplished either in an oxidizing or a moderately oxidizing medium. The oxygen content in the furnace atmosphere should be such that the powdered niobium, which forms part of the coating, will be transformed into niobium pentoxide. The formation reaction of the aluminum and thorium niobates in the coating occurs at a rapid rate; this was probably due to the high dispersion and the resulting high chemical activity arising on heat-treatment of the niobium pentoxide. Apparently, the authors included powdered niobium in the coating in order to reduce the influence of the diffusion processes, which proceed at an appreciable rate at elevated temperatures and lead to a change in the composition of the protective coating and a reduction of its high-temperature corrosion resistance. This proposition is based on the fact that the initial compositions of the base metal and protective layer are practically unaltered on counterdiffusion of like atoms or ions.

Chester [28] states that alloying the niobium introduced into the coating with molybdenum, vanadium, titanium, chromium and zirconium enables us to increase its high-temperature corrosion resistance.

Among the alloying admixtures under consideration, molybdenum is the most effective. Alloys containing 7.5 atom-% of molybdenum have the lowest oxidizability. Increasing the molybdenum content above 7.5 atom-% results in the formation of the volatile molybdenum trioxide MoO_3 . Vanadium exerts a similar influence. Its optimum content in the alloy is probably 12.5 atom-%. A sharp drop in oxidizability is observed on addition of 25% by weight of titanium to the niobium; this is due to formation of the stable niobates $\text{TiO}_2 \cdot \text{Nb}_2\text{O}_5$ and $\text{TiO}_2 \cdot 3\text{Nb}_2\text{O}_5$. Only when its content in the alloy is 50 atom-% does zirconium reduce the oxidizability of niobium by forming niobium hexazirconate $6\text{ZrO}_2 \cdot \text{Nb}_2\text{O}_5$, which is stable when heated.

TABLE 6
Results of Chemical Analysis of Initial Niobium-Alloys Protective Coatings

2) alloy No.	Содержание, вес. %						
	Nb	Ti	Cr	V	Fe	Ni	Al
D-945	44.7	32.3	14.9	4.84	—	—	4.24
D-947	43.6	31.1	10.2	—	0.76	9.9	3.28
D-948	43.9	30.4	9.76	—	11.5	—	3.98
G-418	42.2	28.7	11.1	—	—	9.2	3.08

Note: The iron in the D-947 alloy was introduced into the powder in grinding.

1) Content, % by weight; 2) alloy No.

Wlodek [29] tested mixed and polymetallic compositions as protective materials on niobium. The protective coatings were applied to niobium specimens with a plasma torch, a cartridge pistol and a gas-flame sprayer.* Two types of coatings were investigated. The coatings of the first type were substances possessing high or moderate resistance to oxidation: NbAl_3 , NbAl , ZrO_2 , Cr, stainless steel, Nichrome V (80% Ni, 20% Cr), LA-4 (70% Nichrome V, 30% Al_2O_3) and LM-5 (40% Mo, 40% Si, 2% B, 8% Cr, 10% Al). The coatings of the second type were

double-layered. The underlayer adjoining the base metal consisted of a niobium alloy (niobium-titanium-chromium-vanadium-aluminum), while the overlayer consisted of either chromium or the LM-5 alloy. The alloys consisting of niobium, titanium, chromium, vanadium and aluminum are characterized by high resistance to oxidation and were therefore selected for the transitional layer between the outer layer and the niobium. Table 6 shows the composition of the niobium alloys after pulverizing to a maximum particle size of 30 μ across, while Table 7 shows the comparative oxidizabilities of niobium, one of the alloys under consideration and stainless steel.

TABLE 7
Oxidation Resistance of Pure Niobium, Type D-947 Alloys, and Stainless Steels

2 Материал	Прирост (мг. см ⁻²) после 100 часов нагревания в атмосфере кислорода при температуре, °C		
	500	1000	1200
3 Ниобий	3630	6670	24000
4 D-947 (47% Nb, 30% Ti, 10% Cr, 10% Ni, 3% Al)	5.58	19.3	229
5 Нержавеющая сталь 304	2.13	8.64	839
Нержавеющая сталь 316	4.91	41.60	131

1) Weight increase (mg.cm⁻²) after 100 hours of heating in an atmosphere of oxygen at a temperature of, °C; 2) material; 3) niobium; 4) stainless steel 304; 5) stainless steel 316.

Coatings were applied to niobium rods 5 to 8 mm in diameter and were tested for high-temperature corrosion resistance in a static atmosphere of air at constant temperature. The oxygen or nitrogen content in the specimens passing the heat resistance test was determined. Resistance to thermal shock, the tendency of coating defects to "self-heal" and the behavior under load were also established. The absence of visible defects arising when the niobium pentoxide is formed was the criterion for the serviceability of the coatings.

TABLE 8

High-Temperature Corrosion Resistance of Protected Niobium Specimens in a Static Atmosphere of Air

1	2	3	4	5	6	7	8	9	10	11	12	13	14	15	16
7	LA (70% никр- ов, 30% Al ₂ O ₃) NAl	Варыным писто- летом 1, 2	125	950	< 1	Разрушение всех образцов 10	10	Хром	10	Хром	187	1150	18	Отслаивание ок- сидной корки	20
7		Варыным писто- летом 1, 2	100	950	1	Разрушение всех образцов 10	10	Хром	10	Хром	187	1150	18	Отслаивание ок- сидной корки	20
8	Никром V	Варыным писто- летом 1	112	950	23	Локальное пора- жение	17	Хром + D-945	Хром + D-945	100+75	1150	От 0 до 1	Локальное пора- жение	17	
8	Никром V	Варыным писто- летом 1	112	950	500	Окисление всей поверхности 13	13	LM-5	LM-5	75	950	< 700	Окисление всей поверхности	13	
8	Никром V	Варыным писто- летом 1, 2	112	1150	104	Окисление всей поверхности 13	13	LM-5	LM-5	75	1150	192	Окисление всей поверхности	13	
8	Никром V	Газопламенным 1, 2 1, 2 1, 2	250	1150	168	Локальное пора- жение	17	LM-5	LM-5	75	1150	> 1008	Слабое окисление поверхности нет	17	
8	Никром V	Газопламенным 1, 2 1, 2 1, 2	240	1150	500 ± 10	Окисление всей поверхности 3	3	LM-5	LM-5	187	1150	> 1008	Слабое окисление поверхности нет	17	
8	Никром V	Газопламенным 1, 2 1, 2 1, 2	250	1250	25	Окисление всей поверхности 3	3	LM-5	LM-5	200	1150	> 1050	Слабое окисление поверхности нет	17	
8	Никром V	Газопламенным 1, 2 1, 2 1, 2	250	1250	25	Окисление всей поверхности 3	3	LM-5	LM-5	112	1250	940	Окисление всей поверхности	18	
8	Никром V	Газопламенным 1, 2 1, 2 1, 2	112	950	28	Локальное пора- жение	17	LM-5	LM-5	162	1250	680	Локальное пора- жение, окисле- ние поверхности	25	
9	Нержавеющая сталь 302	Варыным писто- летом 1	112	950	366	Окисление всей поверхности 13	13	LM-5	LM-5	112	1250	672	Локальное пора- жение, окисле- ние всей поверх- ности	24	
9	Нержавеющая сталь 302	Варыным писто- летом 1	112	1150	8	Окисление всей поверхности 13	13	LM-5	LM-5	112	1250	672	Локальное пора- жение, окисле- ние всей поверх- ности	24	
9	Нержавеющая сталь 302 NbAl ₃	Варыным писто- летом 1	112	950	6	Пористое покры- тие	19	LM-5	LM-5	112	1250	672	Локальное пора- жение, окисле- ние всей поверх- ности	24	
	NbAl ₃	Варыным писто- летом 1, 2	112	950	22	Пористое покры- тие	19	LM-5	LM-5	100	1500	84	Окисление всей поверхности	18	
	NbAl ₃	Варыным писто- летом 1, 2	50	950	> 2	Пористое покры- тие	19	LM-5	LM-5	112	1500	108	Окисление всей поверхности	18	
10	ZrO ₂	Плазменной го- релкой 1, 4	87	950	5	Отслаивание ок- сидной корки	20	LM-5	LM-5	112	1500	От 6 до 10	Взаимодействие с дегидратом	25	
10	Хром	Плазменной го- релкой 1, 4	100	950	555	Окисление всей поверхности	13	LM-5 + D-945	LM-5 + D-945	100+125	1150	> 1050	Пораженный мет. слабое окисле- ние	26	
10	Хром	Плазменной го- релкой 1, 4	87	1150	> 0.5	Отслаивание ок- сидной корки	20	LM-5 + G-418	LM-5 + G-418	100+100	1250	672	Образование трещин при взаимодей- ствии с металлом	27	
10	Хром	Плазменной го- релкой 1, 4	187	1150	165	Окисление всей поверхности	13	LM-5 + G-418	LM-5 + G-418	100+100	1500	От 6 до 10	Взаимодействие с дегидратом	25	
10	Хром	Плазменной го- релкой 1, 4	187	1150	40	Локальное пора- жение	17	LM-5 + G-418	LM-5 + G-418	100+100	1500	От 6 до 10	Взаимодействие с дегидратом	25	
10	Хром	Плазменной го- релкой 1, 4	187	1150	< 1	Порча и отслаива- ние покрытия	21	LM-5 + G-418	LM-5 + G-418	100+100	1500	От 6 до 10	Взаимодействие с дегидратом	25	
10	Хром	Плазменной го- релкой 1, 4	187	1150	< 1	Порча и отслаива- ние покрытия	21	LM-5 + G-418	LM-5 + G-418	100+100	1500	От 6 до 10	Взаимодействие с дегидратом	25	

TABLE 8 (continued)

Note: The LM-5 + D-945 coating was drilled to test for the tendency to "self-heal;" subsequently, the specimen was heated at 1050° over a period of 138 hours and did not show signs of coating breakdown in the areas which remained intact.

1) Protective coating; 2) method of application; 3) coating thickness; μ ; 4) test temperature, °C; 5) high-temperature corrosion resistance, hours; 6) nature of corrosion damage arising on heating; 7) LA (70% Nichrome, 30% Al_2O_3); 8) Nichrome V; 9) stainless steel 302; 10) chromium; 11) chromium + D-945; 12) cartridge gun; 13) gas-flame sprayer; 14) plasma torch; 15) cartridge gun + plasma torch; 16) destruction of all specimens; 17) local damage; 18) oxidation of entire surface; 19) porous coating; 20) scaling of coating; 21) deterioration and scaling of coating; 22) weak oxidation, no damage; 23) local effect, surface oxidation; 24) local damage, oxidation of entire surface; 25) reaction with holder; 26) no damage, weak oxidation; 27) formation of cracks on extraction from furnace.

The high-temperature corrosion resistance tests were conducted in a horizontal tubular furnace in which coated niobium rods secured at one end by a corundum holder were heated to temperatures of 950 and 1150°. When the specimens were heated to 1500°, the corundum holder was replaced by a pure molybdenum disilicide holder. The results of the high-temperature corrosion resistance tests, which are given in Table 8, show that where the layer thickness is from 75 to 100 μ , protective stainless steel 302, chromium, Nichrome V and LM-5 coatings can prevent oxidation of niobium in a static atmosphere of air at 950° for periods of 350, 500, 550 and 700 hours, respectively. At a temperature of 1150°, the same coatings and thicknesses will protect niobium from oxidation over periods of 8, 100, 165 and beyond 1050 hours, respectively. The LM-5 coating retains its protective properties at even higher temperatures: a coating with a thickness of 112 μ prevents gas corrosion of niobium at 1250° for a period of 840 hours, while with the same thickness but at a temperature of 1500°, corrosion is prevented for a period of more than 100 hours. A double-layered

TABLE 9

Microhardness of Protected Niobium After Testing for High-Temperature Corrosion Resistance

Защитное покрытие	Температура испытаний, °C	Продолжительность испытаний, час.	Переходный слой		Внутренний слой		Содержание кислорода в ниобии после удаления покрытия, вес. %	
			4 микро-твердость по Виккерсу, кг/мм ²	5 ширина, мм	6 наибольшая микро-твердость, кг/мм ²	7 ширина, мм		
11 Нихром V	950	23	205—160	0.150	140 ¹	Отсутствует	0.07	
12 Нихром V	1150	500	225—200	0.075	200	62.5 ²	—	
12 Нержавеющая сталь 302	950	366	172—160	0.150	150 ¹	Отсутствует	0.08	
13	Хром	950	555	300—240	0.175	200	31.25 ³	0.49
	Хром	1150	40	250—220	0.250	210	1.75	0.13
	LM-5	950	700	150—140	0.150	125 ¹	Отсутствует	0.08
	LM-5	1150	100 ⁸	150—140	0.075	130 ¹	Отсутствует	—
	LM-5	1150	100 ⁸	175—160	0.150	150 ¹	Отсутствует	—
	LM-5	1250	840	300—170	0.125	120 ¹	Отсутствует	—
	LM-5+D-945	1150	1150	295—160 ³	0.100 ³	130 ¹	Отсутствует	—

Notes: 1) Corresponds to the initial hardness of the layer that adjoins the coating.

2) The entire specimen was contaminated to the hardness level indicated. 3) Includes the width and hardness of the D-945 coating.

1) Protective coating; 2) test temperature, °C; 3) duration of tests, hours; 4) Vickers microhardness, kg/mm²; width, mm; 6) transitional layer; 7) internal layer; 8) greatest microhardness, kg/mm²; 9) width, mm; 10) oxygen content in niobium after removal of coating, % by weight; 11) Nichrome V; 12) stainless steel 302; 13) chromium; 14) not present.

coating in which the underlayer is a niobium alloy and the overlayer is LM-5 has approximately the same protective properties as a coating of LM-5. In a static atmosphere of air, the protective properties of the coatings increase with increasing thickness. Wlodek avers that the high-temperature corrosion resistance of the coatings tested is described adequately by the equation:

$$R = K \cdot t$$

where x is the coating thickness in μ ; t is the resistance of the coating in a static atmosphere of air in hours; K is a proportionality constant, $\mu^2 \cdot \text{hour}^{-1}$.

We should note that LM-5 is the only coating which may be used effectively at temperatures exceeding 1250° . Nichrome V and chromium are effective only at temperatures below 1150° ; here, Nichrome V should be preferred for temperatures that exceed 1050° , and chromium for temperatures lower than 1050° . The stainless steel 302 coating is extremely effective for prolonged protection of niobium at temperatures below 1000° .

The microhardness method was used to determine the quantity of oxygen or nitrogen that migrated through the coating layer and dissolved in the niobium during the process of testing for high-temperature heat resistance. Data on the thickness and microhardness values of the niobium layer containing the dissolved gases are shown in

Table 9 [29].

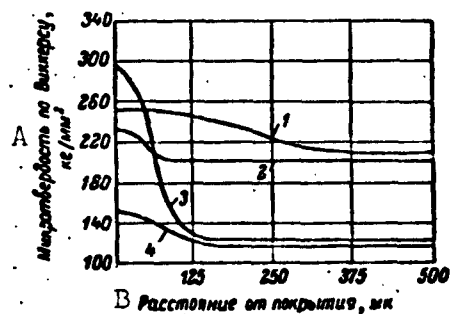

Fig. 8. Variation in microhardness over depth of niobium specimens tested for high-temperature corrosion resistance in static atmosphere of air at 1150° . A) Coatings: 1) chromium, 40 hours; 2) Nichrome V, 500 hours; 3) LM-5 + D-945, 1050 hours; 4) LM-5, 1008 hours. B) Vickers microhardness, kg/mm^2 ; C) distance from coating, μ .

It is apparent from Fig. 8, which shows the change in microhardness down the depth of the coated niobium tested for high-temperature corrosion resistance, that a layer with a thickness from 50 to 125μ which adjoins the coating possesses increased microhardness. Wlodek assumes that the increase in microhardness of the coated niobium in the process of testing for high-temperature corrosion resistance is dependent upon two factors: solution of the coating material in a surface layer

of the niobium from 50 to 125 μ deep and the infiltration of atmospheric gases through the coating to a depth of more than 125 μ ; this is noted particularly on specimens coated with chromium and Nichrome V. The infiltration of oxygen into the niobium through the damaged areas of the coating is illustrated in Fig. 9. A specimen coated with LM-5 to a thickness of 187 μ was heated in an atmosphere of air at 1150° over a period of 1008 hours; the coating was then damaged and the specimen reheated for a period of 138 hours at 1050°. The microhardness of oxygen-contaminated zones on a polished microsection was 180, while the uncontaminated area showed 140 Vickers units.

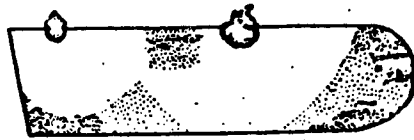

Fig. 9. Resistance of LM-5 coating to oxygen infiltration. Clear portions correspond to oxygen contaminated niobium. Corrosion by a mixture of hydrofluoric acid: nitric acid; glycerol = 1:1:2. Magnification 3X.

The resistance to thermal shock was determined by Wlodek only for the LM-5 and the LM-5+ niobium alloy coatings because they possess the highest high-temperature corrosion resistance indices in a static atmosphere of air. The high-temperature corrosion resistance was estimated from the number of thermal shocks and from the duration

of heating prior to the appearance of the first signs of coating breakdown. After being heated to 1150°, the coated specimens were removed from the furnace and cooled to room temperature in either air or water and were then replaced in a furnace heated to the same temperature. Over a period of 24 hours, the test specimens were subjected to three thermal-shock cycles in accordance with the schedule: 1150 → 20 → 1150°. The results of the thermal-shock resistance tests of the coatings are assembled in Table 10.

It is characteristic that the LM-5 coating withstands up to 30 thermal-shock cycles in air without breakdown, but is impaired after 3

to 5 cycles when cooled in water. The double-layered coatings possess a greater resistance to thermal shock than do the LM-5 coatings. The LM-5 + D-947 (Nb, Ti, Cr, Al and Ni alloy) and LM-5 + D-948 (Nb, Ti, Cr, Al and Fe alloy) double coatings withstand from 21 to 30 thermal shocks when chilled in water. Wlodek assumes that the high resistance to thermal shock observed in the double-layer coatings is dependent upon the presence of small quantities of liquid phase in the Nb-Ti-Cr-Al-Ni and Nb-Ti-Cr-Al-Fe alloys. When the alloys under consideration are heated to 1200°, their liquid-phase content is 20-30% by

TABLE 10

Resistances of LM-5 Coating and LM-5 + Niobium Alloy Double Coating to Thermal Shock

1 Тип покрытия	2 Толщина, мк	3 Охлаждение	4 Число циклов	5 Продолжительность испытаний до начала разрушения, час	6 Примечание	
LM-5	187	Воздушное	31	194	Покрытие не разрушалось	
LM-5	187	Воздушное	27	167		
LM-5	187	8 Закалка в воде	3	142	До испытания на термостойкость образцы нагревались 120 час при 1150° в статической атмосфере воздуха	
LM-5	187		5	154		
LM-5 + D-945	100+100	8 Закалка в воде	7	136		Появились трещины
LM-5 + D-947	100+75	8 Закалка в воде	30	267		Появились трещины
LM-5 + D-947	100+75	8 Закалка в воде	24	188		Появились трещины
LM-5 + D-948	100+75	8 Закалка в воде	21	248		Появились трещины
LM-5 + D-948	100+75	-	-	-		Появился дефект в покрытии

1) Type of coating; 2) thickness, μ ; 3) cooling; 4) number of cycles; 5) duration of test to onset of breakdown; 6) remarks; 7) air; 8) chilling in water; 9) coating did not break down; 10) before testing for thermal-shock resistance, the specimens were heated for 120 hours in a static atmosphere of air at 1150°; 11) cracks appeared; 12) defects appeared in coating.

volume; however, when the alloys are sprayed on with a plasma torch, loss of the low-melting alloy ingredients occurs and the quantity of

liquid phase in the coating is reduced to 5%. Figure 10 shows the microstructure of the double-layered coating.

The tendency of the coatings to "self-heal" was studied by Wlodek on three specimens, two of which were protected with LM-5 coatings, while the third was insulated with an LM-5 + D-945 coating. The specimens were first heated in an atmosphere of air at 1150° for a period of 1000 hours and did not show signs of coating breakdown. After testing for high-temperature corrosion resistance, holes with diameters of 0.337, 0.50, 0.775 and 1.00 mm were drilled in the protective surface coating. The depth of the holes was somewhat greater than the layer thickness of the protective coatings. Then, the specimens with the drilled coatings were again exposed to an atmosphere of air at 1050° with the intention of ascertaining the oxidation intensity in the defective areas. It was found here that even after the specimens had been heated for only 18 hours, accumulations of niobium pentoxide crystals appear in the defective areas of the coating. The quantity of niobium pentoxide formed on the LM-5 + D-945 double-layered coating was smaller than that on the LM-5 coating. A microscopic study of a polished microsection after etching by a mixture of hydrofluoric and nitric acids enabled us to ascertain the size of the seats of the corrosion damage to the niobium and the zones where it had become contaminated with dissolved gases. A comparison of the results of the microscopic study of specimens that had been heated over a period of 138 hours at 1050° after breaking of the continuity of the coatings showed that the double-layered LM-5 + D-945 coating possesses greater protective properties than does the single-layered LM-5 coating. It is characteristic that in those areas where the coating remained intact, there were no signs of contamination of the niobium by dissolved gases regardless of the fact that prior to the

impairment of the protective layer, the specimens had been heated in an atmosphere of air at 1150° for more than 1000 hours (Fig. 9).

In addition to high-temperature corrosion resistance, Wlodek also studied the influence of the protective coatings on resistance to creep. The tests showed that subsequent to heating in an atmosphere of air for a period of 100 hours at a temperature of 1093°, niobium shielded by the LM-5 coating possessed almost the same resistance to creep as did niobium heated in a vacuum.

In Wlodek's opinion, of all the coatings tested, the LM-5 coating, which consisted of Mo-Si-Cr-E-Al alloy either alone or taken in combination with either the D-948 or the G-418 coating is the most effective. Coatings of this type prevent gas corrosion of niobium in a static atmosphere of air at temperatures greater than 1100°. Thus, for example, an LM-5 coating with a thickness of 125 μ protects niobium from oxidation at 1150° for approximately 700 hours, and at 1500°, the same coating with a thickness of 112 μ shields niobium from gas corrosion for a period of 108 hours (Table 6). Wlodek explains the high resistance to oxidation that is characteristic of the LM-5 coating by the high-temperature corrosion resistance of molybdenum disilicide - the basic component of the protective layer. In his opinion, within the temperature range from 1100 to 1550°, the molybdenum is partially vaporized in the form of MoO₃ and a thin film of silicon dioxide is formed on the surface of the molybdenum disilicide. The formation of the protective silica film is hindered by the slow reaction rate at temperatures below 1100°, while at temperatures that exceed 1550°, it is hampered by the volatility of the silicon oxide SiO₂. Some increase in the high-temperature corrosion resistance of molybdenum disilicide is attained by the introduction of chromium, boron and aluminum into the coating. The presence of aluminum con-

tributes to the formation of oxidation-resistant mullite - $3Al_2O_3 \cdot 2SiO_2$ in the surface layer, while the presence of boron and chromium contribute to the formation of a protective film at temperatures below that of the formation of mullite and cristobalite. Although the experimental data show unequivocally that the LM-5 coating resists oxidation at 1550° rather effectively, we should remember that its reliable service under operating conditions may be guaranteed at

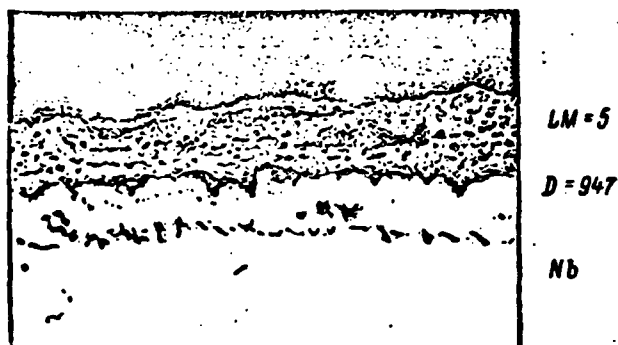

Fig. 10. Double LM-5 + D-947 coating after 188 hours of thermal-shock testing. 37 chillings in water from a temperature of 1150° . Magnification 200X [29].

temperatures below the melting point of niobium pentoxide,* the formation of which is possible due to accidental isolated imperfections in the coating. The appearance of liquid niobium pentoxide can cause exceedingly rapid oxidation of niobium.

In conclusion, Wlodek deems it necessary to allow in evaluation of the results of the tests of the coatings that he described for the fact that the coatings were applied on specimens of comparatively simple form and that the technical properties of the coatings were determined in a static atmosphere of air. On transition to more complex shapes in objects operating in a stream of hot gases and under conditions of dynamic loading, it will be necessary to study other properties of the protective layers, for example, the resistance to

erosion, to mechanical shock, and so forth.

Methods of Applying Coatings

A majority of the methods used for the protection of molybdenum [16] have been adapted for the application of protective coatings to niobium. Depending on the composition of the coatings and the shape, dimensions and functions of the coated objects we may use plating, plating from the gaseous phase, diffusion saturation, building-up, gas-flame spraying, immersion, nonannealing heat-treatment, and spraying with the plasma torch. Extreme difficulties arise in application of the galvanic method of applying protective coatings to niobium; this is due to the tendency of niobium to form hydrides with a variable hydrogen content.

When the niobium hydrides are heated, they decompose with formation of hydrogen, evolution of which under the coating readily breaks the firm adherence of the protective layer to the niobium.

To facilitate the combination of niobium with other metals and to reduce the rate of the diffusion processes, Bich [Beech?] investigated the electrolytic plating of copper, chromium, gold, iron, nickel and platinum to niobium [4, page 432]. He showed that preliminary etching of the niobium surface in solutions of hydrofluoric acid with alternating current before the coatings were applied contributes to an increase in the strength of adherence. The electrolytic etching was conducted at room temperature in a 49% hydrofluoric acid solution with an AC voltage of 1 to 5 volts and a current density of from 21 to 105 amp/dm², respectively. The gray deposit formed by the electrolytic etching was easily removed by a mixture of nitric and hydrofluoric acid solutions. The compositions of the baths and the conditions for the electrolytic plating were selected for each metal. It was found that immediately after plating, only the iron and nickel coatings

possessed adequate adherence to niobium. All other coatings tested were readily removed by scraping with a knife. To increase the strength of adherence of the coatings to niobium, Bich subjected the coated specimens to homogenization at 815°. After homogenizing, only iron formed firmly adhering coatings. Annealing of iron coatings with thicknesses of 0.0076 and 0.0127 mm over a period of 328 hours at a temperature of 815° contributed to the formation of an intermetallic layer which adhered poorly to the niobium. When the tempered specimens were bend-tested, partial detachment of the iron coating was observed: thus, for example, after bending of the original 0.0127 mm thickness of the iron coating, only 0.0025 mm was retained; the rest had peeled off. The experiments showed that this layer consists of a dense iron-niobium alloy which is formed at the 815° temperature. This alloy may serve as an underlayer for coatings of other metals. The other metals tested as electrolytic coatings did not adhere tenaciously to the niobium.

The electrolytic deposition of iron on niobium was conducted at a temperature of 60° and a current density of 3.2 amp/dm² in a bath of the following composition:

FeSO ₄ ·7H ₂ O	-	300 g/liter
FeCl ₂ ·4H ₂ O	-	42 g/liter
(NH ₄) ₂ SO ₄	-	15 g/liter
HCOONa	-	15 g/liter
Wetting agent	-	1 g/liter

Unfortunately, Bich did not cite any data relating to the behavior of the iron coatings at temperatures that exceed 815° and the question as to the feasibility of using an iron underlayer when applying coatings resistant to oxidation at temperatures from 1000 to 1150° remains

unclear.

Reports have recently appeared regarding the use of the plasma torch for application of high-melting protective coatings to various materials. The plasma torches enable us to obtain a flame temperature higher several times than that of the most advanced gas torches in which a mixture of gaseous hydrocarbons is burned with oxygen. The source of heat in a plasma torch is a flux of ionized gas. The generation of heat is accomplished by passing the gas through an arc discharge induced between rod and ring-shaped electrode. The gas passes through a refrigerated channel in the direction from the rod cathode to the ring-shaped anode and is ionized in the gap of the arc. The ionized stream issuing from the ring-shaped anode takes the form of an intensely luminous cone which is enclosed by a less luminous flame (Fig. 11). The flame temperature may reach $30,000^{\circ}\text{C}$ [31]. The apparatus forming the ionized flux consists of three basic parts (Fig. 12): the rod cathode, a channel in which the electric arc is struck and the ring-shaped anode. Either tungsten or carbon is generally used for the cathode, and copper serves as the material for the channel and ring-shaped anode. The tungsten or carbon rod may be shifted axially and set at the required distance from the outlet opening of the ring electrode. Generally, nitrogen, argon, hydrogen and occasionally a mixture of argon and helium are used to set up the ionized stream [33]. It is stated in the report [32] that the plasma torch can operate even on a stream of air; in this case, however, it is necessary to shield the material of the rod cathode from oxidation.

Studying the heat characteristics of a miniature plasma torch [33], Kulagin and Nikolayev showed that the greatest influence on the effective heat output of the ionized flux* is exerted by the distance to which the cathode rod is sunk into the channel, the magnitude of the

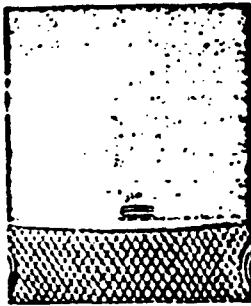

Fig. 11. Flame of plasma torch.

arc current and the flow rate and composition of the gas. The authors established that sinking the arc directly in the channel, intensification of the arc current and increasing the gas flow rate lead to a rise in the effective heat output of the ionized stream. For low gas flow rates into the channel, low efficiency is observed in the heating of the objects by the ionized stream; this is apparently due to an increase in heat transfer from the arc trunk to the walls of the channel.

The replacement of pure argon by a gaseous mixture consisting of 86% helium and 14% argon enables us to double the effective heat output of the ionized stream. The authors consider that this increase in

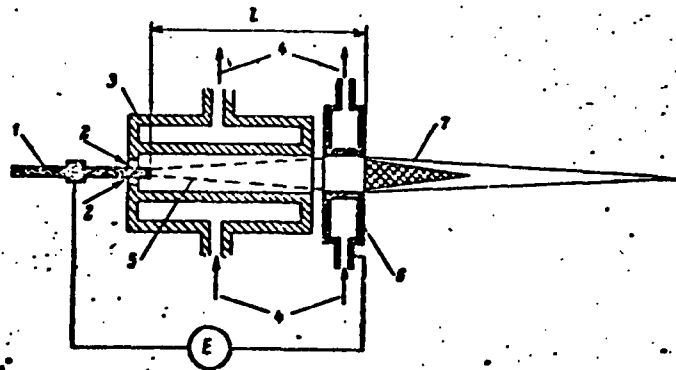

Fig. 12. Diagram of apparatus for production of ionized stream.
 1) Rod electrode; 2) incoming gas; 3) channel; 4) cooling water; 5) trunk of arc; 6) ring-shaped electrode; 7) ionized stream; L is the distance the electrode is sunk; E is the power supply (33).

output is dependent upon the high ionization potential of helium.

At present, it is unknown how exactly the relationships established by Kulagin and Nikolayev may be reproduced on transition from a laboratory to an industrial plasma torch. One thing is definite – the ionized stream is a high-intensity and concentrated source of heat. The use

of the plasma torch may be found highly promising in engineering in general and for the application of various kinds of coatings in particular.

Fossen [31] states that it is possible to apply high-melting powders to the most diverse materials with the use of the plasma torch. The resultant layers adhere very firmly to the coated surface with metallic armor plates, carbon, graphite and other materials. In this case, the applied coating adheres to the coated material more firmly than does a coating applied by galvanization, vaporization in a vacuum or by the method of gas-flame spraying. A characteristic property of the coatings applied with the plasma torch is their high density, which approaches the theoretical.

The author stresses the fact that the range of application of these coatings is exceedingly wide and is expanding into many branches of industry.

Plasma torches have come into widespread use in the refractories industry in the manufacture of crucibles for smelting of high-melting materials. It has been shown that the plasma torch enables us to obtain thin-walled crucibles made of quartz glass; this cannot be accomplished with the gas-flame set-up. Here, the crucibles obtained are durable and nonporous and have uniform smooth surfaces. The wall thickness of the crucibles obtained by the methods of ceramic technology is 3 to 6 mm; it is possible to obtain crucibles with wall thicknesses from 0.1 to 0.15 mm by using the plasma torch. Hence the author considers that the latter method will be more economical.

The plasma torch has been used for applying protective coatings to various metallic surfaces, including those applied to the internal surfaces of liquid rocket engines.

The plasma torch has been used successfully for applying many

inorganic materials which melt without decomposition. Thus, for example, those which fuse on readily are:

- a) high-melting metals - tungsten, rhenium, tantalum, molybdenum and niobium;
- b) certain high-melting compounds - borides of zirconium, tungsten, niobium, tantalum, titanium and chromium;
- c) high-melting carbides - carbides of niobium, hafnium, tantalum, zirconium, titanium, tungsten and vanadium;
- d) refractory oxides - thorium dioxide, hafnium dioxide, magnesium oxide, zirconium dioxide, cerium dioxide and aluminum oxide;
- e) precious metals - platinum, palladium and the platinum-group metals, as well as alloys based on them.

The feasibility of fusing tungsten onto a product composed of low-melting metals, for example, of bronze, aluminum and other metals, is of particular interest. Thus, for example, by fusing tungsten onto a bronze core and then dissolving the core material in an acid, we may succeed in obtaining a thin-walled product of complex shape. The tungsten obtained after such building-up has a density of from 94 to 95%; however, additional annealing at 1400° increases its density to 97-98% of theoretical.

Figure 13 illustrates the fusion of tungsten onto the nose cone of a missile.

Buckle [34] used high-melting oxides, precious metals and their alloys for the protection of niobium. The following methods of applying protective coatings were tested.

Fusion. In this method, a layer of either platinum or platinum group metals was applied with a thickness of 20 mu. Generally, a paste containing platinum chloride, which decomposes on tempering with liberation of metallic niobium, is applied to a coated surface. The

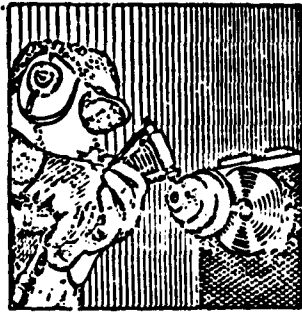

Fig. 13. Fusion of tungsten powder onto nose of missile [31].

resultant platinum layer adheres firmly to the niobium and possesses high protective properties.*

Vaporization. Sublimation of the protective material and its subsequent condensation onto the surface of niobium objects is the basis of the method. Aluminum oxide applied by this method was found to be very brittle, was readily detached from the surface and did

not provide niobium with protection from oxidation. A layer of thorium dioxide with a thickness of several millimeters applied by vaporization in a vacuum between 2700 and 3000° also failed to prevent the formation of scale on niobium when it was heated.

Baking-in. The essence of this method consists in cold application of a coating, usually composed of high-melting oxides, and baking it onto the surface of niobium objects by firing. In the heating process, the coating is not brought up to the melting point. Adhesion of the oxides to the niobium surface was strengthened sharply by the introduction of a mixture of metal and oxide powders into the boundary layer enclosed between the baked-in oxides and the surface of the coated object. Coatings of aluminum oxide, thorium dioxide and silicon dioxide may be produced by roasting the oxide-metallic mixtures at 1700 to 2000°.

Sintering of object made of metallic powder with protective oxide layer applied to object. In this method, a layer consisting of either aluminum oxide, thorium dioxide or a mixture of the two was applied to niobium. A layer of oxides was pressed onto an unroasted compact of niobium powder, which was then subjected to firing in a vacuum at 1700 to 2000°. The oxide layer adhered firmly to the niobium, but did

not protect it from oxidation - breakdown began in an atmosphere of air at 1250° in only 10 to 20 minutes. It is possible to obtain a protective layer which does not separate from niobium on severe mechanical pounding by pressing layers composed of a powdered mixture of metal and oxide [27] onto the surface of the specimen and subsequent roasting.

Consolidation of scale by roasting in a vacuum. Niobium specimens that had been oxidized in an atmosphere of air at 1250° over a period of 20 minutes were heated in a vacuum at 1700 to 2000° for the purpose of obtaining a consolidated layer of scale. It was found here that the oxide layer was not consolidated. The introduction of thorium and niobium additives to obtain a dense scale consisting of the mixed oxides also produced a negative result.

Chemical treatment. It was shown that when tungsten is treated with either hydrofluoric acid or chlorides of alkali metals, for example, on immersion of tungsten in a sodium chloride solution, a layer which sharply reduces the rate of scale formation is formed on the surface of the metal. Because of the relatively low melting point of tungsten trioxide (1473°), the protective nature of this layer was apparent only up to 1400°. Protective properties can be restored by repeated chloride treatment at certain time intervals.

The methods investigated by Buckle for the application of coatings do not guarantee reliable protection of niobium from high-temperature gas corrosion. Nevertheless, their testing was definitely useful. Among other things, it was shown that to increase the adherence strength of the oxide coating to niobium, we must apply a mixture consisting of metal and oxide powders as an intermediate layer.

Miller [3, page 517] notes that protective metallic coatings applied by the gas-flame spraying method are apparently of little effect.

The results of detailed study of the mechanics of the protective coatings applied by a gas-flame sprayer on molybdenum are the basis for this supposition. However, Wlodek's study [29] of a number of the most recent investigations shows that the gas-flame spraying method, like the method of spraying with a plasma torch, is highly promising. To all appearances, when evaluating the methods under consideration, we should consider the composition of the metallic and cerametallic coatings. In the same report, Miller notes that various high-melting oxides were applied to niobium by the gas-flame spraying method. However, the results of systematic investigation of these coatings were not published.

CERTAIN PREREQUISITES FOR THE FORMATION OF HIGH-TEMPERATURE CORROSION RESISTANT NIOBIUM ALLOYS

Studies are frequently encountered in the literature in which attempts to prevent high-temperature gas corrosion of niobium by metallurgical means - by the formation of niobium-based alloys which resist oxidation - are set forth.

Goldschmidt [35] points out that a gas-tight oxide film may be obtained on the surface of niobium alloys by the following means:

by stabilization of niobium pentoxide; this enables us to strengthen the adherence of the oxide film to the base;

by forming the lower niobium oxides, which have a tendency to form stable compounds of variable composition with other oxides (for example, niobium dioxide - titanium dioxide solid solutions);

by the formation of a vitreous layer.

Niobium pentoxide may be stabilized either by converting it into double oxides (Table 5) or by dissolving the oxides of the alloying elements in it. The feasibility of forming solid solutions on the basis of niobium pentoxide, as well as the diffusion mobility of the ions

that enter into the composition of the dissolving oxides, will be determined by the valence and dimensions of the above ions (Table 11).

On the basis of data from certain investigations, Miller assumes [3, page 518] that when oxides containing ions with a valence greater than that of niobium (>5) are dissolved in niobium pentoxide, we should anticipate a drop in the rate of ion diffusion through the scale layers and in the oxidation rate. Solution of oxides containing ions with valences less than 5 may give rise to the opposite effect – an increase in the diffusion rate – and therefore an increase in the oxidation rate of the niobium alloy. On this basis, we should expect addition of molybdenum and tungsten to increase, and addition of titanium and zirconium, taken either individually or combined, to reduce the resistance of the niobium alloys to oxidation.

TABLE 11
Properties of Alloying Elements and Their Oxides

1 Элемент	2 Валентность	3 Полный радиус по Гольдшмидту, Å	4 Отрицательное значение свободной энергии образования оксида при 1300° K, ккал·г-моль ⁻¹	5 Температура плавления оксида, °C	6 Отношение молярного объема оксида к атомному объему металла
Mn	2	0.80	69.3	1790	1.79
Zr	4	0.79	101.4	2715	1.56
Co	2	0.72	33.3	1810	1.86
Ni	2	0.69	28.6	1960	1.65
Nb	5	0.69	63.9	1460	2.69
Ta	5	0.68	70.8	> 1900	2.54
Ti	4	0.68	84.8	1860	1.73
Fe	3	0.64	39.0	—	2.14
Cr	3	0.63	63.6	2440	2.07
Mo	6	0.62	35.5	795	3.24
W	6	0.62	41.3	1470	3.35
V	5	0.59	49.6	660	3.19
Al	3	0.51	100.3	2020	1.49
Si	4	0.42	77.2	1713	2.21

1) Element; 2) valence; 3) Goldschmidt's ionic radius, Å; 4) negative value of free energy of formation of oxide at 1300° K, kilogram-calories·gram-molecule⁻¹; 5) melting point of oxide, °C; 6) ratio of molecular volume of oxide to atomic volume of metal.

When analyzing the problem of the influence of the ionic dimen-

sions on the ability of the oxide layer to resist further development of corrosion, we should consider that there are no defects in the cation part of the niobium pentoxide crystal lattice. Therefore, the solution of other oxides in niobium pentoxide is made possible only by replacement of the niobium ions in the Nb_2O_5 lattice by the ions of alloying elements. We may expect that the replacement of the niobium ions by ions possessing smaller effective radii will lead to a reduction in size of the elementary niobium pentoxide cell. This, in turn, decreases the ratio of the molar volume of the oxide to the atomic volume of the metal, enables us to obtain a denser film of niobium pentoxide, prevents the possibility of cracks forming in the film and increases the protective properties of the scale. Following these considerations and using the data from Table 11, we may expect that the alloying of niobium with either molybdenum or vanadium will increase the resistance of a niobium alloy to oxidation. However, the application of zirconium for these purposes does not exert a similar influence upon high-temperature corrosion resistance because the size of the Zr^{4+} ion is larger than the radius of the Nb^{5+} ion.

The free oxides of the alloying elements form in the oxide film on attainment of saturation in the niobium pentoxide type of solid solution. The appearance of new crystal phases in the scale increases the oxidation rate of niobium, chiefly as a result of boundary diffusion of the metal and gas atoms. The protective properties of the oxide, however, will be determined largely by the nature of the phases that arise. The increase in thermodynamic stability, the rise in melting point, the elimination of polymorphic transformations and the decrease in molecular volume of the free oxides developed in the corrosion process will contribute to improvement of the protective properties of the oxide layer. The influence of the individual alloying

additives on the oxidizability of the binary niobium alloys is shown in Figs. 14 and 15.

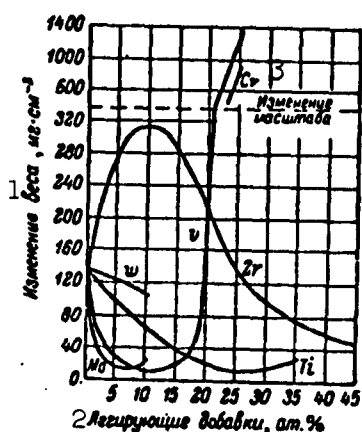

Fig. 14. Change in weight of niobium alloys after heating at 1000° for 5 hours in an atmosphere of air [36].

1) Weight change, $\text{mg}\cdot\text{cm}^{-2}$; 2) alloying additives, atom-%; 3) break in scale.

The resistance of the binary niobium alloys to oxidation is dependent not only upon the alloying element, but also upon its content in the alloy [36].

Vanadium. Investigations have shown that

- the oxidizability minimum of alloys with 12.5 atom-% of vanadium is observed at 1000° , while it is observed at 1200° with 10 atom-% of vanadium. Niobium alloys with a higher vanadium content are inclined to rapid oxidation; this is due to the transition of vanadium pentoxide into the liquid state (V_2O_5 melts at 660°) and to surface melting of the oxide film.

Molybdenum. Alloys with 7.5 atom-% of molybdenum have minimum oxidizability at 1000° , while this occurs at 1200° for alloys with 10 atom-% of molybdenum. The influence of the size of the ion upon the increase in the oxidation resistance of the niobium-molybdenum alloy is more strongly manifested than that of the valence of the molybdenum ion. Where the molybdenum content is above 10 atom-%, intensive oxidation of the alloy is observed; this is caused by the appearance of a liquid phase (MoO_3 melts at 795°) and by the oxidation of the scale.

Tungsten. Tungsten additives reduce the oxidizability of niobium very little at 1000° , but when the temperature is increased to 1200° they stabilize niobium pentoxide and become more effective. Therefore, the influence of the size of the tungsten ion on the oxidizability of the alloys begins to appear only at 1200° .

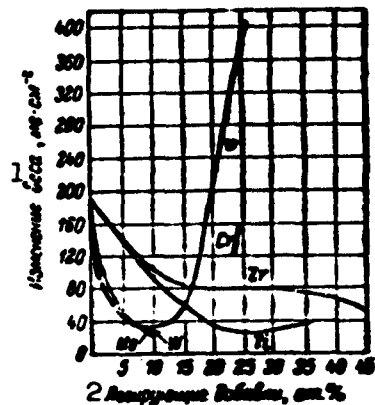

Fig. 15. Weight change of niobium alloys after heating at 1200° for 2 hours in air atmosphere [36].
 1) Weight change, $\text{mg} \cdot \text{cm}^{-2}$; 2) alloying additives, atom-%.

Chromium. According to certain data [37], additives of 15 atom-% of chromium reduce the oxidizability of niobium alloy somewhat at 1200°. However, the oxidizability increases with a higher chromium content in the alloy. The presence of chromium oxide in the scale increases the diffusion mobility of the atoms; this is apparently a result of the volatility of the chromium oxide at temperatures above 1200°.

Titanium. Addition of small quantities of titanium to niobium exert a relatively small influence on the oxidizability of

niobium-titanium alloy. An alloy containing 25 atom-% of titanium has the greatest resistance against oxidation at temperatures from 1000 to 1200°. A decrease in the oxidizability of the niobium-titanium alloy of the above composition is most likely due to the formation of stable double oxides – titanium niobates – in the oxide layer (Table 5).

Zirconium. Small additives of zirconium (up to 10 atom-%) increase the oxidizability of the niobium-zirconium alloys at 1000° and reduce it at 1200°. The introduction of zirconium into the alloys in quantities that exceed 25 atom-% enables us to reduce the oxidizability of the alloys. Where the zirconium content in the alloy is 25 atom-% and greater, a stable zirconium niobate of the composition $6\text{ZrO}_2 \cdot \text{Nb}_2\text{O}_5$ forms in the scale and subsequent oxidation of the alloy takes place parabolically.

The influence of aluminum, boron and titanium additives on the oxidation resistance of niobium alloys at high temperatures has also been studied [38]. The authors measured the oxidation rate, expressing

it in $\text{mg}\cdot\text{cm}^{-2}\cdot\text{hour}^{-1}$, and, using data from x-ray analysis, determined the phase composition of the scale formed on the surface of the alloy. It was established that the oxidation rate decreases with increasing content of the alloying element in alloys of niobium with aluminum. Addition of aluminum in an amount of 1-2 atom-% has virtually no effect on the structure of the scale, while on introduction of 5 atom-% of aluminum into the alloy, the scale becomes denser and the diffusion rate of oxygen decreases. A further increase in the aluminum content in the alloy to 15 atom-% alters neither the structure of the scale nor the oxidation rate of the alloys. A certain decrease in the oxidation rate is observed on alloying of niobium with 0.5-3 atom-% of boron. In niobium-tantalum alloys the lowest oxidizability occurs when there is 10 atom-% of tantalum.

Thus, under certain conditions, the alloying of niobium with vanadium, molybdenum, tungsten, chromium, titanium, zirconium and aluminum noticeably reduces, but does not altogether eliminate the oxidizability of the binary niobium alloys when they are heated in an atmosphere of air. At present, research into the multicomponent niobium alloys is being conducted. It is possible that the simultaneous alloying of niobium with several elements will enable us to obtain alloys whose resistances to oxidation will be greater than those of the binary alloys. Even now, niobium alloys have been obtained which possess extraordinary resistances to oxidation at a temperature of 1230° , and, projecting, we may anticipate that still higher-quality alloys will be developed [4, page 61].

CONCLUSIONS

The data given above show that in many cases, the measures proposed thus far insure effective protection of niobium from high-temperature gas corrosion. The methods studied above for the protection

of niobium satisfy the specifications for both temperature level (not less than 1150°) and duration of service (not less than 100 hours) only in a static atmosphere of air. The search for means of protecting niobium from oxidation in a medium of hot gases has taken two directions: creation of alloys based on niobium that are resistant to oxidation, and by development of protective surface coatings which insulate the metal from the gaseous medium.

Studies completed up to the present time have shown that the alloying of niobium with various elements decreases, but does not fully prevent oxidation of the niobium alloys. A few studies conducted for the purpose of finding effective protective surface coatings are indicative of the great difficulty, but fundamental possibility of preventing oxidation of niobium in a medium of hot gases. The difficulties encountered in the search for protective coatings are governed by the properties of the scale which forms on niobium when it is heated in a medium of gaseous oxidizing agents. As we noted earlier, the molecular volume of niobium pentoxide, which is the fundamental component of the scale, is greater than the corresponding atomic volume of niobium by a factor of 2.69. Moreover, when heated to temperatures above 800° , niobium pentoxide undergoes polymorphic transformations which are accompanied by a change in the specific volume and loosening of the scale; this facilitates admission of gaseous oxidizing agents to the surface of the metal.

The protective metallic coatings were found to be highly effective in use of niobium at temperatures up to 1000° . Chrome-plating by the thermodiffusion-saturation method of galvanization by immersion and subsequent homogenizing will insure protection of niobium from oxidation in a static atmosphere of air at 980° over a period of 300 to 320 hours. A characteristic feature of the zinc coatings is their

tendency to "self-heal" occasional defects which arise either in the treatment process or in operation with the objects. In addition to this, adequately effective protection may be obtained by applying either platinum or platinum-group metals to niobium. The opportunities for practical use of these coatings are limited, however, by their high cost.

In the temperature range from 1000 to 1150°, uses may be found for the mixed coatings whose compositions incorporate high-melting oxides and metals. In the heat-treatment process, the metals introduced into the coating are oxidized and form a continuous layer consisting of complex oxides that are stable to high temperatures. These composite coatings show moderate brittleness both cold and hot and may be used in certain cases for protection of products which are subjected to dynamic loading. The resilience of these composite coatings is determined by the nature and quantity of the metallic component present in them. A composition typical for these coatings would be aluminum oxide, thorium dioxide and metallic niobium.

Coatings of various high-melting materials applied with a plasma torch may be used for temperatures exceeding 1150°. We should emphasize, however, that special and, moreover, extremely careful preparation of the surfaces of the coated objects is necessary in this case to produce coatings which adhere tenaciously to the surface of the niobium objects. Apparently, we may consider that the fundamental factor governing firm adherence of the protective layer to niobium is a mechanical force the magnitude of which is a direct function of the degree of roughness, form, dimensions, etc., of the metallic surface. The chemical bonding forces which are responsible for the high adherence strength of the coatings applied by the fusion method are of incomparably lesser importance than the mechanical forces, since on

dusting of the coatings with the plasma torch, the surfaces of the objects to be coated are heated to temperatures of 200 to 250°. In this range, chemical reaction between the niobium and the coating is practically nonexistent. Coatings used at this temperature level are typical cerametallic materials consisting of high-melting molybdenum and chromium silicides alloyed with boron and aluminum, as well as metallic Nb-Ti-Cr alloys which are alloyed with vanadium, iron, nickel and aluminum.

It is expedient to conduct further studies in the search for effective means for protecting niobium from high-temperature gas corrosion in the following directions.

1. It is necessary to subject the metal-ceramic protective coatings obtained by spraying on mixed powders of certain metals and silicon to a detailed study. After fusing on, high-temperature corrosion resistant silicides of the corresponding metals form in the coatings and protect the niobium from corrosion.

2. Interest is drawn to systematic investigation of mixed coatings consisting of a vitreous cement and metallic fillers. Compositions containing niobium should be studied where coatings intended for prolonged operation are to be developed. The presence of niobium in the composition of the composite coatings noticeably increases their durability.

3. We should also study the properties of the multilayered protective coatings, using the most characteristic properties of each layer in turn. Thus, for example, to guarantee the best adherence to niobium, it is expedient to apply a metallic thermodiffusion layer; then, in order to increase erosion resistance and dependability, to build up a layer of a composite coating, and apply a third layer by the methods of solution ceramics [39] to obtain a smooth surface. This

method of protecting niobium from high-temperature gas corrosion is highly promising.

4. A search for cold methods of protecting niobium from oxidation in an atmosphere of hot gases should occupy a special position in future studies. These methods are of prime significance for a whole series of ramifications of contemporary technology, which employ various sheet-material structures.

5. We should conduct a more vigorous search for multicomponent high-temperature corrosion resistant niobium alloys.

Manu-
script
Page
No.

[Footnotes]

- 16 Kubaschewski and Schneider determined the oxidation resistance from the pressure drop occurring with the reaction of the Cr-Nb alloys with oxygen when the specimens were heated in a sealed tube filled with air.
- 20 A mixture of propane, butane and oxygen is burned in the explosive-charge gun, while acetylene and oxygen are burned in the gas-flame sprayer. Replacement of the acetylene by the propane-butane mixture enables us to use greater pressures, as a result of which intense hydrocarbon combustion is achieved and the motion of the particles of sprayed material with supersonic velocity is assured.
- 29 Wlodek's conclusion regarding the volatility of SiO at 1550° does not agree with the experimental data of Fitzer and Rubisch [30], who showed that the presence of a vitreous protective film on the surface of molybdenum disilicide is dependent upon the diffusion of silicon oxide (SiO) through the silicon dioxide even at temperatures above 1550°.
- 30 According to Wlodek's data, niobium pentoxide melts at 1450°.
- 33 The amount of heat introduced by the source into the body being heated is implied by the term "effective heat output."
- 37 The author does not cite specific data regarding the high-temperature corrosion resistance of the platinum coatings.

REFERENCES

1. H. Buckle. Les alliages de molybdene et leur protection contre l'oxydation [Molybdenum Alloys and Their Protection Against Oxidation], La Recherche Aeronautique [Aeronautical Research], No. 61, 1957, page 47.
2. V. Espe and M. Knol', Tekhnologiya elektrovakumnykh materialov [Technology of Electrovacuum Materials], translated from the German; edited by E.Yu. Kleyner, Oborongiz [State Publishing House for Literature of the Defense Industry], Moscow-Leningrad, 1939.
3. G.L. Miller. Tantalum and Niobium. Butterworth scientific publications. London, 1959.
4. Niobiy i tantal [Niobium and Tantalum], collection of papers edited by O.P. Kolchin, Izd. IL [Foreign Literature Press], Moscow, 1960.
5. D.V. Ignatov and R.D. Shamgunova, O mekhanizme okisleniya splavov na osnove nikelya i khroma [Oxidation Mechanism of Alloys Based on Nickel and Chromium], Izd. AN SSSR [Publishing House of the Academy of Sciences USSR], Moscow, 1960.
6. G.M. Gordon, J.W. Spretnak and R. Speiser. Oxidation resistance of niobium-zirconium-titanium alloy. Transact. AIME, 212, 1958, page 659.
7. P. Slavinskiy, Fiziko-khimicheskiye svoystva elementov [Physico-chemical properties of the elements], Metallurgizdat [State Publishing House for Literature on Metallurgy], Moscow, 1952.
8. C.W. Balke. Corrosion Handbook. Ed. H.H. Uhlig, J. Willey, N.Y.; Chapman and Hall, L., 1948.
9. E.A. Gulbransen and K.F. Andrew. Kinetics of reactions of columbium and tantalum with O_2 , N_2 and H_2 . Journ. of Metals, 180, 1950,

page 586.

10. D.W. Klopp, C.T. Sims and R.I. Jaffee. High temperature oxidation and contamination of niobium. *Transact. Amer. Soc. Metals*, 51, 1959, page 293.
11. G.V. Samsonov and V.I. Konstantinov, Tantal i niobiy [Tantalum and Niobium], Metallurgizdat, Moscow, 1959.
12. M.W. Shafer and R. Roy. The polymorphism of Nb_2O_5 . *Zeitschr. fuer Kristallogr. [Journal for Crystallography]*, Vol. 110, No. 3, 1958, page 241.
13. A.N. Krestovnikov and A.S. Shakhov, Termodinamicheskiye i fiziko-khimicheskiye svoystva redkikh metallov [Thermodynamic and Physico-chemical Properties of Rare Metals], Moscow-Leningrad, 1939.
14. O.A. Songina, Redkiye metally [Rare Metals], Metallurgizdat, Moscow, 1955.
15. A.U. Seibolt. Solid solubility of oxygen in columbium. *Journ. of Metals*, v. 6, No. 6, 1954, page 774.
16. A.I. Borisenko, Zashchita molibdena ot vysokotemperaturnoy gazovoy korozii [Protection of Molybdenum From High-Temperature Gas Corrosion], Izd. AN SSSR, Moscow-Leningrad, 1960.
17. A. Reisman, F. Holtzberg and E. Banks. Heterogeneous equilibria in the system Na_2O or $Na_2CO_3 - Nb_2O_5$. *Journ. Amer. Chem. Soc.*, v. 80, No. 1, 1958, page 37.
18. A. Reisman and F. Holtzberg. Phase equilibria in the system $K_2CO_3 - Nb_2O_5$ by the method of differential thermal analysis. *Journ. Amer. Chem. Soc.*, v. 77, No. 8, 1955, page 2115.
19. R.S. Roth and L.W. Coughanour. Phase equilibrium relations in the system titania-niobia and zirconia-niobia. *Journ. of Research NBS*, v. 55, No. 4, 1955, page 209.
20. V.I. Spitsyn, L.I. Komissarova, Z.A. Vladimorova, Yu. P. Simanov

- and N.N. Tyutyuyeva, Niobat i tantalat tsirkoniya [Zirconium Niobate and Tantalate], DAN SSSR [Proceedings of the Academy of Sciences USSR], Vol. 131, No. 4, 1960, page 857.
21. M.H. Francombe. The relation between structure and Ferroelectricity in lead-barium and barium-strontium niobates. Acta Crystallographica, v. 13, No. 2, 1960, page 131.
 22. R.S. Roth. Phase equilibria in the system cadmium oxide-niobium oxide. Journ. Amer. Cer. Soc., v. 44, No. 1, 1961, page 49.
 23. A.I. Komkov, Rentgenovskoye issledovaniye iskusstvennykh redkozemel'nykh soyedineniy tipa TRNbO₄ [X-Ray Investigation of Synthetic Rare-Earth Compounds of the TRNbO₄ Type], DAN SSSR, Vol. 126, No. 4, 1959, page 853.
 24. O. Kubaschewski and A. Schneider. Measurements on the oxidation-resistance of high-melting-point alloys. The Journ. of the Inst. of Metals, v. 16 (75), 1949, page 403.
 25. Chromizing makes molybdenum usable above 2000° F. Materials in Design Engineering, v. 47, No. 2, 1958, page 157.
 26. G. Sandos. Coating columbium for high temperatures. Journal of Metals, v. 12, No. 4, 1960, page 340.
 27. D.M. Dovey and K.C. Randle. Protective coatings on metals. Increase life at high temperatures. Metal Treatment, v. 20, No. 95, 1953, page 341.
 28. S. Chester. Oxidation behavior and protection of refractory metals, Corrosion, v. 16, No. 4, 1960, page 129.
 29. S.T. Wlodek. Coatings for columbium. Journ. Electrochem. Soc., v. 108, No. 2, 1961, page 67.
 30. E. Fitzer and O. Rubisch. Molybdaensilzid als Heizleiterwerkstoff [Molybdenum Silicide as a Heat-Conducting Material], Elektrowaerme [Electric Heat], No. 5, 1958, page 163.

31. P. Fossen. New plasma tools handle ultrahard metals. *Missiles and Rockets*, v. 4, No. 25, 1958, page 26.
32. 30,000 degrees with the plasma jet. *Journ. of Metals*, v. 11, No. 1, 1959.
33. I.D. Kulagin and A.V. Nikolayev, *Primeneniye dugovogo ionizirovannogo potoka elektricheskoy dugi dlya nagreva materialov* [Use of Arc Ionized Flux of Electric Arc for Heating of Materials], *Izv. AN SSSR, Otdel. tekhnich. nauk, Metallurgiya i toplivo* [Bulletin of the Academy of Sciences, USSR, Division of Technical Sciences, Metallurgy and Fuel], No. 2, 1959, page 78.
34. H. Buckle. *Das Diffusionsverhalten von Edelmetallplattierungen* [The Diffusion Behavior of Noble Metal Platings], *Zeitschr. f. Metallkunde* [Journal for Metallurgy], Vol. 37, Nos. 1-2, 1946, page 81.
35. H.J. Goldschmidt. A high temperature x-ray investigation of Nb_2O_5 . *Journ. Inst. Metals*, 87, 1958-59, page 235.
36. C.T. Sims, W.D. Klopp and R.I. Jaffee. Studies of the oxidation and contamination resistance of binary niobium alloys. *Trans. Amer. Soc. Metals*, 51, 1959, page 263.
37. C. Wagner. The formation of composite scales consisting of oxides of different metals. *Journ. Electrochem. Soc.*, v. 103, No. 10, 1956, page 571.
38. D.A. Prokoshkin and Ye.V. Vasil'yeva, *K voprosu ob okislenii nekotorykh dvoynykh splavov na osnove niobiya* [Concerning the Problem of Oxidation of Certain Binary Alloys Based on Niobium], *Sb. nauchnykh dokladov po teorii zharoprochnosti* [Collected Scientific Papers on the Theory of High-Temperature Strength], *Izd. AN SSSR, Moscow*, 1961, page 192.
39. A.I. Borisenko, *Tonkosloynnye emali* [Thin-Layered Enamels],

Gosstroyizdat [State Publishing House for Literature on Construction and Structural Materials], Leningrad, 1958.

DISTRIBUTION LIST

DEPARTMENT OF DEFENSE	Nr. Copies	MAJOR AIR COMMANDS	Nr. Copies
		AFSC	
		SCFDD	1
		ASTIA	25
HEADQUARTERS USAF		TDHFL	5
		TDEDP	5
AFCIN-3D2	1	AEDC (AEY)	1
ARL (ARB)	1	TDBX	1
 OTHER AGENCIES			
CIA	1		
NSA	6		
DIA	9		
AID	2		
OTS	2		
AEC	2		
PWS	1		
NASA	1		
ARMY	3		
NAVY	3		
SPECTRUM	1		
RAND	1		