

UNCLASSIFIED

AD

299 675

*Reproduced
by the*

**ARMED SERVICES TECHNICAL INFORMATION AGENCY
ARLINGTON HALL STATION
ARLINGTON 12, VIRGINIA**



UNCLASSIFIED

NOTICE: When government or other drawings, specifications or other data are used for any purpose other than in connection with a definitely related government procurement operation, the U. S. Government thereby incurs no responsibility, nor any obligation whatsoever; and the fact that the Government may have formulated, furnished, or in any way supplied the said drawings, specifications, or other data is not to be regarded by implication or otherwise as in any manner licensing the holder or any other person or corporation, or conveying any rights or permission to manufacture, use or sell any patented invention that may in any way be related thereto.

63-3-1

FTD-TT- 62-1230

CATALOGED BY ASTIA 299675
AS AD NO.

TRANSLATION

TESTING OF FLOATED GYROSCOPES

By

G. A. Sloryanskiy

FOREIGN TECHNOLOGY DIVISION

AIR FORCE SYSTEMS COMMAND

WRIGHT-PATTERSON AIR FORCE BASE

OHIO



ASTIA
RECEIVED
APR 8 1963
ASTIA

UNEDITED ROUGH DRAFT TRANSLATION

TESTING OF FLOATED GYROSCOPES

BY: G. A. Slomyanskiy

English Pages: 47

SOURCE: Russian Book, Voprosy Tekhnologii
Priborostroyeniya, Trudy Institut,
Aviatsionny Tekhnologicheskoy,
Nr. 40, Moskva 1959, pp 21-54.

S/536-59-0-40-1-5

THIS TRANSLATION IS A RENDITION OF THE ORIGINAL FOREIGN TEXT WITHOUT ANY ANALYTICAL OR EDITORIAL COMMENT. STATEMENTS OR THEORIES ADVOCATED OR IMPLIED ARE THOSE OF THE SOURCE AND DO NOT NECESSARILY REFLECT THE POSITION OR OPINION OF THE FOREIGN TECHNOLOGY DIVISION.

PREPARED BY:

TRANSLATION SERVICES BRANCH
FOREIGN TECHNOLOGY DIVISION
WP-APB, OHIO.

FTD-TT- 62-1230/1+2

Date 8 March 19 63

TESTING OF FLOATED GYROSCOPES

G.A. Slomyanskiy

Candidate of Technical Sciences

During recent years, reports have appeared in the foreign literature* on the operating principle and production of rotating apparatus for use in testing floated gyroscopes. These devices are single-axis integrators or integrating drives. The setting and sensing element in such an apparatus is the floated integrating gyroscope, which, as we know, can sense very low angular velocities.

A schematic diagram of a rotary device of the type under consideration is shown in Fig. 1. The device is installed on a base 3, which is fitted with the adjustable legs 15, and mounted on the massive pedestal 16. The housing 4 with the motor inside it is carried on the base 3 on the XX axis. The rotary platform 1, which is turned by the motor, is secured to the shaft 2, to which its plane is perpendicular. The XX axis and the shaft 2 must be rigorously perpendicular. The XX axis must be horizontal, and this is achieved by adjusting the heights of the feet 15.

The sector 13 with holes is secured to the housing 4. By inserting the positioning pin 14 in the appropriate hole in the sector 13, the shaft 2 can be set vertically, horizontally, or at a required angle to the horizontal (this method of giving the shaft 2 the required position is not the only possible one).

We shall henceforth assume that the shaft 2 is occupying its vertical position.

Cases in which it is necessary that the shaft 2 occupy some other position will be considered when we describe the drift testing of integrating gyroscopes at the end of this paper.

The apparatus is fitted with various devices for precision measurement of the angles and times of rotation of the platform 1 relative to the base 3. The device for measurement of the turn angles must have a sensitivity threshold of at most $1/600^\circ$.

The floated integrating gyroscope 5 and the gyroscope to be tested are set up on the platform 1 (in Fig. 1, the instrument to be tested is not shown). In drift tests of integrating gyroscopes and tests for performance in the spatial-integration mode, the gyroscope 5 is itself the instrument tested. In these cases, therefore, there is only the test instrument aboard the platform.

The figure axis of the gyroscope 5 will be denoted by \underline{z} and directed with the gyroscope's intrinsic moment H . We associate the rectangular coordinate system $Oxyz_0$ with the gyroscope housing. The x -axis is the axis of rotation of the gyroscope frame and is known as the instrument's output axis; the y axis is the input or, in other words, the measurement axis of the instrument; the z_0 -axis is perpendicular to the axes x and y and forms a right trihedron with them. The floated gyroscope must be mounted on the platform 1 in such a way that its input axis y will be placed colinear or parallel with the shaft 2 about which the platform rotates. By the conditions adopted, therefore, the y -axis will be directed vertically upward. The angle through which the gyroscope's figure axis deviates from the z_0 axis will be denoted by β . This angle is shown in the direction in which it is reckoned positive.

As we know, a floated integrating gyroscope has a pickup and a setter; the latter is sometimes known as the torque pickup. The

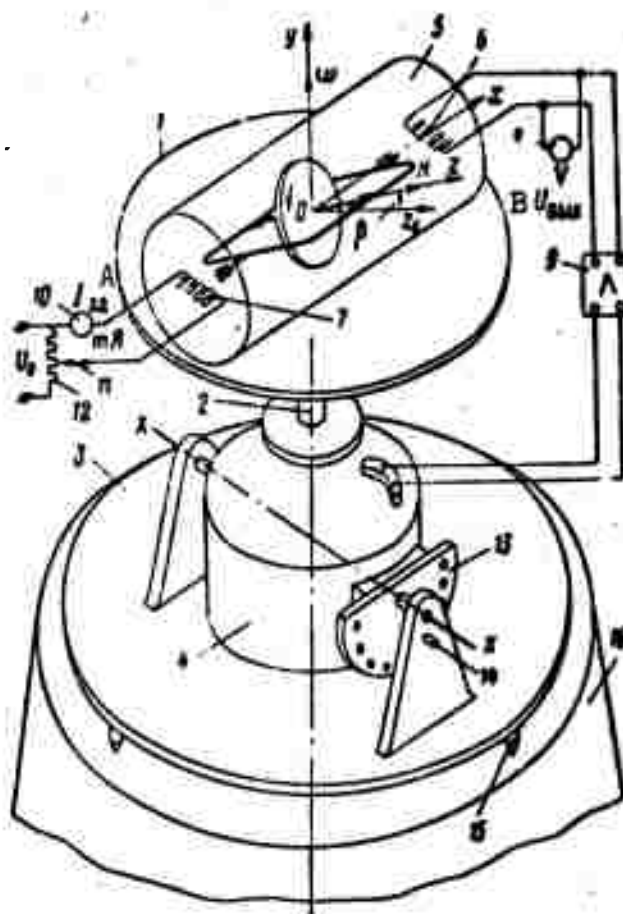

Fig. 1. Schematic diagram of rotary apparatus. 1) Rotary platform; 2) platform shaft; 3) base of apparatus; 4) housing with motor; 5) floated integrating gyroscope; 6) output winding of gyroscope pickup (represented schematically); 7) control winding of gyroscope setter (represented schematically); 8) voltmeter for measurement of voltage U_{vykh} ; 9) amplifier; 10) milliammeter for measurement of current I_{zd} ; 11) voltage-divider slide; 12) voltage divider; 13) perforated sector; 14) locating pin; 15) adjustable feet of base 3; 16) pedestal. A) I_{zd} ; B) U_{vykh} .

[angle] pickup has the function of producing an electrical signal in the form of a voltage U_{vykh} that is proportional to the angle β . This voltage is picked off its output winding 6 (represented schematically in Fig. 1). The function of the setter is to apply to the gyroscope (about its x axis) a torque M_{zd} proportional to the current I_{zd} de-

livered to the control winding 7 of the setter (this winding is also represented schematically in Fig. 1).

In this apparatus, the setter's secondary winding may be fed, for example, from the voltage divider 12. The required current value I_{zd} is set by moving the slide 11 and checking the milliammeter 10. The voltage U_{vykh} is fed to the input of the amplifier 9. The stator control winding of the motor in the housing 4 is connected to the amplifier output.

Now let us consider the operation of the apparatus. The apparatus must insure rotation of the platform 1 in inertial space about the y-axis with any constant absolute angular velocity ω from a small fraction of the Earth's rate of diurnal rotation ω_z to speeds of the order of 10-20 rad/sec. To set the platform 1 into rotation with the required absolute angular velocity ω , it is necessary to apply the corresponding current I_{zd} to the setter's control winding. Acted upon by this current, the setter applies to the gyroscope a torque (Fig. 2)

$$M_{zd} = K_{zd} I_{zd} \quad (1)$$

where $K_{zd} = \text{const}$ is the torque generated by the setter at a current $I_{zd} = 1 \text{ ma}$.

The direction of the torque M_{zd} is determined by the polarity or phase of the current I_{zd} (the setter may operate on either direct or alternating current). We shall consider a current I_{zd} to be positive if it sets up a positive moment M_{zd} , i.e., a moment directed along the positive axis x . Here and below, the torque vector will be directed along the appropriate axis in such a way that (viewed from the end) the rotation due to the torque is counterclockwise. We shall observe this same rule for the angular velocities and the gyroscope's intrinsic moment H .

The torque M_{zd} causes the gyroscope to rotate about the x-axis.

As a result, a voltage

$$U_{out} = K_{dt} \dot{\beta} \quad (2)$$

where $K_{dt} = \text{const}$ is the sensitivity of the pickup in v/rad , appears at the pickup output.

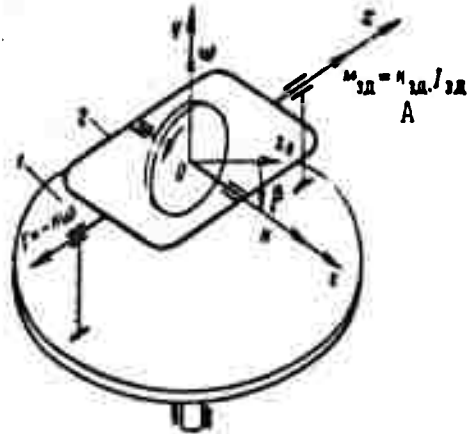

Fig. 2. Illustrating operation of rotary apparatus with current I_{zd} applied to control winding of setter.
1) Rotary platform; 2) floated integrating gyroscope.
A) $M_{zd} = K_{zd} I_{zd}$.

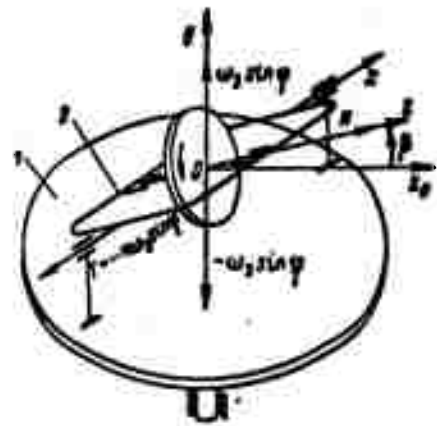

Fig. 3. Illustrating operation of rotary apparatus with $I_{zd} = 0$. 1) Rotary platform; 2) floated integrating gyroscope.

The voltage U_{vykh} is fed through the amplifier to the control winding of the motor (see Fig. 1). The motor begins to turn the shaft 2 with the platform 1. The direction of this rotation will be such that the torque produced by it (see Fig. 2)

$$\Gamma = -H\dot{\beta} \quad (3)$$

will oppose the torque M_{zd} .

The voltage U_{vykh} will always cause rotation of the motor in such a direction as to set up a gyroscopic moment G that tends to bring the gyroscope figure axis \underline{z} into coincidence with the z_0 -axis, i.e., to reduce the angle β to zero and thereby reduce the voltage U_{vykh} to zero. At the end of the transient response, which should occupy a very short time, the motor will be turning the platform with a constant absolute angular velocity ω at which the gyroscopic moment

G will be equal in magnitude to the moment M_{zd} , i.e. [see Expressions (3) and (1)],

$$H = K_m I_m.$$

From this, the platform's rate of rotation in the steady-state mode will be

$$\omega = \frac{K_m I_m}{H}. \quad (4)$$

Thus, a single absolute angular velocity ω of the platform will correspond to each value of the current I_{zd} .

In the steady-state mode, i.e., with $I_{zd} = \text{const}$ and, accordingly, $\omega = \text{const}$, the gyroscope figure axis \underline{z} will be inclined from the z_0 axis through a certain angle β^* necessary to produce the voltage U_{vykh} required to turn the platform at a velocity ω . For positive values of the current I_{zd} and, consequently, of the velocity ω , the angle β^* will be negative. Let us note that the parameters of the apparatus should be selected such that the angle β^* will be small for all possible values of the velocity ω , since otherwise the horizontal component of the angular velocity ω_z of the Earth's diurnal rotation will influence the performance of the device. It follows from the above reasoning that at $I_{zd} = 0$, the absolute rate of rotation of the platform about the y-axis must be zero. Let us demonstrate this (Fig. 3).

At $I_{zd} = 0$, the torque $M_{zd} = 0$. But since the apparatus is turning together with the Earth about the vertical in inertial space, or, in other words, about the y-axis at a velocity $\omega_z \sin \varphi$ (φ is the latitude at which the rotary apparatus is being used), a gyroscopic moment $-H\omega_z \sin \varphi$ will act about the x-axis and deflect the gyroscope figure axis \underline{z} away from the axis z_0 . As a result, a voltage U_{vykh} will appear at the pickup output and start the motor. The latter will begin

to turn (adjust) the platform 1 in a direction opposed to that of the velocity $\omega_z \sin \varphi$, i.e., clockwise, if we view it from the positive end of the y-axis.

At the end of the brief transient response, a mode in which the platform rotates with respect to the apparatus base at a velocity $-\omega_z \sin \varphi$ will have been established; only with such a relative platform speed will the gyroscopic moment acting about the x-axis be reduced to zero, since the absolute velocity ω of rotation of the platform about the y-axis will be zero.

In the apparatus under consideration, therefore, the rotation velocity of the platform in inertial space about the vertical (y-axis) will also be zero for $I_{zd} = 0$. The relative angular velocity of the platform, i.e., its velocity relative to the apparatus base (relative to the Earth) will in this case be $-\omega_z \sin \varphi$. For $I_{zd} \neq 0$, the relative angular velocity of the platform

$$\omega_{om} = \omega - \omega_z \sin \varphi = \frac{K_{zz}}{H} I_{zz} - \omega_z \sin \varphi. \quad (5)$$

The velocity ω_{otn} may be determined from measurement data for the angle and time of rotation of the platform about the y-axis relative to the apparatus base. Knowing ω_{otn} , we may determine the absolute angular velocity of the platform by the formula

$$\omega = \omega_{om} + \omega_z \sin \varphi. \quad (6)$$

Let us write the equation of motion of the platform about the y-axis. For this purpose, we shall first consider the equations of the individual elements of the rotary apparatus.

Floated integrating gyroscope. The following torques act upon the gyroscope in the general case as it rotates about the x-axis:

a) the gyroscopic moment determined by Equality (3), which, taking Expression (6) into account, assumes the form

$$\Gamma = -H(\omega_{\text{orn}} + \omega_3 \sin \varphi);$$

b) the damping moment

$$M_d = K_d \dot{\beta},$$

where K_d is the specific damping moment in g-cm-sec;

c) the moment M_{zd} , which is determined by Equality (1);

d) the moment of the inertial forces

$$M_j = J_g \ddot{\beta},$$

where J_g is the moment of inertia of the floated gyroassembly relative to the x-axis in g-cm-sec²;

e) the moment of friction in the supports of the floated gyroassembly $\pm M_t$ (the upper sign is taken for $\dot{\beta} > 0$ and the lower sign for $\dot{\beta} < 0$);

f) the torque due to imbalance of the floating gyroassembly, the reaction torques of the pickup and setter, the torques created by the current leads of the gyromotor, and other detrimental torques. All of these torques represent disturbances that interfere with normal performance of the instrument. Their sum, which must be small and, if possible, constant, will be denoted by M_p .

Equating the sum of the above torques to zero, we obtain the equation of motion of the gyroscope (floated gyroassembly) about the x-axis:

$$J_g \ddot{\beta} + K_d \dot{\beta} = H(\omega_{\text{orn}} + \omega_3 \sin \varphi) - K_{\text{on}} J_{\text{on}} \mp M_t - M_p.$$

Dividing this equation by K_d , we obtain

$$T_g \ddot{\beta} + \dot{\beta} = \frac{H}{K_d} (\omega_{\text{orn}} + \omega_3 \sin \varphi) - \frac{K_{\text{on}} J_{\text{on}}}{K_d} \mp \frac{M_t}{K_d} - \frac{M_p}{K_d}.$$

The quantity $T_g = J_g / K_d$ is the time constant of the integrating gyroscope. Since normally $T_g \approx 0.003$ sec, the term containing T_g may be disregarded in this last equation. Then, substituting Equality (2) into this equation after first differentiating it once with respect

to time, we obtain the equation of the floated integrating gyroscope:

$$\frac{K_s}{K_{st}} \dot{U}_{out} = H(\omega_{orn} + \omega_3 \sin \varphi) - K_{st} I_{st} \mp M_r - M_{st} \quad (7)$$

It was noted above that the moment M_p is the sum of moments governed by various causes. However, all components of this moment may be classified into two basic categories: systematic components $M_{p.sist}$ and accidental components $M_{p.sl}$. It is evident from Equation (7) that if a current

$$I_{st} = I_k = -\frac{M_{p.sist}}{K_{st}},$$

is fed to the secondary setter winding, the influence of $M_{p.sist}$ will be eliminated.

As concerns the moment $M_{p.sl}$, on the other hand, it cannot be compensated. This moment will cause a random drift of the rotary platform and, consequently, will be one of the most important factors determining the ultimate potential of the rotating-platform apparatus in the area of low angular velocities. As a result, a floated integrating gyroscope in which the frictional moment and the moment $M_{p.sl}$ are practically zero must be used in the rotary-platform apparatus. Let us assume that this requirement is satisfied and that the moment $M_{p.sist}$ is compensated by the current I_k .

Then Equation (7) for the floated integrating gyroscope assumes the following final form:

$$\frac{K_s}{K_{st}} \dot{U}_{out} = H(\omega_{orn} + \omega_3 \sin \varphi) - K_{st} I_{st} \quad (8)$$

Here, as earlier, I_{zd} designates the current fed to the control winding of the setter to turn the platform with the required speed. The compensation current I_k which is constantly fed to the same winding is not part of I_{zd} . The voltage U_{vykh} given by Equation (8) is fed to the amplifier input.

Amplifier. The amplifier components include a voltage amplifier,

a converter element, and a power amplifier. Assuming the voltage amplifier to be linear and lag-free, we find that its output voltage

$$U = K_1 U_{\text{vykh}} \quad (9)$$

where $K_1 = \text{const}$ is the gain of the voltage amplifier.

The function of the converter element is to convert the voltage U_{vykh} , or, what is the same thing, the voltage U in conformity with some desired functional relationship with the objective of assuring the required dynamic and static behavior of the system. As we know, the nature of the conversion effected by the converting element is determined by the control law adopted. In the rotary-platform device under consideration, it is expedient to effect control by the magnitude of the voltage U_{vykh} and its first time derivative \dot{U}_{vykh} . Introduction of the derivative into the control law will assist in shortening the transient-response time, i.e., reducing the time after which the platform will be rotating with a practically constant angular velocity ω after passage of the current I_{zd} .

Thus, we assume that the converter element converts the voltage U impressed upon its input into a voltage U_p that is proportional to U and \dot{U} . One or another of the correcting circuits used in servosystems to deliver alternating-current error signals (in our case, the voltage U_{vykh} or, what is the same thing, the voltage U) may be used as such a converting element. For such circuits, U_p may be expressed as follows as a function of U :

$$T_p \dot{U}_p + U_p = K_p (U + n T_p \dot{U}) \quad (10)$$

where $K_p = \text{const}$ is the gain of the converting element, T_p is the time constant, and n is a constant coefficient.

The converter-element output voltage U_p is fed to the power-amplifier input. At its output, we obtain a voltage (we assume the power amplifier to be linear and lag-free)

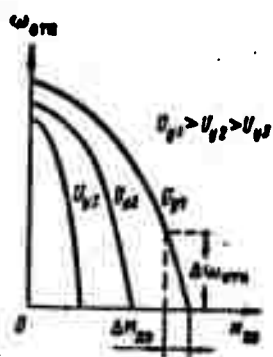

Fig. 4. Typical form of motor mechanical characteristics.

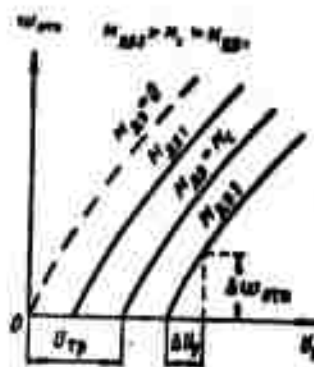

Fig. 5. Typical form of motor speed characteristics.

$$U_y = K_2 \dot{U}_u \quad (K_2 = \text{const}), \quad (11)$$

which is the output voltage of the entire amplifier. From Equations (9), (10) and (11), we obtain the over-all equation of the amplifier:

$$T_a \dot{U}_y + U_y = K_y (U_{0778} + n T_a \dot{U}_{0778}), \quad (12)$$

where

$$K_y = K_1 K_2 K_3 = \text{const}. \quad (13)$$

The voltage U_u is fed to the motor control winding and the motor sets the rotary platform turning.

Motor with platform. Let us assume that a two-phase induction motor with a high rotor resistance is employed in the apparatus. Use of an induction motor is advisable because without a collector and brushes it can begin turning at a pickup voltage lower than that for a direct-current motor — a very important point for attainment of platform rotation at very low angular velocities. Moreover, an induction motor requires an amplifier of lower power than a direct-current motor, since the major part of the power that it draws is taken directly from the line. An elevated rotor resistance is required so that the motor will have a "hard" characteristic and operate stably at low speeds.

The electromechanical time constant of the motor, which charac-

terizes its pickup process in the transient mode, is proportional (all other parameters the same) to its velocity in the steady-state mode. To reduce the electromechanical time constant, an attempt should be made to reduce the motor's speed in the steady-state mode by reducing its synchronous speed at the expense of increasing the number of pole pairs of the motor winding and the frequency of the power voltage.

The maximum steady-state speed of the motor used in the rotary-platform apparatus under consideration must be low. This makes it possible to have the motor multipolar and thereby produce a small electromechanical time constant. As concerns the power-voltage frequency, it should be equal to the frequency of the voltage fed to the excitation winding of the integrating gyroscope's pickup.

Let us assume that the mechanical and speed characteristics of the motor $\omega_{otn} = f(M_{dv})$ and $\omega_{otn} = f(U_u)$ take the forms shown in Figs. 4 and 5. For small values of ω_{otn} , these characteristics may be regarded as linear and it may be assumed that the motor torque

$$M_{dv} = -K_{dv1} K_{dv2} U_y - K_{dv3} \dot{\omega}_{otn} \quad (14)$$

where

$$K_{dv1} = \frac{\Delta M_{dv}}{\Delta \omega_{otn}} \quad (15)$$

is the "rigidity" of the motor's mechanical characteristic and

$$K_{dv2} = \frac{\Delta \omega_{otn}}{\Delta U_y} \quad (16)$$

In the range of low speeds, the coefficients K_{dv1} and K_{dv2} vary little. Consequently, they may be assumed constant and determined directly from the segments of the motor characteristics that correspond to low speeds.

The minus sign appears before the first term in the right member of Expression (14) for the following reasons. As was noted earlier, positive angular velocities of the platform must correspond to positive

currents I_{zd} . Consequently, for positive currents I_{zd} , the motor torque M_{dv} must also be positive. But with positive currents I_{zd} , the angle β will be negative; consequently, the voltage U_{vykh} will also be negative because its sign is the same as that of the angle β . [See Formula (2)]. Since the voltage U_{vykh} is an alternating voltage, its sign will be determined by its phase, which changes by 180° when the sign of the angle β changes. Let us assume that the phase of the voltage U_u is the same as the phase of the voltage U_{vykh} . Then negative voltages U_u will correspond to positive currents I_{zd} . Consequently, the sign of the moment M_{dv} must be opposite the sign of the voltage U_u , and this explains the minus sign in Expression (14) in front of the term containing U_u .

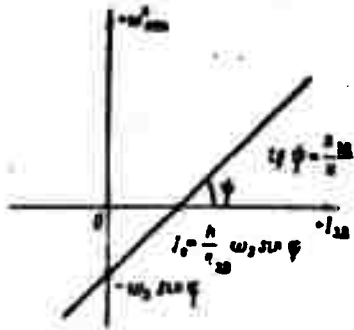

Fig. 6. Relative angular velocity of platform ω_{otn}^* as a function of current I_{zd} .

The equation of motion of the rotary platform about the y-axis (see Fig. 1) relative to the base of the device, i.e., relative to the Earth, may be written in the form

$$J \dot{\omega}_{otn} = M_{dv} \mp M_s \quad (17)$$

where J is the moment of inertia of the rotary platform with all devices mounted on it, as well as the rotating parts of the drive (see Fig. 1) relative to the y-axis and $M_s = \text{const}$ is the static moment of the rotary platform, i.e., the moment on the shaft 2 governed by friction in its bearings and in the contact rings mounted on it to supply power to the gyromotor, pickup and setter, feed the current I_{zd} , and pick up the voltage U_{vykh} .

Setting $M_s = \text{const}$, we disregard any of its possible small variations.

The minus sign should be taken before M_s in Equation (17) for

$\omega_{otn} > 0$ and the plus sign for $\omega_{otn} < 0$.

Substituting (14) in (17), we obtain the equation of the motor with the platform in the following form:

$$T_{22}\dot{\omega}_{otn} + \omega_{otn} = -K_{22}U_y \mp \frac{M_c}{K_{22}}, \quad (18)$$

where

$$T_{22} = \frac{J}{K_{22}} \quad (19)$$

is the electromechanical time constant of the motor with the platform.

Equations (8), (12) and (18) of the rotary-platform elements enable us to analyze both steady-state and transient modes of motion of the rotary platform. Let us first consider steady-state modes. The motion of the platform will be said to be steady-state if

$$I_{22} = \text{const}, \quad U_{22} = \text{const}, \quad U_y = \text{const}, \quad \omega_{otn} = \text{const}.$$

Then we obtain from Equations (8), (12) and (18) the following equations for the steady-state operating mode of the rotary apparatus:

$$H(\omega_{otn} + \omega_3 \sin \varphi) - K_{22}I_{22} = 0, \quad (20)$$

$$U_y = K_f U_{22}, \quad (21)$$

$$\omega_{otn} = -K_{22}U_y \mp \frac{M_c}{K_{22}}. \quad (22)$$

Let us consider the steady-state modes with $I_{zd} \neq 0$ and for $I_{zd} = 0$. The values of β , U_{vykh} , U_u and ω_{otn} in the steady-state mode will be denoted respectively by β^* , U_{vykh}^* , U_u^* , and ω_{otn}^* .

Steady-state modes with $I_{zd} \neq 0$. We have from Equation (20)

$$\omega_{otn}^* = \frac{K_{22}}{H} I_{22} - \omega_3 \sin \varphi = \frac{K_{22}}{H} (I_{22} - I_0), \quad (23)$$

where

$$I_0 = \frac{H}{K_{22}} \omega_3 \sin \varphi. \quad (24)$$

Thus, in the steady-state mode with $I_{zd} \neq 0$, the relative angular velocity ω_{otn}^* of the platform is a linear function of the current I_{zd} .

At $I_{zd} = I_*$, $\omega_{otn}^* = 0$. A curve of the velocity ω_{otn}^* as a function of the current I_{zd} is shown in Fig. 6.

Substituting (23) into Equation (22), we find that in the steady-state mode, the output voltage of the amplifier must be

$$U_y^* = -\frac{1}{K_{AB2}} \left(\frac{K_{AB1}}{H} I_{zd} - \omega_3 \sin \varphi \right) \mp U_{tr} = -\frac{K_{AB1}}{HK_{AB2}} (I_{zd} - I_0) \mp U_{tr} \quad (25)$$

where

$$U_{tr} = \frac{M_c}{K_{AB1} K_{AB2}} \quad (26)$$

is the pickup voltage of the motor loaded by the platform.

The voltage U_u^* may also be represented in the form

$$U_y^* = -\frac{\omega_{otn}^*}{K_{AB2}} \mp U_{tr} = -\frac{1}{K_{AB2}} \left(\omega_{otn}^* \pm \frac{M_c}{K_{AB1}} \right). \quad (27)$$

In Expressions (25), (27) and those that follow, the upper sign should be taken before the voltage U_{tr} and the moment M_c for $\omega_{otn}^* > 0$ and the lower sign for $\omega_{otn}^* < 0$. In the steady-state mode ($\omega_{otn} = \omega_{otn}^*$), the magnitude of the current I_{zd} may also be used as a guide in selecting the sign. For $I_{zd} > I_*$, the upper sign should be used, while the lower sign should be used when $I_{zd} < I_*$. We find from (2), (21) and (27) that

$$\beta^* = -\frac{1}{K_{AB1} K_y} \left(\frac{\omega_{otn}^*}{K_{AB2}} \pm U_{tr} \right) = -\frac{1}{K_{AB1} K_y K_{AB2}} \left(\omega_{otn}^* \pm \frac{M_c}{K_{AB1}} \right). \quad (28)$$

It follows from this that if the angle β^* may not exceed the maximum value $|\beta^*|_{max}$ at the highest possible absolute value of the velocity $|\omega_{otn}^*|_{max}$, the amplifier gain must be

$$\begin{aligned} K_y &= \frac{1}{K_{AB1} |\beta^*|_{max}} \left(\frac{|\omega_{otn}^*|_{max}}{K_{AB2}} + U_{tr} \right) = \\ &= \frac{1}{K_{AB1} K_{AB2} |\beta^*|_{max}} \left(|\omega_{otn}^*|_{max} + \frac{M_c}{K_{AB1}} \right). \end{aligned} \quad (29)$$

It is evident from this expression that the smaller $|\beta^*|_{max}$, the larger must be the amplifier gain, all other conditions the same. It is desirable to have $|\beta^*|_{max} < 0.001$.

The torque M_s , which should be reduced by all possible means, exerts a prime influence on the quantity K_u . The value of K_u diminishes with increasing K_{dt} , K_{dv1} and K_{dv2} .

We find from Equation (21) that the steady-state value of the voltage

$$U_{\text{out}} = \frac{U_y^*}{K_y}. \quad (30)$$

Steady-state mode with $I_{zd} = 0$. Setting the current $I_{zd} = 0$ in (23), we find that in this case the steady-state value of the platform's relative angular velocity

$$\omega_{\text{otn}}^* = -\omega_3 \sin \varphi, \quad (31)$$

i.e., the platform will turn relative to the base at a speed equal in magnitude and opposite in direction to the vertical component of the angular velocity of the Earth's diurnal rotation. Consequently, the absolute angular velocity ω with which the platform rotates about the vertical will be zero [see Equation (6)].

Substituting (31) in (27) and (28), and taking the minus sign before U_{tr} and M_s , since $\omega_{\text{otn}}^* < 0$, we obtain for $I_{zd} = 0$

$$U_y^* = \frac{\omega_3 \sin \varphi}{K_{\text{M2}}} + U_{\text{tr}} = \frac{1}{K_{\text{M2}}} \left(\omega_3 \sin \varphi + \frac{M_c}{K_{\text{M1}}} \right), \quad (32)$$

$$\beta^* = \frac{1}{K_{\text{st}} K_y} \left(\frac{\omega_3 \sin \varphi}{K_{\text{M2}}} + U_{\text{tr}} \right) = \frac{K_{\text{M1}} \omega_3 \sin \varphi + M_c}{K_{\text{st}} K_y K_{\text{M1}} K_{\text{M2}}}. \quad (33)$$

Transient response on instantaneous application of current $I_{zd} = \text{const}$ to setter control winding. In this case, the term transient response implies the time variation of the relative angular velocity of the rotary platform, during which the rotary platform passes from the stationary state into a state of steady rotation at a velocity ω_{otn}^* when the current $I_{zd} = \text{const}$ is applied momentarily to the integrating-gyroscope setter. Let us assume that at the point in time $t = 0$, when the current $I_{zd} = \text{const}$ is momentarily applied to the setter,

$\dot{\omega}_{otn} = \dot{\omega}_{otn} = 0$, $U_{vykh} = U_{Ovykh}$, $U_u = U_{Ou}$, where $|U_{Ou}| < U_{tr}$.

Due to the presence of the moment M_s , the rotation of the platform relative to the base may begin only when the amplifier output voltage is larger in absolute magnitude than the pickup voltage, i.e., when $|U_u| > U_{tr}$. Consequently, with the initial conditions that we have assumed, the transient response will consist of two stages.

During the first stage, the platform will remain stationary ($\dot{\omega}_{otn} = \dot{\omega}_{otn} = 0$). This stage will last until the amplifier output voltage has an absolute magnitude equal to that of the pickup voltage. The first stage will continue from $t = 0$ to $t = t_{tr}$. At $t = t_{tr}$, we shall have $|U_u| = U_{tr}$.

The second stage will begin at the moment when the platform begins to turn, i.e., at $t = t_{tr}$, and will continue until the state of steady rotation of the platform at a speed ω_{otn}^* has been reached.

Let us consider each of these stages of the transient response in isolation.

The behavior of the device's elements is characterized by Equations (8), (12) and (18). Substituting Expressions (23) and (26) into Equations (8) and (18), respectively, and assuming that the time constant T_p is sufficiently small to permit disregarding the term containing T_p in the left member of Equation (12), we obtain the equations of the rotary-apparatus elements in the form

$$\dot{U}_{ms} = K_u (\dot{\omega}_{otn} - \dot{\omega}_{otn}^*), \quad (34)$$

$$U_y = K_y (U_{ms} + n T_n \dot{U}_{ms}), \quad (35)$$

$$T_m \dot{\omega}_{otn} + \omega_{otn} = -K_{ms} (U_y \pm U_{tr}), \quad (36)$$

where

$$K_u = \frac{HK_{ms}}{K_s}. \quad (37)$$

The upper sign should be taken before U_{tr} with $\omega_{otn} > 0$, and the

lower sign with $\omega_{otn} < 0$.

Setting $\omega_{otn} = 0$ in Equation (34), we find that the system's behavior in the first stage of the transient response is described by Equations (35) and

$$\dot{U}_{out} = -K_u \dot{\omega}_{otn} \quad (38)$$

Integrating Equation (38) for the initial conditions ($U_{vykh} = U_{0vykh}$ at $t = 0$), we obtain

$$U_{out} = U_{0out} - K_u \omega_{otn} t \quad (39)$$

Consequently, the voltage U_{vykh} is a linear function of the time t in the first stage of the transient response.

Substituting (39) and (38) in (35), we obtain the variation of the voltage U_u during the first stage of the transient response:

$$U_y = -K_y [K_u \omega_{otn} (t + nT_p) - U_{0out}] \quad (40)$$

This voltage is also a linear function of the time t .

We find from (40) that the amplifier output voltage reaches the pickup voltage value after a time

$$t_{tr} = \frac{\pm U_{tr} + K_y U_{0out}}{K_y K_u \omega_{otn}} - nT_p \quad (41)$$

Here, the same sign should be used before U_{tr} as before the velocity ω_{otn}^* . Other conditions the same, the time t_{tr} will be smaller the smaller the voltage U_{tr} . The derivative signal, which governs the term nT_p in (41), shortens the time t_{tr} .

Let us denote by β_{tr} the absolute magnitude of the angle β at which the amplifier output voltage U_u becomes equal in absolute magnitude to the voltage U_{tr} . Setting the voltage U_u equal to U_{tr} in Equation (35) and substituting Equalities (2) and (38) in this equation, we obtain

$$\beta_{tr} = \frac{1}{K_x} \left(\frac{U_{tr}}{K_y} - nT_p K_u |\omega_{otn}^*| \right) \quad (42)$$

The angle β_{tr} will be smaller the smaller U_{tr} and the larger K_u and n .

At the time t_{tr} , i.e., at the end of the first stage and the beginning of the second stage of the transient response, we shall have

$$\text{for } \left. \begin{array}{l} U_y = \mp U_{yp} \\ \omega_{otn} = \dot{\omega}_{otn} = 0. \end{array} \right\} \quad (43)$$

Let us now pass to a consideration of the second transient-response stage. The initial conditions for this stage will be Conditions (43). During the second stage of the transient response, the behavior of the device's elements will be described by all three Equations (34), (35) and (36). Excluding U_{vykh} and U_u from these equations, we obtain a differential equation determining the variation of the angular velocity ω_{otn} in the second stage of the transient response:

$$\ddot{\omega}_{otn} + 2h\dot{\omega}_{otn} + v_0^2\omega_{otn} = v_0^2\omega_{otn}^* \quad (44)$$

where

$$v_0^2 = \frac{K_u K_y K_{as2}}{T_{as}} = \frac{HK_{st} K_y K_{as2}}{K_R T_{as}}; \quad (45)$$

$$h = \frac{1}{2} \left(\frac{1}{T_{as}} + v_0 T_s \right). \quad (46)$$

Let us assume that the parameters of the apparatus have been selected such that $h < v_0$. Then the solution of Equation (44) for the initial conditions (43) will take the following form:

$$\omega_{otn} = \omega_{otn}^* \left[1 - \frac{v_0}{v} e^{-ht} \sin(vt_1 + \theta) \right], \quad (47)$$

where

$$\left. \begin{array}{l} t_1 = t - t_{tr} \quad (t > t_{tr}), \\ v = \sqrt{v_0^2 - h^2}, \quad \operatorname{tg} \theta = \frac{v}{h}. \end{array} \right\} \quad (48)$$

Expression (47) indicates that during the second stage of the transient response, the platform's relative angular velocity will vary in damping harmonic oscillations with frequency v and a damping coefficient h , tending as $t \rightarrow \infty$ to a steady-state value ω_{otn}^* .

The quantity ν_0 is the natural frequency of the system's undamped oscillations. The damping factor

$$b = \frac{h}{2\nu_0} = \frac{1}{2\nu_0} \left(\frac{1}{T_{20}} + \nu_0^2 T_0 \right) = \frac{1}{2} \sqrt{\frac{K_a}{HK_{21}K_yK_{22}T_{20}}} \left(1 + \frac{H}{K_a} K_{21}K_yK_{22}T_0 \right), \quad (49)$$

the period

$$T = \frac{2\pi}{\nu} = \frac{2\pi}{\nu_0 \sqrt{1-b^2}}, \quad (50)$$

and the damping decrement

$$D = e^{-\frac{T}{2}} = e^{-\frac{\pi b}{\sqrt{1-b^2}}}. \quad (51)$$

Let us consider the nature of the transient response given by Expression (47) as a function of the parameters of the apparatus.

Here, we shall use relative dimensionless quantities:

the relative dimensionless velocity

$$\tilde{w}_{otn} = \frac{w_{otn}}{w_{otn}^*} \quad (52)$$

and the relative dimensionless time

$$\tau = \frac{2\pi t_1}{T_0} = \nu_0 t_1. \quad (53)$$

The velocity \tilde{w}_{otn} is the velocity w_{otn} expressed as a fraction of the velocity w_{otn}^* . The time τ is the time t_1 measured in fractions of the period $T_0 = 2\pi/\nu_0$ of the free undamped oscillations.

Substituting (48), (49), (52) and (53) in (47), we obtain

$$\tilde{w}_{otn} = 1 - \frac{1}{\sin \theta} e^{-\tau} \sin(\sqrt{1-b^2} \tau + \theta), \quad (54)$$

where

$$\sin \theta = \sqrt{1-b^2}. \quad (55)$$

It is evident from this that the nature of the second transient-response stage is fully determined by the magnitude of the damping factor b . Figure 7 shows transient-response curves obtained with damping factors 0.6, 0.7 and 0.8. The broken lines represent the

geometrical positions of successive amplitudes A_1, A_2, A_3 and so forth. The circles on the broken lines denote amplitudes obtained at corresponding damping factors \underline{b} .

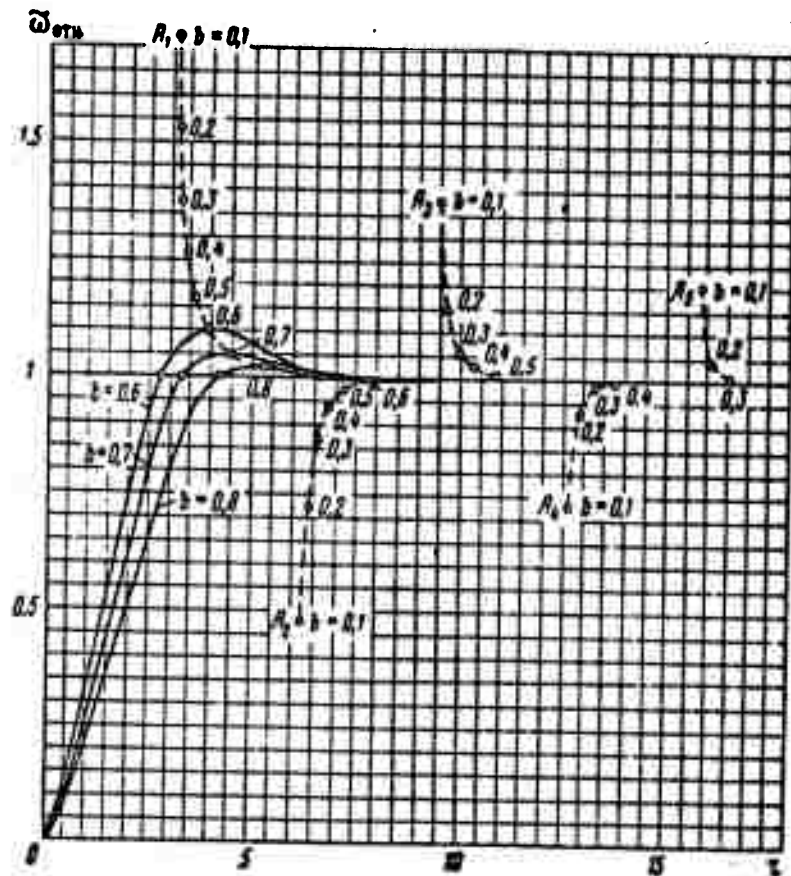

Fig. 7. Diagrams of second stage of transient response for various values of the damping factor \underline{b} .

The period of variation of the velocity $\tilde{\omega}_{otn}$ is

$$T_1 = \frac{2\pi}{\sqrt{1-b^2}} = \frac{2\pi}{\sin \theta} = v_0 T_0 \quad (56)$$

while the damping decrement is determined by Formula (51), as for the velocity ω_{otn} . The time at which the velocity $\tilde{\omega}_{otn}$ first becomes equal to unity

$$\tau_0 = \frac{T_1}{2} - \frac{\theta}{\sin \theta} = \frac{1}{\sin \theta} (\pi - \theta). \quad (57)$$

Thereafter, $\tilde{\omega}_{otn} = 0$ at intervals equal to $T_1/2$.

Curves of T_τ , D , τ_* and θ as functions of the damping factor \underline{b} are shown in Fig. 8. These diagrams are convenient for use in con-

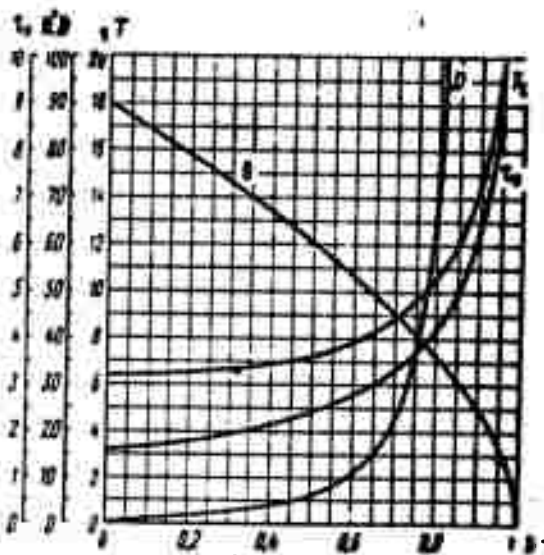

Fig. 8. Curves of T_τ , D , τ_* and θ as functions of damping factor b .

structuring transient-response curves for $b < 1$.

If the parameters of the device are so selected that $b = 0.8$, the damping decrement $D = 66.6$ and, consequently, $\tilde{\omega}_{otn \max} = 1 + A_1 = 1.015$. This value will be reached at $\tau = T_\tau/2 = 5.24$. Thus, if $b = 0.8$, ω_{otn} will not exceed ω_{otn}^* by more than 1.5% during the entire transient response.

Now that we have examined both stages of the transient response, we may construct the diagram of the transient response as a whole. For $b = 0.8$, this diagram will take the form shown in Fig. 9. The time t and the dimensionless time τ are plotted against the axis of abscissas. The segment on the axis of abscissas equal to the pickup time t_{tr} is taken arbitrarily, since it is required

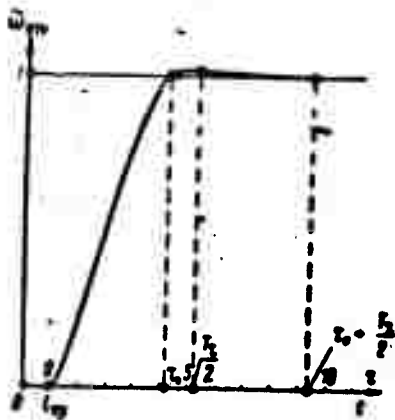

Fig. 9. Transient response for $b = 0.8$.

to know the time appearing in Formula (41) to compute the time t_{tr} .

Let us now consider how the voltages U_{vykh} and U_u will vary during the second stage of the transient process. Substituting (47) in Equation (34) and integrating, we obtain an expression for U_{vykh} . Then, substituting this expression and its first derivative in Equation (35), we obtain an

expression for U_u . The integration constant is found from the first initial condition (43). Thus, we find the following expressions to determine the laws of variation of U_{vykh} and U_u during the second

stage of the transient process:

$$U_{out} = U_{out}^* + \frac{K_u \omega_{otn}^2}{\nu} e^{-M} \sin(\nu t_1 + 2\theta). \quad (58)$$

$$U_y = U_y^* + \frac{K_y K_u \omega_{otn}^2}{\nu} [\sin^2 \theta + (\cos \theta - \nu n T_p)^2] e^{-M} \sin(\nu t_1 + \theta + \theta_1), \quad (59)$$

where

$$\operatorname{tg} \theta_1 = \frac{\sin \theta}{\cos \theta - \nu n T_p}. \quad (60)$$

Expressions (58) and (59) indicate that in the second stage of the transient response, the voltages U_{vykh} and U_u vary in the same way as the velocity ω_{otn} — in damping harmonic oscillations with a frequency ν and a damping coefficient h , tending as $t \rightarrow \infty$ to the steady-state values U_{vykh}^* and U_u^* . The phases of the voltages U_{vykh} and U_u differ from the phase of the velocity ω_{otn} by the respective angles θ and θ_1 .

During the transient response, therefore, the voltages U_{vykh} and U_u first vary linearly up to the time t_{tr} as given by Equations (39) and (40). Beginning with the time t_{tr} , however, they vary in damping harmonic oscillations.

The fact that the platform begins to turn not immediately but only after a lag time t_{tr} has passed is highly undesirable. Consequently, the parameters of the apparatus should be so chosen that $t_{tr} = 0$. In principle, this can be achieved as follows. It is necessary to select the product nT_p in such a way that the right member of Expression (41) will be zero, i.e., so that $t_{tr} = 0$. Setting $t_{tr} = 0$ in (41), we obtain the following value for nT_p at which the lag time vanishes:

$$nT_p = \frac{\pm U_{tr} + K_y U_{out}}{K_y K_u \omega_{otn}^2}. \quad (61)$$

The presence of the voltage U_{Ovykh} , which is a random quantity, in this expression renders the value of nT_p indeterminate. Consequently, measures should be taken so that at $t = 0$, i.e., when the current

I_{zd} is applied, the voltage U_{Ovykh} will practically always have the same small value, insofar as this is possible. This may be achieved, for example, by connecting the gyroscope's pickup and setter in the circuit of a differential gyroscope with feedback, i.e., with an "electric spring" before the current I_{zd} is applied. It will be recalled that in such a gyroscope, the voltage U_{vykh} is supplied through an amplifier (we shall refer to this as the feedback amplifier) to the setter control winding. With this hookup, U_{Ovykh} must be

$$U_{Ovykh} = \frac{H\omega_3 \sin \gamma}{K_{zs} K'_y} = \frac{I_s}{K'_y}, \quad (62)$$

where $K'_u = I_u / U_{vykh} = \text{const}$ is the feedback-amplifier gain, which is equal to the ratio of the amplifier output current I_u to the voltage U_{vykh} impressed upon its input.

After the certain amount of time that is necessary for the gyroscope to reach equilibrium, i.e., for the output voltage of the pickup to become equal to the magnitude determined by Equality (62), the feedback circuit will be disconnected (the setter will be cut off from the output of the feedback amplifier), and simultaneously the required current I_{zd} will be fed to the setter.

Substituting (62) in (61), we obtain

$$nT_p = \frac{\pm U_p + I_s \frac{K_y}{K'_y}}{K_y K_{\omega} \omega_{otn}^*}$$

The gain K'_u should be selected such that the second term in the numerator will be as small as possible. The value of nT_p depends on both the magnitude and the sign of the velocity ω_{otn}^* . Consequently, for the time t_{tr} to be zero for all possible values of the velocity ω_{otn}^* , the value of nT_p should be set equal to its maximum possible value, which will occur at the lowest possible positive velocity ω_{otn}^* :

$$(nT_s)_0 = \frac{U_{TP} + I_0 \frac{K_y}{K_y'}}{K_y K_{\omega} |\omega_{OTN}^*|_{min}} \quad (63)$$

Now let us see what kind of transient response we shall have. We assume that at $t = 0$, when the current $I_{zd} = \text{const}$ is momentarily applied, the values $\omega_{OTN} = 0$ and $U_{Ovykh} = I_*/K'_U$. Substituting these values of ω_{OTN} and U_{vykh} and Equality (63) into Equations (34), (35) and (36), we obtain for $t = 0$

$$\dot{\omega}_{OTN} = \omega_{OTN} = \frac{K_{AS2}}{T_{AS}} \left[U_{TP} \left(\frac{\omega_{OTN}^*}{|\omega_{OTN}^*|_{min}} \mp 1 \right) + I_0 \frac{K_y}{K_y'} \left(\frac{\omega_{OTN}^*}{|\omega_{OTN}^*|_{min}} - 1 \right) \right] \quad (64)$$

It will be recalled that the upper sign should be taken here for $\omega_{OTN}^* > 0$ and the lower sign for $\omega_{OTN}^* < 0$.

In the case under consideration (at $t = 0$)

$$\begin{aligned} |U_{Oy}| &= U_{TP} \text{ for } |\omega_{OTN}^*| = |\omega_{OTN}^*|_{min}, \\ |U_{Oy}| &> U_{TP} \text{ for } |\omega_{OTN}^*| > |\omega_{OTN}^*|_{min}. \end{aligned}$$

As a result, rotation of the platform will begin without any delay, i.e., simultaneously with application of the current I_{zd} to the gyroscope setter. In this case, therefore, the transient response will be described from beginning to end by the differential equation (44). Integrating this equation for the initial conditions adopted, we obtain

$$\omega_{OTN} = \omega_{OTN}^* \left[1 - \frac{1}{\sin \theta_2} e^{-h t} \sin(\nu t + \theta_2) \right] \quad (65)$$

where

$$\text{tg } \theta_2 = \frac{\nu}{h - \frac{\omega_{OTN}^*}{\omega_{OTN}^*}} \quad (66)$$

Expression (65) characterizes a damping oscillatory response with a frequency ν and a damping coefficient h , tending to a steady-state value of ω_{OTN}^* as $t \rightarrow \infty$. The period of the oscillations and the damping decrement are determined, as before, by Formulas (50) and (51). The

phase angle θ_2 is now, as will be seen from (66), a function of the velocity ω_{otn}^* . The time t_* at which the velocity ω_{otn} first reaches the value ω_{otn}^* will be

$$t_* = \frac{\pi - \theta_2}{\nu} \quad (67)$$

In this case, the voltages U_{vykh} and U_u will be determined throughout the transient response by the expressions

$$\left. \begin{aligned} U_{out} &= U_{out}^* + \frac{K_u \omega_{otn}^*}{\nu_0 \sin \theta_2} e^{-h t} \sin(\nu t + \theta_2 + \theta) \\ U_y &= U_y^* + \frac{K_y K_u \omega_{otn}^*}{\nu_0 \sin \theta_2} \{ \sin^2 \theta + [\cos \theta - \nu_0 (nT_p)_0]^2 \} \times \\ &\quad \times e^{-h t} \sin(\nu t + \theta_2 + \theta_{10}) \end{aligned} \right\} \quad (68)$$

where

$$\operatorname{tg} \theta_{10} = \frac{\sin \theta}{\cos \theta - \nu_0 (nT_p)_0} \quad (69)$$

Expressions (68) characterize damping oscillatory processes with a frequency ν and a damping coefficient h , tending to steady values of U_{vykh}^* and U_u^* as $t \rightarrow \infty$.

If the magnitude of nT_p is smaller for some reason than $(nT_p)_*$, then with

$$|\omega_{otn}^*| < \frac{U_{tp} + I_0 \frac{K_x}{K_y}}{K_y K_u n T_p} \quad (70)$$

the transient response will consist of the two stages examined above; rotation of the platform will begin with a time lag t_{tr} . There will be no lag for speeds ω_{otn}^* the absolute magnitude of which is equal to or greater than the right side of Inequality (70).

All of the above conclusions were made on the assumption that the systematic component of the disturbance moment is compensated by a current I_k and that its accidental component and the frictional moment in the supports of the floated gyroassembly are zero. However, it is virtually impossible to achieve all of these things in full measure,

so that both the moment M_p and the moment M_t will exert a certain influence on the performance of the rotary device. Let us consider the basic aspects of this influence.

Influence of moments M_p and M_t on performance of apparatus.

Assume that $M_t = \text{const}$. The moment M_p will be regarded as constant in both magnitude and sign to simplify the reasoning to follow. In addition, we shall assume that the gyroscopic moment produced by the vertical component of the Earth's diurnal rotation is considerably larger than the sum of the moments M_t and M_p :

$$H\omega_3 \sin \varphi \gg |M_t + M_p| \quad (71)$$

as must be the case with floated gyroscopes.

The right member of Equation (7) is the sum of the torques acting on the floated gyroassembly, taken with its sign reversed. Let us denote this sum by M ; then we have

$$M = -H\omega_{\text{otn}} - H\omega_3 \sin \varphi + K_{22}J_{22} + M_a \pm M_r \quad (72)$$

The first term in the right member of (72) is the gyroscopic moment that arises due to the presence of the platform's relative angular velocity ω_{otn} . If $\omega_{\text{otn}} = 0$, then

$$M = M_0 = -H\omega_3 \sin \varphi + K_{22}J_{22} + M_a \pm M_r \quad (73)$$

The first three terms of the right member of (73) are active torques. Let us denote their sum by M_a . Motion of the floated gyroassembly about its axis can begin only provided that $|M_a|$ is larger than M_r . This condition may be written in the form of the inequality

$$|-H\omega_3 \sin \varphi + K_{22}J_{22} + M_a| > M_r$$

Thus, for the floated unit to begin to rotate with a velocity $\dot{\beta} < 0$, and, consequently, for the platform to begin rotation with a velocity $\omega_{\text{otn}} > 0$, the following inequality must be satisfied:

$$-H\omega_3 \sin \varphi + K_{22}J_{22} + M_a > M_r$$

From this, we find that in our case we must have $I_{2d} > I_2$:

$$I_3 = \frac{1}{K_{\text{m}}} (H\omega_3 \sin \varphi - M_p + M_r) = I_* + \frac{M_r - M_p}{K_{\text{m}}}. \quad (74)$$

Accordingly, for the floated gyroassembly to begin turning at a speed $\dot{\beta} > 0$ and for the platform to begin to rotate at a speed $\omega_{\text{otn}} < 0$, the following equality must be satisfied:

$$-(-H\omega_3 \sin \varphi + K_{\text{m}} I_{\text{zd}} + M_p) > M_r.$$

It follows from this inequality that the current I_{zd} must be smaller than the current

$$I_1 = \frac{1}{K_{\text{m}}} (H\omega_3 \sin \varphi - M_p - M_r) = I_* - \frac{M_r + M_p}{K_{\text{m}}}. \quad (75)$$

At currents I_{zd} that satisfy the inequality

$$I_1 < I_{\text{zd}} < I_3, \quad (76)$$

the floated gyroassembly will remain stationary ($\dot{\beta} = 0$).

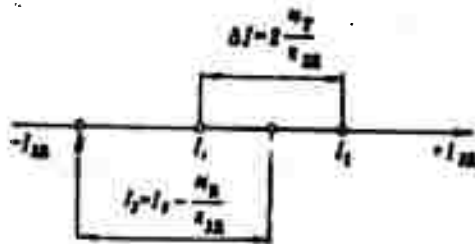

Fig. 10. Magnitude and location of dead zone.

If now

$$|\dot{\beta}| < \frac{U_{\text{op}}}{K_{\text{m}} K_{\text{y}}},$$

the platform will also be stationary ($\omega_{\text{otn}} = 0$). The quantity

$$\Delta I = I_3 - I_1 = \frac{2M_r}{K_{\text{m}}} \quad (77)$$

will be a dead zone. This zone is situated symmetrically relative to the current

$$I_2 = \frac{I_1 + I_3}{2} = I_* - \frac{M_p}{K_{\text{m}}}. \quad (78)$$

It is evident from this that if $M_p > 0$, then $I_3 < I_*$, while when $M_p < 0$, $I_3 > I_*$.

Thus, the torque M_t dictates the presence of a dead zone whose size is determined by Equality (77). The location of this zone depends on the magnitude and sign of the torque M_p . A clear graphic interpretation can be provided for the above. For this purpose, values of the current I_{zd} will be laid off (on some scale) along the axis OI_{zd} with

its origin at point 0, which corresponds to the zero value of I_{zd} (Fig. 10). Laying off the values I_1 , I_2 , I_3 determined by Expressions (75), (74) and (78) on the OI_{zd} axis, we obtain a clear presentation of the location and size of the dead zone, which is marked by the heavy line.

The larger K_{zd} , the smaller will be the dead zone and the shorter the displacement of its center relative to the current I_* , all other conditions the same.

Expressions (77) and (78) enable us to determine the quantities M_t and M_p from known currents I_1 and I_2 . The values of the currents I_1 and I_2 , on the other hand, can, in principle, be determined by smooth delivery of the current I_{zd} to the setter with simultaneous measurement of the voltage U_{vykh} . If I_1 and I_2 are known, then

$$M_t = \frac{K_{zs}}{2} (I_2 - I_1), \quad (79)$$

$$M_p = K_{zs} \left(\frac{I_1 + I_2}{2} - I_0 \right). \quad (80)$$

Excluding U_{vykh} and U_u from Equations (7), (35) and (36), we obtain the following differential equation, which describes the time variation of the relative angular velocity of the platform, ω_{otn} , on instantaneous application of a current $I_{zd} = \text{const}$ to the gyroscope setter when the current does not satisfy inequality (76):

$$\ddot{\omega}_{otn} + 2h\dot{\omega}_{otn} + v_0^2\omega_{otn} = v_0^2 \left(\omega_{otn}^0 + \frac{M_t}{H} \pm \frac{M_p}{H} \right). \quad (81)$$

It will be recalled that the upper sign must be taken before M_t for $\dot{\beta} > 0$ and the lower sign for $\dot{\beta} < 0$.

Equation (81) is analogous to the equation of damping oscillations of a point in the simultaneous presence of a resistance proportional to the first power of velocity and Coulomb friction. Such an equation was investigated in detail by B.V. Bulgakov*. Coulomb friction does not influence the period of oscillation. Consequently, the

oscillation period in this case will be determined by Formula (50), as with $M_t = 0$. The velocity ω_{otn} will reach its steady-state value by way of damping oscillations executed about two alternating equilibrium positions determined by the sign of the velocity $\dot{\beta}$. It will be seen from Equation (81) that with $\dot{\beta} < 0$, the oscillations will be performed about a value ω_{otn} equal to

$$\omega_{1otn} = \omega_{otn}^{\infty} - \frac{M_t}{H}, \quad (82)$$

and with $\dot{\beta} > 0$ about

$$\omega_{2otn} = \omega_{otn}^{\infty} + \frac{M_t}{H}, \quad (83)$$

where

$$\omega_{otn}^{\infty} = \omega_{otn}^{\circ} + \frac{M_p}{H} \quad (84)$$

is the steady-state velocity at $M_t = 0$.

The steady-state value of the velocity ω_{otn} , which we shall denote by ω_{otn}^{***} , will occur between ω_{1otn} and ω_{2otn} or will be equal to one of these velocities:

$$\omega_{1otn} \leq \omega_{otn}^{***} \leq \omega_{2otn}. \quad (85)$$

The dependence of the velocities ω_{1otn} , ω_{2otn} and ω_{otn}^{**} on the current I_{zd} are shown in Fig. 11. The point corresponding to the velocity value ω_{otn}^{***} obtained at a certain arbitrary current I_{zd} will occur in the hatched region somewhere on the segment AC (Fig. 11). If the velocity ω_{otn}^{***} is reached at $\dot{\beta} > 0$, then the value ω_{otn}^{***} will be determined by some point on the segment BC; if, on the other hand, ω_{otn}^{***} is reached at a $\dot{\beta} < 0$, its value will be determined by one of the points of segment AB. However, it is apparently impossible to predict in advance on precisely what part of the segment AC the point defining the value of the velocity ω_{otn}^{***} will occur under real conditions.

Thus, the presence of the moments M_p and M_t results in the

$$E_{\text{sp}} = \frac{(\Delta\omega_{\text{otn}}^*)_{\text{sp}}}{\omega_{\text{otn}}^*} 100 = \frac{M_n \pm M_t}{H\omega_{\text{otn}}^*} 100. \quad (87)$$

The maximum absolute value of this error

$$E_{\text{max}} = \frac{|M_n| + M_t}{H|\omega_{\text{otn}}^*|} 100. \quad (88)$$

If it is required that the error E_{max} for $\omega_{\text{otn}}^* = \omega_{\text{otn}}^* \text{ min}$ not exceed a certain specified magnitude, the condition

$$|M_n| + M_t < \frac{H|\omega_{\text{otn}}^*|_{\text{min}} E_{\text{max}}}{100}. \quad (89)$$

must be observed.

Thus, for example, with $H = 100$ g-cm-sec, $|\omega_{\text{otn}}^*|_{\text{min}} = 0.00001$ rad/sec $\approx 2^\circ$ /hour, and $E_{\text{max}} = 1\%$, it is necessary that $|M_p| + M_t \leq 0.00001$ g-cm = 0.1 mg-mm. If, on the other hand, a gyroscope with $H = 10,000$ g-cm-sec is taken, then $|M_p| + M_t \leq 0.001$ g-cm = 10 mg-mm is permissible.

If at $t = 0$ with $|U_{\text{Ovykh}}| < U_{\text{tr}}$, a current $I_{\text{zd}} = I_*$ is fed to the gyroscope's setter, then with $|M_p| > M_t$, the platform will go into rotation with a certain speed the maximum value of which will be $(\Delta\omega_{\text{otn}}^*)_{\text{pr}}$ [see Equation (86)]. Consequently, $(\Delta\omega_{\text{otn}}^*)_{\text{pr}}$ may be referred to as the maximum possible drift rate. As we have already noted, this velocity will be the smaller the larger H . If, on the other hand, $|M_p| < M_t$, the platform will not be able to start rotating at all. Consequently, with $|M_p| < M_t$, there will be no drift. However, this does not mean that it is necessary to increase the moment M_t to eliminate drift, since when $I_{\text{zd}} \neq I_*$, an increase in M_t will result in an increase in the maximum values of the absolute and relative errors $(\Delta\omega_{\text{otn}}^*)_{\text{pr}}$ and E_{max} . Consequently, all measures should be taken with the gyroscope used in the apparatus to minimize both the torque M_p and the torque M_t .

It was noted above that if the moment $M_p = \text{const}$, it may be com-

compensated by supplying an appropriate current I_k to the setter. We see from (86) and (88) that if the torque M_p is compensated, the error will be due solely to the moment M_t , and there will be no drift at all. In reality, however, $M_p \neq \text{const}$ and only its systematic component can be compensated. Hence both the error and the drift will be governed under real conditions by the accidental component of the moment M_p and by the moment M_t , which, as a result, should be minimized.

The actual values of the errors generated by the torques M_p and M_t can be determined only experimentally; for this purpose, various currents I_{zd} should be applied to the setter and the velocities ω_{otn}^{***} obtained in this process determined. The error values should be computed by the formulas

$$\Delta \omega_{otn}^{\circ} = \omega_{otn}^{***} - \omega_{otn}^{\circ} \quad (90)$$

$$E = 100 \frac{\Delta \omega_{otn}^{\circ}}{\omega_{otn}^{\circ}} = \left(\frac{\omega_{otn}^{***}}{\omega_{otn}^{\circ}} - 1 \right) 100\% \quad (91)$$

The values of ω_{otn}° are figured by Formula (23).

The above considerations concerning the influence exerted by the torques M_p and M_t on the performance of the device must be taken into account in selecting the gyroscope for it. In selecting the parameters of the device, on the other hand, the moments M_p and M_t may be disregarded in view of their small magnitude.

Use of reducing gear. In describing the operating principle and investigating the performance of the rotary-platform apparatus, we assumed that the drive motor was mounted directly on the rotary-platform shaft (see Fig. 1). All considerations developed from this and all relationships derived remain valid also for the case in which rotation of the platform is effected off the motor through a reducing gear that has no backlash. When a reducing gear is used, it is

necessary to multiply the motor torque M_{dv} in Equation (17) by the reducer's ratio \underline{i} . In all subsequent formulas containing the coefficient K_{dvl} , it should accordingly be replaced by the product iK_{dvl} . Moreover, when the reducer is present, the moment J will be a reduced moment of inertia. With increasing \underline{i} , the required value of K_{dvl} will be reduced by a factor of \underline{i} , so that it will be possible to use a motor with a less "rigid" mechanical characteristic.

Selection of basic parameters for rotary platform. The gyroscope parameters H , K_d , K_{zd} , and K_{dt} , the moment of inertia J , the static moment M_s of the rotating platform, the maximum steady-state value of the amplifier output voltage $U_{u \max}^*$, the velocities $\omega_{otn \min}^*$, $\omega_{otn \max}^*$ and the corresponding angles β_{\min}^* and β_{\max}^* and the angle β_0 and the damping factor \underline{b} will be regarded as given.

It should be remembered in selection of the device's parameters that the damping factor \underline{b} and the product $(nT_p)^*$ do not depend on the coefficient K_{dv2} . We may usually satisfy ourselves of this by substituting the value of K_u given by Equality (29) in Expressions (49) and (63).

Thereafter, all expressions will show only the absolute magnitudes of velocities and angles, so that we shall not write the absolute bars in order to simplify our notation.

The minimum required motor power (in watts) may be determined by the formula

$$P_{\min} = 9.81 \omega_{otn \max}^* M_s \quad (92)$$

Substituting $\beta^* = \beta_{\min}^*$, $\omega_{otn}^* = \omega_{otn \min}^*$ in Expression (28) and solving it for K_u , we obtain

$$K_u = \frac{1}{K_{dv2} K_{dt}^2} \left(\omega_{otn \min}^* + \frac{M_s}{K_{dt}} \right).$$

Equating this expression for K_u to Expression (29) and solving the

resulting equation for K_{dv1} , we obtain

$$K_{dv1} = \frac{M_c}{\omega_{otn\ min}^*} \frac{p-1}{q-p} \quad (93)$$

where

$$p = \frac{\beta_{max}^*}{\beta_{min}^*}, \quad q = \frac{\omega_{otn\ max}^*}{\omega_{otn\ min}^*} \quad (94)$$

Using Formula (93), we determine the required value of the motor's mechanical-characteristic rigidity K_{dv1} .

Setting $\omega_{otn}^* = \omega_{otn\ max}^*$ and $U_u^* = U_u^*_{max}$ in Equation (27), we obtain from it

$$K_{dv2} = \frac{\omega_{otn\ max}^*}{U_{y\ max}^* - U_{tr}} \quad (95)$$

The motor should be selected on the basis of the magnitude of $U_u^*_{max}$ and the values found for P_{dv} , K_{dv1} and K_{dv2} .

The values of the damping factor U_{tr} , the amplifier gain K_u , the time constant T_{dv} and the natural nondamping-oscillation frequency ν_0 are computed from Formulas (26), (29), (19) and (45), respectively.

Substituting (2) in (62), we determine the feedback-amplifier gain:

$$K_y = \frac{I_0}{\beta_0 K_{dv}} \quad (96)$$

From (49) we determine

$$nT_p = \frac{1}{\nu_0} \left(2b - \frac{1}{\nu_0 J_m} \right) \quad (97)$$

The value of nT_p computed by this formula must be larger than or equal to the value of $(nT_p)_*$ determined by Formula (63). Thus the basic parameters of the rotary-platform device may be determined. If the values of the individual parameters are found inapplicable for one reason or another, it is then necessary to change the initial values and make the calculations over again.

Let us now consider how the calculation will be carried out when

a reducing gear is used. The motor power (in watts) is

$$P_{20} = 9,81 \frac{\omega_{\text{отн max}}^2 M_c}{\eta}, \quad (98)$$

where η is the efficiency of the reducing gear.

Then the motor should be selected and its mechanical and speed characteristics used as a basis for determining the coefficients K_{dv1} and K_{dv2} .

Substituting iK_{dv1} for K_{dv1} in (93), we determine the ratio of the reducing gear:

$$i = \frac{M_c}{K_{201} \omega_{\text{отн min}}^2} \frac{p-1}{q-p}. \quad (99)$$

We obtain from (95)

$$U_{y \text{ max}}^* = U_{\text{тп}} + \frac{\omega_{\text{отн max}}^2}{K_{202}}. \quad (100)$$

If the value of $U_{u \text{ max}}^*$ is found unusable, it is necessary to select a motor with a different speed characteristic, i.e., with a different value of K_{dv2} .

The remaining quantities are determined in the same way as when there is no reducing gear, the only difference being that iK_{dv1} is substituted into the formulas instead of K_{dv1} .

If the reducer's ratio i and the voltage $U_{u \text{ max}}^*$ are regarded as fixed, the coefficient K_{dv1} is figured from the formula

$$K_{201} = \frac{M_c}{i \omega_{\text{отн min}}^2} \frac{p-1}{q-p}, \quad (101)$$

and the coefficient K_{dv2} from Formula (95). The motor is selected on the basis of the values of P_{dv} , K_{dv1} and K_{dv2} . The further calculation remains the same as for the case in which i is not given.

Use of rotary-platform apparatus. The rotary device may be used to test both integrating and differentiating floated gyroscopes. Integrating gyroscopes are subjected to the following basic tests:

- a) a drift test;

- b) a test of performance in the spatial-integration mode;
- c) a test for performance in the geometrical-stabilization mode;
- d) determination of the time constant.

To test a gyroscope for performance in the geometrical-stabilization mode, the apparatus (see Fig. 1) must be supplemented by still another rotary device, which is secured to the platform 1. The gyroscope to be tested is mounted on the rotating platform of the supplementary apparatus.

Let us devote brief consideration to the basic problems involved in testing integrating gyroscopes for drift. The angular rate of drift of a floated integrating gyroscope (we shall denote it by ω_{dr}) is the absolute angular velocity with which it is necessary to turn the instrument about its input (measurement) axis for the output signal of the gyroscope - the voltage U_{vykh} - to be constant (close to zero) with a current $I_{zd} = 0$. In other words, this is the speed with which the instrument must be turned about its input axis to set up a gyroscopic moment equal in magnitude and opposed in sign to the disturbance torque acting on the floated gyroassembly about its axis of rotation. Consequently, on rotation of the device with a speed ω_{dr} with $I_{zd} = 0$, the floated gyroassembly will be at equilibrium, so that $U_{vykh} = \text{const.}$ If the instrument were ideal, i.e., if $M_p = M_t = 0$ were the case, then ω_{dr} would be equal to zero.

The drift of a gyroscope is determined to a considerable degree by the imbalance of the floated gyroassembly about its axis of rotation; this occurs as a result of noncoincidence of the unit's center of gravity with its center of pressure. The component of the angular drift rate governed by this cause is known as the gravitational drift component and may be denoted by $\omega_{dr.gr}$. The angular velocity $\omega_{dr.gr}$ depends on the orientation of the floated gyrounit relative to the

gravity vector. Also dependent upon this orientation is the magnitude of the residual frictional moment in the supports of the floated gyro-assembly, which influences the value of ω_{dr} to a certain degree.

On the basis of the above, the drift rate must, as a rule, be determined for the horizontal and vertical positions of the instrument's output axis (the axis of rotation of the floated gyroassembly). When the instrument's output axis is horizontal, the observed drift rate (let us denote it by $\omega_{dr.gor}$) is due to all factors giving rise to drift, including the imbalance of the floated gyroassembly relative to its axis of rotation. In the vertical position of the instrument's output axis, the drift rate, which we shall designate $\omega_{dr.vert.}$, will not contain the gravitational drift component, since with the axis of rotation of the floating gyroassembly in its vertical position, the moments of the force of gravity and the lifting force about it are zero. Thus, for example, the drift observed in this case is governed by all factors excepting the imbalance of the floated gyroassembly about its axis of rotation. In the latter case, the frictional moment in the supports of the floated gyroassembly has virtually no effect.

Thus, the gravitational drift component may be set equal to

$$\omega_{dr.gor} = \omega_{dr.vert.} + \omega_{dr.grav.} \quad (102)$$

In drift testing, the device 5 to be tested should be secured on the platform 1 in the manner shown in Fig. 1. The instrument's output axis (x-axis) and its z_0 -axis must be perpendicular to the platform's axis of rotation; the device's input axis (y-axis) must be situated colinearly with or parallel to the platform axis of rotation. The angular velocity $\omega_{dr.gor}$ should be determined for different angles δ of inclination of the z_0 -axis to the plane of the horizon, namely, $\delta = 0, 90^\circ$, and at several values $0^\circ < \delta < 90^\circ$. In these tests, the platform axis of rotation and the z_0 -axis should be in the plane of the meridian,

with the platform axis of rotation inclined to the vertical through an angle $\gamma = \vartheta$. The value obtained for the angular velocity $\omega_{dr.gor}$ for a certain specific angle $\vartheta = \vartheta^*$ will be denoted by $(\omega_{dr.gor})_{\vartheta = \vartheta^*}$.



Fig. 12. Rotary-platform apparatus. 1) Base of apparatus; 2) pedestal column; 3) fork arms; 4) housing with motor; 5) rotary platform; 6) bearings; 7) sector; 8) holes in sector; 9) locating pin; 10) floated integrating gyroscope being tested; 11) control and monitoring panel.

In determining $\omega_{dr.vert}$, the platform axis of rotation must be situated horizontally ($\gamma = 90^\circ$) in the plane of the meridian.

Thus, in drift testing of integrating gyroscopes, it is necessary to set the platform axis of rotation (see Fig. 1) at various angles to the vertical. One possible design variant of the rotary platform (used by the firm Sperry), which makes it possible to set the platform axis of rotation at various angles to the vertical, is shown in Fig. 12.*

(This apparatus corresponds to the diagram of Fig. 1).

The base 1 of the rotary apparatus rests on a column 2, which is completely insulated from the building and, consequently, completely unperturbed by its vibrations. The two fork arms 3 are rigidly secured to the base 1. The housing 4 with the motor is fitted with two journals which ride in the bearings 6, which, in turn, are carried in the arms 3. The journal axis is perpendicular to the rotation axis of the platform 5. The journal axis, which is the inclination axis of the rotary platform, is set in a strictly horizontal position by adjusting the heights of the feet on the base 1. The left-hand journal carries the sector 7 with its holes 8, which is rigidly secured to the housing 4. The locating pin 9 is found in the left arm 3. By inclining

the rotary-platform unit about the journal axis and pushing the locating pin 9 into any of the holes 8, the rotation axis of the rotary platform may be set vertical, horizontal, or, on the other hand, at any angle to the vertical that is a multiple of the angular interval between the holes 8. The instrument 10 to be tested is secured to the rotary platform 5 in such a way that the rotation axis of the floated gyroassembly will be perpendicular to the platform axis of rotation. As we have already noted, the instrument's input axis must be situated colinear with or parallel to the platform axis of rotation.

Before each drift test, the floated gyroassembly should be set up in its initial position ($\beta \approx 0$). This can be done by connecting the pickup and setter in the circuit of a feedback differentiating gyroscope. After the floated gyroassembly has been brought to its initial position, the feedback circuit is disconnected and the input of the amplifier 9 (see Fig. 1) is connected to the output winding 6 of the pickup. The control winding of the setter is left currentless, i.e., $I_{zd} = 0$.

In all cases where integrating gyroscopes are to be drift-tested, the angular drift rate is equal to the absolute angular velocity of the platform about its axis of rotation and, consequently, must be determined by the formula

$$\omega_{zp} = \omega_{otn} + \omega_{per} \quad (103)$$

where ω_{otn} is the relative angular velocity of the platform about its axis of rotation, as determined by measuring the angle and time of rotation of the platform in the drift test of the gyroscope, i.e., at $I_{zd} = 0$;

$$\omega_{per} = \omega_p \sin(\varphi + \gamma) \quad (104)$$

$[\omega_{per}]$ is the transmitted velocity of the platform about its axis of rotation, which is due to the angular velocity of the Earth's diurnal

rotation; γ is the angle between the platform axis of rotation (y-axis) and the vertical.

Let us consider a somewhat similar drift test with the axes x and z_0 in the horizontal position (see Fig. 1). In this case, the positioning of the platform and instrument relative to the planes of the horizon and the meridian should correspond to the diagram of Fig. 13a ($\delta = \gamma = 0$).

If in this test the axis z_0 is not in the plane of the meridian, but forms a certain angle ψ with it, the supports of the floated gyro-assembly will experience an additional load governed by the gyroscopic moment

$$G_y = H\omega_z \cos \varphi \sin \psi,$$

acting about the y-axis and arising due to the presence of the horizontal component of the Earth's diurnal rotation. However, this moment is not large in gyroscopes with small H. Thus, for example, with $H = 100$ g-cm-sec, $\varphi = 60^\circ$, and $\psi = 90^\circ$, the moment $G_u \approx 3.6$ mg-cm. In Fig. 13a, the angle $\psi = 0$.

It follows from Expressions (31), (82), (83), (84) and (85) that in the case under consideration, the relative angular velocity of the platform $\omega_{otn} = \omega_{otn}^{***}$, with

$$-\omega_z \sin \varphi + \frac{M_2}{H} - \frac{M_1}{H} < \omega_{otn}^{***} < -\omega_z \sin \varphi + \frac{M_2}{H} + \frac{M_1}{H}.$$

The limiting values of this velocity are

$$\omega_{otn, \text{op}}^{***} = -\omega_z \sin \varphi + \frac{M_2}{H} \pm \frac{M_1}{H}. \quad (105)$$

Substituting Equalities (105) and (104) into Formula (103), we obtain the limiting values for the angular drift velocity

$$(\omega_{dr, \text{op}})_{\text{lim}} = \frac{M_2}{H} \pm \frac{M_1}{H}.$$

It follows from this that the limiting possible values of an inte-

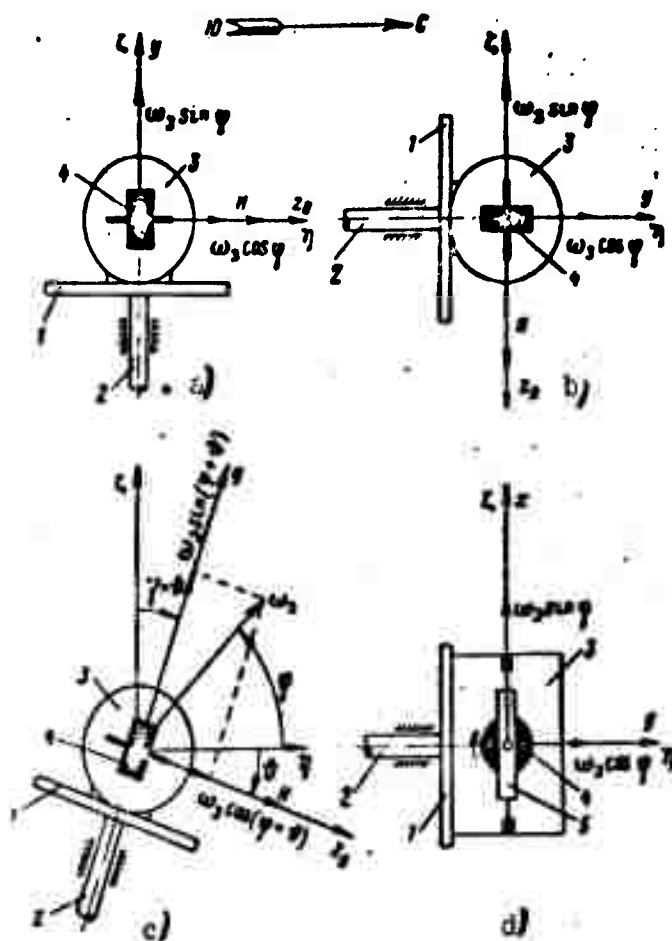

Fig. 13. Positions of rotary platform in various versions of the drift test for a floated integrating gyroscope. 1) rotary platform; 2) rotary-platform axis of rotation; 3) instrument being tested; 4) gyroscope rotor; 5) gyroscope frame; η) horizontal axis, directed north; ζ) vertical axis. a) Axes x and z_0 horizontal; b) x-axis horizontal, z_0 -axis vertical; c) x-axis horizontal, but z_0 -axis inclined to the plane of the horizon at a certain angle δ ; d) x-axis vertical.

grating gyroscope's angular drift rate will be the smaller the larger the intrinsic moment H of the gyroscope (all other conditions the same). This is accounted for as follows. Since the angular drift rate is the velocity with which the instrument must be turned about its input axis to set up a gyroscopic moment equal in magnitude and opposed in sign to the moment $M_p \pm M_t$, then the larger H becomes, the

smaller will be the angular velocity ω_{dr} necessary to set up the required gyroscopic moment. This conclusion is obviously not simply applicable to the case under consideration; it is general.

If the natural moment of the gyroscope H and the coefficient K_{zd} of the instrument being tested are known with sufficient accuracy, it is expedient to deliver a current $I_{zd} = I_*$ to the gyroscope setter in a drift test according to the diagram of Fig. 13a. Then the drift rate $(\omega_{dr.gor})_{\delta=0}$ will be directly equal to the relative angular velocity of the platform.

Figure 13b shows a diagram of the placement of the platform and instrument in a drift test with the x-axis horizontal and the z_0 -axis in the vertical position ($\delta = \gamma = 90^\circ$). In this case, the angular drift rate is

$$(\omega_{dr.gor})_{\delta=90^\circ} = \omega_{otn} + \omega_z \cos \varphi.$$

If a current $I_{zd} = \frac{H}{K_{zd}} \omega_z \cos \varphi$ is fed to the setter, then

$$(\omega_{dr.gor})_{\delta=90^\circ} = \omega_{otn}.$$

To determine the drift velocity for the case in which the x-axis is horizontal while the z_0 -axis is inclined to the horizontal at a certain angle δ , the platform and instrument must be set up in accordance with Fig. 13c. In this case, the drift rate is

$$(\omega_{dr.gor})_{\delta=90^\circ} = \omega_{otn} + \omega_z \sin(\varphi + \delta^\circ).$$

If a current

$$I_{zd} = \frac{H}{K_{zd}} \omega_z \sin(\varphi + \delta^\circ).$$

is applied to the setter, the angular drift rate will be equal directly to the relative angular velocity of the platform, ω_{otn} .

Figure 13d shows a diagram of the platform and instrument positions in a drift test with the x-axis in its vertical position ($\gamma = 90^\circ$). In this case, the angular velocity of drift is

$$\omega_{zp, \text{ drift}} = \omega_{z0} + \omega_z \cos \gamma.$$

If a current $I_{zd} = \frac{H}{K_{zd}} \omega_z \cos \varphi$ is fed to the setter, then

$$\omega_{zp, \text{ drift}} = \omega_{z0}.$$

The angular velocities of drift may be used to determine the detrimental moments acting about the axis of rotation of the floated gyroassembly (the x-axis). Thus, if the x-axis is horizontal and the z_0 -axis forms a certain angle $\vartheta = \vartheta^*$ with the plane of the horizon, then the gravitational moment acting about the x-axis is

$$(M_{n, \text{ rp}})_{\vartheta = \vartheta^*} = H [(\omega_{zp, \text{ top}})_{\vartheta = \vartheta^*} - \omega_{zp, \text{ drift}}].$$

The disturbance moment acting about the x-axis in the vertical position of this axis is

$$M_{n, \text{ drift}} = H \omega_{zp, \text{ drift}}.$$

It was noted above that the rotary apparatus considered here can also be used for testing floated differentiating gyroscopes, which, as we know, are used for precision angular-velocity measurements. The most highly perfected variety of this instrument is the floating feedback differentiating gyroscope or, in other words, the electric-spring gyroscope. Its output signal (quantity) is the output current I_u of a feedback amplifier, which, in an ideally performing instrument, must be proportional to the measured absolute angular velocity ω . Thus, in the steady-state mode with $\omega = \text{const}$, the output signal must be equal to

$$I_u = K_{\text{diff}} \omega.$$

In the ideal instrument $K_{\text{diff}} = \text{const}$. In actuality, this coefficient will be practically constant only in a certain range of velocities ω , which becomes the range used as the instrument's working interval.

At $\omega = 0$, the current I_u must also be equal to zero. However, due

to the presence of the moments M_p and M_t , $I_u \neq 0$ when $\omega = 0$. The angular velocity at which the output signal actually obtained at $\omega = 0$ would arise in an ideal instrument (with the moment $M_p = M_t = 0$) is known as the angular drift rate of the differentiating gyroscope. The drift rate, which we shall denote by ω_{dr} , may be determined by the formula

$$\omega_{dr} = \frac{I_{u,dr}}{K_{\omega}}$$

where $I_{u,dr}$ is the output current obtained at $\omega = 0$.

The rotary installation is employed to determine:

- a) the angular drift rate ω_{dr} ;
- b) the steady-state values of the current I_u as functions of the angular velocity ω ;
- c) the damping factor and frequency of the instrument's natural undamped vibrations.

Manu-
script
Page
No..

[Footnotes]

- 1 C.S. Draper, W. Wrigley and L.R. Grohe. The Floating Integrating Gyro and its Application to Geometrical Stabilization Problems on Moving Bases, Aeronautical Engineering Review, 1956; Aviation Week, 12 March 1956. Advertisement of the Greenleaf firm.
- 29 B.V. Bulgakov, Kolebaniya [Oscillations], GTTI [State Technical and Theoretical Editions], 1954.
- 39 Aviation Week, 10 June 1957, page 84.

Manu-
script
Page
No.

[List of Transliterated Symbols]

3	ВЫХ = vykh = vykhod = output
3	ЗД = zd = zadatchik = setter
5	ДТ = dt = datchik = pickup
5	Г = G = Giroskopicheskiy moment = gyroscopic moment
6	З = Z = Zemlya = Earth
7	ОТН = otn = otnositel'nyy = relative
8	Д = d = dempfiruyushchiy = damping
8	Г = g = girouzel = gyroassembly
8	П = p = pomekha = disturbance
8	Т = t = treniye = friction
9	СИСТ = sist = sistematicheskiy = systematic
9	СЛ = sl = sluchaynyy = accidental
9	К = k = kompensatsionnyy = compensation
10	П = p = preobrazovatel' = converter
11	ДВ = dv = dvigatel' = motor
11	У = u = usilitel' = amplifier
13	С = s = staticheskiy = static
16	ТР = tr = troganiye = pickup
31	ПР = pr = predel'nyy = limiting
38	ДР = dr = dreyf = drift
38	ГР = gr = gravitatsionnyy = gravitational
38	ГОР = gor = gorizonta'l'nyy = horizontal
38	ВЕРТ = vert = vertikal'nyy = vertical
40	ПЕР = per = perenosnyy = transmitted
44	ДИФ = dif = differentsiruyushchiy = differentiating

DISTRIBUTION LIST

DEPARTMENT OF DEFENSE	Nr. Copies	MAJOR AIR COMMANDS	Nr. Copies
		AFSC	
		SCFDD	1
		ASTIA	25
		TDBTL	5
		TDBDP	5
HEADQUARTERS USAF		AEDC (AEY)	1
AFCIN-3D2	1	SSD (SSP)	2
ARL (ARB)	1	APGC (PGP)	1
		ESD (ESY)	1
OTHER AGENCIES		RADC (RAY)	1
CIA	1	AFMDC (MDF)	1
NSA	6	AFSWC (SWP)	1
DIA	9	AFMTC (MTW)	1
AID	2		
OTS	2		
AEC	2		
PWS	1		
NASA	1		
ARMY	3		
NAVY	3		
RAND	1		
NAFEC	1		
SPECTRUM	1		

UNCLASSIFIED

UNCLASSIFIED