

UNCLASSIFIED

AD NUMBER

AD323734

CLASSIFICATION CHANGES

TO: UNCLASSIFIED

FROM: CONFIDENTIAL

LIMITATION CHANGES

TO:
Approved for public release; distribution is unlimited.

FROM:
Distribution authorized to U.S. Gov't. agencies and their contractors;
Administrative/Operational Use; 28 APR 1961.
Other requests shall be referred to Naval Ordnance Test Station, China Lake, CA.

AUTHORITY

30 Apr 1973, DoDD 5200.10, per document marking; USNOTS ltr dtd 30 Apr 1976

THIS PAGE IS UNCLASSIFIED

THIS REPORT HAS BEEN DELIMITED
AND CLEARED FOR PUBLIC RELEASE
UNDER DOD DIRECTIVE 5200.20 AND
NO RESTRICTIONS ARE IMPOSED UPON
ITS USE AND DISCLOSURE.

DISTRIBUTION STATEMENT A

APPROVED FOR PUBLIC RELEASE;
DISTRIBUTION UNLIMITED.

AD 323 734

*Reproduced
by the*

**ARMED SERVICES TECHNICAL INFORMATION AGENCY
ARLINGTON HALL STATION
ARLINGTON 12, VIRGINIA**



NOTICE: When government or other drawings, specifications or other data are used for any purpose other than in connection with a definitely related government procurement operation, the U. S. Government thereby incurs no responsibility, nor any obligation whatsoever; and the fact that the Government may have formulated, furnished, or in any way supplied the said drawings, specifications, or other data is not to be regarded by implication or otherwise as in any manner licensing the holder or any other person or corporation, or conveying any rights or permission to manufacture, use or sell any patented invention that may in any way be related thereto.

DISCLAIMER NOTICE

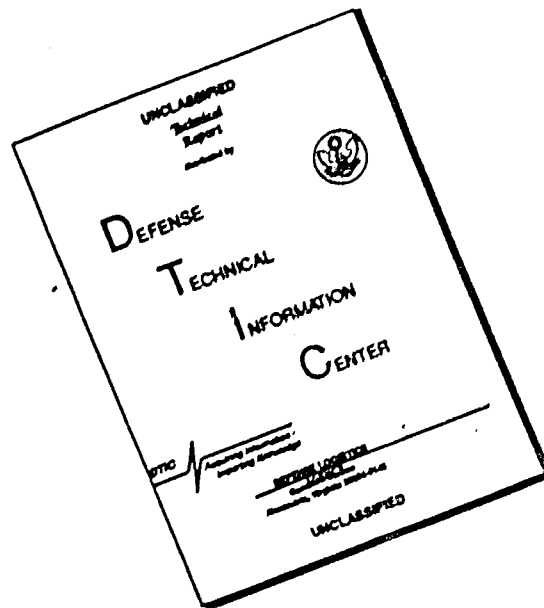

THIS DOCUMENT IS BEST QUALITY AVAILABLE. THE COPY FURNISHED TO DTIC CONTAINED A SIGNIFICANT NUMBER OF PAGES WHICH DO NOT REPRODUCE LEGIBLY.

CONFIDENTIAL

NAVWEPS REPORT 7652
NOTS TP 2676
COPY 51

DOWNGRADED AT 3-YEAR INTERVALS
DECLASSIFIED AFTER 12 YEARS
DOD DIR 5200.10

323734

CATALOGED BY ASTIA
AS AD NO.

**NOTES ON EXPERIMENTAL TECHNIQUES IN
AERODYNAMIC HEATING PROBLEMS**

(U)

By

L. R. Argabright, C. H. Johnson,
and
Warren K. Smith
Weapons Development Department

Released to ASTIA for further dissemination with
out limitation and the usual security
regulations.

ABSTRACT. This report contains a series of notes on experimental techniques used in applied research on aerodynamic heating problems. Tests in a radiant heating facility, construction and use of a free-flight test vehicle, and a simple thermocouple reference junction are described. (UNCLASSIFIED)

NOX



U. S. NAVAL ORDNANCE TEST STATION

China Lake, California

28 April 1961

CONFIDENTIAL

ASTIA

1961

1961

CONFIDENTIAL

U. S. NAVAL ORDNANCE TEST STATION

AN ACTIVITY OF THE BUREAU OF NAVAL WEAPONS

W. W. HOLLISTER, CAPT., USN
Commander

WM. B. McLEAN, PH.D.
Technical Director

CONTENTS

Foreword	111
Introduction	1
Section I. Construction of a Temperature-Telemetering Round, by C. H. Johnson and L. R. Argabright.....	2
Section II. Captive- and Free-Flight Tests of a Temperature-Telemetering Round, by L. R. Argabright and C. H. Johnson.....	21
Section III. Thermal Lag of Insulated Thermocouple Reference Junction Block, by Warren K. Smith.....	28
Section IV. Radiant Heating Tests of a Nose Cone, by Warren K. Smith.....	31

NOTS Technical Publication 2676
NAVWEPS Report 7652

Published by..... Weapons Development Department
Manuscript..... 40/MS 61-18
Collation..... Cover, 23 leaves, abstract cards
First printing..... 130 numbered copies
Security classification..... CONFIDENTIAL
Abstract alone..... UNCLASSIFIED
Title alone..... UNCLASSIFIED

THIS DOCUMENT CONTAINS INFORMATION AFFECTING THE NATIONAL DEFENSE OF THE UNITED STATES WITHIN THE MEANING OF THE ESPIONAGE LAWS TITLE 18, U.S.C. SECTIONS 793 AND 794. THE TRANSMISSION OR THE REVELATION OF ITS CONTENTS IN ANY MANNER TO AN UNAUTHORIZED PERSON IS PROHIBITED BY LAW.
REPRODUCTION OF THIS DOCUMENT IN ANY FORM BY OTHER THAN NAVAL ACTIVITIES IS NOT AUTHORIZED EXCEPT BY SPECIAL APPROVAL OF THIS STATION

CONFIDENTIAL

FOREWORD

This report is a collection of informal papers by various authors on the applied research effort at this Station in aerodynamic heating. Principal support for the work was received from the Bureau of Naval Weapons Task Assignment RMGA-53-406/216-1/F009-10-001 with some assistance from various development tasks.

The report is released at the working level for informational purposes only. It contains information which is still subject to modification or withdrawal.

LEROY RIGGS
Head, Aeromechanics Division

Released under
the authority of:

F. H. KNEMEYER
Head, Weapons Development Department

INTRODUCTION

A program of applied research in the problem of aerodynamic heating of guided missiles has been in progress as a funded task at the Naval Ordnance Test Station for the past three years. In addition to several relatively long-term major efforts, a number of investigations of smaller scope form a significant portion of this program. In many instances, these latter investigations grew out of or were extensions to work required for a specific development program. In these cases, the results were generally published in local informal reports of very limited distribution, or were submerged in a more extensive report concerning the related development task.

This report is one of several that are planned to provide easier access and wider distribution to the results attained in these investigations. These reports will each consist of a collection of notes on related topics gleaned from the informal reports which were published for local distribution only.

This report contains a group of notes on experimental techniques which have been used in the local research program. Experimental results have been included where appropriate to illustrate the use of the technique, or to indicate problem areas or scope of application.

SECTION I. CONSTRUCTION OF A TEMPERATURE-TELEMETERING ROUND

By

C. H. Johnson and L. R. Argabright

GENERAL DESCRIPTION

The temperature-telemetering round consists of all external hardware components of an operational missile (the Sidewinder IC configuration, Fig. 1) with exception of the warhead and fuse components which are replaced by the telemetering package and suitable adapters. It has two basic configurations:

1. A round with a thermocouple-instrumented dummy motor for captive flight tests, and
2. A round with a live motor for the captive/free-flight test.

An instrumented wing is interchangeable between the dummy motor and live motor.

The round is designed to respond to aerodynamic heat transfer as nearly like an operational missile as is practicable. Accordingly, alteration of the missile components for purposes of instrumentation is minimized, and all outside surfaces are the same as those of an operational missile, including the use of the same type and thickness of paint film. Thermocouple units imbedded in outside surfaces have low thermal resistance to the base material and are flush with these surfaces so that representative temperatures of the base material are obtained in these regions. Thermocouples fastened to inside surfaces are close-fitting low-mass units which closely follow temperature changes in the base material under unsteady-state flight conditions.

The telemetering system is an FM/FM system with commutated input to the single voltage-controlled subcarrier oscillator. A 30-segment low-level commutator, operating at a speed of 5 rps, alternately samples zero voltage and a thermocouple or calibration voltage in a make-before-break mode. In-flight calibration is accomplished by applying low-level voltages to three commutator segments from a voltage divider network excited by a zener-diode regulated supply. Nine thermocouple outputs are commutated as well as the calibration voltages. The commutator output is amplified by a transistor amplifier with a gain of 1,000 and applied to a single 70-kc $\pm 15\%$ deviation subcarrier oscillator which modulates an FM transmitter.

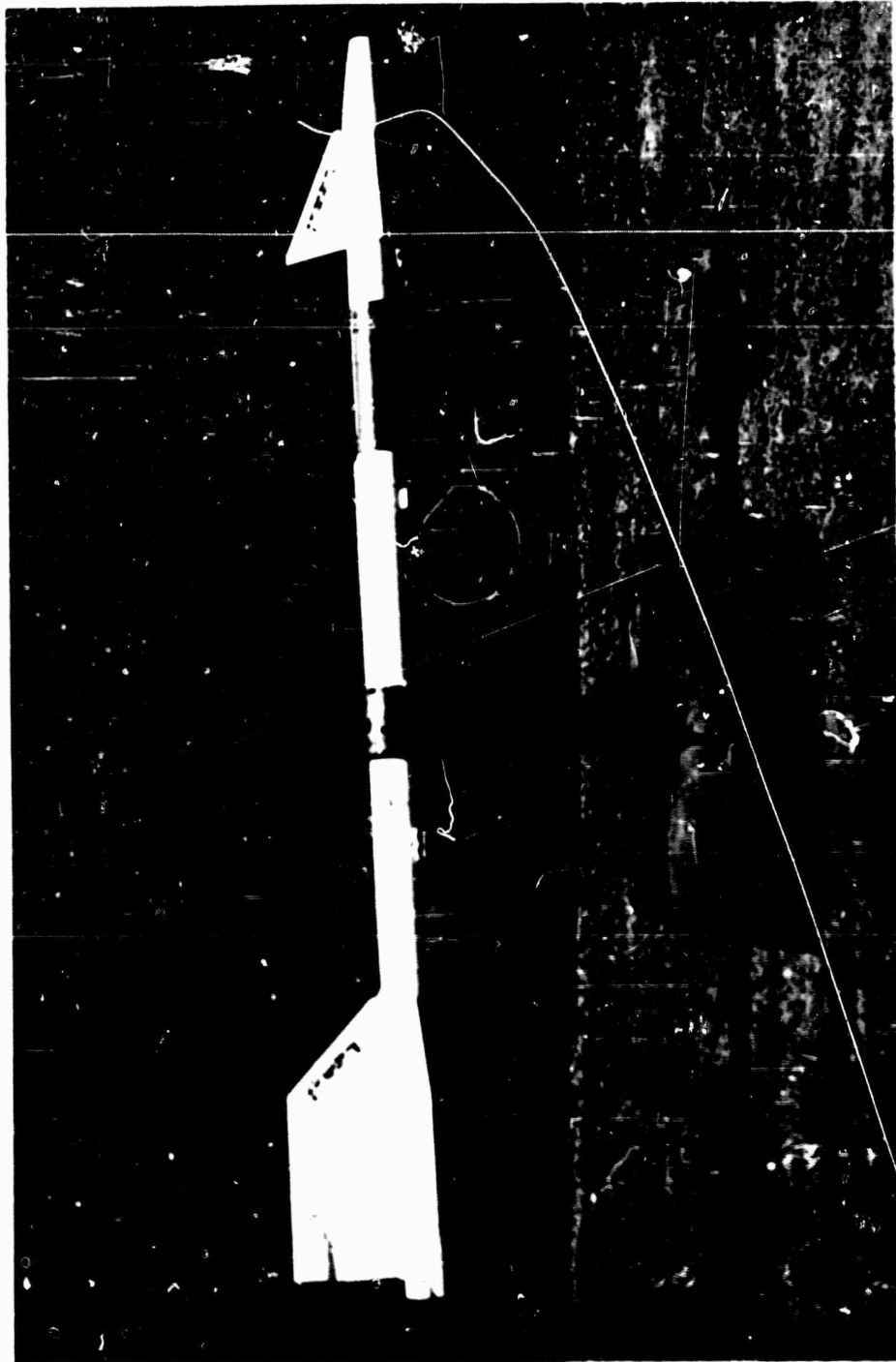

FIG 1 Sidewinder IC Temperature-Telemetering Round (Captive)

CONSTRUCTION & ASSEMBLY PROCEDURES, GUIDANCE & CONTROL SECTION

Table 1 is a description of materials that are used but not sufficiently identified in these construction and assembly procedures.

The sequence of operations used in the construction of the guidance and control (G&C) section of the temperature-telemetering round is diagrammed in Fig. 2 and supplements the following description.

TABLE 1. Material Description

Item	Description
Thermocouple Wire	<p>30-gauge duplex Chromel-Alumel wire ISA calibration K doublewrap Fiberglass over each conductor and Fiberglass over-all covering with silicone varnish impregnation. Color brown over-all, Chromel (+) leads yellow, and Alumel (-) leads red.</p> <p>Note: The single conductor insulation in this wire unraveled very easily when the over-all covering was removed and made it difficult to keep the leads protected. The following brands are considered superior for this application:</p> <ol style="list-style-type: none"> 1. Pyco thermocouple wire, grade K-30-A6 with silicone varnish asbestos over each conductor and silicone varnish braid over-all for 950° to 1000°F service. Furnished by Pyrometer Corporation of America, 2030 W. 16th Street, Long Beach, Calif. 2. Thermocouple wire GG-30-CT with Fiberglass over-all and Fiberglass over each conductor, with 21 high-temperature varnish for 950°F service. Furnished by Thermoelectric Co., Inc., Saddlebrook, N.J.
Electrical Tape	<p>Scotch Electronic Tape No. 28; acetate cloth thermosetting, pressure sensitive. Furnished by Minnesota Mining and Manufacturing Co.</p>
Paint	<p>White acrylic nitrocellulose lacquer MIL-L-19537, color 511. Furnished by Trail Chemical Corporation, El Monte, Calif.</p>
Silver Paste (dome thermocouple contact)	<p>Wegge Silver Metallizing Paste F-1510B. Furnished by Western Gold and Platinum Co., Belmont, Calif.</p>
Epoxy (thermocouple units)	<p>(1) Epocast No. 902 with No. 951 catalyst mixed 10:1 part by weight (2) Epocast No. 104 with No. 951 catalyst mixed 10:1 part by weight. Furnished by Furane Plastics Co.</p>
Sealant (connector potting)	<p>Resin No. EC 141B with catalyst No. EC 141A mixed 5:1. Furnished by Minnesota Mining and Manufacturing Co.</p>
Foam Resin (G&C filling)	<p>"Scotchcast" Brand Resin No. 60. (Polyurethane) closed-cell structure, 7 lb/ft³ density, foamed at 110-130°C in 1 hour. Furnished by Minnesota Mining and Manufacturing Company.</p>
Concrete (dome/housing assembly)	<p>E-Anchor 14630 adhesive cured at 300°F for 3 hours. Furnished by Rubber and Asbestos Corp., Bloomfield, N.J.</p>

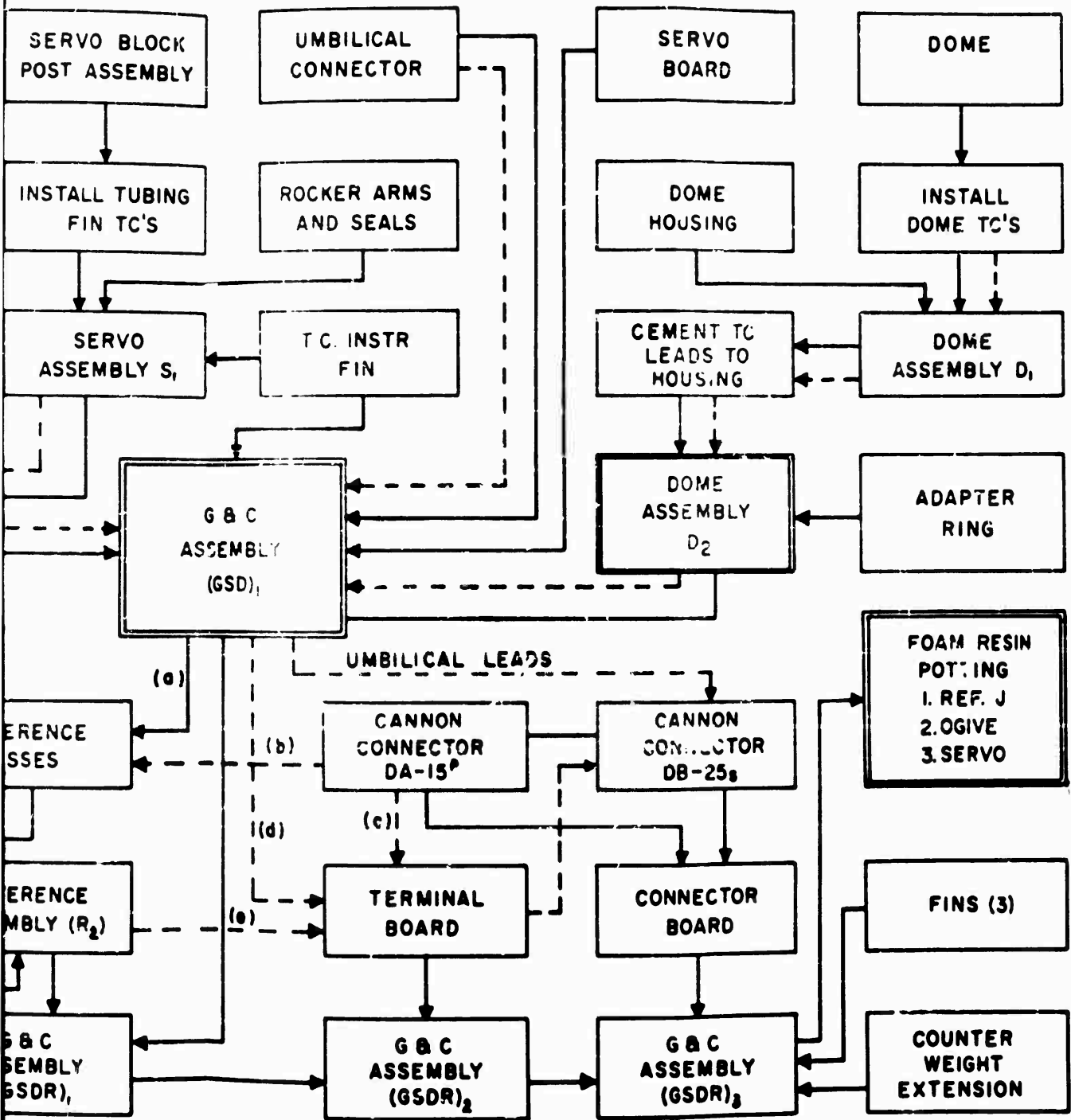

2

(b) ALUMEL LEADS (c) CHROMEL LEADS (d) TC CHROMEL LEADS (e) THERMISTOR & TC ALUMEL LEADS

Guidance and Control Section Assembly Procedures.

Dome Thermocouple Groups

Three thermocouples were constructed and installed in the dome on the inside surface as shown in Fig. 3. Prior to installation of the thermocouples, the dome was cemented to the molded plastic housing with Bondmaster cement, and the assembly was cured at 300°F for 3 hours.

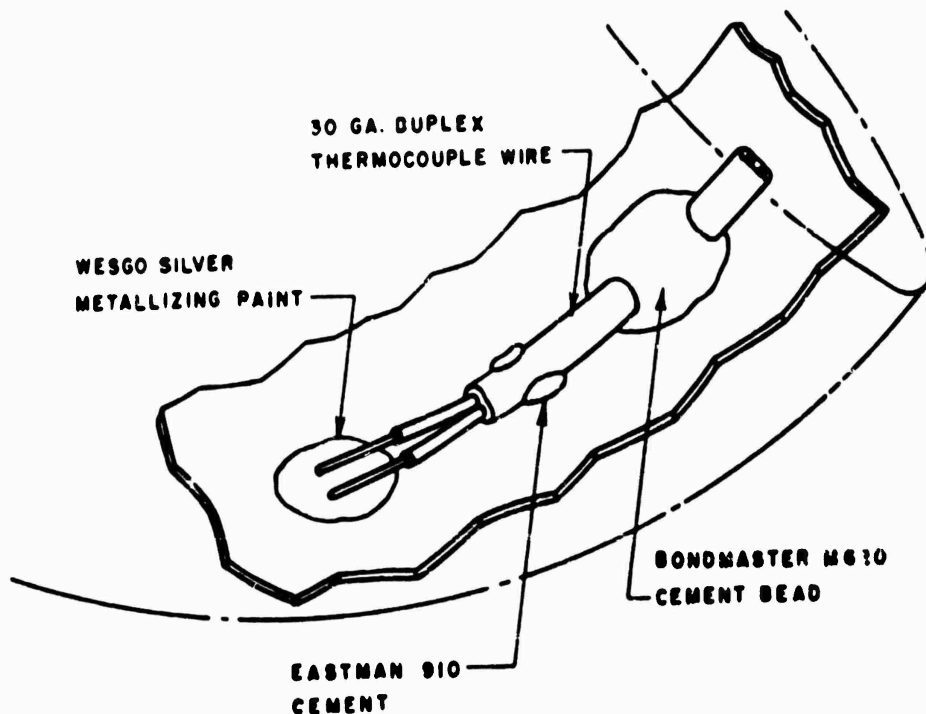

FIG. 3. Dome Thermocouple Installation.

The construction and installation procedures for these thermocouples were as follows:

1. About $3/8$ inch of the over-all insulation and $1/4$ inch of single conductor insulation were removed from one end of each 4-ft length of duplex thermocouple wire. The exposed wires were cleaned thoroughly with emery cloth and aligned parallel to each other about $1/32$ inch apart.
2. The interior of the dome/housing assembly was carefully cleaned with acetone.
3. Thermocouple leads were shaped within the dome-housing assembly with the cleaned wires positioned against the point where temperature was to be measured. This end of the lead was secured to the

dome surface using Eastman 910 cement applied at the end of the thermocouple over-all insulation. The procedure was repeated for the other thermocouple leads, bringing them to a common junction in the dome housing ready for passage to the rear of the G&C unit. The leads were then clamped to the side of the housing.

4. Enough silver metallizing paint was applied to the cleaned wires and the adjacent dome interior to wet the bare wires and an area of the dome 1/4 inch in diameter. About 30 min. was allowed for the paint to dry sufficiently for handling of the dome-housing assembly.

5. A small bead (about the size of a match-head) of cement was placed at several points along each thermocouple lead, wetting both the lead and base material.

6. The assembly was carefully supported in an oven with the dome-housing interface horizontal and cured at 300°F for 3 hours.

Ogive Thermocouple Group

Two thermocouples were located inside the ogive. These thermocouples, as well as those in the fin, wing, and aft telemetering (TM) adapter were all constructed in the same manner, although the disc sizes differed slightly. These thermocouples were constructed as follows:

1. Discs of the required sizes were punched from Type 302 austenitic stainless-steel sheet and pressed to reduce burrs and convexity due to punching. Several passes were made over emery cloth with the disc concave (burr) side down using light finger pressure. All discs were degreased before welding.

2. Segments of duplex thermocouple wire were cut, each with at least 1 foot of excess length. Both ends of each piece were prepared by removing about 3/8 inch of outer (brown) insulation and about 1/4 inch of the single conductor insulation. The exposed wires at one end were carefully cleaned with emery cloth to remove all enamel or other coating material.

3. The cleaned thermocouple wires of each duplex lead were spot-welded to a stainless-steel disc with the wires placed about 1/16 inch apart and extending about two-thirds across the disc. The correct spot welding procedure was found by running tests on sample pieces before making up the model thermocouples.

The procedures for the installation of the ogive thermocouples (Fig. 4) were as follows:

1. The surface areas where thermocouples were to be placed in

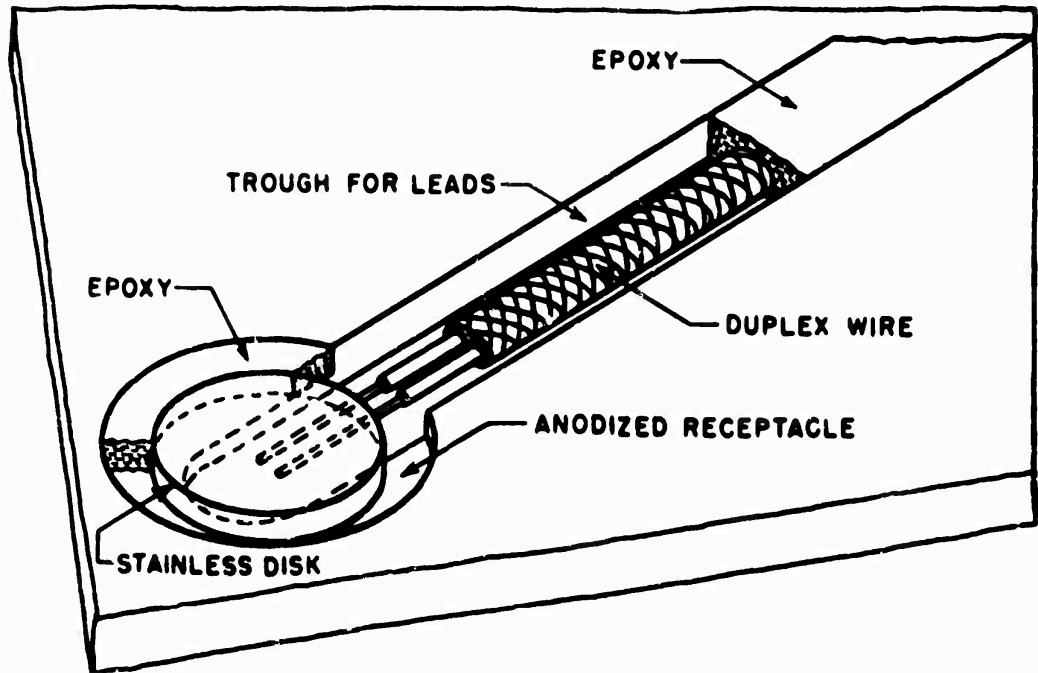



FIG. 4. Fin Thermocouple Installation.

the G&C housing were washed with acetone and left unsmoothed to improve thermocouple adhesion.

2. A very thin coating of Epocast (Table 1) was applied to the desired area, making a patch about 1 inch in diameter, and allowed to harden (cure). The purpose of this coating was to minimize the possibility of thermocouple grounding to the G&C housing.

3. A coating of Epobond was then applied over the first coating of Epocast and the thermocouple disc set into this coating, against the ogive interior. About 1/2 inch to 3/4 inch of the leads next to the disc were covered with a 1/16-inch layer of Epobond.

4. A piece of spring wire was bent thusly: . After insulating the end not to be placed on the thermocouple disc, the spring was compressed and placed inside the ogive section against the thermocouple disc to hold it firmly against the ogive wall during epoxy cure. Special care was taken to prevent the disc from sliding out of place.

5. Immediately after setting the spring load and before the epoxy could harden, both conductors were tested for grounding to the G&C

housing with an ohmmeter. Grounding was indicated by low resistance (up to several ohms); however, a high resistance (over several hundred ohms) was sometimes observed due to some conductance of the uncured epoxy. Grounded thermocouples were reinstalled.

6. After the Epobond had cured, the spring load was removed and the unit tested again for thermocouple grounding.

Because of the tackiness of uncured Epobond, some trouble was experienced in setting the thermocouples without smearing the epoxy over areas where it was not wanted. Similar methods described later indicate that coating with heavy silicone grease around the first epoxy patch will help in removing excess cured epoxy after the thermocouple mounting operation. Also, the sensor and uncured epoxy can be covered with thin teflon sheet (non-adherent to cured epoxy) backed by a hard rubber block before spring-loading the system to produce a neater thermocouple installation.

Fin Thermocouple Group

The fin was inletted to allow flush mounting of the thermocouples and associated leads. Before thermocouple installation, the fin was heavily anodized (colored) to further reduce grounding possibilities without appreciably affecting their thermal conductance between the fin and disc. The color provided a visual check on the anodized surface.

Thermocouple assemblies similar to those installed in the ogive were used; however, the disc diameter was 3/16-inch instead of the 1/4-inch diameter used in the ogive and aft TM adapter assemblies. The 3/16-inch diameter disc allows 1/32 inch radial clearance between the disc and the fin material in order to reduce the possibility of thermocouple grounding. In these thermocouple assemblies, the brown over-all insulation layer was removed up to the fin mounting boss, leaving individually insulated wires about 0.020 inch diameter each which readily fitted into the fin grooves. The procedures for the fin thermocouple installation (Fig. 5) were as follows:

1. A thin coating (estimated 0.002 inch thickness) of Epocast was applied to the cavity in which the thermocouple disc was to be placed, and allowed to harden.
2. A small amount of Epobond was then applied to the same cavity for a distance of about 1/2 inch along the groove.
3. The thermocouple disc was placed in its cavity with the thermocouple leads lying in the fin groove.
4. A piece of thin teflon sheet several inches square was carefully laid over the disc and surrounding area.

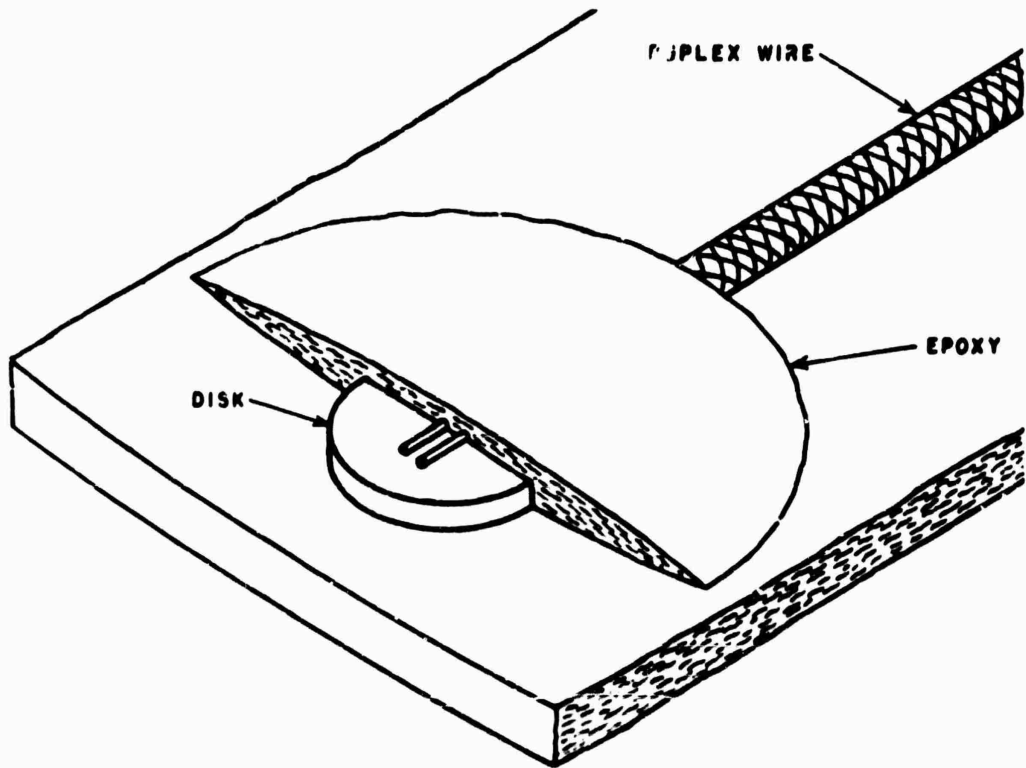

FIG. 5. Inside Surface Thermocouple Installation.

5. A wood tongue depressor was placed over the teflon sheet and clamped securely against the fin surface. Care was taken not to move the disc in its cavity or to allow any epoxy-coated thermocouple wire to project above the fin surface. The disc itself projected about 0.003 inch above this surface. The installation was tested for grounding before the epoxy was allowed to harden.

6. After the epoxy hardened, the thermocouple was again tested for grounding.

7. The teflon sheet was removed, and the thermocouple wire was set in the fin groove along its full length using the same procedure as above. All excess uncured epoxy was carefully removed from leads at the ends of the grooves to avoid breaking the wire after curing.

8. Excess hardened Epobond was carefully removed from the fin surface, and the thermocouple disc was made flush with the surface using emery cloth.

To facilitate removal of excess epoxy, it may be helpful to apply a thin layer of heavy silicone grease on the fin surface in the general

area, but not closer than about 1/2 inch to the groove. In installing thermocouples in the prototype model fins, it was found that a thin layer of epoxy was spread out over a fairly large area as a result of the tight clamping, and considerable sanding was needed to remove this material.

Ogive Tubing

A 20-inch length of 1/4-inch I. D. Teflon tubing was positioned longitudinally in the ogive (Fig. 6) so that it passed directly through the by-pass notch cut into the counterweight (described below) and on toward the aft end of the G&C unit. Leads from the ogive thermocouples were each bent in a loop against the ogive inside wall to determine where they should enter the tubing. When these points were determined, the tubing was taken out and longitudinal slits about 1/2 inch long were cut at each position. One ogive thermocouple lead was fed into each slit with the leads running toward the servo section. Later in the assembly procedure, the dome thermocouple leads were also fed into the forward end of the tubing and back into the servo section. The tubing was then re-positioned in the ogive and taped securely in place.

Counterweight

The counterweight makes up the required weight of the G&C unit resulting from omission of the electronics package, seeker and servo components. The counterweight is placed in the G&C housing and secured with four flat head screws. The ogive tubing passes through its by-pass notch.

Counterweight Extension Installation. A counterweight extension was not used in most of the captive flight tests, but was installed only to increase the static margin of the locked-fin round for free-flight.

Servo Block, Post, and Dummy Piston Assembly

Dummy pistons were installed in the servo block and post assembly and secured in place by bolts screwed into tapped holes in the servo block under each piston. Fin and rocker arm assemblies were then mounted on the block and post assembly and the fins aligned and locked in place by adjusting the bolts. The servo block and post assembly was temporarily positioned in the G&C housing to determine where thermocouple leads from the instrumented fin must be routed to carry them through the by-pass notch in the servo block and on to the rear of the G&C housing. When this was determined, the servo was removed and two pieces of 1/8-inch I. D. teflon tubing wire was run through the by pass notch in the servo block, up a post and across to the post nearest the port through which the instrumented fin boss would pass. The rocker arms were then mounted on the servo assembly, and the teflon tubing pieces were secured by tape to the appropriate rocker arm so that each thermocouple lead from the fin could be fed through the tubing to the rear of the G&C section without any danger of binding.

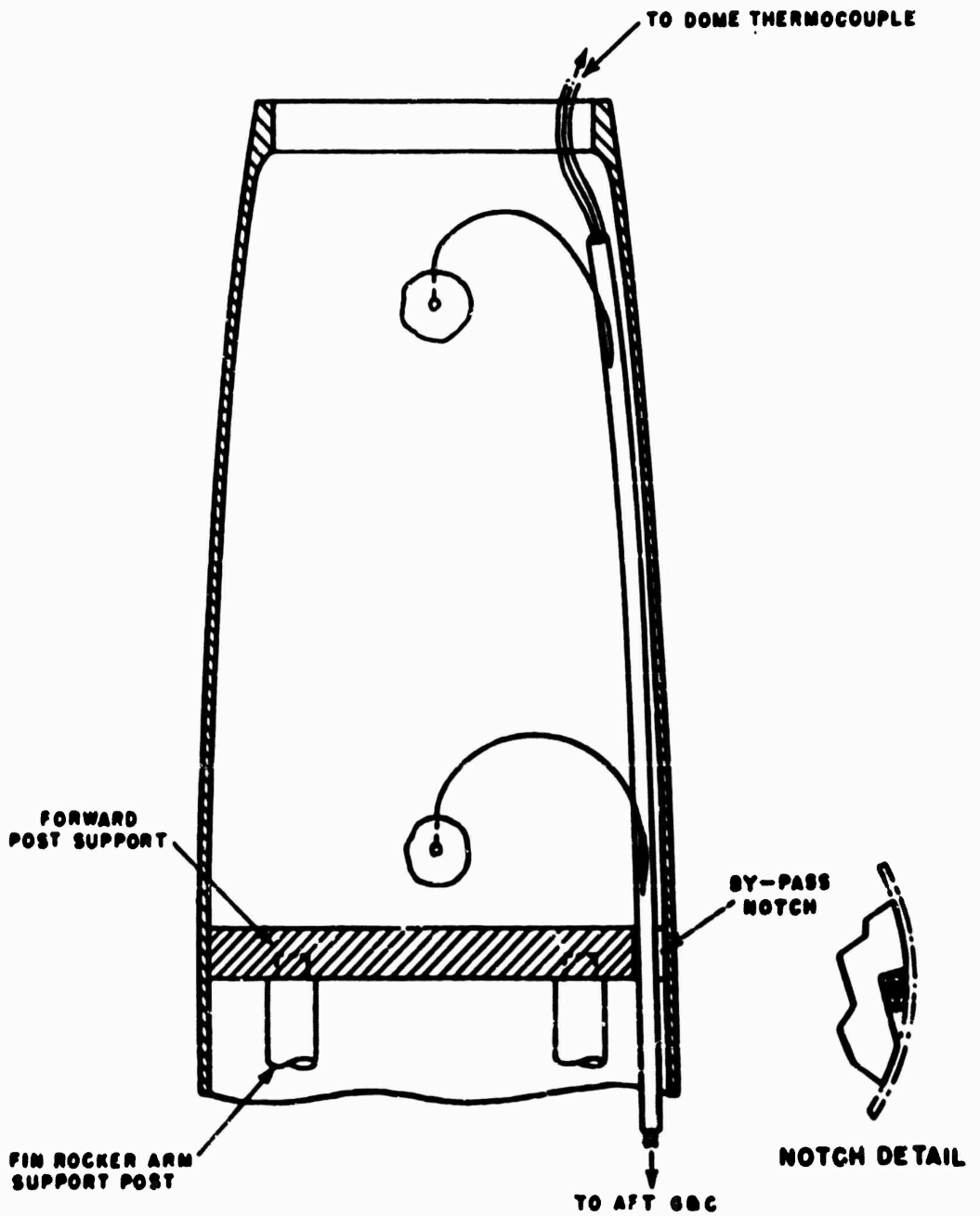

FIG. 6. Ogive Thermocouple Installation.

Rocker arm seals were put in place and the entire servo assembly repositioned in the G&C housing with the post tips inserted into the clearance holes drilled in the counterweight. The servo assembly was then secured to the G&C housing at the servo block.

Both fin thermocouple leads were fed into their respective teflon tubes on the rocker arm. The fin was then fastened to the rocker arm, and the leads were pulled through the tubes from the rear of the G&C unit as the fin was put in place and secured. Exposed thermocouple leads on the fin/rocker arm area were taped down tightly, and the rocker arm seals were secured to the G&C housing.

Installation of the Dome Assembly

The dome and housing assembly with thermocouples attached was cemented to the housing adapter. The dome thermocouple leads were fed through the ogive tubing until the dome assembly and G&C housing were separated by about 8 inches. The thermocouple leads were secured from moving in the ogive tubing, the excess leads were coiled in the dome assembly, and this assembly was then secured to the G&C housing by means of flat head screws, which permit repair of thermocouples if necessary.

The ogive section was filled with foam resin at this stage. The later addition of the counterweight extension required removal of the foam resin.

Temperature Reference Junction Assembly

A micarta servo board was placed against the servo block with the teflon tubing carrying thermocouple leads passing through its by-pass notch. The umbilical connector was then installed with approximately 8-inch lengths of the required internal leads soldered in place.

A temporary assembly of reference junction components was made to determine a convenient length for the G&C thermocouple and umbilical leads. These leads extended about 6 inches beyond the end of the G&C section. Shorter leads would have made soldering and spot welding awkward, whereas longer leads would have presented a storage problem during final reference junction assembly because of the small space available.

The teflon tubes carrying G&C thermocouples were cut about 2 inches above the servo board. The brown over-all insulation was removed from each of the thermocouple leads down to the point where they touched the base of a notch in the micarta junction support. The Alumel (red insulation) and Chromel (yellow insulation) leads then extended about 5 inches from the notch. About 1/2 inch of the individual wire insulation was then stripped from the end of each wire in this thermocouple group, and the exposed wire was thoroughly cleaned with emery cloth.

Ten 5-inch lengths of Chromel wire of the same calibration as the duplex material wire were stripped of insulation 1/2 inch from each end, and the ends were cleaned with emery cloth. These pieces were to be used later for the positive side of the reference masses.

Three 6-inch lengths of duplex wire of the same calibration were cut for the aft thermocouple group. About 1/2 inch of the over-all insulation, and 1/4 inch of the single conductor insulation were removed from one end of each 6-inch length of duplex wire; about 3 inches of the over-all covering and 1/2 inch of single conductor insulation were removed from the opposite end. All bare ends of the leads were thoroughly cleaned with emery cloth.

The lead preparation described above takes care of all thermocouple circuits up to the terminal board.

Junction Block Preparation

The junction block was anodized with a heavy coat to reduce the possibility of short-circuiting between reference masses and to electrically isolate the thermistor from the junction block.

Thermistor Calibration. The General Electric No. D204 Type R thermistor used for monitoring the reference block temperature during flight was calibrated in a water bath since the nominal thermistor resistance (125 ohms at 24°C) is small compared to interlead resistance of the water path. Bath temperature changes ranging from 40° to 110°F were made using ice and electric heating units. Temperatures were measured with a mercury thermometer, and thermistor resistance was measured using an ESI Model 250 impedance bridge.

Thermistor Installation. Teflon tubing was fitted over each thermistor lead and the leads were soldered to 24-gage teflon-insulated stranded copper wire. The thermistor was inserted in the junction block and potted in place with Epocast 502, with the lower ends of the teflon tubing also being secured by the epoxy. An electrical check after hardening of the epoxy showed the thermistor isolated from the junction block.

Preparation of Junction Block Holes for Reference Masses. First attempts to install the reference masses in the junction block without grounding to the block were not completely successful due to penetration of the anodized film by the sliding masses. It was found that heavy silicon grease applied to the hole inside surfaces and the sides of the reference masses eliminated grounding, if the masses were not moved excessively.

Reference Mass Preparation

The ten steel reference masses were degreased and one of the 5-inch lengths of Chromel wire was spot welded to the flat which was milled on the side of each mass. Each lead extended about two thirds the length of the flat and was displaced about 1/16 inch from its centerline.

The Alumel wire of each of the three 6-inch lengths of duplex wire (aft thermocouple group) was welded to a reference mass with the wire aligned parallel to and about 1/8 inch from the Chromel wire. Alumel wires from the G&C thermocouple group were welded in the same way to the remaining seven reference masses.

Seven of the reference masses were now connected to the G&C unit. To reduce flexing of the leads which resulted in wire breakage at the reference masses several times, the masses were taped to the outside surface of the G&C housing in the order of their circuit number. They could then be removed individually as needed.

Thermocouple Connections to the Terminal Board

All free ends of the thermocouple circuits were Chromel wire at this stage. These ends were completely tinned with resin core solder over the 1/2-inch length. Each wire was then wound two revolutions around its designated pin on the terminal board and soldered in place. The terminal board was arranged so that the pair of leads from a reference mass went to the adjacent pins to minimize any parasitic EMF due to temperature differences between pins.

Installation of Reference Masses in Junction Block

In preparation, the G&C section was supported with the aft end up. The junction support was set in place on the servo board with the slots for wire passage aligned with the umbilical connector. The junction block was then inserted in the junction support and secured to it by means of screws at the sides.

All reference masses were first passed through the hold in the junction cap and then each was carefully inserted in a hole in the junction block. The thermistor leads were fed back through the junction cap for later connection to the terminal board. The cap was then fastened to the junction block. After testing to insure that all masses were electrically isolated from each other and the junction block/cap assembly, the masses were immediately potted in place using Epocast 502.

After the epoxy had hardened, the terminal board was fitted into the junction support and the excess wire carefully folded into the small space between the junction cap and terminal board.

Final G&C Assembly

All umbilical leads were passed through the center hole of the connector board and were soldered to their proper pins on a Cannon connector. Teflon-covered stranded copper wire was then soldered to terminal board pins, passed through the connector board, and soldered to the correct Cannon pin. Finally, wires for the aft thermocouples were passed through the off-center hole of the connector board and soldered to the proper pins of a second Cannon connector. After potting the leads around the rear of the connectors, both connectors were fastened to the connector board.

When electrical checks showed that no grounding nor short circuiting existed, the connector board and forward TM adapter were secured to the G&C housing.

Application of Foam Resin

Foam resin was used in the G&C section for three reasons: (1) to insulate the reference junction from changes in the missile external temperature, (2) to minimize vibration of wires which ultimately would lead to fatigue failures, and (3) to reduce air flow inside the unit during flight tests.

"Scotchcast" resin was used as the foam material because the powder is more readily handled in this application than liquid raw materials, and the curing temperature is comparatively low (130°C).

The reference junction, servo, and ogive regions were foamed separately at different stages of G&C assembly, with each operation taking approximately 6 hours; however, all portions could have been foamed in one operation since the expansion ratio was found to be fairly reliable, and appreciable underfilling or overfilling did not occur.

MOTOR THERMOCOUPLE INSTALLATION

The motor has two stages in which only the first or booster stage has an insulated motor-tube liner. Since the sustainer grain would be more rapidly heated than the booster grain in high-speed captive flight, all motor thermocouples were placed in a dummy sustainer grain. This inert motor was equipped with two thermocouples placed 180 deg apart in the dummy grain, each about 0.040 inch below the surface and 11.25 inches from the forward end of the grain. An additional thermocouple, made up as a 3/16-inch diameter stainless-steel disc assembly similar to those used in the wing, was placed adjacent to each of the original thermocouples, making two pairs 180 deg apart. Each new thermocouple was placed in a 3/16-inch diameter by 0.010-inch deep cavity milled into the grain surface; the wires were carried away in a groove for about 1 inch before entering a hole drilled into the grain perforation. The thermocouple discs were held in place with cellophane tape wrapped

around the grain.

The dummy second-stage grain was secured by a screw passing through the motor wall and into the grain to prevent rotation in flight.

WING THERMOCOUPLE INSTALLATION

Two thermocouples were installed in the grooved wing using a procedure similar to that used for the fin. In the case of the wing, however, the disc inlet is on one side of the wing and the wire groove on the other. This construction was used because of the small wing thickness at the places where the thermocouples were installed.

Next, a conduit was formed from 3/16-inch I. D. aluminum alloy tubing running along the wing surface about 1.5 inches above the root, along the motor tube and into the aft TM adapter at the TM unit and adapter joint. The wing thermocouple leads were pulled through this conduit and into the adapter until only small loops of thermocouple leads remained exposed on the wing surface. A fairing strip was formed of 2-inch wide aluminum sheet over the conduit on the wing and extended several inches beyond the end of the conduit. The wing was drilled and tapped for screws, and the fairing was drilled with matching clearance holes.

Epobond cement was then applied to all exposed thermocouple leads and the entire area to be covered by the fairing strip. The fairing strip was secured to the wing by fillister head screws, and the excess Epobond was removed from the wing surface. After the Epobond hardened, emery cloth was used to smooth the surface and blend it into the wing.

The conduit was secured to the motor tube at three places by means of "Bandit" stainless-steel bands 1/2 inch wide.

Leads from the wing thermocouple were soldered to pins of a Cannon connector.

AFT TM ADAPTER THERMOCOUPLE

Installation

One thermocouple was installed in the aft TM adapter using a procedure similar to that used in installing the G&C housing (ogive) thermocouples. The leads from the adapter thermocouple were soldered to pins of a subminiature connector.

Connection

Thermocouple signals aft of the TM package were picked up by two connectors mounted at the rear of the TM package. Chromel-Alumel leads ran from the aft connectors directly through the TM package

forward to pins of another connector. This connector was plugged into its mating connector mounted on the reference junction connector board.

Three thermocouple outputs aft of the TM package were permitted in any one flight by the telemetering round design. The adapter thermocouple was connected into the TM system for every flight, and the remaining two outputs were selected from the wing or motor-grain thermocouples. On the firing run, the wing thermocouples were used.

Painting

In all captive-flight testing, the round (shown in Fig. 1) was painted glossy white over the G&C section, motor aft TM adapter assembly, and wings, and the TM package was painted fire-orange.

For the firing run, a roll patterned (fire-orange--saturn-green) live motor was used with the wings painted fire-orange over-all except in the region of the thermocouples. The painting of the G&C section and the TM package was left unchanged.

TEMPERATURE CALIBRATION PROCEDURE

The purpose of the calibration tests was to check the response of the round under heating and cooling conditions, and to verify that correct temperatures were indicated by the thermocouples. Only the G&C section was tested in this manner. The aft round thermocouples were replaced by duplicate thermocouples located adjacent to the G&C section as an additional temperature check.

The G&C section was placed in a refrigerator-oven controlled by a Brown Electronic recorder. A mercury thermometer visible through the oven door was placed with the bulb about 3 inches above the G&C section.

Leads of the three thermocouples representing aft thermocouples of the complete round were soldered to pins of a Cannon connector, which was plugged into the mating reference junction connector. Long copper leads were soldered to pins of another connector which was also plugged into its mating reference junction connector, the leads being carried through the oven wall to a terminal strip. Each contact pair of the terminal strip receiving a thermocouple output was then connected to a L&N-thermocouple 10-point-selector switch, the output of which was connected to the y-coordinate contacts of a Moseley A3 x-y recorder. The reference-junction thermistor leads were connected to a zener-diode regulated source through a large dropping resistor to obtain about 5 mv output from the thermistor at room temperature. Voltage was applied across the thermistor through the selector switch only when readings were to be made, to minimize thermistor self-heating.

When a convenient time base (x-axis) and y-axis sensitivity were established, a y-axis calibration was run using the output of an L&N potentiometer. The cooling (or heating) cycle was started by setting the Brown controller to the required temperature setting, and thermocouple and thermistor readings were made at convenient intervals depending on the temperature rate of change. These readings were recorded on the Moseley instrument by rotating the selector switch at a one-channel/sec rate. In these tests, 10 records/inch were obtained.

Approximately 4 hours were required for most thermocouples to approach the oven equilibrium temperature within 3°F. At the higher temperatures and long heating periods, the reference junction began to change temperature rapidly--112°F maximum temperatures were recorded which restricted the maximum oven test temperature to 200°F. (This effect, however, was never a problem in the aerodynamic heating tests because of their short duration.) The refrigerator-oven tests were run at equilibrium temperatures of 40°, 100°, and 200°F.

The conversion of the Moseley recorder data (EMF) to temperatures was performed as follows:

1. The EMF data for the reference junction thermistor were converted into temperature, °F, using the previous water-bath calibration.
2. The thermocouple EMF data were converted into temperature data, °F, from a standard temperature-versus-EMF table for K-calibration Chromel-Alumel thermocouples.
3. The thermistor and thermocouple temperatures were algebraically added to determine each test junction temperature.

Within the temperature range of these tests, which extended over most of the range observed in captive-flight conditions, the round equilibrium temperatures in all cases agreed within 3°F of the oven temperature as indicated by independent thermocouples and mercury thermometers.

SECTION II. CAPTIVE- AND FREE-FLIGHT TESTS OF A TEMPERATURE-TELEMETERING ROUND

By

L. R. Argabright and C. H. Johnson

INTRODUCTION

Seven captive-flight tests were made of a temperature-telemetering round (described in Section I) mounted on a F-104 aircraft to determine temperature profiles experienced by a missile carried on a Mach 2.0 aircraft. The test program culminated in the firing of the round during the final flight.

The data obtained appear to be nearly complete and generally of excellent quality. Analysis of the data has not been completed and, hence, will be reported in a separate publication. This section discusses the experimental aspects of the program and presents examples of the data obtained.

TEST MODEL

Extent of Simulation

The external configuration of the model (shown in Fig. 1, Section I) was that of the Sidewinder 1C except for the addition of a small external tube through which the wing thermocouple wires ran to the telemeter unit and the use of dummy rollerons instead of real ones.

Internally, several compromises were necessary in order to accommodate the instrumentation. The fins were mounted on the standard rocker arms and installed on the servo block and post assembly. However, fixed dummy pistons were used, and there were no electronics package nor seeker components. Structural adapters were required at both ends of the telemeter unit to mate it with the missile hardware. The dummy motor used in the captive tests was loaded with a dummy grain whose thermal simulation of a live motor is not well established.

An unforeseen variation in captive- and free-flight simulation arose when, after most of the captive tests, it was determined that a weight had to be added near the nose to increase the center-of-gravity to center-of-pressure separation for fixed-fin flight. This changed the thermal capacity and thermal path in the ogive section and resulted in a noticeable change in thermal response in that area.

Instrumentation

Chromel-Alumel thermocouples were installed at selected locations as listed in Table 2 and indicated in Fig. 7. Thermocouple units imbedded in outside surfaces had low thermal resistance to the base material and were flush with the surface so that representative temperatures of the base materials were obtained. Thermocouples fastened to the inside surfaces were close-fitting low-mass units which were capable of closely following temperature changes in the base material under unsteady-state flight conditions.

TABLE 2. Location of Thermocouple Junction

Channel No. ^a	Thermocouple Junction	Internal Connection	Location	Orientation ^b , deg
6	Dome No. 1	Permanent	Dome inside surface, 0 deg from dome center	---
7	Dome No. 2	Permanent	Dome inside surface, 35 deg from dome center	90
7'	Dome No. 3	Not connected	Dome inside surface, 80 deg from dome center (at dome edge)	270
8	Ogive, Fwd	Permanent	GhC housing inside surface, Sta. 4.1 (in.)	60
9	Ogive, Aft	Permanent	GhC housing inside surface, Sta. 11.0 (in.)	60
10	Fin, Fwd	Permanent	Surface 1/4 inch from leading edge (on surface opposite umbilical)	135
11	Fin, Aft ^c	Permanent	Surface 1/4 inch from leading edge (on surface opposite umbilical)	135
12	Grain No. 1-1	Connector ^d	11.25 in. from MCB ^e /motor junction, 0.040 inch deep	90
13	Grain No. 1-8		11.25 in. from MCB/motor junction, surface	90
12''	Grain No. 2-1	Connector ^d	11.25 in. from MCB/motor junction, 0.040 inch deep	270
13''	Grain No. 2-8		11.25 in. from MCB/motor junction, surface	270
12'	Wing, Fwd	Connector ^d	Surface 1/4 inch from leading edge (surface opposite umbilical)	135
13'	Wing, Aft ^c		Surface 1/4 inch from leading edge (surface opposite umbilical)	135
14	Aft Adapter	Connector	Inside surface at mid-length, Sta. 41.25	180

^aReferring to Fig. 7.

^bOrientation counterclockwise from umbilical facing forward.

^cPaint removed from surface of temperature-sensing disc on free-flight test.

^dOnly one pair of thermocouples in temperature-measuring system for each flight. Wing thermocouple pair used in free-flight test.

^eMotor Control Box.

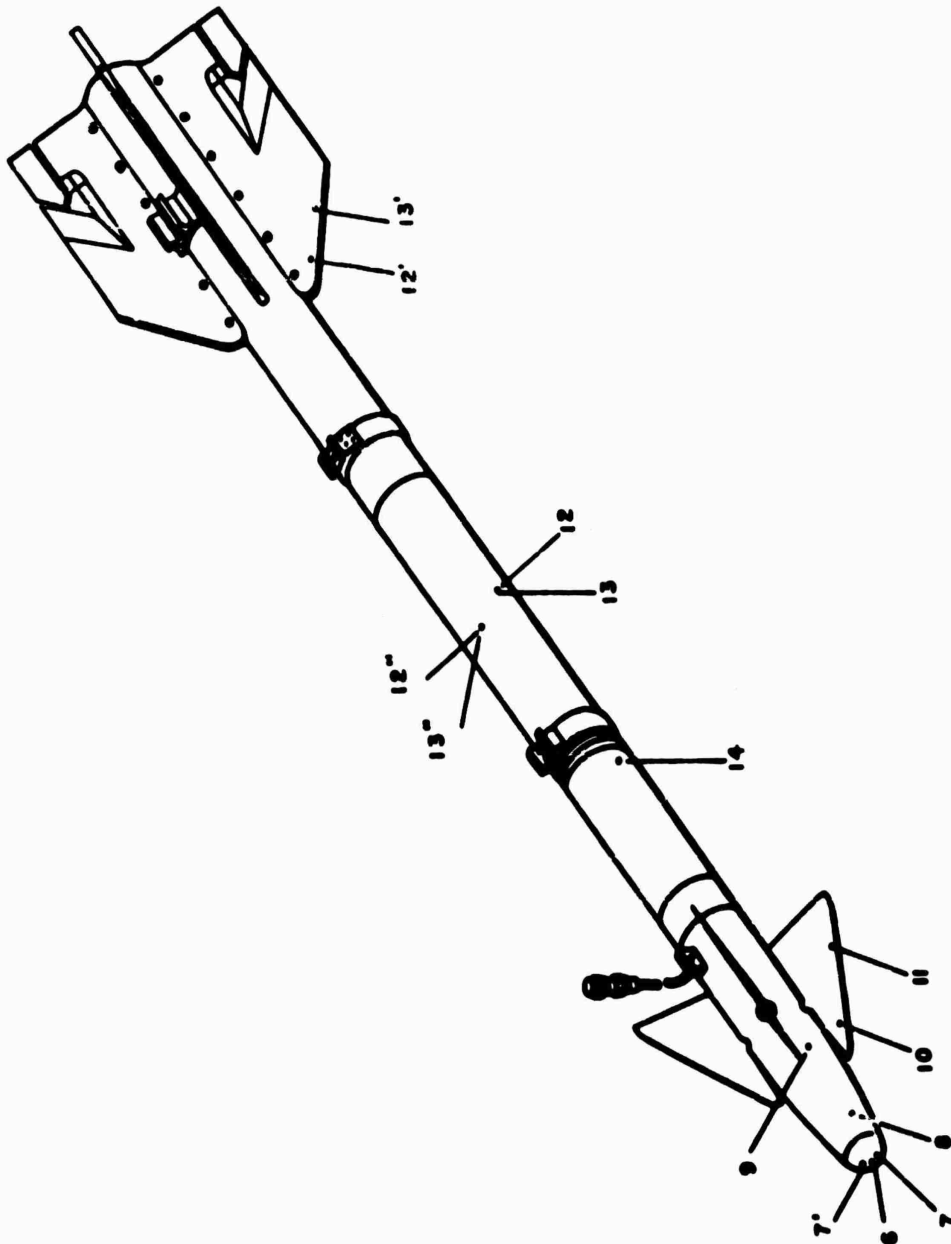

FIG. 7. Thermocouple Channel Numbers for the Temperature-Telemetering Round.

The telemetering system was an FM/FM system with commutated input to a single voltage-controlled subcarrier oscillator. A 30-segment low-level commutator, operating at a speed of 5 rps, alternately sampled zero voltage and a thermocouple or calibration voltage in a make-before-break mode. In-flight calibration was accomplished by applying low-level voltages to three of the commutator segments from a voltage divider network excited by a zener-diode regulated supply. Nine thermocouple outputs were commutated as well as the calibration voltages. The commutator output was amplified by a transistor amplifier with a gain of 1,000 and applied to a single 70-kc $\pm 15\%$ deviation subcarrier oscillator which modulated an FM transmitter. After the captive flights, the sensitivity and temperature range was adjusted to accept the higher level signals expected on the firing flight.

FLIGHT TEST PROGRAM

The original philosophy of the flight test program called for reaching two objectives: (1) imposing, as nearly as possible, a step temperature increase on the missile to determine the "time-constant" of the instrumented components, and (2) imposing the maximum heating conditions on the missile which were attainable with available aircraft for captive and firing tests.

During the early part of the test program, it became apparent that the F-104 aircraft used in these tests did not have sufficient performance or fuel to give a satisfactory sustained temperature step input to the missile. However, stagnation temperature rates of about $80^{\circ}\text{F}/\text{min}$ were experienced in the routine course of the maximum performance tests.

After the first preliminary flights, it was determined that maximum heating was obtained by climbing to about 35,000 ft, accelerating to about Mach 1.8, climbing at an essentially constant Mach number to 50,000 to 55,000 ft, and then again accelerating in level flight to about Mach 2.0. The F-104 is inlet-temperature limited at 100°C and, therefore, the exact top Mach number varied from day to day with the static temperature. Furthermore, this temperature limit made it difficult for the pilot to predetermine a Mach number over which he should not go.

These factors, plus the added variable of having several pilots throughout the flight test program, yielded flights with individualistic stagnation profiles.

Good temperature data were received on six captive flights and the firing flight. Time correlation between aircraft and telemetered data was not obtained on one flight, so that the data from this flight are of doubtful value.

DATA

The stagnation temperature, T_s , is computed as

$$T_s = T_\infty (1 + 0.2M^2) \quad (1)$$

where T_∞ is static temperature at the given altitude (from meteorological data) and M is the Mach number. Somewhat peculiar looking stagnation temperature profiles were obtained in these tests due to the rapid change in static temperature during the climb to altitude and the M^2 relationship.

The stagnation temperature is not to be construed as the forcing temperature upon the various channels of data, but rather is an indication of the maximum temperature to be expected at the stagnation point of the missile. The forcing temperature or recovery temperature is, however, a function of the stagnation temperature.

The stagnation temperature data plotted for the free-flight portion of Flight 7 was computed from trajectory data obtained from ground instrumentation.

No data was obtained on Channel 14 for Flights 2-5 because of a damaged thermocouple lead. Channel 6 exhibited some peculiar characteristics on Flights 3, 6, and 7 which have not yet been reconciled. Representative temperature data obtained are presented in Fig. 8 and 9.

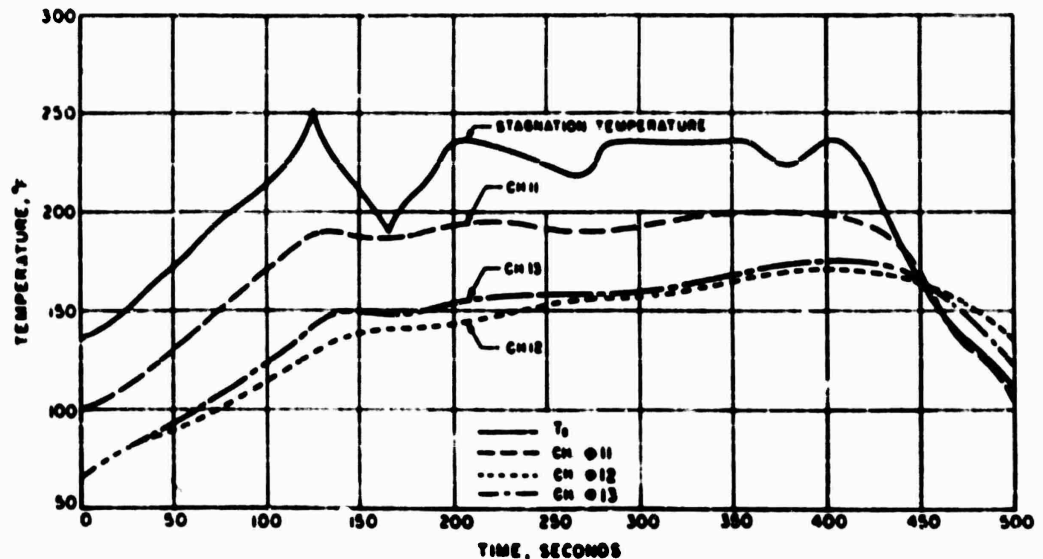

FIG. 8. Typical Temperature Data for Captive Flight.

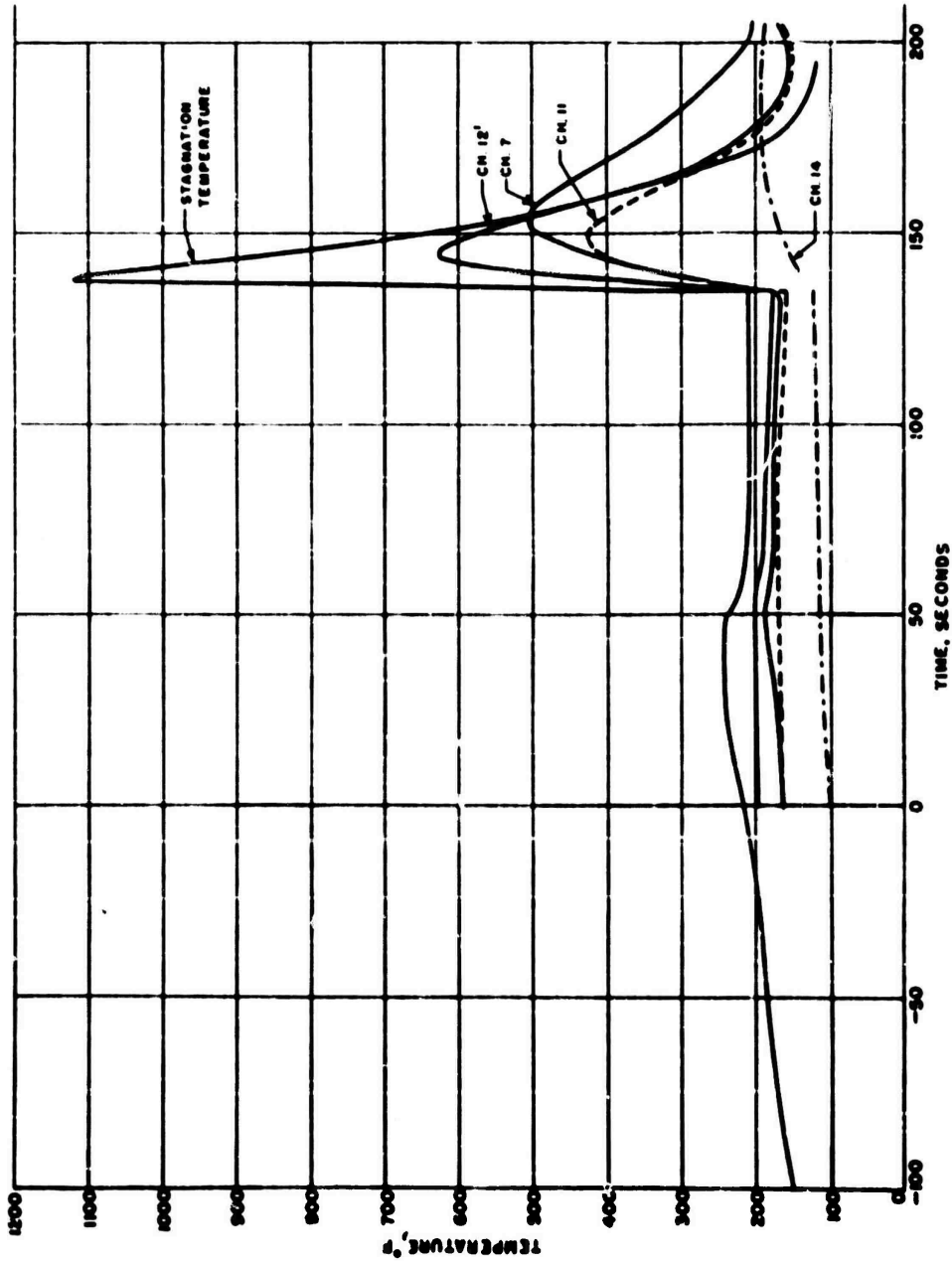

FIG. 9. Typical Temperature Data from Air Firing.

As a result of greater reading error in the less-sensitive telemetered data, more data scatter was obtained on the flight in which the missile was fired.

ANALYSIS

A thorough analysis of the data is planned. Minor refinements may be made in the data reduction and particular attention will be given to the actual trajectory followed by the fired round. Askania data smoothing techniques are being examined to determine the best estimate of the actual trajectory. This trajectory information will then be used as the input to analytical methods for predicting the temperatures expected under the test conditions. These results will be compared with the values obtained experimentally.

These data, to be published in a separate report, are expected to be very useful in corroborating schemes to predict temperatures arising from aerodynamic heating at conditions beyond the present test capabilities.

SECTION III. THERMAL LAG OF INSULATED THERMOCOUPLE REFERENCE JUNCTION BLOCK

By

Warren K. Smith

INTRODUCTION

In measuring temperatures at various locations on missiles during flight tests, thermocouples are one of the more desirable means of sensing the temperatures because they can be made with small thermal capacity and fast response. They also generate their own electrical output for measuring and recording instruments. However, thermocouples require that reference junctions at known temperatures be provided, and this requirement presents some problems.

BACKGROUND

A considerable period of time may elapse between assembly of the missile and its firing from the aircraft. An ice water reference would, therefore, not be practical. A heated and controlled reference block would call for connection to the aircraft power supply and require some time to become stable. The approach used here is to provide a well-insulated metal block into which the cold junctions are all embedded and electrically insulated from each other. One junction in the block can be temporarily connected with an external junction in an ice bath (thermos bottle) and to a portable potentiometer. By this means the actual temperature of the reference junction block can be measured just prior to take-off of the aircraft. By knowing the environment surrounding the reference block during flight, the flight time, and the insulating properties of the thermal protection around the block, the reference block temperature can be known within the general limits of accuracy expected for this test.

RESULTS OF TEST

A brief test was made to obtain some idea of the rapidity of temperature change that may occur in the block. The steel block was 2 inches in diameter by 2 inches long with twenty-five 1/16-inch diameter holes drilled in one end to the middle of the block. The block was contained in a wooden box with inside dimensions 4 x 4 x 4 inches, with the intervening space being occupied by styrafoam. The box containing the styrafoam and steel block was first equalized at room temperature and then placed in an oven at 220°F, after which temperature was measured on a portable potentiometer every 5 minutes.

The block temperature during this test is plotted in Fig. 10 along with the oven temperature. The oven temperature dropped about 30°F when the box was inserted. Twenty minutes passed before any temperature rise in the block could be detected. Then the rate of rise was only about 2°F in 5 minutes.

It is considered likely that, in most applications, the missile will be fired before the reference block can change more than 4°F from the final pre-takeoff reading. This accuracy should be sufficient to preclude the trouble and expense of other arrangements.

If the time between take-off and missile firing is likely to exceed 30 minutes by any significant amount, a thermistor can be used to monitor the block temperature. Of course, this will require a channel and means of telemetering the reference block temperature.

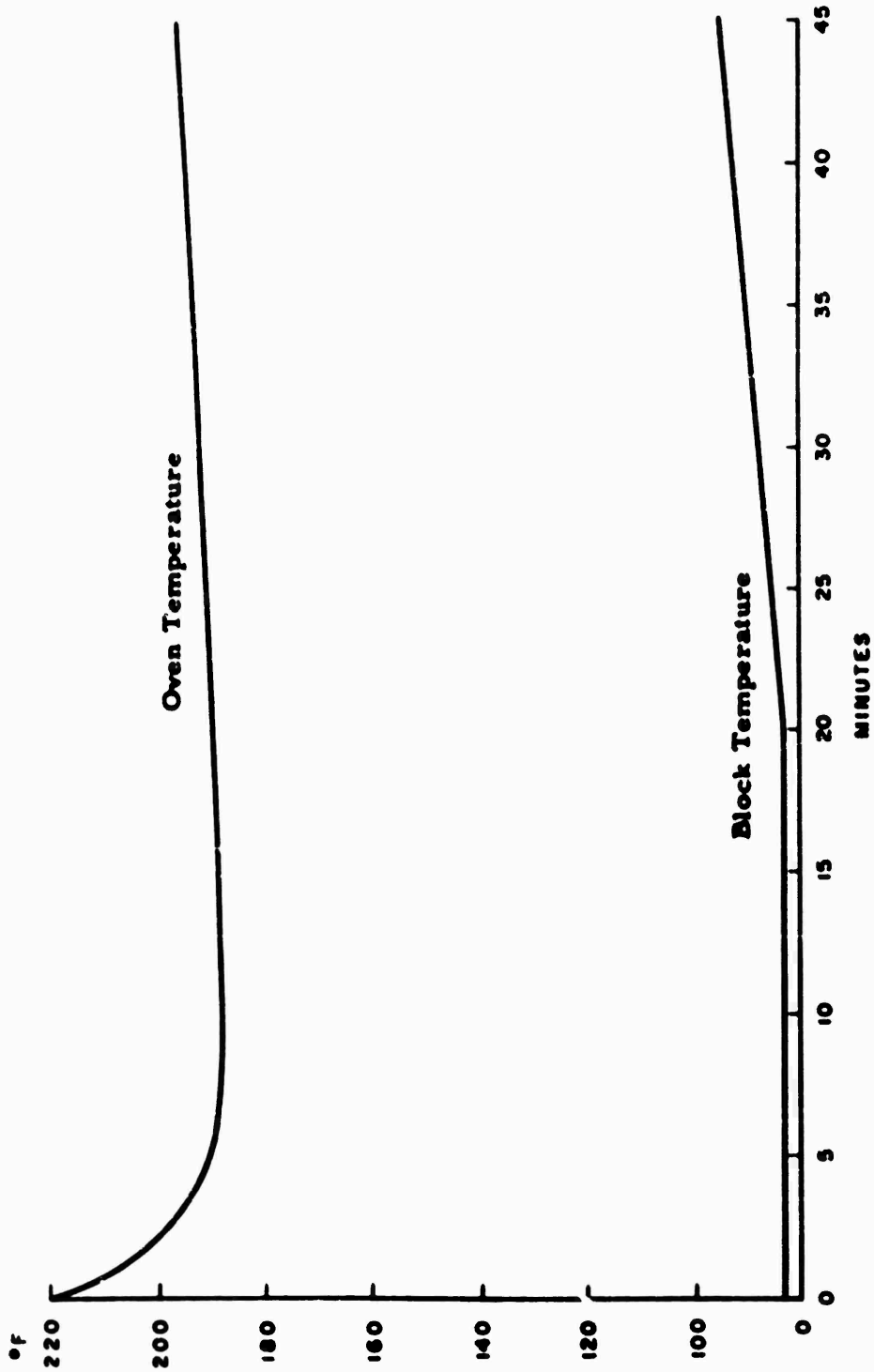

FIG. 10. Thermal Lag of Insulated Thermocouple Reference Junction Block (Block Temperature Rise $\approx 0.0053^{\circ}\text{F}/\text{Min}/^{\circ}\Delta\text{F}$ after 20 Min).

SECTION IV. RADIANT HEATING TESTS OF A NOSE CONE

By

Warren K. Smith

PRELIMINARY TEST

A test of a nose cone was conducted in the radiant heating facility to determine how well this facility could simulate a desired environment and to test some ideas concerning a light-weight nose cone.

Two temperature control points were used to program the heaters. One location was the stagnation point, and the other was about half way along the outer surface of the cone. The stagnation-point thermocouple controlled a flat bank of quartz tube IR heaters behind which was a set of three concentric reflectors (see Fig. 11) designed to provide the proper heat flux distribution over the nose cone. The thermocouple on the cone controlled a cylindrical bank of tubes. A total of 150 kw was available in the three channels used.

The EMF from the control thermocouples was compared with EMF programmed according to a predetermined temperature schedule. The differential or error signal was amplified and used to control the ignition circuit to the heater tubes. The location of the thermocouples is shown in Fig. 12.

Figure 13 is a comparison between the temperatures desired for the stagnation point and those measured in this test. The first peak was not followed due to insufficient gain setting on the heat control units. This was corrected during the test, and the second peak was approached better, although still not too closely. However, the inside steel shell was reasonably close to the temperature predicted for this program.

Figure 14 presents the results of temperature measurements on the cone. Again, the first temperature peak was not followed, but the second one was. Inside shell temperatures were about as expected.

Figure 15 shows that the payload supporting structure did not reach dangerous temperatures, but the payload container itself did get too hot. It was observed that all of the spacemetal supporting structure and the numerous spotwelds were undamaged.

The phenolic-asbestos outer surface suffered some checking and local peeling of layers (see Fig. 16) and extensive charring, but did not separate from the steel inner shell. Two gas blisters formed between the plastic and steel hemisphere and caused two inward dents in the steel shell.



FIG. 11. Test Set-Up, Showing Special Concentric Reflectors.

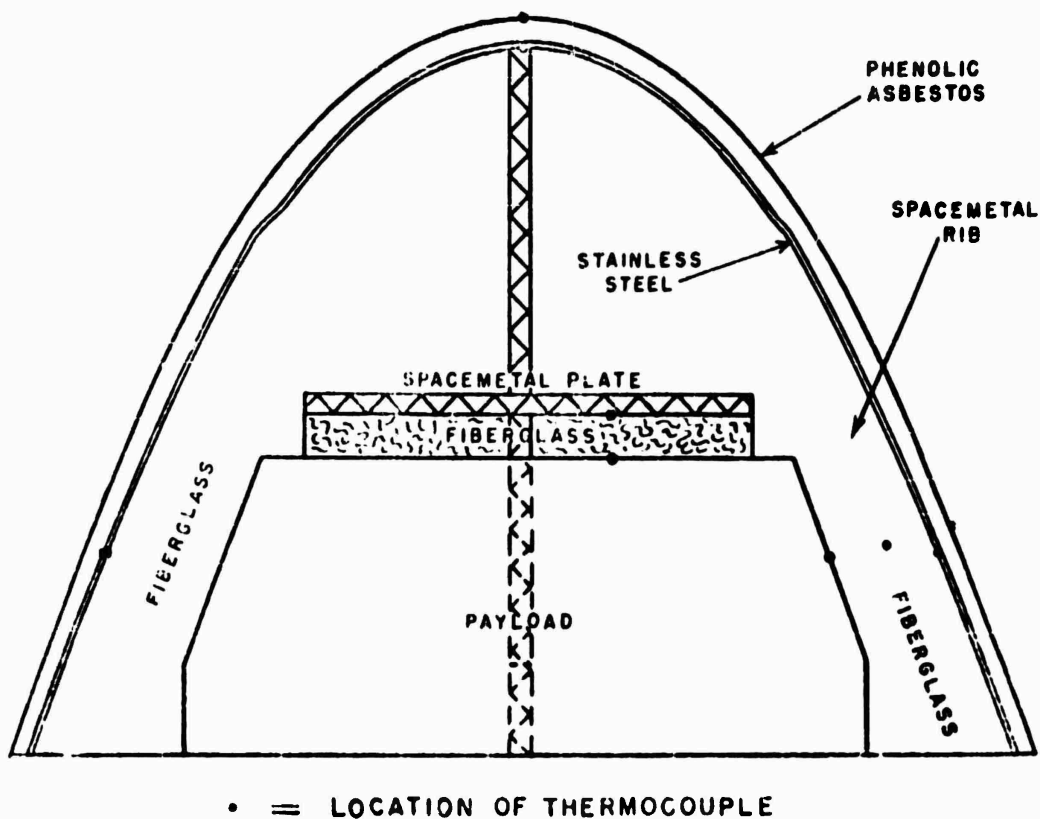

FIG. 12. Arrangement of Nose Cone Structure and Thermocouple.

In conclusion, it can be said that the facility was not completely successful in providing the desired environment. Simulation was close enough to indicate that reasonably accurate simulation can be obtained by this means. More work with the system is necessary before this can be attained, however.

In addition, it was apparent that, with some small modification, a nose cone of the type tested would probably withstand an environment similar to the one prescribed here.

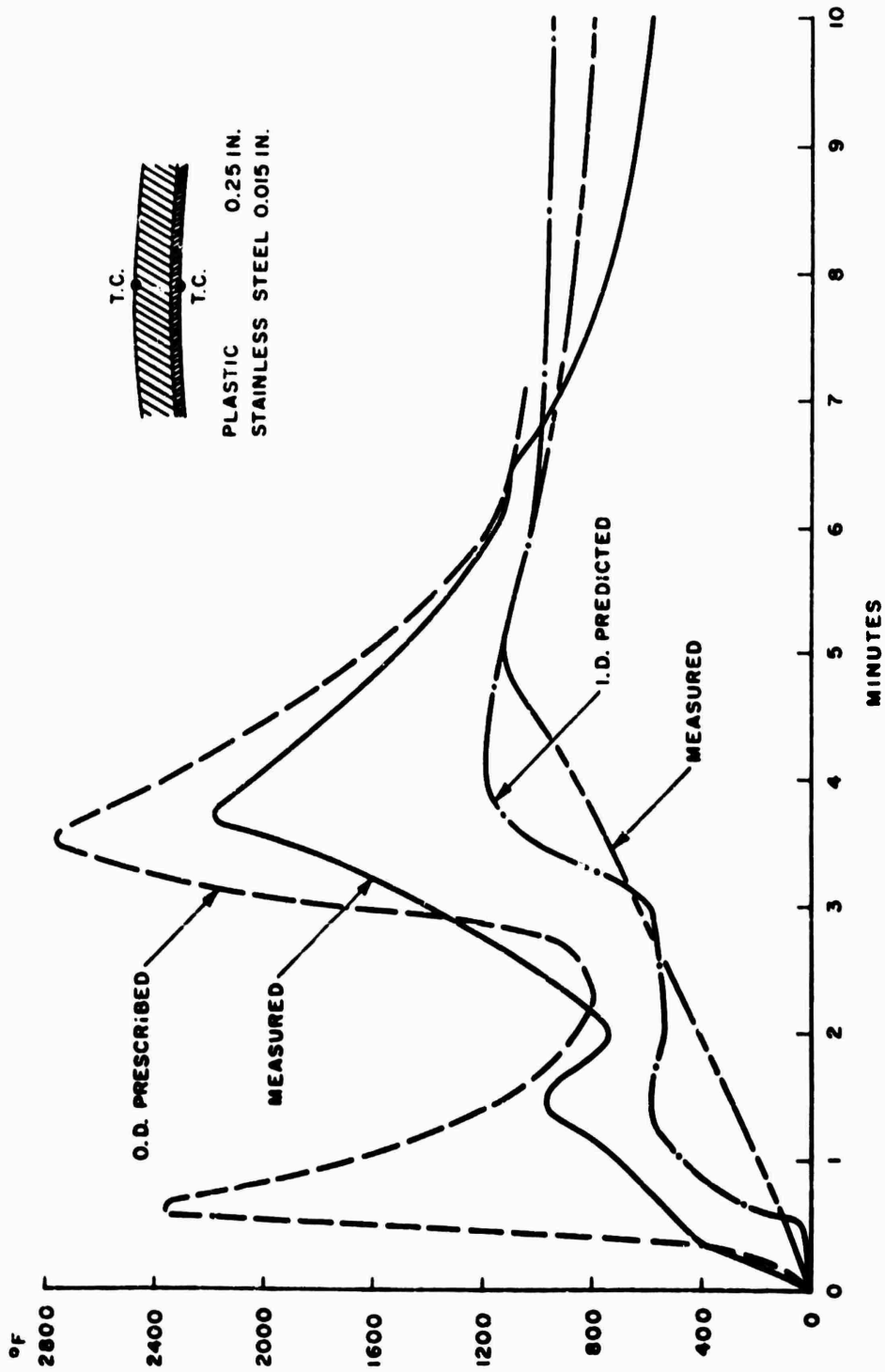

FIG. 13. Temperatures at Stagnation Point (Station No. 1).

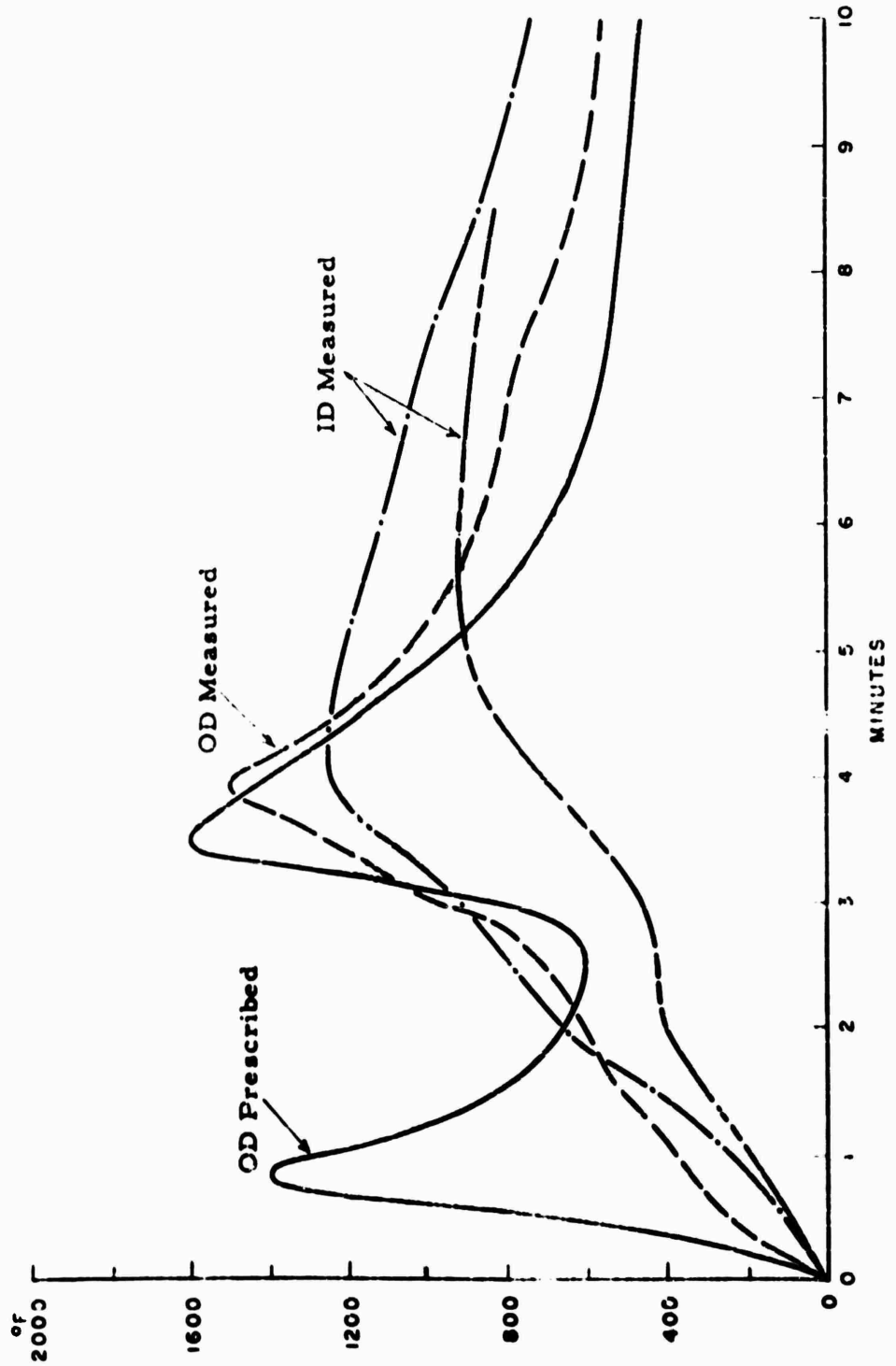

FIG. 14. Temperatures on Side of Cone (Station No. 3):
1/16-Inch Plastic (Outside), 0.015-Inch Stainless Steel.

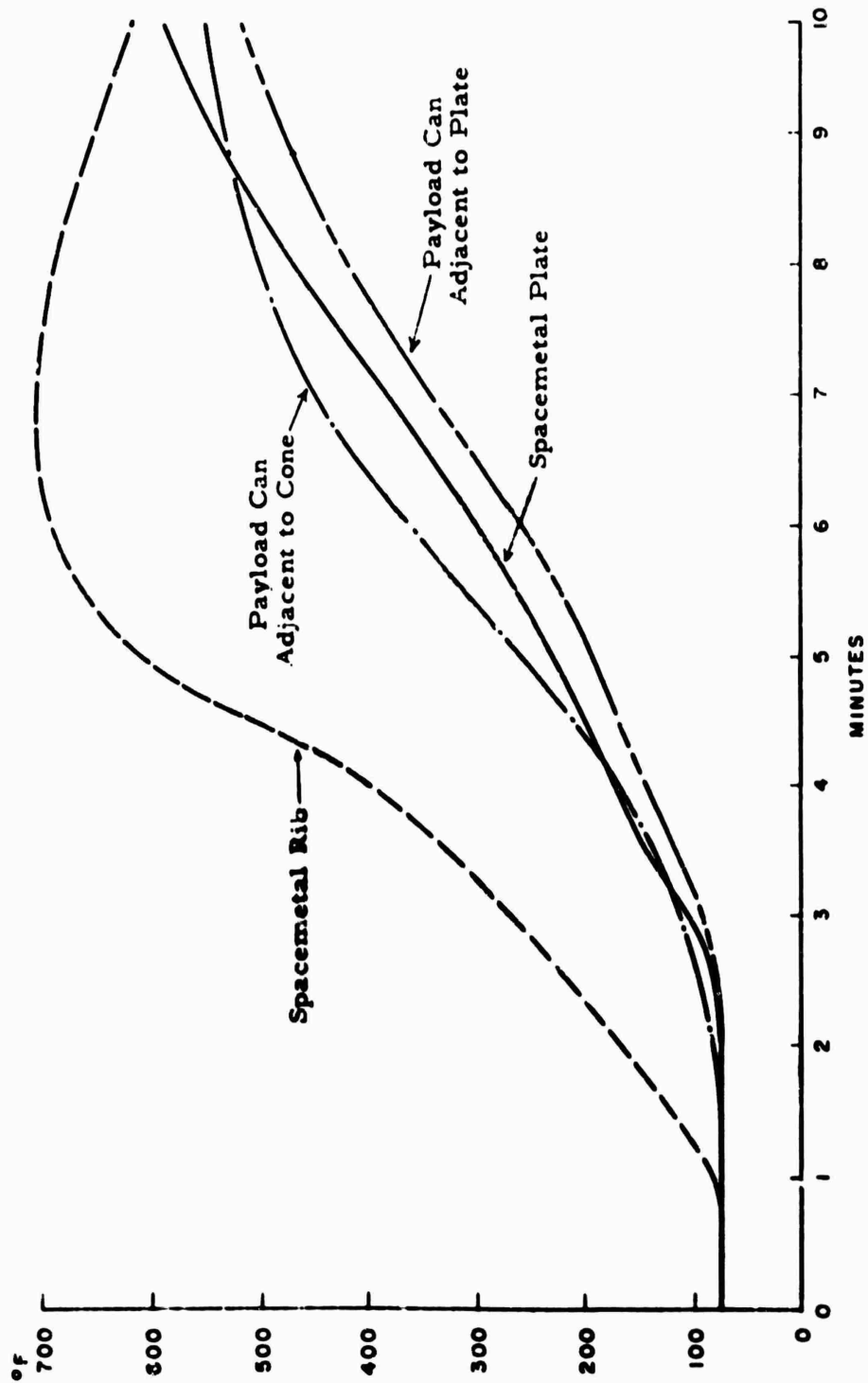

FIG. 15. Temperatures of Payload Container and Supports.

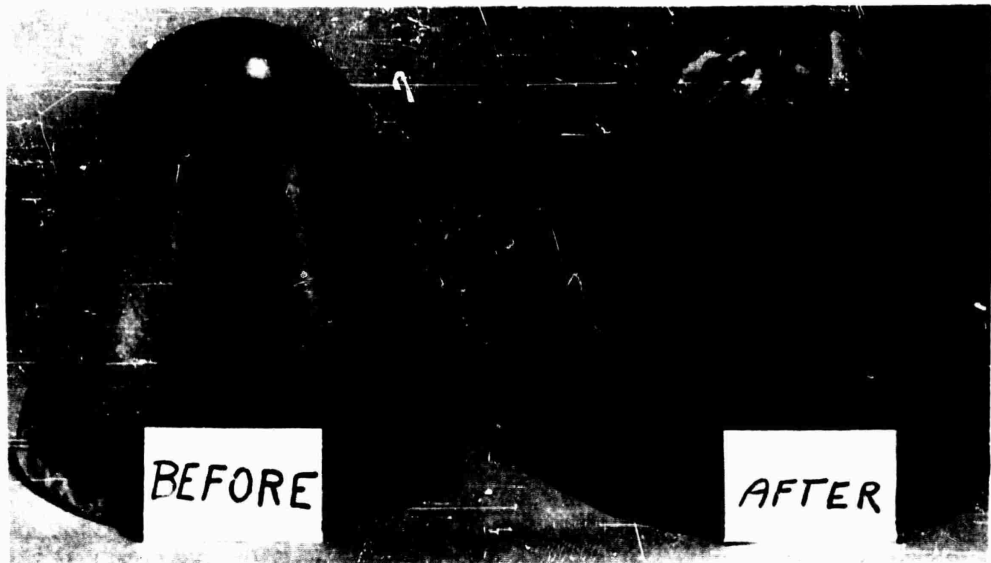

FIG. 15. Nose Cone, Before and After Test.

SECOND TEST, MODIFIED NOSE CONE

A second radiant heating test was conducted on a modified light-weight nose cone. In this test, alterations were made on the basis of the results of the first test. The principal modifications were an increase in payload insulation and the provision of small gas-relief holes drilled through the inner steel shell into the plastic. Care was used in the program adjustment so that both peak temperatures would be approached. The main objectives of the test were (1) to attempt to obtain more accurate simulation of the environment desired, and (2) to assure adequate protection of the payload, that no structural failure would occur, and that the plastic covering would survive the heating cycles without coming off the steel shell.

Figure 17 is a sketch of the nose cone showing the location of the Chromel-Alumel thermocouples. Number 1 and 7 were used for controls as well as recording. Thermocouple No. 1 controlled the flat bank of radiant heating tubes arranged as in the first test to simulate the heating at the stagnation point. Number 7 controlled the 60 lamps in the surrounding cylindrical arrangement. Altogether, 150 kw of power was available in the three channels. The thermocouples at the surface of the plastic were cemented in shallow grooves with Sauereisen cement.

Curves comparing the recorded temperatures at the various locations with the corresponding programmed temperatures are presented

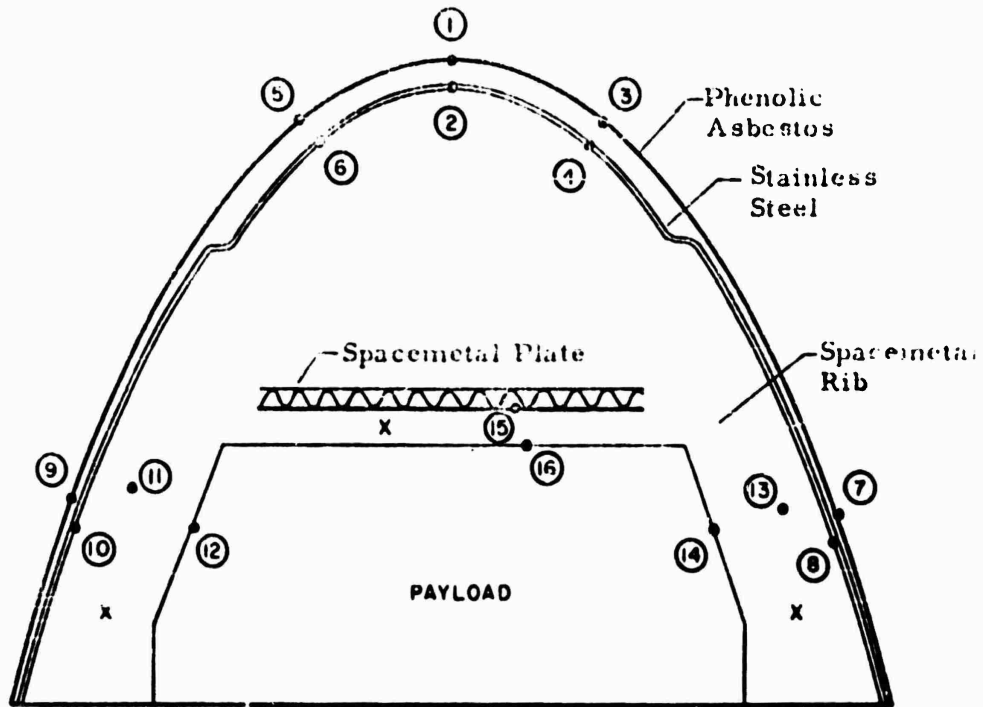

● : LOCATION OF THERMOCOUPLES

1/4" MICROQUARTZ

1 LAYER STAINLESS STEEL FOIL

2 LAYERS GLASS CLOTH

1/2" FIBERGLASS BATT

X : INSULATION

FIG. 17. Arrangement of Nose Cone Structure and Thermocouples.

in Fig. 18-21. Figure 18 indicates that the programmed peak temperatures were not quite achieved, but a maximum surface temperature of about 2400°F was attained briefly. Inside temperatures were not far out of line, indicating that, for one thing, the thermal property data for the material may be fairly accurate. At the 45-deg location on the hemisphere, the measured temperatures were consistently below those programmed. This was because of inadequate redistribution of the radiant energy by the special concentric reflectors built for this purpose.

Calculations for the side of the cone (Fig. 20) were made only for a thin metal shell, whereas in the test model 1/16 inch of plastic was molded over the exterior of the cone. Except for the first peak, the outside surface temperature of the plastic followed that predicted for the sheet metal rather well. Figure 21 shows that the spacemetal disc and

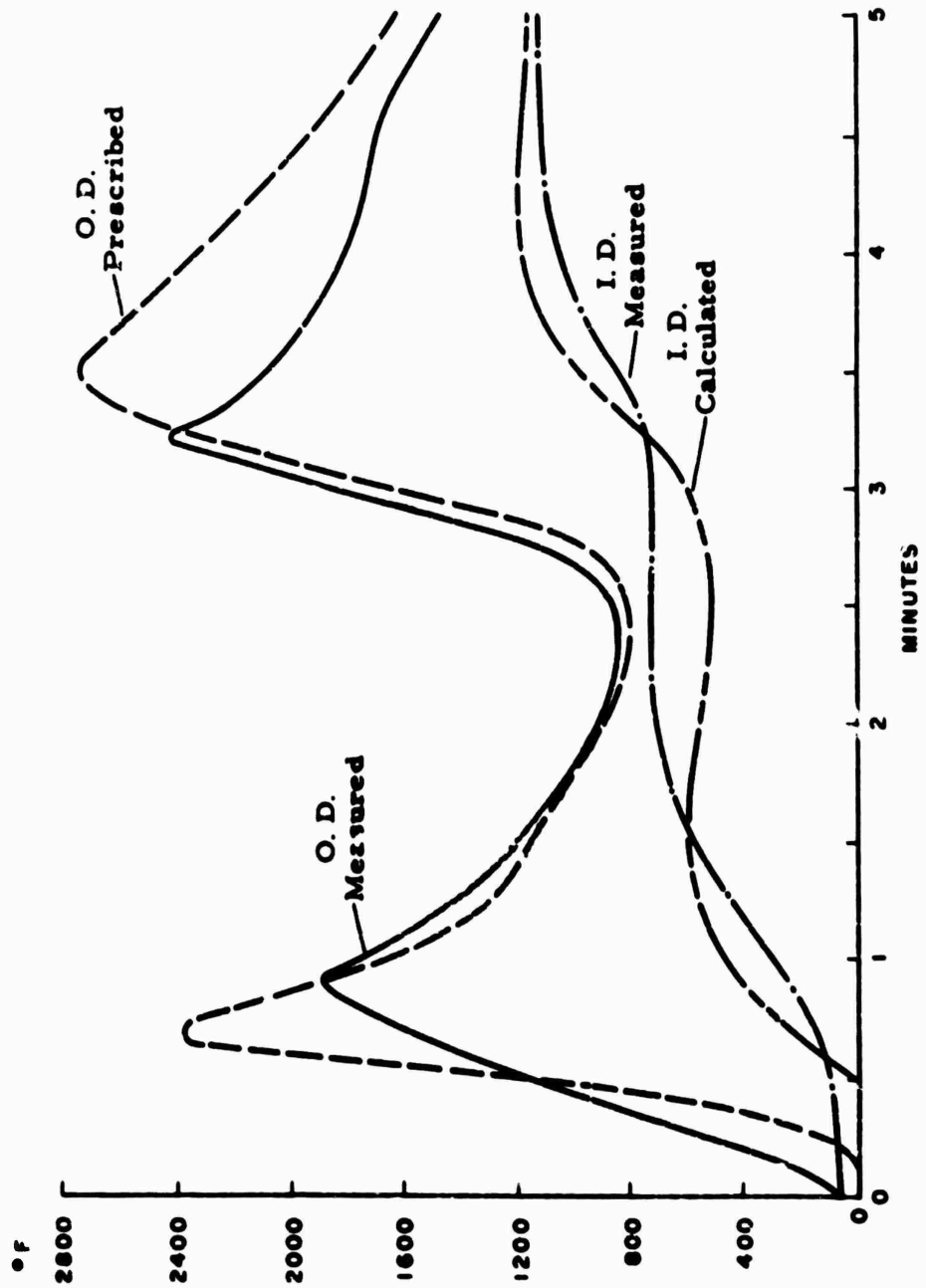

FIG. 18. Stagnation Point on Nose Cone (1/4-Inch Plastic Over 0.015-Inch Stainless Steel).

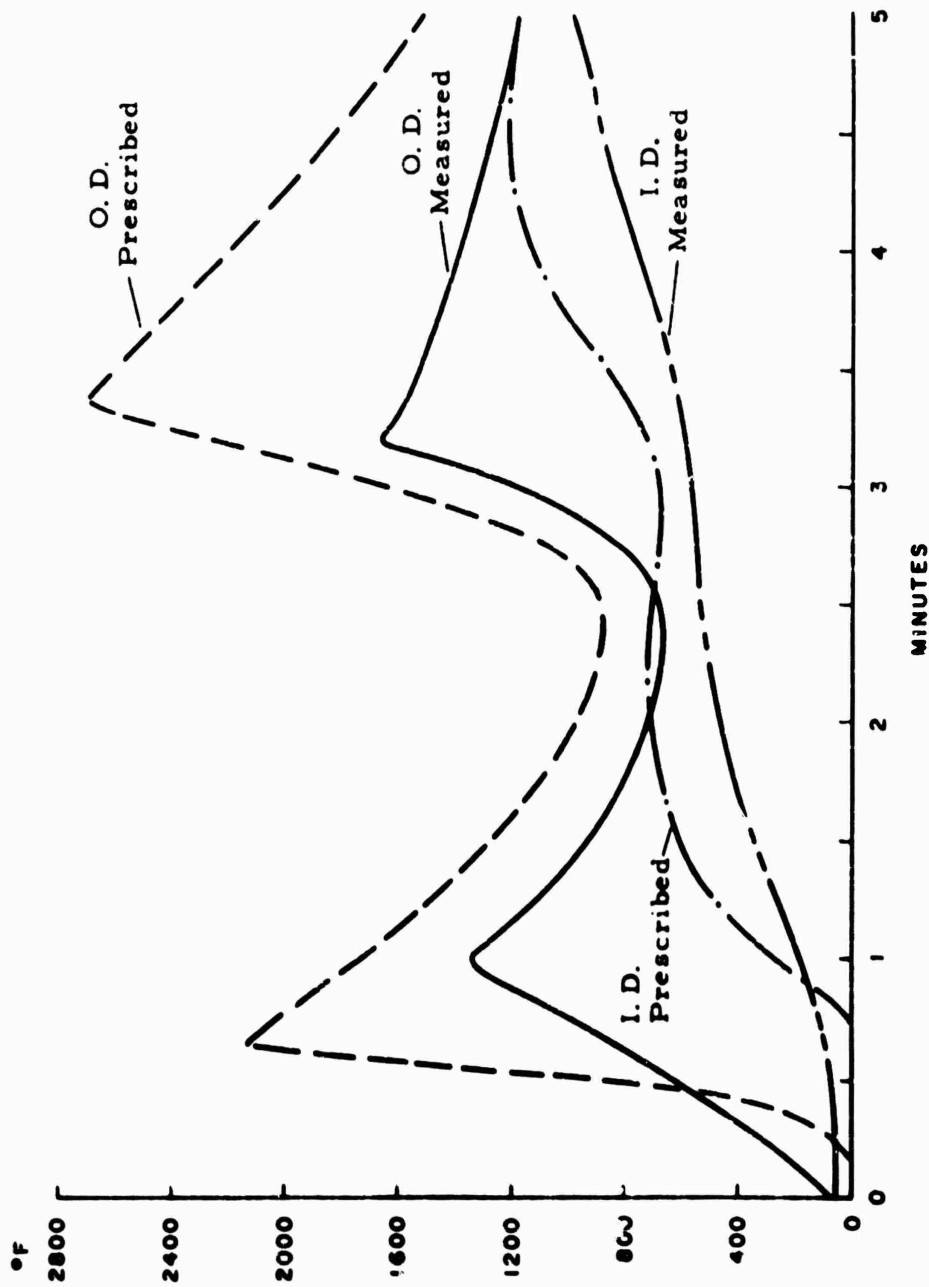

FIG. 19. 45-Deg From Stagnation Point on Hemisphere (1/4-Inch Plastic Over 0.015-Inch Stainless Steel).

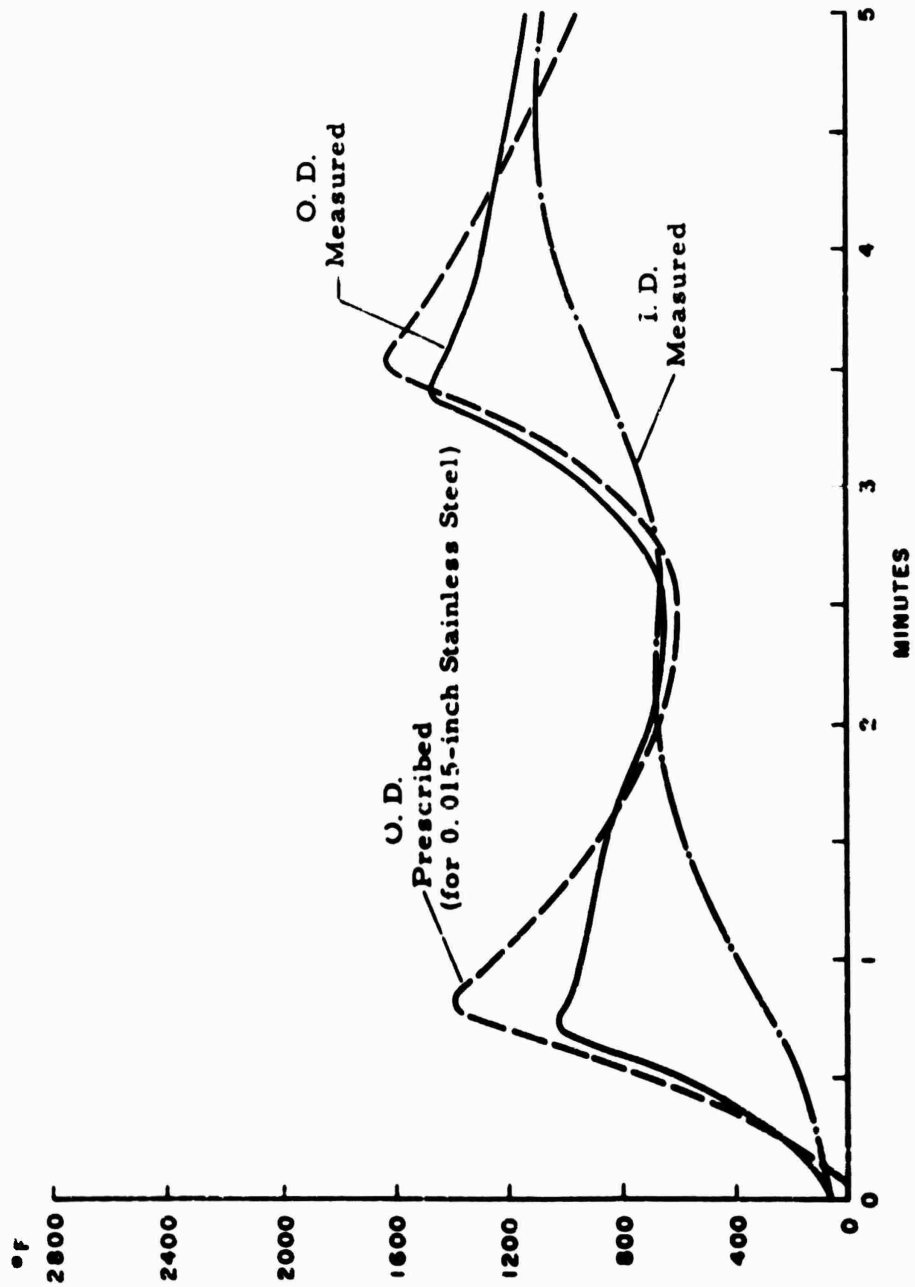

FIG. 20. Side of Cone 8 Inches Aft (1/16-Inch Plastic Over 0.015-Inch Stainless Steel).

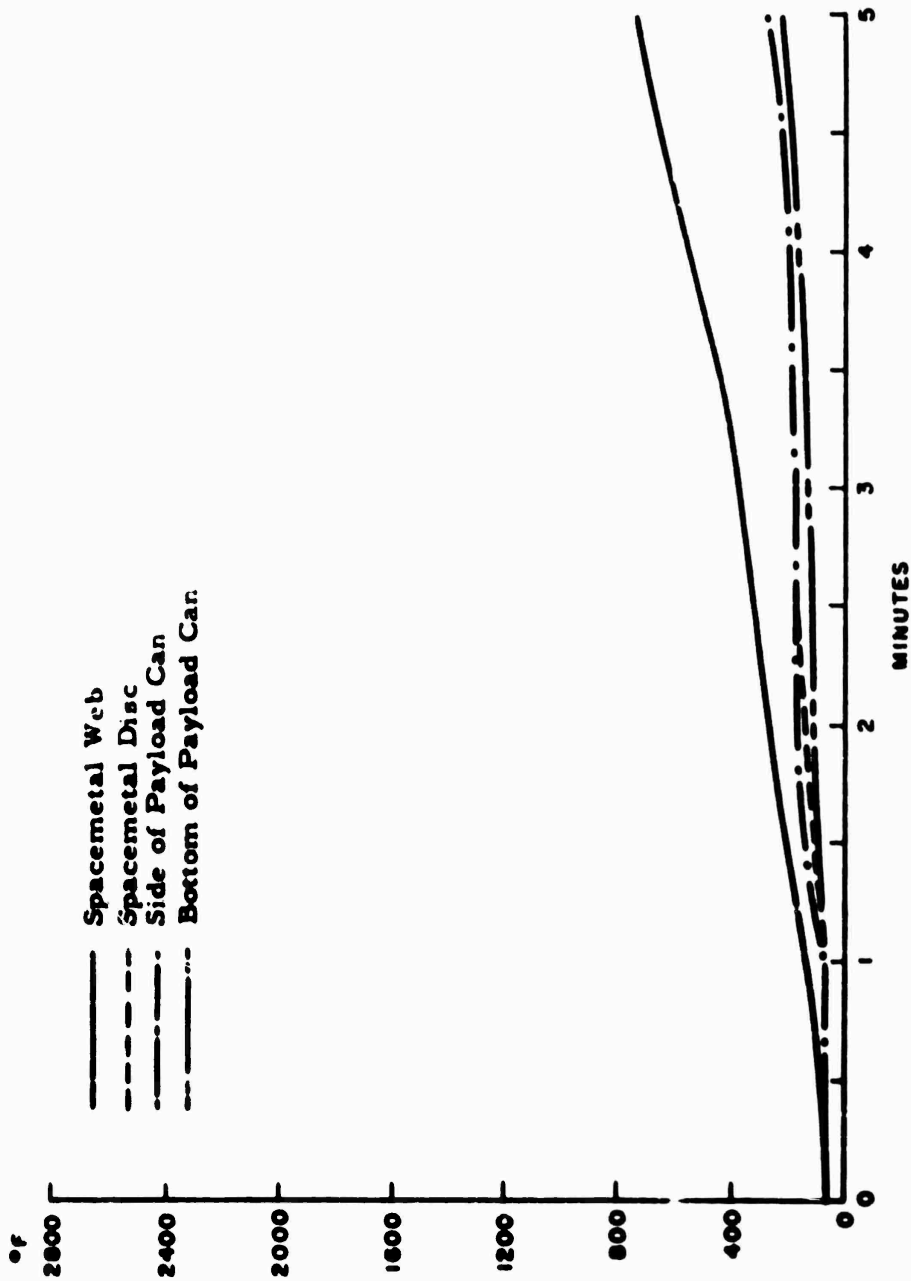

FIG. 21. Payload Can and Supporting Structure.

payload can did not exceed 200-250°F within 5 minutes. Since the can wall is paper-thin and no filling was present in the can for a heat sink, it is felt that any payload would be adequately protected.

No appreciable peeling or delamination occurred in the nose cone during the test, but some checking was present on the surface. The surface was well charred. The cemented-in thermocouples were undisturbed. Figure 22 shows a section through the nose cone obtained by slicing the whole assembly in two with a bandsaw. The structural supports and insulation are revealed. In one place a bubble occurred that separated the plastic from the steel shell. Vibration from the bandsaw caused the separation that is lower along the sides. The cap and shell still appeared to be quite rigid and strong, even though deeply charred.

The "salt and pepper" holes, drilled into the steel and plastic from the inside to relieve gas pressure and prevent delamination, should have been drilled from the outside. As it was, gases from the decomposing plastic condensed and left considerable phenol inside the nose cone.

In conclusion, the simulation of a predetermined environment by the radiant heating facility, although better than it was in the first test, is still not completely satisfactory. The major problem appears to be in the design of proper reflectors and in the arrangement of tubes in a manner which will adequately simulate a given heat flux gradient over the surface of the test item. The facility appears to be capable of quite accurate simulation of a heat flux which varies with time only and not with position on the test surface.

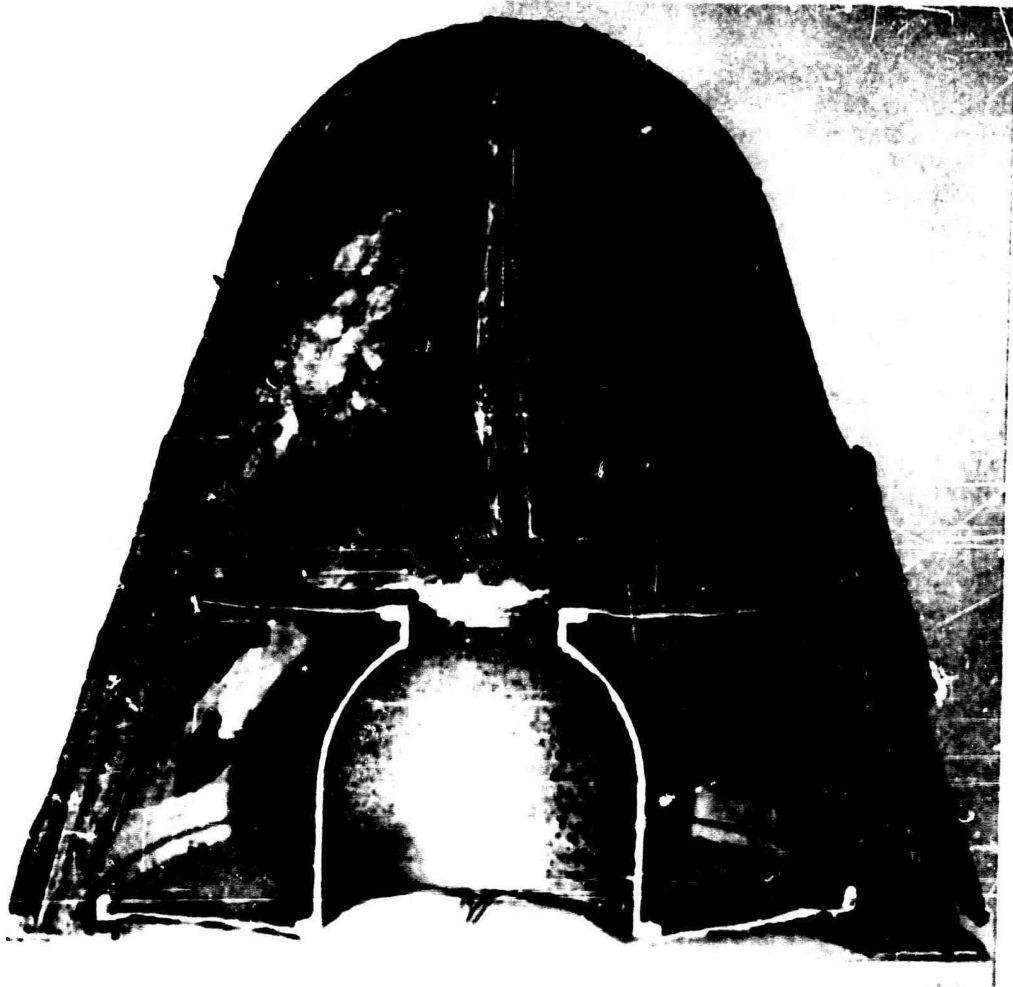

FIG. 22. Nose Cone, Sectioned After Test.

ABSTRACT CARD

U. S. Naval Ordnance Test Station
Notes on Experimental Techniques in Aerodynamic Heating Problems (U), by L. R. Argabright, C. H. Johnson, and Warren K. Smith. China Lake, Calif., NOTS, 28 April 1961. 44 pp. (NAVWEPS Report 7652, NOTS TP 2676). CONFIDENTIAL.

ABSTRACT. This report contains a series of notes on experimental techniques used in applied research on aerodynamic heating problems. Tests in a radiant heating facility, construction and use of a

Card UNCLASSIFIED ○ (Over)
1 card, 4 copies

U. S. Naval Ordnance Test Station
Notes on Experimental Techniques in Aerodynamic Heating Problems (U), by L. R. Argabright, C. H. Johnson, and Warren K. Smith. China Lake, Calif., NOTS, 28 April 1961. 44 pp. (NAVWEPS Report 7652, NOTS TP 2676). CONFIDENTIAL.

ABSTRACT. This report contains a series of notes on experimental techniques used in applied research on aerodynamic heating problems. Tests in a radiant heating facility, construction and use of a

Card UNCLASSIFIED ○ (Over)
1 card, 4 copies

U. S. Naval Ordnance Test Station
Notes on Experimental Techniques in Aerodynamic Heating Problems (U), by L. R. Argabright, C. H. Johnson, and Warren K. Smith. China Lake, Calif., NOTS, 28 April 1961. 44 pp. (NAVWEPS Report 7652, NOTS TP 2676). CONFIDENTIAL.

ABSTRACT. This report contains a series of notes on experimental techniques used in applied research on aerodynamic heating problems. Tests in a radiant heating facility, construction and use of a

Card UNCLASSIFIED ○ (Over)
1 card, 4 copies

U. S. Naval Ordnance Test Station
Notes on Experimental Techniques in Aerodynamic Heating Problems (U), by L. R. Argabright, C. H. Johnson, and Warren K. Smith. China Lake, Calif., NOTS, 28 April 1961. 44 pp. (NAVWEPS Report 7652, NOTS TP 2676). CONFIDENTIAL.

ABSTRACT. This report contains a series of notes on experimental techniques used in applied research on aerodynamic heating problems. Tests in a radiant heating facility, construction and use of a

Card UNCLASSIFIED ○ (Over)
1 card, 4 copies

NAVWEPs Report 7652

free-flight test vehicle, and a simple thermocouple reference junction are described.

NAVWEPs Report 7652

free-flight test vehicle, and a simple thermocouple reference junction are described.

NAVWEPs Report 7652

free-flight test vehicle, and a simple thermocouple reference junction are described.

NAVWEPs Report 7652

free-flight test vehicle, and a simple thermocouple reference junction are described.

INITIAL DISTRIBUTION

- 8 Chief, Bureau of Naval Weapons
 - R-12 (1)
 - RM (3)
 - RM-3 (1)
 - RMGA-41 (1)
 - RMMO-4 (1)
 - RT-1 (J. D. Nicolaides) (1)
- 6 Chief of Naval Operations
 - Deputy Chief for Air (1)
 - Operations Evaluation Group (2)
- 1 Naval Avionics Facility, Indianapolis (Library)
- 3 Naval Ordnance Laboratory, White Oak
 - Associate Director for Aeroballistics (1)
 - Chief, Aerodynamics Department (1)
 - Chief, Ballistics Department (1)
- 2 Naval Propellant Plant, Indian Head
- 2 Naval Underwater Ordnance Station, Newport
- 2 Naval Weapons Laboratory, Dahlgren (Technical Library)
- 3 Naval Weapons Plant
 - Code 752 (2)
 - Code 755 (1)
- 3 Chief of Ordnance
 - ORDTB (1)
 - ORDTM (1)
 - ORDTS (1)
- 4 Aberdeen Proving Ground
 - Ballistic Research Laboratories
 - Chief, Free-Flight Aerodynamics Branch (1)
 - Chief, Exterior Ballistics Laboratory (1)
 - Technical Information Branch (1)
 - Development and Proof Services (1)
- 1 Army Rocket & Guided Missile Agency, Redstone Arsenal (C)
- 2 Frankford Arsenal
 - Library (1)
 - Pitman-Dunn Laboratory (1)
- 1 Picatinny Arsenal (Technical Division)
- 1 Rock Island Arsenal
- 1 Air Force Cambridge Research Laboratories, Laurence G.
- 2 Air Proving Ground Center, Eglin Air Force Base
- 1 Air University Library, Maxwell Air Force Base
- 1 Tactical Air Command, Langley Air Force Base (TPL-RQD)
- 1 Weapons Systems Evaluation Group
- 3 Ames Research Center
 - Library (2)
 - Chief, High Speed Research Division (1)
- 1 Langley Research Center (Library)
- 1 Lewis Research Center
- 2 Applied Physics Laboratory, JHU, Silver Spring
- 1 Armour Research Foundation, Chicago (G. A. Nothmann)
- 2 Franklin Institute, Philadelphia
 - Library (1)
 - E. E. Hannum (1)
- 1 Jet Propulsion Laboratory, CIT, Pasadena (Dr. W. H. Pick)
- 1 The Rand Corporation, Santa Monica, Calif.
- 1 University of Chicago, Institute for Air Weapons Research (