

UNCLASSIFIED

AD NUMBER

AD325843

CLASSIFICATION CHANGES

TO: unclassified

FROM: restricted

LIMITATION CHANGES

TO:  
Approved for public release; distribution is unlimited.

FROM:  
Controlling Organization: British Embassy, 3100 Massachusetts Avenue, NW, Washington, DC 20008.

AUTHORITY

DSTL, AVIA 6/23857, 11 Dec 2008; DSTL, AVIA 6/23857, 11 Dec 2008

THIS PAGE IS UNCLASSIFIED

AD 325843

Decl OADR

PA

EXCLUDED FROM AUTOMATIC  
REGRADING; Dod DIR 5200.10  
DOES NOT APPLY

OTIA  
14899

**ROYAL AIRCRAFT ESTABLISHMENT**  
(ABERPORTH)

TECHNICAL NOTE No: TD. 58

**A METHOD OF MEASURING  
SCALAR MISS DISTANCE USING A  
C.W. OSCILLATOR IN THE MISSILE**

by

T. C. GRIFFITHS, B.Sc.

89834

EXCLUDED FROM AUTOMATIC REGRADING  
DOD DIR 5200.10 DOES NOT APPLY

PICATINNY ARSENAL  
TECHNICAL INFORMATION SECTION

MARCH, 1961

1. THIS INFORMATION IS DISCLOSED ONLY FOR OFFICIAL USE BY THE RECIPIENT GOVERNMENT AND SUCH OF ITS CONTRACTORS, UNDER SEAL OF SECRECY, AS MAY BE ENGAGED ON A DEFENCE PROJECT. DISCLOSURE TO ANY OTHER GOVERNMENT OR RELEASE TO THE PRESS OR IN ANY OTHER WAY WOULD BE A BREACH OF THESE CONDITIONS.

2. THE INFORMATION SHOULD BE SAFEGUARDED UNDER RULES DESIGNED TO GIVE THE SAME STANDARD OF SECURITY AS THAT MAINTAINED BY HER MAJESTY'S GOVERNMENT IN THE UNITED KINGDOM.

3. THE RECIPIENT IS WARNED THAT INFORMATION CONTAINED IN THIS DOCUMENT MAY BE SUBJECT TO PRIVATELY OWNED RIGHTS.

MINISTRY OF AVIATION

THIS DOCUMENT IS THE PROPERTY OF H.M. GOVERNMENT AND ATTENTION IS CALLED TO THE PENALTIES ATTACHING TO ANY INFRINGEMENT OF THE OFFICIAL SECRETS ACTS, 1911-1939

It is intended for the use of the recipient only, and for communication to such officers under him as may require to be acquainted with its contents in the course of their duties. The officers exercising this power of communication are responsible that such information is imparted with due caution and reserve. Any person other than the authorised holder, upon obtaining possession of this document, by finding or otherwise, should forward it, together with his name and address, in a closed envelope to:-

THE SECRETARY, MINISTRY OF AVIATION, LONDON, W.C.2

Letter postage need not be prepaid, other postage will be refunded. All persons are hereby warned that the unauthorised retention or destruction of this document is an offence against the Official Secrets Acts.

20080730 198

(1)  
89834

RESTRICTED

U.D.C. No. 629.192.2.079.3 : 621.373

3  
Technical Note No. TD.58

4  
March, 1961

2 ROYAL AIRCRAFT ESTABLISHMENT, DB

(ABERPORTH)

4  
A METHOD OF MEASURING SCALAR MISS DISTANCE  
USING A C.W. OSCILLATOR IN THE MISSILE

by

5  
T.C. Griffiths, B.Sc.  

---

SUMMARY

A method is described of measuring the soalar miss distance of a missile from a target by recording a beat frequency which appears on the signal from a CW oscillator which is already carried in the missile for tracking purposes. The method is intended for use in trials of missiles against parachute targets, but it has been shown to work in the case of aircraft targets also.

---

RESTRICTED

LIST OF CONTENTS

	<u>Page</u>
1 INTRODUCTION	4
2 THEORETICAL DISCUSSION	4
2.1 The M.T.S. system	4
2.2 Doppler frequency shift of the M.T.S. signal received directly from the missile	4
2.3 Doppler frequency shift of the M.T.S. signal received by reflection from the target	5
2.3.1 Stationary target	5
2.3.2 Moving target	6
2.4 Beat frequency	7
2.5 Range of operation	7
3 EXPERIMENTAL TECHNIQUE	8
3.1 Recording the beat frequency	8
3.2 Analysis of the record	8
3.3 Calculation of miss distance	9
4 RESULTS	10
4.1 Aircraft targets	10
4.2 Parachute targets	10
5 COMMENTS ON RESULTS	11
6 CONCLUSIONS	12
7 RECOMMENDATIONS FOR FURTHER WORK	12
8 ACKNOWLEDGEMENTS	12
LIST OF SYMBOLS	12
LIST OF REFERENCES	13
ADVANCE DISTRIBUTION LIST	13
APPENDIX - Reflection from a convex surface	14
ILLUSTRATIONS - Figs.1-11	-
DETACHABLE ABSTRACT CARDS	-

LIST OF ILLUSTRATIONS

	<u>Fig.</u>
Geometry of the system	1
Diagram of the interception phase	2
Record for Trial A	3
Record for Trial B	4
Record for Trial C	5
Record for Trial D	6
Record for Trial E	7
Record for Trial F	8
Tan $\alpha$ v. time curve for Trial E	9
Theoretical ray diagram for the special case	10
Tan $\alpha$ v. time curve for the special case	11

## 1 INTRODUCTION

At Aberporth a method of measuring the soalar miss distance of missiles which approach to within small distances of targets is needed.

In particular miss distance information is required for trials involving metallised parachute targets, as these trials are often carried out in bad weather and poor visibility, when optical coverage cannot be provided. For R.A.F. Bloodhound trials against parachutes the miss distances to be measured are of the order of 100 ft or less, for interception ranges of up to 50,000 yds. The method described below is intended to give miss distances of this order, in all weather conditions, without the need for any extra instrumentation either in the missile or in the target.

Other methods of measuring miss distance using the Doppler effect have been proposed<sup>1,2,3,4</sup> while beat frequencies on the M.T.S. signal from a missile were first recorded by D. Spenoer<sup>5</sup>.

## 2 THEORETICAL DISCUSSION

### 2.1 The M.T.S. system

Missiles fired at Aberporth against targets carry CW oscillators radiating at a frequency of about 4700 Mc/s, the transmitted power being 650 m-watts. Normally this signal is received by auto-following dish aerials at two or more ground stations. The elevation and azimuth angles of the dish axes are measured and fed into a computer which calculates the position of the missile and presents this on a safety break-up display. The angular data is also recorded on film for further use when necessary. This is known as the Missile Tracking System, abbreviated to M.T.S.

The miss distance method described in this Note makes use of the M.T.S. oscillator and receivers, but it is emphasised that the method can be applied to any convenient CW oscillator carried in the missile which radiates an unmodulated signal of sufficient power. A particular advantage of the M.T.S. oscillator is its ultra high frequency.

### 2.2 Doppler frequency shift of the M.T.S. signal received directly from the missile

As a missile is launched and moves away from the launcher, its velocity increases and hence there is a Doppler shift in the M.T.S. frequency received at the base set, which is close to the launchers. The same is true of the frequency received at the other M.T.S. station at O.P.6 which is some ten miles away from base. The frequency shift at O.P.6, however, will not be the same as that for the base receiver, since the Doppler frequency shift depends directly on the velocity component of the missile in a radial direction with respect to each receiver. If this radial velocity component is directed towards the receiving aerial then the received frequency will be higher than that transmitted at the missile, and vice-versa. For all cases which we need consider, the radial velocity component will be directed away from the ground receivers, so that the resulting Doppler shift will be a decrease in frequency.

Let the bearing and elevation of the missile from the M.T.S. receiver at time  $t$  be  $\theta$  and  $\phi$ , and suppose the missile velocity is  $V$  along the direction  $(\theta, \phi)$  as shown in Fig.1., The velocity and all these angles are available from normal trajectory data. We assume that the missile flight-path is a straight line during the small interval of time with which we are concerned. Let the frequency transmitted by the M.T.S. oscillator be  $F_0$ .

and its wavelength  $\lambda_0$ . Then it can be shown that the Doppler frequency shift of the direct signal received at the M.T.S. set to which  $\Theta$  and  $\Phi$  refer is given by:

$$\Delta F_1 = \frac{V}{\lambda_0} [\sin \phi \sin \Phi + \cos \phi \cos \Phi \cos(\Theta - \theta)] \quad (1)$$

Since the missile will always be moving away from the receiver, the frequency received directly from the missile will be:

$$F_0 - \Delta F_1 \quad (2)$$

As we are concerned with only a very short interval of time during which the missile passes the target, we can assume that all the quantities in equation (1) remain constant in this time, so that in fact  $\Delta F_1$  is also constant over this interval.

### 2.3 Doppler frequency shift of the M.T.S. signal received by reflection from the target

The missile-borne oscillator is designed to have an all-round polar diagram so that part of the transmitted energy arrives at the target. Some of this is reflected, the reflected energy depending on the amount of incident energy and on the reflecting characteristics of the target. The energy reflected in the direction of the M.T.S. receivers is received by these together with the direct signal from the missile, and it is the beat frequencies between the direct and reflected signals which we use to calculate miss distances.

There are two cases to consider, that of the stationary target and the moving target.

#### 2.3.1 Stationary target

Consider the plane drawn through the flight-path of the missile and the target as shown in Fig.2. Suppose that the angular distance of the missile from the position of nearest approach to the target is  $\alpha$  at time  $t$ . When the missile approaches the target,  $\alpha$  is positive; it decreases to zero at the instant of interception, and increases in the negative direction as the missile recedes from the target.

Now the Doppler shift of the M.T.S. frequency received at the target depends directly on the component of missile velocity radially with respect to the target. This radial component is given in magnitude and sense by the expression  $V \sin \alpha$ , if we assume that a radial component towards the target is positive, and one directed away from the target is negative. Therefore the Doppler frequency shift of the M.T.S. signal received at the target is given by:

$$\Delta F_2 = \frac{V \sin \alpha}{\lambda_0} \quad (3)$$

The actual frequency received by the target is:

$$F_0 + \Delta F_2 = F_0 + \frac{V \sin \alpha}{\lambda_0} \quad (4)$$

in which the sign of  $\alpha$  must be applied correctly.

Since we have assumed that the target is stationary, this signal is reflected without further change in frequency, and therefore the M.T.S. frequency received at the ground after reflection at the target is given by equation (4).

### 2.3.2 Moving target

The frequency received by a moving target is in general different from that received by a stationary target, since the relative radial velocity of missile-target is different. Denoting the relative velocity missile-target by  $V_R$  then the Doppler shift of the signal received at the target is given by:-

$$\Delta F_2 = \frac{V_R \sin \alpha}{\lambda_0} \quad (5)$$

so that the actual frequency received is:-

$$F_0 + \frac{V_R \sin \alpha}{\lambda_0} \quad (6)$$

where again the sign of angle  $\alpha$  must be applied.

Since the target is moving there is a further frequency shift  $\Delta F_2'$  in the signal received at ground after reflection, due to the radial velocity component of the target with respect to the receiver aerial. Therefore the frequency received at the ground after reflection is:

$$F_0 + \Delta F_2 + \Delta F_2' \quad (7)$$

In this equation the sign of  $\Delta F_2'$  depends on whether the target is moving towards or away from the receiver.

It is shown in the next section that the important quantity is the difference in frequency between the direct and reflected M.T.S. signals received. This difference is given by the expression:

$$\Delta F_1 + (\Delta F_2 + \Delta F_2') \quad (8)$$

in which  $\Delta F_1$  is calculated by equation (1). During the interception phase both  $\Delta F_1$  and  $\Delta F_2'$  remain constant, so that  $(\Delta F_1 + \Delta F_2')$  is also constant.

Expression (8) can be rearranged to the form:

$$(\Delta F_1 + \Delta F_2') + \Delta F_2 \quad (9)$$

Now since  $\Delta F_1$  in this expression varies directly with the radial velocity component of the missile and  $\Delta F_2'$  directly with the radial velocity component of the target, then  $(\Delta F_1 + \Delta F_2')$  varies directly with the radial component of  $V_R$ , the relative velocity missile-target. In other words

$(\Delta F_1 + \Delta F_2)$  can be calculated by equation (1) if we replace the missile velocity  $V$  by the relative velocity  $V_R$ . We have also shown in equation (5) that  $\Delta F_2$  may be calculated by replacing  $V$  by  $V_R$  in equation (3).

It turns out, therefore, that the case of a moving target can be dealt with by replacing the missile velocity  $V$  by the relative missile-target velocity  $V_R$  in equations (1) and (3) and treating the target as if it were stationary. To obtain  $V_R$  we have to add the missile velocity and target velocity vectorially.

#### 2.4 Beat frequency

The direct signal missile-receiver and the reflected signal missile-target-receiver are of different frequencies, and the difference varies with time. Two such signals of slightly differing frequencies interfere to produce two beat frequencies, one equal to their sum and the other equal to their difference.

The sum beat frequency, which in this case is of the order of 9500 Mc/s, is not considered in the present context.

The difference beat frequency is given, from equations (2) and (4), by:

$$\begin{aligned} F_0 + \Delta F_2 - (F_0 - \Delta F_1) \\ &= \Delta F_1 + \Delta F_2 \\ &= \Delta F_1 + \frac{V \sin \alpha}{\lambda_0} \end{aligned} \quad (10)$$

Bearing in mind the sign convention for angle  $\alpha$  in equation (10) we see that the beat frequency decreases from a high value when the missile approaches the target and  $\alpha$  is positive, to a value  $\Delta F_1$  at the instant of nearest approach, and falls away still further as  $\alpha$  increases in the negative direction.

The rate of change of  $\alpha$ , and hence of the beat frequency, is clearly a measure of the miss distance when the relative velocity of missile-target  $V_R$  is known. By recording the beat frequency and measuring its rate of change with time we have a method of calculating the miss distance  $D$ .

For a typical missile trial,  $\Delta F_1$  is of the order of 10 Kc/s, as is the frequency given by the expression  $V/\lambda_0$ . Inserting these values into the equation (10) we see that the beat frequency is initially of the order of 20 Kc/s and decreases to a few Kc/s as the missile moves away from the target.

#### 2.5 Range of operation

The beat frequency will only be detectable when there is sufficient reflected energy to modulate the direct signal. It is not known accurately what the ratio of the two signal strengths must be for the beat frequency to be detectable. Furthermore, the reflected energy depends not only on the separation of the missile from the target but also on the reflecting

properties of the target, which again are not known with great accuracy. For these reasons it is difficult to calculate the range of operation of the system. Experience has shown, however, that the detection limit is such that it should be possible to record beat frequency signals for miss distances of up to 100 ft at a range of 50,000 yards with metallised parachute targets. This is probably the extreme range of operation of the system with such targets. For aircraft targets the range of operation is expected to be rather less, since the effective echoing area is not as large as that of a metallised parachute.

### 3 EXPERIMENTAL TECHNIQUE

#### 3.1 Recording the beat frequency

The beat frequency is extracted from the normal M.T.S. receiver after the second detector and before reaching the l.f. filter. It must be taken from here since the l.f. filter rejects all frequencies above 70 cycles/sec, as tracking error signals are fed to the M.T.S. system at the rate of 33 cycles/second. The signal is led on a co-axial line either directly to the Y-plates of an oscilloscope and recorded on film together with a time base, or it is recorded on magnetic tape which is replayed onto an oscilloscope and a film record taken after the trial.

For the direct film recording a high camera speed is essential in order to distinguish individual cycles at the higher frequencies. The records shown in Figs.3, 4 and 5 were taken at a camera speed of 128 in/sec.

Using the tape recorder, however, one can effectively double the camera speed by replaying the tape at half-speed. Another advantage is that the tape recorder will only record frequencies between 50 c/s and 18 Ko/s approximately. This in effect cuts down the frequency pass-band of the receiver to exactly the limits we require, resulting in very little noise appearing on the beat frequency signal. This is apparent when we compare Figs.6, 7 and 8 which were recorded on tape, with Figs.3, 4 and 5 recorded directly on the oscilloscope. The tape recorder can be replayed more than once and if the first film record is unsuitable as regards brilliance or amplitude then another one can be taken. Furthermore, for all the records taken so far it has been possible to say that the missile passed near the target by replaying the recorder with a loudspeaker attached, when the beat frequency record is heard as a short, sharp whistling sound.

#### 3.2 Analysis of the record

The analysis of the film record consists of reading off the beat frequency at as many points as possible on the film. This is done by putting the film in an enlarger and projecting the image onto a large sheet of squared paper. At the high frequency end the number of squares corresponding to the length along the film of a certain whole number of cycles, say 10 or 20, is noted together with the number of squares corresponding to 0.001 seconds on the time ruler. The real time at the midpoint of the group of cycles is also noted. At the low frequency end it is possible to measure the length of individual cycles. In this way we get a table consisting of a large number of values of beat frequency against time from the instant of fire.

When measuring the length of a group of cycles care must be taken in choosing a group in which all the cycles are smooth and regular. Occasionally there seem to be irregularities in the cycles. These are probably due to various phase changes due to missile roll, change in the angle of incidence at reflection or some other causes. The varying amplitude of the beat frequency signal is probably also due to these effects.

Since the beat frequency varies directly as the basic frequency  $F_0$ , we see that the ultra high value of  $F_0$  is an advantage; if  $F_0$  were much lower then we would have a much smaller number of cycles to deal with.

### 3.3 Calculation of miss distance

We now have a table of values of beat frequency against time. The next step is to calculate the value of  $\Delta F_1$ , using equation (1) and remembering that  $V_R$ , the missile-to-target relative velocity, is to be substituted for  $V$  in the case of moving targets.

$\Delta F_1$  is subtracted from each beat frequency value, leaving a table of values of  $\Delta F_2$  against time.

Now since

$$\Delta F_2 = \frac{V \sin \alpha}{\lambda_0}$$

from equation (10) we can calculate a value for  $\sin \alpha$  corresponding to each value of  $\Delta F_2$ . So we can finally obtain a table of values of angle  $\alpha$  against time.

Refer now to Fig.2. Suppose the time of nearest approach is denoted by  $t_1$ . At time  $t$  the distance of the missile from the point of nearest approach measured along the flight-path is  $V(t_1 - t)$  and we can put down the expression:-

$$\begin{aligned} \tan \alpha &= \frac{V(t_1 - t)}{D} \\ &= \frac{V t_1}{D} - \frac{V t}{D} \end{aligned} \quad (11)$$

From this equation it follows that if we plot  $\tan \alpha$  against time  $t$  then we will have a straight line graph whose gradient relative to the time axis is given by  $-V/D$ .

The miss distance  $D$  is now given by:

$$D = \frac{-V}{\text{Gradient of line}} \quad (12)$$

The gradient is negative because  $\alpha$ , and therefore  $\tan \alpha$ , decreases with increase in time.

The instant of interception is the instant at which  $\alpha$ , and hence  $\tan \alpha$ , is zero. Thus we get the interception time directly from the straight line graph.

It is emphasised that  $V_R$  must be substituted for  $V$  throughout this section when dealing with a moving target.

#### 4 RESULTS

##### 4.1 Aircraft targets

The four beat frequency records reproduced in Figs.3-6 were obtained from trials of missiles against aircraft targets. Details of the individual trials are as follows:-

Trial A The target was a Meteor aircraft at 23,500 yds slant range at interception.

The M.T.S. method gave these results:

Miss distance 65.5 ft. Interception time 44.592 seo.

Pod cameras gave the results:

Miss distance 56 ft. Interception time 44.597 seo.

Trial B The target was a Meteor aircraft at 23,000 yds slant range at interception.

The M.T.S. miss distance results were:

Miss distance 32.1 ft. Interception time 43.265 seo.

Pod camera results were:

Miss distance 23.4 ft. Interception time 43.266 seo.

Trial C The target was a Meteor aircraft at 35,000 yds slant range at interception.

The M.T.S. method gave the results:

Miss distance 51.5 ft. Interception time 60.740 seo.

Pod cameras failed to operate on this trial.

In addition to these, records were obtained for two trials in which the missile struck the target and destroyed it. These direct hits were indicated by a cut-off in the beat frequency record at the time of intercept. Trial D was one of these two, and the record is reproduced in Fig.6.

##### 4.2 Parachute targets

Beat frequency records were taken during three trials of missiles against parachute targets.

For the first trial there was a sharp out-off of the beat frequency at about 10 Kc/s indicating a direct strike at a time which agreed very closely with that of disturbances on the telemetry and multi-station-doppler records.

For the second trial (Trial E) the parachute target was at a slant range of 33,000 yds from base at interception time.

Records were obtained both at base and at O.P.6, the one taken at O.P.6 being reproduced in Fig.7. The results calculated for Trial E were:

Base record: Miss distance 25.8 ft. Interception time 54.455 secs.  
 O.P.6 record: " " 29.5 ft. " " 54.453 secs.

For the third trial (Trial F) the parachute was at a slant range of 44,000 yds from O.P.6 at the time of interception.

The record taken at O.P.6 is shown in Fig.8 and the results obtained for Trial F were:

Miss distance 107 ft. Interception time 66.198 secs.

There was no optical coverage on any of these parachute trials, as they took place in bad weather and poor visibility.

## 5 COMMENTS ON THE RESULTS

When values of  $\tan \alpha$  are plotted against time  $t$  it is found that the points do not lie on a straight line but that the best fit is a slight curve whose slope gradually increases with time. Fig.9 is a reproduction of the curve obtained from the O.P.6 record for Trial E.

Since miss distance varies inversely as the gradient as shown in equation (12), the calculated values of miss distance decrease steadily with time when we take tangents to the curve at several times and insert the gradient of each tangent in equation (12). Assuming that the lowest calculated value is the most accurate value of miss distance, all we need do is to draw the tangent at the latter end of the curve and work out the corresponding value of  $D$ . This is not as inaccurate as it might seem since the deviation of the curve from a straight line is not very large.

It is shown in the Appendix that such a trend in the values of miss distance calculated at different times can be expected if the signal is reflected from a convex surface, such as the upper half of a parachute target, or the fuselage, engine nacelles or even the wings of an aircraft target. In the theory in section 2 we assumed that reflection takes place from a single point but in actual fact the reflection point moves along the target as the missile goes past it, and this is probably the reason why the  $\tan \alpha$  - time points fit a smooth curve as shown in Fig.9 and not a straight line.

It is difficult to make an estimate of the discrepancy in calculated miss distance brought about by this effect. Some attempt may be made for a parachute target which is approximately hemi-spherical in shape, but even then it is very difficult unless we know the relative trajectory during the interception phase, i.e. whether the missile passed to one side of or directly over the target.

Thus a target with a convex reflecting surface as indicated in the Appendix gives a value of miss distance which is larger than it should be and a time of interception which is earlier than the true interception time. There is some evidence that the missiles in Trials E and F both passed above and to one side of the centre of the parachute, in which case the reflecting surface is convex.

The conclusions arrived at in the Appendix seem to be borne out in the results for Trials A and B, for which the miss distances calculated are several feet on the large side, while the interception times calculated by the M.T.S. method are in both cases earlier than those calculated from pod camera information.

The small discrepancies between the results calculated from the two records obtained in Trial E can also be explained by the convexity of the parachute and the angle between the lines of sight from base and O.P.6 to the target.

## 6 CONCLUSIONS

It has been shown that the method is usable and that miss distances of up to 100 ft can be measured at slant ranges of at least 45,000 yds and probably beyond 50,000 yds.

In the only two trials for which optical coverage was available, the method gave larger miss distances and shorter interception times than those calculated from the optical records. It is shown in the Appendix that at least part of these discrepancies is probably caused by the convexity of the reflecting surfaces, but due to the complex surface geometry of the aircraft no quantitative estimates can be made.

The results for Trial E show that the system is self-consistent and the small discrepancies between the two sets of results seem to support the theory set out in the Appendix.

Due mainly to the movement of the point of reflection over the target surface, the accuracy of the method is probably about  $\pm 10$  ft in miss distance and about  $\pm 0.005$  seconds in interception time. The miss distance is quoted from the nearest reflecting surface of the target.

## 7 RECOMMENDATIONS FOR FURTHER WORK

Records should be taken for all possible trials, especially when optical coverage is possible. Comparison of results with optical results will enable a better accuracy estimate of the system to be made and will show if the theory advanced in the Appendix is applicable.

## 8 ACKNOWLEDGEMENTS

Thanks are due to Mr. J.E.A. Harrison, who has supervised the work throughout, and to Mr. D. Spencer who has assisted in obtaining and analysing the film records.

## LIST OF SYMBOLS

$\Theta$	Bearing of missile from receiver
$\Phi$	Elevation of missile from receiver
$\theta$	Heading angle of missile in bearing
$\phi$	Heading angle of missile in elevation
$V$	Missile velocity
$V_R$	Relative velocity of missile with respect to the target
$F_0$	Frequency radiated by the M.T.S. oscillator
$\lambda_0$	Wavelength radiated by the M.T.S. oscillator
$\Delta F_1$	Doppler frequency shift of the direct signal
$\Delta F_2$	Doppler frequency shift of the reflected signal
$\alpha$	Angular distance of the missile from point of nearest approach
$t_i$	Time of interception
$D$	Miss distance

LIST OF REFERENCES

<u>No.</u>	<u>Author</u>	<u>Title, etc.</u>
1	Mallett, E.S.	Soalar miss distance measurement by a Doppler method. R.A.E. Tech. Note No. TD.53. July, 1960.
2	Shimmins, A.J.	A method of miss distance measurement. E.M.I. (Australia) Ltd. Report No.71. 1955.
3	Shimmins, A.J.	An electrical method of instrumenting interception phase. E.M.I. (Australia) Ltd. Report No.78. 1955.
4	Shimmins, A.J.	Analysis of interception traces from Fireflash trials. E.M.I. (Australia) Ltd. Report No.114. 1956.
5	Spencer, D.S.	Investigation of the interference effect observed when a missile carrying a C.W. oscillator is released from an aircraft. R.A.E. Tech. Memo. TD.61. June, 1960.

ATTACHED

Appendix  
Drgs. Nos. TD/P.578 - 581  
Negs. Nos. 151,898 - 151,899  
Detachable abstract cards

ADVANCE DISTRIBUTION LISTM.O.A. Headquarters

Chief Scientist  
GW(G&C)5 70  
TIL 1(b) 90  
DGWT  
GW(A)  
GW(A) 1(a)  
GW(A) 2(a)  
GW(SR)  
AL5

Royal Aircraft Establishment

Director  
DD(E)  
Patents  
Head of Trials Dept  
Supt, RAE, Aberporth  
Officer in Charge, Llanbedr  
Officer in Charge, Larkhill  
Officer in Charge, West Freugh

## Others:

TEGWRA, Ty Croes  
UKDRSS 3  
BJSM 2

APPENDIXREFLECTION FROM A CONVEX SURFACE

For simplicity suppose we have a spherical reflecting surface, and that the missile flight-path, the direct and reflected rays and the locus of the moving point of reflection are all in the same plane, as shown in Fig.10. In the general case no such plane can be drawn.

We will assume that the angle of incidence of a ray is equal to its angle of reflection. Then we can draw geometrically the reflected rays when the missile is at different points A, B, C .... along its flight-path.

If we extend the incident rays from points A and B until they intersect at G then we see that the calculated miss distance for a time midway between those of A or B will really be the perpendicular distance of the point G from the missile path.

A little later in time, when the missile is midway between B and C the calculated miss distance is the perpendicular distance of H from the missile path.

So in this special case the calculated values of miss distance decrease as the times for which they are calculated increase. The calculated values tend towards the real miss distance from the nearest point on the reflecting surface.

Plotting the values of  $\tan \alpha$  against time for this special case we get a smooth curve, as shown in Fig.11, which can be compared with Fig.9, obtained for Trial E. We see that for the special case, the most accurate value of the miss distance would be obtained by drawing a tangent at the latter end of the curve shown in Fig.11.

In the general case the locus of the reflecting point is not part of a circle but the same argument applies as above, so that the most accurate calculated value of miss distance is derived from the tangent drawn at the latter end of the  $\tan \alpha$  - time curve.

The M.T.S. method gives the instant of interception as the time when angle  $\alpha$  is zero, i.e. when the missile radial velocity is zero relative to the point of reflection. From Fig.10 we see that the interception time in this sense is the time when the missile is at point D, whereas the real time of intercept is when the missile is at point E.

In general, therefore, we can expect the interception time given by this method to be earlier than the real interception time, for a convex target surface. Moreover, the calculated interception time depends on the line of sight to the ground receiver, so that two receivers at an appreciable angular separation viewed from the missile, will yield results which differ in interception time and also in miss distance. For a 20 ft diameter parachute, the distance DE in Fig.10 is about 7 ft, so that the discrepancy between calculated and real interception time for the special case shown in Fig.10 will be of the order of 0.003 seconds.

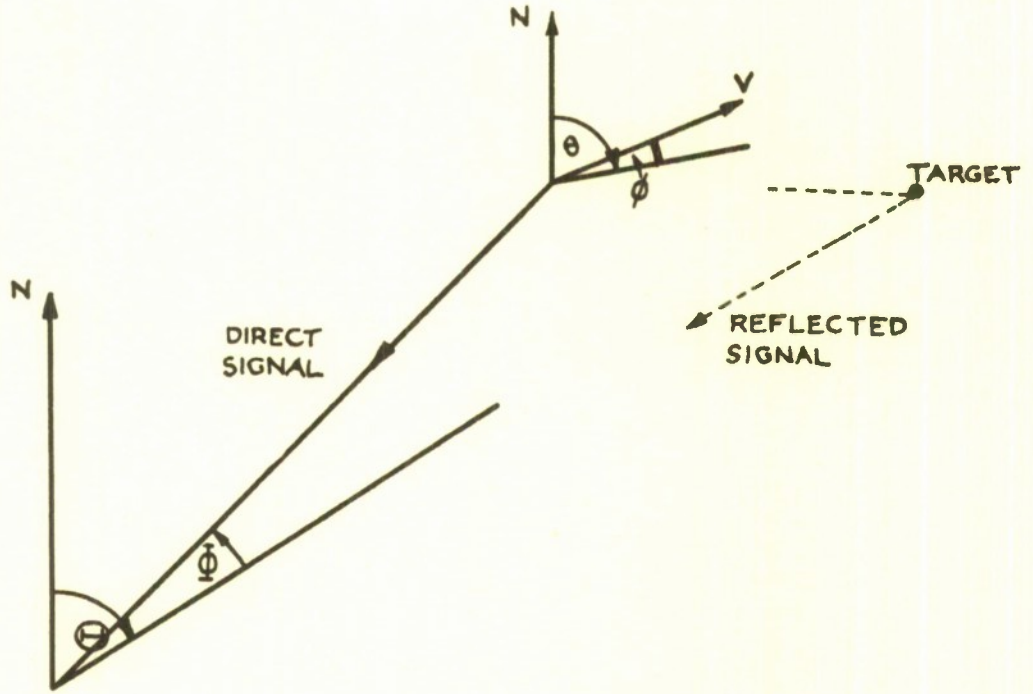

FIG. I. GEOMETRY OF THE SYSTEM

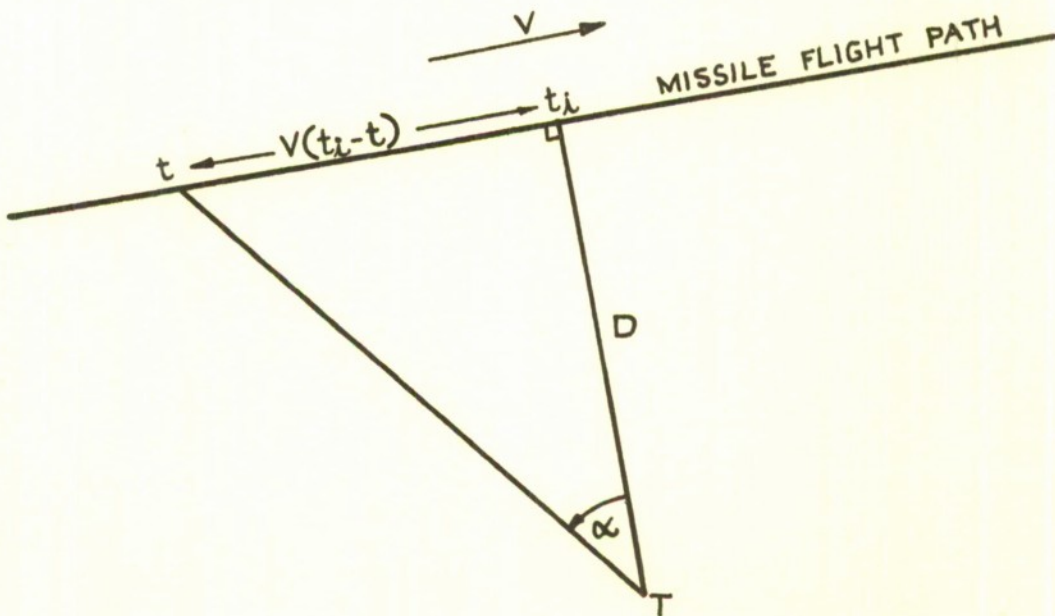

FIG. 2. DIAGRAM OF THE INTERCEPTION PHASE.

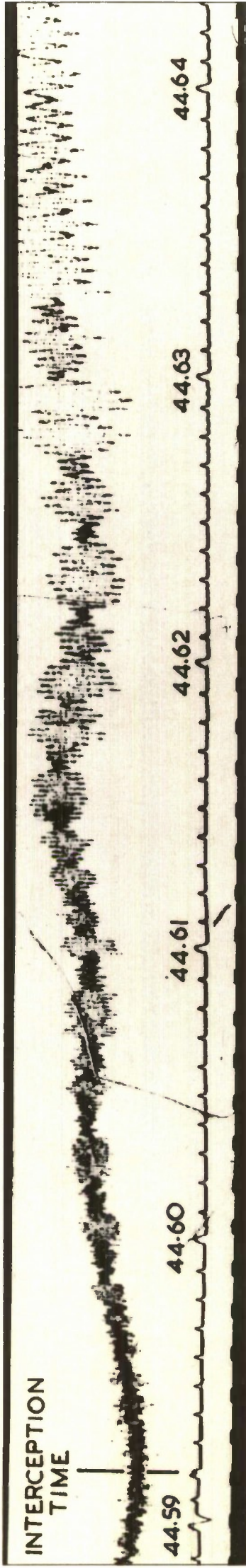

FIG.3. RECORD FOR TRIAL A



FIG.4. RECORD FOR TRIAL B

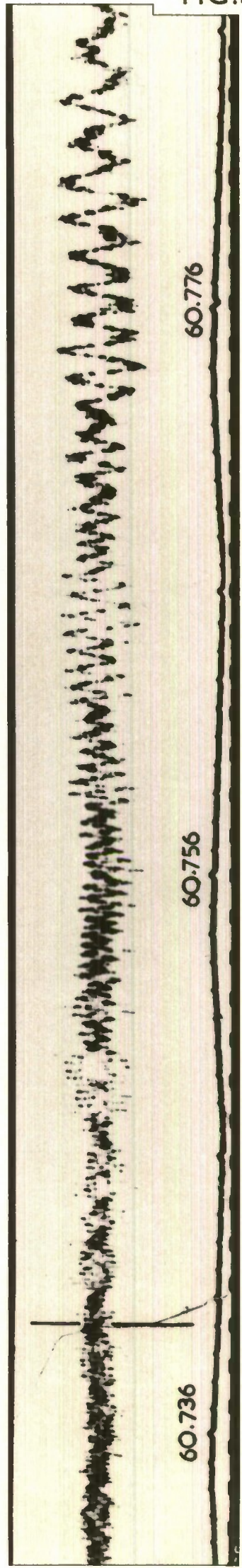

FIG.5. RECORD FOR TRIAL C

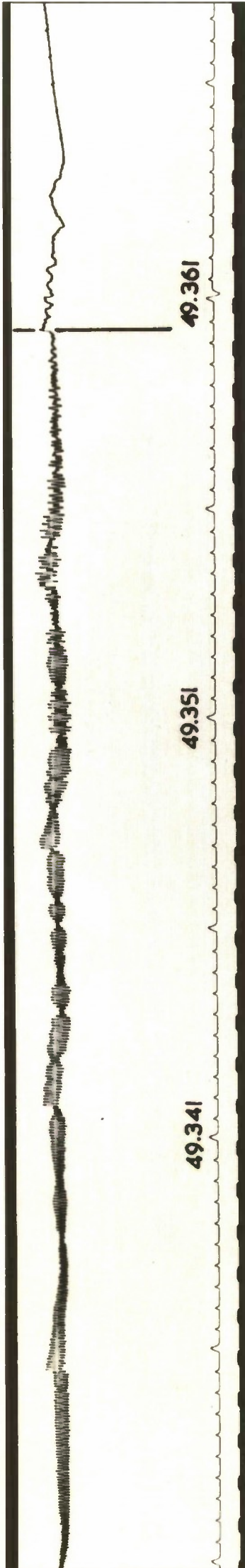

FIG.6. RECORD FOR TRIAL D

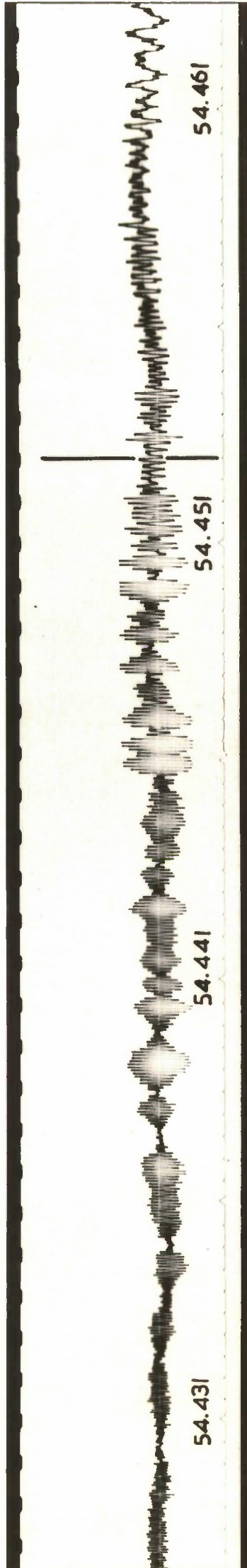

FIG.7. RECORD FOR TRIAL E

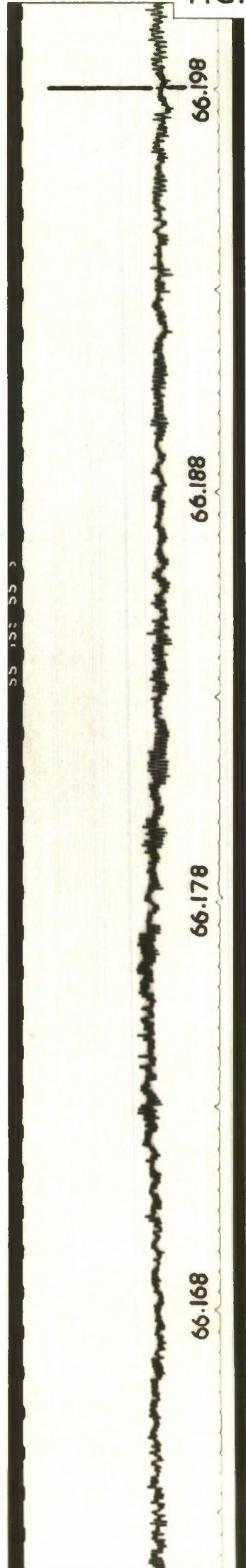

FIG.8. RECORD FOR TRIAL F

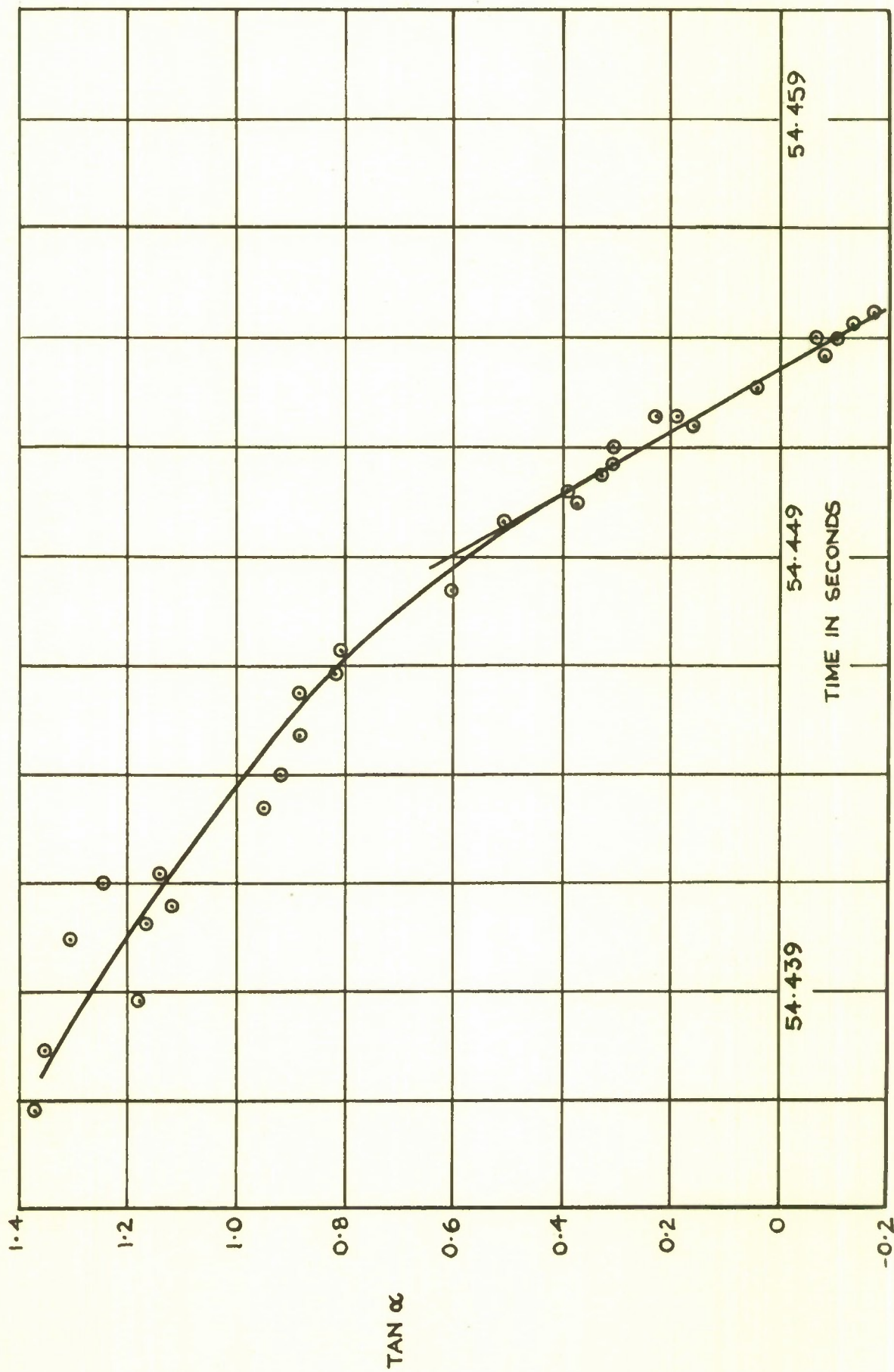

FIG. 9. TAN  $\alpha$  v TIME CURVE FOR TRIAL E.

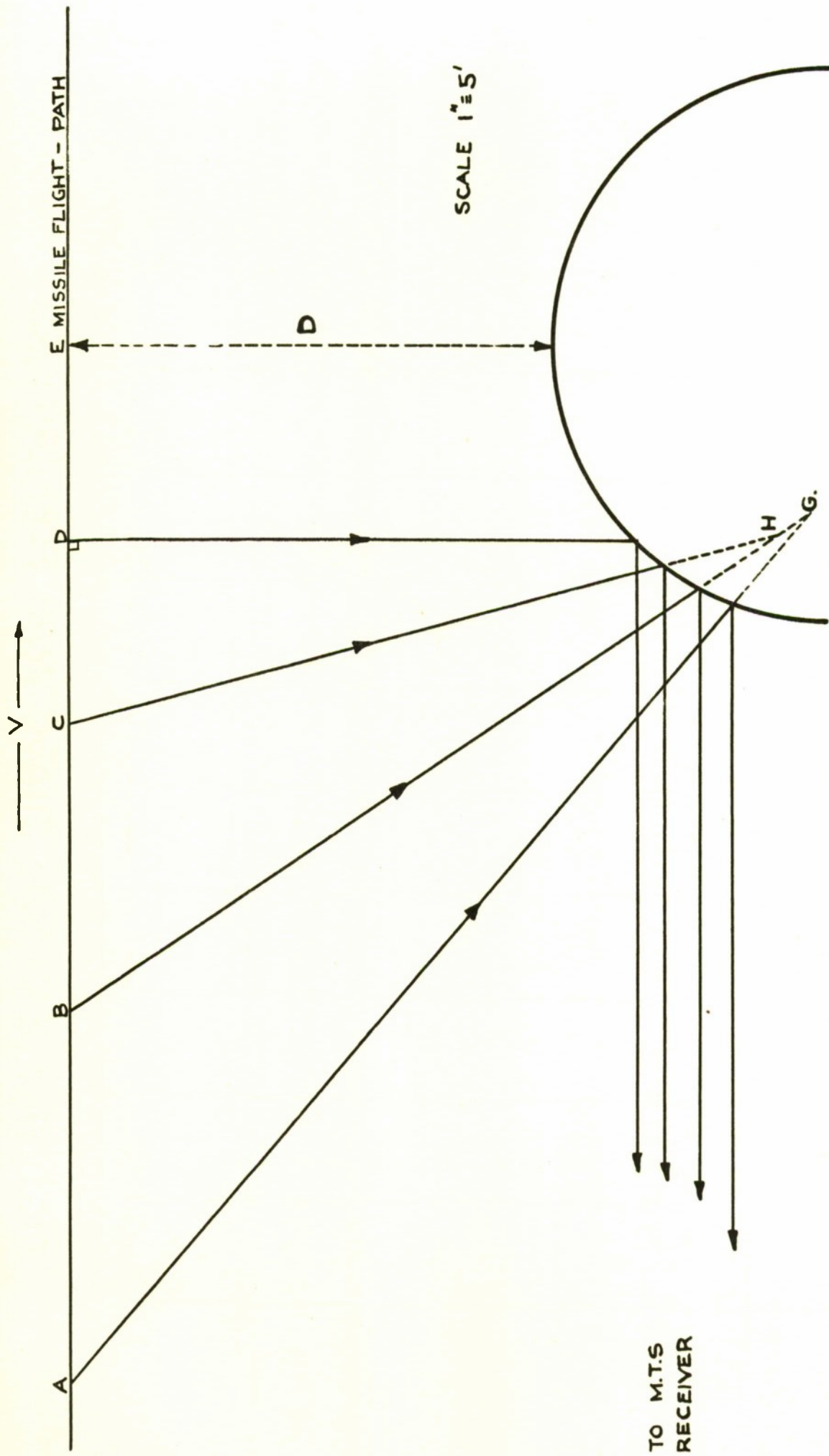

FIG. 10. THEORETICAL RAY DIAGRAM FOR THE SPECIAL CASE.

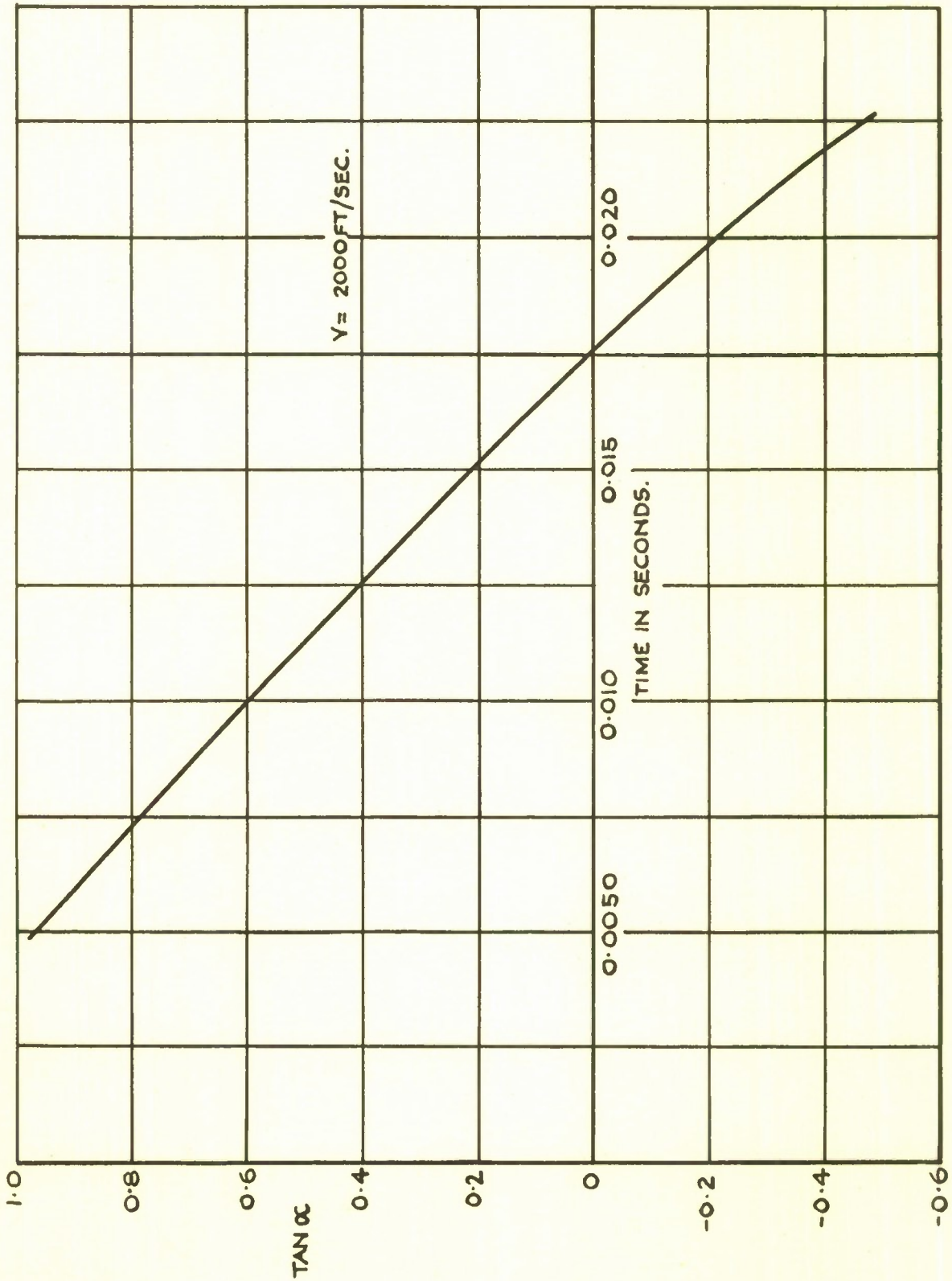

FIG. II. TAN  $\alpha$  v TIME CURVE FOR SPECIAL CASE.



*Information Centre  
Knowledge Services  
[dstl] Porton Down,  
Salisbury  
Wilts  
SP4 0JQ  
22060-6218  
Tel: 01980-613753  
Fax 01980-613970*

Defense Technical Information Center (DTIC)  
8725 John J. Kingman Road, Suit 0944  
Fort Belvoir, VA 22060-6218  
U.S.A.

AD#: AD325843

Date of Search: 11 December 2008

Record Summary: AVIA 6/23857

Title: Method of measuring scalar miss distance using a CW oscillator in the missile  
Availability Open Document, Open Description, Normal Closure before FOI Act: 30 years  
Former reference (Department) Technical Note No Td58  
Held by The National Archives, Kew

This document is now available at the National Archives, Kew, Surrey, United Kingdom.

DTIC has checked the National Archives Catalogue website (<http://www.nationalarchives.gov.uk>) and found the document is available and releasable to the public.

Access to UK public records is governed by statute, namely the Public Records Act, 1958, and the Public Records Act, 1967. The document has been released under the 30 year rule. (The vast majority of records selected for permanent preservation are made available to the public when they are 30 years old. This is commonly referred to as the 30 year rule and was established by the Public Records Act of 1967).

This document may be treated as **UNLIMITED**.