

UNCLASSIFIED

AD NUMBER

AD326790

CLASSIFICATION CHANGES

TO: unclassified

FROM: restricted

LIMITATION CHANGES

TO:
Approved for public release, distribution unlimited

FROM:
Controlling Organization: British Embassy,
3100 Massachusetts Avenue, NW, Washington,
DC 20008.

AUTHORITY

DSTL, AVIA 6/19001, 29 Jul 2008; DSTL,
AVIA 6/19001, 29 Jul 2008

THIS PAGE IS UNCLASSIFIED

CONFIDENTIAL

MODIFIED HANDLING AUTHORIZED

AD 326 790

*Reproduced
by the*

ARMED SERVICES TECHNICAL INFORMATION AGENCY
ARLINGTON HALL STATION
ARLINGTON 12, VIRGINIA



CONFIDENTIAL

MODIFIED HANDLING AUTHORIZED

NOTICE: When government or other drawings, specifications or other data are used for any purpose other than in connection with a definitely related government procurement operation, the U. S. Government thereby incurs no responsibility, nor any obligation whatsoever; and the fact that the Government may have formulated, furnished, or in any way supplied the said drawings, specifications, or other data is not to be regarded by implication or otherwise as in any manner licensing the holder or any other person or corporation, or conveying any rights or permission to manufacture, use or sell any patented invention that may in any way be related thereto.

November, 1961

XEROX

ROYAL AIRCRAFT ESTABLISHMENT

(FARNBOROUGH)

A NOTE ON THE USE OF THE MOON AND PASSIVE SATELLITES
FOR LONG DISTANCE COMMUNICATION (U)

by

J. E. Clegg

EXCLUDED FROM AUTOMATIC
REGRADEING: DOD DIR 5200.10
DOES NOT APPLY

326790

This document contains information affecting the National Defense of the United States within the meaning of the Espionage Laws, Title 18, U.S.C. Section 793 and 794. Its transmission or the revelation of its contents in any manner to an unauthorized person is prohibited by law.

1 INTRODUCTION

Several groups of workers have demonstrated that it is possible to bounce radar signals and to send radio messages over long distances by reflecting the waves from the surface of the Moon. Telegraph type messages have been transmitted from Jodrell Bank to Sydney which are separated by 150 degrees of longitude and 80 degrees of latitude (January, 1961).

Speech has been transmitted from California to Woomera (February, 1961), though of poor quality.

Present methods of long distance communications are neither adequate nor reliable. H.F. radio waves, which are reflected off the ionosphere, are used but at times communication is interrupted because of unsatisfactory propagation conditions. Also the number of channels available is small because of the narrowness of the h.f. spectrum and the small number of channels available has to be shared among many users. The insecurity of h.f. radio transmission also limits its usefulness for military purposes.

Unfortunately the Earth has only one Moon so it is not possible to provide continuous communication to all parts of the world by using the Moon alone. However it is probable that artificial satellites will be put into orbit within the next few years which can be used in a similar fashion. Already experience has been obtained with one such satellite - Echo I - which is encouraging.

2 THE AMPLITUDE OF THE RETURNED SIGNAL

It is possible to calculate the amplitude of the signal which is reflected from the Moon by the following formula:

$$P_r = \frac{P_t K^2 A^2 \sigma}{4\pi d^4 \lambda^2} \quad (1)$$

where P_r is the power received

P_t is the power transmitted

A is the collecting area of the transmitting and receiving aeriels



K is the factor to allow for the imperfect illumination of the "dish"
(a value of 0.7 will be assumed)

σ is the "echoing area" of the Moon

d is the distance to the Moon

λ is the wavelength

A value of $0.014\pi a^2$, where 'a' is the lunar radius, is given by Hey and Hughes¹ for the scattering cross section of the Moon measured at 3,000 Mc/s. As the lunar radius is 1,080 miles the value of σ in MKS units is

$$\sigma = 1.3 \times 10^{11} \text{ sq metres} \quad (2)$$

Because the surface of the Moon is rough and moving relative to the Earth, the signals reflected back fluctuate and this must be considered when devising a practical system.

3 DISTORTION OF THE SIGNAL IN TIME

Because of the great distance of the Moon from the Earth the signal takes about $2\frac{1}{2}$ seconds to return to the Earth. This makes it very difficult indeed to carry on a two-way telephonic conversation but does not 'distort' the signal in the accepted sense. However, because the returned signal is made up of contributions from a large area of the Moon some components of the signal have travelled further than other parts, and this gives rise to what might be called a 'time smear'. The effect has been investigated by Hey and Hughes¹ who measured the time delay effects using pulses of 5 microseconds duration. From their work it appears that for monostatic working (i.e. transmitting and receiving at the same site), the leading edge of a pulse rises steeply with little delay whilst the trailing edge takes about 100 microseconds to decay to half amplitude. This is because most of the signal returns from the centre of the Moon's disc: unlike light waves which are uniformly scattered from the whole disc. For centrimetric radio waves most of the energy appears to be scattered back from the central 10% of the disc.

For bistatic (i.e. between stations far apart) transmission, the leading edge rises slowly, reaching half amplitude in about 50 microseconds and the trailing edge decays to half amplitude in 100 microseconds. Because of this time smear it is difficult to make use of pulses at a higher repetition rate than about 5,000 p.p.s.

4 DISTORTION IN FREQUENCY

Because of the relative motion of the Earth and Moon the frequency of the returned signal will be changed. As the Moon rises over the horizon a signal frequency transmitted at say, 3,000 Mc/s will be received at a frequency about 6 kc/s higher. The actual shift in frequency depends on the relative positions of the transmitter and receiver and on the orbital path of the Moon at that particular time. As the Moon passes over, the shift in frequency decreases until when it is near its point of nearest approach the shift will be zero. This shift need not cause a distortion of the received signal for its magnitude can be calculated and allowed for in the receiver.

RESTRICTED
U. S. CONFIDENTIAL
MODIFIED HANDLING AUTHORIZED

Technical Memo. No. GW 402

However, as for the time delay, there is a secondary effect which causes a spread in the received frequency which will cause distortion. The Earth-Moon geometry is described in Fig.1. The Moon subtends an angle of about 0.5 degrees to a point on the Earth and the Doppler shift of signals from different parts of the Moon's surface will therefore differ slightly and this gives rise to the frequency 'smear'.

The relative motion between a point on the Earth and the Moon is due to:

- (a) The rotation of the Earth on its own axis.
- (b) The rotation of the Moon on its axis.
- (c) The orbital motion of the Moon around the Earth.

The Earth revolves on its axis once in 24 hours and the Moon revolves around the Earth once in 27 days. The plane of the Moon's orbit is at present inclined at 19 degrees to the Earth's Equator. This varies from year to year on an 18 year cycle. Always the orbital plane of the Moon is inclined at 5 degrees to that of the Earth around the Sun. The declination of the Moon therefore varies at present during the lunar month from plus to minus 19 degrees. The 18 year cycle began in 1960 when the maximum declination was 18 degrees. In 1969 the maximum declination will be 29 degrees.

Let us consider the point in the lunar month when the declination of the Moon is zero then the velocity of a point on the Equator relative to the Moon when the Moon is on the horizon will be about 9,000 c/s and at latitude λ it will be

$$9,000 \cos \lambda \quad \text{cps .}$$

The spread in frequency will be sensibly zero. When the elevation of the Moon above the horizon is, say 10 degrees, there will be a little spreading as depicted in Fig.2(e). The spreading will be a maximum when the Moon is overhead as shown in Fig.2(c).

If the Moon scattered back the signals uniformly from its surface the spectrum would be about 80 c/s wide but because most of the energy is reflected from the centre of the disc the spectrum is narrower than this as shown in Figs.2(b) and 2(d). Hey¹ found that the ratio of scattered to incident power σ_1 can be represented by

$$\sigma_1 \propto \text{Exp}(-10\theta)$$

where θ is the angle of incidence at the mean surface. Thus the scattered power will be reduced by 3 dB when $\theta = 4$ degrees. The amplitude distribution across the disc will thus be as shown in Fig.2(b).

Recent measurements at J.P.L.² indicate that the scattered power falls off as

$$(\cos^2 \theta)^{50}$$

which gives a 3 dB reduction for 1.5 degrees angles of incidence - a similar value to that given by Hey. There is some evidence to show that the spectrum

U. S. CONFIDENTIAL
RESTRICTED
MODIFIED HANDLING AUTHORIZED

width is of the order of 10 c/s^2 but the width will depend on the latitudes and longitudes of the transmitting and receiving sites as well as on the angles of elevation and declination of the Moon.

The rotation of the Earth is the only motion that can contribute significantly to the spreading of the spectrum. This is because the Moon always presents the same side to the Earth and hence there is little differential movement between the edges of the Moon's disc and the Earth. The eccentricity of the Moon's orbit does however give rise to a radial velocity component which can contribute a Doppler shift to about 800 c/s. The eccentricity of the Moon's orbit is about 0.05 and this causes a cyclical variation in radial velocity of about 70 knots. This shift will be independent of latitude and will be a constant amount which must be added algebraically to the shift produced by the Earth rotation. This latter will of course be very sensitive to latitude and will be zero at the poles.

5 BANDWIDTH

Because of the 'time smear' it is difficult to make use of a bandwidth greater than about 5,000 c/s, the upper limit depending on the amount of distortion which can be tolerated. However because of the $2\frac{1}{2}$ seconds delay in transmission it is unlikely that a Moon circuit could be used for a normal telephonic conversation. There may, however, be special classes of users, such as the defence services, who could tolerate both the delay time and the distortion. The chief use of a Moon circuit would seem to be for a few teletype channels. For example 8 teletype channels could be accommodated in a bandwidth of 1 kc/s. If speech has to be transmitted it might be worthwhile to use one of the speech compression devices now being developed. Speech of reasonable quality can be compressed into a bandwidth of 200 c/s.

6 CHOICE OF CARRIER FREQUENCY

The frequency must be high enough to penetrate the ionosphere and this imposes a lower limit of a few hundred megacycles per second. An upper limit is set by atmospheric absorption which is serious above 10,000 Mc/s. The effect of heavy rain also becomes increasingly serious above 6,000 Mc/s and makes the use of frequencies above 6,000 Mc/s not attractive.

Cosmic noise dominates the background noise below 1,000 Mc/s and gradually decreases until above 3,000 Mc/s it becomes negligible. The frequency, therefore, should be chosen somewhere in the band 2,000 - 6,000 Mc/s. Before a final choice is made, several other factors must be taken into account, including international frequency allocation agreements, possible interference with other services such as radar, the availability and cost of transmitting valves, and economic factors involved in aerial design.

7 SIGNAL TO NOISE RATIO

Let us consider the transmission of eight teletype messages simultaneously. This will require a bandwidth of about 1,000 c.p.s. and to achieve a reasonable freedom from error will require an output signal to noise ratio of about 30 dB.

The input noise background will depend largely on the noise temperature of the aerial circuit. The beamwidth of the aerial is likely to be less than half a degree, the diameter of the Moon's disc, and so the background temperature will largely be that due to radiation from the Moon's

surface. This in turn will depend on the surface temperature of the Moon and hence will vary throughout the lunar month. The background temperature is therefore not likely to be less than 200°K nor greater than 400°K. There is thus little to be gained by using very low noise input circuits. A parametric amplifier will probably be adequate rather than a maser.

For a receiver with an input temperature of 290°K the noise power in a bandwidth of 1,000 c.p.s. will be

$$P_n = 4 \times 10^{-18} \text{ watts .}$$

The signal power required will therefore be

$$4 \times 10^{-15} \text{ watts} \quad (3)$$

Referring to equation (1) we have:

$$P_r = P_t \frac{K^2 A^2 \sigma}{4\pi d^4 \lambda^2}$$

Let us substitute some likely values, as follows:-

$$P_t = 5 \text{ kW}$$

$$K = 0.7$$

$$D = 20 \text{ metres (diam. of dish)}$$

giving

$$A = 314 \text{ sq metres}$$

$$\sigma = 1.4 \times 10^{11} \text{ sq metres} \quad \text{from Equation (2)}$$

$$d = 3.8 \times 10^8 \text{ metres}$$

$$\lambda = 0.1 \text{ metres}$$

Hence

$$P_r = 1.2 \times 10^{-14} \text{ watts} \quad (4)$$

which is about 5 dB more than required as indicated by Equation (3). A more sophisticated modulation system will improve the S/N ratio. However, the simple calculation above shows that the values chosen are of the right order. The right economic balance must be struck between the power output from the transmitter and the size of the aerial. An aerial of 20 metres diameter is quite practicable but nevertheless quite costly; say about £50,000 for a frequency of 3,000 Mc/s (see Fig.3).

8 OPERATIONAL CONSIDERATIONS

The Moon travels in an orbit which is inclined at 5 degrees 8 minutes to the Ecliptic and the orbital period is 27 days 8 hours. As the Moon moves around the Earth in the same direction as the Earth spins on its own axis, the Moon appears to an observer on the Earth to move round the Earth about once every 25 hours.

The number of hours per day that communication can be maintained between two points on the Earth via the Moon varies between zero and twelve. As the longitudinal separation increases the number of hours that a Moon circuit can be used decreases. For example, London and Ottawa which are 75 degrees of longitude apart, could maintain communication by a Moon circuit for about 6 hours per day. London and Sydney which are 150 degrees of longitude apart could only communicate directly for about 1 hour per day. Sydney and Vancouver could be linked for 5 hours per day.

The number of hours available per day varies considerably during the lunar month and the amount of variation depends on the year. For example the range of variation was a minimum in 1960 and will be a maximum in 1969. A useful nomogram for calculating the time availability is given in Ref.3.

Antipodal points may be connected through an intermediate relay station where the messages would be stored for about 5 hours before being passed on to the antipodal station. For example, the channel from Sydney to London could be operated for 6 hours per day from Sydney to Gan (at longitudes 150 and 75 degrees East respectively). The messages could then be stored at Gan for 5 hours before being relayed to the U.K. The link from U.K. to Australia could be made via relay stations at say Ottawa and Christmas Island (longitude 160° West). The messages would be stored at Ottawa for 4 hours, and at Christmas Island for a further 4 hours, giving a total delay of 8 hours.

The particular hours of the day when a Moon circuit can be used will, of course, change gradually during the lunar month.

10 ARTIFICIAL SATELLITES

As the Earth has only one Moon it is not possible, using this alone, to provide a full communication service between all points on the Earth at all times of the day. To do this would require either three moons equally spaced around the Earth or a multiplicity of moons in random orbits. It is unlikely that we will ever put artificial satellites, for communication use, into orbits as high as that of the Moon for they would then have to be impossibly large. However, it is probable that we shall soon have suitable passive satellites orbiting the Earth in comparative low orbits. Already partial success has been achieved with Echo 1. The U.S.A. plan to put several bigger and better passive satellites into orbit at a height of about 1,500 miles in the next few years. These could be used to supplement Moon circuits and so provide more cover and more operational time. For some years it will not be possible to provide a continuous world-wide service but as more satellites become established the service can be extended.

It is unlikely that passive satellites will be able to 'keep station' for a long period after launch though consideration is being given to putting several into orbit launched by the same vehicle. This will enable them to be evenly distributed in the same orbit initially. Without 'station-keeping' a very large number of satellites would be required to provide uninterrupted communication throughout the day.

It is probable that largerechoing areas than can be obtained from a sphere will be achieved by stabilising the passive satellite so that it always points to the Earth and by making it of suitable shape. This will enable either more channels or cheaper ground equipment to be used.

The ground equipment required to work with passive satellites is similar to that required for use with the Moon except that in the case of the passive satellite the aerial system has to follow at angular rates about four times that required for Moon following.

It would seem sensible to set up Moon circuits initially and extend them later to use passive satellites.

11 SECURITY

(a) Listening

It would be certainly possible for an enemy to listen to a teletype transmission via the Moon circuit but this would be expensive and unless done thoroughly might not be effective. Firstly, several listening stations would be needed, suitably located geographically and, secondly, they must be equipped with a big dish, at least 60 feet in diameter. This latter makes it difficult to listen aboard a ship, for the aerial must be pointed at the Moon with an accuracy of about 0.2 degrees. The receivers must also be very

sophisticated and must use low noise input circuits. These are at present only practicable for spot frequencies and to make sure of intercepting all possible signals they would have to be capable of sweeping through a band of about 5,000 Mc/s or more and at the same time of detecting signals in the narrow bandwidths of about 1,000 c.p.s. used for the transmission. To ensure that short transmissions were not undetected would require a multiplicity of receivers and recorders. Used intelligently Moon circuits should be able to provide adequate freedom from interception for highly classified messages.

(b) Jamming

To jam Moon communications is more difficult than to intercept transmissions. The communication transmitter will radiate about 5 kW's in a band only a few kilocycles wide and the jamming transmitter must radiate about the same power. Moreover, it must make allowance for the Doppler shift in frequency caused by the velocities of the transmitting and receiving stations relative to the Moon. The only practical way of overcoming this effect would be to radiate jamming power over a wider band, which would mean increasing the mean power of the jamming transmitter. It would obviously be impossible to jam the whole spectrum of several thousands of Mc/s and it would only be practicable to jam a few defined frequencies. A modest expenditure on alternative frequencies should ensure that vital and short communications would always get through.

12 COST

A world-wide teletype system using the Moon might consist of stations at the following places:

1	United Kingdom	7	Singapore
2	Ottawa	8	Gan
3	Christmas Island	9	Aden
4	Hong Kong	10	Nairobi
5	New Zealand	11	Cyprus
6	Australia	12	Bermuda

Each station initially would comprise:

	<u>Approx. Capital Cost</u>
1 aerial system about 60 ft diameter	£50,000
1 transmitter of 5 kW mean power	20,000
1 receiver	5,000
1 recorder and relay equipment	2,000
1 power plant	5,000
1 building works, etc.	20,000
Total	<u>£102,000</u>

Staff

1 Manager/Engineer
2 Technicians

Annual Costs

Salaries	£5,000
Amortisation (5% of Capital)	5,000
Depreciation	10,000
Operating Costs	5,000
Total	<u>£25,000</u>

The total cost of twelve stations would be about £1,200,000 and the annual operating costs about £300,000.

To this must be added development costs for prototype equipment, say another £500,000.

The above costs are based on operating the stations for a maximum of twelve hours per day. If and when twenty-four hour operation is introduced then some extra equipment and extra staff would be required.

13 CONCLUSIONS

A reliable and economical system of world wide teletype communication could be developed, based upon the reflection of radio signals from the Moon. The system would be able to provide about eight standard teletype channels for about 5 hours operation per day and would be a useful supplement to existing h.f. radio circuits.

When artificial passive satellites become available, as is expected in a few years, these can also be used and will enable the number of working hours per day to be increased, and transmission delays to the antipodes to be eliminated.

LIST OF REFERENCES

<u>Ref.No.</u>	<u>Author</u>	<u>Title, etc.</u>
1	Hey, J.S, Hughes, V.A.	J.I.E.E. January, 1961.
2	Victor, W.K, Stevens, R, Golomb, S.W.	J.P.L. Technical Report No.32 - 132. August 1961.
3	Hahn, P.H, Randall, N.C.	Availability of Moon for Global Communications I.R.E. Transactions. September 1961.

ATTACHED: Drgs. GW/P/10482 to 10484.

DISTRIBUTION:

Ministry of Aviation

CGWL		
DGEM		
DGGW	6	} 19 copies thr' GW (G&J) 5
WRE	6	
US Attaches	7	
DGLRD (TA)	4	
RRE	3	
SRDE	3	
TIL	10	

RAE

DD(E)	
Radio	2
Arm	
IAP	
Instn & Ranges	2
Aberporth	2
Patents	
Library	

Other Establishments

<i>to be seen</i> Seey DRFC (Min of Defence)	3
ASRE	2

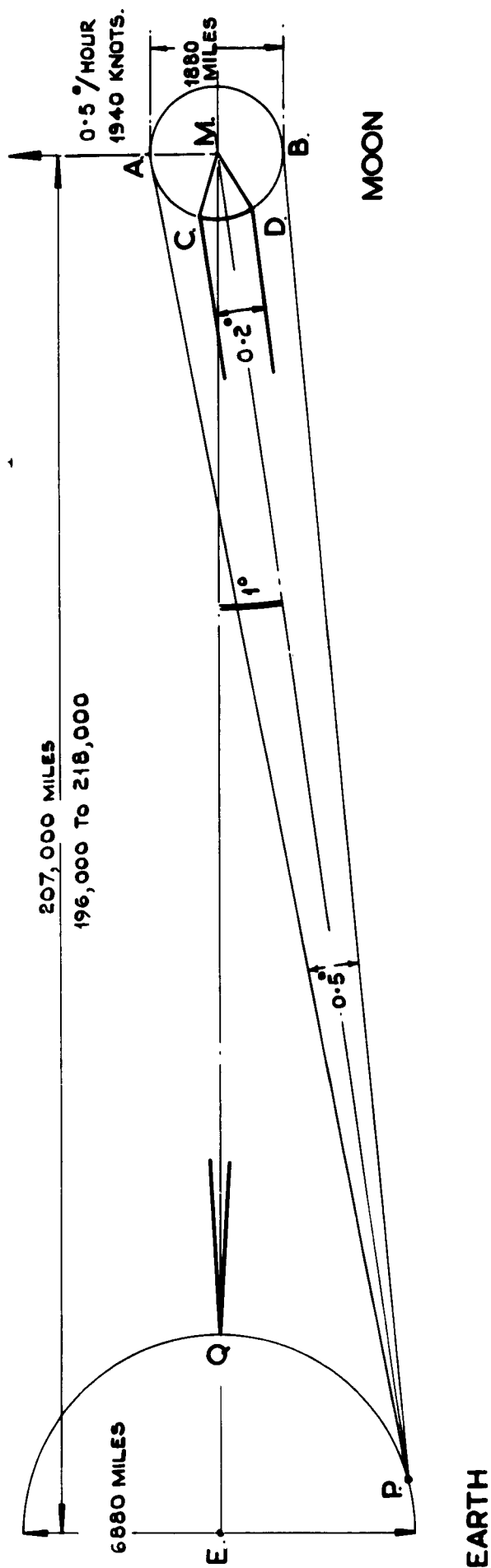

FIG. 1. EARTH - MOON GEOMETRY

MOON'S DISC VIEWED FROM EARTH.

FIG. 2.(a)

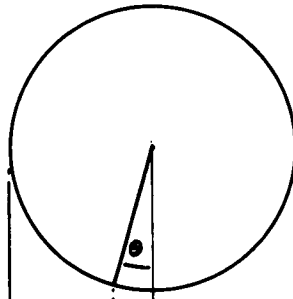

FIG. 2.(b)

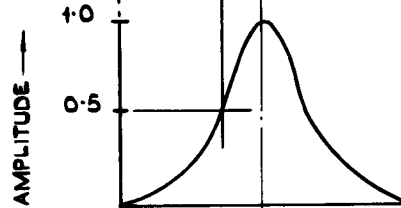

FIG. 2.(c)

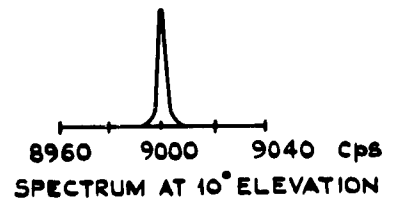
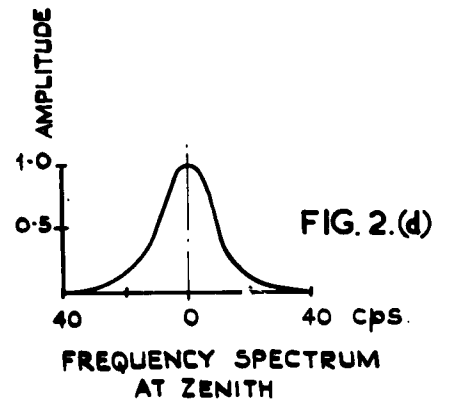
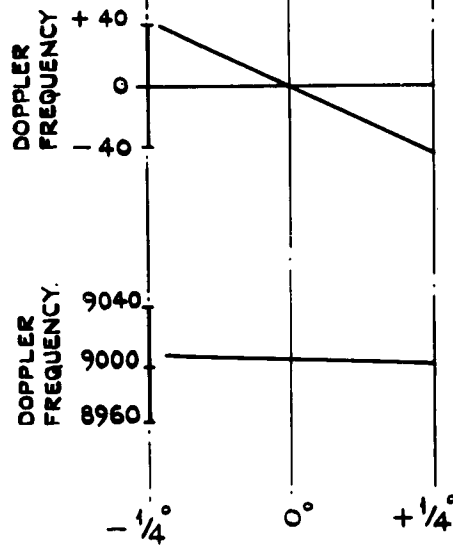

FIG. 2.(e)

FIG. 2. DOPPLER SHIFT DUE TO EARTH ROTATION

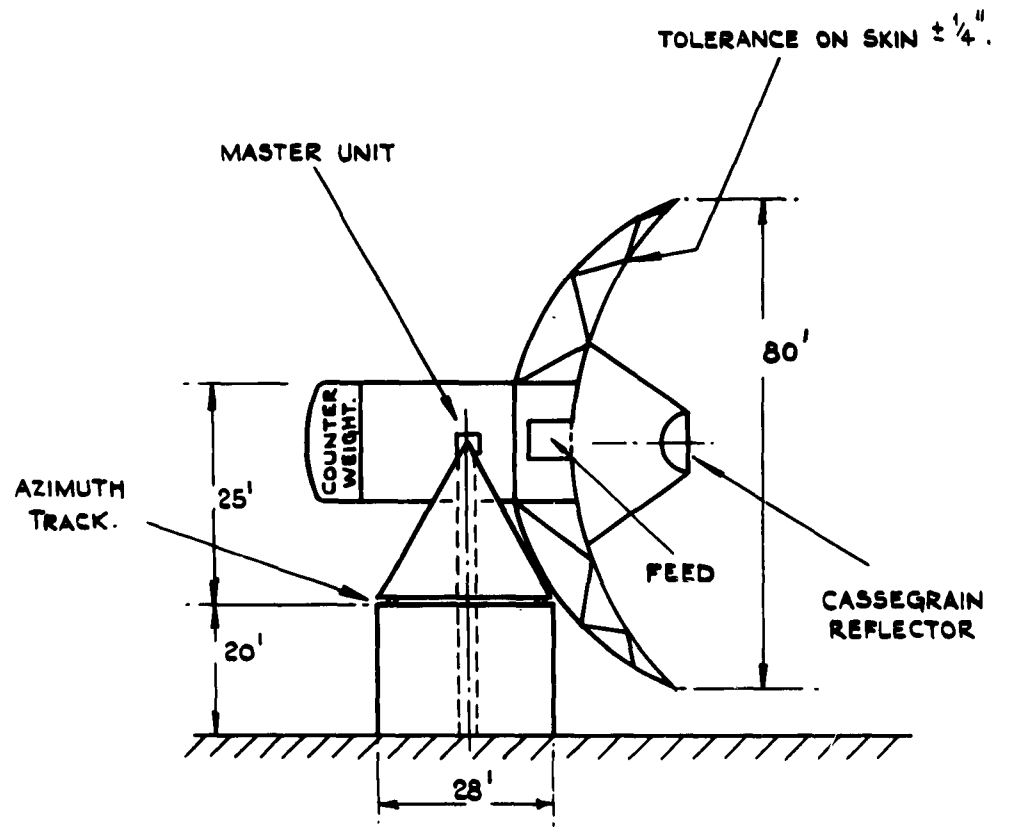

FIG.3. AERIAL OF MOON COMMUNICATION



*Information Centre
Knowledge Services*
[dstl] Porton Down,
Salisbury
Wiltshire
SP4 0JQ
22060-6218
Tel: 01980-613753
Fax 01980-613970

Defense Technical Information Center (DTIC)
8725 John J. Kingman Road, Suit 0944
Fort Belvoir, VA 22060-6218
U.S.A.

AD#: AD326790

Date of Search: 29 July 2008

Record Summary: AVIA 6/19001

Title: Note on the Use of the Moon and Passive Satellites for Long Distance
Communications

Availability Open Document, Open Description, Normal Closure before FOI Act: 30 years

Former reference (Department) TECH MEMO GW 402

Held by The National Archives, Kew

This document is now available at the National Archives, Kew, Surrey, United Kingdom.

DTIC has checked the National Archives Catalogue website (<http://www.nationalarchives.gov.uk>) and found the document is available and releasable to the public.

Access to UK public records is governed by statute, namely the Public Records Act, 1958, and the Public Records Act, 1967.

The document has been released under the 30 year rule.

(The vast majority of records selected for permanent preservation are made available to the public when they are 30 years old. This is commonly referred to as the 30 year rule and was established by the Public Records Act of 1967).

This document may be treated as UNLIMITED.