

UNCLASSIFIED

AD NUMBER	
AD336940	
CLASSIFICATION CHANGES	
TO:	unclassified
FROM:	confidential
LIMITATION CHANGES	
TO:	Approved for public release, distribution unlimited
FROM:	Distribution authorized to U.S. Gov't. agencies only; Administrative/Operational Use; 15 MAR 1963. Other requests shall be referred to Office of Naval Research, One Liberty Center, 875 North Randolph Street, Arlington, VA 22203-1995.
AUTHORITY	
31 Mar 1975, Group-4, DoDD 5200.10, per document marking; ONR ltr dtd 4 May 1977	

THIS PAGE IS UNCLASSIFIED

CONFIDENTIAL

AD 336 940

DEFENSE DOCUMENTATION CENTER

FOR

SCIENTIFIC AND TECHNICAL INFORMATION

CAMERON STATION, ALEXANDRIA, VIRGINIA



CONFIDENTIAL

NOTICE: When government or other drawings, specifications or other data are used for any purpose other than in connection with a definitely related government procurement operation, the U. S. Government thereby incurs no responsibility, nor any obligation whatsoever; and the fact that the Government may have formulated, furnished, or in any way supplied the said drawings, specifications, or other data is not to be regarded by implication or otherwise as in any manner licensing the holder or any other person or corporation, or conveying any rights or permission to manufacture, use or sell any patented invention that may in any way be related thereto.

NOTICE:

THIS DOCUMENT CONTAINS INFORMATION  
AFFECTING THE NATIONAL DEFENSE OF  
THE UNITED STATES WITHIN THE MEAN-  
ING OF THE ESPIONAGE LAWS, TITLE 18,  
U.S.C., SECTIONS 793 and 794. THE  
TRANSMISSION OR THE REVELATION OF  
ITS CONTENTS IN ANY MANNER TO AN  
UNAUTHORIZED PERSON IS PROHIBITED  
BY LAW.

336 940

Annual Report | March 15, 1962 to March 14, 1963

**RELATIONSHIP BETWEEN DECOMPOSITION KINETICS  
AND SENSITIVITY (U)**

*Prepared for:*

OFFICE OF NAVAL RESEARCH  
DEPARTMENT OF THE NAVY  
WASHINGTON 25, D.C.

ARPA ORDER NO. 301-62  
PROJECT CODE NO. 9100  
CONTRACT NO. Nonr-3760(00)

STANFORD RESEARCH INSTITUTE

MENLO PARK, CALIFORNIA

\*SRI

STANFORD RESEARCH INSTITUTE

MENLO PARK, CALIFORNIA



This document consists of <sup>67</sup>.....pages.

No. **23** of 210 copies, Series A

March 15, 1963

Annual Report | March 15, 1962 to March 14, 1963

## RELATIONSHIP BETWEEN DECOMPOSITION KINETICS AND SENSITIVITY (U)

Prepared for:

OFFICE OF NAVAL RESEARCH  
DEPARTMENT OF THE NAVY  
WASHINGTON 25, D.C.

ARPA ORDER NO. 301-62  
PROJECT CODE NO. 9100  
CONTRACT NO. Nonr-3760(00)

By: A. B. Amster M. E. Hill  
M. W. Evans T. Mill

SRI Project No. PRU-4051

CONTRACT PERIOD: 15 MARCH 1962 TO  
14 MARCH 1964

Reproduction in whole or in part is permitted for  
any purpose of the United States Government

Approved:

THOR L. SMITH, DIRECTOR  
PROPULSION SCIENCES DIVISION

**DOWNGRADED AT 3 YEAR INTERVALS**  
**DECLASSIFIED AFTER 12 YEARS**  
DOD DIR 5200.10

This document contains information affecting the national de-  
fense of the United States within the meaning of the Espionage  
Laws, Title 18, U. S. C., Sections 793 and 794. Its transmission  
or the revelation of its contents in any manner to an un-  
authorized person is prohibited by law.

**CONFIDENTIAL** SRI-3-734

# CONFIDENTIAL

## ABSTRACT

Stanford Research Institute, under the sponsorship of ARPA and Office of Naval Research, is studying two difluoroamino compounds in the following three situations.

- A. The detonation characteristics, including the shock sensitivity, of the liquid phase
- B. The adiabatic self-heating of the liquid phase
- C. The mechanism and kinetics of thermal decomposition of the liquid phase.

These approaches were chosen for their susceptibility to analysis in terms of basic physical and chemical parameters and because they are interrelated. Each study is being carried out on the isomers, 1,2-bis(difluoroamino)propane and 2,2-bis(difluoroamino)propane, in order to assess the importance of structural variation.

A. Detonation Characteristics. The objectives of this phase of the work are (1) to determine quantitatively some of the detonation characteristics of the two compounds, 1,2- and 2,2-bis(difluoroamino)propane, including the kinds of shock that will initiate the detonation, and (2) to study the relationship of shock sensitivity to the other detonation characteristics, to the physical properties, and to the chemical kinetics of thermal decomposition. Experimental work during the past year has included measurements of detonability, detonation velocity, and failure diameter of 1,2 and 2,2 DP. Both cylindrical and conical confinements were used for the experiments with the 1,2 DP and conical confinements for 2,2 DP. The conical confinement consisted of a combination of straight, thin-walled copper tube (long enough to obtain stable detonation) with tapering to about 1-cm diameter over the rest of the length.

The experiments establish that both 1,2 and 2,2 DP detonate at velocities of 5-7 mm/ $\mu$ sec and have failure diameters of less than 10 mm. Variations of detonation velocity from shot to shot and within one shot are greater than can be accounted for by the uncertainties in the measuring techniques. This variation is as yet unexplained.

The ideal Chapman-Jouguet values were calculated, using the B.K.W. equation of state and the Ruby Code method, for the reported density value of 1.256 g/cc; a later measurement in our laboratory gave 1.17 g/cc. The C-J velocity was 6.55 mm/ $\mu$ sec; the pressure was 192 Kbar; the temperature was 2828<sup>o</sup>K.

## CONFIDENTIAL

B. Adiabatic Self-Heating. If an explosive is placed in an environment, the temperature of which is continuously changed so as to follow precisely the rising temperature of the decomposing sample, then a modification of the Arrhenius rate equation for a first order reaction may be applied in its logarithmic form:

$$\ln\left(\frac{dt}{dt}\right) = \ln(qZ/c) - E/R(1/T)$$

Hence, given a temperature-time history from a single experiment and a value of the heat capacity, one may obtain values  $qZ$  and  $E$ . For a fluid requiring a confining vessel the mathematical treatment, though more complicated, is still tractable in terms of calculating  $E$  and, with certain assumptions,  $qZ$ .

Self-heating experiments of this type have been conducted on two liquid compounds: 1,2 DP and 2,2 DP. The results indicate that the thermal decomposition of 1,2 DP does not proceed as required by the mathematical model, giving an unrealistic energy of activation value. On the other hand the 2,2 DP appears to decompose in a simple fashion. The energy of activation calculated from three runs is  $\Delta E_a = 51.0 \pm 2.5$  kcal/mole. A value of  $qZ$  will be calculated when the additional required data are obtained.

C. Kinetics and Mechanism of Thermal Decomposition. The thermal decomposition of 1,2 DP has been examined in nitrobenzene solution over the range 176-187°. The initial rate was found to be invariant, within experimental error, over a fourfold change in concentration (0.52-0.14 M). After one quarter to one half-life, the rate markedly accelerates. The following rate laws were found to describe the reaction over much of the decomposition:

$$\begin{aligned} \text{Rate (176}^\circ) &= dx/dt = k_1(A-x) + 80k_1(A-x)x^2; k_1 = 1 \times 10^{-5} \text{ sec}^{-1} \\ \text{Rate (187}^\circ) &= dx/dt = k_1(A-x) + 64k_1(A-x)x^2; k_1 = 3 \times 10^{-5} \text{ sec}^{-1} \end{aligned}$$

Kinetic parameters for both the first-order portion and autocatalytic portion of the decomposition were estimated:

$$\begin{aligned} k_1 &= 3.7 \times 10^{14} \exp(-40.2 \pm 2/RT) \text{ sec}^{-1} \quad (E_a = \text{kcal/mole}) \\ k_3 &= 1.8 \times 10^{14} \exp(-35.7 \pm 2/RT) \text{ l}^2 \text{ mol}^{-2} \text{ sec}^{-1} \end{aligned}$$

The principal reaction product from long heating of 1,2 DP is a black, insoluble polymer of unknown structure. Several volatile intermediates have been detected in small amounts. Two of these intermediates are thought to be acetonitrile and 2-(N-fluoroimino)propionitrile. This same pattern of products is observed in the decomposition of both the pure liquid and nitrobenzene solutions.

The rate of decomposition of 1,2 DP in nitrobenzene is markedly increased by small amounts of 2,6-di-t-butyl-4-methylphenol, a free-radical chain inhibitor.  $\alpha$ -Methylstyrene also increases the rate of decomposition. Water catalyzes the decomposition, but does not appear to be responsible for the observed autocatalysis. Replacement of

## CONFIDENTIAL

nitrobenzene by hexadecane leads to a diminution in the rate of decomposition. Sodium butoxide in butanol destroys 1,2 DP rapidly at 25°; the volatile intermediates produced in this reaction are identical to those produced in the thermal decomposition.

Pronounced surface effects were found in the vapor-phase decomposition of 1,2 DP ( $10^{-3}$  M at 187°). The reaction is accelerated in steel vessels but retarded in glass vessels. In a new glass bulb the rate is about one-tenth the rate found in nitrobenzene solution. Products of the vapor-phase decomposition are identical with those found in the solution reaction; this suggests that the vapor-phase decomposition takes place at the surface.

We believe that the rate-controlling step in the thermal decomposition of 1,2 DP involves the loss of HF from the secondary carbon, followed by C-C bond cleavage and polymerization of the intermediates. Probably, the high molecular weight residue is responsible for the observed autocatalysis.

The vapor phase decomposition of 2,2 DP was examined at 200° in glass and steel bulbs at  $10^{-3}$  M concentration. The decomposition was found to be autocatalytic. Several intermediate products were detected but the final product is a dark, polymeric residue. The rate of decomposition is about one-tenth that of 1,2 DP. Probably the reaction occurs on the surface.

A brief examination of the decomposition of 2,2 DP in nitrobenzene indicates the rate here is also much slower than the rate for 1,2 DP.

# CONFIDENTIAL

## CONTENTS

ABSTRACT . . . . .	ii
LIST OF ILLUSTRATIONS . . . . .	vii
LIST OF TABLES . . . . .	ix
I INTRODUCTION . . . . .	1
II SHOCK SENSITIVITY . . . . .	4
A. Summary . . . . .	4
B. Background . . . . .	4
C. Experimental . . . . .	6
D. Theoretical . . . . .	13
E. Future Plans . . . . .	15
III ADIABATIC SELF-HEATING . . . . .	16
A. Summary . . . . .	16
B. Background . . . . .	16
C. Experimental . . . . .	18
1. Experimental Details . . . . .	18
2. Results . . . . .	22
D. Theoretical . . . . .	22
E. Future Plans . . . . .	31
IV KINETICS OF THERMAL DECOMPOSITION . . . . .	32
A. Summary . . . . .	32
B. Mechanism and Kinetics of the Thermal Decomposition of 1,2 DP . . . . .	33
1. Kinetics Studies . . . . .	33
2. Mechanism Studies . . . . .	38
3. Discussion . . . . .	42

# CONFIDENTIAL

## CONTENTS (Concluded)

C.	Kinetics of the Thermal Decomposition of 2,2 DP. . . . .	51
1.	Experimental. . . . .	51
2.	Results and Discussion. . . . .	51
D.	Future Plans . . . . .	53
	ACKNOWLEDGMENTS. . . . .	54
	APPENDIX--PREPARATION AND PROPERTIES OF 1,2- AND 2,2-BIS- (DIFLUOROAMINO)PROPANE . . . . .	55

# CONFIDENTIAL

## ILLUSTRATIONS

Fig. 1	Typical Oscilloscope Record of Continuous Wire Detonation Velocity Measurement (U) . . . . .	7
Fig. 2	Detonation Velocity Apparatus (I) (U) . . . . .	8
Fig. 3	Detonation Velocity Apparatus (II) (U) . . . . .	9
Fig. 4	Detonation Velocity Apparatus (III) (U) . . . . .	10
Fig. 5	Detonation Velocity Apparatus (III-Modified) (U) . . . . .	11
Fig. 6	Schematic Drawings of A (Type I) and B (Type II) Pressure Bomb Assemblies (U) . . . . .	20
Fig. 7	Thermocouple Connections Used in Pressure Bomb Assemblies (U) . . . . .	21
Fig. 8a	Typical Time-Temperature Record in Adiabatic Self-Heating Experiment (Record No. ASH 3-12) (U) . . . . .	23
Fig. 8b	Plot of $\ln dT/dt$ vs. $1/T$ (U) . . . . .	23
Fig. 9	Plots of $\ln dT/dt$ vs. $1/T$ for Adiabatic Self-Heating Experiments with 1,2 DP (U) . . . . .	24
Fig. 10	Plots of $\ln dT/dt$ vs. $1/T$ for Adiabatic Self-Heating Experiments with 2,2 DP (U) . . . . .	25
Fig. 11	Plots of $\ln (dT/dt)$ vs. $(1/T)$ for Consecutive Reactions (U) . . . . .	27
Fig. 12	Plots of Concentration vs. Temperature for Consecutive Reactions ( $\Delta E < 0$ ) (U) . . . . .	29
Fig. 13	Plots of Concentration vs. Temperature for Consecutive Reactions ( $\Delta E = 0$ ) (U) . . . . .	29
Fig. 14	Plots of Concentration vs. Temperature for Consecutive Reactions ( $\Delta E > 0$ ) (U) . . . . .	29
Fig. 15	Chromatogram of Decomposition Products of Nitrobenzene Solution of 1,2 DP Obtained on a 5-ft. Dinonyl-phthalate Column at 70°C and 30 ml/min Flow Rate (U) . . . . .	35

# CONFIDENTIAL

## ILLUSTRATIONS (Concluded)

Fig. 16	Molar Concentration of 1,2 DP vs. Time for Nitrobenzene Solution of 1,2 DP at 176°C (Aliquot Method)(U) . . . . .	36
Fig. 17	Molar Concentration of 1,2 DP vs. Time for Nitrobenzene Solution of 1,2 DP at 187°C (Tared Sample Method)(U) . . . . .	36
Fig. 18	First Order Plots for Thermal Decomposition of 1,2 DP in Dry (0.019 M water) and Wet (0.227 M water) Nitrobenzene Solutions(U) . . . . .	39
Fig. 19	Log-log Plot of $[R/k_1(A - x)] - 1 = nx^y$ for 0.416 M Solution of 1,2 DP in Nitrobenzene at 176°C (U) . . .	44
Fig. 20	Plots of Rate vs. Time for 0.46 M 1,2 DP in Nitrobenzene at 176°C--Experimental Data as shown in Table VI--Eq. (4.3) for $n = 80, y = 2$ (U) . . . . .	45
Fig. 21	Chromatogram of Decomposition Products of Nitrobenzene Solution of 2,2 DP Obtained on a 5-ft Dinonylphthalate Column at 76°C and 30 ml/min Flow Rate(U) .	52

# CONFIDENTIAL

## TABLES

Table I	Detonation Experiments. . . . .	12
Table II	Input Data and Results of Detonation Performance Calculation for 1,2 DP. . . . .	14
Table III	Results of Adiabatic Self-Heating Experiments . . .	26
Table IV	Decomposition of Pure Liquid 1,2 DP at 153°C. . . .	33
Table V	Vapor Phase Decomposition of 1,2 DP . . . . .	37
Table VI	Results of Kinetics Experiment with 0.461 M 1,2 DP in Nitrobenzene at 176°C . . . . .	43
Table VII	Kinetic Parameters for Thermal Decomposition of 1,2 DP in Nitrobenzene . . . . .	46
Table A-I	Physical Properties of 1,2-Bis(difluoroamino)- Propane . . . . .	57
Table A-II	Physical Properties of 2,2-Bis(difluoroamino)- Propane . . . . .	58

# CONFIDENTIAL

## I INTRODUCTION

The word sensitivity implies a quantitative measure of the ease of inducing in a material a rapid exothermic chemical decomposition accompanied by a pressure rise of sufficient magnitude to be destructive. Many empirical tests devised to measure sensitivity fail to correlate, are only partially satisfactory as predictive tests, and give little fundamental information. Moreover, the results of such tests are not interpretable in terms of basic physical and chemical behavior.

There are two reasons for this unsatisfactory state of affairs. First, many of the tests are so complicated that they cannot be reduced to the basic physics and chemistry of the system. From the results, one cannot analyze the physical events reliably enough to deduce the chemistry; nor does one know the chemistry well enough to be able to interpret the results in terms of the applied disturbance. Second, there are several different kinds of events the results of which can be termed explosive. For example, a given high energy liquid chemical, depending upon circumstances and upon its chemical and physical characteristics, may undergo one or more of the following kinds of exothermic reaction accompanied by a very fast pressure rise: a detonation wave in the liquid phase; thermal decomposition in the liquid phase uniformly throughout the mass; vaporization of the liquid, followed by a detonation wave in the gas phase; vaporization of the liquid, followed by thermal decomposition in the gas phase; vaporization of the liquid, followed by initiation of a deflagration wave in the gas phase, and then by ignition and deflagration in the liquid phase.

The reason for the lack of correlation of the empirical sensitivity tests may often be that the tests are concerned with different events in the lists above, i.e., different paths of decomposition. A card-gap test measures sensitivity to detonation of the liquid phase. A drop-weight or impact test may reflect, at least in part, the ease of thermal decomposition of the liquid phase. The hot-wire test may measure the

## CONFIDENTIAL

ease with which the liquid vaporizes and ignites in the gas phase. Thermal stability measurements may reflect liquid phase decomposition kinetics.

Clearly, it is desirable to define precisely the event during any sensitivity measurement. In order to predict with assurance the kind of explosive behavior to be expected of a material under a given set of circumstances, one should know:

1. Thermal stability in terms of liquid phase decomposition kinetics
2. Detonability of liquid phase, i.e., whether it will support a detonation wave, and the failure diameter for detonation
3. The necessary conditions for initiating a detonation wave in the liquid phase
4. The deflagrability of the liquid phase, i.e., the conditions of pressure and geometry, if any, under which the liquid supports a deflagration wave at its surface.
5. The necessary conditions for initiating a deflagration wave at the liquid surface
6. The decomposition kinetics of the vapor phase
7. Detonability of the vapor phase
8. The necessary conditions for initiating a detonation wave in the vapor phase
9. The deflagrability of the vapor phase
10. The necessary conditions for initiating a deflagration wave in the vapor phase.

A common need for understanding each of the ten decomposition paths is knowledge of the decomposition chemical kinetics. In this work our aim is to study the decomposition kinetics and their relationship to one specific sensitivity situation which can be relatively clearly defined, namely, the shock sensitivity. We expect the information on decomposition kinetics to be useful in understanding and predicting sensitivity in other experimental situations as well.

CONFIDENTIAL

## CONFIDENTIAL

We have undertaken the study for several liquid materials of related chemical structure, hydrocarbons containing two difluoroamino ( $\text{NF}_2$ ) groups. The compounds being studied initially are two isomers, 1,2-bis(difluoroamino)propane and 2,2-bis(difluoroamino)propane. These two compounds are hereafter referred to as 1,2 DP and 2,2 DP, respectively. The program is divided into three interrelated parts. They are

- (a) The shock sensitivity to detonation of the liquid phase
- (b) The adiabatic self-heating of the liquid phase
- (c) The mechanism and kinetics of thermal decomposition

In (a) the detonation characteristics, particularly the shock sensitivity to detonation, are measured. The results will be analyzed in terms of detonation theory, taking into account the physical properties of the liquid and the chemical kinetics of the liquid phase decomposition. Adiabatic self-heating, (b), is a method for obtaining values for the pre-exponential factor and the activation energy of the liquid phase decomposition if the over-all reaction rate can be formally treated as a simple first-order rate process. The simple form of the rate equation thus obtained makes it attractive for use in theories of detonation, critical size for ignition, thermal explosion, and impact sensitivity. Part (c), in addition to providing rate data for various theories of sensitivity, will provide information assisting in an understanding of the relationship between chemical structure and sensitivity.

# CONFIDENTIAL

## II SHOCK SENSITIVITY (Marjorie W. Evans and A. B. Amster)

### A. Summary

The objectives of this phase of the work are to determine quantitatively some of the detonation characteristics of 1,2 and 2,2 DP, including the shock sensitivity to detonation, and to study the relationship of shock sensitivity to the other detonation characteristics, to the physical properties, and to the chemical kinetics of thermal decomposition.

Experimental work during the past year has included measurements of detonability, detonation velocity, and failure diameter of 1,2 DP and 2,2 DP. Theoretical work has included a calculation of the ideal Chapman-Jouguet detonation velocity, pressure and temperature of 1,2 DP, using a method which has been reasonably successful in calculating these quantities in CHNOF systems. In addition, the equations describing detonation characteristics of homogeneous condensed materials in terms of their chemical and physical properties<sup>1</sup> have been programmed and solutions are being obtained for a range of parameters.

### B. Background

Shock sensitivity is determined by measuring the characteristics of a minimum initiating shock which is moving into the explosive from an inert attenuating material. The sense in which "minimum" is used requires definition. The shock variables of pressure, density, and material velocity in the general case are space- and time-dependent. For convenience in treatment it is helpful to simplify the shock or to limit the space-time region which is said to influence the initiation of detonation, or to do both. As an example of the first, one can specify plane shocks of square profile and define shock sensitivity in terms of

---

<sup>1</sup>Marjorie W. Evans, J. Chem. Phys. 36, 193 (1962)

CONFIDENTIAL

## CONFIDENTIAL

magnitude and duration of initiating shock. As an example of the second, one can make the assumption that in cylindrical charges the controlling events occur on the axis, where the shock front is perpendicular to the axis and the shock pressure is a maximum; then one can substitute for the planar shock the more easily created curved shock, and measure the shock characteristics on the axis. With the approximation that the shock is square, the shock pressure on the axis at the initiating boundary of the explosive rises rapidly to a value which remains constant for a duration  $\tau$ , at which time a rarefaction wave from side or rear abruptly reduces the pressure to the ambient value. For this latter situation the minimum shock sensitivity is conveniently defined, for shocks of given duration, in terms of the minimum pressure,  $p$ , required for initiation. Given the correctness of the assumption and the appropriateness of the approximation, measurements of the shock sensitivity by the two systems, plane square shock and curved shock, will be in accord. It seems clear that shock sensitivity must be defined as a function of the two variables magnitude and duration. When the duration of a shock is limited by the diameter of the receiver rather than the physical dimension of the booster explosive, it follows that the minimum magnitude of shock for initiation will depend, for a cylindrical charge, on its diameter. Thus, if shock sensitivity is in such a case defined as magnitude of shock, one expects it to vary with diameter.

Relations connecting the detonation characteristics (including shock sensitivity) and the physical and chemical characteristics have been worked out for laminar detonation of homogeneous condensed materials having thermal decomposition rates expressible as a single first-order rate process.<sup>1</sup> The situation in that case is simplified by two circumstances. First, the form of the rate law dictates, in a shock of given magnitude and duration, that chemical reaction occurs either essentially completely or essentially not at all. Second, the mechanism of initiation of chemical reaction at the front of a formed detonation wave is the same as the mechanism of initiation of chemical reaction in a shock, i.e., each occurs by shock compression to a temperature sufficiently high that reaction takes place before a rarefaction wave intervenes. The simplicity

CONFIDENTIAL

# CONFIDENTIAL

of the system makes possible the statement of a set of algebraic equations which not only yield the dependence of shock sensitivity on diameter, but also relate this in an internally consistent model to failure diameter, induction time, and the relationship between diameter and steady detonation velocity.

Before measuring the shock sensitivity of a given material, one must establish its detonability, which is the ability of a material to support a steady detonation wave. It is a function of diameter, the minimum diameter for which a material is detonable being the failure diameter. Experimental work during this year has been directed toward studying the detonability of 1,2 and 2,2 DP. It is necessary to establish detonability with sufficiently long charges that unequivocal demonstration is made of either the formation of a steady detonation wave, or the failure of a transient reaction wave.

## C. Experimental

Three methods were used for determining detonability and detonation velocity: ionization probes,<sup>2,3,4</sup> pressure probes,<sup>5</sup> and a continuous wire sensor<sup>6</sup> (the latter may be referred to as CRISP--continuous recording of instantaneous shock properties). In one method of using the continuous wire sensor, a fine high resistance wire is placed in the cylindrical charge, parallel to the long axis. The charge is enclosed in a metal case. A voltage from a constant current source is applied at the end of the wire opposite the end at which the detonation is initiated. The ionization in the moving detonation wave completes the circuit from the wire to the case. Since the voltage drop along the wire is directly proportional to the resistance of the wire remaining in the circuit, it is also proportional to the length of undetonated charge. Thus from a measure of the voltage drop and its change with time one can calculate the detonation velocity as a function both of time and of position of

<sup>2</sup>Frank C. Gibson, Rev. Sci. Instr. 25, 226 (1954)

<sup>3</sup>H. T. Knight and R. E. Duff, Rev. Sci. Instr. 26, 257 (1955)

<sup>4</sup>A. W. Campbell, M. E. Malin, T. J. Boyd, Jr., and J. A. Hull, Rev. Sci. Instr. 27, 567 (1956).

<sup>5</sup>A. B. Amster and R. L. Beauregard, Rev. Sci. Instr. 30, 942 (1959)

<sup>6</sup>A. B. Amster, P. A. Kendall, L. J. Veillette, and Burton Harrell, Rev. Sci. Instr. 31, 188 (1960)

## CONFIDENTIAL

the detonation front. A typical record of voltage drop versus time, as displayed on a cathode ray oscilloscope, is shown in Fig. 1. The oscilloscope is triggered at time A, and the wave reaches the wire at time B. The line CD records the changing voltage drop as the wave moves parallel to the wire. If the detonation velocity is constant, CD is straight. When detonation ceases, the voltage drops to E. Lines I and II are independently recorded to provide time and voltage calibrations.

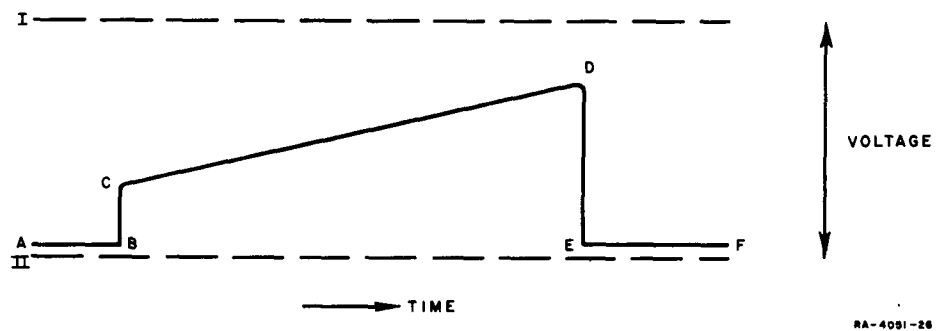

FIG. 1 TYPICAL OSCILLOSCOPE RECORD OF CONTINUOUS WIRE  
DETONATION VELOCITY MEASUREMENT

The 1,2 and 2,2 DP were prepared immediately before the detonation tests by distillation from the solvent (see the Appendix). Chromatographic analyses showed that the material was 99.4% pure or better. Three tests each were performed on 1,2 and 2,2 DP.

Four experimental arrangements were used, as shown in Figs. 2, 3, 4, and 5. The cylindrical arrangement of Fig. 2 corresponds to the card-gap test recommended by the JANAF Panel on Liquid Propellant Test Methods except for the presence of ionization probes and the absence of a witness plate. The cylindrical arrangement of Fig. 3 incorporated the simultaneous use of ionization probes, pressure probes, and the continuous wire sensor. In the arrangements of Figs. 4 and 5 the cylindrical section provides a length in which detonation can achieve a steady velocity; failure diameter, if it is greater than the minimum diameter of the cone, will be determined by the position of the failure in the conic section.

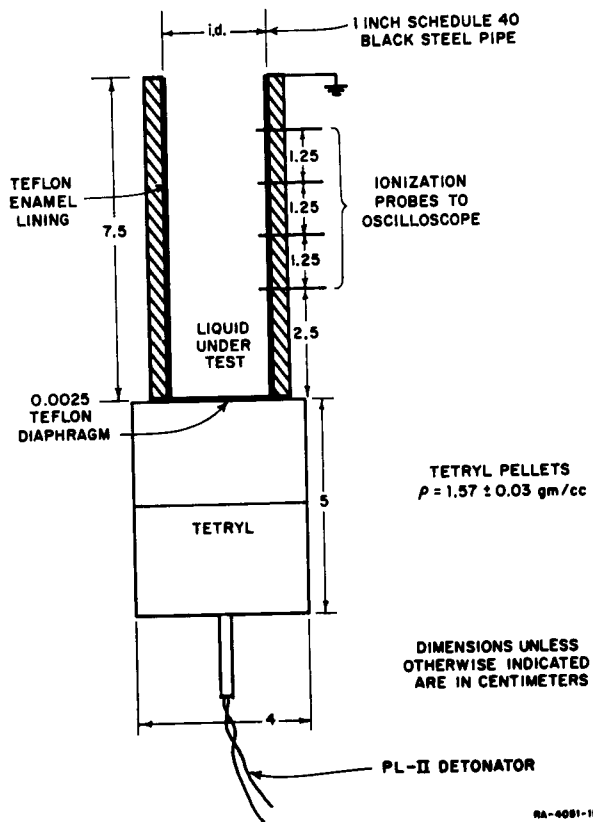
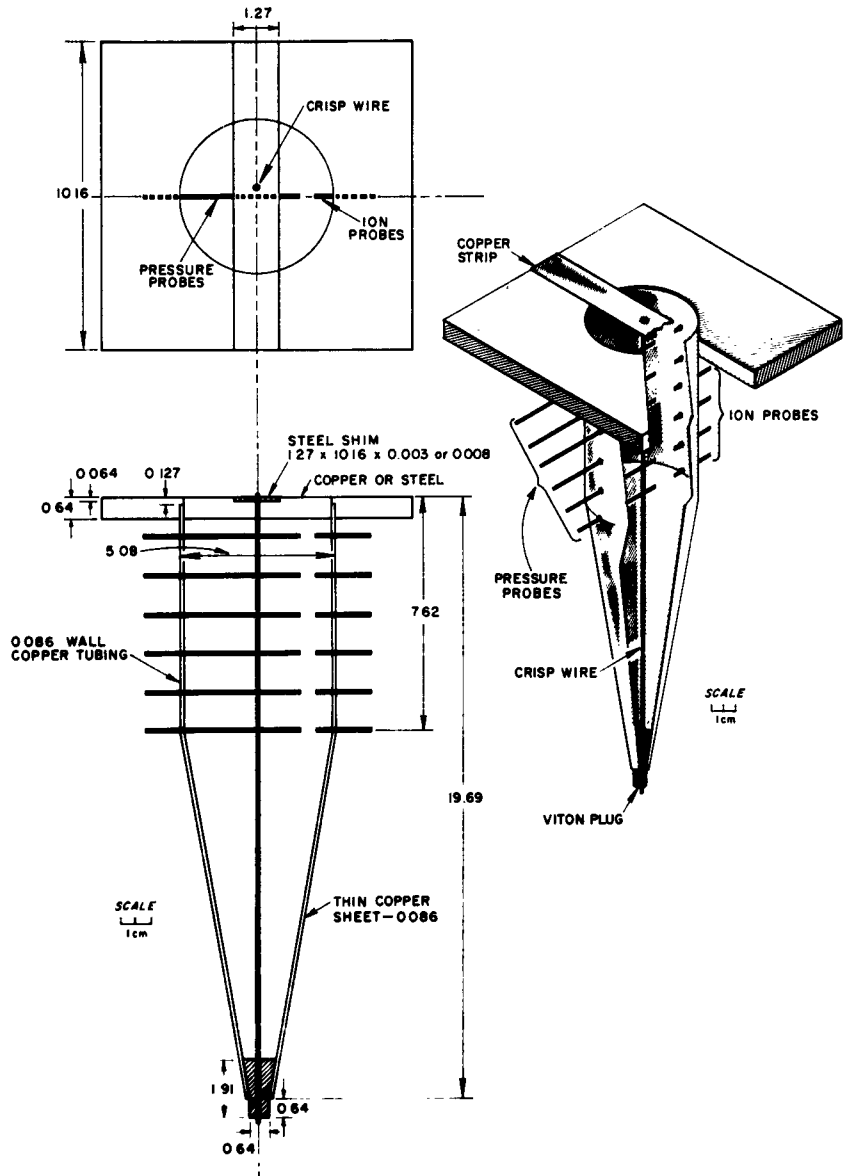

FIG. 2 DETONATION VELOCITY APPARATUS (I)





RB-4091-28

FIG. 4 DETONATION VELOCITY APPARATUS (III)

# CONFIDENTIAL

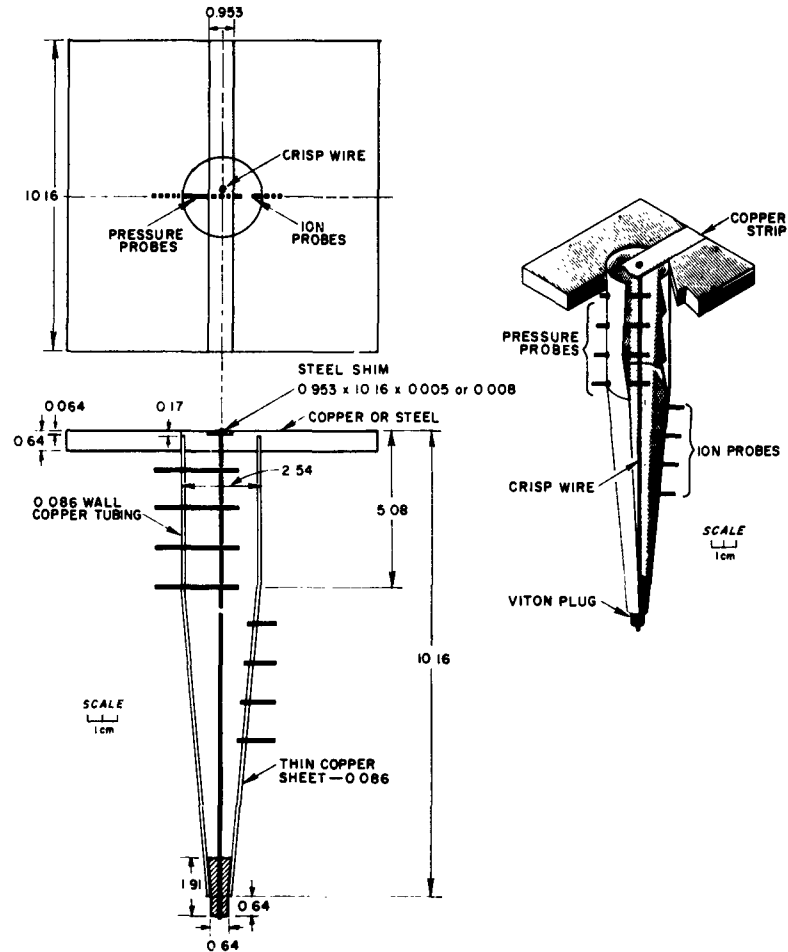

RB-4051-27

FIG. 5 DETONATION VELOCITY APPARATUS (III-Modified)

One test with the 1,2 DP was carried out in each of three experimental arrangements. All three tests with the 2,2 DP were in the arrangement of Fig. 5. The observed failure diameters and the detonation wave velocities as a function of distance from the attenuator-acceptor interface are given in Table I. Both distances and failure diameters are calculated from and must reflect the precision of the velocities. The experiments establish that 1,2 and 2,2 DP detonate at velocities of 5-7 mm/ $\mu$ sec, and have failure diameters of less than 10 mm. The variations of velocity

Table I  
**DETONATION EXPERIMENTS**

Compound	Experimental Arrangement	Detonation Velocity (mm/μsec)			Failure Diameter (mm)	Record No.
		Ion Gauge	Pressure Gauges	CRISP		
1	1, 2 DP	Fig. 2	No record	Omitted	--	DET-3
2		Fig. 3	7.2 over 80-180 mm	Failed	7.3 over 0-66 mm; 4.6 over 66-180 mm	DET-19
3		Fig. 4	Omitted	Omitted	6.6 ± 0.5 over 0-93 mm; 5.4 ± 0.4 over 93-186 mm	DET-23
4	2, 2 DP	Fig. 5	Failed	Failed	5.86 over 25-125 mm	DET-20
5			7.27 over 63-102 mm	Failed	7.3 over 0-137 mm	DET-21
6			6.0 over 76-102 mm	5.3 over 12-25 mm 5.9 over 25-51 mm	5.8 ± 0.6 over 0-153 mm	< 9

# CONFIDENTIAL

from shot to shot and within one shot are greater than can be accounted for by the uncertainties in the measuring techniques. We cannot for the present explain the discrepancy.

## D. Theoretical

The ideal Chapman-Jouguet detonation characteristics were calculated for 1,2 DP using a method which has been reasonably successful in calculating detonation characteristics of CHNOF systems.\* It is based on the Kistiakowsky-Wilson equation of state, as modified by Cowan and Fickett<sup>7</sup> and generalized by Mader.<sup>8</sup> The Brinkley method is used for computing the equilibrium composition, and the generalized technique is referred to as the BKW calculation. The calculation was made using the Ruby Code.<sup>9</sup> It permits computing the equilibrium composition of the explosion products the detonation Hugoniot, the values of the hydrodynamic and thermodynamic variables at the C-J point, and the isentrope of the reaction products. Table II, which gives input data and results, reports the calculated equilibrium composition of products and the values of the C-J pressure, temperature, and detonation velocity.

The covolumes of the products and the constants in the equation of state were those suggested by Mader.<sup>8</sup> The required reference-state thermodynamic functions and enthalpies of formation were taken from the JANAF Interim Chemical Tables.<sup>10</sup> The calculation was performed neglecting CH<sub>4</sub> in the product gas. It is not expected that the values of the C-J

---

\*The calculations were made by personnel of the Chemistry Division at Lawrence Radiation Laboratory, Livermore, California. We are particularly indebted to Dr. Edward Lee for his help.

<sup>7</sup>R. D. Cowan and W. Fickett, J. Chem. Phys. 24, 932 (1956)

<sup>8</sup>C. R. Mader, Los Alamos Scientific Laboratory Report LA-2613, Oct. 9, 1961, "Detonation Performance Calculations Using the Kistiakowsky-Wilson Equation of State."

<sup>9</sup>H. B. Levine and Robert E. Sharples, Lawrence Radiation Laboratory Report UCRL-6815, March 20, 1962, "Operator's Manual for Ruby."

<sup>10</sup>JANAF Interim Chemical Tables, The Dow Chemical Company, Midland, Michigan.

# CONFIDENTIAL

Table II  
INPUT DATA AND RESULTS OF DETONATION PERFORMANCE  
CALCULATION FOR 1,2 DP

Formula	$C_3H_6F_4N_2$			
Mol Wt	146.09			
Density (g/cc)	1.256*			
$\Delta H_f^\circ$ (kcal/mole HE)	-40.1**			
$T_o$ ( $^\circ K$ )	298			
C-J Gas Volume (cc/mole product gas)	17.7			
Moles Product Gas/gram reactant	0.0253			
Moles Solid Carbon/gram reactant	0.0156			
Gamma	1.808			
No. Moles Product Gas/gram reactant				
	$H_2$	0.00029	NF	0.0
	$NH_3$	0.01086	$CF_4$	0.00489
	$N_2$	0.00142	HF	0.00784
Calculated C-J values				
	C-J Pressure (kbar)			192
	C-J Temperature ( $^\circ K$ )			2828
	Detonation Velocity (mm/ $\mu$ sec)			6.55

\*First Quarterly Progress Report on Advanced Test Methods for Determining Operational Characteristics of Propellants, Document No 61-21-16 Contract AF 04(611)-7413, Air Reduction Company

\*\*Reported at the July 1962 JANAF Thermochemical Panel.

pressure, temperature, and detonation velocity will be greatly affected if it is taken into account. The value of gamma is low, possibly as a result of the relatively low value for moles of product gas per gram of reactant. The C-J pressure and temperature are in the range expected. Since these calculations were made a measurement of density in our laboratories gave a value of 1.18 g/cc at 25 $^\circ C$  rather than 1.256. Detonation calculations based on this lower value of density can be expected to give lower values of detonation velocity (about 6 mm/ $\mu$ sec) and of pressure.

# CONFIDENTIAL

# CONFIDENTIAL

The equations<sup>1</sup> describing characteristics of two-dimensional laminar detonation waves in homogeneous condensed materials have been programmed, and their solutions are being obtained for a range of parameters which include those expected to be appropriate for the difluoroamino compounds.

## E. Future Plans

The detonation velocities of 1,2 and 2,2 DP and of nitromethane will be studied further in an attempt to establish the significance of the two levels of detonation velocity reported in Table I. Observational techniques will include the use of a streak camera in addition to those already employed. Nitromethane will be included in the program as a check compound, since its detonation properties are reasonably well established.<sup>11</sup> Measurements of shock sensitivity will be made. The detonation velocities and shock sensitivities of IBA, 1,3- and 1,1-bis(difluoroamino)propanes will be studied as they become available and can be worked into the schedule.

The computations based on the theoretical equations will be carried out over a range of parameters believed to be suitable. As experimental data on physical and chemical properties and on detonability and sensitivity become available, the theoretically predicted detonation characteristics will be compared with observations, with a view to establishing the usefulness of the theory and to improving it.

---

<sup>11</sup>A. W. Campbell, M. E. Malin, and T. E. Holland, *J. Appl. Phys.* **27**, 963 (1956).

<sup>12</sup>A. W. Campbell, W. C. Davis, and J. R. Travis, *Phys. Fluids* **4**, 498 (1961)

<sup>13</sup>J. R. Travis, A. W. Campbell, W. C. Davis, and J. B. Ramsay, "Shock Initiation of Explosives III. Liquid Explosives," *Les Ondes de Detonation*, Coll. Inter. Centre Nat. Rech. Scien., 1962, p. 45

<sup>14</sup>G. Nahmani and Y. Manheimer, *J. Chem. Phys.* **24**, 1074 (1956).

# CONFIDENTIAL

## III ADIABATIC SELF-HEATING (A. B. Amster)

### A. Summary

The adiabatic self-heating method<sup>15</sup> for determining activation energy and pre-exponential factor of condensed phase thermal decomposition was applied to 1,2 and 2,2 DP. Results with the 1,2 DP were inconsistent, and yielded unreasonably high values of activation energy. Results with the 2,2 DP were quite reproducible and gave a value of 51.0 ± 2.5 kcal/mole for the activation energy.

### B. Background

Consider a finite quantity of material at temperature T, in an environment of some other temperature T<sup>i</sup>. If the material decomposes according to a simple zero-order process, its temperature is given by the following equation:

$$\lambda \nabla^2 T + \rho c \left( \frac{\partial T}{\partial t} \right) = Z e^{-E_a/RT} \quad (3-1)$$

and further, if the mechanism is first order, Z = ρQv and

$$-\lambda \nabla^2 T + \rho c \left( \frac{\partial T}{\partial t} \right) = \rho q v e^{-E_a/RT} \quad (3-2)$$

where

- t = time (sec)
- λ = thermal conductivity (cal deg<sup>-1</sup>cm<sup>-1</sup>sec<sup>-1</sup>)
- ρ = density (g cm<sup>-3</sup>)
- c = specific heat (cal<sup>-1</sup> g<sup>-1</sup> deg<sup>-1</sup>)
- T = temperature (°K)
- q = heat of decomposition (cal g<sup>-1</sup>)
- v = frequency factor (sec<sup>-1</sup>)
- E<sub>a</sub> = activation energy (cal M<sup>-1</sup>)
- R = gas constant (1.987 cal M<sup>-1</sup> deg<sup>-1</sup>)
- Z = heat generation coefficient (cal cm<sup>-3</sup> sec<sup>-1</sup>)

---

<sup>15</sup>D. Gross and A. B. Amster, Eighth Symposium (International) on Combustion, Williams and Wilkins Company, Baltimore, 1962, pp. 728-734.

## CONFIDENTIAL

In the particular case in which the environmental temperature is continuously changed so as to follow precisely the rising temperature of the decomposing sample,  $\nabla^2 T = 0$  and

$$c \frac{dT}{dt} = qv e^{-E_a/RT} \quad (3-3)$$

or

$$\ln \frac{dT}{dt} = \ln \frac{qv}{c} - \frac{E_a}{RT} \quad (3-4)$$

Hence, given a temperature-time history from a single experiment and a value of the heat capacity, one may obtain values for  $qv$  and  $E_a$ . For non-first-order reactions, the evaluation of  $qv$  is slightly more involved but can still be accomplished; the interpretation of  $E_a$  is unambiguous. The case of simultaneous reactions is considered in section D below.

When the sample material is a liquid the experimental arrangement is somewhat more complicated than with solids, and the above analysis must be modified. To prevent evaporation, the sample is confined within a metal vessel capable of withstanding the vapor pressure of the liquid at elevated temperatures. The confining vessel is now heated partially by the heat generated by the liquid decomposition and partially by the furnace, and the analysis becomes:

Let

$m_L$  = mass of liquid (g)

$m_M$  = mass of fraction of container heated by liquid (g)

The heat generation rate of the liquid,  $dQ/dt$  cal/sec, is

$$\frac{dQ}{dt} = m_L qv e^{-E_a/RT} \quad (3-5)$$

If there is no temperature gradient within the liquid or the containing vessel or between them, the rate of increase in heat content for the liquid and that part of the container heated by the liquid is:

$$\frac{dH}{dt} = (m_M c_M + m_L c_L) \frac{dT}{dt} \quad (3-6)$$

## CONFIDENTIAL

Equating Eqs. (3-5) and (3-6) and taking natural logarithms gives

$$\ln \frac{dT}{dt} = \ln \frac{m_L qv}{m_M c_M + m_L c_L} - \frac{E_a}{RT} \quad (3-7)$$

Thus, a plot of  $\ln(dT/dt)$  vs.  $1/T$  should give a straight line with slope  $-E/R$  and with intercept

$$\ln \frac{m_L qv}{m_M c_M + m_L c_L} \quad (3-8)$$

where  $c_M$ ,  $c_L$ , and  $m_L$  are known or can be evaluated independently. An evaluation of  $m_M$  therefore permits determination of  $qv$ .

An approximate value for  $m_M$  can be obtained as follows: Assume that the boundary between the regions in the metal vessel heated by the liquid and the oven lies halfway between the outer and inner surfaces of the approximately spherical vessel. If  $r_1$  is the radius of the cavity and  $r_2$  the outer radius of the vessel, then the mass of metal heated by the liquid is

$$\frac{4}{3} \pi \rho_m \left( \frac{r_2 + r_1}{2} \right)^3 - r_1^3 = m_M \quad (3-9)$$

where  $\rho_m$  is the density of the metal vessel. This value can then be substituted in expression (3-8) and  $qv$  calculated, since the other parameters are known. From experiments with bombs of differing thicknesses the reliability of this approximation can be tested. If the model is suitable, extrapolation of these intercepts to zero thickness will give

$$\ln \frac{m_L qv}{m_M c_M + m_L c_L} = \ln \frac{qv}{c_L} \text{ for } m_M = 0 \quad (3-10)$$

### C. Experimental

#### 1. Experimental Details

The equipment consisted of (a) pressure bomb assembly, (b) oven, and (c) automatic control and temperature recording equipment. The sample was contained within the bomb, which was placed within the air oven. The temperature of the sample and the difference between it and the oven

## CONFIDENTIAL

were measured with a thermocouple system. The oven temperature was brought slowly to a value at which self-heating was detected, after which automatic control minimized the temperature difference. Data were recorded until the experiment terminated when the sample deflagrated or exploded.

Bombs of two types were used; schematic drawings of these are shown in Fig. 6a (Type I) and 6b (Type II). The construction material was nickel, chosen because of the possible corrosive properties of the difluoroamino propanes. The Type I bomb utilized the three-thermocouple arrangement of Fig. 7a, and the two couples in the bomb were retained by modified 1/16-in. i.d. Swagelok male connectors (not shown) welded in place. The lower and upper bomb casings were welded after the bomb plug was in place. The improved Type II utilized the two-thermocouple arrangement of Fig. 7b, and the couple in the bomb was welded to the lid. Type II is an improvement because of its greater simplicity, decreased mass, and more nearly spherically symmetric geometry.

The thermocouples were manufactured by Continental Sensing, Inc., Melrose Park, Delaware. The first used were chromel-alumel in stainless steel jackets. Although they were satisfactory, copper-constantan in Inconel jackets were later used for improved sensitivity. The leads for temperature measurement were brought to a Leeds and Northrup Speedomax H Azar (adjustable zero, adjustable range) recorder used in conjunction with an ice bath. Temperatures were measured to better than  $0.1^{\circ}\text{K}$ . The leads for differential measurement and control were connected to a Leeds and Northrup Model 9835 stabilized d-c microvolt amplifier. The amplified voltage was recorded and used for proportional control of the nichrome heater. For this purpose a Leeds and Northrup Series 60 C.A.T. system was used to control the output of a magnetic amplifier. Except during periods of very rapid temperature change, temperature differences were detected to  $0.01^{\circ}\text{K}$  and controlled to better than  $0.1^{\circ}\text{K}$ .

The pressure bomb assembly was hung, by the plug extension of the thermocouple, from a Transite plate, equipped on its upper surface with a spirally wound nichrome wire heater and a centrifugal blower. Holes

## CONFIDENTIAL

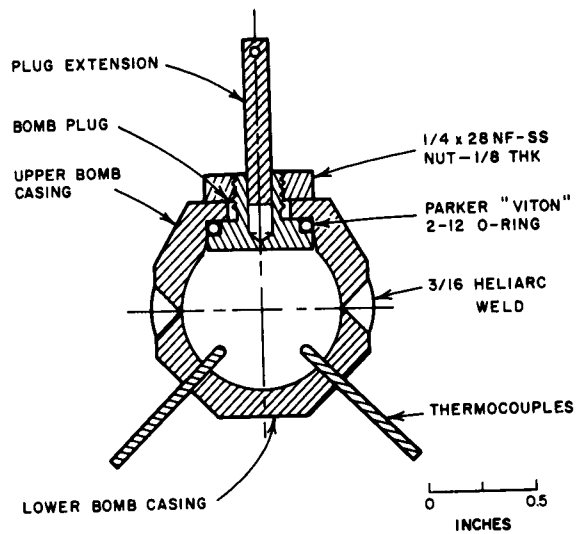

(a) TYPE I

RB-4051-2R

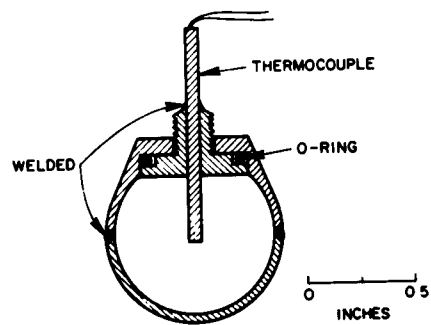

MATERIAL: COLD DRAWN NICKEL  
FINISH: MACHINE

(b) TYPE II

RB-4051-11R

FIG. 6 SCHEMATIC DRAWINGS OF A (Type I) AND B (Type II) PRESSURE BOMB ASSEMBLIES

# CONFIDENTIAL

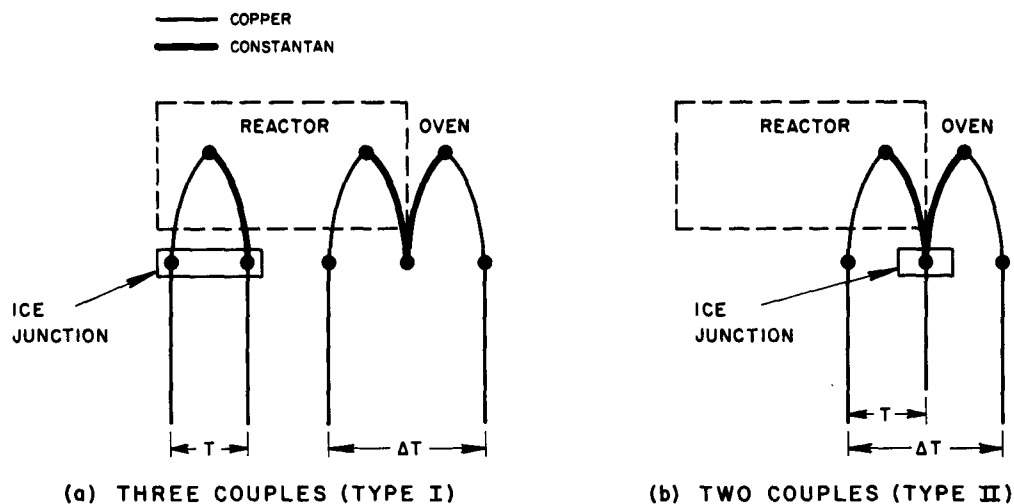

A-4051-13R

FIG. 7 THERMOCOUPLE CONNECTIONS USED IN PRESSURE BOMB ASSEMBLIES

were drilled through the plate at an angle so that air passing through the blower could pass over the heater to the bomb without the necessity of a path for direct radiation between heater and bomb. In addition to the couple or couples within the bomb, an additional couple was placed just outside of, but not in contact with the bomb (see Fig. 7). The assembly was set into a Dewar flask for which the Transite plate formed a snug-fitting lid, with the bomb at the center of the flask, which was 9 inches in diameter and 10 inches long. The flask was packed in vermiculite contained in a heavy-walled steel pipe. Addition of the liquid and all subsequent operations were performed remotely for safety.

The experiment was carried out as follows: The bomb was cleaned thoroughly by washing successively in  $\text{CH}_2\text{Cl}_2$ ,  $\text{HNO}_3$ , and  $\text{H}_2\text{O}$ . The liquid sample was added to about 80% of the bomb capacity, in order to allow for thermal expansion of the liquid; this amounted to 2.1 ml of liquid at room temperature. After assembly, heating under manual control over a period of time,  $t_{\text{SH}}$ , of about 5 hours brought the sample very slowly to a temperature,  $T_1$ , at which there was barely detectable self-heating. At that point automatic control of the temperature difference and recording of the temperature was instituted and continued until the experiment terminated.

# CONFIDENTIAL

## 2. Results

Six runs were made with 1,2 DP, and three with 2,2 DP. Figure 8 shows typical time-temperature behavior, the data being that of run ASH 3-12; the figure also shows the plot of  $1/T$  versus  $\ln dT/dt$ . Figure 9 shows  $1/T$  versus  $\ln dT/dt$  for four runs with 1,2 DP; the data for run ASH 13-12 resembled the other runs and is not reproduced. Figure 10 shows data for the three runs with 2,2 DP. Results are summarized in Table III.

Table III shows that the results with 1,2 DP are not reproducible and yield extremely high values for the activation energy. An apparent two-step behavior occurred in four of the six runs. It is shown in the next section that results of this type could result from an autocatalytic reaction in which a reaction with low activation energy occurs after development of sufficient catalyst concentration. However, the occurrence of surface reactions or complicated simultaneous reactions would invalidate Eqs. (3-1) and (3-2) and consequently the analysis. Because of the unreasonably high values of activation energy we conclude that the thermal decomposition is not simple, and that this method is not useful for determining  $E_a$ . Unless a new approach or analysis becomes apparent, no further experiments of this type will be made with 1,2 DP.

In contrast, 2,2 DP behaved in accordance with expectations based on the assumption of the validity of the method, giving an average value  $E_a = 51.0 \pm 2.5$  kcal/mole. Two of the runs were made in Type II spherical bombs. If the approximation of Eq. (3-9) is valid, and  $qv$  can be calculated from the intercept, Eq. (3-8), giving  $\log qv = 22.1 \pm 0.7$ .

### D. Theoretical\*

Suppose two reactions proceed consecutively without loss of heat to the surroundings:



\*This section contributed by C. M. Ablow, Manager of Mathematical Sciences Department.

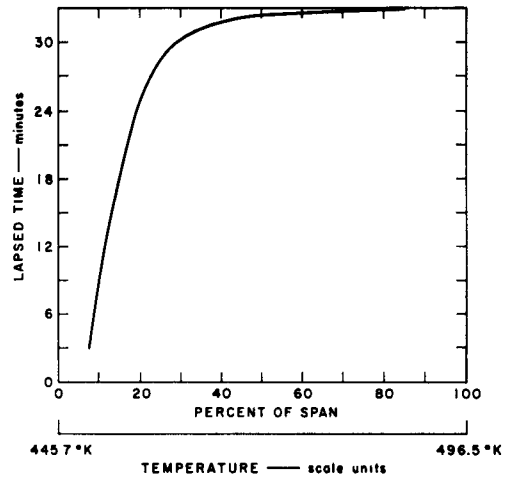

(a) TYPICAL TIME-TEMPERATURE RECORD IN ADIABATIC SELF-HEATING EXPERIMENT (RECORD NUMBER ASH 3-12).

RC-4051-3R

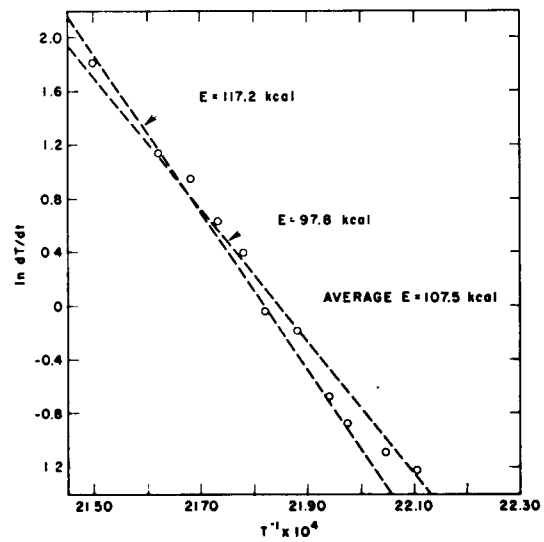

(b) PLOT OF  $\ln dT/dt$  vs.  $1/T$

RC-4051-4R

FIG. 8 (a) TYPICAL TIME-TEMPERATURE RECORD IN ADIABATIC SELF-HEATING EXPERIMENT (Record No. ASH 3-12)  
(b) PLOT OF  $\ln dT/dt$  vs.  $1/T$

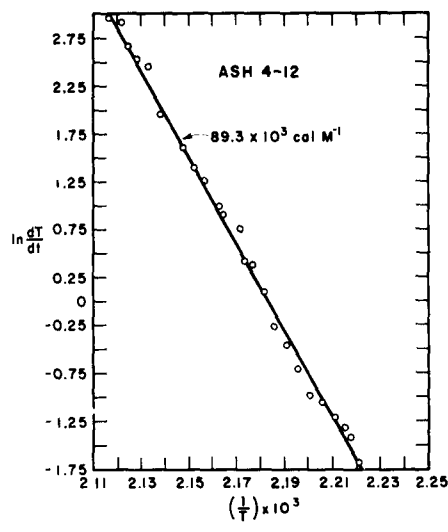

NO-4051-10R

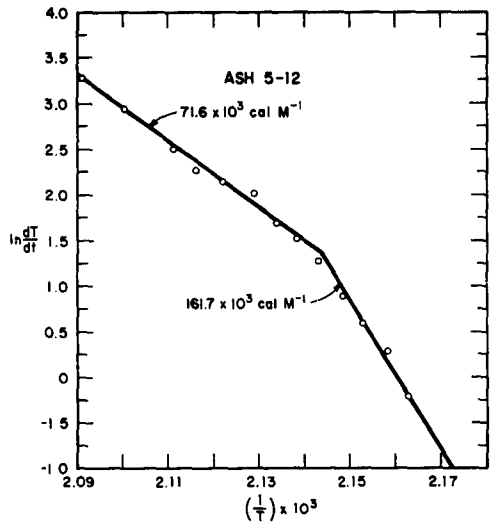

NO-4051-8R

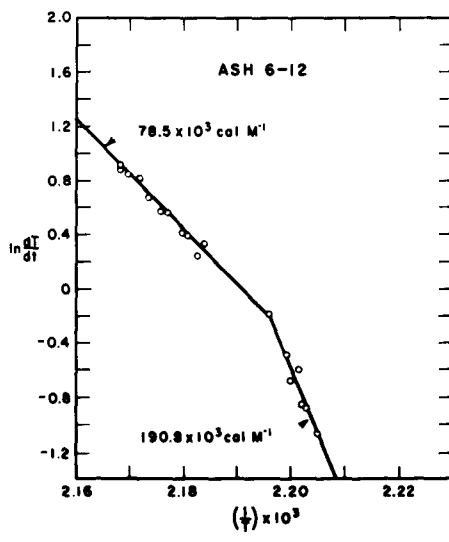

NO-4051-5R

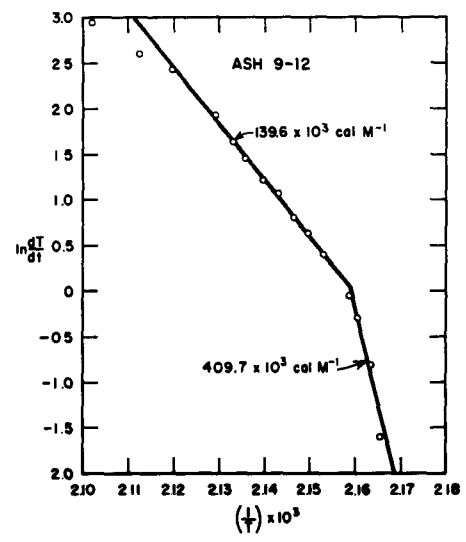

NO-4051-7R

FIG. 9 PLOTS OF  $\ln dT/dt$  vs.  $1/T$  FOR ADIABATIC SELF-HEATING EXPERIMENTS WITH 1,2 DP

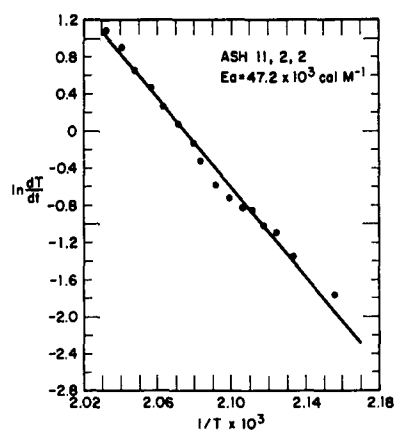

(a)

RD-4051-2C

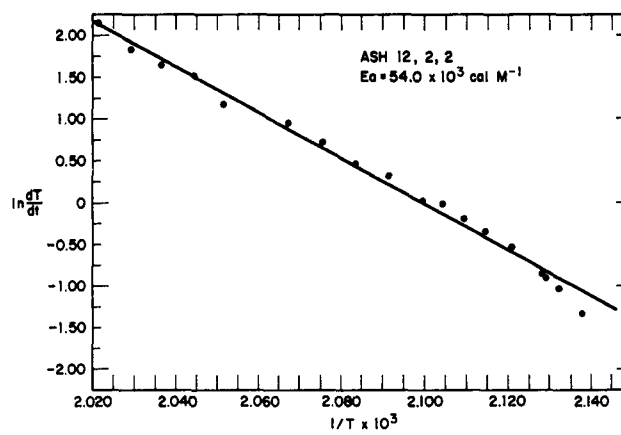

(b)

RD-4051-19

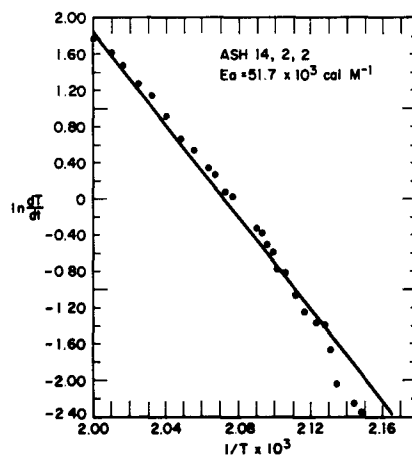

(c)

RD-4051-21

FIG. 10 PLOTS OF  $\ln \frac{dT}{dt}$  vs.  $1/T$  FOR ADIABATIC SELF-HEATING EXPERIMENTS WITH 2,2 DP

**CONFIDENTIAL**

Table III  
RESULTS OF ADIABATIC SELF-HEATING EXPERIMENTS

	Compound	Bomb		Duration of Manual Control t <sub>SH</sub> (hr)	Temp. at Beginning of Automatic Control T <sub>I</sub> (°C)	E <sub>a</sub> kcal/mole	Temp. Range (°C)	qv cal/g <sup>-1</sup> /sec <sup>-1</sup>	Record No.
		Type	Wall Thickness (cm)						
1	1,2 DP			5	170	107	179-192		ASH 3-12
2		I	0.470	5	170	89	178-199		ASH 4-12
3				5	185	{ 162 72 }	{ 188-195 195-204 }		ASH 5-12
4		I	0.147	-	177	{ 191 79 }	{ 179-182 182-189 }		ASH 6-12
5				6	169	{ 410 140 }	{ 189-191 191-199 }		ASH 9-12
6		II	0.107	6	203	{ 412 73 }	{ 192-195 195-208 }		ASH 13-12
7	2,2 DP	I	0.147	4-1/2	184	47.2	190-225		ASH 11-22
8		II	0.107	6-1/4	199	54.0	194-220	6.3 x 10 <sup>22</sup>	ASH 12-22
9				5-1/2	191	51.7	196-227	2.9 x 10 <sup>21</sup>	ASH 14-22

**CONFIDENTIAL**

## CONFIDENTIAL

It is shown in the following paragraphs that graphs of  $\ln(dT/dt)$  vs.  $(1/T)$  have the qualitative forms sketched in Fig. 11, where  $E_1$  and  $E_2$  are the activation energies of the two reactions.

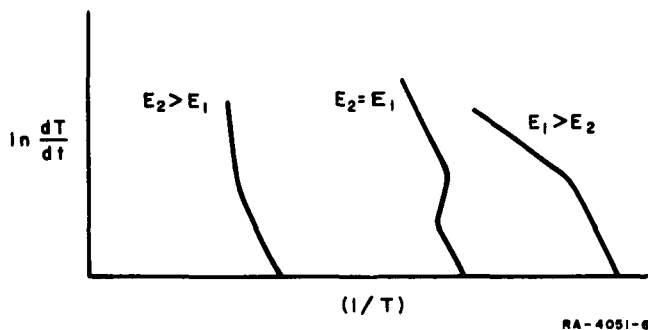

FIG. 11 PLOTS OF  $\ln dT/dt$  vs.  $1/T$  FOR CONSECUTIVE REACTIONS

Equations for the heat and mass balance are

$$c \frac{dT}{dt} = q_1 v_1 e^{-E_1/RT} + q_2 v_2 [L] e^{-E_2/RT} \quad (\text{heat}) \quad (3-12)$$

$$\frac{d[L]}{dt} = v_1 e^{-E_1/RT} - v_2 [L] e^{-E_2/RT} \quad (\text{mass}) \quad (3-13)$$

where  $[L]$  is the concentration of reactant  $L$ , and subscripts 1 and 2 indicate the reactions of Eqs. (3-11-1) and (3-11-2) respectively.

From Eqs. (3-12) and (3-13) one may derive the differential equation valid in the  $(T, [L])$  phase plane:

$$\frac{d[L]}{dT} = c \frac{v_1 e^{-E_1/RT} - v_2 [L] e^{-E_2/RT}}{q_1 v_1 e^{-E_1/RT} + q_2 v_2 [L] e^{-E_2/RT}} \quad (3-14)$$

or

$$\frac{d[L]}{dT} = p \frac{v e^{-\Delta E/RT} - [L]}{q v e^{-\Delta E/RT} + [L]} \quad (3-15)$$

## CONFIDENTIAL

where

$$\Delta E = E_1 - E_2,$$

$$q = q_1/q_2,$$

$$v = v_1/v_2,$$

and  $p = c/q_2.$

Equation (3-15) gives the slope of the graph of  $[L]$  vs.  $T$  at any point in the  $([L], T)$ -plane. In particular the curves connecting points at which that slope is constant may be plotted. If  $N$  is the numerator of the right hand side of Eq. (3-15)

$$N = p \{ v e^{-\Delta E/RT} - [L] \} \quad (3-16)$$

then the curve  $N = 0$  connects points with zero slope. Similarly if  $D$  is the denominator

$$D = q v e^{-\Delta E/RT} + [L] \quad (3-17)$$

then the curve  $D = 0$  connects points with infinite slope. The whole set of solutions of  $[L]$  vs.  $T$  for various initial conditions may now be plotted. The times corresponding to points on a particular  $([L], T)$  solution curve are obtained by integrating the mass balance Eq. (3-13).

Three cases are to be distinguished,  $\Delta E < 0$ ,  $\Delta E = 0$ , and  $\Delta E > 0$ . These cases are shown graphically in Figs. 12, 13 and 14.

Case I:  $\Delta E < 0$ . The solution curve is similar to BCFG in Fig. 12. At time zero, point B, the temperature is low and the concentration of  $L$  is zero. As time goes on the temperature and concentration  $[L]$  both rise along BC. The concentration rises to a maximum at F and then falls a little toward G as the temperature continues to rise.

The time rate of temperature rise can be found from the heat balance Eq. (3-12):

$$\frac{dT}{dt} = \frac{p}{v_2} e^{-E_2/RT} \{ q v e^{-\Delta E/RT} + [L] \} \quad (3-18)$$

or

$$\frac{dT}{dt} = \frac{p}{v_2} e^{-E_2/RT} D \quad (3-19)$$

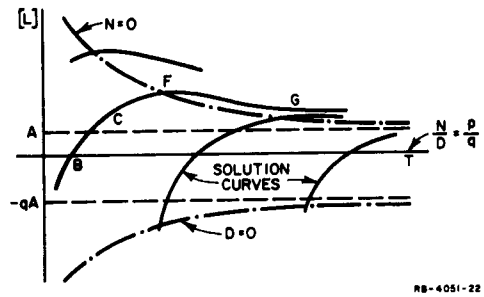

FIG. 12 PLOTS OF CONCENTRATION vs. TEMPERATURE FOR CONSECUTIVE REACTIONS ( $\Delta E < 0$ )

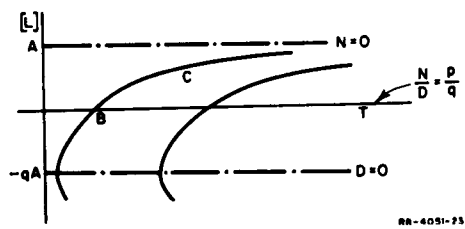

FIG. 13 PLOTS OF CONCENTRATION vs. TEMPERATURE FOR CONSECUTIVE REACTIONS ( $\Delta E = 0$ )

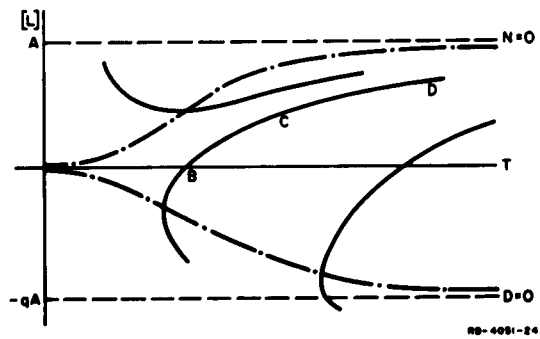

FIG. 14 PLOTS OF CONCENTRATION vs. TEMPERATURE FOR CONSECUTIVE REACTIONS ( $\Delta E > 0$ )

## CONFIDENTIAL

Near time zero,  $[L]$  is near zero and the temperature is low. Both these properties tend to make the exponential term in the braces, Eq. (3-18), dominate the concentration  $[L]$ . In approximation, then, near time zero

$$\frac{dT}{dt} = \frac{pqv}{v_2} e^{-E_1/RT}. \quad (3-20)$$

The bracket term is  $D$  of Eq. (3-17). Curves of constant  $D$  are parallel in the sketch to the curve  $D = 0$  shown. Thus at later times, along  $FG$  in the sketch,  $D$  is approximately constant. At late times Eq. (3-19), with  $D$  constant is a good approximation.

In summary, a plot of  $\ln(dT/dt)$  vs.  $(1/T)$  would have slope near  $(-E_1/R)$  at early times and near  $(-E_2/R)$  for late times in this case where  $E_2 > E_1$ .

Case II:  $\Delta E = 0$ . Both  $[L]$  and  $T$  continually rise during the reaction. The temperature rises without limit while the concentration of reactant  $L$  rises toward an upper bound. Equation (3-18) shows that near time zero, while  $[L]$  is much smaller than  $qv$ , Eq. (3-19) with  $D$  constant is a fair approximation. At late times Fig. 13 shows that  $[L]$  becomes nearly constant so that again Eq. (3-19) is approximately correct with  $D$  a larger constant.

In this case, a plot of  $\ln(dT/dt)$  vs.  $(1/T)$  has slope  $(-E_1/R)$  both for early and late times, with an intermediate region of transition at greater slope from the lower of two parallel lines to the upper.

Case III:  $\Delta E > 0$ . Near time zero,  $[L]$  in the bracket in Eq. (3-18) is negligible and Eq. (3-20) is valid. At late times Fig. 14 shows that the two terms of the bracket approach constants so that Eq. (3-19) with  $D$  constant is an approximate solution. In this case the slope of a plot of  $\ln(dT/dt)$  vs.  $(1/T)$  drops with time from  $(-E_1/R)$  to  $(-E_2/R)$ .

# CONFIDENTIAL

## E. Future Plans

Additional experiments will be carried out with 2,2 DP in pressure bombs with thinner walls in order to demonstrate the validity of Eq. (3-10) and to develop a better model for calculating reliable values of  $E_a$  and  $q_v$ .

Should these experiments confirm the value of the self-heating method, studies will be initiated on additional compounds.

# CONFIDENTIAL

## IV KINETICS OF THERMAL DECOMPOSITION (Theodore Mill)

### A. Summary

The objective of this phase is to acquire a knowledge of the nature and rate of the rate-controlling step in decompositions, and of the nature of intermediates, of transition states, and of the ultimate products in order to devise a description of the mechanism of the reaction.

Kinetic and mechanism experiments were carried out with 1,2 DP as a neat liquid, as a dilute solution in nitrobenzene, and in the vapor phase. A few experiments were carried out on the decomposition of 2,2 DP in the vapor phase. The two compounds apparently differ but little in their kinetic behavior, but have significantly different rates.

The decomposition of 1,2 DP in nitrobenzene solution in the temperature range 176-187°C is described by the equation

$$\text{rate} = dx/dt = k_1(A - x) + k_2(A - x)(x)^2$$

where  $(A - x)$  is the instantaneous concentration of 1,2 DP. Thus the reaction is autocatalytic over 60-70% of the decomposition. Kinetic parameters for the solution decomposition are

$$k_1 = 3.7 \times 10^{14} \exp[(-40.2 \pm 2)/RT] \text{ sec}^{-1}$$
$$k_2 = 1.8 \times 10^{14} \exp[(-35.7 \pm 2)/RT] \text{ liter}^2\text{mol}^{-2}\text{sec}^{-1}$$

where the units of  $E_a$  are kcal/mole. The vapor phase decomposition displays marked surface effects in glass and steel and is also autocatalytic.

2,2 DP decomposes at about one-tenth the rate of 1,2 DP. The decomposition displays autocatalysis both in solution and in the vapor phase; there are marked surface effects in the vapor phase.

# CONFIDENTIAL

## B. Mechanism and Kinetics of the Thermal Decomposition of 1,2 DP

### 1. Kinetics Studies

#### a. Decomposition of Pure Liquid

1,2 DP containing 1 to 2 percent methylene chloride, was stored on a vacuum line in small tubes inside polyurethane "totes." Twenty to thirty mg samples were frozen into tared capillary tubes on the vacuum line. The tubes were sealed with a flame and immersed for varying intervals of time in a bath at 153°C. Contents of each capillary were analyzed by gas chromatography. Several volatile products were found, but none was present in an amount equal to the loss of 1,2 DP. On long heating, the only product was a dark nonvolatile residue. The results of these experiments are given in Table IV. The first half-life is about 20 hours and the rate markedly accelerates thereafter. Since the polymeric residue separates from the starting material at an early stage (12-20 hr), the actual concentration of 1,2 DP may not change appreciably, although the total amount present does change.

Table IV  
DECOMPOSITION OF PURE LIQUID 1,2 DP AT 153°C

Tube No.	Time (min)	Initial Weight (mg)	Recovered Reactant (mg)	Percent Decomposition	Residue (mg)
1	1260	34.7	22.9	34	--
2	1440	33.7	12.7	62	4.6
3	1860	30.0	2.5	94	7.3
4	2535	21.6	0.05	99+	22.1

There are a number of experimental difficulties associated with a kinetic study of the pure liquid. The low boiling point (81°C) and the low rate of decomposition require the use of high temperature, and of pressures in excess of seven atmospheres, to provide conveniently fast rates of decomposition; thus container and sampling problems are difficult.

## CONFIDENTIAL

Furthermore, the uncertainty associated with the concentration of the neat liquid during decomposition and the invariance of the initial concentration place limitations on the possible kinds of kinetic experiments. We therefore decided to examine the decomposition in dilute solution, in the expectation of returning later to the problem of neat liquid decomposition by direct experimentation and by extrapolation of the solution study results.

### b. Decomposition of Solution in Nitrobenzene

Nitrobenzene was chosen as the solvent for the solutions studies because of its high boiling point ( $211^{\circ}\text{C}$ ), inertness, good solvent properties, and ease of purification. 1,2 DP in nitrobenzene in concentrations between 0.7 and 0.1 molar was found to decompose at a convenient rate for study in the temperature range  $175\text{--}190^{\circ}\text{C}$ . Samples were vacuum distilled into tared vessels containing known amounts of vacuum-distilled nitrobenzene. The gross features of the reaction were the same as those observed in the decomposition of the neat liquid. A polymeric phase separated during the decomposition; the same intermediates formed and disappeared, and the rate of decomposition accelerated after about one quarter-life. A gas chromatogram of a partially decomposed solution is shown in Fig. 15.

Rate measurements were made in two ways. For both methods a standard solution of 1,2 DP in nitrobenzene was used to standardize the samples. Reproducibility of the standard was about 2 percent from run to run during one day. In the first method, 10  $\mu$ liter samples of solution were withdrawn from 1.5 ml of bulk solution in glass through a serum cap and Teflon-glass stopcock. Aliquots were injected directly into the gas chromatograph and the amounts of 1,2 DP were estimated by comparison with the chromatogram of a standard sample. These data were often not reproducible, because of evaporative loss of the 1,2 DP through the stopcock and septum. This loss was demonstrated by following the change in concentration of pure n-octane dissolved in nitrobenzene. Results of several

**CONFIDENTIAL**

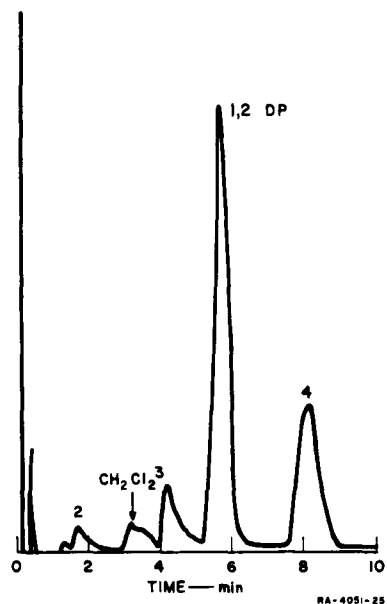

FIG. 15 CHROMATOGRAM OF DECOMPOSITION PRODUCTS OF NITROBENZENE SOLUTION OF 1,2 DP OBTAINED ON A 5-FT DINONYLPHTHALATE COLUMN AT 70°C AND 30 ml/min FLOW RATE

runs, made at 176°C under conditions for which no loss of octane was noted, are given in Fig. 16.

The second method involved the preparation of a number of sealed glass tubes, each containing 50  $\mu$ liter of solution. Pairs of tubes were removed from the temperature bath at selected time intervals and the contents analyzed by gas chromatograph. Initial values for duplicate samples agreed closely but divergence in results increased markedly as the reaction rate accelerated. Results of runs made at 187°C are given in Fig. 17.

**CONFIDENTIAL**

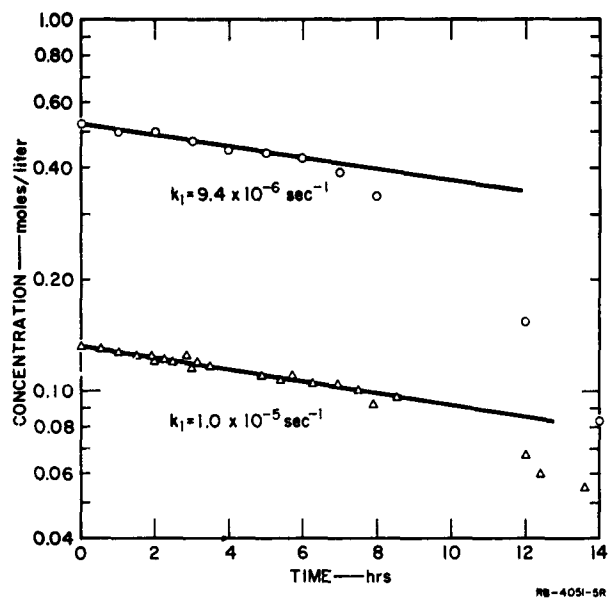

FIG. 16 MOLAR CONCENTRATION OF 1,2 DP vs. TIME FOR NITROBENZENE SOLUTION OF 1,2 DP AT 176°C (Aliquot Method)

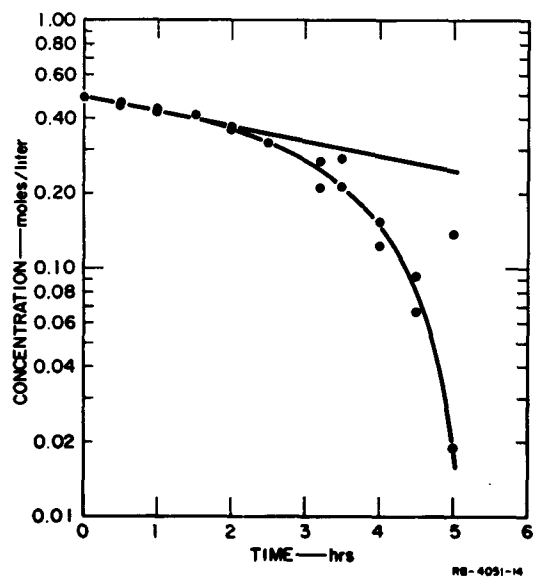

FIG. 17 MOLAR CONCENTRATION OF 1,2 DP vs. TIME FOR NITROBENZENE SOLUTION OF 1,2 DP AT 187°C (Tared Sample Method)

# CONFIDENTIAL

## c. Decomposition of Vapor

Experiments were carried out in calibrated 50-ml glass and steel bulbs. Known amounts of 1,2 DP were added to each bulb by freezing into the bulb quantities of material from a measured pressure of the vapor in a vacuum manifold of known volume. Bulbs were removed from the oil bath at intervals, the contents frozen in liquid nitrogen, and noncondensables estimated by pressure rise on the vacuum line. Samples of the noncondensable products were analyzed by mass spectrometry; only trace amounts of H<sub>2</sub> and N<sub>2</sub> were found. Condensables were transferred on the line into nitrobenzene and analyzed by gas chromatography.

The volatile products were identical to those observed in liquid phase and solution decompositions; there was a significant increase in the amount of peak 2 of Fig. 15. A brown polymer was deposited on the walls of the bulbs. The vapor phase decomposition rate was about one-tenth that of the nitrobenzene solution. There was a marked surface effect, which prevented obtention of reproducible results either in glass or steel. The surface effect takes the form of an increase in decomposition rate in used steel and a retardation in used glass. Probably the reaction takes place on the walls. Table V gives approximate half-lives.

Table V  
VAPOR PHASE DECOMPOSITION OF 1,2 DP

T (°C)	Concentration x 10 <sup>3</sup> (mole/l)	Container	t <sub>1/2</sub> (hrs)
177	0.64	New glass	~ 80
177	0.64	Used glass <sup>a</sup>	>> 80
187	0.64	Used glass <sup>b</sup>	~ 55
187	1.1	Used stainless steel	< 20

<sup>a</sup> Bulbs were used for one previous run at 177°C

<sup>b</sup> Bulbs were used for two previous runs at 176°C.

# CONFIDENTIAL

## 2. Mechanism Studies

### a. Catalysis by Water

Added water was found to cause a marked increase in decomposition rate of the pure liquid at 153°C but no quantitative data were obtained. The product was a dark polymer.

The effect of water on the rate of decomposition of 1,2 DP in nitrobenzene solutions was studied at 176°C. One solution studied was 0.227 M with respect to water and 0.655 M in 1,2 DP; the other was 0.019 M in water and 0.576 M in 1,2 DP. This latter small and uncertain amount of water was present originally in the 1,2 DP as obtained from the distillation. Rate measurements were made using sealed tubes with duplicate samples for each point, with the results shown in Fig. 18. There is a marked increase in rate for the "wet" (0.227 M) solution compared to that for the "dry" (0.019 M) solution. The apparent first-order rate constant for the wet solution decomposition was estimated to be  $4 \times 10^{-5} \text{ sec}^{-1}$ , which is more than three times the rate for the runs reported in Fig. 16. The apparent first order rate constant for the dry run is  $1.6 \times 10^{-5} \text{ sec}^{-1}$  or about twice the value of Fig. 16, an increase of rate which may be due to the presence of water.

### b. Effect of Inhibitors

Two kinds of experiments were carried out to test for the presence of a kinetic chain (free-radical or ionic) in the decomposition. A 0.67 M solution of 1,2 DP in nitrobenzene containing 5 mole percent of 2,6-di-*t*-butyl-4-methylphenol, a well-known free radical scavenger,<sup>16</sup> was heated for 5 hours at 163°C. The solution became very dark and 66 percent of 1,2 DP disappeared. A 1 M solution without inhibitor decomposed more slowly, with 70 percent decomposition in 10 hours. A nitrobenzene solution of the inhibitor alone gave no color change on heating for twenty hours.

<sup>16</sup>G. S. Hammond, J. N. Ser, and C. E. Boozer, J. Amer. Chem. Soc., 77, 3244 (1955)

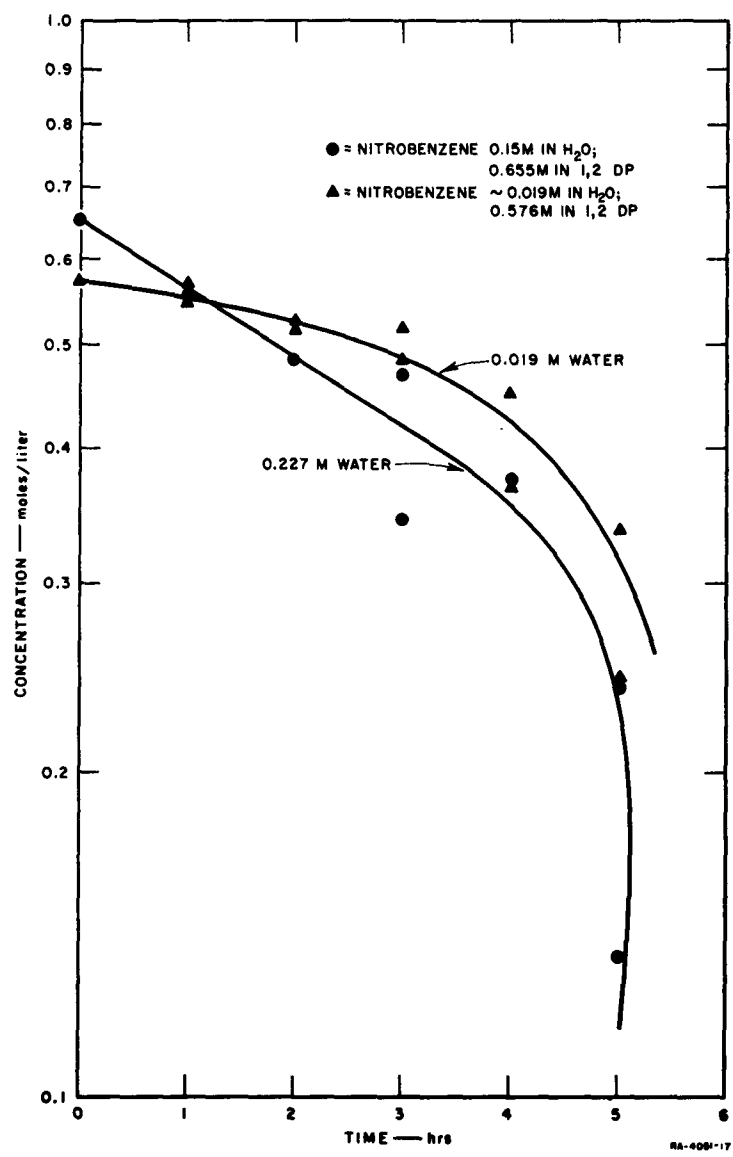

FIG. 18 FIRST ORDER PLOTS FOR THERMAL DECOMPOSITION  
 OF 1,2 DP IN DRY (0.019 M water) AND WET (0.227 M water)  
 NITROBENZENE SOLUTIONS

## CONFIDENTIAL

A 0.5 M solution of 1,2 DP in  $\alpha$ -methylstyrene, an efficient radical and proton trap,<sup>17</sup> was sealed in an NMR sample tube. After heating at 163°C for 5 hours, the solution was very dark. An F<sup>19</sup> NMR spectrum of the contents showed an absence of bands due to 1,2 DP<sup>18</sup>, but the presence of two weak bands well upfield (128 and 148 ppm from CCl<sub>3</sub>F) from the NF<sub>2</sub> bands of 1,2 DP. The position of these new bands suggests they are due to carbon-bonded fluorine. Other F<sup>19</sup> nuclei may have escaped detection in the spectrometer because of band broadening in the tarry product or because of loss of volatile SiF<sub>4</sub> into the void above the liquid.

The acceleration in rate found with both the di-butyl methylphenol and the  $\alpha$ -methylstyrene seems to rule out the possibility of a free-radical chain decomposition.

### c. Container Effects

Although wall effects in solution kinetics are unusual, this system may involve formation of hydrogen fluoride, and its interaction with glass or metal oxides could introduce spurious kinetic effects. To assess the importance of wall effects, 0.3-0.5 M solutions of 1,2 DP in nitrobenzene were heated in stainless steel and glass vessels and in a glass tube packed with glass wool. Rates were followed by removing aliquots at various intervals. No great difference in initial rates was found; the packed tube rate was twice that of the other glass or steel vessels. Differences between steel and glass were no greater than among different runs in glass.

Several runs were made using sealed steel and brass vessels. The product of decomposition was grossly the same in all runs, a dark polymer with the odor of hydrogen fluoride.

---

<sup>17</sup>F. R. Mayo and C. Walling, Chem. Revs. 46, 191 (1950)

<sup>18</sup>F<sup>19</sup> NMR spectra of difluoroamino compounds are reported in Rohm and Haas Quarterly Progress Report P-60-10, May 31, 1960, p. 24 (Conf.); all compounds exhibit bands at -4000 to -5000 cps from CF<sub>2</sub>COOH. Z has bands at -2134 cps and -3219 cps from CCl<sub>3</sub>F (-37.8 and -57.1 ppm from CCl<sub>3</sub>F).

# CONFIDENTIAL

## d. Decomposition Products

Several intermediate, volatile products were observed in gas chromatograms. At no time did the total mass of these products appear to account for the loss of 1,2 DP and on prolonged heating they disappeared, an indication of their intermediate character. (Water cannot be detected with the chromatographic column used for these analyses.) Two peaks in the chromatogram were present in significant amounts. These are shown in Fig. 15 labeled 3 and 4. Methylene chloride, the solvent from which 1,2 DP is isolated, was normally present to the extent of 1 percent in distilled 1,2 DP. The compound, free of  $\text{CH}_2\text{Cl}_2$ , behaves in an identical way to the other samples. Peaks 3 and 4 were isolated by gas chromatography and their mass spectra obtained. Peak 3 has the cracking pattern of acetonitrile ( $\text{CH}_3\text{CN}$ ) and a retention time identical to  $\text{CH}_3\text{CN}$  in the chromatograph. Peak 4 displays a significant peak at  $m/e = 86$  in the mass spectrum. We were unable to clear the spectrum of possible impurities (1,2 DP, water, acetone, air) to give residual pattern in reasonable accord with structures having a parent mass of 86. One such reasonable structure is  $\text{CH}_3\text{C}(\text{NF})\text{CN}$ .

Several samples of polymer have been isolated from the decompositions of 1,2 DP in liquid solution, and vapor phase. None of the analyses is satisfactory for CHN balance; no fluorine analysis has been obtained. Water very probably contributes some oxygen to the polymer. Most samples of polymer are insoluble in acetone, suggestive of a highly condensed system with few functional groups such as carbonyl or hydroxyl.

## e. Solvent Effects

In one experiment hexadecane was substituted for nitrobenzene. A sealed NMR tube was used as the container and the  $\text{F}^{19}$  spectrum of a sample heated 18 hours at  $163^\circ\text{C}$  showed little change in the intensity of the two fluorine bands, compared to the spectrum of the unheated solution. Both spectra were obtained at about the same time. A similar solution in nitrobenzene had half decomposed in 6 to 7 hours.

# CONFIDENTIAL

## f. Reaction with Alkoxide Ion

One mmole of 1,2 DP dissolved in n-butanol (chosen for convenience in the gas chromatographic analysis) was treated with 4 mmoles of sodium butoxide in butanol over a 12-hour period at 25°C. Samples were chromatographed at intervals. 1,2 DP was very rapidly consumed after each addition of base, and product peaks which appeared in the chromatograms corresponded to only a small fraction of the consumed starting material. These products are identical with those observed in thermal decomposition experiments (Fig. 15) with respect to both retention times and peak shapes.

## 3. Discussion

### a. Rate Equation and Rate Constants for Thermal Decomposition in Nitrobenzene Solution

The results shown in Figs. 12 and 13 indicate that the decomposition of 1,2 DP in nitrobenzene is initially first order, with accumulation of an intermediate or intermediates producing autocatalysis. Figure 16 gives composite results of several runs at 176°C, as plots of log concentration vs. time. The data yield good straight lines for 20-30 percent of reaction. Over an almost five-fold change in initial concentration from 0.56 to 0.14 moles/liter the initial slopes are identical within experimental error and give a value  $k_1 = 1.0 \times 10^{-5} \text{ sec}^{-1}$  at 176°C. At 187°C the plot of log concentration versus time gave similar results with greater scatter (Fig. 17). By a least squares calculation for straight line fits of the points over the first 20-30 percent of decomposition, the value of  $k_1$  was found to be  $3.0 \times 10^{-5} \text{ sec}^{-1}$  at 187°C.

Assign A as the original concentration of 1,2 DP, and x the amount which has been converted into product at any given time. Then if one assumes that acceleration is caused either by a primary product or by a secondary product produced rapidly compared to the rate-controlling step, the rate is described by the equation

$$\text{rate} = dx/dt = k_1(A - x) + k_2(A - x)(x)^y. \quad (4-1)$$

# CONFIDENTIAL

Since

$$k_2 = nk_1, \quad (4-2)$$

Eq. (4-1) becomes

$$dx/dt = (A - x)k_1(1 + nx^y) \quad (4-3)$$

If we define an average rate  $\bar{R} = \Delta x/\Delta t$ , then Eq. (4-3) becomes

$$[\bar{R}/k_1(A - x)] - 1 = nx^y \quad (4-4)$$

Table VI gives calculated values of  $x$ ,  $\bar{R}$ , and  $k_1(A - x)$  for a run at 176°C with a 0.461 M solution in nitrobenzene, assuming  $k_1 = 1.0 \times 10^{-5} \text{ sec}^{-1}$ . A plot of these data in terms of  $\log \bar{R}/k_1(A - x)$  vs.  $\log x$  is shown in Fig. 19. After 7 hours the points fall on a straight line. Since

Table VI  
RESULTS OF KINETICS EXPERIMENT WITH 0.461 M 1,2 DP  
IN NITROBENZENE AT 176°C

Time (hrs)	$x \cdot 10^{-2}$ (moles/liter)	$\bar{R} \cdot 10^2$ (moles/liter/hr)	$k_1(A - x) \cdot 10^2$ (moles/liter/hr)
0	0	1.4	1.6
1	1.4	1.5	1.56
2	2.9	1.6	1.51
3	4.5	1.5	1.46
4	6.0	1.6	1.40
5	7.6	1.8	1.35
6	9.4	2.4	1.28
7	10.0	3.1	1.20
8	14.9	3.8	1.09
9	18.7	4.3	0.959
10	23.0	4.5	0.809
11	27.5	4.4	0.651
12	31.9	4.3	0.497
13	36.2		0.347

CONFIDENTIAL

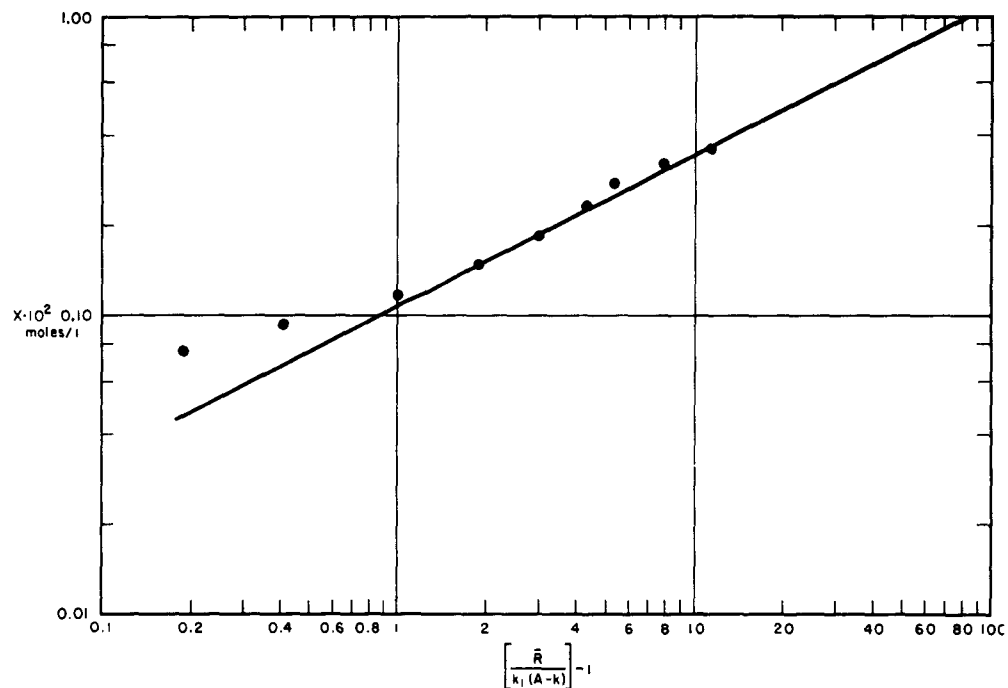

FIG. 19 LOG-LOG PLOT OF  $\left[\frac{\bar{R}}{k_1(A-k)}\right]^{-1} = nx^y$  FOR 0.416 M SOLUTION OF 1,2 DP IN NITROBENZENE AT 176°C

$\bar{R}$  and  $x$  change most slowly during the first 7 hours, the changes in  $x$  are subject to the greatest experimental error in that period. For this reason, the early points were ignored in plotting the straight line. The slope gave a value of  $y = 2.07$ . When the line was adjusted to  $y = 2.0$ , the intercept gave  $n = 83$ . A similar analysis was carried out for the runs at 187°C and for a value  $y = 2$ ,  $n = 64$  was obtained. By Eq. (4-2)  $k_2$  is found to be  $8.2 \times 10^{-4}$  liter<sup>2</sup>/mole<sup>-2</sup>/sec<sup>-1</sup>. Figure 20 shows a comparison of the curves by plotting (a)  $\bar{R}$  from Table VI versus time, shown as circles, and (b) Eq. (4-3) for  $n = 83$ ,  $y = 2$ , shown as triangles. The correlation is reasonably good. Thus the following equation describes the over-all decomposition at 176°C in nitrobenzene:

CONFIDENTIAL

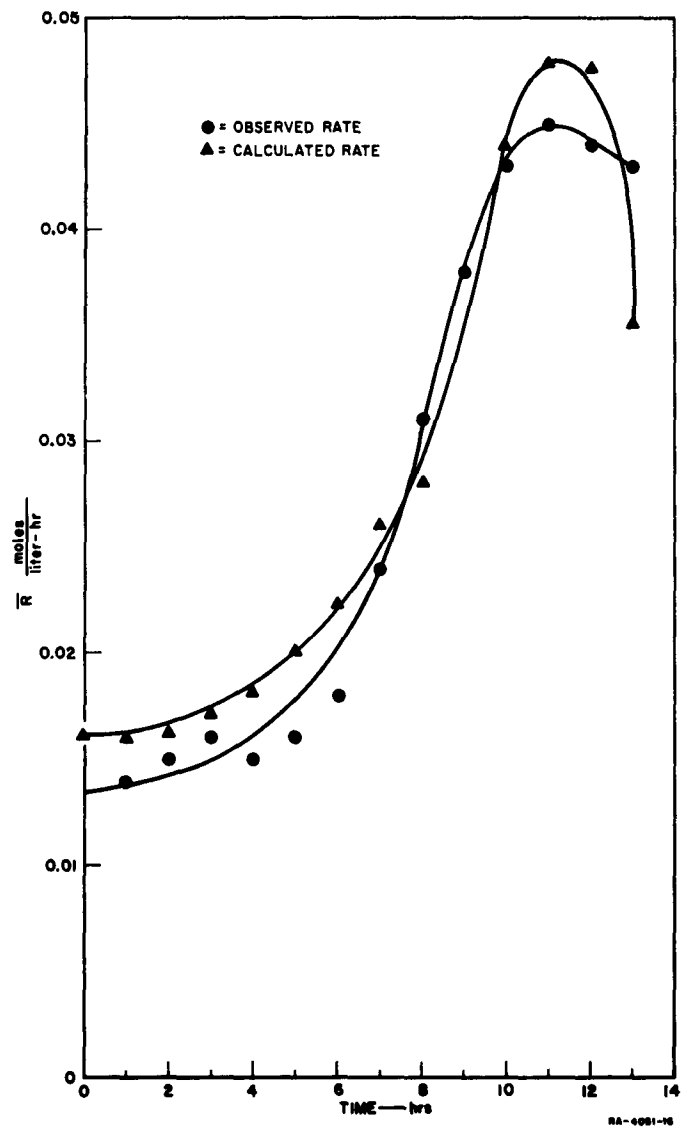

FIG. 20 PLOTS OF RATE vs. TIME FOR 0.46 M 1,2 DP  
 IN NITROBENZENE AT 176°C - EXPERIMENTAL  
 DATA AS SHOWN IN TABLE VI - EQ. (4.3) FOR  
 $n = 80, \gamma = 2$

## CONFIDENTIAL

$$dx/dt = 1.0 \times 10^{-5} (A - x)(1 + 83x^2) \quad \text{moles/liter}^{-1}/\text{sec}^{-1} \quad (4-5)$$

Similar treatment of the run at 187°C gave

$$dx/dt = 3.0 \times 10^{-5} (A - x)(1 + 64x^2) \quad \text{moles/liter}^{-1}/\text{sec}^{-1}. \quad (4-6)$$

Arrhenius parameters,  $\nu$  (frequency factor) and  $E_a$  (activation energy) were calculated from the values of  $k_1$  and  $k_2$  at 176 and 187°C. They are given in Table VII.

Table VII  
KINETIC PARAMETERS FOR THERMAL DECOMPOSITION  
OF 1,2 DP IN NITROBENZENE

Rate Constant	T (°K)	$E_a$ (kcal/mole)	$\nu$ (sec <sup>-1</sup> )
$k_1$	449	40.2 ± 2	3.7 × 10 <sup>14</sup>
	460		
$k_2$	449	35.7 ± 2	1.8 × 10 <sup>14</sup>
	460		

### b. Decomposition Mechanism in Nitrobenzene Solution

In principle several unimolecular decomposition pathways are available to 1,2 DP. Thermochemical considerations suggest that either an ionic (polar) dissociation involving loss of hydrogen fluoride or a free radical cleavage of a C-N bond are the most probable modes of decomposition. The bulk of the experimental evidence supports a mechanism involving a rate-controlling loss of hydrogen fluoride.

The diminution in rate in going from the vapor phase (where the reaction probably occurs on the walls) to hexadecane and to nitrobenzene solutions is indicative of the formation of a polar transition state, or increased solvation of products compared to reactants, or both.<sup>19</sup> An alternative explanation that there is change in mechanism accompanying a change in phase or solvent is unlikely in view of the similarity of the products formed and the over-all kinetic behavior exhibited under these different conditions. The observation that butoxide ion gives the same

<sup>19</sup>A. A. Frost and R. G. Pearson, *Kinetics and Mechanism*, John Wiley and Son, Inc., New York, 1953, p. 117.

## CONFIDENTIAL



## CONFIDENTIAL

Water is known to catalyze this decomposition, a fact which is consistent with the proposed mechanism. Probably this catalysis is associated with water's nucleophilic character rather than with any alteration of the solvating properties of the solvent. Since water is a secondary product in the reaction, produced by the reaction

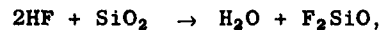

it is of interest to inquire whether water could be the product responsible for autocatalysis. The experiment in which water was added initially to the nitrobenzene solution provides a way of testing this hypothesis.

The concentration of water is substituted into Eq. (4-1) to the first power

$$\text{rate} = dx/dt = k_1(A - x) + k_2(A - x)(\text{H}_2\text{O}). \quad (4-7)$$

Solving for the initial rate, i.e., when  $(A - x) = (A)$ , in a nitrobenzene solution containing 0.655 M 1,2 DP and 0.277 M  $\text{H}_2\text{O}$ , one obtains a value for the initial rate of  $1.56 \times 10^{-4}$  mole/liter<sup>-1</sup>/sec<sup>-1</sup>. This is almost four times the measured value of  $4 \times 10^{-5}$  mole-liter<sup>-1</sup>/sec actually found for the water-catalyzed reaction, and the difference is well beyond the experimental error. One therefore concludes that water is not a sufficiently strong nucleophile to account for the observed results.

The marked surface effects found in vapor-phase decompositions must reflect the fact that the reaction occurs largely at the walls. In steel bulbs, HF produces ferric fluoride, a Lewis acid which presumably can catalyze the initial decomposition by associating with a nitrogen-bound fluorine

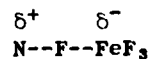

Glass bulbs exhibit an inhibiting effect with continued use. It may be that deposition of an organic film on the glass simply covers up active sites already present on the walls. Surface effects have also been found in the vapor-phase decomposition of IBA by Booman.<sup>20</sup> He recently

---

<sup>20</sup>K. Booman. Private communication to M. E. Hill, March 15, 1963.

## CONFIDENTIAL

reported new evidence indicating that IBA decomposes by loss of HF rather than by a radical cleavage, and that the rate is accelerated in steel vessels ( $\text{FeF}_3$  catalysis) but inhibited in brass vessels.

c. Speculation on Mechanisms and Rates in Pure Liquid and at High Temperature

It is of interest to consider the applicability of the available kinetic data to the pure liquid decomposition, and to inquire into the relationship between the low temperature kinetic behavior and the very fast high temperature kinetics associated with detonation.

Extrapolation of  $k_1$  from Eq. (4-5) to the rate in the pure liquid at  $153^\circ$  indicates that  $t_{1/2} \sim 200$  hrs, whereas the experimental value (see Section B-1-a) was about 20 hrs. However this latter value of  $t_{1/2}$  was associated with the period of rate acceleration, and the discrepancy may be due in part to the rapid onset of catalysis which is a consequence of the higher concentration.

Since the decomposition reaction is polar and shows a solvent effect, perhaps the fundamental question concerns how nitrobenzene and 1,2 DP differ as solvents for this reaction. At this time we can do no more than indicate some possible differences and possible consequences of these differences. A reaction involving a polar transition state, i.e., a state having charge separation, will display marked sensitivity of the rate to the dielectric character of the medium.<sup>21</sup> Nitrobenzene has a high dielectric constant<sup>22</sup> of 35. The value for 1,2 DP is unknown; a reasonably close model may be 1,2-dichloroethane, which has a value<sup>22</sup> of about 10. On this basis, one would expect a polar reaction to proceed less rapidly in 1,2 DP than in nitrobenzene, contrary to the observed result.

If hydrogen fluoride catalyzes the decomposition by interaction with the leaving fluoride,<sup>23</sup> then the ability of each solvent to complex

<sup>21</sup>A. Streitweiser, Chem. Rev., 56, 615 (1956)

<sup>22</sup>J. Hine, Physical Organic Chemistry, McGraw-Hill, New York, 1962, p. 39

<sup>23</sup>A. Streitweiser, Op. Cit. p. 622

## CONFIDENTIAL

with HF will have a marked kinetic effect. Nitrobenzene can probably complex HF effectively through interaction of the aromatic ring with the proton. Similar complexing by 1,2 DP would be expected to lead to decomposition of 1,2 DP. If this is correct, the rate of decomposition should be faster in the neat liquid than in nitrobenzene solvent, consistent with the observed results. Unknown factors may further complicate the situation. Until more is known regarding the mechanism of catalysis, we cannot properly weigh all of the factors affecting the change in rate in going from solution to the pure liquid.

Should rate-controlling steps, alternative to the one proposed, become predominant at high temperatures associated with the detonation wave (1000<sup>o</sup>-2000<sup>o</sup>K) then the kinetic parameters derived from rate studies at 176-187<sup>o</sup>C become inapplicable. We find no evidence for the presence of a competing unimolecular or bimolecular reaction based on product distribution changes on changing the reaction solvent or phase. Nevertheless, a reaction which proceeds at one-tenth the rate of the principal reaction at 187<sup>o</sup>C (460<sup>o</sup>K) will constitute 26 percent of the over-all decomposition at 1000<sup>o</sup>K, assuming temperature-independent frequency factors for both reactions. A self-initiated free-radical chain reaction might become important at high temperatures, despite little or no evidence for its presence at low temperatures.

Another apparent objection to the use of low temperature kinetic data for detonation phenomena in the case of 1,2 DP arises from the fact that the final product of low temperature decompositions is a polymer, whereas one expects gaseous products in a detonation wave. However since most organic compounds decompose at appreciable rates above 600<sup>o</sup>K, there is a ceiling temperature above which no polymer is formed; thus, secondary reactions which lead to polymer at low temperature are supplanted at high temperature by alternative decomposition paths which give gaseous products and probably carbon.

# CONFIDENTIAL

## C. Kinetics of the Thermal Decomposition of 2,2 DP

### 1. Experimental

Samples of 2,2 DP were supplied as a 25 percent solution in Aroclor. One to 2 ml quantities were distilled on the vacuum line by pumping the vapor through a nitrogen-cooled trap at  $10^{-3}$  mm Hg. This procedure failed to remove all of the 2,2 DP from the solvent, even though we have found 2,2 DP to be rather fugitive in nitrobenzene.

Studies of the decomposition of the vapor were carried out in the same way as the vapor phase studies of 1,2 DP. In all cases neat 2,2 DP was prepared and handled remotely on the vacuum line. Decomposition at  $200^{\circ}\text{C}$  was accompanied by formation of a brown polymer on the walls of glass vessels; some evidence of etching was noted. The intermediate products observed in the gas chromatography were different from those found in the decomposition of 1,2 DP. A typical chromatogram for the decomposition mixture is shown in Fig. 21.

### 2. Results and Discussion

The few vapor phase experiments with 2,2 DP at  $200^{\circ}\text{C}$  indicate that it is more stable than 1,2 DP by a factor of five or more; the half-life of 2,2 DP at  $200^{\circ}\text{C}$  in new glass is about 57 hours. Studies in nitrobenzene solution at  $187^{\circ}\text{C}$  indicate that it is more stable in solution as well.

This difference in rate of decomposition must reflect a difference in mechanism, with initial loss of  $\text{NF}_2$  or  $\text{HNF}_2$  rate-controlling in the case of 2,2 DP. This loss of  $\text{HNF}_2$  is less exothermic than loss of HF. Some HF was formed in the decomposition of 2,2 DP. One bulb heated for 80 hours lost  $0.35 \times 10^{-3}$  moles of 2,2 DP and gained  $0.07 \times 10^{-3}$  moles of water. This corresponds, assuming that all of the HF is converted to water on the walls, to 10 percent of the HF expected if each molecule of 2,2 DP loses one molecule of HF.

**CONFIDENTIAL**

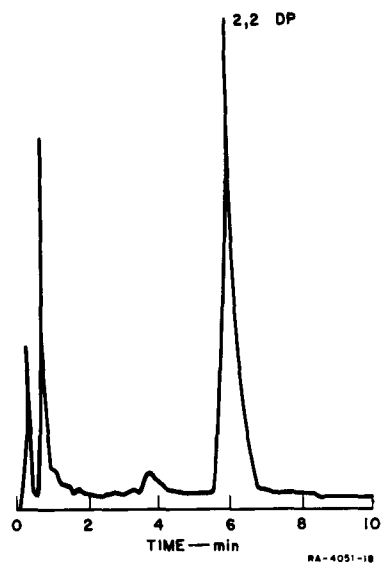
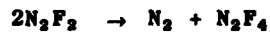
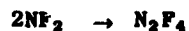
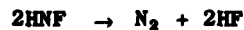
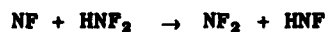
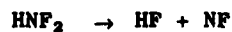

FIG. 21 CHROMATOGRAM OF DECOMPOSITION PRODUCTS OF NITROBENZENE SOLUTION OF 2,2 DP OBTAINED ON A 5-FT DINONYLPHTHALATE COLUMN AT 76°C AND 30 ml/min FLOW RATE

Direct formation of HF with concomitant formation of N-fluoroimine is improbable for steric reasons. A more plausible path for HF formation is



with a possible mechanism involving fluoronitrene (NF):



**CONFIDENTIAL**

# CONFIDENTIAL

## D. Future Plans

Experiments will be carried out to determine the mechanisms of catalysis found in the decomposition of both 1,2 DP and 2,2 DP. The structural features of the final residues from both these reactions will be established and the catalytic activity of each of these residues will be measured.

A more rigorous proof will be provided for 2-(fluoroimino)propionitrile, one of the decomposition products from 1,2 DP. The role of this product in the over-all decomposition will be examined. Similar experiments will be made for intermediates arising from the decomposition of 2,2 DP.

Further vapor-phase decomposition studies will be carried out with both 1,2 DP and 2,2 DP at higher temperatures, using manometric techniques, if possible, both to establish the kinetic characteristics of these reactions and to search for evidence for new, high temperature reactions which may be important in detonation reactions.

Studies similar to those described in this report will be done with the two other propane isomers, 1,3 DP and 1,1 DP in order to provide as broad as possible basis for generalizations concerning the relation of structure and reactivity for NF compounds.

# CONFIDENTIAL

## ACKNOWLEDGMENTS

The authors wish to acknowledge the contribution of Anna Longwell, who conducted the adiabatic self-heating experiments; of Marilynne Smart for the experimentation in thermal decomposition kinetics; of Derek Tegg, who was responsible for the isolation and handling of the test compounds; of Roger Kier, John L. Smith, Walter Johnson, and David Tingey, who assisted in the adiabatic self-heating and detonation experiments, and of personnel of the Mathematical Sciences Department for many of the theoretical calculations.

**CONFIDENTIAL**

Appendix

PREPARATION AND PROPERTIES OF  
1,2- AND 2,2-BIS(DIFLUOROAMINO)PROPANE

55

**CONFIDENTIAL**

# CONFIDENTIAL

## Appendix

### PREPARATION AND PROPERTIES OF 1,2- AND 2,2-BIS(DIFLUOROAMINO)PROPANE

Three pounds of 1,2-bis(difluoroamino)propane were prepared by the duPont Eastern Laboratories, Gibbstown, New Jersey, by the addition of  $N_2F_4$  to propylene. The compound was shipped as a 20% solution in methylene chloride. Material of 99% purity or better was obtained from this solution by stripping off the methylene chloride by remote distillation. Further purification on a dinonylphthalate gas chromatograph column provided material of 99.8% purity for the kinetic experiments.

Approximately 1 pound of 2,2-bis(difluoroamino)propane has been prepared by Aerojet-General Corporation in Azusa by addition of difluoroamine to acetone in sulfuric acid. The compound was received as a 2 to 1 solution of the propane in Aroclor 1248. Extensive tests of the shipping solution have been made at Aerojet in order to determine if any serious shipping hazards existed. Impact sensitivity values for the solution were reasonable and friction tests were negative. Static sensitivity tests indicated that a fire hazard, but no explosion hazard, existed for the 2 to 1 solution. However, 1 to 1 solutions will explode by spark initiation. The pure material is sensitive to static discharge, being explosive over the range of energy that a human body can accumulate. Isolation of the pure compound (>99%) was obtained by remote distillation under reduced pressure.

Physical properties of the two materials are summarized in Tables A-I and A-II.

# CONFIDENTIAL

Table A-I  
PHYSICAL PROPERTIES OF  
1,2-BIS(DIFLUOROAMINO)PROPANE

Compound:  $\text{CH}_3\text{CH}(\text{NF}_2)\text{CH}_2(\text{NF}_2)$   
Boiling Point:  $81^\circ\text{C}^1$

Vapor Pressure <sup>1</sup>	
T( $^\circ\text{C}$ )	P(mm Hg)
-25.4	4.2
-13.0	9.15
0.1	20.70
10.4	36.30
24.4	72.25

Impact Sensitivity

(Olin Mathieson Machine)

50 kg/cm<sup>1</sup>

50 kg/cm<sup>2</sup>

37 kg/cm<sup>2</sup>

7 inches/5 kg<sup>4</sup>

Static Sensitivity<sup>4</sup>

25,600 man equiv. volts

Body static discharge - 11,000 mev

Freezing Point:  $-90^\circ\text{C}$

Density: 1.256 g/ml at  $24^\circ\text{C}$ ;<sup>1</sup> 1.178 g/ml at  $25^\circ\text{C}$ <sup>2</sup>

Adiabatic Compression Sensitivity: 13 kg-cm/ml

Nitromethane 10.4 kg-cm/ml<sup>1</sup>

Thermal Stability:  $251^\circ\text{C}$  (decomposition temperature);<sup>1</sup>

Hot Bar: Evap'd. at  $250^\circ\text{C}$ <sup>4</sup>

Est'd Activation Energy: 73 kcal/mol<sup>1</sup>

Heat of Formation: -40.4 kcal/mole<sup>3</sup>

Heat Capacity:  $0.348 \pm 0.005$  cal/deg/g<sup>5</sup>

<sup>1</sup>Stauffer Chemical Company, Private communication

<sup>2</sup>Stanford Research Institute

<sup>3</sup>Thermochemical Panel Meeting, July 1961, at Aerojet-General Corporation, Scaramento, California

<sup>4</sup>DuPont, Private communication

<sup>5</sup>H. Eding, Stanford Research Institute

# CONFIDENTIAL

# CONFIDENTIAL

Table A-II  
PHYSICAL PROPERTIES OF  
2,2-BIS(DIFLUOROAMINO)PROPANE

Compound:  $\text{CH}_3\text{C}(\text{NF}_2)_2\text{CH}_3$

Boiling Point:  $73^\circ\text{C}^1$  (Vapor press at  $25^\circ = 90 \text{ mm}^2$ )

Freezing Point: About  $0^\circ\text{C}^1$

Impact Sensitivity:  $53 \text{ cm}/2 \text{ kg}^1$   
"Erratic"<sup>3</sup>  
 $25\text{-}28 \text{ kg cm for 7 shots}^2$

Spark Sensitivity: Explosion by 0.05 joule discharge<sup>3</sup>  
(Body discharge energy--0.02-0.07 joule)<sup>3</sup>

Adiabatic Compression Sensitivity: "Good"<sup>3</sup>

Thermal Stability: Stable "at least to its boiling point"<sup>1</sup>

<sup>1</sup>Aerojet-General Corporation; Report 0235-01-10

<sup>2</sup>Rohm and Haas; Report P60-24

<sup>3</sup>J. R. Fisher, Aerojet-General Corporation, Private Communication

**STANFORD  
RESEARCH  
INSTITUTE**

**MENLO PARK  
CALIFORNIA**

## **Regional Offices and Laboratories**

**Southern California Laboratories**  
820 Mission Street  
South Pasadena, California

**Washington Office**  
808 17th Street, N.W.  
Washington 6, D.C.

**New York Office**  
270 Park Avenue, Room 1770  
New York 17, New York

**Detroit Office**  
1025 East Maple Road  
Birmingham, Michigan

**European Office**  
Pelikanstrasse 37  
Zurich 1, Switzerland

**Japan Office**  
911 Iino Building  
22, 2-chome, Uchisaiwai-cho, Chiyoda-ku  
Tokyo, Japan

## **Representatives**

**Honolulu, Hawaii**  
1125 Ala Moana Blvd.  
Honolulu, Hawaii

**London, England**  
19, Upper Brook Street  
London, W. 1, England

**Milan, Italy**  
Via Macedonio Melloni, 49  
Milano, Italy

**Toronto, Ontario, Canada**  
Room 710, 67 Yonge St.  
Toronto, Ontario, Canada