

UNCLASSIFIED

AD NUMBER

AD337910

CLASSIFICATION CHANGES

TO: UNCLASSIFIED

FROM: CONFIDENTIAL

LIMITATION CHANGES

TO:  
Approved for public release; distribution is unlimited.

FROM:  
Distribution authorized to U.S. Gov't. agencies and their contractors;  
Administrative/Operational Use; 14 SEP 1959.  
Other requests shall be referred to Defense Nuclear Agency, Washington, DC.

AUTHORITY

DNA ltr 6 Dec 1985 ; DNA ltr 6 Dec 1985

THIS PAGE IS UNCLASSIFIED

**UNCLASSIFIED**

**AD \_\_\_\_\_**

**DEFENSE DOCUMENTATION CENTER**

**FOR**

**SCIENTIFIC AND TECHNICAL INFORMATION**

**CAMERON STATION ALEXANDRIA, VIRGINIA**

**DOWNGRADED AT 3 YEAR INTERVALS  
DECLASSIFIED AFTER 12 YEARS  
DOD DIR 5200.10**



**UNCLASSIFIED**

**CONFIDENTIAL**  
RESTRICTED DATA

**AD**

**337 910**

---

**DEFENSE DOCUMENTATION CENTER**

FOR

**SCIENTIFIC AND TECHNICAL INFORMATION**

CAMERON STATION, ALEXANDRIA, VIRGINIA



RESTRICTED DATA  
**CONFIDENTIAL**

NOTICE: When government or other drawings, specifications or other data are used for any purpose other than in connection with a definitely related government procurement operation, the U. S. Government thereby incurs no responsibility, nor any obligation whatsoever; and the fact that the Government may have formulated, furnished, or in any way supplied the said drawings, specifications, or other data is not to be regarded by implication or otherwise as in any manner licensing the holder or any other person or corporation, or conveying any rights or permission to manufacture, use or sell any patented invention that may in any way be related thereto.

NOTICE:

THIS DOCUMENT CONTAINS INFORMATION  
AFFECTING THE NATIONAL DEFENSE OF  
THE UNITED STATES WITHIN THE MEAN-  
ING OF THE ESPIONAGE LAWS, TITLE 18,  
U.S.C., SECTIONS 793 and 794. THE  
TRANSMISSION OR THE REVELATION OF  
ITS CONTENTS IN ANY MANNER TO AN  
UNAUTHORIZED PERSON IS PROHIBITED  
BY LAW.

337910

**CONFIDENTIAL**

AIR FORCE  
BALLISTIC MISSILE DIVISION

TECHNICAL LIBRARY

Document No. K-504

Copy No. \_\_\_\_\_

WT-1686

This document consists of 86 pages.

No. 89 of 190 copies, Series A

20

337 910

AD No. 337910

DDC FILE COPY

# HARDTACK

April - October 1958

OPERATION  
TIMING AND FIRING

ASTIA  
MAY 16 1963  
RECEIVED  
TISA E

Issuance Date: September 14, 1959

EDGERTON, GERMESHAUSEN & GRIER, INC.  
BOSTON, MASSACHUSETTS,  
AND LAS VEGAS, NEVADA

## RESTRICTED DATA

This document contains restricted data as defined in the Atomic Energy Act of 1954. Its transmittal or the disclosure of its contents in any manner to an unauthorized person is prohibited.

DDC  
RECEIVED  
JUL 19 1963  
RECEIVED  
TISA B

EXCLUDED FROM AUTOMATIC  
REGRADING; DOD DIR 5200.10  
DOES NOT APPLY

**CONFIDENTIAL**

(4) NA (5) 282600 (7) NA (8) U  
**CONFIDENTIAL**

- (9) + (10) NA  
(11) 14 Sep 59,  
(12) 86p. (13) -  
(17) NA  
(18) DASA  
(19) Ppt. no. WT-1686  
(20) C-RD  
(21) Report on  
Operation Hardtack [U]†

Report to the Scientific Director

(6)  
TIMING AND FIRING [U]

By  
Staff of Edgerton, Germeshausen and Grier, Inc.

Approved by: F. I. Strabala  
F. I. Strabala

*Fdc*

Edgerton, Germeshausen and Grier, Inc.  
Boston, Massachusetts, and Las Vegas, Nevada  
July 1959

## RESTRICTED DATA

This document contains restricted data as defined in the Atomic Energy Act of 1954. Its transmittal or the disclosure of its contents in any manner to an unauthorized person is prohibited.

3-4

**CONFIDENTIAL**

ABSTRACT

*are presented*

On Operation Hardtack, ~~EGG~~, Germeshausen and Grier, Inc. (Task Unit 5) furnished arming and firing signals for ~~thirty-five~~ devices in addition to a sequence of timing signals for the experimental programs. ~~EGG~~ was also responsible for providing a voice countdown on all dry runs and detonations, monitoring vital information, and determining, where practicable, the time of burst and the Bhangmeter yield, *is included.*

The complexity of the shot schedule, which involved several differing modes of detonation, necessitated a multiple timing and firing installation comprising seven independent systems; three were operated from Eniwetok, two from Bikini, one on the USS Boxer, and one on Johnston Island (Operation Newsreel). Besides the four control centers, the timing and firing complex included nine island-based signal-distribution stations, as well as several shipboard stations.

A versatile timing system was devised for this operation which employed a coder-decoder combination capable of transmitting twenty-four signals. Signals were transmitted by telephone line or on radio frequencies as dictated by the individual shot requirements. The timing and firing system operated accurately and reliably, and all signals were transmitted.

*↑*

CONTENTS	Page
ABSTRACT . . . . .	5
CHAPTER 1 INTRODUCTION . . . . .	11
1.1 Objectives . . . . .	11
1.2 Procedure . . . . .	11
CHAPTER 2 TIMING AND FIRING INSTALLATIONS . . . . .	19
2.1 Eniwetok Timing Systems . . . . .	19
2.2 Eniwetok Control Point . . . . .	19
2.3 Bikini Timing Systems . . . . .	26
2.4 Bikini Control Point . . . . .	26
2.5 Timing Signal Distribution Stations . . . . .	33
CHAPTER 3 BOXER INSTALLATION . . . . .	37
3.1 Control Center . . . . .	37
3.2 Rack Description . . . . .	39
CHAPTER 4 TIMING SYSTEM COMPONENTS . . . . .	40
4.1 Control Console . . . . .	40
4.2 World-Time Synchronizer . . . . .	40
4.3 Stepping-Switch Sequence Timer, Type SA-4 . . . . .	45
4.4 Signaling Decoder . . . . .	49
4.5 Signal Distribution . . . . .	53
4.6 Zero Racks . . . . .	54
4.7 Zero Fiducial Flash . . . . .	61
CHAPTER 5 RADIO TONE SYSTEMS . . . . .	62
5.1 Radio-Tone Timing and Firing Signals . . . . .	62
5.2 Radio Fiducial System . . . . .	64
5.3 Radio Telemetry . . . . .	69
5.4 Howler Monitoring . . . . .	72
CHAPTER 6 OPERATION NEWSREEL TIMING AND FIRING . . . . .	73
6.1 Introduction . . . . .	73
6.2 Timing and Firing Commitments . . . . .	73
6.3 Components of Timing and Firing System . . . . .	73
6.4 Operation of Timing and Firing Equipment . . . . .	76
6.5 Operation of Communications System . . . . .	77
CHAPTER 7 WORLD TIME DETERMINATION . . . . .	78
7.1 General . . . . .	78
7.2 Operation . . . . .	78
7.3 Summary of Results . . . . .	79

CHAPTER 8 COMMUNICATIONS . . . . .	82
8.1 EG&G Communications . . . . .	82
8.2 Voice-Time Networks . . . . .	82
8.3 Radio-Tone Networks . . . . .	84

ILLUSTRATIONS

CHAPTER 1 INTRODUCTION

1.1 Basic timing and firing system . . . . .	15
1.2 Weather radar console. . . . .	17

CHAPTER 2 TIMING AND FIRING INSTALLATIONS

2.1 Eniwetok timing systems. . . . .	20
2.2 Power, world-time, and Yvonne system racks. . . . .	21
2.3 Janet and Glenn system racks . . . . .	23
2.4 Radio and Bhangmeter racks . . . . .	25
2.5 Bikini timing systems (including How missile system). . . . .	27
2.6 Power, world-time, and How system racks . . . . .	28
2.7 Charlie and Tare system racks. . . . .	30
2.8 Bhangmeter and radio racks . . . . .	32
2.9 Typical timing station . . . . .	35

CHAPTER 3 BOXER INSTALLATION

3.1 Control room, USS Boxer . . . . .	38
---------------------------------------	----

CHAPTER 4 TIMING SYSTEM COMPONENTS

4.1 Eniwetok control console. . . . .	41
4.2 Typical control panel . . . . .	42
4.3 World-Time Synchronizer, Type SN-1. . . . .	43
4.4 Schematic diagram of world-time synchronizer. . . . .	44
4.5 Stepping-Switch Sequence Timer, Type SA-4 . . . . .	46
4.6 Schematic diagram of stepping-switch sequence timer . . . . .	47
4.7 Signal Decoder, Type SA-5. . . . .	50
4.8 Schematic diagram of Signal Decoder, Type SA-5A . . . . .	51
4.9 Signal Distribution Control Unit, Type SA-2 . . . . .	53
4.10 Zero rack . . . . .	55
4.11 Zero rack panel. . . . .	56
4.12 Schematic diagram of Zero Rack, Type SA-8. . . . .	57
4.13 Schematic diagram of Zero Rack, Type SA-9. . . . .	58
4.14 Umbrella zero rack . . . . .	59
4.15 Radio-operated zero rack . . . . .	60
4.16 Flashbulb array. . . . .	61

CHAPTER 5 RADIO TONE SYSTEMS

5.1 Block diagram, radio-tone signal system . . . . .	63
5.2 Radio relay unit. . . . .	65
5.3 Schematic diagram of radio relay unit. . . . .	66

5.4	Schematic diagram of radio fidu transmitter . . . . .	67
5.5	Schematic diagram of radio fidu receiver . . . . .	68
5.6	Block diagram, radio telemetering system. . . . .	70
5.7	Schematic diagram, telemetering decommutator unit . . . . .	71

**CHAPTER 6 OPERATION NEWSREEL TIMING AND FIRING**

6.1	Control room, Johnston Island . . . . .	74
-----	---	----

**CHAPTER 7 WORLD TIME DETERMINATION**

7.1	World-time indicator . . . . .	78
7.2	Schematic diagram of world-time indicator . . . . .	80

**TABLES**

**CHAPTER 1 INTRODUCTION**

1.1	Hardtack Detonation Summary . . . . .	13
-----	---------------------------------------	----

**CHAPTER 2 TIMING AND FIRING INSTALLATIONS**

2.1	Timing Signal Distribution Stations . . . . .	34
-----	---	----

**CHAPTER 7 WORLD TIME DETERMINATION**

7.1	World Time Summary . . . . .	81
-----	------------------------------	----

**CHAPTER 8 COMMUNICATIONS**

8.1	Communications Nets . . . . .	83
-----	-------------------------------	----

# CONFIDENTIAL

## Chapter 1

### INTRODUCTION

#### 1.1 OBJECTIVES

The objectives of the timing and firing program on Operation Hardtack were as follows:

1. To provide a reliable system for arming and firing the devices.
2. To supply experimenters with accurate wire and radio timing signals on all dry runs and on all detonations.
3. To provide experimenters with an accurate voice countdown synchronized to the timing system.
4. To furnish personnel as members of the arming and firing parties.
5. To monitor, by wire and by radio, vital information pertaining to the readiness of the test devices and of crucial experiments.
6. To determine the time of detonation with respect to world time as broadcast from WWVH, Honolulu, or JJY, Japan.
7. To provide and operate Bhangmeters, where practicable, for the preliminary determination of yield.
8. To operate weather radar equipment.

#### 1.2 PROCEDURE

##### 1.2.1 Timing and Firing

The timing and firing installation at the Eniwetok Proving Ground was far more extensive for Operation Hardtack than for previous off-continent operations. Edgerton, Germeshausen & Grier, Inc., (EG&G) provided seven independent systems to time and fire a total of thirty-five shots, comprising barge, surface, underwater, missile, and free balloon detonations.

As on Operation Redwing (1956), the test programs at Eniwetok and Bikini Atolls were conducted separately; however, for Hardtack, the firing capability at both locations was substantially increased by the installation of two standard hardwire systems at each atoll. Since the two systems served different zero areas, two shots could be set up at the same time, and less time was required for dry runs.

Shots detonated as part of the Los Alamos Scientific Laboratory (LASL) test program were served by the standard hardwire systems operated from the Eniwetok Control Point. The University of California Radiation Laboratory (UCRL) program was conducted at Bikini Atoll throughout most of the operation; however, five UCRL shots were detonated at Eniwetok Atoll after roll-up at Bikini Atoll had begun.

The test program for the Department of Defense (DOD) was considerably more complex than on previous operations, involving widely differing modes of detonation and, consequently, special installations. Timing and firing for the DOD program was entirely independent of the AEC activity. Three additional timing systems were employed to meet the individual requirements of the DOD shots: (1) a radio-signal system controlled from the Eniwetok Control Point for the underwater shots, (2) a radio and wire system located on board the USS Boxer for the high-altitude balloon shot, and (3) a radio and wire system at Johnston Island for the two missile shots of the Newsreel series.

The shots detonated by each of the timing systems are presented in Table 1. 1.

The basic timing equipment employed in six of the timing and firing systems was completely redesigned for greater capability and flexibility. The new system, shown in Fig. 1. 1, was capable of supplying experimenters with as many as twenty-four signals at any desired times in half-minute or half-second intervals from -60 min. to +1 sec. Changing or adding signals for individual shot requirements was accomplished simply by re-programming patchboards. Timing signals from the sequence timer were transmitted to each timing station as a series of coded pulses. This method of transmission required fewer cables than the previous system since all signals could be sent over a single pair of wires. At the timing station, a signal decoder converted these pulses to relay closures for operating experimenter equipment.

The air-drop sequence timer used on John Shot of Operation Plumbbob furnished the timing signals for the high-altitude balloon shot. A new model of the same timer was incorporated into the Johnston Island missile system together with the standard sequence timer.

#### 1. 2. 2 Firing System

The firing line for each zero area originated in the Control Point signal decoder. Transmission lines for the firing signals went directly from the CP to the surface and barge zero sites, passing only through the signal distribution stations where the firing lines were interlocked to assure the proper operation of vital experiments. The firing line was not otherwise affected by operation of the timing station. The zero rack contained the interlocks essential to the detonation of the device itself.

On the balloon shot (Yucca) and the missile shots at Johnston Island (Teak and Orange), EG&G furnished a relay closure at zero time to the firing equipment.

The underwater shots (Wahoo and Umbrella) were fired remotely by the EG&G radio-tone system. Tone receivers, the zero rack, and the zero-site equipment were installed on the barge positioned above the device. The firing-tone system was so arranged that a combination of any two of the three radio tones transmitted was necessary to fire the device.

#### 1. 2. 3 Voice-Time Announcements

The voice-time announcements, synchronized to the timing signal sequence, were broadcast on all dry runs and on all shot runs. On dry runs, the countdown was broadcast over the voice-time nets and the EGG net and patched into other nets as needed, such as the Air Operations Control net for participating aircraft. On the shot run, the countdown was patched into all user nets.

The countdown was given "live" from -1 hour to -15 min. by the control console operator. On the -15 minute signal the automatic voice-time equipment was started, and the countdown was broadcast from a tape recording through zero time.

Two complete voice-time racks were included in the Eniwetok Control Point, one for the two hardwire timing systems and one for the radio system for the underwater shots. One voice-time rack was also installed in the control center at Bikini and on the Boxer.

#### 1. 2. 4 Dry Runs

Frequent dry runs were conducted prior to each shot to allow experimenters to check the operation of their equipment and to assure the reliability of the timing system. At least

Table 1.1 - HARDTACK DETONATION SUMMARY

Shot	Agency	Date	Location
<u>Yvonne Timing System (Eniwetok Atoll)</u>			
Cactus	LASL	5-6-58	Surface, Yvonne
Butternut	LASL	5-12-58	Barge off Yvonne
Holly	LASL	5-21-58	Barge off Yvonne
Magnolia	LASL	5-27-58	Barge off Yvonne
Linden	LASL	6-18-58	Barge off Yvonne
Sequoia	LASL	7-2-58	Barge off Yvonne
Scaevola	LASL	7-14-58	Barge off Yvonne
Pisonia	LASL	7-18-58	Barge off Yvonne
Quince	UCRL-DOD	8-6-58	Surface, Yvonne
Fig	UCRL-DOD	8-18-58	Surface, Yvonne
<u>Janet Timing System (Eniwetok Atoll)</u>			
Koa	LASL	5-13-58	Surface, Gene
Yellowwood	LASL	5-26-58	Barge off Janet
Tobacco	LASL	5-30-58	Barge off Janet
Rose	LASL	6-3-58	Barge off Janet
Walnut	LASL	6-15-58	Barge off Janet
Elder	LASL	6-28-58	Barge off Janet
Oak	LASL	6-29-58	Barge off Janet
Dogwood	UCRL	7-6-58	Barge off Janet
Olive	UCRL	7-23-58	Barge off Janet
Pine	UCRL	7-27-58	Barge off Janet
<u>Glenn Timing System (Eniwetok Atoll)</u>			
Wahoo	DOD	5-16-58	Underwater, near James
Umbrella	DOD	6-9-58	Underwater, Eniwetok lagoon
<u>USS Boxer Timing System</u>			
Yucca	DOD	4-28-58	HA Balloon
<u>Tare Timing System (Bikini Atoll)</u>			
Nutmeg	UCRL	5-22-58	Barge off Tare
Hickory	UCRL	6-29-58	Barge off Tare
Juniper	UCRL	7-22-58	Barge off Tare
<u>Charlie Timing System (Bikini Atoll)</u>			
Fir	UCRL	5-12-58	Barge off Charlie
Sycamore	UCRL	5-31-58	Barge off Charlie
Maple	UCRL	6-11-58	Barge off Fox

HARDTACK DETONATION SUMMARY (continued)

Shot	Agency	Date	Location
<u>Charlie Timing System (Bikini Atoll) (continued)</u>			
Aspen	UCRL	6-15-58	Barge off Charlie
Redwood	UCRL	6-28-58	Barge off Fox
Cedar	UCRL	7-3-58	Barge off Charlie
Poplar	UCRL	7-12-58	Barge off Charlie
<u>Johnston Island Timing System</u>			
Teak	DOD	7-31-58	UHA Missile
Orange	DOD	8-11-58	VHA Missile

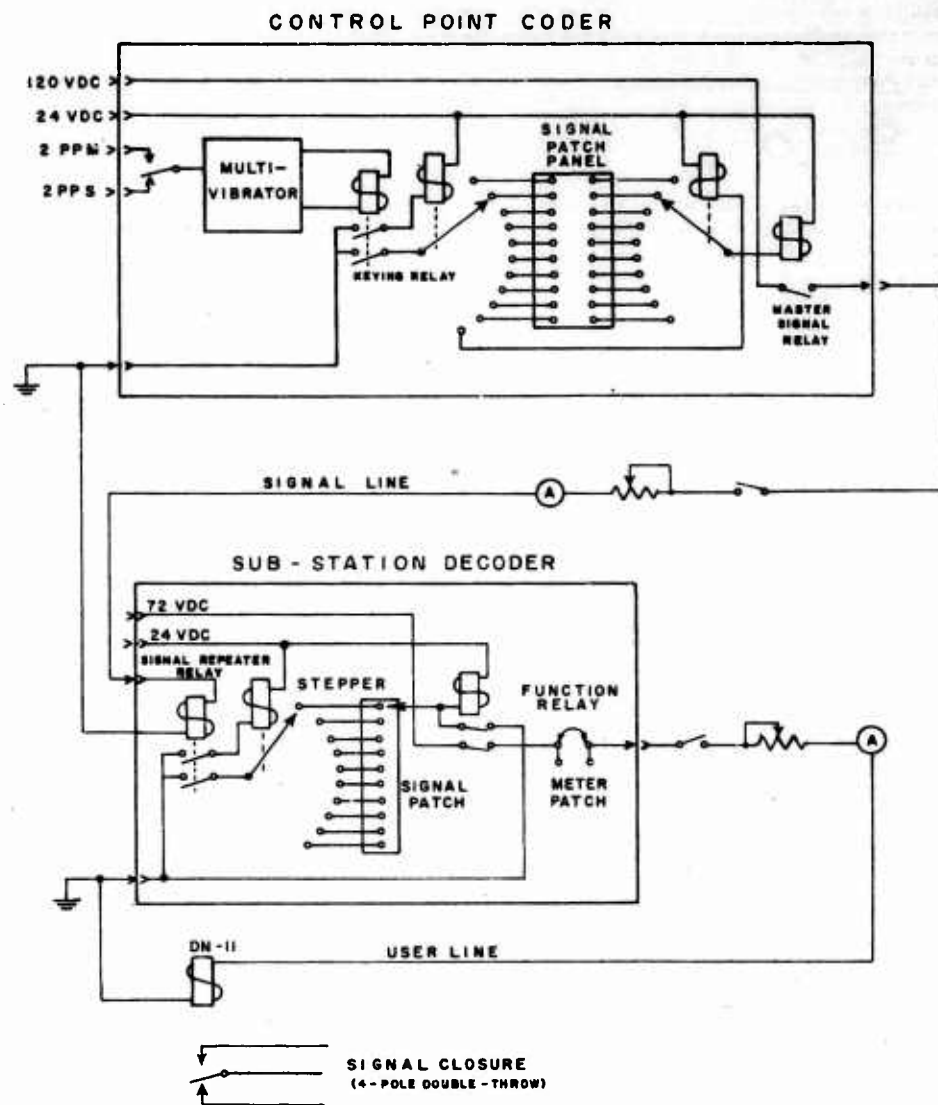

Fig. 1.1 - Basic timing and firing system

one full-power, full-frequency dry run was held to make certain that circuit overloading and radio interference had been eliminated. Experience on previous operations showed that dry runs constitute a large proportion of the timing and firing effort. The multiple capability of the independent systems and their division according to function helped to overcome the difficulties introduced by the complex shot schedule since two or more shots could be dry run independently without interference.

#### 1. 2. 5 Monitoring

Indicator lights on the timing system control panel enabled the operator to check on the function of the timing system at all important points. Distant functions were monitored by an extensive tone-telemetering system employing Hammarlund tone equipment. This system has been used on several previous operations; its advantage lies in the fact that several channels of information represented by tones of different frequencies can be transmitted on one pair of lines. Where proximity made it feasible, direct-wire monitoring was used. On the underwater events zero site functions were monitored remotely at the CP by a radio-telemetering system, and radio-tone timing and firing signals were monitored by radio-tone receivers at the CP which provided relay closures for operation of the indicator lights on the control console.

A permanent record of timing signals, station power and other important functions was obtained from multiple-pen strip-chart recorders. These recorders were installed at the CP and at each signal distribution station.

#### 1. 2. 6 Weather Data

On Operation Hardtack, timing and firing personnel operated Bendix weather radar equipment. Two radar consoles were installed, one at the Eniwetok and one at the Bikini Control Point. The Eniwetok radar console is shown in Fig. 1. 2. Antennas were located on the photo towers adjacent to each CP and were arranged so that the radar sweep covered the entire atoll; thus rain squalls in the immediate vicinity of the islands could be monitored continuously from the control room and the probable squall path predicted. The decision to fire depended in part on whether there were rain squalls in the line-of-sight from the major photographic stations to the point of detonation.

Shortly before the operation began, EG&G was requested to telemeter weather data for two shots, a 0- to 10-mv signal on two shots, and transmissometer data on three shots. Bristol miniature strip-chart recorders located in the timing system racks at Eniwetok and Bikini were used in these applications.

#### 1. 2. 7 Blue Boxes and Fiducial Markers

In addition to timing signals, remote triggering instruments capable of synchronizing equipment with the beginning of a high-intensity light flash were available to experimenters on Operation Hardtack. The ac- and dc-operated Blue Boxes were compact photoelectric devices which responded to burst light within a few milliseconds. For applications where microsecond accuracy was required, the EG&G Fiducial Marker was employed. Full descriptions of these units are included in the Timing System Manual for Operation Hardtack, EG&G Report No. B-1704.

#### 1. 2. 8 Bhangmeters

EG&G operated Bhangmeters on all shots except the underwater and missile events. Whenever practicable, yield was calculated on the basis of time-to-light minimum as determined from the Bhangmeter traces.

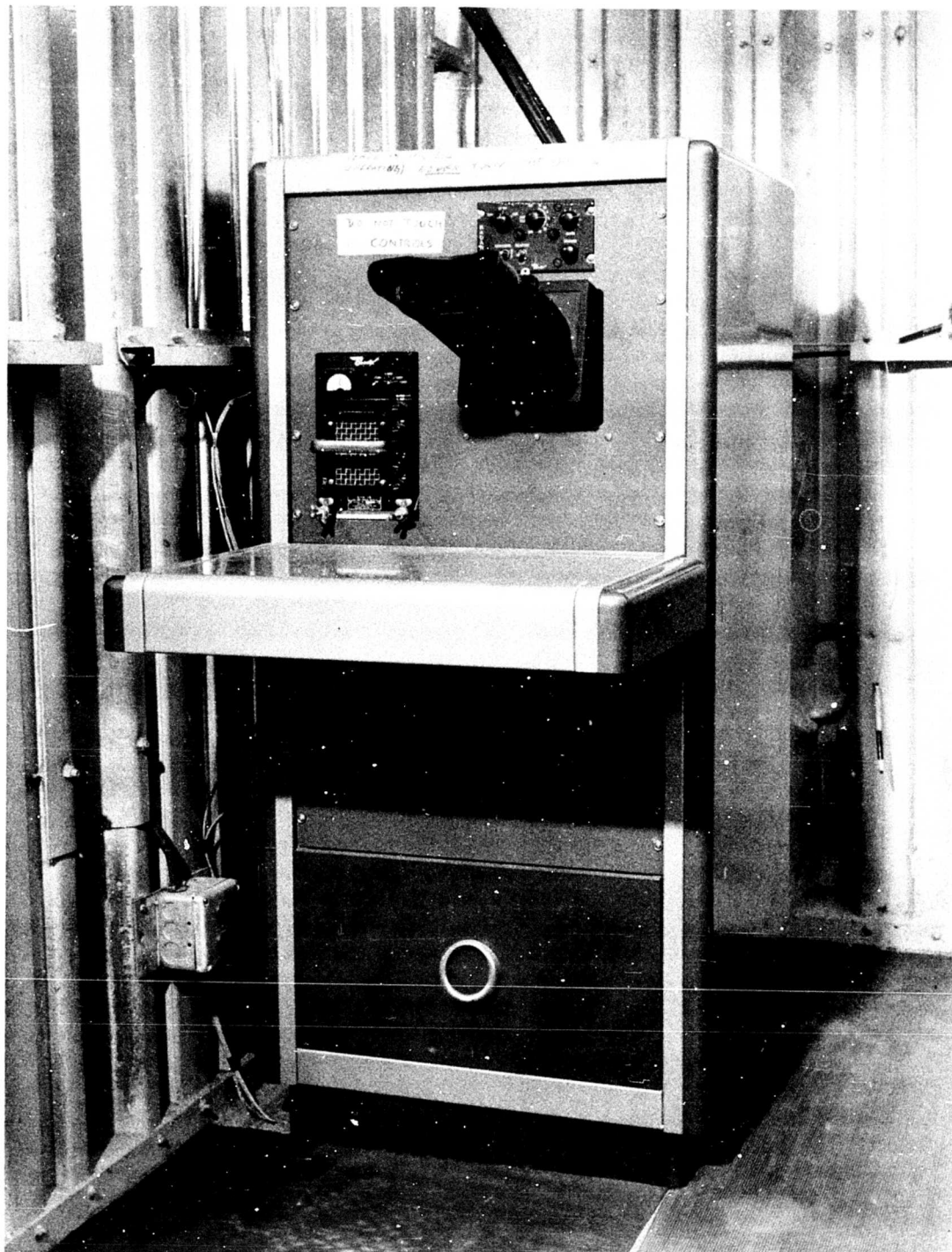

Fig. 1.2 - Weather radar console

The Bhangmeters were located at the Eniwetok and Bikini Control Points. Each installation included two Mark V and two Mark VI Bhangmeters housed in a single rack. Photoheads were mounted on the photo tower next to the Control Point.

On four of the thirty-one shots instrumented for Bhangmeter recording, the light intensities were insufficient to trigger the units, and no results were obtained. Time-to-light minimum on twenty-seven shots was reported directly to the participating laboratories shortly after each shot.

## Chapter 2

### TIMING AND FIRING INSTALLATIONS

#### 2.1 ENIWETOK TIMING SYSTEMS

Control equipment for Yvonne, Janet, and Glenn timing systems was located in the Eniwetok Control Point (Station 71) at the northern end of Elmer. A four-section control console contained control panels for each timing system and for communications. The Eniwetok timing and firing installations described below are shown in block diagram form in Fig. 2.1.

The Yvonne system, intended primarily for the smaller LASL detonations, served zero sites on Yvonne and off-shore barge sites. A timing station on Yvonne (Station 77.01) distributed signals to experimenters on or near Yvonne, including the Mack and Wilma photo towers. This station contained two identical sets of equipment since it was also employed in the Janet timing system. Signals were also distributed from the CP to local users on Elmer and nearby islands.

The larger shots of Eniwetok Atoll were detonated by the Janet timing system at two separate zero locations: barge sites near Janet and a surface site on Gene. Separate arm, fire and monitor lines were run to the two locations and selection of either channel was controlled by a switch in the Janet timer rack at the CP.

The Janet system included three distribution stations: Station 77.01 on Yvonne, 77.02 on Janet, and 77.03 on Irene. Station 77.02 distributed signals to experimenters on Janet and to the photo bunker on Alice. Shot Koa was the only shot detonated on Gene; special experiments for this shot were served by Station 77.03, which was disconnected after the shot.

Each system had independent timing equipment, including sequence timer and signal decoder; however, both systems made joint use of one automatic recorder assembly for voice-time announcements and one radio-tone signal system to supplement hardwire signal distribution.

The Glenn system, used exclusively for the underwater shots, was completely independent of the other systems, with separate voice-time and radio-time equipment. The basic timing equipment was identical to the other system but, in place of hardwire distribution, relay closures from the CP signal decoder keyed radio-tone transmitters which supplied both timing signals for general usage and firing signals to the devices. Since the major experimenter instrumentation for the underwater shots was located on shipboard, a signal distribution station was set up on each ship. These stations converted the radio signals to hardwire signals which were then distributed to the experimenters located on each ship.

#### 2.2 ENIWETOK CONTROL POINT

Timing equipment at Station 71 (Eniwetok CP) included a four-section control console and thirteen 7-ft racks of control equipment for the three timing and firing systems. The components of each rack are outlined below:

##### Rack No. 1: Power Rack (Fig. 2.2)

This rack grouped most of the power equipment required for control station operation. The top panel contained a twin-unit Esterline-Angus voltage recorder for monitoring 115 v-ac

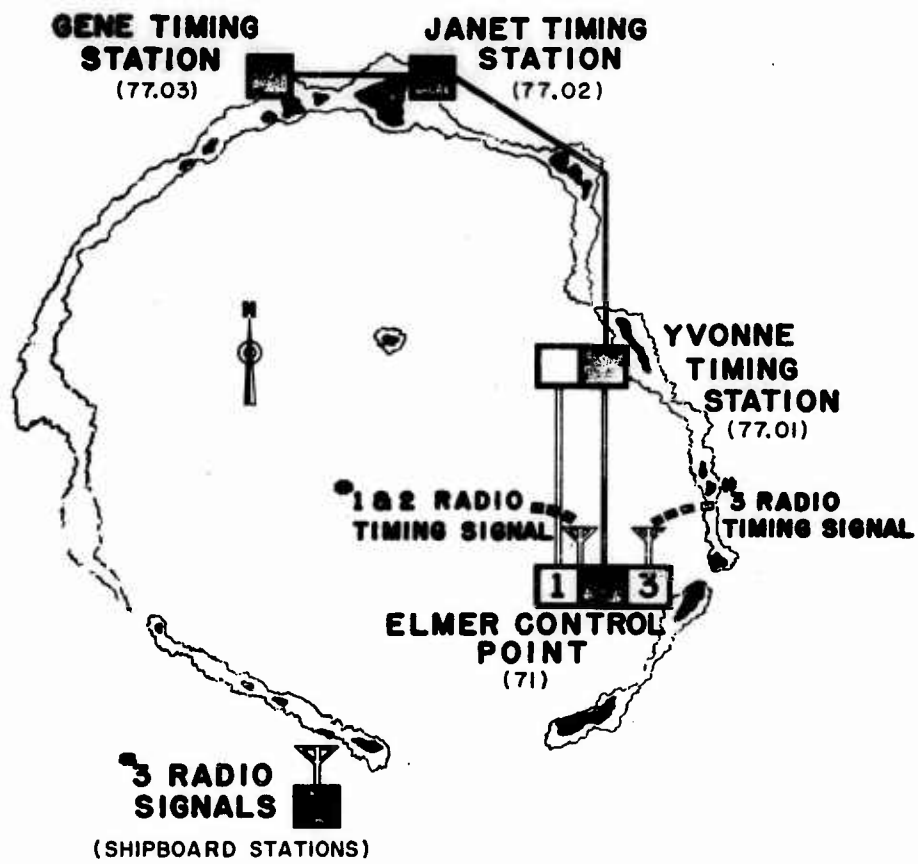

Fig. 2.1 - Eniwetok timing systems

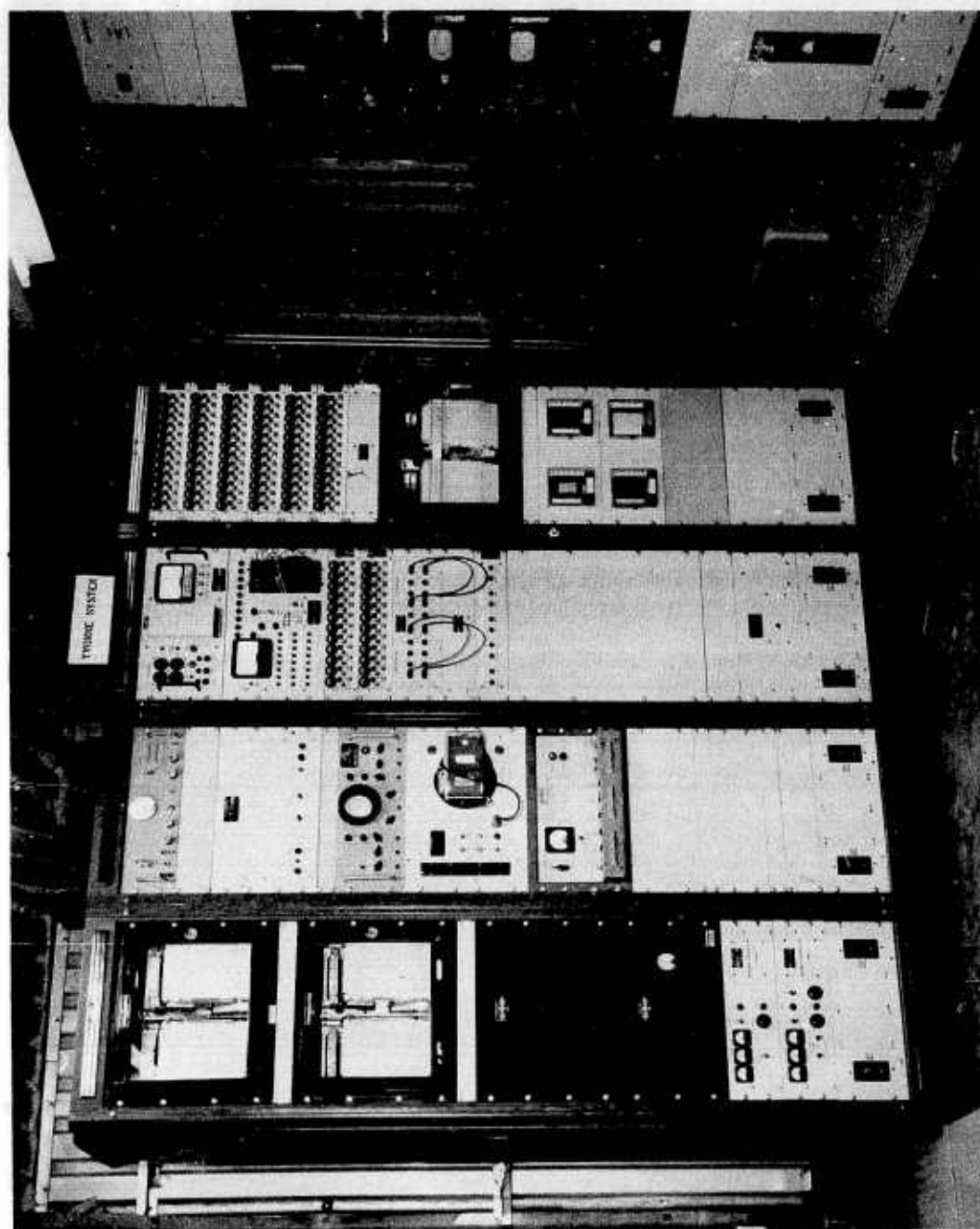

Fig. 2.2 - Power, world-time, and Yvonne system racks

and 120 v-dc power. A similar unit in the next panel monitored 24 v-dc power. These units provided a continuous record of fluctuations in control station power. Below were two panels containing a General Radio 1000-cycle Multivibrators and Power Supply Unit, Type 1102A, and a General Radio 100-kc Piezo-Electric Oscillator, Type 1101-A. The remainder of the rack housed two EG&G Battery Chargers, Type PS-4 and PS-3, and the a-c and d-c rack power switches.

Rack No. 2: World Time Rack (Fig. 2.2)

At the top of this rack was a Shasta Model 1201 Radio Receiver and below it the EG&G World-Time Synchronizer, Type SN-1, and a Waterman Rakscope, Model S-12-B. The next panel contained the EG&G World-Time Clock, Type TD-3, and its associated camera. The lower panels contained a Brush BL-809 Regulated-Frequency Power Supply and the a-c and d-c rack power switches.

Rack No. 3: Yvonne Timer Rack (Fig. 2.2)

The master rack for the Yvonne system contained an EG&G Stepping-Switch Sequence Timer, Type SA-4; a Signal Decoder, Type SA-5A, for local signals; and two 12-meter Signal Distribution Control Units, Type SA-2. Below these units were an Interlock Relay Patch Panel, Type RE-1, and a Relay Panel, Type RE-2. The next panel in this rack contained the decoder "ready" indicator lights for each timing station, three Hammarlund DRU-2 Tone Receivers, and one Hammarlund DRU-12 Tone Receiver. Each of these receivers telemetered two channels. The remainder of the rack housed an Emergency-Stop Relay Panel, Type RE-4, and the a-c and d-c rack power switches.

Rack No. 4: Yvonne Distribution Rack (Fig. 2.2)

This rack was primarily a signal distribution rack for the Yvonne system. The six signal distribution control units, Type SA-2, at the top of the rack contained a total of 72 meters. Below was a Relay Panel, Type RE-2, and an Esterline-Angus 40-pen recorder which recorded the transmission of each timing signal and the power conditions at each zero point and at the timing stations. The next four panels contained six Bristol miniature strip-chart recorders for the use of other experimenters and the a-c and d-c rack power switches.

Rack No. 5: Voice-Time Recorder Rack (Fig. 2.3)

This rack contained the Ampex voice-time equipment used jointly by the Yvonne and Janet systems. At the top, Relay Switch Panel RE-5 controlled operation of the Ampex equipment. Mounted in the remainder of the rack were the Tape Transport Assembly, Model 5700, a recorder for the voice-time countdown and a recorder for the 60-cycle reference signal, comprising the Ampex Model 350 Two-Channel Recorder, a Playback Demodulator, Model 391, a 60-cycle Amplifier, Model 375, and the a-c and d-c rack power switches.

Rack No. 6: Janet Timer Rack (Fig. 2.3)

The components of this rack were identical to those of the Yvonne Timer Rack (Rack No. 3) except for a switch to select telemetered tone signals from either the Janet or the Gene zero sites. The rack contained the following:

EG&G Stepping Switch Sequence Timer, Type SA-4  
EG&G CP Signal Decoder, Type SA-5A  
Two EG&G Signal Distribution Control Units, Type SA-2  
Interlock Relay Panel, Type RE-1  
Decoder Ready Indicator

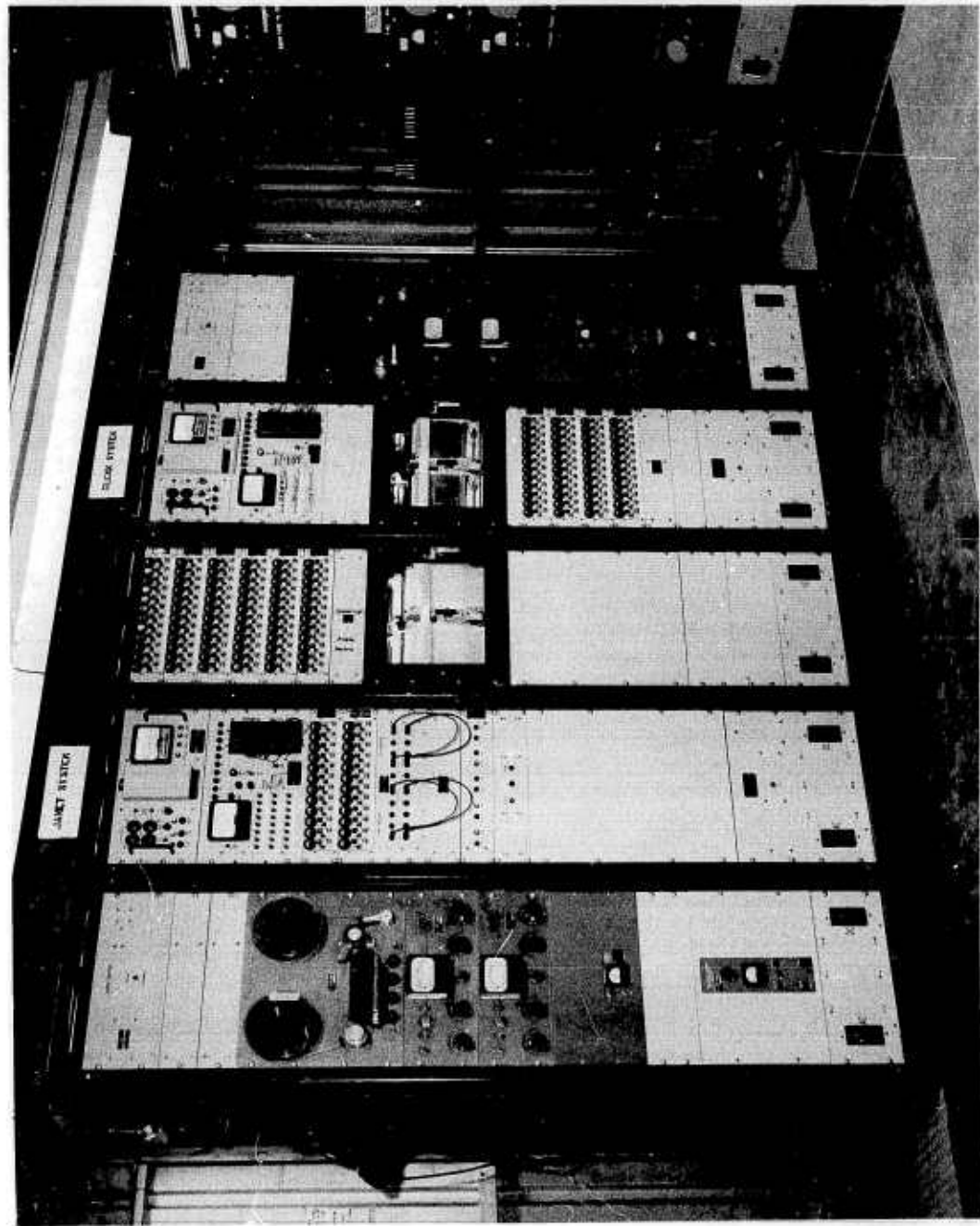

Fig. 2.3 - Janet and Glenn system racks

Janet-Irene zero-site switch  
Four Hammarlund DRU-2 Tone Receivers  
Emergency-Stop Relay Panel, Type RE-4  
A-c and d-c rack power switches

Rack No. 7: Janet Distribution Rack (Fig. 2.3)

This rack controlled the distribution of timing signals for the Janet system. Six signal distribution control units were located at the top; below were an Esterline-Angus 40-pen recorder, five Hammarlund DRU-2 Tone Receivers, and an ac-dc power switch panel.

Rack No. 8: Glenn Timer Rack (Fig. 2.3)

This rack combined the timing and the hardwire distribution equipment for the DOD Glenn system. At the top of the rack was the Stepping Switch Sequence Timer, SA-4; below, the CP Signal Decoder, Type SA-5A; an Esterline-Angus 40-pen recorder; four signal distribution control units; a relay panel; an emergency-stop relay panel; and an ac-dc switch panel.

Rack No. 9: Voice Time Recorder Rack (Fig. 2.3)

The Ampex voice-time equipment for the Glenn system was located in this rack. The components of this rack were identical to the recorder rack for the Janet and Yvonne systems (Rack No. 5).

Racks 10, 11, and 12 contained the radio-tone timing and firing equipment used by all three Eniwetok systems and control equipment for the voice-time and communications nets. Radio-Time and Voice-Time No. 1 systems were used by both the Janet and Yvonne timing systems. Radio-Time and Voice-Time No. 2 systems and the firing-tone system were used for the Glenn timing system. Rack components are listed below.

Rack No. 10: Radio-Time No. 1 Rack (Fig. 2.4)

Motorola Radio-Time No. 1 remote control unit for radio-time signal transmitter  
Radio-Time No. 1 tone generator  
Remote control unit for firing-tone transmitter  
TU-1 communications net receiver  
Firing-tone generator  
Radio-Time No. 1 Motorola 12-tone a-c receiver  
Ac-dc switch panel

Rack No. 11: Radio-Time No. 2 Rack (Fig. 2.4)

Motorola remote control unit for Radio-Time No. 2 transmitter  
Radio-Time No. 2 tone generator  
Motorola 12-tone a-c receiver for monitoring Radio-Time No. 2  
Zero-site telemetering receiver  
Telemeter Decommutator, Model 3620-D12  
Voice-Time No. 1 monitoring receiver  
Collins power supply  
Ac-dc switch panel

Rack No. 12: Communications Rack (Fig. 2.4)

Howler Receiver to monitor remote zero-rack power or arm clock  
Voice-time No. 2 monitoring receiver

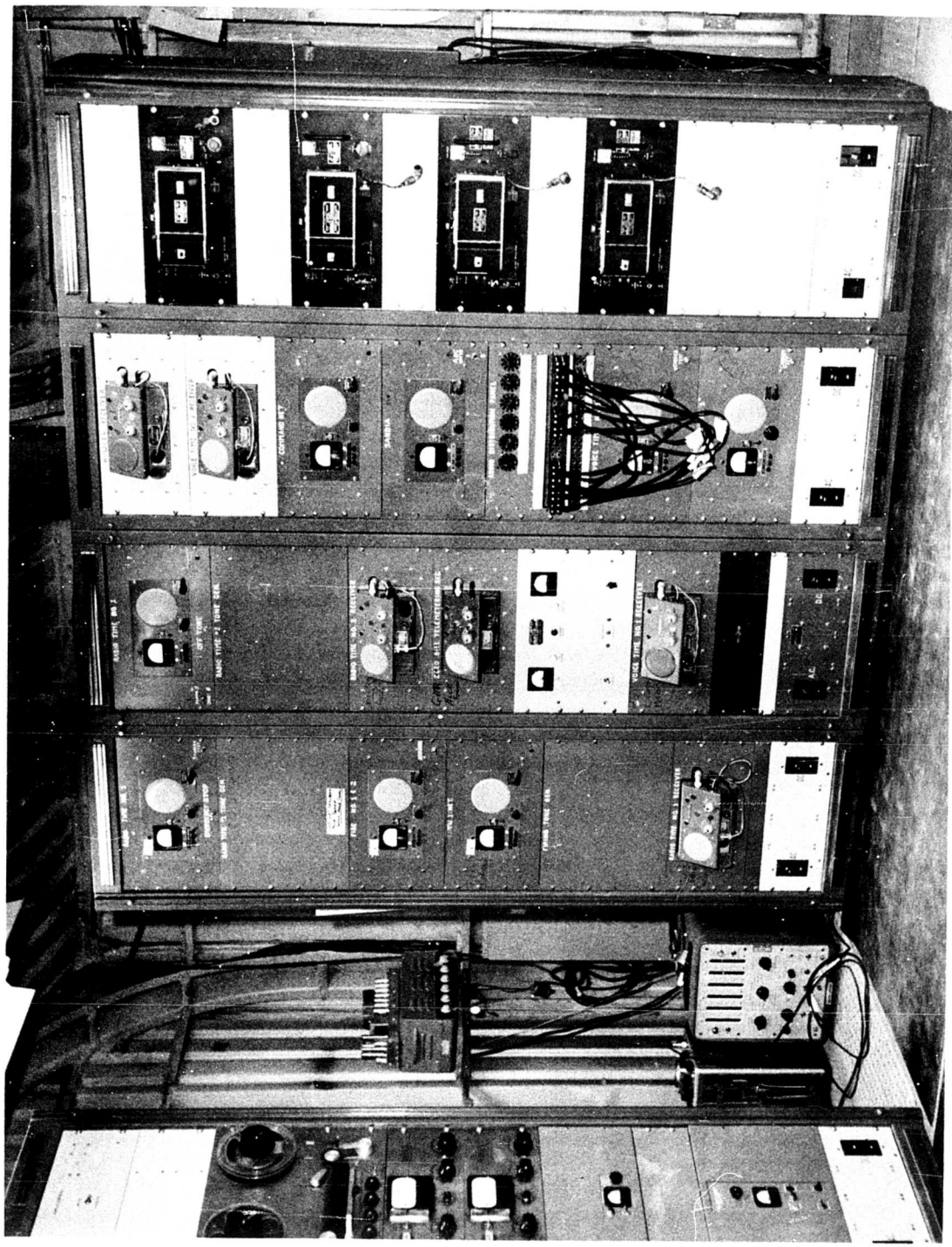

Fig. 2.4 - Radio and Bhangmeter racks

Command communications net  
Sandia communications net  
Audio-distribution patch panel  
Voice-time No. 1 remote control unit  
Voice-time No. 2 remote control unit  
Ac-dc switch panel

Rack No. 13: Bhangmeter Rack (Fig. 2.4)

This rack contained four Bhangmeter recording sets, each with a polaroid-back camera mounted on the front. There were two MK V Bhangmeters and two MK VI Recording Sets. At the bottom of the rack was an ac-dc switch panel.

### 2.3 BIKINI TIMING SYSTEMS

The Tare and Charlie systems, which detonated the UCRL devices at Bikini Atoll, were operated from the Control Point (Station 70) on Nan. The systems were independently controlled, although they shared a common voice-time system. A block diagram of Bikini timing and firing installations is shown in Fig. 2.5.

The Tare system was employed on three of the smaller UCRL shots which were detonated on barges near the tip of Tare Island. A signal distribution station on Oboe (Station 74.01) served experimenters on the nearby islands of the Tare complex in addition to the William photo tower.

The Charlie system, which served zero sites near Charlie and Fox for the larger UCRL shots, included three signal-distribution stations, Station 74.01 (originally a triple station), Station 76 on George, and Station 78.01 on Charlie. Signals from the CP were distributed locally on Nan and to the How photo tower. Stations 76 and 78.01 supplied signals to experimenters in their respective localities depending on which zero area was involved. Toward the end of the tests at Bikini, the equipment in Station 78.01 was installed in Station 75.02 on How. The latter station had been deactivated when the missile system was removed to Johnston Island.

The Bikini timing and firing system included the capability for transmitting radio-tone timing signals; however, the radio-tone system was not put into use since all experimenters were adequately served by the hardwire system.

### 2.4 BIKINI CONTROL POINT

A three-section control console and thirteen 7-ft racks of equipment comprised the timing and firing installation in the Control Point building. The two Bikini systems were nearly identical to the Yvonne and Janet systems at Eniwetok Atoll. Figures 2.6 through 2.8 include the How missile installation, but the rack descriptions below reference only the components remaining after the missile system was removed.

Rack No. 1: Power Rack (Fig. 2.6)

Twin-unit Esterline-Angus recording voltmeter for monitoring 115 v-ac and 120 v-dc power  
Esterline-Angus recording voltmeter for 24 v-dc and a spare unit  
General Radio Multivibrators and Power Supply, Model 1102A  
General Radio Piezo-Electric Oscillator, Model 1101A  
EG&G Battery Charger, Type PS-4 (120 v)  
EG&G Battery Charger, Type PS-3 (60 v and 24 v)  
Ac-dc rack power switch panel

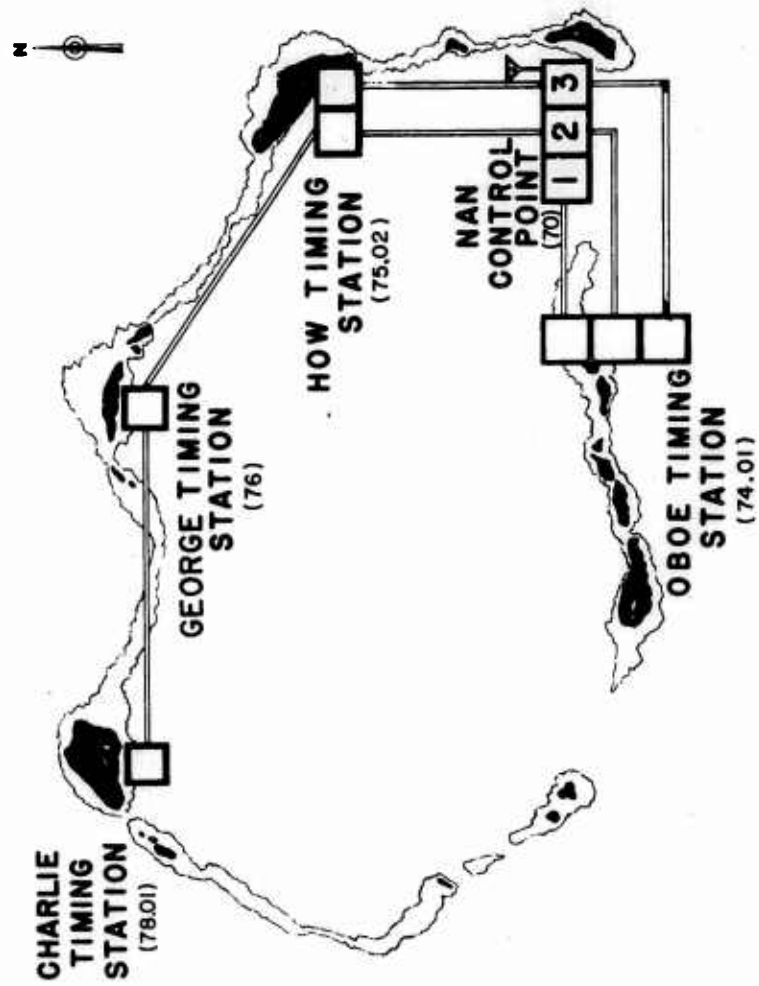

Fig. 2.5 - Bikini timing systems (including How missile system)

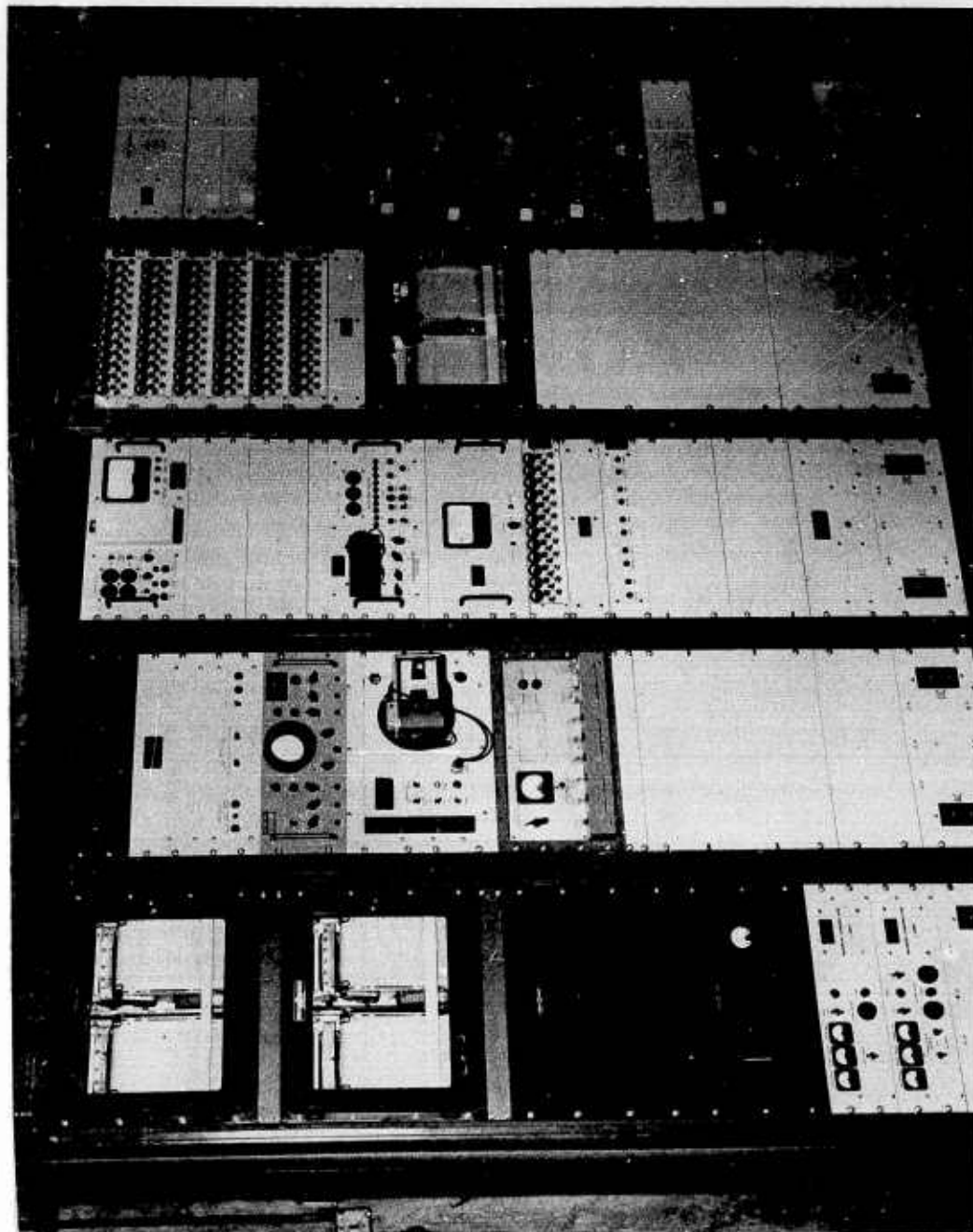

Fig. 2.6 - Power, world-time, and How system racks

Rack No. 2: World Time Rack (Fig. 2.6)

Because of difficulties encountered in receiving the time signal from WWVH, Honolulu, at the CP, the radio receiver was removed from this rack. The space at the top of the rack was occupied by a single speaker, tied into the audio distribution patch panel in Rack No. 14. The time signal was received either from the Holmes and Narver communication net or from a spare Hammarlund radio receiver located outside the CP. At the audio distribution panel, the signal from either source was transmitted to the speaker and to the Waterman Rakscope, Model S-12-B, located below the speaker.

The remaining panels in this rack housed the EG&G World Time Clock, Type TD-3, and associated camera, a Brush Regulated-Frequency Power Supply, Model BL-809, and the ac-dc rack power switches.

Rack Nos. 3 and 4 (Fig. 2.6)

Rack No. 3 contained only the EG&G Divider Synchronizer unit, Type SN-1. The remaining blank panels in this rack and the blank panels in Rack No. 4 had been occupied by the timing and distribution equipment for the missile shots.

Rack No. 5: Voice-Time Recorder Rack (Fig. 2.6)

A relay switch panel, Type RE-5, was located at the top of the rack. Below were two Ampex Power Supplies, Model 3741, for the recorder. The remaining panels contained the Tape-Transport Assembly, Model 5700, the Ampex Model 350 Two-Channel Recorder consisting of an audio track recorder and a control track recorder, an Ampex Playback Demodulator, Model 391, and a 60-cycle Amplifier, Ampex Model 375. At the bottom were the a-c and d-c rack power switches.

Rack No. 6: Charlie System Timer Rack (Fig. 2.7)

EG&G Stepping-Switch Timer, SA-4  
CP Signal Decoder, SA-5A  
Two Signal Distribution Control Units, Type SA-2  
Interlock Relay Patch Panel, RE-1  
Relay Panel, RE-2  
Decoder Ready Indicator, RE-3, for the Nan, George and Oboe decoders

Below were five Hammarlund DRU-12 Tone Receivers providing ten channels; an Emergency-Stop Relay Panel, RE-4; and an ac-dc rack power switch panel.

Rack No. 7: Charlie System Distribution Rack (Fig. 2.7)

This rack contained six Signal Distribution Control Units, Type SA-2; a Relay Panel, Type RE-2; an Esterline-Angus 40-pen recorder; five two-channel Hammarlund DRU-12 Tone Receivers; and an ac-dc rack power switch panel.

Rack No. 8: Telemeter Rack (Fig. 2.7)

The top of this rack housed a circular chart, Bristol's Metameter, Model 3M1M500, for recording meteorological conditions at barge sites. Located below were two Bristol miniature strip charts for recording temperature and humidity at UCRL Station 2250. Seven two-channel Hammarlund DRU-12-5 Receivers were mounted in the remaining panels above the ac-dc rack power switch panel.

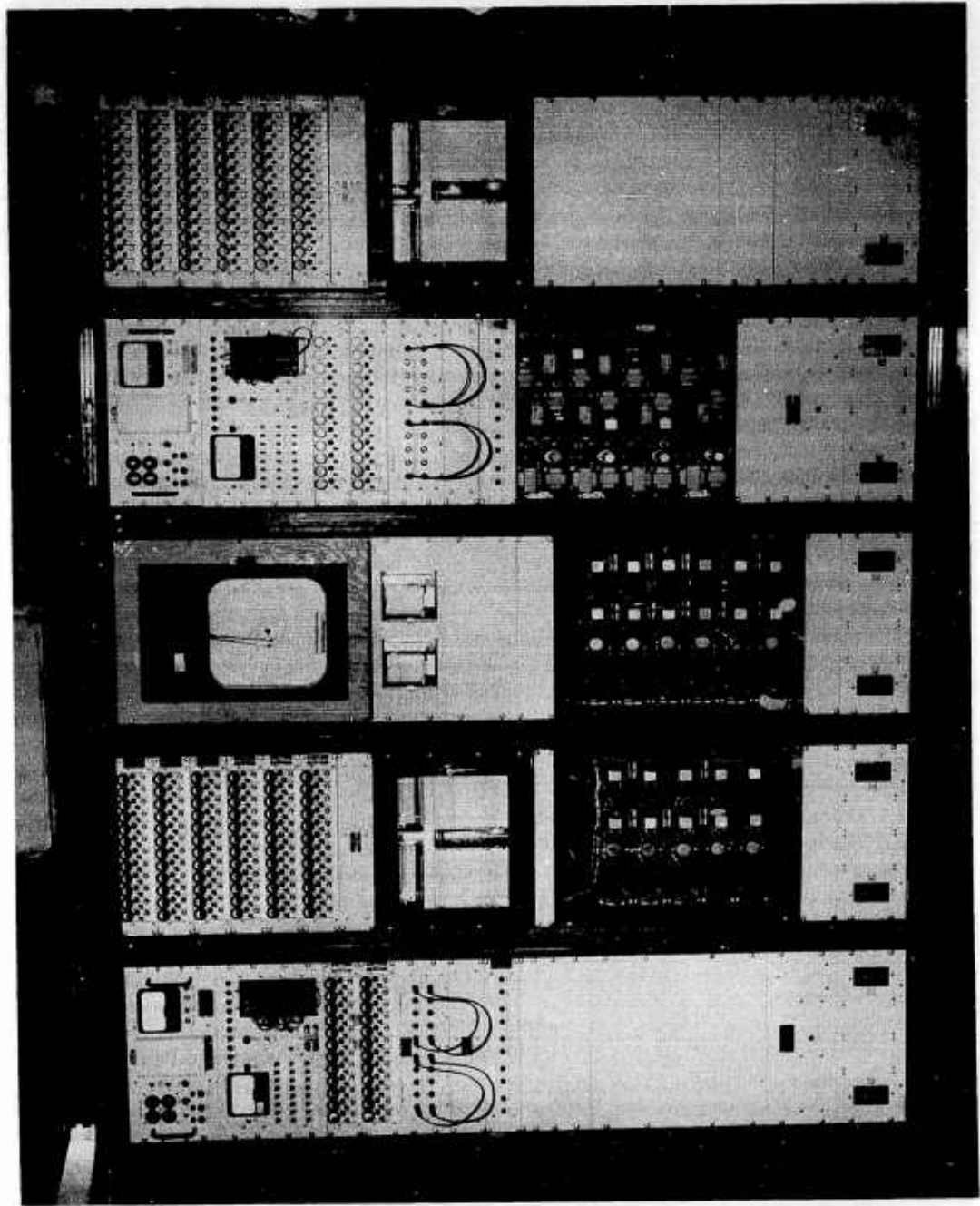

Fig. 2.7 - Charlie and Tare system racks

Rack No. 9: Tare System Timer Rack (Fig. 2. 7)

The timer rack for the Tare system was nearly identical to that for the Charlie system. Its components are listed below:

Stepping Switch Sequence Timer, Type SA-4  
CP Signal Decoder, Type SA-5A  
Two Signal Distribution Control Units, Type SA-2  
Interlock Relay Patch Panel, RE-1  
Relay Panel, RE-2  
Decoder Ready Indicator, RE-3, for the Nan and Oboe decoders  
Four Hammarlund DRU-4A Tone Receivers  
Emergency-Stop Relay Panel  
Ac-dc rack power switch panel

Rack No. 10: Tare Distribution Rack (Fig. 2. 7)

The following units comprised the distribution rack for the Tare system:

Six Signal Distribution Control Units, Type SA-2  
Relay Panel, RE-2  
Esterline-Angus 40-pen recorder  
Two Hammarlund DRU-2 Receivers and a Hammarlund DRU-12 Receiver  
Ac-dc rack power switch panel

Rack No. 11: Bhangmeter Rack (Fig. 2. 8)

Four Bhangmeters were mounted in this rack. There were two Bhangmeters Mark V and two Recording Sets Mark VI. An ac-dc rack power switch panel was at the bottom of the rack.

The radio communications racks, Racks 12 through 14 in Fig. 2. 8, were originally set up to provide a dual-capability system of radio-time signals and voice-time nets for three timing systems; however, removal of the missile system also entailed removal of Radio-Time No. 1 and Voice-Time No. 1 systems.

Voice-Time No. 2 system was shared by the Charlie and Tare systems.

Rack No. 12

This rack contained the Motorola control consolette, radio-time monitoring receiver and tone generator for the Radio-Time No. 2 system and an ac-dc power switch panel.

Rack No. 13

Rack No. 13 contained the monitor for the Voice-Time No. 2 system, an Air Force communications-net monitoring receiver and speaker panel, and a Bogen Amplifier (Model 1. 6A). The lower section of the rack contained two Collins power supplies and an ac-dc rack power switch panel.

Rack No. 14

This rack housed the control consolette for the Voice-Time No. 2 net and an identical spare unit. Below was the Audio Distribution Panel for patching the voice countdown into the user nets.

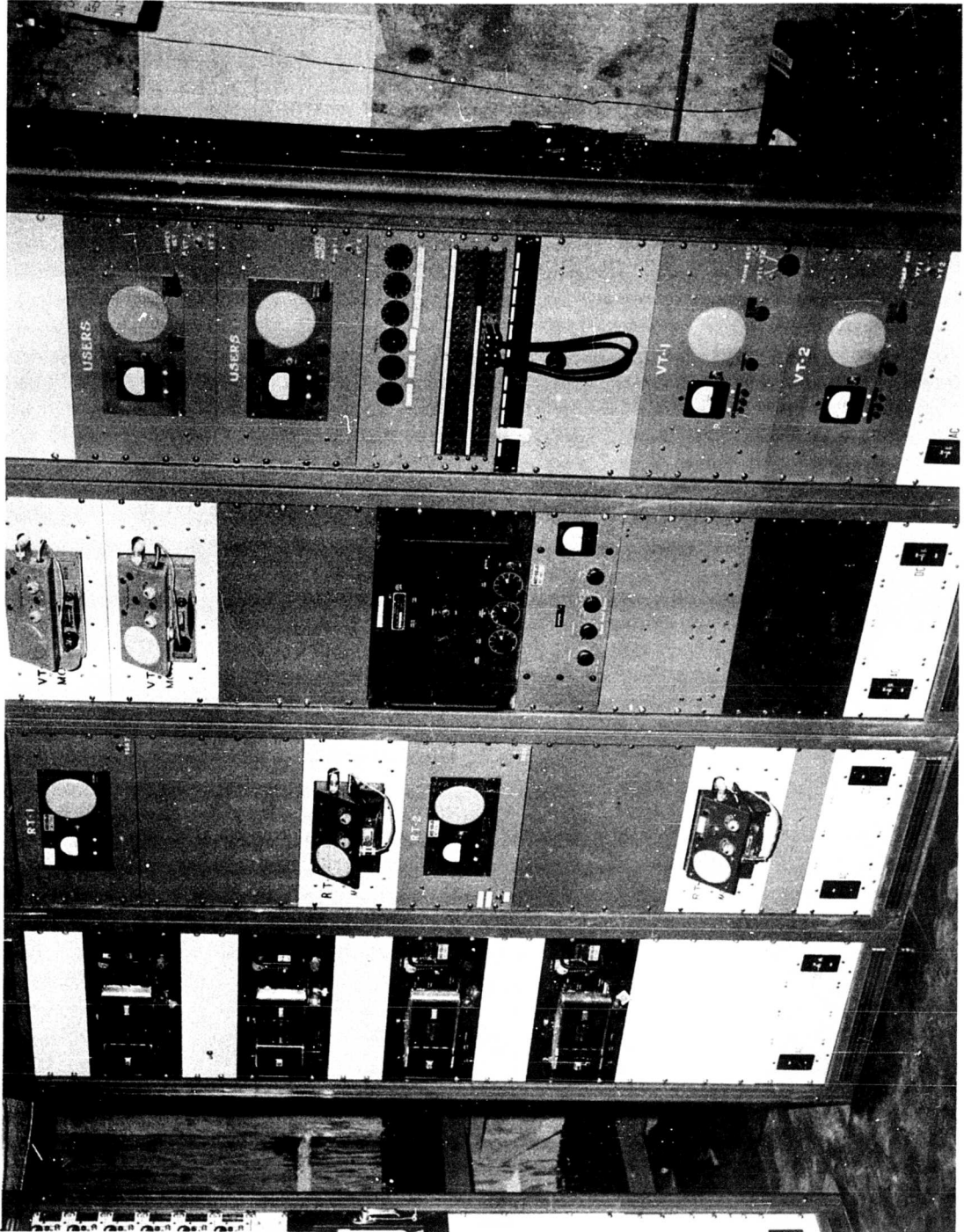

Fig. 2.8 - Bhangmeter and radio racks

## 2.5 TIMING SIGNAL DISTRIBUTION STATIONS

The function of the timing station was to isolate signals from the master timing system and distribute them locally to the individual users. Timing signals were distributed both from signal distribution units in the Control Point and from timing signal distribution stations which were set up in several locations around Eniwetok and Bikini Atolls and on ships in the Eniwetok lagoon. Each of the timing systems included one or more of these stations. Table 2.1 is a list of the timing systems and their respective distribution stations.

### 2.5.1 Island Stations

All stations were of identical design, each consisting of two 7-ft equipment racks similar to those shown in Fig. 2.9. A typical rack layout is described below:

Rack No. 1 contained three 12-meter signal distribution panels; an Esterline-Angus 40-pen recorder; an EGG-net transceiver; a TD-5 Sequence Timer for special zero-site functions; a Battery Charger, Type PS-3; and an ac-dc switch panel.

Rack No. 2 contained three 12-meter distribution panels; a Signal Decoder, Type SA-5; an interlock relay panel; another 12-meter signal distribution panel; and four Hammarlund DTU-1 Tone Transmitters. Line connections to and from the timing station were made on a cable-termination board mounted near the racks. To facilitate connection, each cable was identified by a placard at the termination point.

To protect the timing station equipment from voltage surges resulting from a detonation, a line-filter box was inserted into the lines from the timing station to the zero sites.

Connection of experimenter signal lines to the signal distribution panels were made through a box mounted on the side of one of the racks.

Timing station power came from a bank of lead-acid batteries arranged so as to provide 24 v-dc. A-c power was supplied either from deisel generators located on the island or, as in Station 77.02, from batteries and an a-c converter.

### 2.5.2 Shipboard Timing Stations

The DOD (Glenn) timing system transmitted timing signals by radio to five shipboard distribution stations. These ships, which are listed below, contained the bulk of experimenter equipment for Shots Wahoo and Umbrella:

DD-474	USS Fullam
DD-592	USS Howorth
DD-593	USS Killen
YFNB-12	
EC-2	

Radio-tone signals from the CP activated the equipment in these stations, and timing signals were distributed by wire to the users on the ships.

Components of a typical shipboard distribution station are listed below. The equipment was housed in two 7-ft racks. Rack No. 1 contained two Zero Fiducial Receivers, Type N3620-D19, an EGG-net transceiver, two Motorola 12-Tone Receivers, a General Electric a-c voltage monitor, and an ac-dc rack power switch panel.

Table 2.1 - TIMING SIGNAL DISTRIBUTION STATIONS

Timing System	Station No.	Location
<u>Eniwetok Atoll</u>	71 (Control Point)	Elmer
Yvonne Timing System	77.01*	Yvonne
Janet Timing System	77.01*	Yvonne
	77.02	Janet
	77.03#	Irene
Glenn Timing System	Shipboard	USS Fullam (DD-474)
	Shipboard	USS Howorth (DD-592)
	Shipboard	USS Killen (DD-593)
	Shipboard	YFNB-12
	Shipboard	EC-2
<u>Bikini Atoll</u>	70 (Control Point)	Nan
Tare Timing System	74.01**	Oboe
Charlie Timing System	74.01**	Oboe
	75.02##	How
	76##	George
	78.01##	Charlie

\*Station 77.01 was a double station.

#Station 77.03 was disconnected after Shot Koa.

\*\*Station 74.01 was a triple station until the How missile system was removed.

##Stations 75.02 and 78.01 were decommissioned when the missile system was removed to Johnston Island; late in the operation, however, the equipment at Station 76 was installed in Station 75.02.

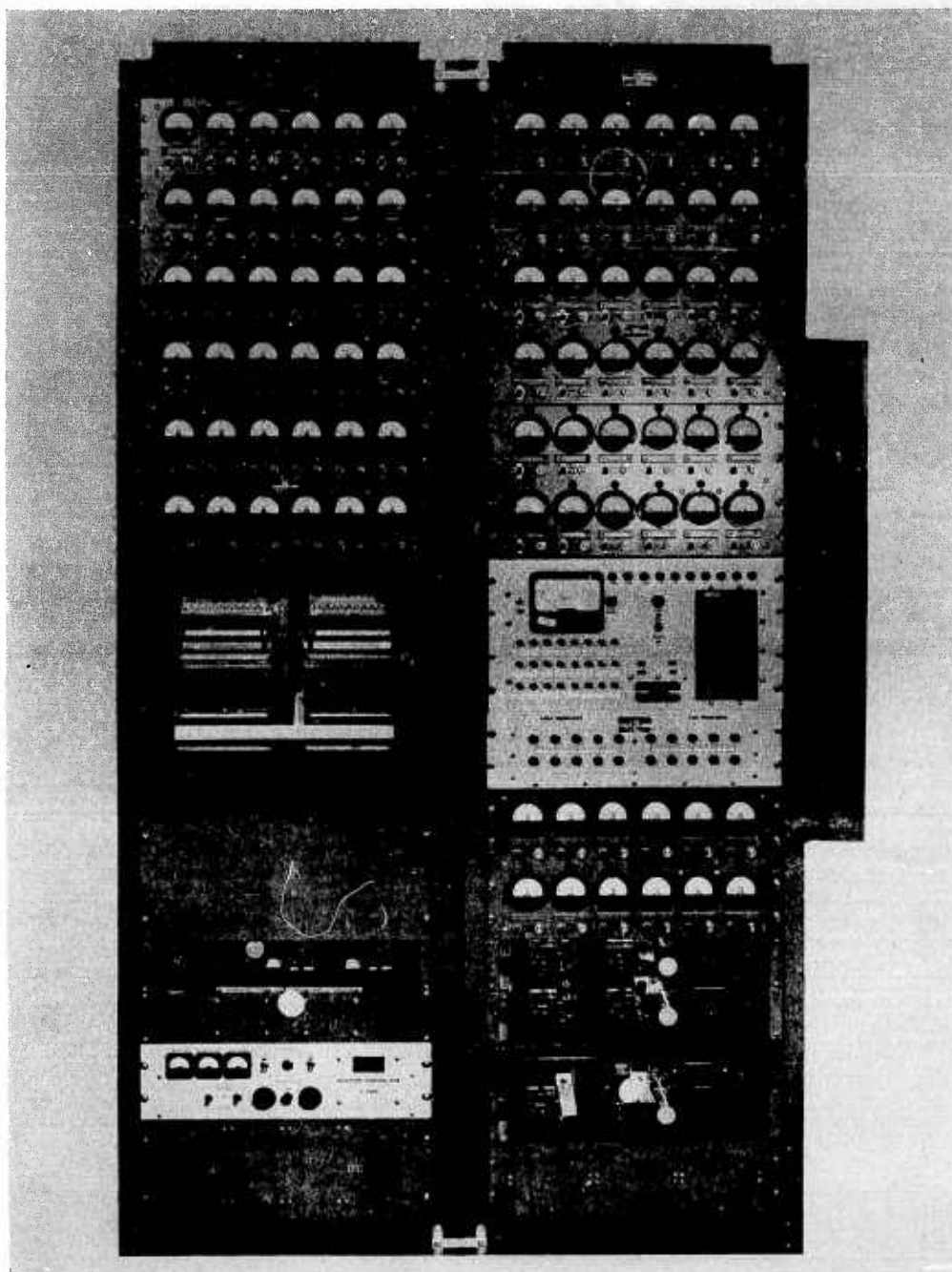

Fig. 2.9 - Typical timing station

Rack No. 2 contained three 12-meter signal distribution panels, an Esterline-Angus 20-pen recorder, an EG&G Battery Charger, Type PS-3, and an ac-dc rack power switch panel.

The two Motorola 12-tone receivers picked up the radio-tone signals transmitted from the CP. Antennas were mounted on the mast. The receivers operated in parallel, one serving as a back-up in case of failure of the other. The radio-tone signals were converted to relay closures and the signal was transmitted by wire through the signal distribution panels to user relays. The ten signals transmitted by radio were as follows:

-60 min.	-15 sec
-30 min.	-5 sec
-15 min.	-1 sec
-5 min.	zero test
-1 min.	+1 sec OFF

The zero-test signal was used only on dry runs. The actual zero signal was transmitted over the zero-fidu net. All functions were shut off at +1 sec. To insure positive cut-off, the two tone receivers operated in series when the "off" tone was transmitted.

A-c power was supplied by the shipboard power system. D-c power was obtained from lead-acid batteries located near the racks.

## Chapter 3

### BOXER INSTALLATION

#### 3.1 CONTROL CENTER

The control room on the USS Boxer contained all the timing and firing equipment for the high-altitude balloon shot (Fig. 3.1). The system included a control console, a timer rack, a distribution rack, and a radio rack. The sequence timer for this installation was the automatic airdrop timer from Plumbbob. A detailed description of the airdrop timer is given in the timing and firing report for Operation Plumbbob (WT-1494). Three 250-watt Motorola transmitters were also located in the control room.

The timing sequence began at -30 minutes. Signals from -30 min. to -1 min. were manually initiated by means of toggle switches on the control console. No more signals were sent until a verbal "go ahead" was received from Sandia, whereupon the automatic timing sequence started. The signals transmitted were as follows:

<u>Manual</u>	<u>Automatic</u>
-30 min.	-30 sec
-15 min.	-15 sec
-1 min.	-5 sec
	-2.5 sec
	-1 sec
	zero

From the distribution panels, signals were sent by wire to the cameras and to users located on board the ship. These signals were also transmitted by radio tone. Special arm and fire signals were sent directly by wire to EG&G relays in the Sandia trailer located on the flight deck. These signals were as follows:

-12 sec	Arm 1A
-8 sec	Arm 1B
-9 sec	Arm 2A
-8 sec	Arm 2B
-3 sec	Fire A
Zero	Fire B

Relay closures from the manual signal switches and from the airdrop timer were brought together at a terminal strip and tied into the radio-tone system. Radio-tone timing signals were transmitted to the two airborne camera installations. This transmitter operated at a frequency of 157.43 Mc, at a nominal power of 250 w.

The voice-time countdown was given live until -30 sec when the tape-recorded countdown was broadcast in synchronization with the timing signals from the airdrop timer. The 30-w section of another 250-w transmitter was used for special voice-time signals. The audio was also fed into the audio distribution system on board ship, which included the local public-address system, the 243-Mc AOC net, and the Sandia and Bendix audio circuits. This transmitter operated at a frequency of 157.89 Mc. The voice-time announcements were also broadcast to Nan at a frequency of 154.57 Mc.

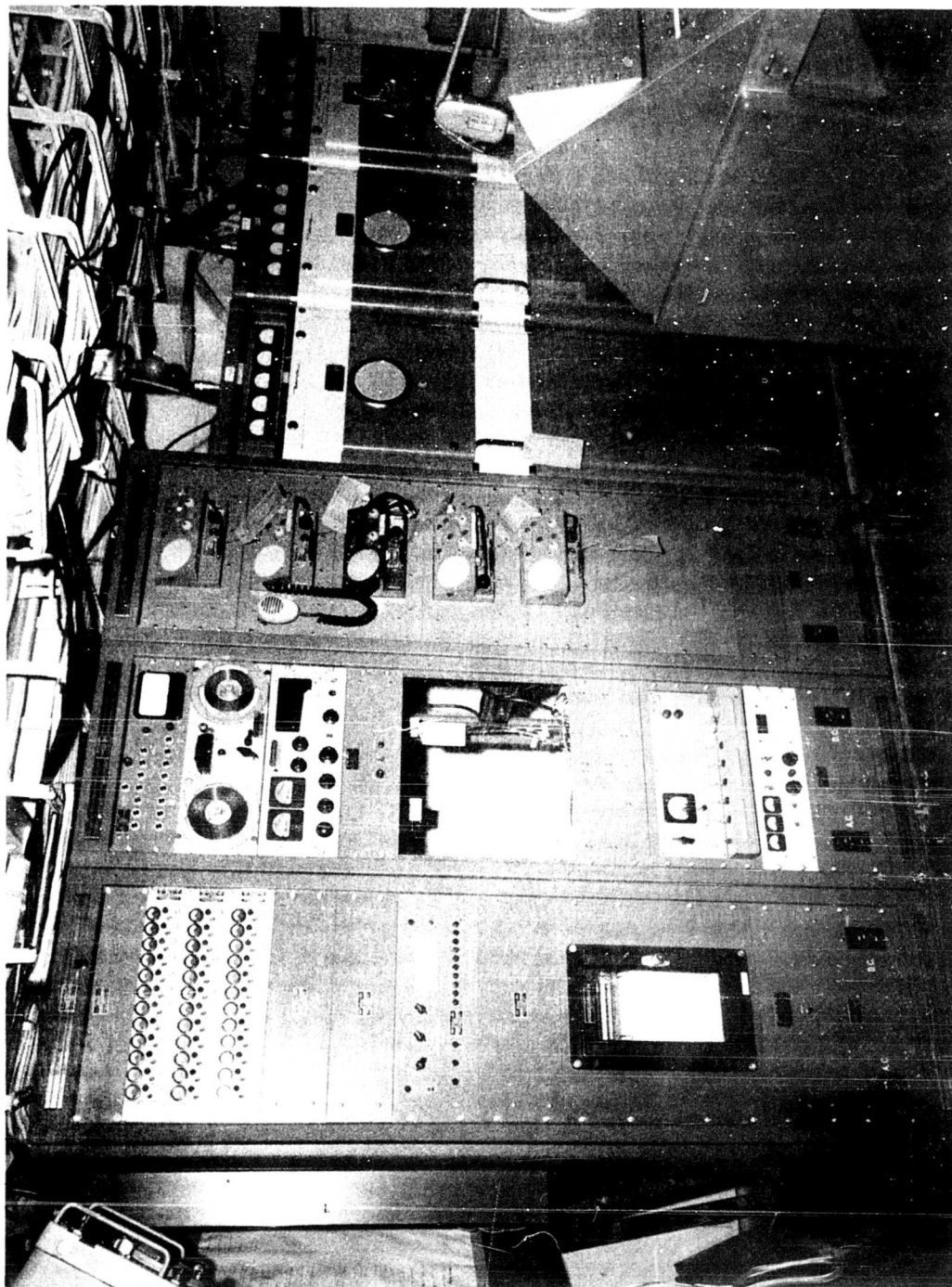

Fig. 3.1 - Control room, USS Boxer

World-time equipment was not included in the Boxer installation since it was expected that the burst could be seen from either Eniwetok or Bikini Atoll; however, the detonation occurred out of range of the world-time fidu markers, and no record was obtained.

### 3.2 RACK DESCRIPTION

The components of each rack are listed below:

#### Rack No. 1

EG&G Relay Panel, Type RE-7  
Three EG&G Signal Distribution Control Units, Type SA-2  
Two function relay panels for the airdrop timer  
EG&G Airdrop Stepping-Switch Sequence Timer  
Power supply for airdrop timer  
Esterline-Angus 20-pen strip chart recorder  
Emergency-Stop Relay Panel, Type RE-4  
Ac-dc switch panel

#### Rack No. 2

EG&G Circuit Tester  
Magne recorder Recorder  
Magne recorder Amplifier  
100-cps Generator  
Hammarlund Receiver, Type SP-600  
Speaker Panel  
Terminal Panel  
Brush Power Supply, Model BL-809  
EG&G 60-v and 24-v Battery Charger, Type PS-3  
Ac-dc switch panel

#### Rack No. 3

Voice-time Transmitter (Motorola L43G-1)  
EGG-net 25-watt Transceiver (Motorola L43G-1)  
Radio-time Receiver (Motorola L03G-1)  
Voice-time Receiver (Motorola L03G-1)  
Radio-time Transmitter (Motorola L43G-1)  
Radio-time Termination Panel  
Tone Generator  
Ac-dc switch panel

## Chapter 4

### TIMING SYSTEM COMPONENTS

#### 4.1 CONTROL CONSOLE

The control consoles at Eniwetok and Bikini Atolls were of sectional design and included a control panel for each timing system and for communications. Figure 4.1 is a photograph of the console at the Eniwetok Control Point; from left to right are the control panels for the Glenn system, communications, Janet system, and the Yvonne system. Above the console are three boom-type microphones, one for each of the two voice-time networks and one for the EGG net.

Figure 4.2 is a close-up of a typical control panel. Three banks of indicator lights at the top of the panel monitored standard and special hardwire signals, early and late interlocks, the zero-rack arm, high-voltage, and fire signals, and the radio-time signals. An Electric Time Company clock is mounted in the center of the panel. Immediately below the clock is a counter which indicates time to zero in minutes and seconds.

The sequence-start switch is located to the right of the clock and the system reset button to the left. The sequence-start switch initiates the automatic transmission of the timing signals. If necessary, the timing sequence can be halted at any point and then continued from that point.

Four lights on the left side of the panel indicate the stepping rate of the sequence timer. A 900-cps time tone can be transmitted manually over the voice-time net by means of a push button just below the sequence-start switch. The switch at the lower left was used on dry runs for transmitting a signal to deactivate radio-tone relay units. Operation of the switch at the lower right of the panel opens the firing-line relays, positively preventing detonation of a device if an emergency stop should be necessary. Once the relays have dropped out, a power reset button located in the equipment room must be operated before the timing sequence can be started again.

#### 4.2 WORLD-TIME SYNCHRONIZER

The EG&G World-Time Synchronizer, Type SN-1, provided the means of referencing the timing and firing system to world time. A binary divider system supplied three separate outputs derived from a single frequency standard. Feedback switching networks were employed to synchronize these outputs to the world time audio signal broadcast from official radio stations.

Figure 4.3 is the front panel of the world-time synchronizer. A schematic diagram of the unit is shown in Fig. 4.4. A 10-kc output derived from a stable 100-kc oscillator (General Radio Type 1101A crystal-controlled oscillator) was fed into a series of binary dividers where it was reduced and shaped to provide 2-ppm, 2-pps, and 1-pps outputs. The 100-cps output of the oscillator was divided by a single binary to obtain an output of 50 cps.

The 50-cps output controlled the world time indicator in addition to driving the clocks and the time-to-zero indicators on the control console.

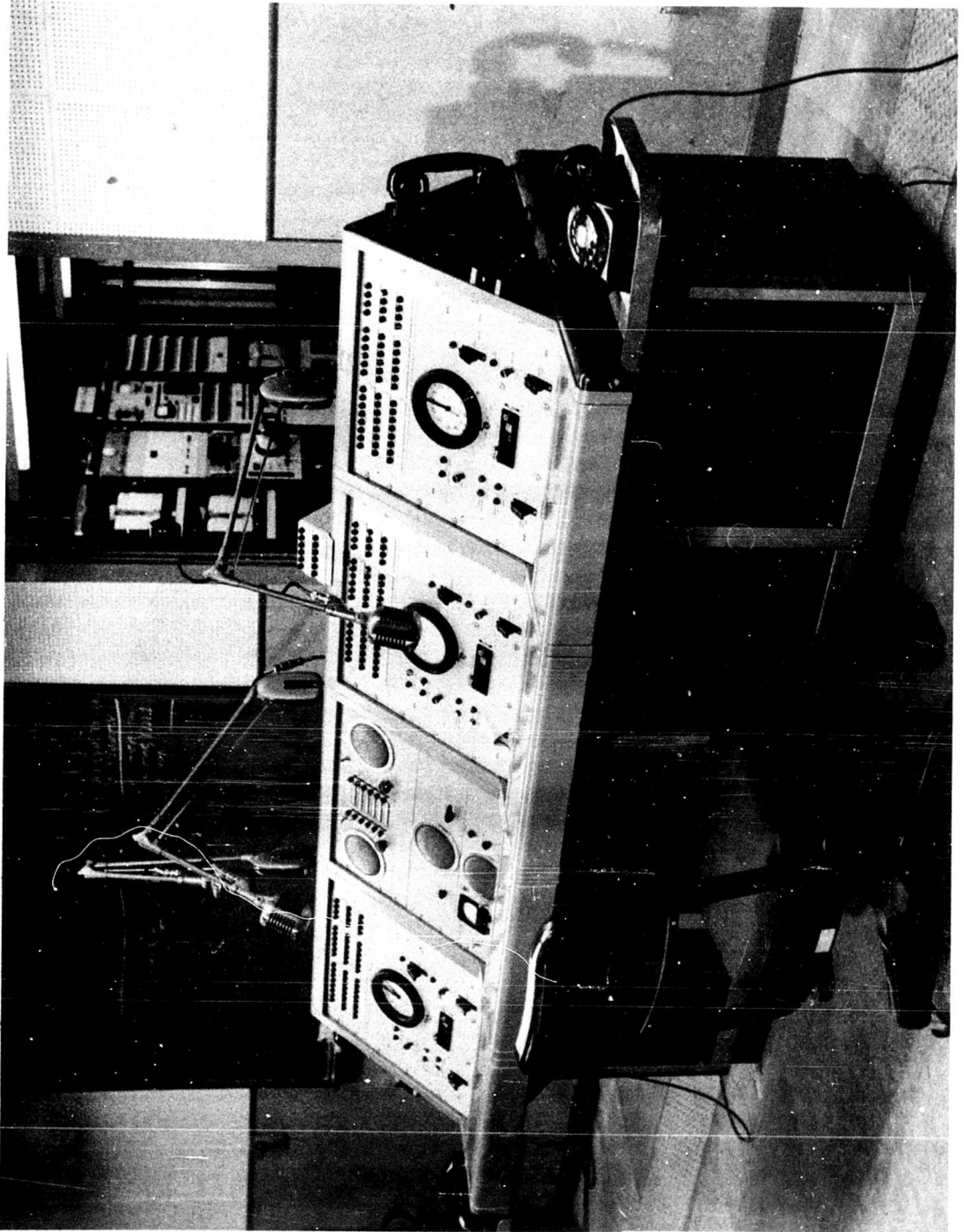

Fig. 4.1 - Eniwetok control console

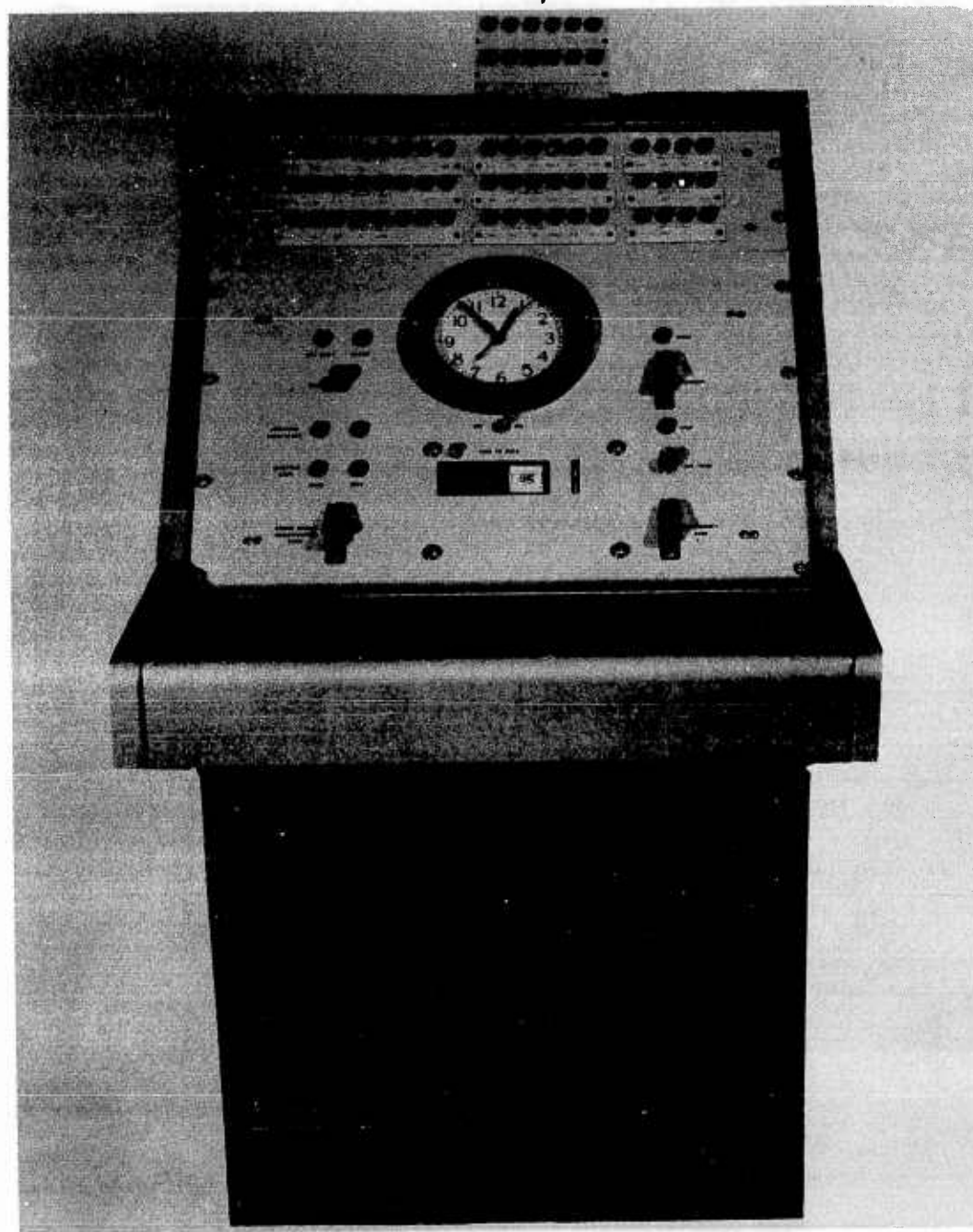

Fig. 4.2 - Typical control panel

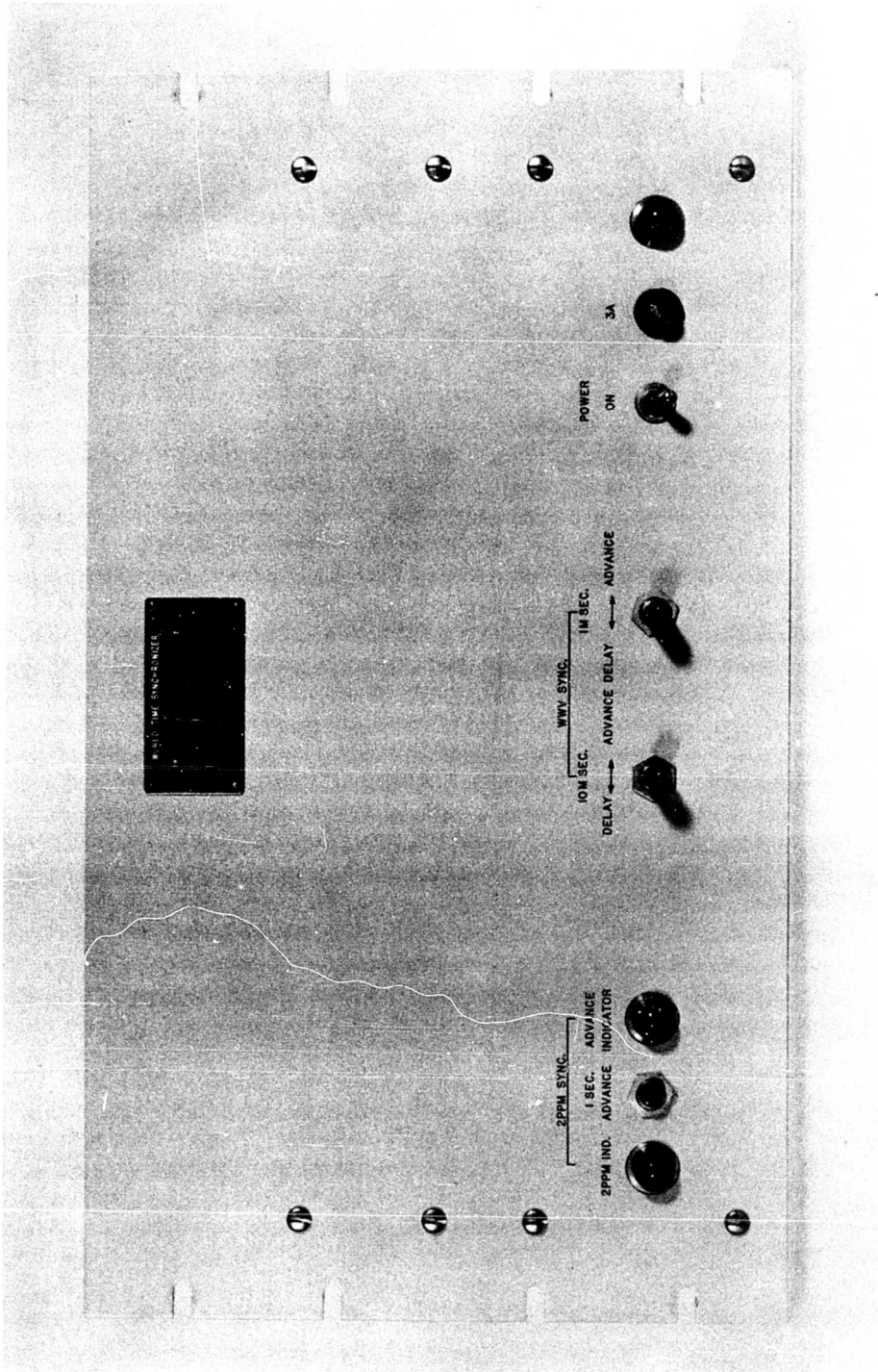

Fig. 4.3 - World-Time Synchronizer, Type SN-1

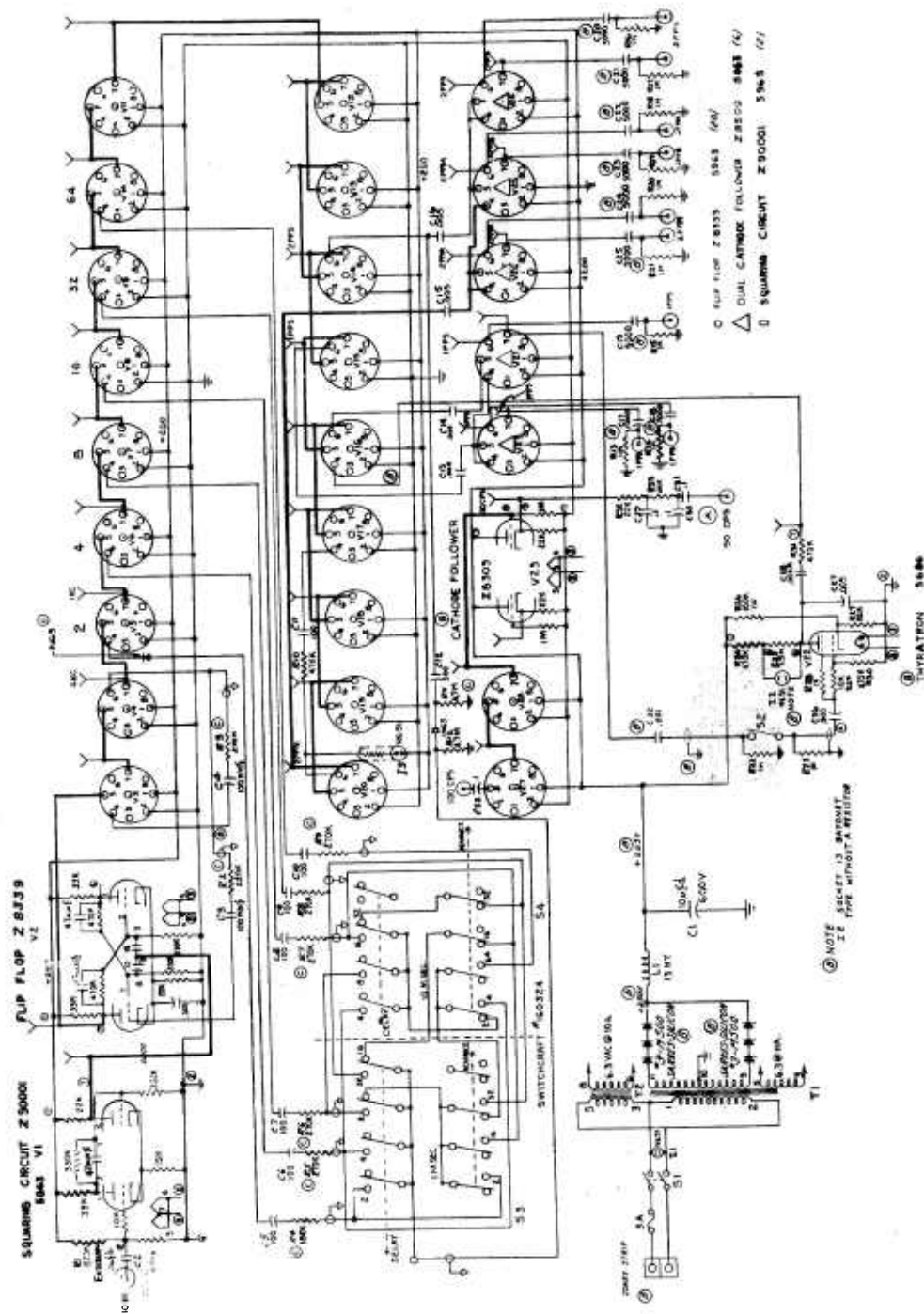

Fig. 4.4 - Schematic diagram of world time synchronizer

#### 4.2.1 System Synchronization

The 1-pps output of the synchronizer triggered a Waterman Rakscope which displayed the audio-time signal from WWVH, Honolulu, or JJY, Japan. The 440- and 600-cycle tones broadcast once each second by WWVH are interrupted for about 20 msec; in approximately the center of this break, a time tick of six cycles of a 1000-cycle tone appears on the precise second. Controls on the front panel of the synchronizer advanced or delayed the trigger pulses in 1- or 10-msec increments until the beginning of the sweep coincided with the first cycle of the six-cycle tick. These adjustments were made every day and after each shot to correct for possible oscillator drift. In this way, accuracy was assured, even if the CP should be without a time check for long intervals.

The 2-ppm and 2-pps outputs of the synchronizer were used to drive the stepping switch in the sequence timer. In order to synchronize the 2-ppm output (indicated by a flashing light) to the minute and half-minute audio signals, the operator determined the interval and operated a switch which advanced the output signal the required number of seconds in 1-sec increments.

#### 4.2.2 Construction

The synchronizer was designed to require a minimum of maintenance. Almost all tube circuits were in the form of standard plug-ins except for the thyatron circuit designed and manufactured by EG&G. To facilitate isolation of malfunctions, jacks were provided at appropriate points in the binary system.

#### 4.3 STEPPING-SWITCH SEQUENCE TIMER, TYPE SA-4

All timing signals originated from the new stepping-switch sequence timers designed by EG&G for Operation Hardtack. The new timer, shown in Fig. 4.5, was a single rack-mounted unit for transmitting timing signals in the form of encoded pulses to decoding equipment in the distribution stations. The new timers were incorporated into all of the timing and firing systems except the Boxer system.

Prior to Hardtack, the sequence of timing signals had been determined by a cam-shaft with removable cams. On the Plumbbob timer the number of signals was limited to fourteen. Since each signal required a separate pair of lines to the signal distribution station, the number of signals was also limited by cable capacity. The complex experimenter requirements for Hardtack necessitated a greater number of signals and greater flexibility in changing or adding signals.

The basic mechanism of the new timer was developed from the airdrop timer used on John shot of Operation Plumbbob. In conjunction with the signal decoder, the new timer made it possible to send all signals from the timer to the distribution station over a single pair of wires, thus reducing the time and effort required for installation.

A schematic diagram of the stepping-switch sequence timer is shown in Fig. 4.6. From the outputs of the divider-synchronizer, the base-time selector circuit selects the desired stepping rate. From -60 min. to -2 min. the timer operates at a stepping rate of 2 ppm. At -2 min. the timer automatically changes to the 2-pps rate. These pulses, originating from the divider-synchronizer unit, are fed to the contacts of the base-time selector relay, which, when de-energized, passes the 2-ppm signal to a monostable multivibrator. The multivibrator generates a pulse 80 volts in amplitude and 130 milliseconds in duration for each base-time pulse. These pulses actuate the main keying relay, which advances two 25-contact stepping switches (Automatic Electric Type 45) through 625 positions, each position corresponding to a definite point in

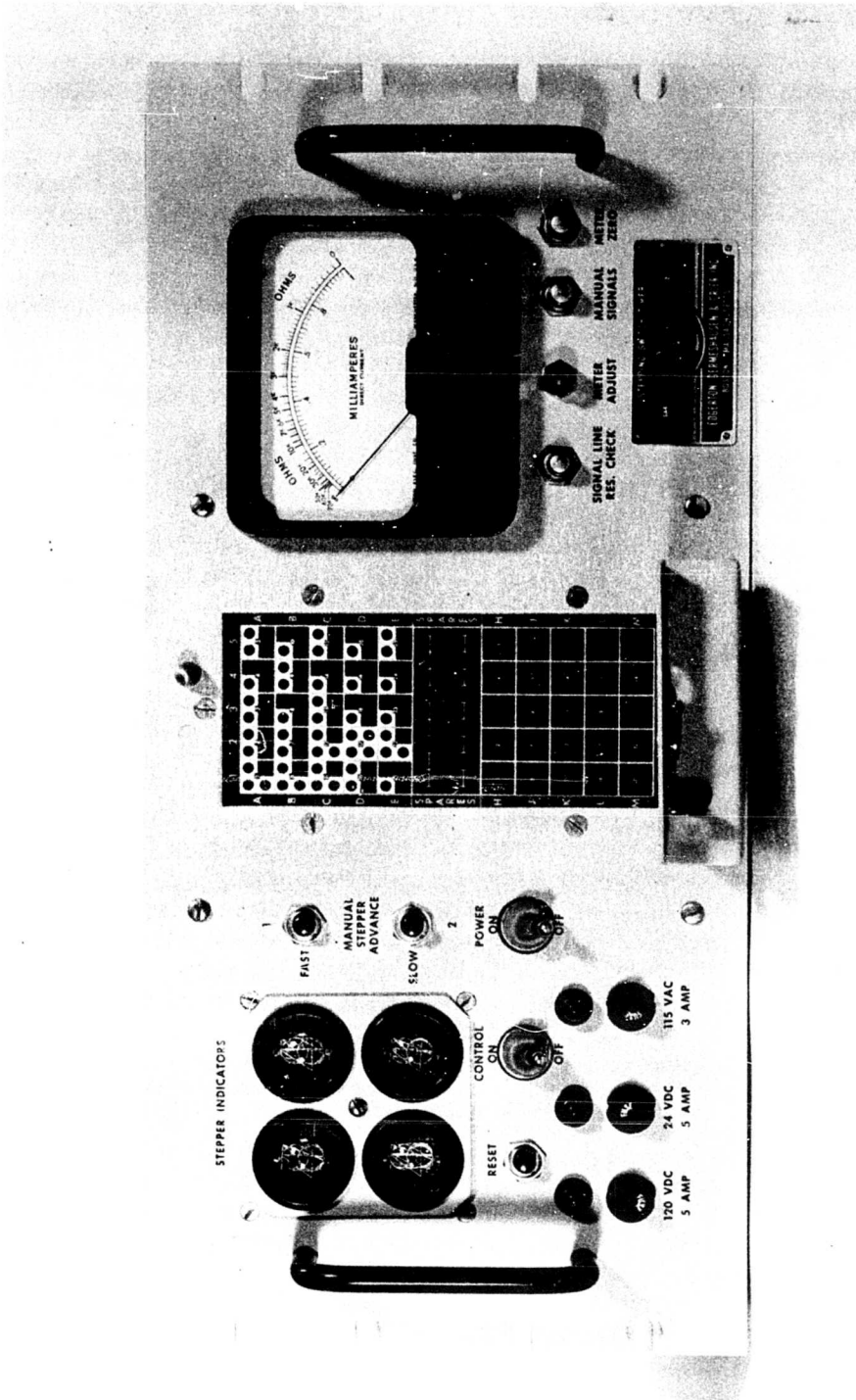

Fig. 4.5 - Stepping-Switch Sequence Timer, Type SA-4

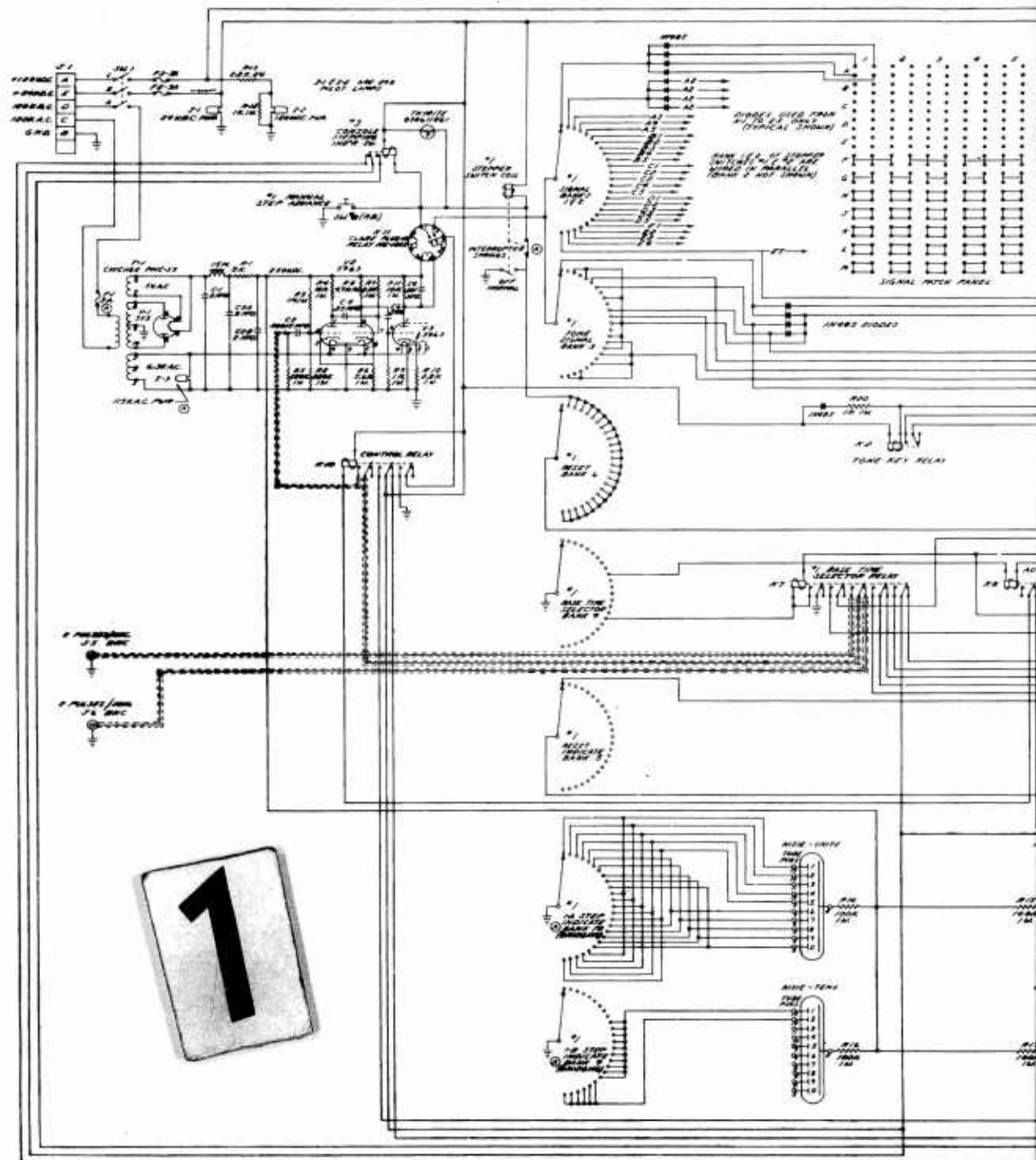

Fig. 4.6 - Schematic diagram of



time. The stepping switches are so arranged that the second of them will advance one position for each complete cycle of the first. Four Nixie tubes on the front panel numerically indicate the exact position of each stepping switch. The stepping rate is indicated on the control console by alternately flashing lights.

For Hardtack, as many as 22 separate timing signals were available. These signals could be selected at any half-minute interval from -60 to -2 min. and at any half-second interval from -2 min. to +1 sec by programming a patch board on the front panel of the timer.

The patchcords serve as the connection between the two stepping switches and allow the signal to pass from the contacts on the stepping switch to the master signal relay, a four-pole double-throw Automatic Electric BQA relay with a diode resistance-damping circuit. The damping circuit prevents back voltage from breaking down the contacts of the keying relay and destroying the signal-selection diodes. A secondary function of the circuit is to permit adjustment of the signal length.

Each time the master signal relay is energized, it transmits a signal 120 volts in amplitude and approximately 100 msec in duration to the substation decoders.

At the end of the automatic-timing sequence (+1 sec), the base time selector relay is reset to the 2-ppm rate, and the stepping switches return to starting point. A reset signal is sent to the decoders when the reset switch is actuated.

A pre-programmed circuit, independent of the patchboard system, provides eighteen relay closures for the voice-time tone signals at -60 min., -30 min., -15 min., and at every 60-second interval thereafter until zero time.

The resistance of the signal lines to the decoder can be checked with the ohmmeter on the front panel. Signals may also be sent out manually to advance the substation decoders to a desired position.

#### 4.4 SIGNAL DECODER

The timing signals that operate the user relays are distributed from the signal decoder. This unit converts the timing pulses from the sequence timer to steady signals. Two types were employed in the timing and firing installations, the CP Signal Decoder, Type SA-5A, and the Substation Signal Decoder, Type SA-5.

Figure 4.7 is a photograph of the signal decoder. As each timing signal is received from the timer, the corresponding indicator lamp at the top of the front panel is lit. A patchboard permits selection of any of the signals from the sequence timer and distribution of these signals to user relays. Provision is made for sending signals manually and for checking the resistance of signal lines on the ohmmeter. A local reset button and a selector switch and indicator for remote or local power complete the panel controls. Signals are distributed from connectors on the rear of the unit.

A schematic diagram of the Signal Decoder, Type SA-5A, is shown in Fig. 4.8. The signal repeater relay is actuated by the 100-msec pulses originating from the sequence timer. Operation of this relay energizes the function relay patched to the decoder stepping switch through the signal patch panel. Twenty-four of these function relays can be patched to the contacts on the decoder stepping switch; each point on the stepping switch corresponds to a particular point in time, the time being determined by the pulses programmed out of the sequence timer.

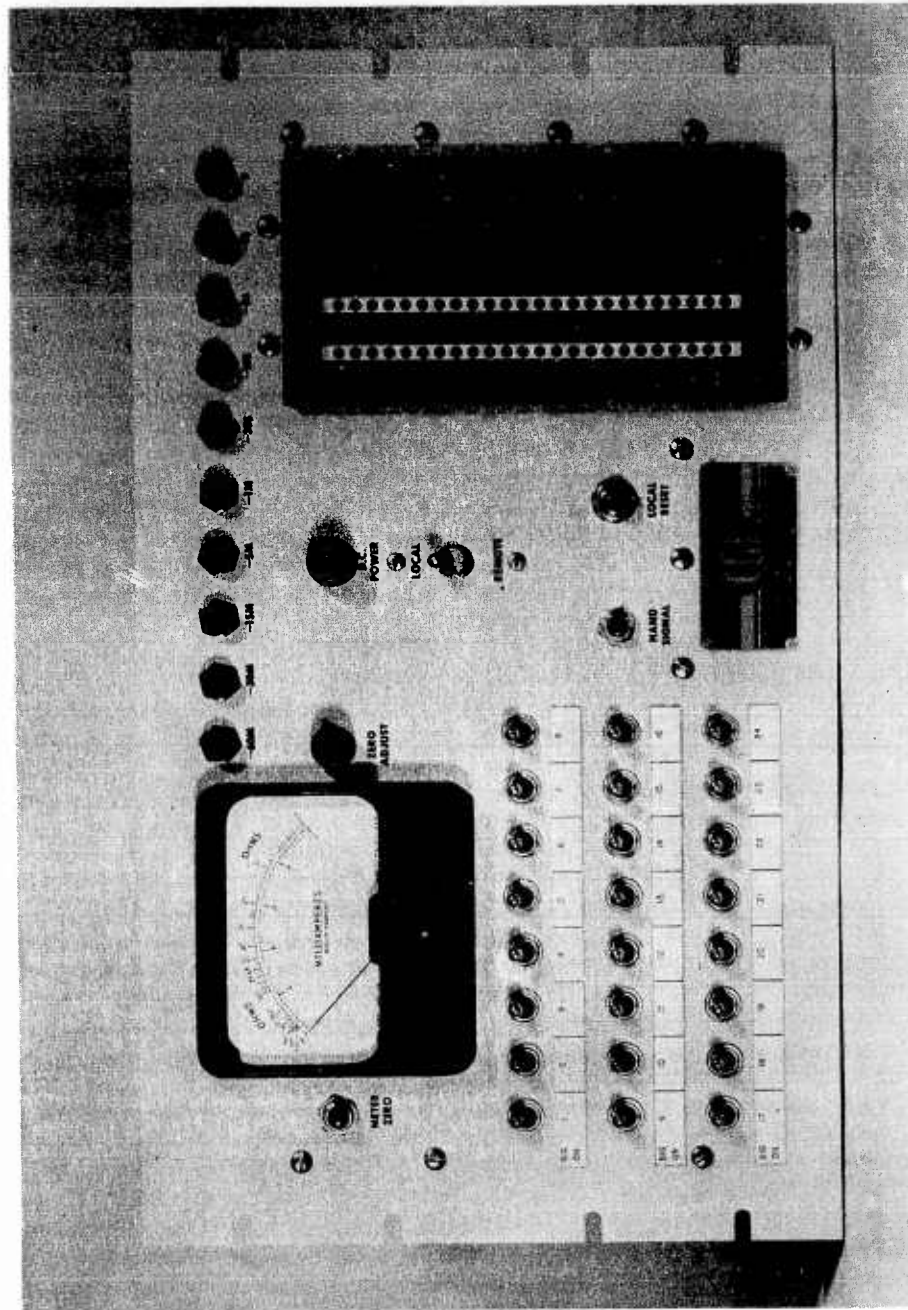

Fig. 4.7 - Signal Decoder, Type SA-5





When the signal repeater relay is energized, one pole energizes the stepping switch motor. At the end of the 100-millisecond pulse, the relay is de-energized, allowing the stepping switch to advance to the next position in readiness for the next signal pulse. The other pole of the relay grounds the coil of the function relay which then seals itself through its own contacts and routes a steady 72-v d-c signal through the signal distribution control units to the individual user relays. The function relay remains closed until cutoff time at +1 sec.

Power to the substation decoders could be applied locally or remotely from the Control Point during a dry or live run. The decoders could be reset at the station itself or from the Control Point. When the decoder is reset, a relay closure keys a tone transmitter; this signal is monitored at the Control Point.

A stepping-switch monitor, located on the rear panel, is operated by a relay closure on alternate points of the stepping switch. The closure is transmitted to the Control Point as a monitor tone which lights an indicator light. Each decoder has an indicator on the control console; synchronization of these indicators shows that the system decoders are "in step".

The SA-5 Decoder is identical to the SA-5A Decoder except that the fire line and the relays for keying tone transmitters and for lighting control-console indicators have been omitted. In the SA-5A Decoder, the arm and fire signals originate from two of the function relays.

#### 4.5 SIGNAL DISTRIBUTION

The 12-meter signal distribution panels used on previous operations were adapted to the new timing system and installed in the timing stations. In addition, new panels (Signal Distribution Control Units, Type SA-2) were constructed for the Control Point racks. Each of these units, as shown in Fig. 4.9, contained twelve 1-in. meters manufactured by International Instruments; the space gained by the use of miniaturized meters permitted grouping of several panels in a limited area.

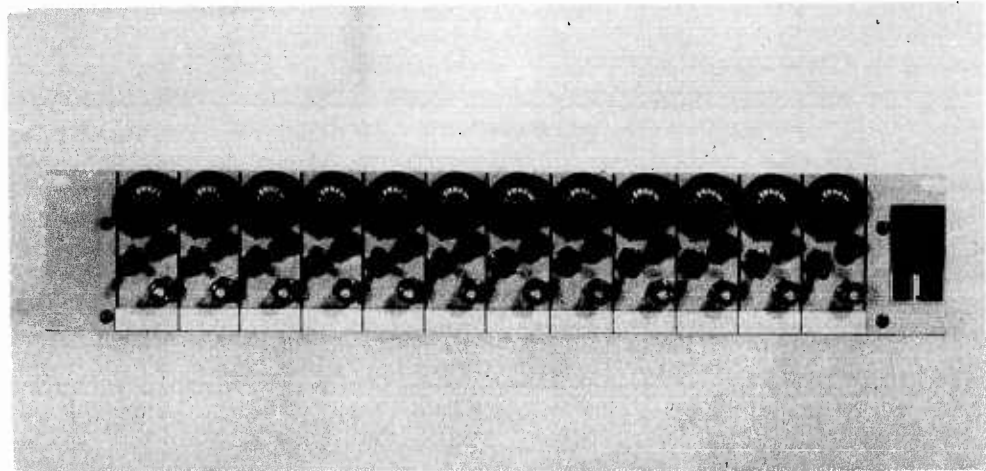

Fig. 4.9 - Signal Distribution Control Unit, Type SA-2

The meters indicated the current passing through the individual user signal lines. Below each meter were a potentiometer for adjusting line current, a monitor light, and an on-off switch. Signal time, user, and station number were marked on identification strips below each meter.

Signals from the decoder function relays were distributed to the individual metered circuits through the decoder patchboard, thus making it easy to change a user from one signal to another. Signals could be distributed to as many as 72 individual users from the patchboard. If necessary, other users could be accommodated by paralleling signals on additional meter panels.

#### 4.6 ZERO RACKS

Thirty-two EG&G zero racks fired the surface, barge, and underwater events of Operation Hardtack. Three types were designed according to LASL, UCRL, and DOD requirements. Type SA-8 racks detonated the 15 LASL shots, and type SA-9 racks detonated the 15 UCRL shots. The two DOD underwater shots required special radio-operated racks in splash-proof containers.

Each zero rack was thoroughly tested before installation at the zero site. After it was installed, dry runs were conducted to insure operational compatibility with other zero-site equipment. Operation of the rack was controlled automatically by timing signals from the CP.

Each of the zero racks for the LASL and UCRL shots had an aluminum chassis which was panel-mounted in a console frame, as shown in Fig. 4.10. Environmental conditions at the proving grounds dictated the incorporation of a dehumidifying unit, housed in the lower section of the console.

The functions of these racks included (1) supplying high-voltage to the device, (2) arming the zippers and the X-unit, (3) interlocking the various circuits to obtain the proper sequence of operation, (4) applying power to the "fire" solenoid, and (5) providing monitoring indications of these functions at the Control Point.

The electrical wiring of zero racks SA-8 and SA-9 differs in some respects, but both units have the same basic components. Each unit contains seven function relays, a high-voltage power supply, three magnetic-amplifier type relay controllers, and three monitor relays. Complete circuit descriptions and operating procedures are contained in a separate report.<sup>1</sup> The front panel of the rack is shown in Fig. 4.11, and schematic diagrams are given in Figs. 4.12 and 4.13.

The radio-operated zero rack is shown installed in Fig. 4.14. Three signals broadcast from the CP on the radio-tone networks operated the unit. The -60 sec signal readied the zero rack, the -30 sec signal armed the device, and the fire signal applied power to the "fire" solenoid. Normally, a zero rack supplies the high-voltage, but specifications for this special rack required only a relay closure at the appropriate time.

A schematic diagram of the radio-operated zero rack is given in Fig. 4.15. Eight channels of on-off zero-rack function information were monitored remotely at the CP by the radio telemetering system. Three of these channels monitored the possible leakage of salt water into the bomb casing.

1. "General Instructions: Zero Racks, Type SA-8 and SA-9"  
Report No. E-1728, EG&G, Inc., March 1958.

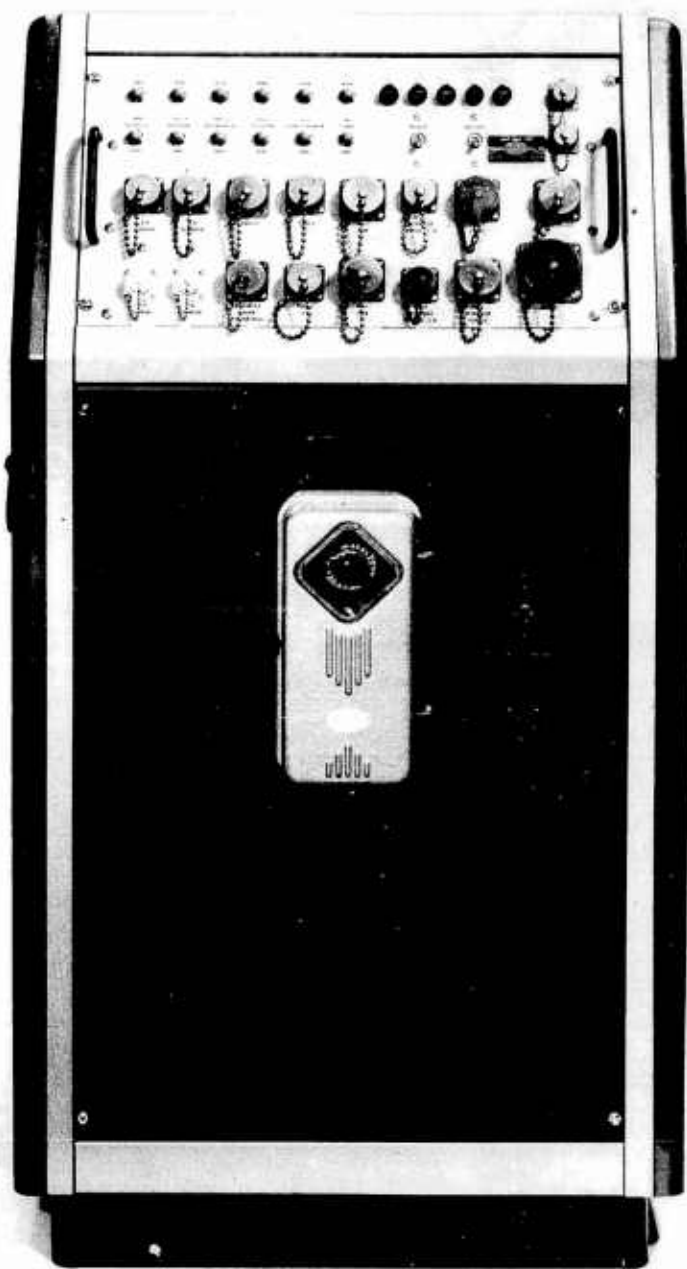

Fig. 4.10 - Zero rack

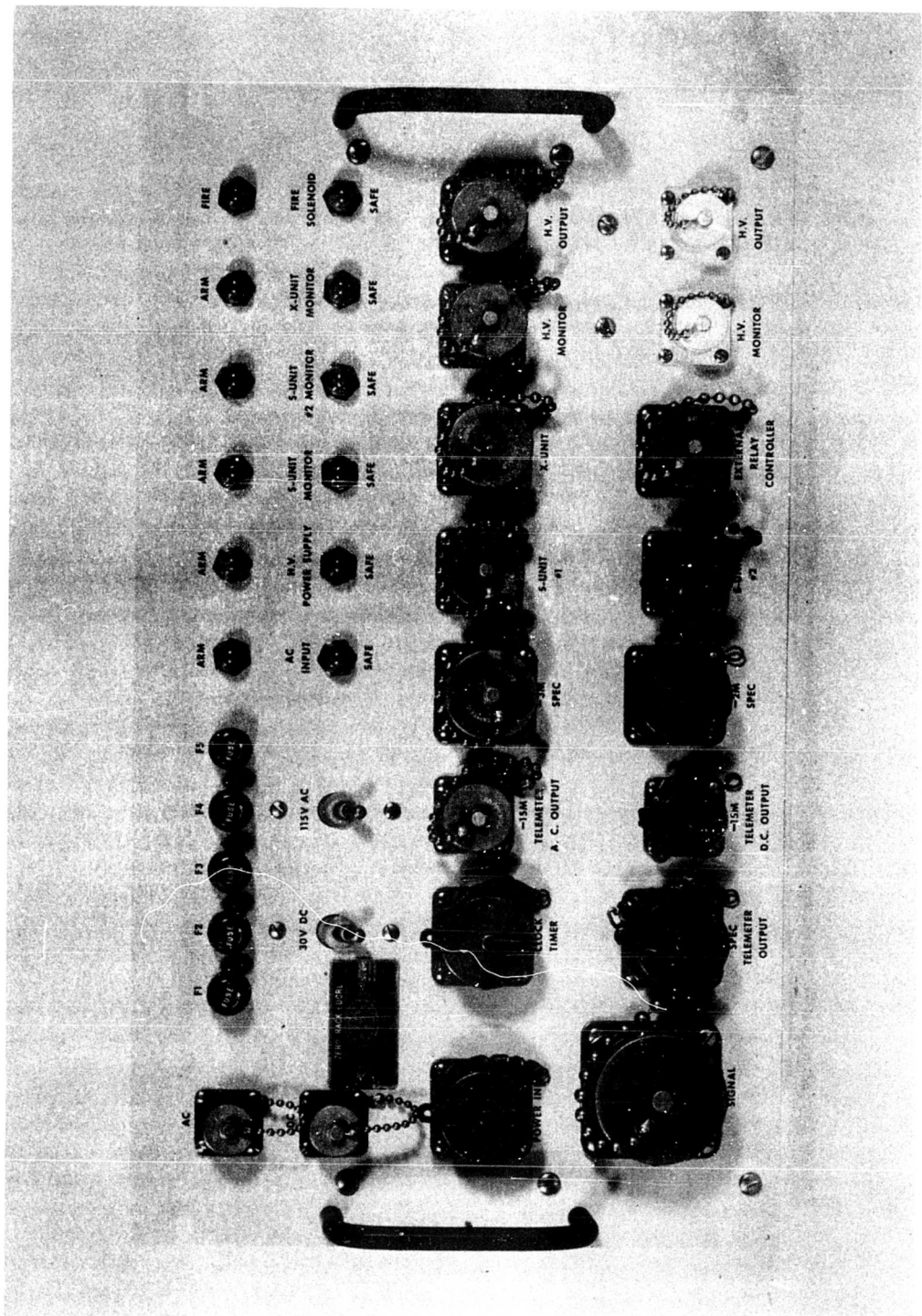

Fig. 4.11 - Zero rack panel

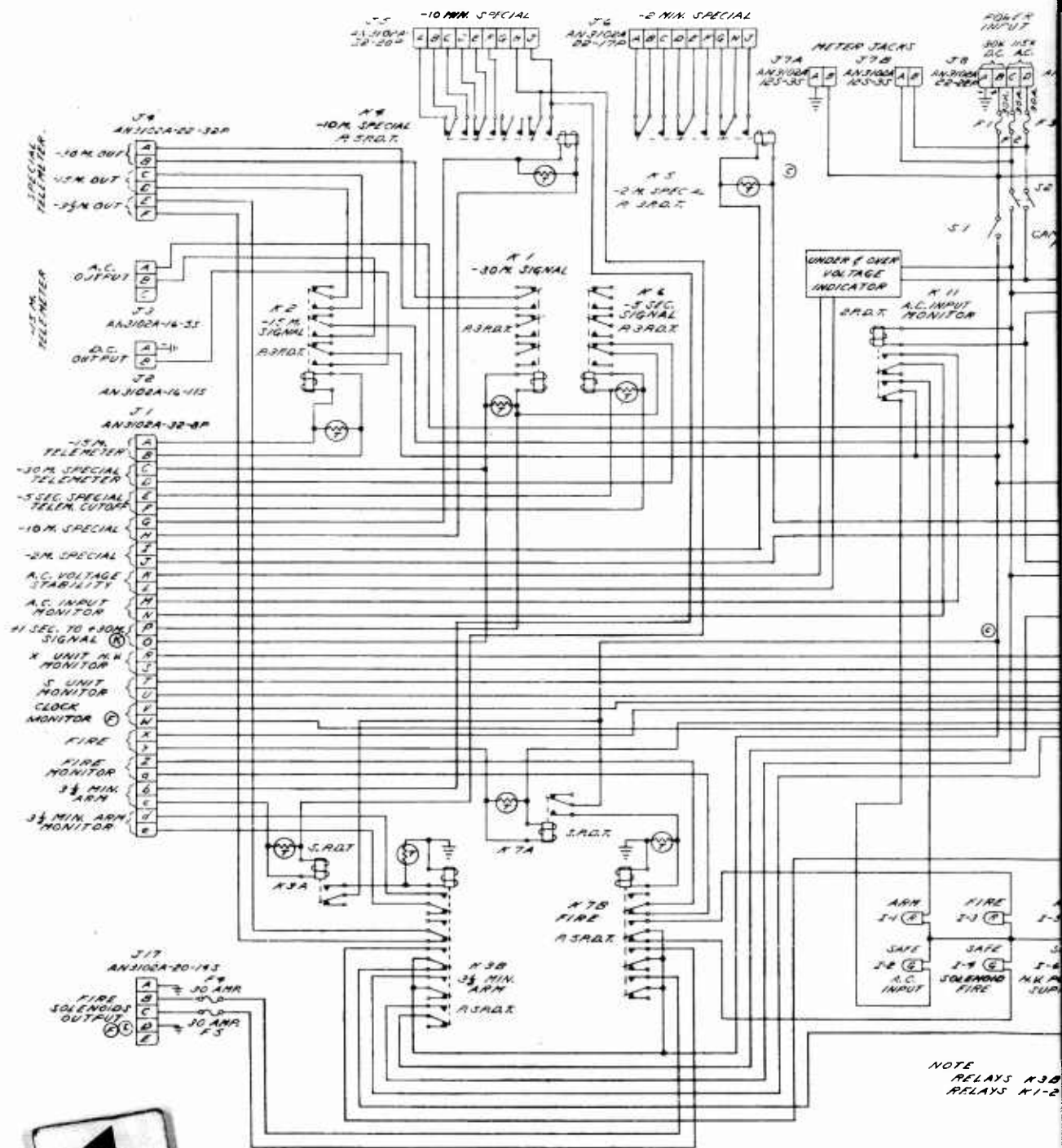

Fig. 4.12 - Schematic diagram of Ze



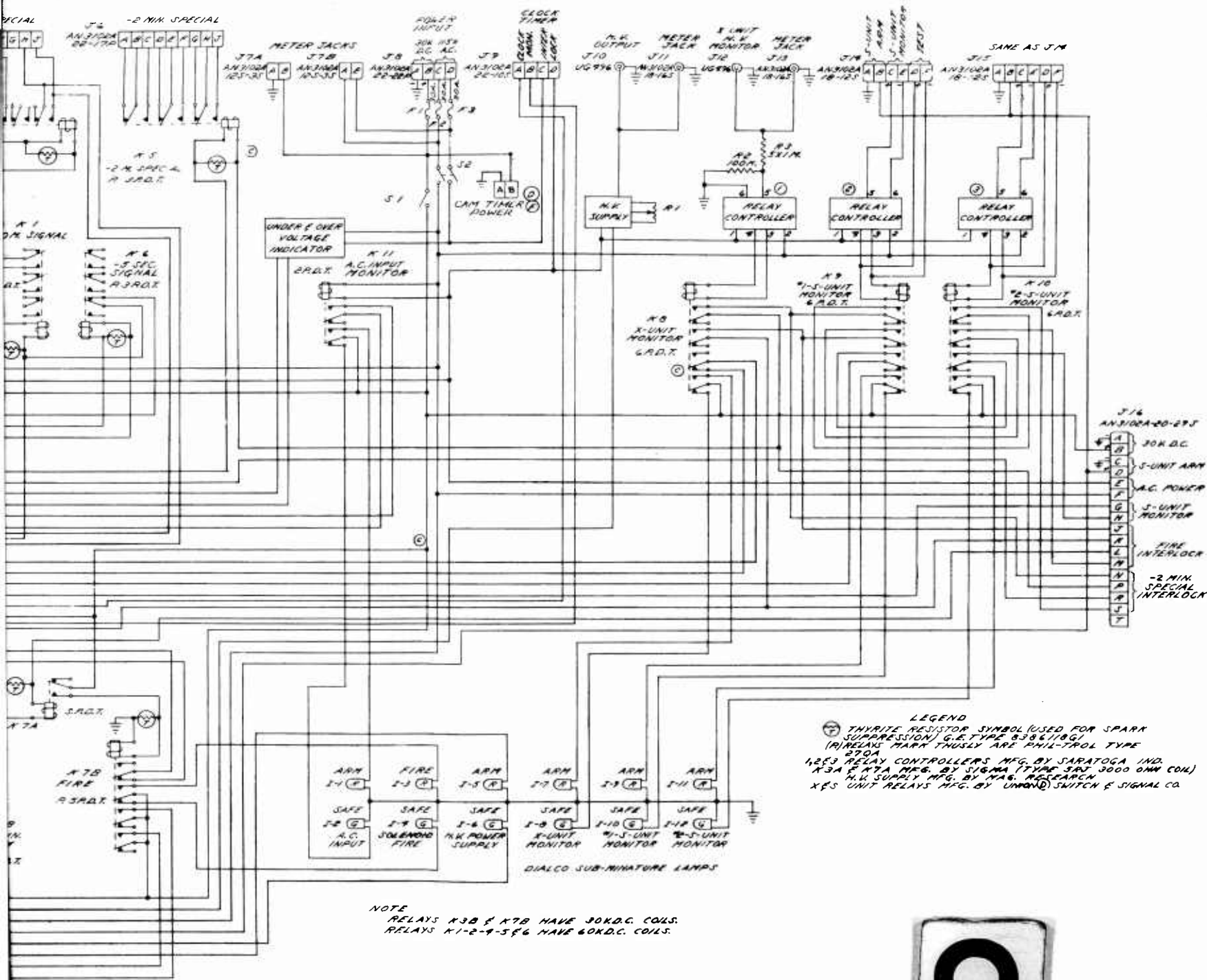

Fig. 4. 12 - Schematic diagram of Zero Rack, Type SA-8





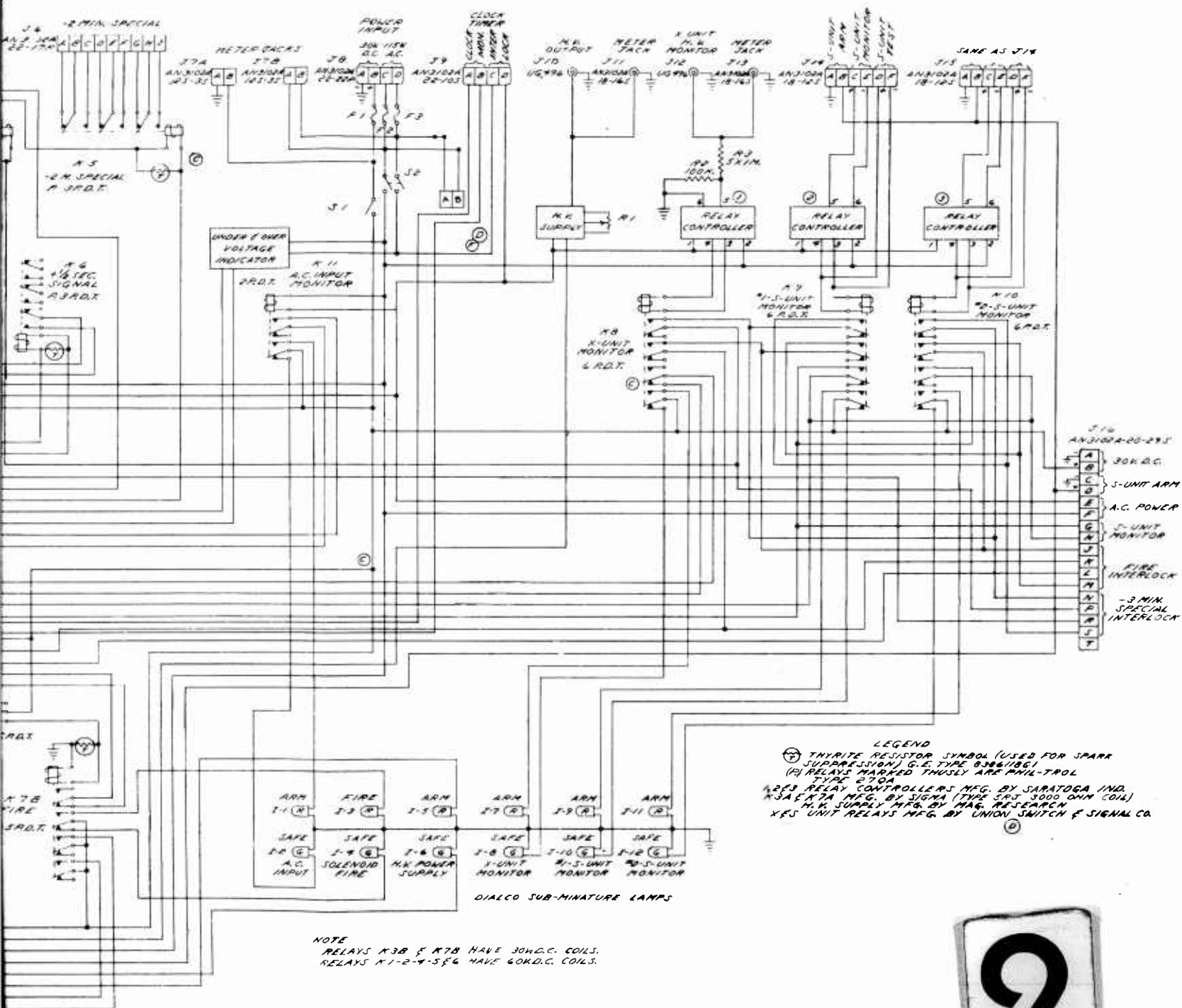

Fig. 4. 13 - Schematic diagram of Zero Rack, Type SA-9



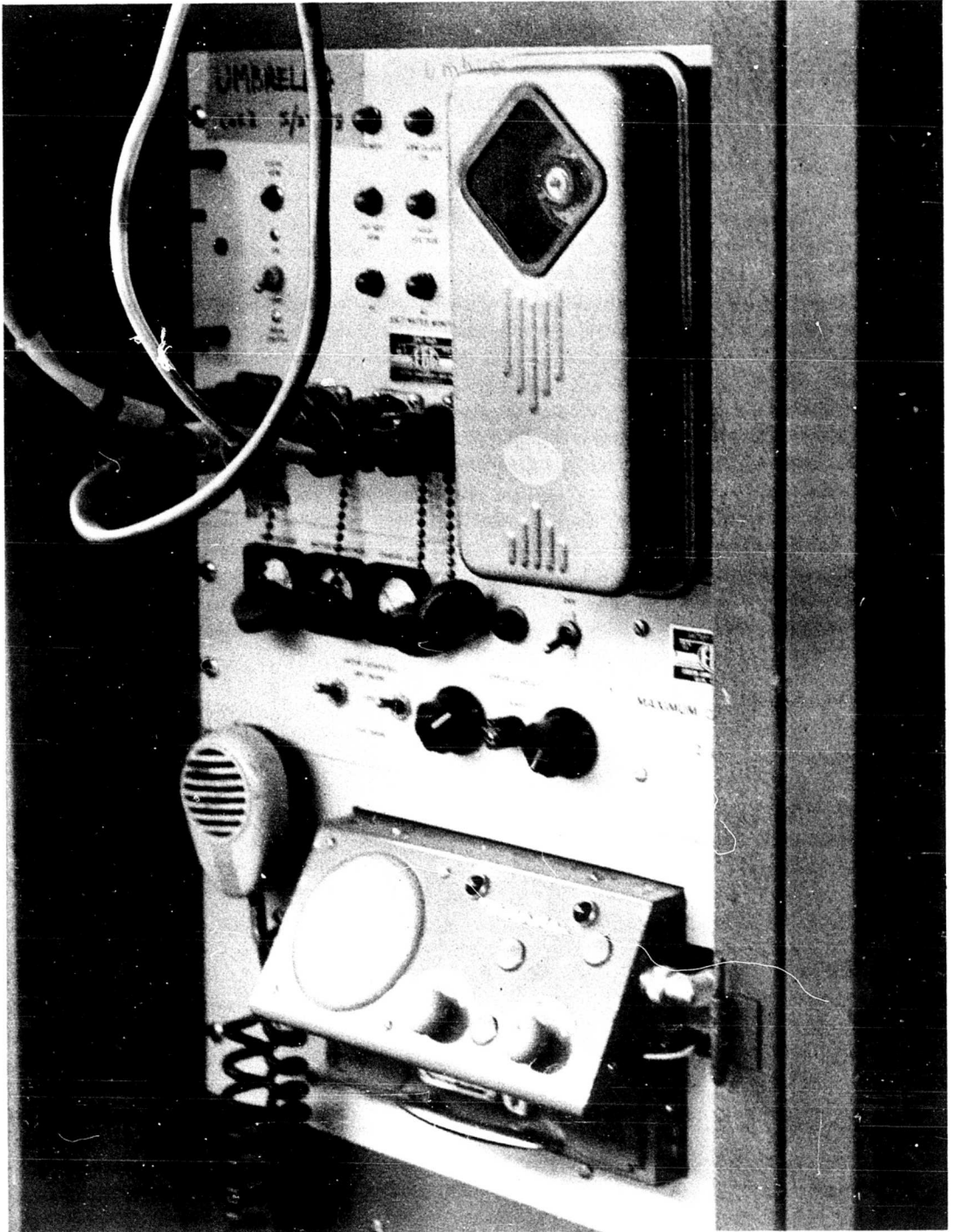

Fig. 4.14 - Umbrella zero rack

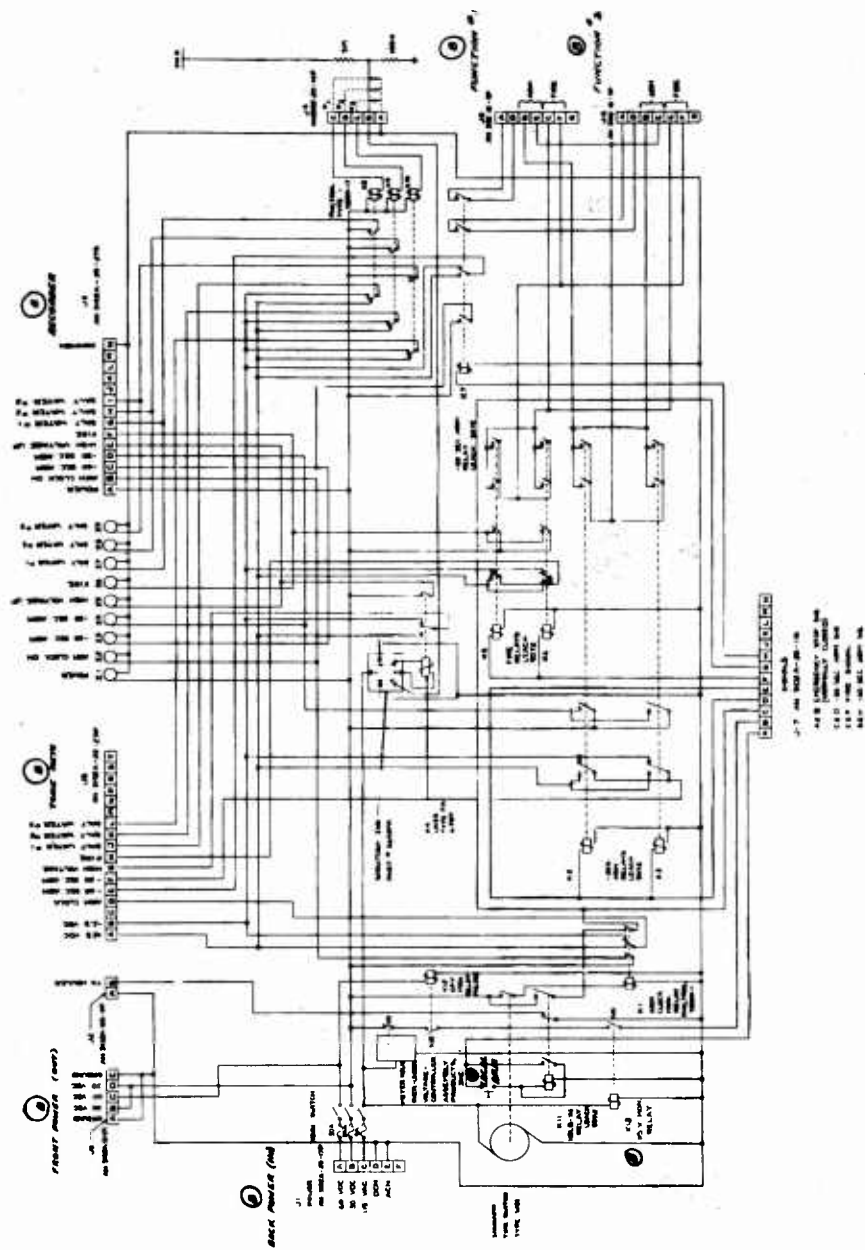

Fig. 4.15 - Radio-operated zero rack

#### 4.7 ZERO FIDUCIAL FLASH

EG&G was requested by TU-3 Program 9 to provide a zero-time reference to certain of the Wahoo and Umbrella experimenters. The radio fiducial system was adequate for the shipboard photographic installations, but it was possible that the aircraft might be flying in a null at zero time and would not be able to receive the signal; as a back-up, therefore, EG&G provided a flash bulb array which would generate a bright flash at zero time visible from the aircraft and other photostations.

The array consisted of a 3-ft square plywood platform on which were mounted fifty-two flashbulbs. The platform was installed on the after deck of the LCM zero barge, as shown in Fig. 4.16; it was protected by a clear plastic shield which permitted visibility from all sides as well as from above.

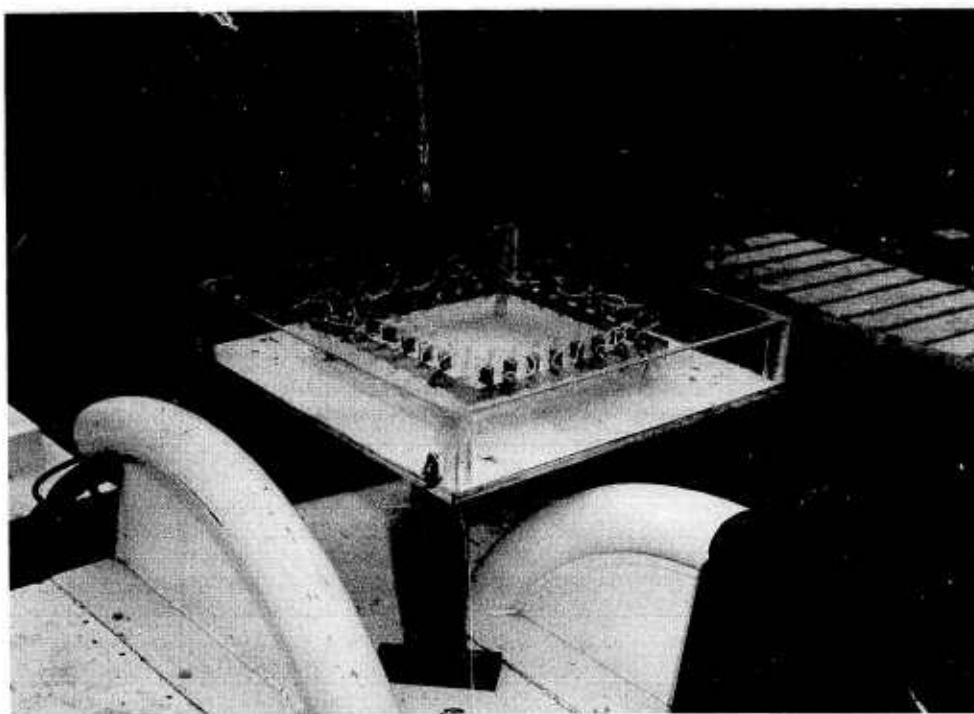

Fig. 4.16 - Flashbulb array

## Chapter 5

### RADIO TONE SYSTEMS

#### 5.1 RADIO-TONE TIMING AND FIRING SIGNALS

The EG&G radio-tone signal system was considerably extended for Hardtack. Five independent radio timing signal systems were set up; one on board the Boxer, two at the Eniwetok CP, and two at the Bikini CP. One of the systems at Bikini was removed early in the operation to Johnston Island. These systems provided ten basic timing signals by which experimenters could synchronize their equipment with the EG&G timing system.

Two firing-tone systems linked to the Glenn timing system transmitted arm, fire, and emergency-stop signals to the zero barges for the underwater shots. When the zero signal was transmitted from the sequence timer, these two systems operated in conjunction with the radio-tone timing signal system to fire the device; a combination of any two of the three signals transmitted was required for this purpose.

The radio signal systems had three distinct functions: (1) to operate major experimenter instrumentation on the balloon shots and on the underwater events, (2) to fire the underwater devices, (3) to supplement the hardwire systems, providing relay closures for experimenters in locations where it would have been impossible or impractical to run signal lines.

Radio timing signals were used extensively at Eniwetok Atoll. The Bikini hardwire system, however, was adequate for all user requirements, and radio signals were not transmitted, although the capability existed.

##### 5.1.1 Basic System

A block diagram of the basic radio-tone signal system is shown in Fig. 5.1. The timing signals are furnished by the regular hardwire timing system. The tone-signal transmitting system consists of a tone generator and an f-m transmitter.

##### 5.1.2 Sequence of Operation

A relay closure is received from the timing system decoder at the time when a radio signal is to be sent. Closure of this relay produces a one-half second pulse which operates a tone generator.

Each time signal from the decoder selects two different audio frequencies from the tone generator: an "on" tone which is common to all signals, and the particular frequency for the signal being transmitted. The combined tones modulate the carrier frequency of an f-m transmitter which broadcasts the signal to the radio relay units at each user location. All signals for a particular system are transmitted on the same carrier frequency. As each radio tone is transmitted, the monitoring receiver at the Control Point causes the appropriate indicator lamp on the control console to light.

The duration of these tones is approximately one-half second in order to eliminate accidental triggering of user equipment by spurious signals. Both the common tone and the particular tone for the time signal must be received in order to effect a relay closure. Delays inherent in the radio system cause the radio signals to lag the wired signals approximately 0.25 sec.

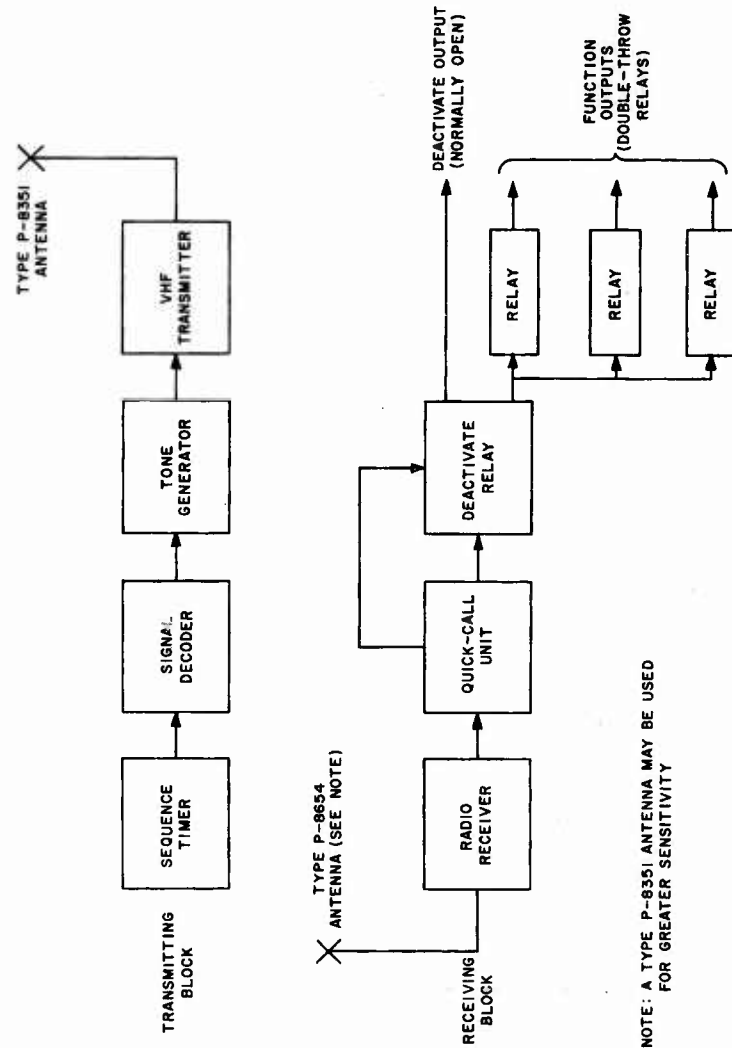

Fig. 5.1 - Block diagram, radio-tone signal system

### 5.1.3 Radio Relay

A new EG&G transistorized radio relay unit replaced the radio-tone barrels used on Plumbbob. The new relay unit was considerably smaller (10-1/2 in. x 8 in. x 14 in.) and weighed just 20 lb. The dry battery pack incorporated into the unit provided approximately ten days' service. The battery pack contained four 67-1/2-v batteries, two 6-v batteries and two 1-1/2-v batteries. The previous unit had a separate battery case, and provided only about nine hours' service before recharging was necessary.

Signal outputs and the antenna connection are taken from sealed connectors mounted on top of the water-tight case. Figure 5.2 shows the top of the unit and Fig. 5.3 is a schematic diagram. The radio receiver is a Motorola, Type NU-135 d-c VHF receiver; it is mounted with an auxiliary unit manufactured by EG&G. The two units together select the incoming tone signals and convert them into relay functions in the following manner: Audio frequency tones transmitted from the CP are impressed across six resonant-reed relays. If these tones are in the proper frequency, they cause two of the reeds to vibrate. The reed contacts make and break connection at the audio frequency rate and transfer voltage across the coils of the magnetic relays through an integrating network. The contacts of these relays are then connected to the three-pin socket on top of the unit, providing a signal to the user.

Functions could be turned on or off by radio signals. Each radio relay unit was capable of providing three "on" signals at any of the available times and one "off" signal at +1 sec. The "off" tone relay, when energized by a combination of the "off" tone and the common tone, impressed 6 volts across the "off" coils of the four function relays. Users requiring more than three signals could use two or more units.

Prior to a dry run, the Control Point transmitted a "deactivate" signal to all radio relay users. As long as the switch on the top of the unit was in "Shot Signal Runs Only" position, the radio relay would not operate, except on shot runs when no "deactivate" signal was transmitted. If the user, however, desired to operate his equipment on a dry run, he could override the "deactivate" signal by throwing the switch to "All Signal Runs" position.

If the antenna mounted on the unit proved to be unsatisfactory in a particular location, the antenna could be mounted separately and connected to the unit by RG/8U cable.

### 5.2 RADIO FIDUCIAL SYSTEM

For most above-ground nuclear detonations, a photosensitive unit triggered by the appearance of light from the burst can provide an accurate zero reference signal; however, a special problem was presented by the underwater events on Operation Hardtack: a zero-reference signal could not be obtained by the usual methods since no light would be visible from the detonation, nor would there be any cables from the zero area to the CP or the experimenter locations. To provide experimenters with an accurate zero signal, therefore, a specially designed system, operated by radio tone, was employed on Shots Wahoo and Umbrella.

The transmitting unit was mounted on the zero barge from which the device was suspended. Receivers were located on several shipboard stations for general experimenter usage, in the RB-50 aircraft for photographic equipment, and in the CP for triggering the world time system.

Schematic diagrams of the transmitting and receiving units are shown in Figs. 5.4 and 5.5. The transmitting unit included a trigger circuit, a voltage-controlled oscillator, and a Motorola f-m transmitter. The receiver consisted of a modified Motorola receiver strip, an audio amplifier, a high-pass filter, a pulse-forming circuit, and an output trigger circuit. Four

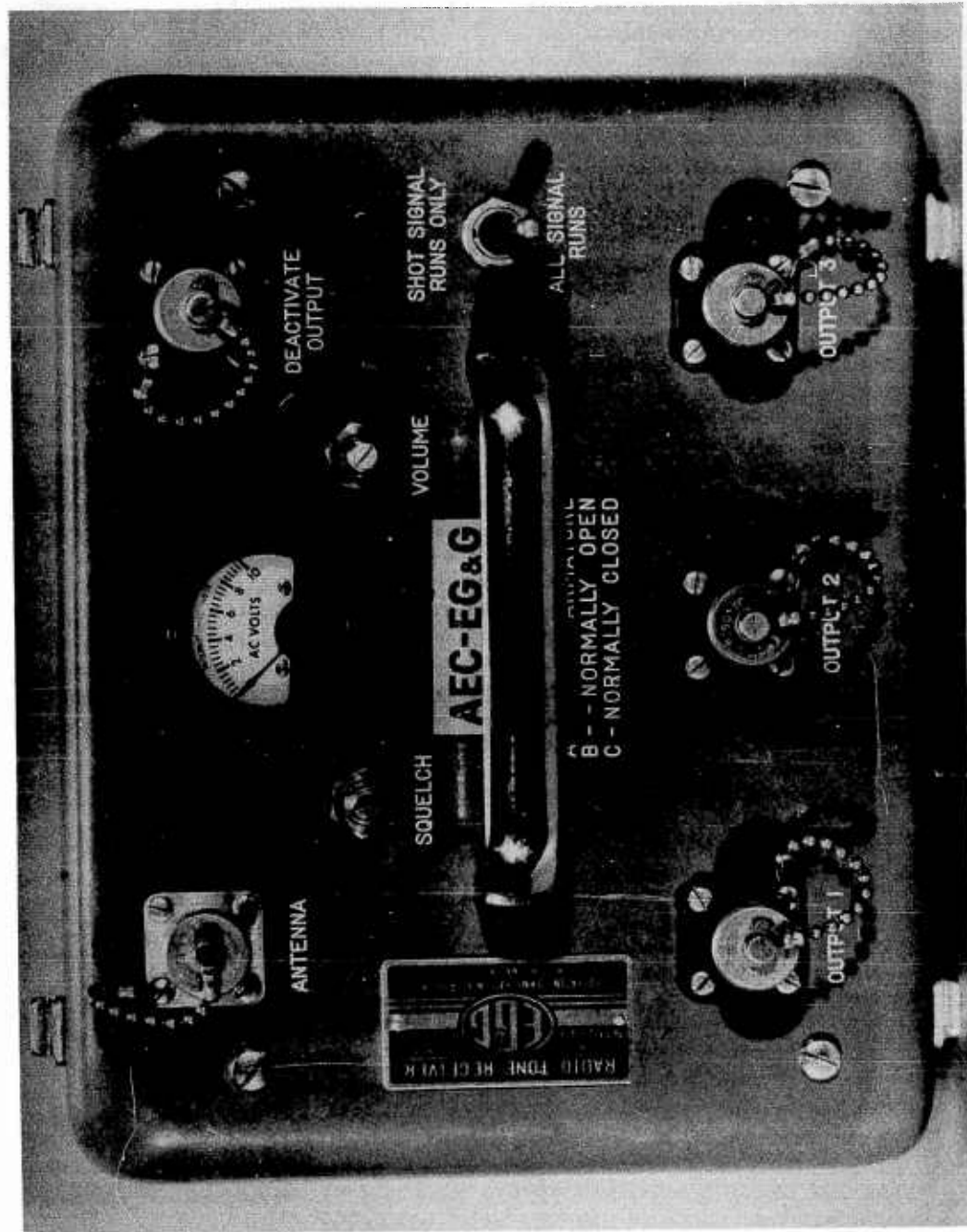

Fig. 5. 2 - Radio relay unit





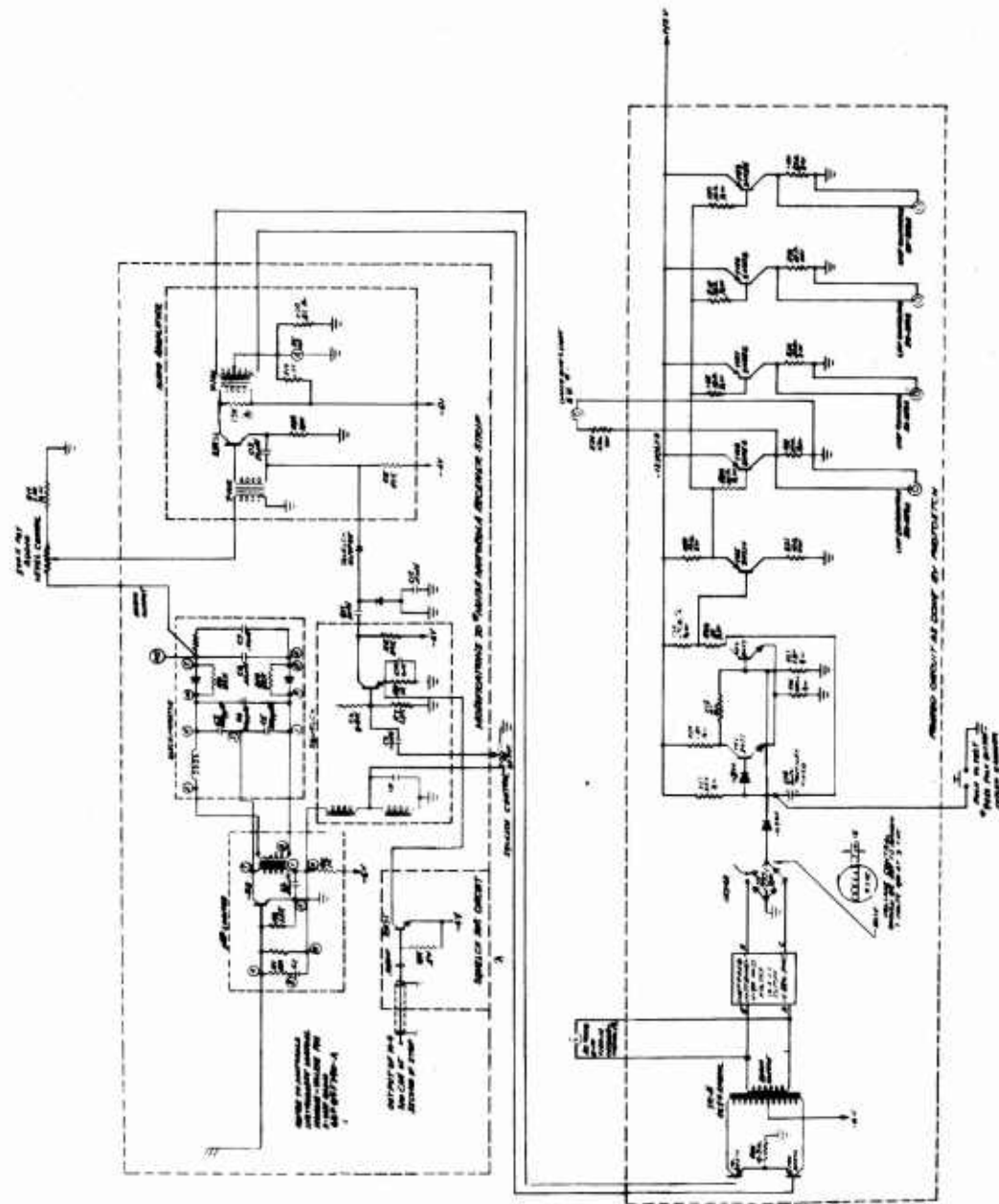

Fig. 5.5 - Schematic diagram of radio fidu receiver

isolated output circuits supplied the zero signal to experimenter relays. D-c power was supplied by a battery pack included in the unit.

Prior to zero time, the oscillator maintained a frequency of 9.7 kc, which was transmitted continuously to the receiver units. At zero time, a pulse from the load ring of the weapon caused the output frequency of the oscillator to change to 10.5 kc. The receiver, monitoring the frequency shift, sent an output pulse to experimenter relays. The output pulse had a nominal rise time of 50  $\mu$ sec and an average amplitude of 10 volts, depending on the condition of the batteries. With the leading edge of the pulse used as the reference point, the total delay time of the system was 0.3 msec  $\pm$  0.1 msec.

The effective range of the zero fiducial system was only about seven miles, and reception difficulty was experienced at the CP. On Wahoo D-1, the CP fidu receiver was replaced by a more sensitive unit in an attempt to get a stronger signal. The zero signal was transmitted on the shot run. A full account of fidu system operation could not be obtained since several experiments did not operate; however, all other fidu receivers operated properly.

Prior to Shot Umbrella, modifications were made on the receivers to help prevent erratic triggering, and the transmitter was protected from voltage surges. The system operated properly on Umbrella; of nineteen receivers, only one false-triggered before zero time.

### 5.3 RADIO TELEMETRY

For the underwater shots, a radio telemetering system was designed to monitor zero rack functions. A commutator unit on the zero barge transmitted coded monitor signals to the decommutator units at the CP. The system required only three radio tones to monitor nine functions. A block diagram of the system is given in Fig. 5.6.

The commutator unit includes a regulated power supply, a 24-position stepping switch, three voltage-controlled oscillators and three relays. A 14-conductor cable leads to the telemeter monitor connector on the zero rack chassis. All the normally open contacts of the monitor relays are wired to one common output, and all the normally closed contacts to another. The common outputs are applied to the relay coil for a "yes" signal when the function is operating properly and to another relay coil for a "no" signal. The three oscillators provide the method of coding: a 5.4-kc oscillator for the "yes" signal, a 3.9-kc oscillator for the "no" signal, and a 7.35-kc oscillator for synchronization. The 7.35-kc frequency returns the stepping switch of the decommutator unit to home position at the end of each cycle, thus assuring synchronization of both stepping switches.

During each cycle, the stepping switch samples the voltage at each monitor relay in the zero rack, and the proper frequency for each position is transmitted on an r-f carrier frequency to the decommutator unit.

The CP decommutator unit, shown schematically in Fig. 5.7, contains a modified Motorola receiver with three output amplifiers. A discriminator unit permits the desired frequencies to pass to the amplifiers. The decommutator stepping switch, driven synchronously with the commutator switch, activates a relay for each of the monitored functions in turn. Nine magnetically latching function relays are provided; the appearance of either a "yes" or a "no" signal will cause the relay either to maintain its original position or to change position, depending on the signal previously received for the particular function. Operation of the function relays routes 24 v-dc to indicator lights on the control console.

On the two underwater shots, the telemetering system was set up to monitor the following zero rack functions:

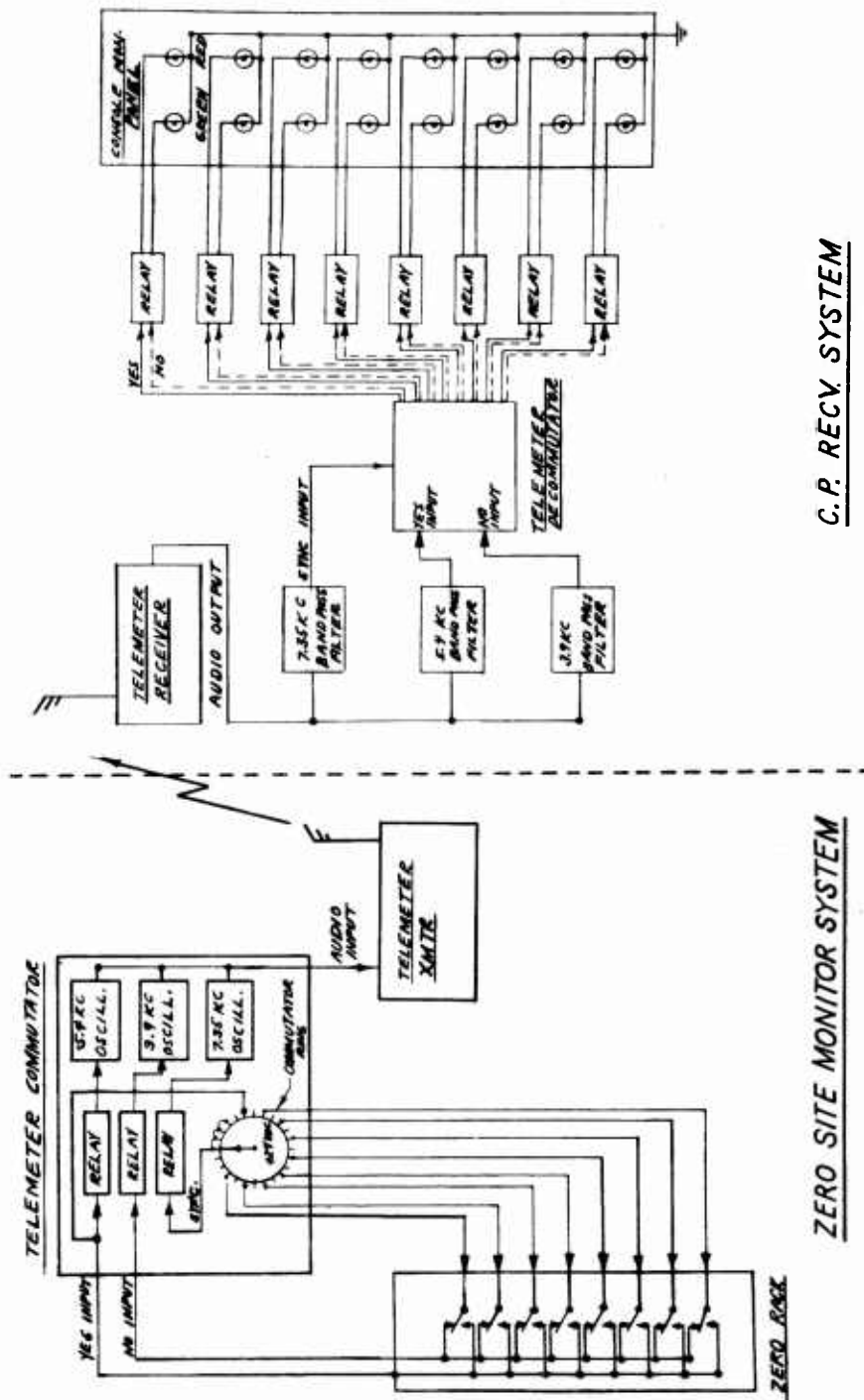

C.P. RECV SYSTEM

ZERO SITE MONITOR SYSTEM

Fig. 5. 6 - Block diagram, radio telemetering system



Arm Clock  
-60 sec Arm  
-30 sec Arm  
High-Voltage  
Fire Relay

Fire Monitor  
Salt Water No. 1  
Salt Water No. 2  
Salt Water No. 3

Rough sea conditions damaged the antenna installation on the Wahoo zero barge. Last-minute replacement of antennas resulted in too much interference, and telemetering had to be abandoned. On Shot Umbrella, a tone drift on the 7.35-kc synchronization tone caused erratic monitoring. The telemetering receiver unit was manually synchronized, and monitoring was accomplished.

#### 5.4 HOWLER MONITORING

An additional radio monitoring system comprising a transmitter on the zero barge and a "howler" receiver at the CP was employed on the underwater shots. As originally set up, the system was to monitor a-c and d-c instrument power on the zero barge; however, before the Wahoo and Umbrella shots, it was deemed more essential to monitor closure and opening of the arm clock switch. This monitoring system was intended to provide a warning in case of misfire. The transmitter was keyed until the arm clock switch closed prior to zero time. Had a misfire occurred, the transmitter would have been keyed again when the arm clock switch opened and an audible warning signal sounded by the CP "howler" receiver.

## Chapter 6

### OPERATION NEWSREEL TIMING AND FIRING

#### 6.1 INTRODUCTION

Launching of the two DOD high-altitude missile shots, Teak and Orange, was originally scheduled to take place on Bikini Atoll but was later moved to Johnston Island. Because of the unexpected change of firing location, it was necessary to transfer a portion of the timing and firing system from the Bikini installation to Station J-70, Johnston Island. A redesign of the equipment to provide for its independent operation was accomplished in the field by making use of spare parts of the Eniwetok and Bikini timing systems. The equipment was operationally checked out at Eniwetok Atoll and shipped to Johnston Island. Teak and Orange were fired on 31 July and 11 August 1958, respectively.

#### 6.2 TIMING AND FIRING COMMITMENTS

The main objective of the EG&G timing and firing group (TU-5) on Newsreel was to supply experimenters with an accurate sequence of timing signals related to burst time. These signals enabled recipients to start and stop their equipment at the proper times. Other objectives were to (1) determine the time of burst of the two shots with respect to WWVH and (2) provide experimenters' stations with a system of radio links over which voice-time announcements, synchronized to the timing system, could be transmitted.

#### 6.3 COMPONENTS OF TIMING AND FIRING SYSTEM

The control room (Station J-70) containing the timing and firing equipment was located in the ABMA firing bunker (Station 5-6002). The system included a power rack, world time rack, timer rack, distribution rack, and console. Figure 6.1 is a view of the control room with the control console in the foreground and the timing and communications racks in the rear.

Communication transmitters were keyed and modulated from the CP, but transmitters were remotely located in order to minimize r-f interference with missile telemetering equipment. The two AOC nets, the local voice-count transmitters, and the radio-tone transmitters were located on the western end of the island, where a 100-ft antenna mast was erected. The single-side-band transmitters for long-range voice countdowns were on Sand Island, south of Johnston.

Rack components are listed below:

##### Rack No. 1: Power Rack

Esterline-Angus recording voltmeter for monitoring 115 v-ac and 120 v-dc  
Esterline-Angus recording voltmeter for monitoring 24 v-dc  
General Radio Power Supply and Multivibrators, Model 1102-A  
General Radio Piezo-Electric Crystal Oscillator, Model 1101-A  
EG&G Battery Charger, Type PS-3  
Ac-dc switch panel

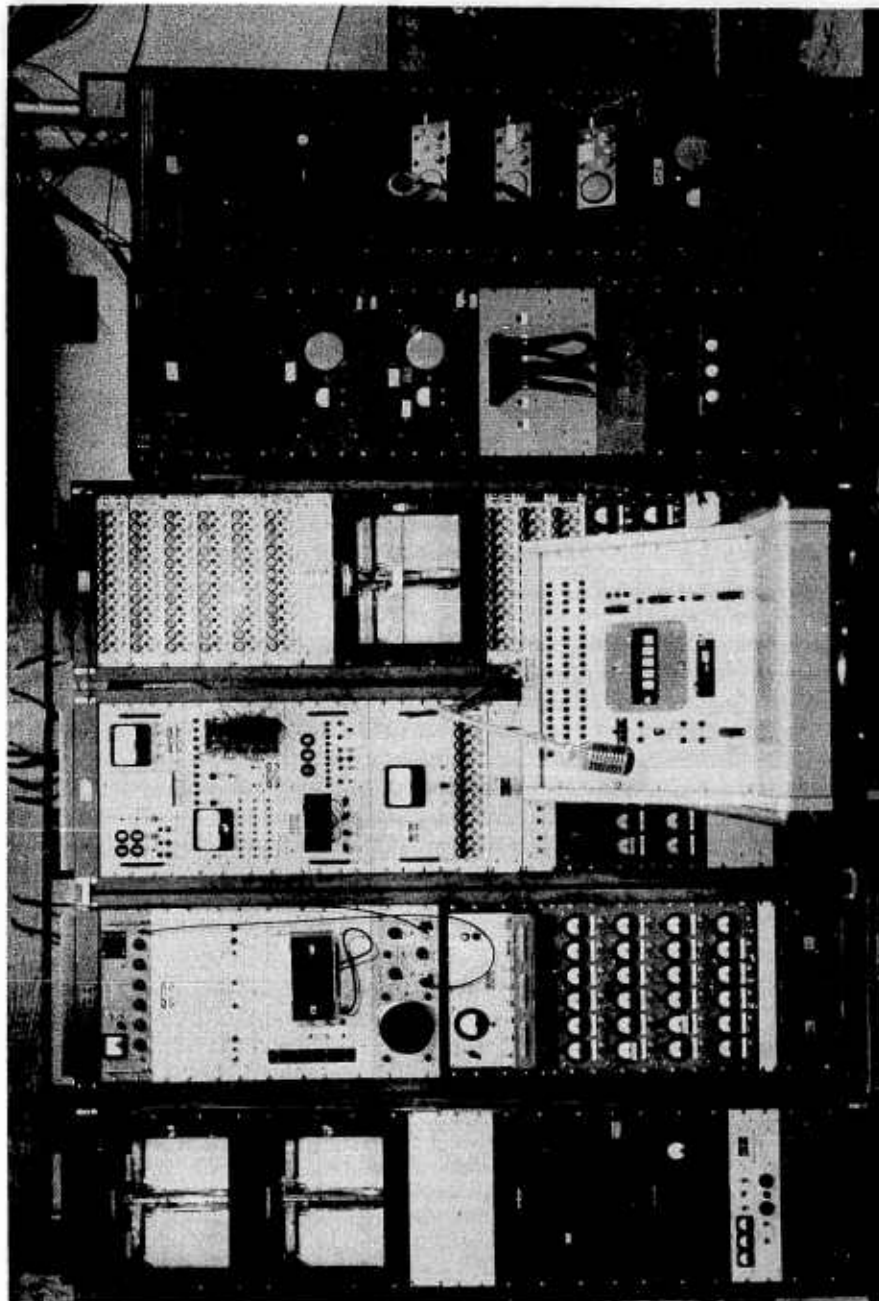

Fig. 6.1 - Control room, Johnston Island

Rack No. 2: World Time Rack

WWV Receiver, Beckman-Berkeley, Model 905  
EG&G World Time Synchronizer, Type SN-1  
EG&G World Time Clock, Type TD-3  
Hewlett-Packard Oscilloscope, Model 120A  
Brush Power Supply, Model BL-809  
Two 12-meter signal distribution panels  
Ac-dc switch panel

Rack No. 3: Timer Racks

EG&G Stepping Switch Sequence Timer, Type SA-4  
EG&G CP Signal Decoder, Type SA-5A  
EG&G Airdrop Timer, Type SA-10  
Airdrop Timer Power Supply  
Signal Distribution Control Unit, Type SA-2  
Relay Panel, Type RE-2  
Decoder Ready Indicator, Type RE-3  
12-meter signal distribution panel  
Emergency-Stop Relay Panel, Type RE-4  
Ac-dc switch panel

Rack No. 4: Distribution Rack

Six Signal Distribution Control Units, Type SA-2  
Esterline-Angus 40-pen graphic recorder  
Three Signal Distribution Control Units, Type SA-2  
12-meter signal distribution panel  
Ac-dc switch panel

Rack No. 5: Radio Rack

Tone generator  
Radio-Time consolette  
Voice-Time No. 1 consolette  
Audio patch panel  
Keying  
Audio line amplifier  
Ac-dc switch panel

Rack No. 6: Radio Rack

243-Mc emergency-band monitor receiver  
EGG-net transceiver  
12-tone monitor-light receiver  
Voice-Time No. 1 receiver  
Voice-Time No. 2 consolette  
Ac-dc switch panel

## 6.4 OPERATION OF TIMING AND FIRING EQUIPMENT

### 6.4.1 Timing Signals

Timing signals were generated and transmitted by both radio tone and telephone line from the CP from -1 hour. Standard radio signals were broadcast at a frequency of 157.45 Mc to operate the photographic equipment in the two RB-36 aircraft photostations. Four timing signals, initiated by the Stepping Switch Sequence Timer, Type SA-4, occurred prior to lift-off at -60 min., -30 min., -15 min., and -5 min. Flexibility of the timing system was maintained by means of the "hold" signal incorporated into the sequence timer. This signal held the experimenters at any point in the sequence until the launch signal was received from ABMA.

Predicted time of flight was programmed in the Airdrop Timer, Type SA-10. At missile lift-off, the signal given by ABMA initiated operation of the airdrop timer, which, in turn, activated the master signal relay and the Signal Decoder, Type SA-5, and furnished the remaining timing signals. The airdrop timer was programmed to run to +15 sec, with signal relays dropping out at +12 sec. The airdrop timer was similar in design to the Plumbbob unit used in the Boxer installation for Yucca shot. The range of the timer was extended from 100 seconds to 220 seconds, and the circuitry was adapted to the new timing system so that all timing signals were carried to the signal decoder on a single line.

Both a-c and d-c Blue Boxes were used on each event to provide experimenters with a zero signal of millisecond accuracy.

The following timing-signal sequence was provided for Teak and Orange. Ten of these signals were transmitted by radio tone and hardwire simultaneously. The rest were hardwire signals only.

<u>TEAK</u>	<u>ORANGE</u>
-60 min.	-60 min.
-30 min.*	-30 min.*
-15 min.*	-15 min.*
-5 min.*	-5 min.*
-170.3 sec (lift off)*	-153.8 sec (lift off)*
-165.0 sec	-145.0 sec
-151.4 sec	-110.0 sec
-137.2 sec	-98.0 sec
-131.6 sec	-97.5 sec
-76.2 sec	-66.6 sec
-70.0 sec	-60.0 sec*
-66.6 sec	-43.0 sec
-60.0 sec*	-40.6 sec
-57.8 sec	-15.0 sec*
-51.4 sec	-5.0 sec*
-46.8 sec	-2.5 sec
-40.0 sec	-1.5 sec
-15.0 sec*	-1.0 sec*
-5.0 sec*	0 test*
-2.5 sec	+12 sec cutoff*
-1.0 sec*	
0 test*	
+12 sec cutoff*	

\*Radio-tone signals transmitted simultaneously with hardwire signals.

A total of 153 hardwire timing signals were delivered on each of the two events, and ten radio-tone signals were transmitted to the RB-36 aircraft; an additional "deactivate" radio-tone signal was employed on dry runs only. Required relays at user stations were installed by EG&G personnel to accommodate all of the hardwire timing signals.

#### 6.4.2 "Destruct" Signal

An additional electrical connection was provided between the EG&G timing system and the ABMA system to prevent experimenters from receiving further timing signals upon transmission of the "destruct" signal to the missile. This signal was initiated in the event that trouble developed in the missile after lift-off.

#### 6.4.3 Determination of Time of Burst

A world time rack, identical to that used at EPG for the Hardtack shots, was included in the design of the Johnston timing system to record actual zero time with respect to WWVH. This measurement was obtained through the use of a 10-kc oscillator, synchronized to WWVH, which drove the world-time clock. The initial flash of the detonation triggered a fiducial marker on the roof of the CP. This, in turn, stopped the clock and produced a photographic record of the clock face at zero time.

#### 6.4.4 Sandia Rocket Sampling

EG&G installed, controlled, and monitored 14 circuits controlling Sandia's sampling rockets. Two metered circuits were run from the Control Point to each of seven launch stations; two relays ("arm" and "hold") at each Sandia sampling-rocket site were controlled from a keyed switch in the Sandia control area. On shots or dry runs, when the keyed switch was turned to "arm", power was supplied by EG&G to the launch sites at the appropriate time. In the event of a delay in shot time, turning the keyed switch to "hold" prevented battery power from dissipating during the delay.

### 6.5 OPERATION OF COMMUNICATIONS SYSTEM

Voice-time announcements were made from a script by the timing system control operator. Local voice countdown was broadcast on VHF at 153.89 Mc, and on the AOC net at 243 Mc for local ship and aircraft use. For stations operating outside the area covered by these frequencies, the countdown was available at frequencies of 14685 and 7411 kc. This broadcast was in the form of a single-side-band transmission, and was beamed in a generally northeast-southwest direction.

Voice-time receivers at the following stations were installed by EG&G personnel.

Shipboard (2)  
Maui Island  
Hickam Air Force Base  
French Frigate Shoals  
Laulaulai Island  
USS Boxer  
TU-5 (EG&G)

Other projects, located outside the local broadcast area, were able to use standard communications receivers to obtain the voice countdown.

## Chapter 7

### WORLD TIME DETERMINATION

#### 7.1 GENERAL

Time of detonation with respect to world time was obtained from a new type of indicator designed for Operation Hardtack. The new world time indicator employed an electronic interval counter which was started on a known signal and stopped by a fiducial pulse at zero time. The time of detonation could be measured accurately to a millisecond. The new unit, shown in Fig. 7.1, replaced the clock system used on previous operations.



Fig. 7.1 - World-time indicator

#### 7.2 OPERATION

The timing and firing systems at Eniwetok Atoll were served by one world time indicator, and those at Bikini by another. At the conclusion of the test series at Bikini Atoll, the Bikini world time indicator was removed and incorporated in the Johnston Island timing and firing system.

Integration of the timing and firing systems and the world time system was achieved by controlling the sequence timers and the world time indicator from one frequency standard; thus

all timing equipment was referenced to the world time signal broadcast by WWVH, Honolulu, or JJY, Japan. Periodic accuracy checks were made to correct for the inherent drift characteristics of the oscillator.

A schematic diagram of the world-time indicator is given in Fig. 7. 2.

The world time indicator included a Veeder-Root digital counter, driven by the 50-cps output of the world time synchronizer. This counter ran continuously, registering time of day in hours, minutes, and seconds.

For the precise determination of the time of detonation, an electronic interval counter manufactured by Computer Measurements Corporation indicated time in increments of 1.0 sec, 0.1 sec, 0.01 sec, 0.001 sec, and 0.0001 sec on five columns of illuminated digits. An EG&G camera with a polaroid back was mounted on the hinged panel which covered the face of the indicator.

The electronic counter was started on any 2-ppm pulse from the synchronizer unit and stopped by a fiducial pulse generated by the appearance of light from the detonation. Fiducial markers designed to respond with microsecond accuracy to a fast rising light pulse, provided the zero reference signal. The world time fidus were mounted on the 300-ft level of Station 1511 (Eniwetok photo tower) and Station 1510 (Bikini photo tower). Two units, wired in parallel, were employed at each location to provide back-up in case one failed to trigger.

The pulse from the fiducial markers triggered the camera shutter at the same time that it stopped the electronic counter. The time was obtained by addition of the electronic counter reading to the digital counter reading.

On the underwater events, a radio-tone signal transmitted by the radio fiducial system triggered the world time system.

### 7.3 SUMMARY OF RESULTS

Results of the world time determination are listed in Table 7. 1. The times quoted have not been corrected for signal propagation time from WWVH, Honolulu, or JJY, Japan.

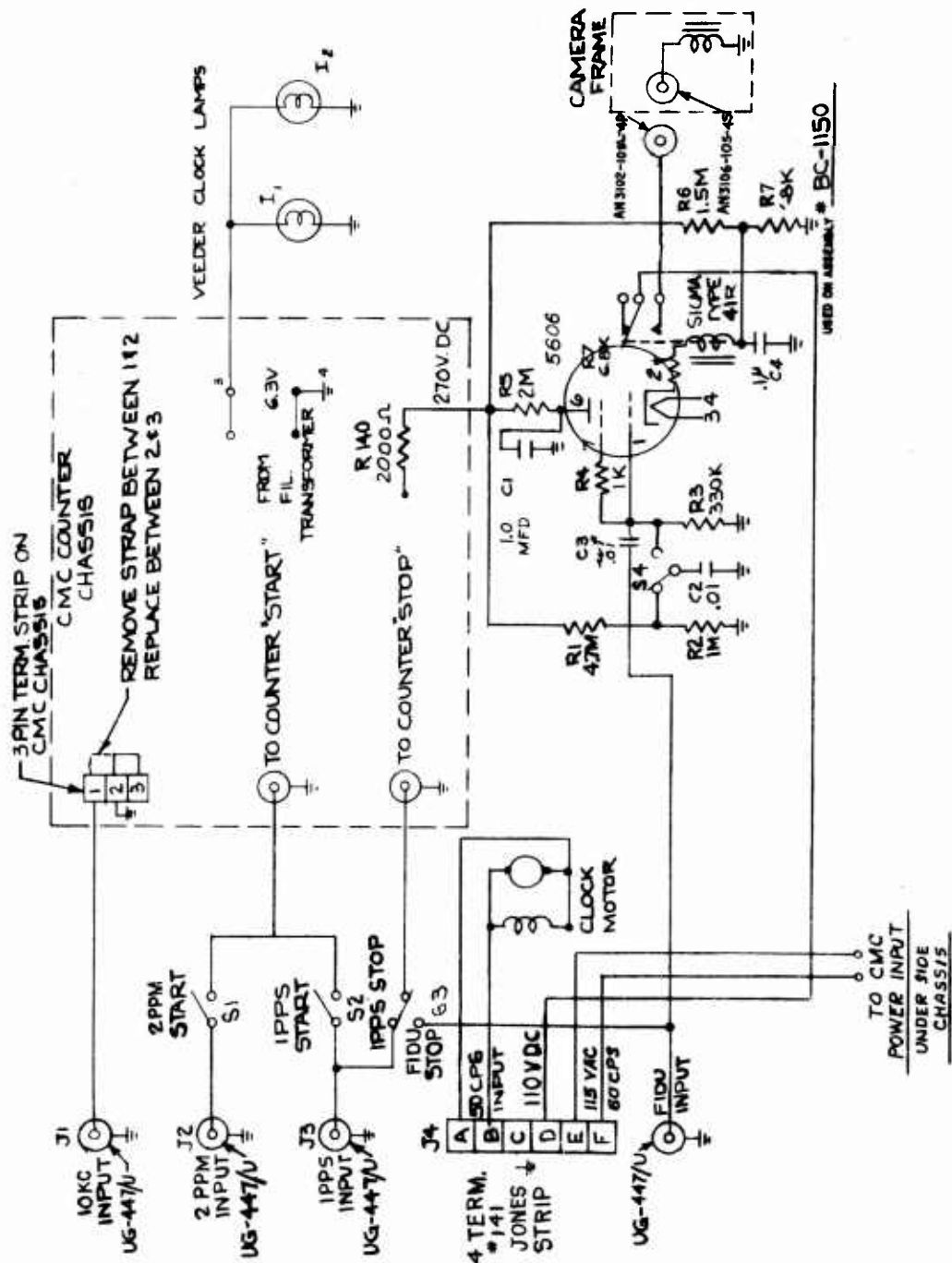

Fig. 7.2 - Schematic diagram of world-time indicator

Table 7.1 - WORLD TIME SUMMARY

Shot Name	Date	Time of Detonation <sup>a</sup>	Station
Yucca	4-28-58	1440:00. 256 ± 2 msec <sup>b</sup>	WWVH (Honolulu)
Cactus	5-6-58	0615:00. 142	
Butternut	5-12-58	0615:00. 113 ± 1 msec <sup>c</sup>	
Fir	5-12-58	0550:00. 148	
Koa	5-13-58	0630:00. 145	
Wahoo	5-16-58	1330:00. 500 ± 100 msec <sup>d</sup>	JJY (Japan)
Holly	5-21-58	0630:00. 145	
Nutmeg	5-22-58	0920:00. 151	
Yellowwood	5-26-58	1400:00. 134	
Magnolia	5-27-58	0600:00. 109	
Tobacco	5-30-58	1415:00. 150	JJY
Sycamore	5-31-58	1500:00. 145	WWVH
Rose	6-3-58	0645:00. 112	JJY
Umbrella	6-9-58	1115:00. 244	JJY
Maple	6-11-58	0530:00. 141	WWVH
Aspen	6-15-58	0530:00. 136	WWVH
Walnut	6-15-58	0630:00. 140	JJY
Linden	6-18-58	1500:00. 116	JJY
Redwood	6-28-58	0530:00. 137	WWVH
Elder	6-28-58	0630:00. 130 ± 20 msec	JJY
Hickory	6-29-58	1200:00. 145	WWVH
Oak	6-29-58	0730:00. 146	JJY
Sequoia	7-2-58	0630:00. 132	JJY
Cedar	7-3-58	0530:00. 136	WWVH
Dogwood	7-6-58	0630:00. 244	JJY
Poplar	7-12-58	1530:00. 141	JJY
Scaevola	7-14-58	1600:00. 130 ± 20 msec <sup>e</sup>	JJY
Pisonia	7-18-58	1100:00. 123	WWVH
Juniper	7-22-58	1620:00. 139	WWVH
Olive	7-23-58	0830:00. 224 ± 5 msec	JJY
Pine	7-27-58	0830:00. 232	WWVH
Teak	7-31-58	2350:05. 596 <sup>f</sup>	WWVH
Quince	8-6-58	1415:00. 180 ± 25 msec <sup>e</sup>	WWVH
Orange	8-11-58	2330:08. 605 <sup>f</sup>	WWVH
Fig	8-18-58	1600:00. 251	WWVH

<sup>a</sup>Eniwetok local time, except as noted; subtract 12 hours for Greenwich Meridian Time (GMT).

<sup>b</sup>Time quoted by National Bureau of Standards: World-time system did not trigger since Yucca position of burst could not be predicted before zero time.

<sup>c</sup>Time quoted by NBS: World-time fidus failed to trigger.

<sup>d</sup>Estimated time: actual clock reading at 1330:00. 955 was considered late.

<sup>e</sup>Estimated time: light intensity insufficient to trigger fidus.

<sup>f</sup>Local time at Johnston Island; add 11 hours for GMT.

COMMUNICATIONS

Communications and radio-signal service to installations in the wide-spread experimental area at both atolls, in addition to the comprehensive radio timing and firing system for the underwater shots, represented a considerable effort in terms of manpower and equipment. Using new and rehabilitated equipment, EG&G operated 17 radio networks, exclusive of those at Johnston Island, and supplied experimenters with receiving equipment as needed. Sixty-watt transmitters were located on the 300-ft levels of Station 1510 (Bikini) and Station 1511 (Eniwetok); 250-watt transmitters were located in the control room on the USS Boxer.

The networks listed in Table 8.1 fall under three general classifications, according to purpose: (1) to permit communication among a number of stations, (2) to provide all users with a voice countdown on all dry run and detonations, and (3) to perform functions equivalent to the standard timing system, including signals and monitoring.

8.1 EG&G COMMUNICATIONS

The EGG nets provided the means of co-ordinating EG&G activity in all areas. Two-way communications were maintained among all stations including Control Points, administrative offices, and stations in the field. An EGG-net microphone and foot-operated keying switch were included on the control console at each control point. All other stations were equipped with Motorola two-way 25-watt transceivers; portable 10-watt pack sets were also available.

The voice-time countdown from the Control Point was patched into the EGG net on all dry and live runs, thus eliminating the necessity for a separate voice-time receiver in each EG&G station.

8.2 VOICE-TIME NETWORKS

EG&G operated five independent voice-time networks to broadcast voice-time announcements to all users on dry runs and detonations. At each atoll one network served the two hardwire systems; a separate network at Eniwetok was for the exclusive use of the DOD-Glenn system. Boxer communications included two voice-time networks, on different frequencies, for local distribution and for long-range broadcasts to Nan.

Upon request, the voice countdown was patched into the following nets:

<u>Eniwetok</u>	<u>Bikini</u>
TU-1 (LASL) Net	TU-1 (LASL) Net
Kleenex (Command) Net	Gaslight (UCRL) Net
TU-4 (Sandia) Net	Harvester (Sandia) Net
AOC (Air Operations Control) Net	Kleenex (Command) Net
	AOC (Air Operations Control) Net
	Tropo (inter-atoll) Net

Control equipment for these nets was located in Control Point timing system racks.

Table 8.1 - COMMUNICATIONS NETS

Location	Voice Net	User	Frequency (Mc)	Signal Nets	User	Frequency (Mc)
Eniwetok	EG&G	EG&G	152.87	Radio-Time No. 1	DOD	157.43
	Voice-Time No. 1	LASL	154.57	Radio-Time No. 2	LASL	158.51
	Voice-Time No. 2	DOD	153.89	Fire No. 1	DOD	157.89
				Fire No. 2	DOD	159.51
				Telemeter	DOD	155.73
				Zero Fidu	DOD	154.71
				Howler	DOD	156.75
Bikini	EG&G	EG&G	152.87	Radio-Time No.2	UCRL-Sandia	158.51
	Voice-Time	UCRL-Sandia	154.57			
USS Boxer	EG&G	EG&G	152.87	Radio-Time	DOD	157.43
	Voice-Time No. 1	(broadcast to Nan)	154.57			
	Special Voice-Time	(broadcast locally)	157.89			

### 8.3 RADIO-TONE NETWORKS

Tone signals were broadcast over several independent radio nets. Three of these nets broadcast timing signals to users in remote locations, thus supplementing the hardwire systems at each atoll and on the Boxer. The radio system for the underwater shots included not only timing signals but also firing signals, zero fiducial signals, and telemeter monitoring signals. The transmitters for the latter two systems were located on the zero barge.

Provision was originally made for remote control of the Bikini CP by radio-tone signals in case total evacuation of the atoll were necessary prior to detonation of a large shot. Three 250-watt transmitters, operating on frequencies of 156.75 Mc, 157.89 Mc, and 159.51 Mc, were installed on board the USS Boxer to transmit timing and firing signals for this purpose, but, following a change in requirements, the project was discontinued.

## DISTRIBUTION

### Military Distribution Category 2

#### ARMY ACTIVITIES

- 1 Deputy Chief of Staff for Military Operations, D/A, Washington 25, D.C. ATTN: Dir. of SM&R
- 2 Chief of Research and Development, D/A, Washington 25, D.C. ATTN: Atomic Div.
- 3 Assistant Chief of Staff, Intelligence, D/A, Washington 25, D.C.
- 4 The Quartermaster General, D/A, Washington 25, D.C. ATTN: Research and Dev.
- 5-6 Chief Chemical Officer, D/A, Washington 25, D.C.
- 7 Chief of Engineers, D/A, Washington 25, D.C. ATTN: ENGNB
- 8 Chief of Engineers, D/A, Washington 25, D.C. ATTN: ENGTB
- 9 Chief Signal Officer, D/A, Comb. Dev. and Ops. Div., Washington 25, D.C. ATTN: SIGCO-4
- 10 Chief of Transportation, D/A, Office of Planning and Int., Washington 25, D.C.
- 11 The Surgeon General, D/A, Washington 25, D.C. ATTN: MEDNE
- 12-13 Commanding General, U.S. Continental Army Command, Ft. Monroe, Va.
- 14 Director of Special Weapons Development Office, Headquarters CONARC, Ft. Bliss, Tex. ATTN: Capt. Chester I. Peterson
- 15 President, U.S. Army Artillery Board, U.S. Continental Army Command, Ft. Sill, Okla.
- 16 President, U.S. Army Air Defense Board, U.S. Continental Army Command, Ft. Bliss, Tex.
- 17 Commanding General, First United States Army, Governor's Island, New York 4, N.Y.
- 18 Commanding General, Second U.S. Army, Ft. George G. Meade, Md.
- 19 Commanding General, Fourth United States Army, Ft. Sam Houston, Tex. ATTN: G-3 Section
- 20 Commanding General, Fifth United States Army, 1660 E. Hyde Park Blvd., Chicago 15, Ill.
- 21 Commanding General, Sixth United States Army, Presidio of San Francisco, San Francisco, Calif. ATTN: AMGCT-4
- 22 Commanding General, Military District of Washington, USA, Room 1543, Bldg. T-7, Gravelly Point, Va.
- 23 Commandant, U.S. Army Command & General Staff College, Ft. Leavenworth, Kansas. ATTN: ARCHIVES
- 24 Commandant, U.S. Army Air Defense School, Ft. Bliss, Tex. ATTN: Dept. of Tactics and Combined Arms
- 25 Commandant, U.S. Army Armored School, Ft. Knox, Ky.
- 26 Commandant, U.S. Army Artillery and Missile School, Ft. Sill, Okla. ATTN: Combat Development Department
- 27 Commandant, U.S. Army Infantry School, Ft. Benning, Ga. ATTN: C.D.S.
- 28 The Superintendent, U.S. Military Academy, West Point, N.Y. ATTN: Prof. of Ordnance
- 29 Commandant, The Quartermaster School, U.S. Army, Ft. Lee, Va. ATTN: Chief, QM Library
- 30 Commandant, U.S. Army Ordnance School, Aberdeen Proving Ground, Md.
- 31 Commandant, U.S. Army Ordnance and Guided Missile School, Redstone Arsenal, Ala.
- 32 Commanding General, Chemical Corps Training Comd., Ft. McClellan, Ala.
- 33 Commandant, USA Signal School, Ft. Monmouth, N.J.
- 34 Commandant, USA Transport School, Ft. Eustis, Va. ATTN: Security and Info. Off.
- 35 Commanding General, The Engineer Center, Ft. Belvoir, Va. ATTN: Asst. Cmdt, Engr. School
- 36 Commanding General, Army Medical Service School, Brooke Army Medical Center, Ft. Sam Houston, Tex.
- 37 Director, Armed Forces Institute of Pathology, Walter Reed Army Med. Center, 625 16th St., NW, Washington 25, D.C.
- 38 Commanding Officer, Army Medical Research Lab., Ft. Knox, Ky.

- 39 Commandant, Walter Reed Army Inst. of Res., Walter Reed Army Medical Center, Washington 25, D.C.
- 40 Commanding General, QM R&D Comd., QM R&D Cntr., Natick, Mass. ATTN: CBR Liaison Officer
- 41 Commanding General, Qm. Research and Engr. Comd., USA, Natick, Mass.
- 42 Commanding General, U.S. Army Chemical Corps, Research and Development Comd., Washington 25, D.C.
- 43 Commanding Officer, Chemical Warfare Lab., Army Chemical Center, Md. ATTN: Tech. Library
- 44 Commanding General, Engineer Research and Dev. Lab., Ft. Belvoir, Va. ATTN: Chief, Tech. Support Branch
- 45 Director, Waterways Experiment Station, P.O. Box 631, Vicksburg, Miss. ATTN: Library
- 46 Commanding Officer, USA Signal R&D Laboratory, Ft. Monmouth, N.J.
- 47 Commanding General, U.S. Army Electronic Proving Ground, Ft. Huachuca, Ariz. ATTN: Tech. Library
- 48 Commanding Officer, USA, Signal R&D Laboratory, Ft. Monmouth, N.J. ATTN: Tech. Doc. Ctr., Evans Area
- 49 Commanding Officer, USA Transportation R&E Comd., Ft. Eustis, Va. ATTN: Chief, Tech. Svcs. Div.
- 50 Director, Operations Research Office, Johns Hopkins University, 6935 Arlington Rd., Bethesda 14, Md.

#### NAVY ACTIVITIES

- 51 Chief of Naval Operations, D/N, Washington 25, D.C. ATTN: OP-75
- 52 Chief of Naval Operations, D/N, Washington 25, D.C. ATTN: OP-91
- 53 Chief of Naval Operations, D/N, Washington 25, D.C. ATTN: OP-92202
- 54-55 Chief of Naval Research, D/N, Washington 25, D.C. ATTN: Code 811
- 56 Chief, Bureau of Aeronautics, D/N, Washington 25, D.C.
- 57 Chief, Bureau of Medicine and Surgery, D/N, Washington 25, D.C. ATTN: Special Wpns. Def. Div.
- 58 Chief, Bureau of Ordnance, D/N, Washington 25, D.C.
- 59 Chief, Bureau of Ships, D/N, Washington 25, D.C. ATTN: Code 423
- 60 Chief, Bureau of Supplies and Accounts, D/N, Washington 25, D.C.
- 61 Chief, Bureau of Yards and Docks, D/N, Washington 25, D.C. ATTN: D-440
- 62 Director, U.S. Naval Research Laboratory, Washington 25, D.C. ATTN: Mrs. Katherine H. Cass
- 63 Commander, U.S. Naval Ordnance Laboratory, White Oak, Silver Spring 19, Md.
- 64 Director, Material Lab. (Code 900), New York Naval Shipyard, Brooklyn 1, N.Y.
- 65 Commanding Officer, U.S. Naval Radiological Defense Laboratory, San Francisco, Calif. ATTN: Tech. Info. Div.
- 66 Officer-in-Charge, U.S. Naval Civil Engineering R&E Lab., U.S. Naval Construction En. Center, Fort Huachuca, Calif. ATTN: Code 753
- 67 President, U.S. Naval War College, Newport, Rhode Island
- 68 Commanding Officer, U.S. Naval Medical Research Institute, National Naval Medical Center, Bethesda, Md.
- 69 Commanding Officer and Director, David W. Taylor Model Basin, Washington 7, D.C. ATTN: Library
- 70 Commander-in-Chief, U.S. Atlantic Fleet, U.S. Naval Base, Norfolk 11, Va.
- 71 Commandant, U.S. Marine Corps, Washington 25, D.C. ATTN: Code A03H
- 72 Commanding General, Fleet Marine Force, Atlantic, Norfolk, Va.

# CONFIDENTIAL

73	Director, U.S.M.C. Development Center, U.S.M.C. Schools, Quantico, Va.	100-102	Commander, Wright Air Development Center, Wright-Patterson AFB, Dayton, Ohio. ATTN: WCOSI
74	Director, U.S.M.C. Educational Center, U.S.M.C. Schools, Quantico, Va.	103-104	Director, USAF Project RAND, VIA: USAF Liaison Office, The RAND Corp., 1700 Main St., Santa Monica, Calif.
75	Commandant, U.S. Coast Guard, 1300 E. St., NW, Washington 25, D.C. ATTN: (OIN)	105	Commander, 3535th Navigator Wing, Mather AFB, Calif.
76	Commander-in-Chief, Pacific, c/o Fleet Post Office, San Francisco, Calif.	106	Commander, Air Technical Intelligence Center, USAF, Wright-Patterson AFB, Ohio. ATTN: AFCIN-4131a, Library
77	Commander-in-Chief, U.S. Pacific Fleet, Fleet Post Office, San Francisco, Calif.		
78	Commanding General, Fleet Marine Force, Pacific, Fleet Post Office, San Francisco, Calif.		
	AIR FORCE ACTIVITIES		
79	Assistant for Atomic Energy, HQ, USAF, Washington 25, D.C. ATTN: DCS/O		
80	Deputy Chief of Staff, Operations HQ, USAF, Washington 25, D.C. ATTN: Operations Analysis		
81-82	Assistant Chief of Staff, Intelligence, HQ, USAF, Washington 25, D.C. ATTN: AFCIN-IB2		
83	Deputy Chief of Staff, Plans and Programs, HQ, USAF, Washington 25, D.C. ATTN: War Plans Division		
84	Director of Research and Development, DCS/D, HQ, USAF, Washington 25, D.C. ATTN: Guidance and Weapons Div.		
85	The Surgeon General, HQ, USAF, Washington 25, D.C. ATTN: Bio-Def. Pre. Med. Division		
86	Commander-in-Chief, Strategic Air Command, Offutt AFB, Neb. ATTN: OAWS		
87	Commander, Tactical Air Command, Langley AFB, Va. ATTN: Doc. Security Branch		
88	Commander, Air Defense Command, Ent AFB, Colorado. ATTN: Atomic Energy Div., ADLAN-A		
89	Commander, Air Force Ballistic Missile Div. HQ, ARDC, Air Force Unit Post Office, Los Angeles 45, Calif. ATTN: WDSOT		
90	Commander, Hq. Air Research and Development Command, Andrews AFB, Washington 25, D.C. ATTN: RDRWA		
91-92	Commander, AF Cambridge Research Center, L. C. Hanscom Field, Bedford, Mass. ATTN: CRQST-2		
93-95	Commander, Air Force Special Weapons Center, Kirtland AFB, Albuquerque, N. Mex. ATTN: Tech. Info. & Intel. Div.		
96-97	Director, Air University Library, Maxwell AFB, Ala.		
98	Commander, Lowry AFB, Denver, Colorado. ATTN: Dept. of Sp. Wpns. Tng.		
99	Commandant, School of Aviation Medicine, USAF, Randolph AFB, Tex. ATTN: Research Secretariat		
		107	Director of Defense Research and Engineering, Washington 25, D.C. ATTN: Tech. Library
		108	Director, Weapons Systems Evaluation Group, Room 1E880, The Pentagon, Washington 25, D.C.
		109-116	Chief, Defense Atomic Support Agency, Washington 25, D.C.
		117	Commander, Field Command, AFSWP, Sandia Base, Albuquerque, N. Mex.
		118	Commander, Field Command, AFSWP, Sandia Base, Albuquerque, N. Mex. ATTN: FCYU
		119-123	Commander, Field Command, AFSWP, Sandia Base, Albuquerque, N. Mex. ATTN: FCWT
		124	Commander, JTF-7, Arlington Hall Station, Arlington 12, Va.
		125	U.S. Documents Officer, Office of the United States National Military Representative - SHAPE, APO 55, New York, N.Y.
			ATOMIC ENERGY COMMISSION ACTIVITIES
		126	Edgerton, Germeshausen and Grier, 160 Brookline Ave., Boston 15, Mass. ATTN: Mr. Herbert E. Grier
		127	Edgerton, Germeshausen and Grier, 1622 South A Street, Las Vegas, Nev. ATTN: Mr. Robert B. Patten
		128-130	U.S. Atomic Energy Commission, Technical Library, Washington 25, D.C. ATTN: For IMA
		131-135	Los Alamos Scientific Laboratory, Report Library, P.O. Box 1663, Los Alamos, N. Mex. ATTN: Helen Redman
		136-140	Sandia Corporation, Classified Document Division, Sandia Base, Albuquerque, N. Mex. ATTN: H. J. Smyth, Jr.
		141-150	University of California Lawrence Radiation Laboratory, P.O. Box 808, Livermore, Calif. ATTN: Clevis G. Craig
		151	Weapon Data Section, Technical Information Service Extension, Oak Ridge, Tenn.
		152-190	Technical Information Service Extension, Oak Ridge, Tenn. (Surplus)

CONFIDENTIAL  
RESTRICTED DATA

RESTRICTED DATA  
CONFIDENTIAL

**UNCLASSIFIED**

**UNCLASSIFIED**