

UNCLASSIFIED

AD NUMBER

AD339031

CLASSIFICATION CHANGES

TO: UNCLASSIFIED

FROM: CONFIDENTIAL

LIMITATION CHANGES

TO:
Approved for public release; distribution is unlimited.

FROM:
Distribution authorized to U.S. Gov't. agencies and their contractors;
Administrative/Operational Use; 15 JUL 1963.
Other requests shall be referred to Office of Naval Research, One Liberty Center, 875 North Randolph Street, Arlington, VA 22203-1995.

AUTHORITY

31 Jul 1975, Group 4, DoDD 5200.10; ONR ltr dtd 4 May 1977

THIS PAGE IS UNCLASSIFIED

UNCLASSIFIED

AD

339031

DEFENSE DOCUMENTATION CENTER

FOR

SCIENTIFIC AND TECHNICAL INFORMATION

CAMERON STATION ALEXANDRIA, VIRGINIA

CLASSIFICATION CHANGED
TO UNCLASSIFIED
FROM CONFIDENTIAL
PER AUTHORITY LISTED IN

TAB 70-10 DATED 15. MAY 1970



UNCLASSIFIED

NOTICE: When government or other drawings, specifications or other data are used for any purpose other than in connection with a definitely related government procurement operation, the U. S. Government thereby incurs no responsibility, nor any obligation whatsoever; and the fact that the Government may have formulated, furnished, or in any way supplied the said drawings, specifications, or other data is not to be regarded by implication or otherwise as in any manner licensing the holder or any other person or corporation, or conveying any rights or permission to manufacture, use or sell any patented invention that may in any way be related thereto.

NOTICE: When government or other drawings, specifications or other data are used for any purpose other than in connection with a definitely related government procurement operation, the U. S. Government thereby incurs no responsibility, nor any obligation whatsoever; and the fact that the Government may have formulated, furnished, or in any way supplied the said drawings, specifications, or other data is not to be regarded by implication or otherwise as in any manner licensing the holder or any other person or corporation, or conveying any rights or permission to manufacture, use or sell any patented invention that may in any way be related thereto.

NOTICE:

THIS DOCUMENT CONTAINS INFORMATION AFFECTING THE NATIONAL DEFENSE OF THE UNITED STATES WITHIN THE MEANING OF THE ESPIONAGE LAWS, TITLE 18, U.S.C., SECTIONS 793 and 794. THE TRANSMISSION OR THE REVELATION OF ITS CONTENTS IN ANY MANNER TO AN UNAUTHORIZED PERSON IS PROHIBITED BY LAW.

CONFIDENTIAL

339031

CATALOGUED BY DDC

339031

AS AD No. _____

DDC
RECEIVED
AUG 8 1963
TISIA A

National Research Corporation

CONFIDENTIAL

CONFIDENTIAL

Project No. 54-1-0226

This document contains
10 pages and 1
figure. This is copy
27 of 177 copies.

Research Division
NATIONAL RESEARCH CORPORATION
70 Memorial Drive
Cambridge 42, Massachusetts

Nonr 3608 (00)
Semi-annual Technical Summary Report
January 1, 1963 - June 30, 1963

THERMODYNAMIC PROPERTIES

OF

BIMETALLIC COMPOUNDS (U)

Mr. Ludwig Fasolino El. 4-5400 Ext. 320

**DOWNGRADED AT 3 YEAR INTERVALS
DECLASSIFIED AFTER 12 YEARS
DOD DIR 5200. 10**

ARPA Order Number: 23-61
Project Code Number: 3910
Contract Date: 15 September 1961
Expiration Date: 14 November 1963
Contract Amount: \$188,819.00

This document contains information affecting the national defense of the United States within the meaning of the Espionage Laws, Title 18, U.S.C., Sections 793 and 794. The transmission or the revelation of its contents in any manner to an unauthorized person is prohibited by law.

Approved by

Allen L. Klibanoff
Program Director

Submitted to:

Director
Advanced Research Projects Agency
The Pentagon, Room 3D-159
Washington 25, D. C.
Attn: Advanced Propellant Chemistry Office

Reviewed by:

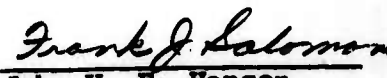
John V. E. Hansen
Contracts Manager
Research Division

July 15, 1963

CONFIDENTIAL

CONFIDENTIAL

- 1 -

TABLE OF CONTENTS

	<u>Page</u>
INTRODUCTION	2
SUMMARY	3
I FEASIBILITY OF SOLUTION CALORIMETRY AS APPLIED TO THE ALUMINUM-BORON SYSTEM	4
II A. ASSEMBLY OF FLUORINE COMBUSTION CALORIMETER	4
B. ELECTRICAL CALIBRATION OF FLUORINE COMBUSTION CALORIMETER	5
III HEAT OF FORMATION OF LiAlH_4	5
IV HEATS OF SOLUTION OF DOWANE-1451, AND OLANE-58	6

CONFIDENTIAL

CONFIDENTIAL

- 2 -

INTRODUCTION

Of interest to the propellant field are several bimetallic materials whose thermochemical characteristics are required for reliable thermodynamic calculations.

This laboratory is devoted toward determining the heats of formation of selected bimetallic compounds by separately measuring the heats of solution (or reaction) of the compound and its separate constituents.

Those materials which are easily reacted with a suitable solvent are studied by a closed bomb solution calorimeter. Higher temperatures may be required for less easily dissolved materials. Materials which cannot feasibly be dissolved must be studied by other techniques. One technique gaining popularity is that of fluorine combustion. The high reactivity of fluorine provides a means of carrying out a reaction whose generated heat may be measured. This laboratory is equipped with both the solution and fluorine combustion calorimeters, thus enabling the study of a large number of compounds.

CONFIDENTIAL

CONFIDENTIAL

- 3 -

SUMMARY

It was shown that the determination of the heat of formation of aluminum dodecaboride (AlB_{12}) by solution calorimetry was not feasible. The method which would most likely be successful in studying the compound is that of fluorine combustion. An apparatus was constructed to handle fluorine and proceed with the combustion of the materials under investigation in a fluorine atmosphere. The combustion calorimeter has been calibrated and is ready for the combustion experiments.

The solution calorimeter has been successfully employed in determining the heat of formation of lithium aluminum hydride. Heats of solution of lithium, aluminum, and lithium aluminum hydride in hydrochloric acid were measured. From this data, the heat of formation of the compound was calculated to be -26.63 ± 0.31 Kcal/mole.

The operation of the solution calorimeter at elevated temperatures ($75^{\circ}C$) was necessary to measure the heat of reaction of aluminum hydride with hydrochloric acid. This was accomplished with satisfactory precision. This work is presently nearing completion.

CONFIDENTIAL

CONFIDENTIAL

- 4 -

I FEASIBILITY OF SOLUTION CALORIMETRY AS APPLIED TO THE ALUMINUM - BORON SYSTEM

Thirty solvent systems were investigated as possible calorimetric fluids at two levels of temperature, 30° and 75°C. Acidic potassium periodate at the higher temperature satisfactorily dissolved powdered boron but was without effect on the aluminum dodecaboride. Of the other 29 solvent systems, none was found to be suitable. It was, therefore, concluded that the thermochemical study of the aluminum-boron system could not feasibly be undertaken by solution calorimetric methods.

Consideration of the other possible techniques has indicated that combustion calorimetry utilizing fluorine as the oxidizer may be the best approach for this particular system.

II A. ASSEMBLY OF THE FLUORINE COMBUSTION CALORIMETER

The decision to undertake the thermochemical study of the aluminum-boron system by fluorine combustion techniques necessitated additional equipment to do so. A special combustion bomb was purchased and a manifold was constructed for charging and discharging the bomb. Figure 1 shows the schematic of the manifold for handling the fluorine gas. In this system the bomb will be pressurized to the desired level, sealed by its valves, removed and

CONFIDENTIAL

CONFIDENTIAL

- 5 -

transferred to the calorimeter in which the combustion will be carried out.

II B. ELECTRICAL CALIBRATION OF FLUORINE COMBUSTION CALORIMETER

A series of electrical calibrations was performed utilizing a 23.21 Ω Cupron heater attached to the electrodes within this bomb. To facilitate the transfer of heat from within the bomb to the calorimeter bucket, 100 ml of water from the bucket was placed within the bomb immersing a major portion of the heater. Since the fluorine had not been delivered as scheduled, the calibrations were made with nitrogen gas within the bomb. The specific heats of these gases are nearly identical and no correction was required. The fluorine gas has since been delivered and combustion runs are planned in the near future. Table I shows the results of the electrical calibration.

III HEAT OF FORMATION OF LiAlH_4

During the initial planning of the fluorine combustion work, instructions were received from ARPA to determine the heat of formation of a compound being prepared by Reaction Motors, Li_2AlH_5 . It was suggested that a preliminary study be made on the analog of this compound, LiAlH_4 , to demonstrate the capabilities of our experimental method. The heat of formation of LiAlH_4 was determined by measuring the heats of solution of lithium, aluminum, and lithium

CONFIDENTIAL

CONFIDENTIAL

- 6 -

aluminum hydride in 4.0 N hydrochloric acid. The reactions were carried out in a closed bomb, thus confining the generated hydrogen. The heat of formation was found to be -26.63 ± 0.31 kcal/mole. The details of this work were written up in a special report and distributed on April 26, 1963, and therefore, will not be repeated here. The Reaction Motors compound, Li_2AlH_5 , has not been received to date. As soon as this is received, its heat of formation will be determined.

IV HEAT OF SOLUTION OF ALUMINUM HYDRIDE

Upon completion of the lithium aluminum hydride work and prior to the delivery of the fluorine gas (difficulty encountered in acquiring the requested cylinder size) a request was made and granted to attempt to measure the heats of solution of Dow's aluminum hydride, Dowane-1451, and/or Olin Mathieson's aluminum hydride, Olane-58. Samples were obtained from the respective companies and preliminary beaker tests were made to determine the conditions of reaction which would allow a meaningful calorimetric study. Both materials were found to react similarly. The conditions finally adopted were as follows:

Solvent = 6.0N hydrochloric acid

Catalyst = chloroplatinic acid (6 drops, 10% solution)

Temperature = 75°C

CONFIDENTIAL

CONFIDENTIAL

- 7 -

Under these conditions, 0.03 gram samples were found to react smoothly and completely within 20 minutes. The final solution was clear with no sign of unreacted material.

The solution calorimeter was then modified to operate under these conditions. A tantalum liner was inserted in the bomb to prevent a side reaction between the solvent and inner bomb walls. The crushing rod and baffle plates were also constructed of tantalum. A 41A1 Veco thermistor was used as the temperature measuring device. Its resistance is approximately 10,000 ohms at 25°C and 1800 ohms at 75°C. The calorimeter bucket liquid and the jacket liquid were changed from water to Bayol-F oil. An immersion heater was placed in the jacket to control its temperature. It was found that the calorimeter jacket could be controlled to $\pm 0.005^\circ\text{C}$ at 75°C as read on the Beckmann thermometer. The calorimeter bucket and bomb temperature had a linear leak rate of approximately $10^{-4}^\circ\text{C min}^{-1}$. The thermistor sensitivity is approximately $5 \times 10^{-5}^\circ\text{C}$.

The system was electrically calibrated and the results are shown in Table II. The heats of solution of aluminum, Olane-58, Dowane-1451 have been measured. The final solutions have always been clear with no residue remaining. Several more runs are required to complete the series. The heats of formation of these compounds will then be calculated. A special report will soon be issued giving the details of this work.

CONFIDENTIAL

CONFIDENTIAL

- 8 -

TABLE I

ELECTRICAL CALIBRATION OF FLUORINE COMBUSTION CALORIMETER

Run No.	Q, cal	$\Delta R, \text{ohms}$	$E = \frac{Q}{\Delta R}, \text{cal ohm}^{-1}$
6	1284.5	36.528	35.150
8	1258.1	35.868	35.093
9	1282.2	36.431	35.194
10	1417.1	40.291	35.171
13	1246.0	35.478	35.120
15	1235.4	35.191	35.106
16	1240.1	35.318	35.113
Mean			35.135
Uncertainty (2 σ)			.028
%			.079

CONFIDENTIAL

CONFIDENTIAL

- 9 -

TABLE II

ELECTRICAL CALIBRATION OF SOLUTION CALORIMETER AT 75°C

Run No.	Q , cal	ΔR , ohms	$E = Q/\Delta R$, cal ohm ⁻¹
1A	285.94	8.609	33.214
2A	285.89	8.750	32.673
3A	281.50	8.629	32.623
4A	215.46	6.556	32.865
5A	297.69	9.614	33.025
Mean			32.880
Uncertainty (2σ)			.220
%			.66

CONFIDENTIAL

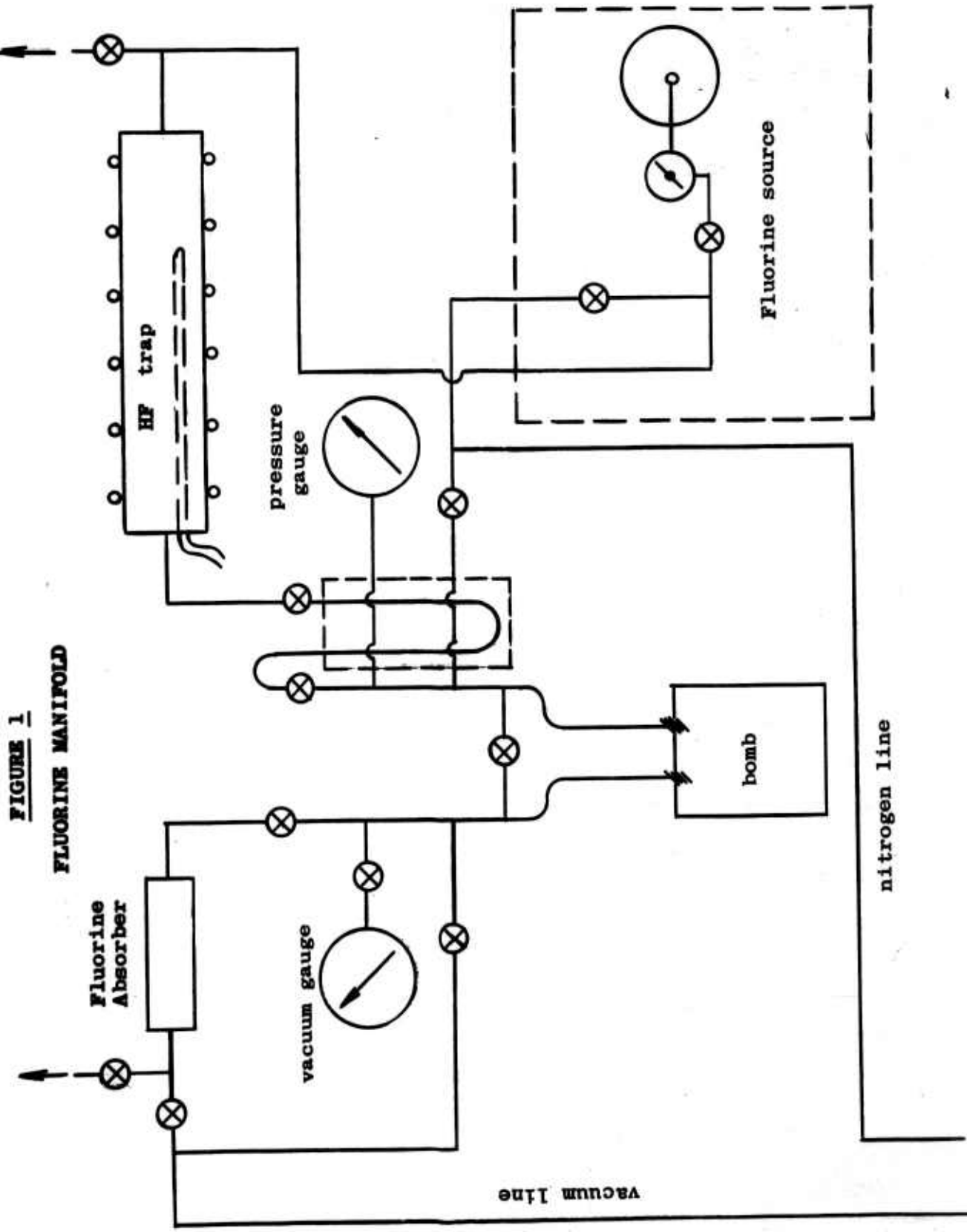

FIGURE 1
FLUORINE MANIFOLD

DISCLASSIFIED

DISCLASSIFIED