

UNCLASSIFIED

<b>AD NUMBER</b>	
<b>AD361147</b>	
<b>CLASSIFICATION CHANGES</b>	
<b>TO:</b>	<b>unclassified</b>
<b>FROM:</b>	<b>confidential</b>
<b>LIMITATION CHANGES</b>	
<b>TO:</b>	<b>Approved for public release, distribution unlimited</b>
<b>FROM:</b>	<b>Distribution authorized to U.S. Gov't. agencies only; Foreign Government Information; MAR 1965. Other requests shall be referred to British Embassy, 3100 Massachusetts Avenue, NW, Washington, DC 20008.</b>
<b>AUTHORITY</b>	
<b>DSTL, AVIA 6/22414, 12 Feb 2009; DSTL, AVIA 6/22414, 12 Feb 2009</b>	

THIS PAGE IS UNCLASSIFIED

**CONFIDENTIAL**

**AD\_ 3 6 1 1 4 7L**

**DEFENSE DOCUMENTATION CENTER**

**FOR**

**SCIENTIFIC AND TECHNICAL INFORMATION**

**CAMERON STATION, ALEXANDRIA, VIRGINIA**



**CONFIDENTIAL**

NOTICE: When government or other drawings, specifications or other data are used for any purpose other than in connection with a definitely related government procurement operation, the U. S. Government thereby incurs no responsibility, nor any obligation whatsoever; and the fact that the Government may have formulated, furnished, or in any way supplied the said drawings, specifications, or other data is not to be regarded by implication or otherwise as in any manner licensing the holder or any other person or corporation, or conveying any rights or permission to manufacture, use or sell any patented invention that may in any way be related thereto.

NOTICE:

THIS DOCUMENT CONTAINS INFORMATION  
AFFECTING THE NATIONAL DEFENSE OF  
THE UNITED STATES WITHIN THE MEAN-  
ING OF THE ESPIONAGE LAWS, TITLE 18,  
U.S.C., SECTIONS 793 and 794. THE  
TRANSMISSION OR THE REVELATION OF  
ITS CONTENTS IN ANY MANNER TO AN  
UNAUTHORIZED PERSON IS PROHIBITED  
BY LAW.

L

361147

CATALOGED BY: DDC

AS AD-118

65045

MARCH

1965

361147L

CONFIDENTIAL

ROYAL AIRCRAFT ESTABLISHMENT

TECHNICAL REPORT No. 65045

INVESTIGATION OF THE  
SUITABILITY OF ROD PROJECTORS  
FOR SIMULATION OF C.R. WARHEAD  
ATTACKS AGAINST FULLY  
EQUIPPED AIRCRAFT TARGETS [c]

by

Sqn. Ldr. S. E. Cowen

1. THIS INFORMATION IS DISCLOSED ON A CONFIDENTIAL BASIS BY THE RECIPIENT GOVERNMENT AND IS SUBJECT TO ANY OTHER GOVERNMENT OR RELEASE TO THE PRESS OR IN ANY OTHER WAY WOULD BE A BREACH OF THIS CONDITION.
2. THE INFORMATION SHOULD BE SAFEGUARDED UNDER RULES WHICH IMPOSE THE SAME STANDARD OF SECURITY AS THAT OBTAINED BY HER MAJESTY'S GOVERNMENT IN THE UNITED KINGDOM.
3. THE INFORMATION CONTAINED IN THIS DOCUMENT SHOULD NOT BE CIRCULATED OUTSIDE GOVERNMENT DEPARTMENTS WITHOUT THE PRIOR PERMISSION OF THE MINISTRY OF AVIATION.
4. THE RECIPIENT IS WARNED THAT INFORMATION CONTAINED IN THIS DOCUMENT MAY BE SUBJECT TO PRIVATELY OWNED RIGHTS.

DDC  
RECEIVED  
JUN 14 1965  
DDC 2

MINISTRY OF AVIATION  
FARNBOROUGH HANTS.

CONFIDENTIAL

EXCLUDED FROM AUTOMATIC  
REGRADING: DOD DIR 5200.10  
DOES NOT APPLY

CONFIDENTIAL

U.D.C. No. 623.451.3:623.42:623.4.082:623 562.5

ROYAL AIRCRAFT ESTABLISHMENT

Technical Report No. 65045

March 1965

INVESTIGATION OF THE SUITABILITY OF ROD PROJECTORS FOR SIMULATION OF  
C.R. WARHEAD ATTACKS AGAINST FULLY EQUIPPED AIRCRAFT TARGETS

by

Sqn. Ldr. S. E. Cowen

SUMMARY

Field trials were made to establish the suitability of rod-projectors, as an alternative to warheads, for a series of continuous-rod firings against fully-equipped aircraft targets to obtain rod penetration data for use in K and C kill assessments.

This Report outlines the conditions of the trials and the main evidence obtained from them. Because of restrictions resulting from the cumbersome screening required to protect targets from projector debris, it was finally decided that warheads should be used in the K and C kill trials, except that a few repeat firings with rod-projectors would be made to establish the difference in penetration at the higher and more realistic impact velocity obtainable with rod-projectors.

**\*This document contains information affecting the National Defense of the United States within the meaning of the Espionage Laws, Title 18, U. S. C., Section 793 and 794. Its transmission or the revelation of its contents in any manner to an unauthorized person is prohibited by law.\***

Departmental Reference: ME413

CONFIDENTIAL

	<u>CONTENTS</u>	<u>Page</u>
1	INTRODUCTION	3
2	OBJECTS	3
3	STORES	4
	3.1 Ammunition	4
	3.2 Targets	4
4	FIRING PROGRAMME	4
	4.1 Target layout	4
	4.2 Instrumentation	5
	4.3 Procedure	5
5	RESULTS	5
6	DISCUSSION OF RESULTS	5
7	CONCLUSIONS	6
	Acknowledgements	7
	Table 1 Results of rod projector firings in RAE trial C.R.17(P)	9
	Illustrations	Figures 1-6
	Detachable abstract cards	-

## 1 INTRODUCTION

1.1 In connection with a planned series of continuous rod attacks, (RAE trials C.R. 17, 18 and 19) against fully equipped aircraft targets, to obtain penetration data for use in K and C kill assessments, the use of rod projectors was considered as an alternative to warheads. Rod projectors were known to be relatively inexpensive and simple to produce. Furthermore, they were believed to be capable of producing representative continuous rod damage, with acceptable accuracy, and a realistic impact velocity of around 4600 fs.

1.2 On the other hand, the large size of the aircraft sections to be used as targets in the first of the trials, C.R.17, and the high elevation of the required strike positions, posed a problem in the protection of the targets from blast and debris. It was clear that a high armour screen would be required, slotted to permit the passage of the projected rod, heavy enough to stop blast and debris from a close explosion, and requiring a robust support structure. It was inevitable that this structure would be damaged, and would require repair and re-erection after each firing. Provision of only one such screen was considered possible, and it would not easily be movable.

1.3 It was also desired to minimize the movement of aircraft targets, especially after rod strikes had occurred. But a single target layout with a static armour screen would seem to require a considerable amount of target movement, simply to achieve the alignment of each new strike position.

1.4 It was finally agreed that the feasibility of using rod projectors could only be decided from experience gained in a demonstration trial. For this purpose, four attacks by rod-projectors against a Valiant fuselage were arranged. The programme for this investigation - RAE trial C.R.17 P - was issued under reference ME3/9092/1/SEC dated 25th May 1964 and the firings made at P & EE, Shoeburyness on the 23rd, 24th, 25th and 26th of June 1964. This Report outlines the conditions and results of the demonstration firings, and the conclusions drawn from them.

1.5 The rod-projectors used in the demonstration firings were designed and provisioned by RARDE, Potton Island.

## 2 OBJECTS

It was required to investigate:-

(a) The signature pattern and limits of accuracy of rod strikes from projector firings.

(b) Problems in the method of mounting and sighting the projector.

(c) The feasibility of protecting the target from rod-projector debris by a slotted armour screen.

(d) The overall rate of strike which might be expected.

### 3 STORES

#### 3.1 Ammunition

A total of four rod-projectors was used, two of 5 ft and two of 7 ft rod length. (For details of rod projector design see RARDE Branch Memo L5/3/58.) Each consisted of a square section rectangular wooden box, one long face of which was made up of a central  $\frac{1}{4}$ "  $\times$   $\frac{1}{4}$ " mild steel rod of the nominal length, together with  $\frac{1}{4}$ " mild steel plates on each side, and a short length of  $\frac{1}{4}$ "  $\times$   $\frac{1}{4}$ " mild steel rod at each end. The box was filled with high-explosive. Sighting was by means of a metal tube and crossed-wires for aim in azimuth, and by a calculated "lay-off" or inclination for elevation. Detonation was initiated electrically at one end, which was placed uppermost. All five elements of the metal face were projected at small angles of divergence by the explosion, and it was necessary to stop the side plates and end rods, without interfering with the horizontal trajectory of the central rod.

#### 3.2 Targets

A Valiant fuselage in two sections was used. The targets were of typical semi-monocoque, stressed-skin and stringer construction, and comprised:-

(a) Target A, the forward portion, 14 ft long.

(b) Target B, the rear portion, 20 ft long.

Both targets were simply supported at two points, Target A on a wooden cradle, Target B on concrete blocks.

### 4 FIRING PROGRAMME

#### 4.1 Target layout

The target layout for all four firings was generally as shown in Fig.1, and illustrated photographically in Figs.2, 3, 4(a), 5(a) and 6(a). Such amendments as were made to the layout, between rounds, are mentioned in section 4.3.

The armour screen (Figs.4(b), (c) and (d)), measuring 16 ft  $\times$  10 ft  $\times$  2 in was mounted vertically on a steel rail braced structure set in holes in

the concrete. Extra support and protection were provided by sandbag side walls, (which were omitted for firing 4). The rod-projector was mounted on end, on a wooden stand, and inclined backwards at a calculated "lay-off" angle to fire through a 10 ft x 8 inch vertical slot in the armour plate; the effective length of this slot was adjusted by sandbagging for each individual rod-projector. Inclination of the projector was necessary to ensure that, with initiation of the H.E. detonation from one end of the projector box, the rod would reach the target in a vertical attitude with a horizontal trajectory.

#### 4.2 Instrumentation

The rod velocities were measured at two points in the trajectory by microsecond counter chromometers, using two foil "make" probes at 12 ft, and two at 6 ft, from the target. The mean observed velocity was used as a basis for estimating each strike velocity. Fastax ciné cameras were also used as a check on the observed velocities.

#### 4.3 Procedure

4.3.1 Aircraft Target A, and the armour screen and rod projector mounting, were erected in readiness for the first firing during the few days preceding the trial. The setting up of the instrumentation, and mounting and sighting the rod-projector, were completed on the day of the first firing. Because the armour screen was a fixed element, only one target layout could be considered at a time. For each subsequent firing the preparations were planned and effected with the object of firing the round as soon as possible.

4.3.2 After the third firing, it was decided that the sandbagging around the armour screen support structure should be omitted for firing No.4, in order to discover whether it was really necessary.

4.3.3 Additionally, in order to investigate the effects of blast and debris on an aircraft target of sufficient length to project beyond the shielding effect of the armour screen without sandbag side walls, an extra aircraft target was placed in line with the major axis of the primary target for firing No.4 (Fig.6(a)).

### 5 RESULTS

5.1 The results of the rod projector firings are given in Table 1.

### 6 DISCUSSION OF RESULTS

6.1 The signature pattern of the rod strikes was reasonably straight. Accuracy of the strikes was within acceptable limits, and responded to small adjustment of aim.

6.2 The methods employed for mounting and sighting the rod projectors were simple and effective.

6.3 The slotted armour screen was effective in protecting the target from damage by debris and blast, while permitting the rod to pass to the target. Its use involved several considerable disadvantages, however. Its size and bulk necessitated a fixed structure, and precluded its movement to other target layouts which could have been prepared in advance. The armour plate sustained severe gouging on the explosion side, from the impact of the rod-projector guard plates, and it was considered that at least the area immediately around the slot would have required replacement or reinforcing after one more firing. Thus any longer firing programme would have been delayed. Finally, the need to rebuild the sandbag protection of the support structure after each firing was a major factor in the time taken to prepare for the next firing.

6.4 Removal of the sandbag screen in firing No.4 resulted in severe damage to the armour plate support structure and partial displacement of the plate from its attachment to this support structure. No positive evidence of blast or debris damage was produced on the primary target but the secondary target was slightly dished by blast. The primary target did, in fact crumple and roll toward the firing point, but close inspection led to the opinion that this was caused by the rod strike isolating the unbraced section of the target immediately over the left hand support allowing it to collapse with a rolling effect. It is considered possible that blast effects contributed to this dislodgement.

6.5 The rate of strike achieved over the time between the firing of round 1 and the firing of round 3 was one per 24 hours approximately. The preparation time for round 1 was neglected since this work was performed under ordinary working routine in ample time. The time taken to recover after round 3 and prepare for round 4 was also neglected because this was done with the deliberate object of erecting a simplified structure for the armour screen, which in the event proved unrealistic. Finally, the time taken to recover after round 4 was not observed, since it was not performed under trial conditions.

## 7 CONCLUSIONS

7.1 From the evidence obtained in the four firings, it was concluded that under the conditions imposed:-

- (a) The signature pattern, and the accuracy of strike, from rod-projectors can be fully satisfactory.
- (b) The mounting and sighting of the rod-projector presents no serious difficulty.
- (c) The necessary use of a heavy, and very firmly mounted armour screen, to protect the target from projector débris, is a serious drawback to the convenient use of rod-projectors for the type of trial envisaged.
- (d) The rate of striking achievable with the type of layout used in the demonstration, is too low to be acceptable except for, possibly, a few special requirements.
- (e) The use of sandbag walls around the armour screen is essential to prevent damage to the armour screen support structure and target, and further depresses the rate of firing.

7.2 In view of the foregoing conclusions, it was decided that C.R. warheads would be used for RAE trials C.R.17, 18 and 19, except that a few rod-projectors - say 5 or 6 - would be used, in some repeat strikes, to establish the difference in rod débris penetration at the higher and more realistic impact velocity obtainable with projectors, i.e. approximately 4600 fs, against 3600 fs with warheads.

#### ACKNOWLEDGEMENTS

The help provided by the Staffs of the Director, RARDE, in providing the necessary rod-projectors, and of the Superintendent, P & EE Shoeburyness, in carrying out the firings for the demonstration, is acknowledged with thanks.

---

Table 1

RESULTS OF ROD PROJECTOR FIRINGS IN

Date	Round No.	Stand-off distance	Estimated impact velocity fs	Vertical inaccuracy of strike	Horizontal inaccuracy of strike			Target	Height of centre of target above GL
					Top	Mid	Bottom		
23.6.64	1 (5 ft rod)	27.7 ft	N.O.	7 inch low	4½" L	1" L	4½" L	A	9.29 ft
24.6.64	2 (7 ft rod)	27.7 ft	4590	1.25 inch low	0	6" L	1" L	A	9.27 ft
25.6.64	3 (5 ft rod)	28.0 ft	4620	2 inch low	8" L	1" L	2" R	B	6.92 ft
26.6.64	4 (7 ft rod)	28.0 ft	4620	2 inch low	0	2½" L	0	B	6.92 ft

1/

Table 1

RESULTS OF ROD PROJECTOR FIRINGS IN RAE TRIAL C.R.17(P)

Horizontal inaccuracy of strike		Target	Height of centre of target above GL	Approximate target section diameter	Length of cut (circumferential)	Length of cut (projected)	Results
Mid	Bottom						
1" L	4½" L	A	9.29 ft	10.83 ft	5.92 ft	5.0 ft	Target skin and 14 "Z" section stringers and 2 "U" section stringers out. Armour plate gouged. Sandbagging of armour screen destroyed. (Bottom 3 ft of slot in armour plate blanked off).
6" L	1" L	A	9.27 ft	10.42 ft	8.67 ft	6.42 ft	Target skin and 27 "Z" section stringers and 2 "U" section stringers out. Sandbagging of armour screen destroyed, plate gouged, and joints in support structure fractured. (Bottom 2 ft of slot in armour plate blanked off).
1" L	2" R	B	6.92 ft	9.08 ft	6.5 ft	4.08 ft	Target skin and 22 "Z" section stringers and 2 "U" section stringers out. Sandbagging of armour screen destroyed. (Top 2 ft 10 in, and bottom 1 ft of slot blanked off).
2½" L	O	B	6.92 ft	10.08 ft	8.21 ft	6.83 ft	All sandbags removed. The section of target above the left hand support point collapsed when isolated by rod out. Target rolled off supports with considerable crumpling. Blast effects may have contributed to this. Extensive damage to armour screen support structure from blast. The supplementary target was slightly dished.

2

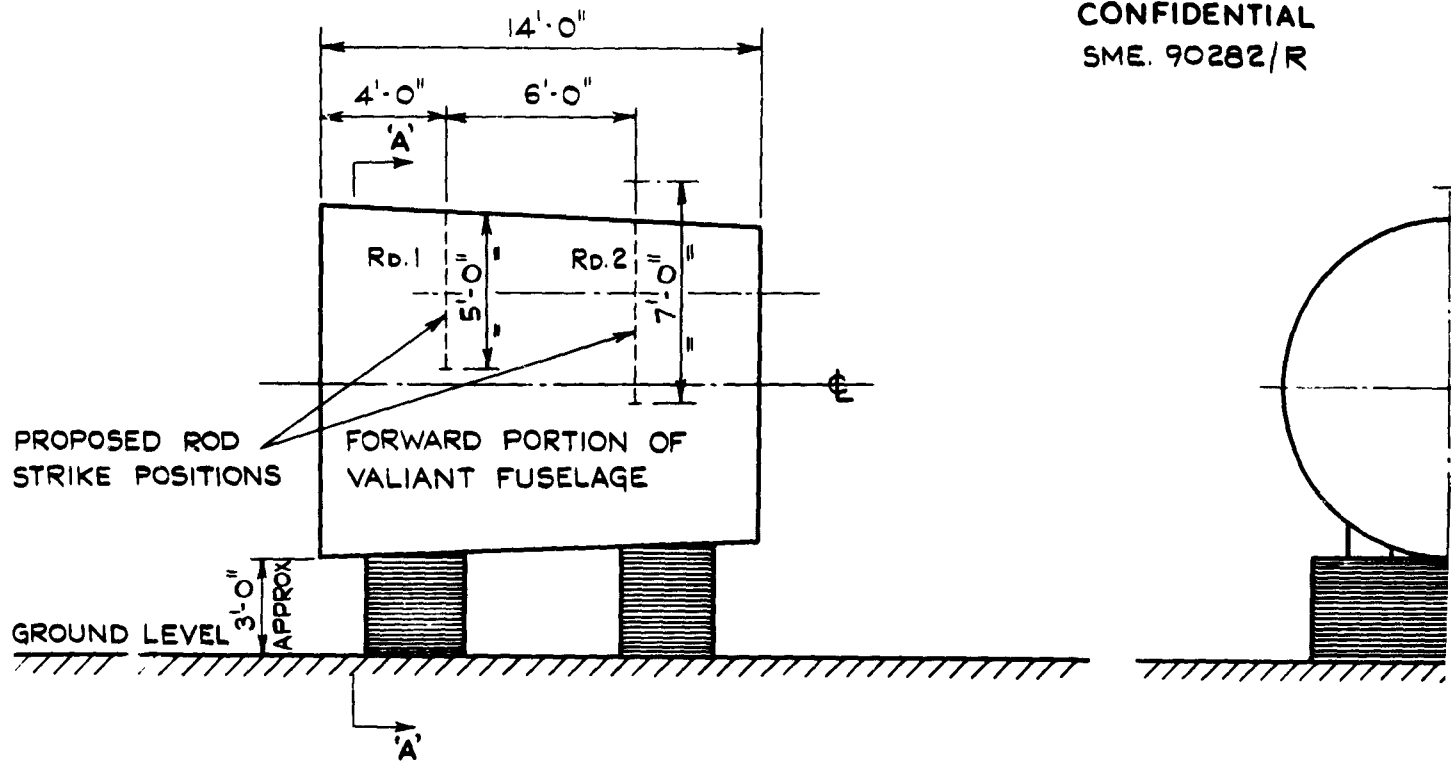

SIDE ELEVATION SHOWING POSITIONS OF PROPOSED STRIKES FOR ROUNDS 1 AND 2

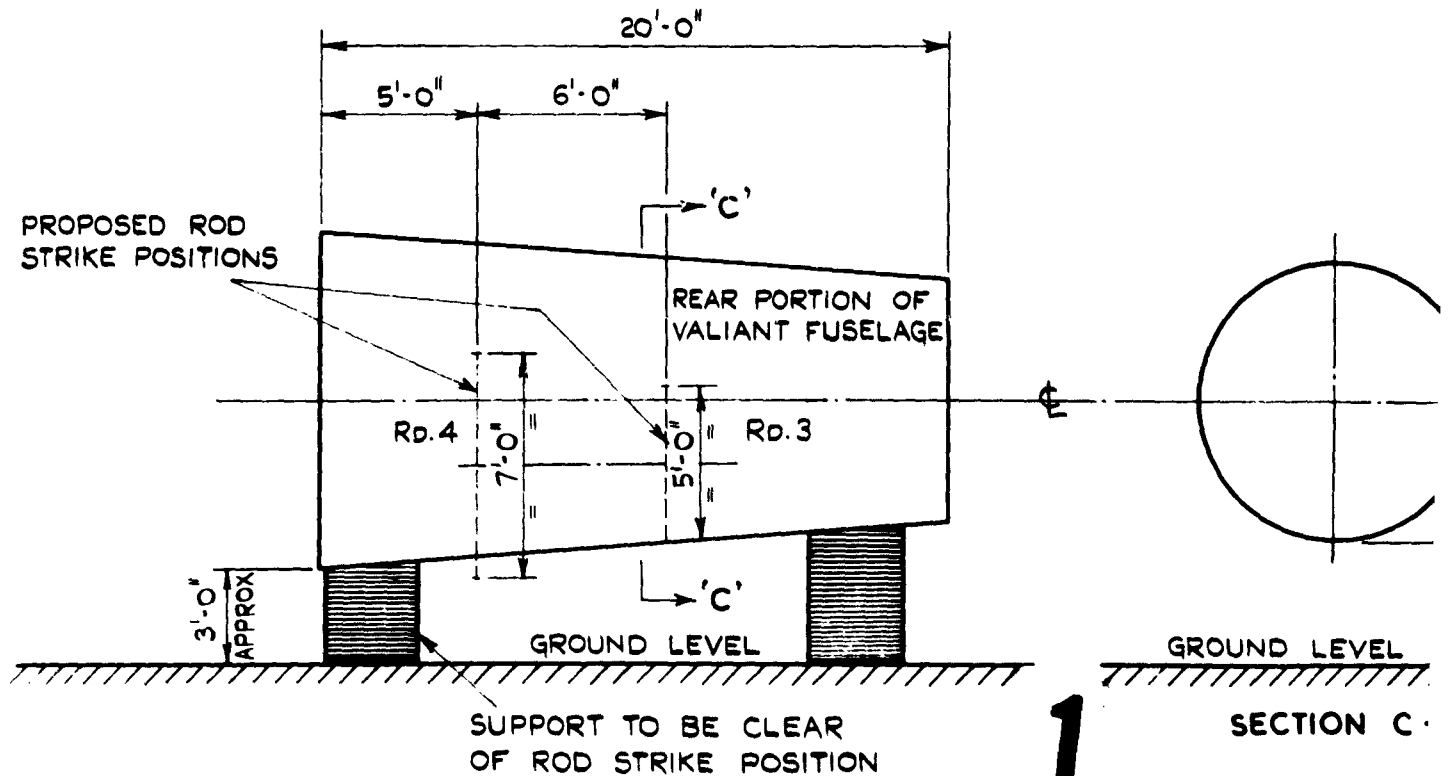

SIDE ELEVATION SHOWING POSITIONS OF PROPOSED STRIKES FOR ROUNDS 3 & 4

FIG.1 DETAILS OF LAYOUT FOR ROD PROJECTOR REHE

CONFIDENTIAL  
SME. 90282/R

Fig.1

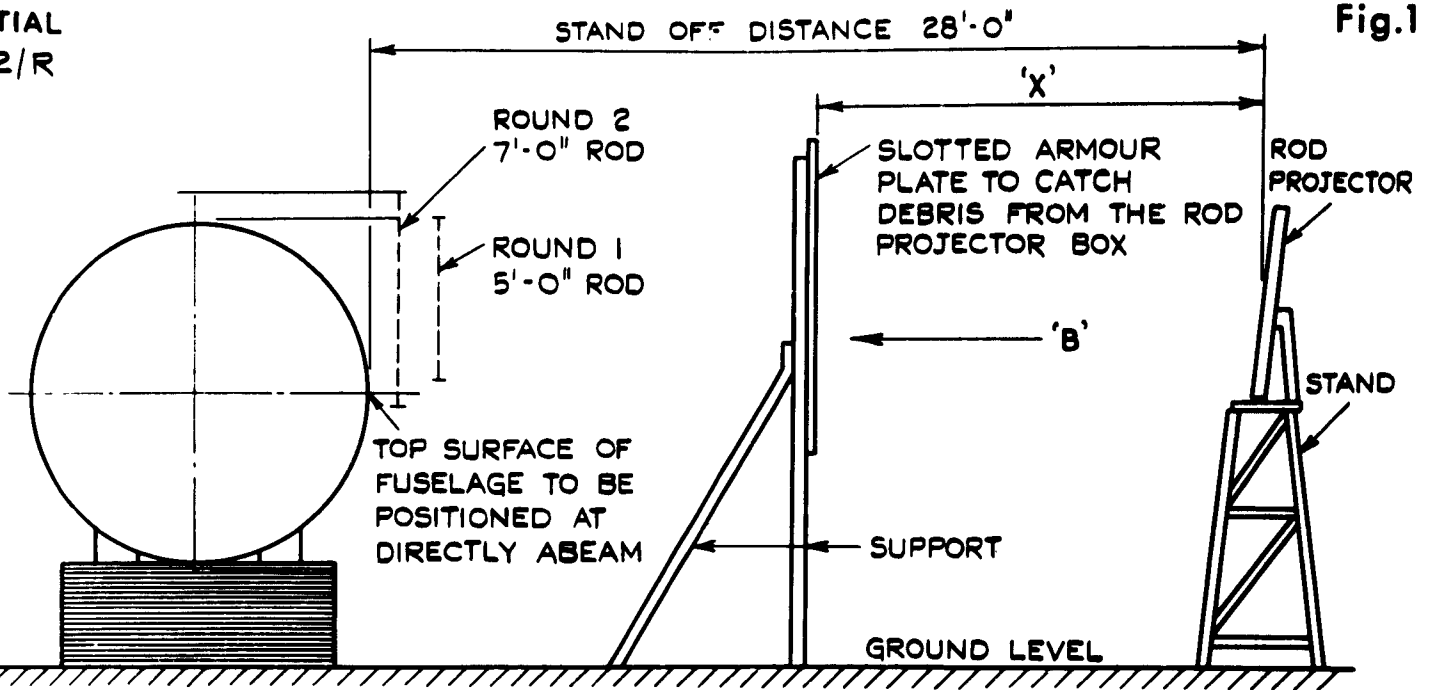

SECTION A - A

NOTE:- THIS LAYOUT WILL BE SIMILAR FOR ROUNDS 1,2,3 AND 4 DIMENSIONS 'X','Y' & 'Z' TO BE SPECIFIED BY R.A.R.D.E. POTTON ISLAND.

SED

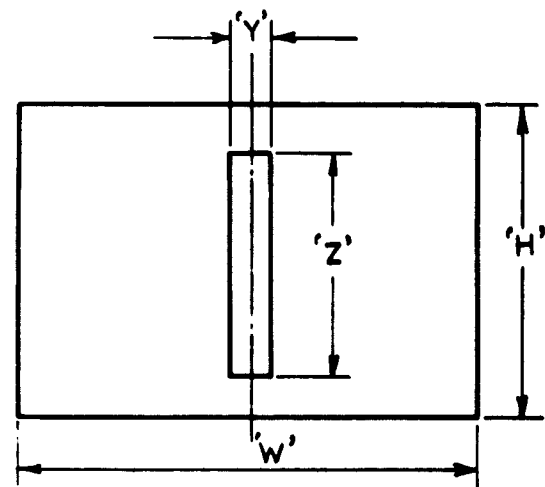
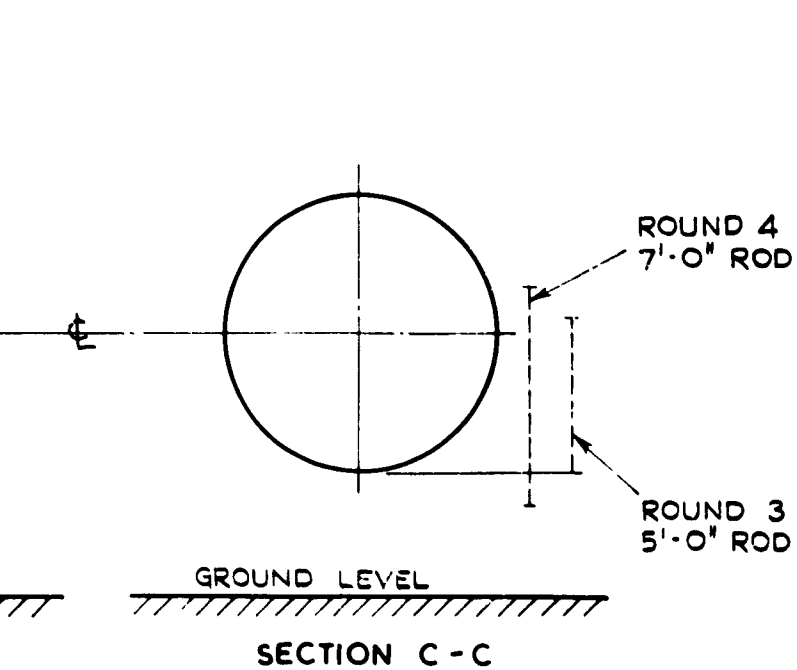

VIEW ON ARROW 'B' SHOWING SLOTTED ARMOUR PLATE. DIMENSIONS 'H' AND 'W' TO BE SPECIFIED BY P. & E.E. SHOE BURYNESS.

2

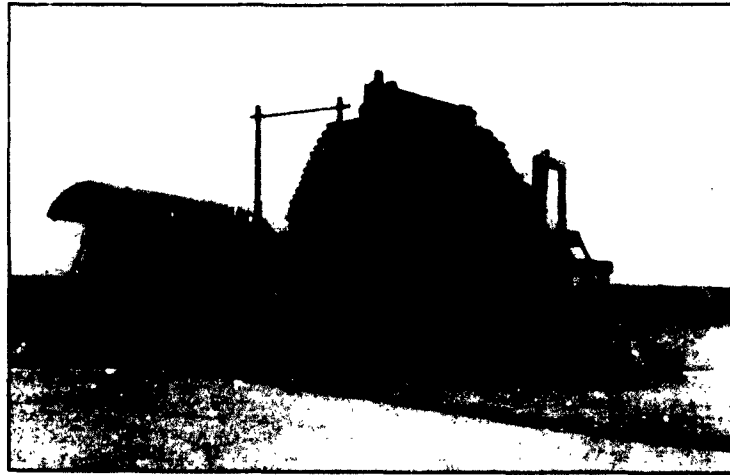

**Fig.2 View of typical Target Layout before firing**



**Fig.3 Rod projector mounted in firing position**

Fig.4 a - b

**CONFIDENTIAL**  
C303

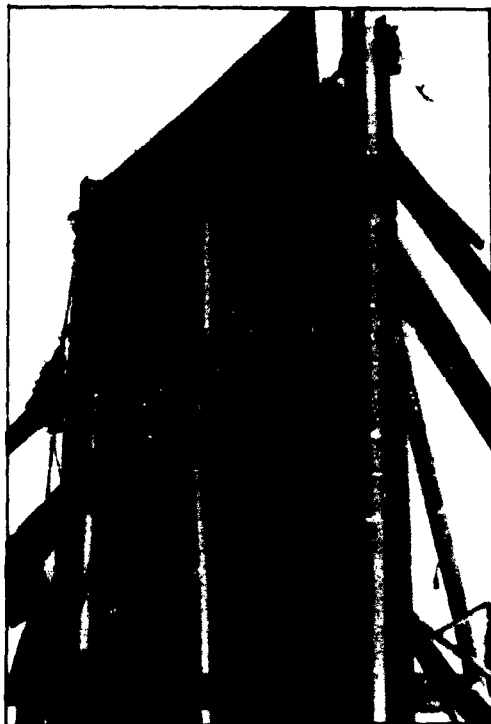

**Fig.4a. Target A before firing Round 2**



**Fig.4b. Explosion side of Armour Screen after firing Round 2**

**CONFIDENTIAL**



**Fig.4c. Damage on explosion side of armour screen after firing Round 1,2,3 and 4**



**Fig.4d. Close-up of damage on explosion side of armour screen after firing Round 1**

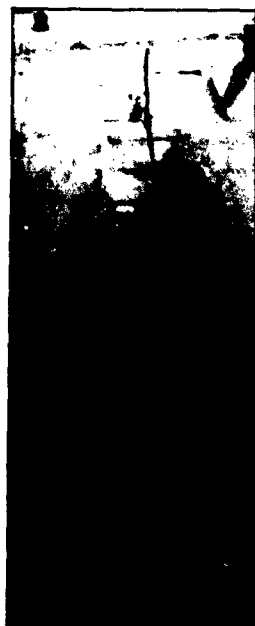

**Fig.4e. Rod damage to Target A after firing Round 1**

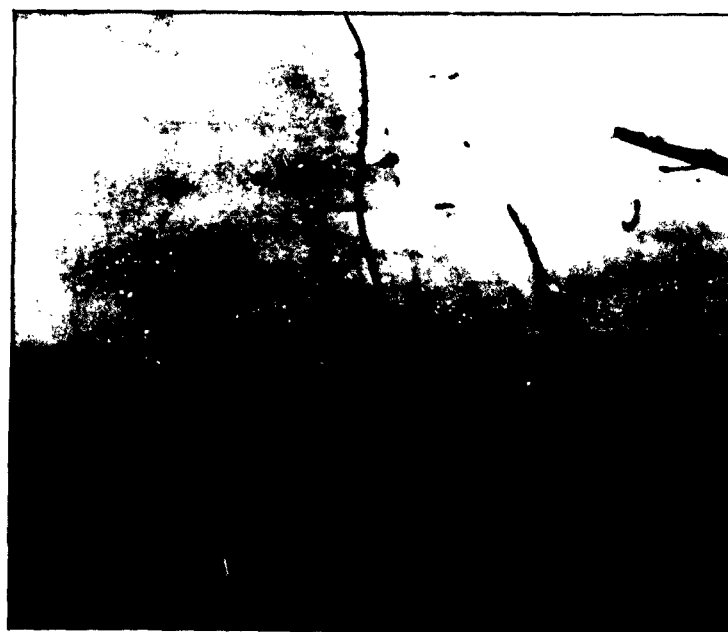

**Fig.4f. Rod damage to Target A after firing Round 2**

Fig.5 a - b

**CONFIDENTIAL**  
C305

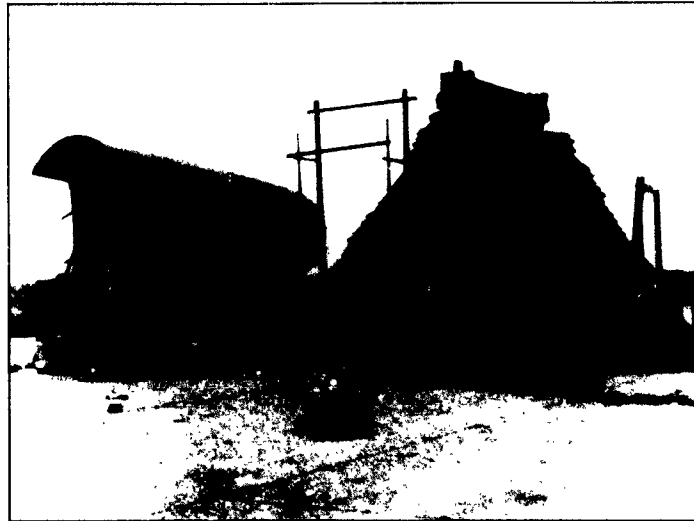

**Fig.5a. Layout for Round 3, Target B before firing**

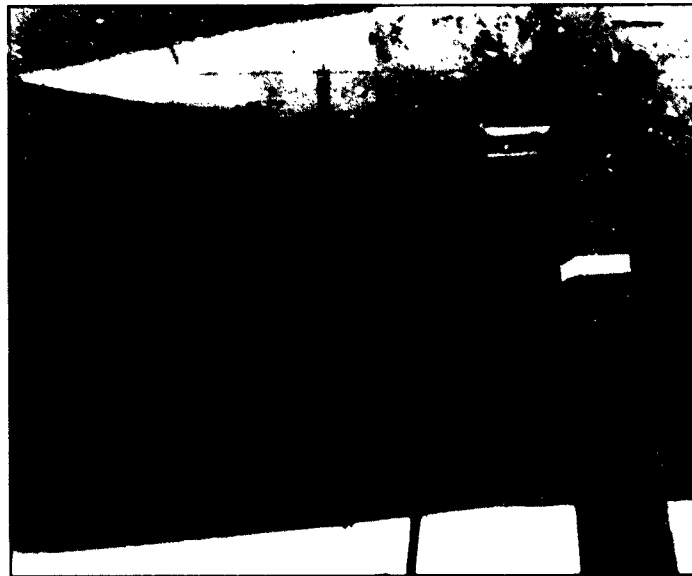
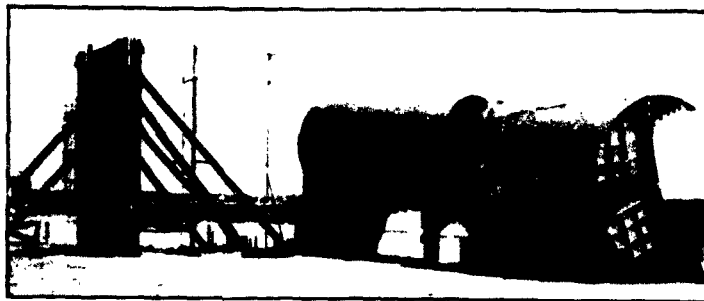

**Fig.5b. Rod damage to Target B after firing Round 3**

**CONFIDENTIAL**

**CONFIDENTIAL**  
C306

Fig.6 a - c



**Fig.6a. Target B Layout for Round 4 before firing.  
Note extra 'Target' in nearer position**

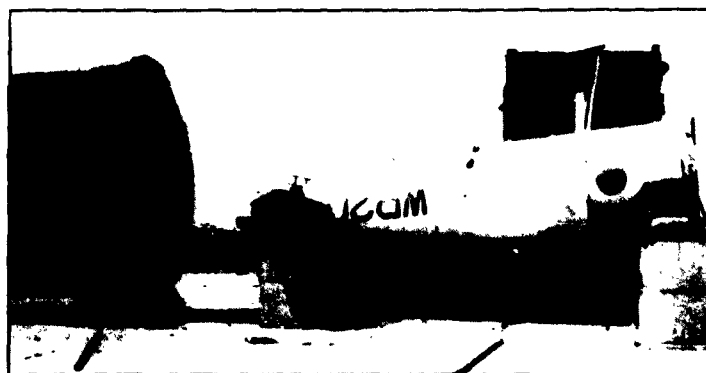

**Fig.6b. General view of collapsed Target B  
after firing Round 4**



**Fig.6c. Close-up of collapsed Target B  
after firing Round 4**

**CONFIDENTIAL**

DETACHABLE ABSTRACT CARDS

These abstract cards are inserted in Technical Reports for the convenience of librarians and others who need to maintain an Information Index.

Detached cards are subject to the same Security Regulations as the parent document, and a record of their location should be made on the inside of the back cover of the parent document.

<p style="text-align: center;">CONFIDENTIAL</p> <p>Cowen, Sqm. Ldr. S.E.</p> <p>INVESTIGATION OF THE SUITABILITY OF ROD PROJECTORS FOR SIMULATION OF C.R. WARHEAD ATTACKS AGAINST FULLY EQUIPPED AIRCRAFT TARGETS</p> <p>Royal Aircraft Establishment Technical Report 66045</p> <p>March 1966</p> <p>Field trials were made to establish the suitability of rod-projectors, as an alternative to warheads, for a series of continuous-rod firings against fully-equipped aircraft targets to obtain rod penetration data for use in K and C kill assessments.</p> <p>This Report outlines the conditions of the trials and the main evidence obtained from them. Because of restrictions resulting from the cumbersome screening required to protect targets from projector debris, it was finally decided that warheads should be used in the K and C kill trials, except that a few repeat firings with rod-projectors would be made to establish the difference in penetration at the higher and more realistic impact velocity obtainable with rod-projectors.</p> <p style="text-align: center;">CONFIDENTIAL</p>	<p style="text-align: center;">CONFIDENTIAL</p> <p>Cowen, Sqm. Ldr. S.E.</p> <p>INVESTIGATION OF THE SUITABILITY OF ROD PROJECTORS FOR SIMULATION OF C.R. WARHEAD ATTACKS AGAINST FULLY EQUIPPED AIRCRAFT TARGETS</p> <p>Royal Aircraft Establishment Technical Report 66045</p> <p>March 1966</p> <p>Field trials were made to establish the suitability of rod-projectors, as an alternative to warheads, for a series of continuous-rod firings against fully-equipped aircraft targets to obtain rod penetration data for use in K and C kill assessments.</p> <p>This Report outlines the conditions of the trials and the main evidence obtained from them. Because of restrictions resulting from the cumbersome screening required to protect targets from projector debris, it was finally decided that warheads should be used in the K and C kill trials, except that a few repeat firings with rod-projectors would be made to establish the difference in penetration at the higher and more realistic impact velocity obtainable with rod-projectors.</p> <p style="text-align: center;">CONFIDENTIAL</p>
<p style="text-align: center;">CONFIDENTIAL</p> <p>Cowen, Sqm. Ldr. S.E.</p> <p>INVESTIGATION OF THE SUITABILITY OF ROD PROJECTORS FOR SIMULATION OF C.R. WARHEAD ATTACKS AGAINST FULLY EQUIPPED AIRCRAFT TARGETS</p> <p>Royal Aircraft Establishment Technical Report 66045</p> <p>March 1966</p> <p>Field trials were made to establish the suitability of rod-projectors, as an alternative to warheads, for a series of continuous-rod firings against fully-equipped aircraft targets to obtain rod penetration data for use in K and C kill assessments.</p> <p>This Report outlines the conditions of the trials and the main evidence obtained from them. Because of restrictions resulting from the cumbersome screening required to protect targets from projector debris, it was finally decided that warheads should be used in the K and C kill trials, except that a few repeat firings with rod-projectors would be made to establish the difference in penetration at the higher and more realistic impact velocity obtainable with rod-projectors.</p> <p style="text-align: center;">CONFIDENTIAL</p>	<p style="text-align: center;">CONFIDENTIAL</p> <p>Cowen, Sqm. Ldr. S.E.</p> <p>INVESTIGATION OF THE SUITABILITY OF ROD PROJECTORS FOR SIMULATION OF C.R. WARHEAD ATTACKS AGAINST FULLY EQUIPPED AIRCRAFT TARGETS</p> <p>Royal Aircraft Establishment Technical Report 66045</p> <p>March 1966</p> <p>Field trials were made to establish the suitability of rod-projectors, as an alternative to warheads, for a series of continuous-rod firings against fully-equipped aircraft targets to obtain rod penetration data for use in K and C kill assessments.</p> <p>This Report outlines the conditions of the trials and the main evidence obtained from them. Because of restrictions resulting from the cumbersome screening required to protect targets from projector debris, it was finally decided that warheads should be used in the K and C kill trials, except that a few repeat firings with rod-projectors would be made to establish the difference in penetration at the higher and more realistic impact velocity obtainable with rod-projectors.</p> <p style="text-align: center;">CONFIDENTIAL</p>



*Information Centre  
Knowledge Services*  
**[dstl]** Porton Down  
Salisbury  
Wilt  
SP4 0JQ  
22060-6218  
Tel: 01980-613753  
Fax: 01980-613970

Defense Technical Information Center (DTIC)  
8725 John J. Kingman Road, Suit 0944  
Fort Belvoir, VA 22060-6218  
U.S.A.

AD#: AD361147

Date of Search: 12 February 2009

Record Summary: AVIA 6/22414

Investigation of suitability of rod projectors for simulation of CR warhead attacks against fully equipped aircraft targets  
Former reference (Department): TECHNICAL REPORTS 65045  
Held by The National Archives, Kew

This document is now available at the National Archives, Kew, Surrey, United Kingdom.

DTIC has checked the National Archives Catalogue website (<http://www.nationalarchives.gov.uk>) and found the document is available and releasable to the public.

Access to UK public records is governed by statute, namely the Public Records Act, 1958, and the Public Records Act, 1967.  
The document has been released under the 30 year rule.  
(The vast majority of records selected for permanent preservation are made available to the public when they are 30 years old. This is commonly referred to as the 30 year rule and was established by the Public Records Act of 1967).

This document may be treated as **UNLIMITED**.