

UNCLASSIFIED

AD NUMBER

AD366004

CLASSIFICATION CHANGES

TO: unclassified

FROM: confidential

LIMITATION CHANGES

TO:
Approved for public release, distribution unlimited

FROM:
Distribution authorized to U.S. Gov't. agencies and their contractors; Administrative/Operational Use; 30 JAN 1956. Other requests shall be referred to Department of the Army, Attn: Public Affairs Office, Washington, DC 20310.

AUTHORITY

USAMC ltr, 26 Mar 1981; USAMC ltr, 26 Mar 1981

THIS PAGE IS UNCLASSIFIED

AD- 366004

SECURITY REMARKING REQUIREMENTS ●

DOD 5200.1-R, DEC 78

REVIEW ON 30 JAN 76

CONFIDENTIAL

AD 366004

CLASSIFICATION CHANGED

TO: CONFIDENTIAL

FROM: UNCLASSIFIED

AUTHORITY:

179 1300C



CONFIDENTIAL

THIS REPORT HAS BEEN DELIMITED
AND CLEARED FOR PUBLIC RELEASE
UNDER DOD DIRECTIVE 5200.20 AND
NO RESTRICTIONS ARE IMPOSED UPON
ITS USE AND DISCLOSURE.

DISTRIBUTION STATEMENT A

APPROVED FOR PUBLIC RELEASE;
DISTRIBUTION UNLIMITED.

SECURITY

MARKING

The classified or limited status of this report applies to each page, unless otherwise marked.
Separate page printouts **MUST** be marked accordingly.

THIS DOCUMENT CONTAINS INFORMATION AFFECTING THE NATIONAL DEFENSE OF THE UNITED STATES WITHIN THE MEANING OF THE ESPIONAGE LAWS, TITLE 18, U.S.C., SECTIONS 793 AND 794. THE TRANSMISSION OR THE REVELATION OF ITS CONTENTS IN ANY MANNER TO AN UNAUTHORIZED PERSON IS PROHIBITED BY LAW.

NOTICE: When government or other drawings, specifications or other data are used for any purpose other than in connection with a definitely related government procurement operation, the U. S. Government thereby incurs no responsibility, nor any obligation whatsoever; and the fact that the Government may have formulated, furnished, or in any way supplied the said drawings, specifications, or other data is not to be regarded by implication or otherwise as in any manner licensing the holder or any other person or corporation, or conveying any rights or permission to manufacture, use or sell any patented invention that may in any way be related thereto.

AD 366004

6 **PLATO**

ANTI-MISSILE MISSILE PROGRAM XSAM-19, PHASE II(U)

SEP DOC 2-18-34A
DATE 3/12/56 INITIAL BFB

~~PLATO~~

9 QUARTERLY REPORT, NO. 9, 1 Oct - 30 Dec 55.

REPORTING PERIOD: OCTOBER 1 - DECEMBER 30, 1955

15 ARMY ORDNANCE CONTRACT DA 301069-ORD-1166

This document contains information affecting the national defense of the United States within the meaning of the Espionage Laws, Title 18, U.S.C., Sections 793 and 794. Its transmission or the revelation of its contents in any manner to an unauthorized person is prohibited by law.

January 30, 1956

16 7735
Approved

DDC CONTROL NO 54635

11 30 JAN 56,
12 25p

Sherrill B Miller
Manager

B

SYLVANIA ELECTRIC PRODUCTS INC.
MISSILE SYSTEMS LABORATORY
WALTHAM, MASSACHUSETTS

339100

CONFIDENTIAL

TABLE OF CONTENTS

SECTION		PAGE NO.
1	OBJECTIVE	1
2	SUMMARY	3
3	EXPERIMENTAL PROGRAM ON THE ACQUISITION RADAR	5
	3.1 INTRODUCTION	5
	3.2 DISCUSSION OF SUB-TASK OBJECTIVES AND PROGRESS	6
	3.2.1 SUB-TASK ONE - TRANSMITTER AND MODULATOR	6
	3.2.1.1 Exciter-Driver Chain	6
	3.2.1.2 High Power Work	12
	3.2.1.3 Work For Next Reporting Period	13
	3.2.2 SUB-TASK TWO - EXPERIMENTAL ANTENNAS	14
	3.2.3 SUB-TASK THREE - RECEIVER AND INDICATOR	14
	3.2.3.1 Receiver	15
	3.2.3.2 Indicator	17
	3.2.3.3 Equipment For The Measurement Of Stability	17
	3.2.3.4 Work For Next Reporting Period	18
	3.2.4 SUB-TASK FOUR - ANTENNA RESEARCH	18
	3.2.5 SUB-TASK FIVE - ELECTRO-MECHANICAL SCANNER FOR TRANSMITTER ANTENNA	19
	3.2.6 SUB-TASK SIX - RECEIVER PHASING MATRIX	20
APPENDICES		
1	BIOGRAPHICAL SKETCHES OF TECHNICAL PERSONNEL	21
11	CONFERENCES	25

CONFIDENTIAL

57AA 40131

SECRET

SECTION I
OBJECTIVE

The Objectives of Project PLATO are:

1. Phase I (8 September 1953 to 1 February 1955)
 - (a) To summarize the performance characteristics of foreign missiles to be expected in the near future.
 - (b) To review and evaluate previous counter missile efforts.
 - (c) To estimate the essential features and numerical constants of a guided anti-missile system.
 - (d) To establish a preliminary guided anti-missile missile system design with estimates of its effectiveness and costs.
2. Phase II (1 February 1955 to 1 February 1956)
 - (a) To determine quantitatively the benefits to be attained from improving certain system performance characteristics and the cost involved.
 - (b) To prepare an adequate description of a preliminary design which can be put into construction over a period of the next several years.
 - (c) To prepare a program necessary to achieve an engineering design of a guided anti-missile missile prototype system.
3. Experimental Acquisition Radar Program (26 August 1955 to 26 February 1956)
 - (a) Initiate the design of an experimental version of the acquisition radar.
 - (b) Initiate detailed electrical design, experiments, and bench testing on certain critical components and circuits that must be added to provide a tracking capability for missile tracking experiments and tests with other PLATO subsystems.

SECRET

SECRET

SECTION 2

SUMMARY

This is submitted to satisfy the requirements of ARTICLE I 5(b) of Contract No DA-30-069-ORD-1166 for a quarterly report of progress on Project PLATO for the period 1 October 1955 through 31 December 1955. Section 3 describes the progress on the acquisition radar experimental program. The detailed description of all other technical accomplishments during this period will be included in the Phase II Final Report, which will be issued during the next quarter. The administrative aspects of progress have been separately covered in the 3 monthly reports issued during this period.

SECRET

SECRET

SECTION 3

EXPERIMENTAL PROGRAM ON THE ACQUISITION RADAR

3.1 INTRODUCTION

A six-month extension to contract DA-30-069-ORD-1166 dated 26 August 1955 provided for the initiation of design work on certain major radio frequency components of the PLATO defense system acquisition radar. This six-month program covers only the initial phase of a longer term experimental program which has as its objectives:

1. The design and construction of an experimental non-scanning version of the acquisition radar. This experimental radar, operating at very high power with fixed high gain transmitter and receiver beams, would be used:
 - a. to furnish data on its ability to detect intermediate range ballistic missiles.
 - b. to gather data on meteoric and ionospheric clutter to confirm theoretical predictions.
2. The detailed electrical design, experiments, bench testing, and construction of certain critical components and circuits which must be added to the non-scanning experimental radar to provide:
 - a. a tracking capability for ballistic missile tracking experiments.
 - b. an experimental acquisition radar for use in field tests of the PLATO defensive system.

The initial phase of this experimental program is organized into six Sub-Tasks:

- Sub-Task One - Transmitter and Modulator
- Sub-Task Two - Experimental Antennas
- Sub-Task Three - Receiver and Indicator
- Sub-Task Four - Antenna Research
- Sub-Task Five - Electro-mechanical Scanner for Transmitter Antenna
- Sub-Task Six - Receiver Phasing Matrix

SECRET

5

SECRET

The majority of the engineering effort during the initial phase of this program is being devoted to the work of Sub-Task One because of the importance of an early determination of a satisfactory transmitter design. Progress during the period 26 August 1955 to 1 January 1956 and plans for the remainder of the authorized period are reported in the following sections by Sub-Tasks.

3.2 DISCUSSION OF SUB-TASK OBJECTIVES AND PROGRESS

3.2.1 SUB-TASK ONE - TRANSMITTER AND MODULATOR

This Sub-Task covers the investigation of techniques suitable for providing very high peak and average radiated power, and the design and construction of experimental components of the transmitter chain and its associated modulator. This includes the design and initial experimental construction of an exciter unit, driver chain and two power amplifiers with appropriate modulators. This Sub-Task can lead to the design and construction of an experimental transmitter for use in field and missile range tests.

It is necessary to provide very high peak and average powers and at the same time to provide proper power level and phasing for each antenna element. A promising method is to perform power dividing and phasing operations at low level (using, for example, an electro-mechanical phase shifter). One would then use these phased outputs to drive separate power amplifiers, each of which feed one or more antenna elements (Figure 1). This method has been selected for initial emphasis because it offers the quickest means of getting an experimental radar on the air. In addition, there are several expected advantages in field applications, namely:

- a. The problem of handling r.f. power at very high peak levels in rotating joints, power dividers, phasing elements, and transmission lines is avoided.
- b. Power-amplifier vacuum tubes capable of supplying the required individual element power are available in advanced development. Single tubes which can produce the total transmitter peak power do not exist.
- c. The use of one "super" modulator with attendant problems of voltage breakdown, size and handling is avoided. A "super" modulator would probably also require a hydrogen thyratron or ignitron development.
- d. The transmitter can be composed of identical modules each containing a power amplifier-modulator combination.

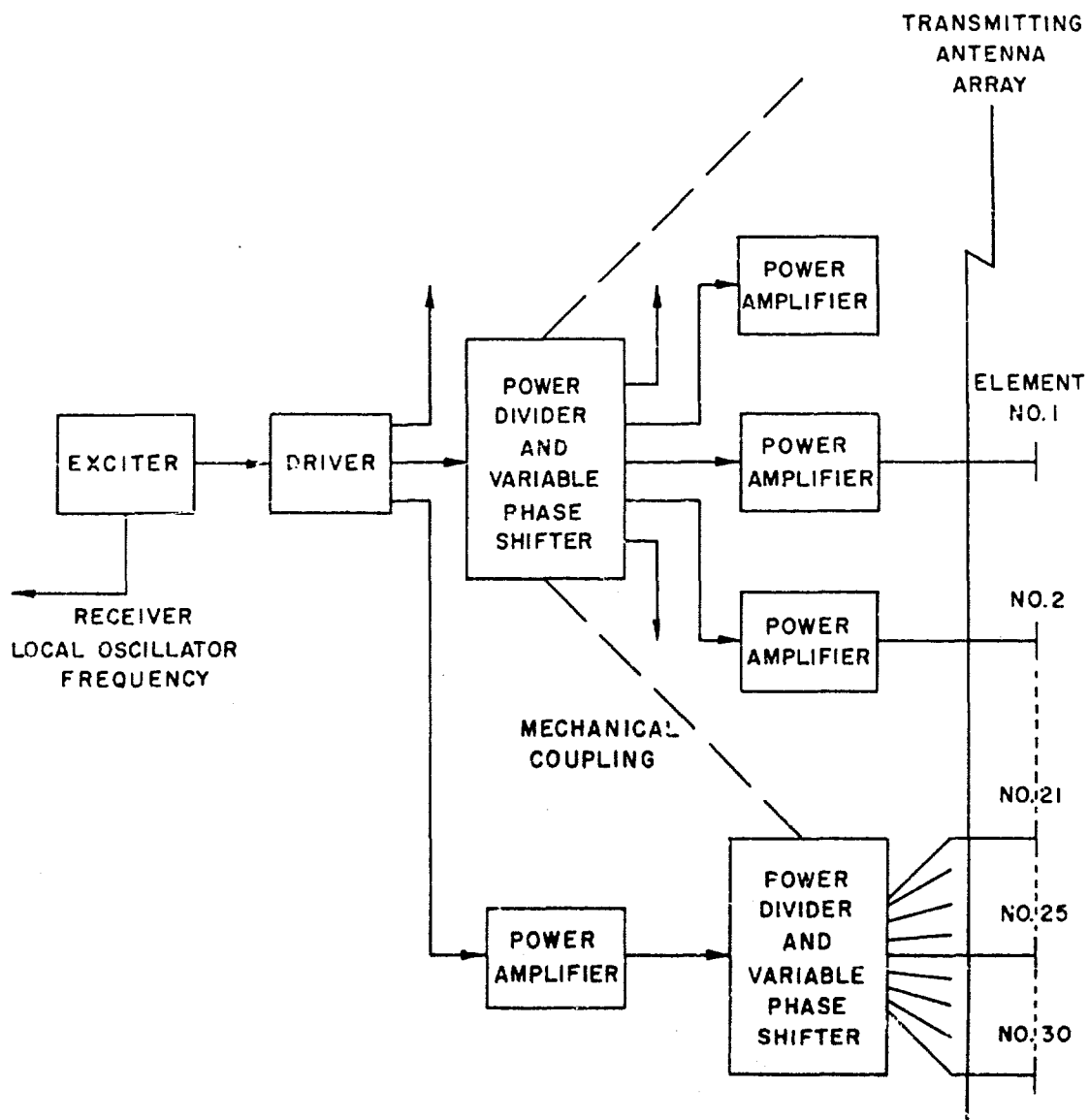

FIGURE 1. ACQUISITION RADAR TRANSMITTER USING LOW LEVEL PHASING

SECRET

This approach offers attendant transport, logistical and maintenance advantages.

- e. The reliability of the radar will be higher since the failure of one, or even several, individual amplifiers will reduce radar range and increase side lobe response only slightly, while the failure of a single very high power amplifier in the alternate transmitter configuration would render the radar completely inoperative.

An immediate question to be explored in connection with the low-level power-dividing and phasing method is the possible problem of phase stability in the individual power amplifiers. Initial attention to this question will enable an early determination of the suitability of the low level phasing approach.

Sub-Task One is therefore oriented towards obtaining the answer to the phase-stability question as soon as possible. To explore this thoroughly, the design and experimental construction of this Sub-Task is concentrated on the exciter unit, driver chain, and two power amplifiers with modulator as shown in Figure 2.

As a result of our recent survey of high-power transmitting-tubes (reported in Phase II PLATO Quarterly Progress Report No. 8), it has been decided to use the RCA type A2515, a UHF beam power tetrode now in advanced development, as the power amplifier tube in the two final amplifier stages for the phase stability tests. Objective ratings and discussions with RCA development engineers on the A2515 indicate that it should have a power gain of at least 20 db and be capable of about 0.5 megawatt when operating with a pulse length of 60 microseconds and a 0.006 duty factor.

The design of the exciter unit and driver chain is to reflect the driving power requirements of two A2515 power amplifiers. The pulse modulator equipment for the high power amplifiers is to be designed for use with the RCA type A2515.

3.2.1.1 Exciter-Driver Chain

Since the basic function of the exciter-driver chain combination is to provide properly timed pulses of r.f. energy at a level sufficient to drive the two A2515 power amplifier stages which are to be evaluated, a master signal source is being designed and built containing the following components: exciter, synchronizer, driver, hard tube modulator and power supplies. These five units will be rack mounted in two standard relay racks with suitable interconnections.

SECRET

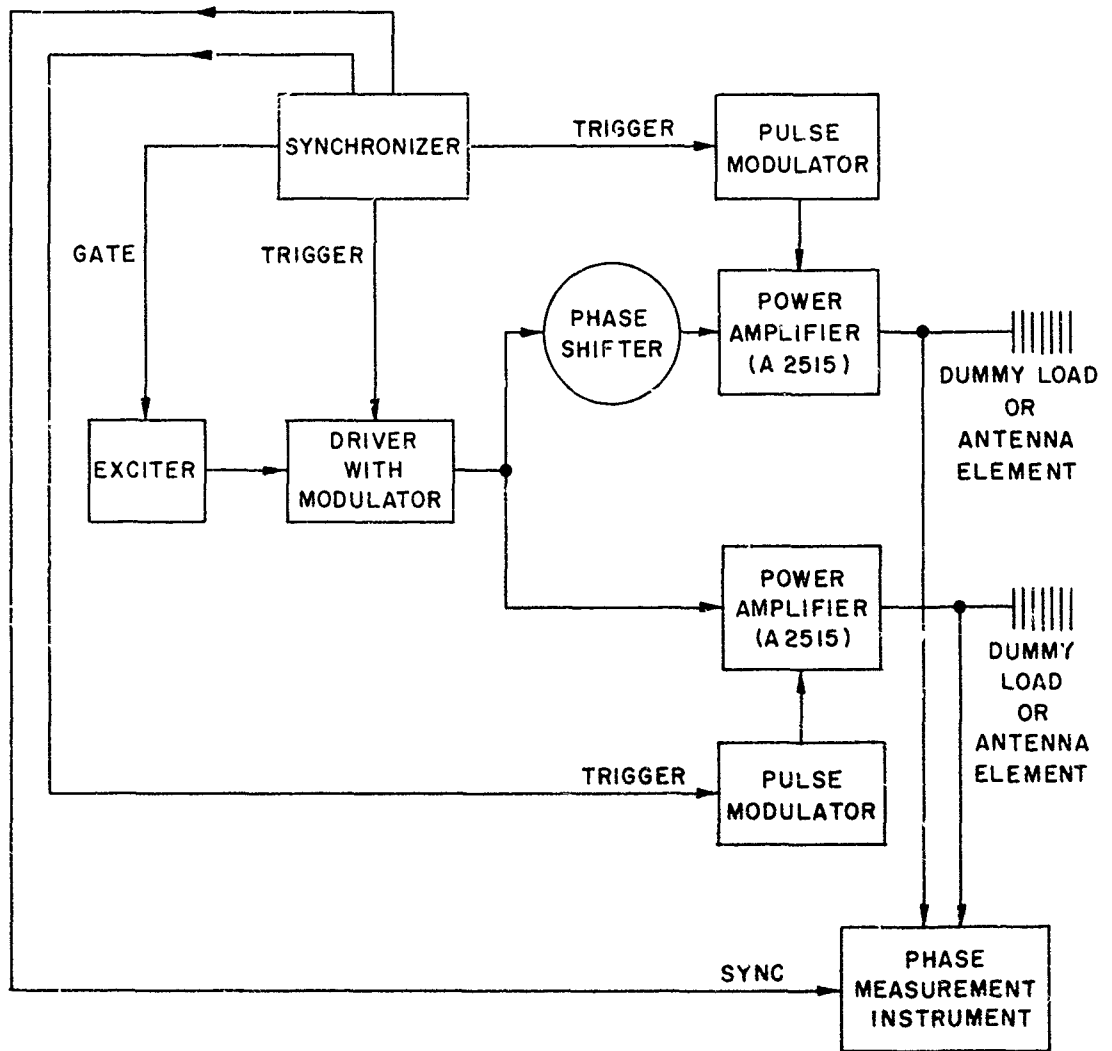

FIGURE 2. PHASE STABILITY MEASUREMENT SYSTEM

SECRET

SECRET

exciter Unit

This unit will provide a stable 235-megacycle*, 60-microsecond pulse of approximately five watts peak power to the driver, and a receiver local oscillator output at 205 megacycles C.W.

The block diagram of this unit is shown in Figure 3. A breadboard has been built and about 85% of the parameters have been optimized.

Material for a laboratory model has been ordered and the layout on paper has been completed.

Synchronizer

The synchronizer unit consists of a P.R.F. generator, overdriven amplifier and blocking oscillator plus appropriate variable delay circuits. Four outputs will be provided: main triggers to the soft tube modulator for the A2515 power amplifiers, trigger to the hard tube modulator in the driver, and a timing output for receiver gating or general use.

A breadboard has been built and the circuit parameters are being optimized.

Driver

Two pulsed power-amplifier stages employing 4X250B's will be cascaded to produce approximately 35 db power gain at 235 megacycles with a peak power output of approximately 20 kilowatts. No information is available on peak cathode emission or peak anode voltage when the 4X250B is operated with long pulses; namely, 60 microseconds with a duty factor of 0.006. In order to determine the suitability of the 4X250B in this type of service an experiment is being performed to evaluate the emission properties of the oxide-coated cathode under long pulse conditions. In this test, the tube is operated as a switch tube in a breadboard hard tube modulator and measurements of cathode current as a function of pulse length are being made.

Hard Tube Modulator For Driver Stages

The hard tube modulator will pulse the exciter-driver units and will have outputs at three different levels. These outputs will plate modulate

.....
* The frequencies stated in this report are only approximate since a definite frequency assignment for the experimental work on the acquisition radar has not yet been authorized.

SECRET

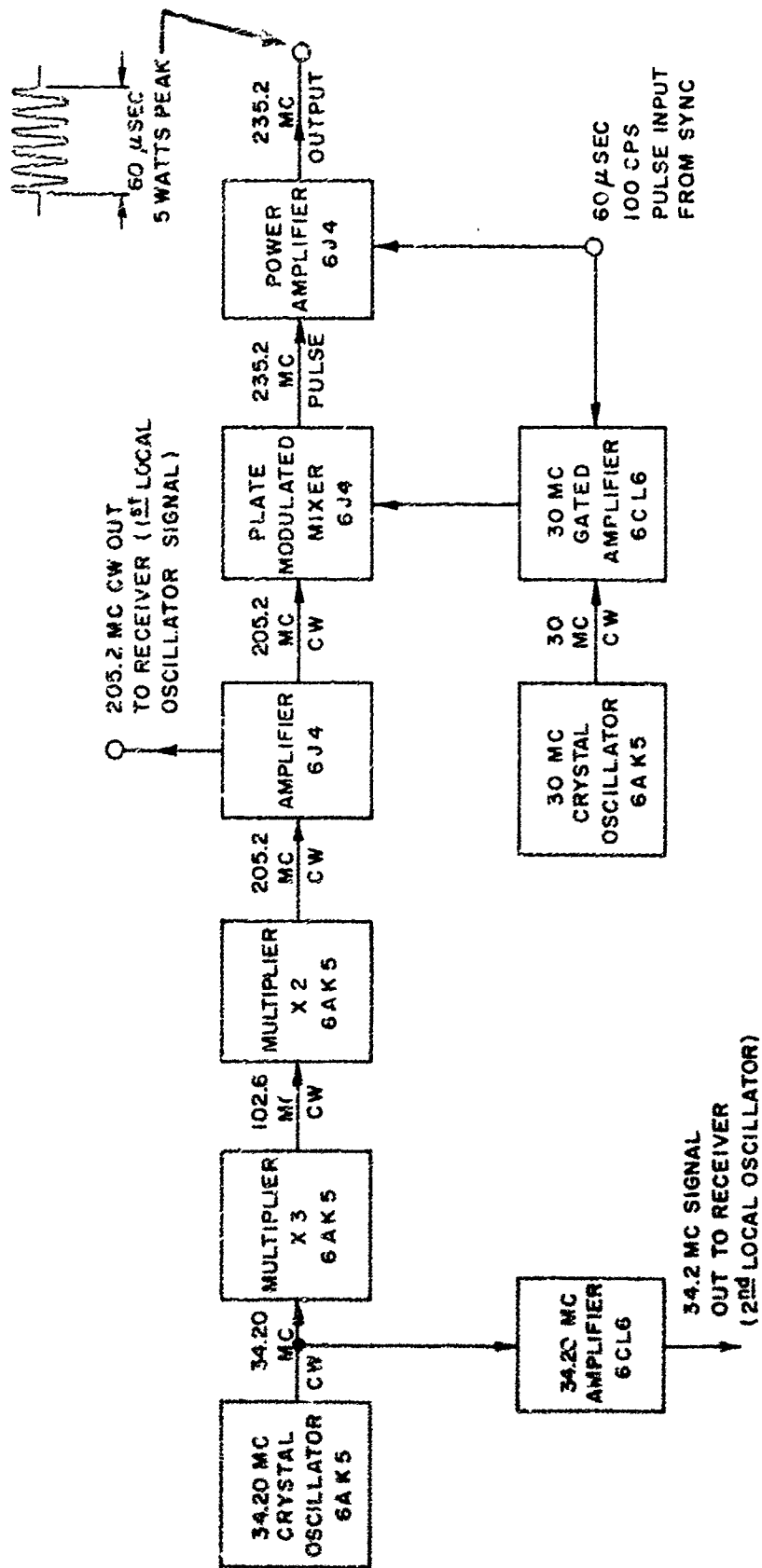

SECRET

FIGURE 3. EXCITER UNIT

SECRET

the driver amplifiers, the 60⁰ R.F. amplifier, and the 30-megacycle gate amplifier in the exciter. Work on this unit will be started when the evaluation of the suitability of the 4X250B has been completed.

Power Supplies

Plate, screen, and bias supplies for the units mentioned above are not being designed until a realistic estimate can be made of the power needed. At present, commercial laboratory supplies are being used.

3.2.1.2 High Power Work

Work to date has consisted of circuit design on the units comprising the high level portion of the transmitter, and procurement of component parts of these units. Circuit design work is about 70% complete (overall) and construction will follow as the components arrive. The work to date can be divided into six parts as follows:

1. Modulators - The prototype design is complete. The two units will be line-type modulators using a hydrogen thyratron and will allow plate pulsing of the A2515 up to 60,000 volts. All major items for the modulators were sent out for bids after the design was complete and have been ordered. These include the following: pulse transformers, charging reactors, storage capacitors, thyratrons, filament and reservoir transformers, Variacs, and material for the storage inductance. The two units will each be capable of supplying two megawatts peak power to the plates of each of the two A2515 final power amplifiers.
2. High Voltage Supplies - These supplies are being purchased to save money and engineering time. The design specifications were prepared and bids requested from three suppliers. F-R Machine Works, Inc. was chosen on the basis of price and delivery time and an order was placed for two units. Each supply will be capable of furnishing ten kilowatts D.C. (10,000 volts at one ampere) to each of the modulators. Delivery of the units is promised for the latter part of January, 1956.
3. Low Voltage Supplies - Design work is complete on the screen supply, bias supply, and filament supply for the A2515's. All components have been ordered. Layout is complete on the screen supply.

SECRET

4. Water System - Design of the system is complete and layout is in progress. Some components have been ordered such as flow meters, pressure switches, and connectors. A closed system will be used, with the heat being dissipated in a water-to-air heat exchanger.
5. R.F. Circuiting - Design of grid and plate cavities for cold cavity tests on the A2515 cavities is complete and some material has been ordered. It is expected that empirical work on the cavities will continue well into the spring. Requirements on an r.f. calorimeter and two water loads have been determined and the equipment will be ordered shortly.
6. The overall control-system design (incorporating safety precautions for equipment and personnel) is complete, and the major items such as relays, time delays, and meters have been ordered.

3.2.1.3 Work For Next Reporting Period

Exciter Driver Chain

1. Exciter Unit - A laboratory model will be constructed and tested during this period, and integrated into the master signal source.
2. Synchronizer - The parameters of the synchronizer will be verified in the laboratory. A laboratory model will be constructed, tested, and will be added to the master signal source.
3. Driver - Design of the r.f. amplifiers will be completed in this period. Material will be ordered and a breadboard will be started. The evaluation of the 4X250B will be completed.
4. Driver Modulator - Design of the hard-tube modulator will be completed in this period. A breadboard will be built and integration with the driver unit will be started.
5. Power Supplies and Rack - Interwiring, control, and rack mounting of some of the completed units will be made. A better estimate of power supply needs will be forthcoming in this period and design of such will be started.

SECRET

SECRET

High Power Work

It is expected that during this period the remaining portion of the design work on the transmitter units will be finished excepting the cavities. The layout of the modulators, final amplifiers, cabinets, control systems, and output plumbing should be finished and construction of these units well under way. The testing phase will not begin during this time because several components, notably the pulse transformer, will not be delivered until approximately April 15. The individual units including portions of the modulator will be tested as they are completed.

3.2.2 SUB-TASK TWO - EXPERIMENTAL ANTENNAS

This Sub-Task covers the design of a small array of about six dipole elements to be used in investigating phase stability and phase-pulling questions in conjunction with the initial power amplifier experiments discussed in Sub-Task One. It also covers the initiation of design of two full size experimental antenna arrays which will be used with the experimental transmitter and receiver in field and range tests. These antennas, operated with the simplified transmitter and one receiver will produce fixed beams only. Properly oriented, however, they can be used to obtain the missile cross section, and the meteoric and ionospheric data required. Work on this Sub-Task is awaiting initial results of the dipole radiator investigation being carried on under Sub-Task Four. When a satisfactory dipole design is achieved, design work will begin on the small experimental array to be used in conjunction with the transmitter phase stability experiments.

3.2.3 SUB-TASK THREE - RECEIVER AND INDICATOR

This Sub-Task covers the initiation of design of experimental receiver-indicator equipment which will be used in conjunction with the experimental transmitter and antenna arrays in obtaining data on meteoric and ionospheric returns, and in missile detection tests on a range. All elements of the receiving array will be fed in phase to the single receiver producing a single fixed beam perpendicular to the array. The indicator will be a standard oscillograph modified, if necessary, to display and enable the recording of received signals.

In the preliminary design of a single channel experimental receiver for the PLATO System Acquisition Radar, the following are being used as first objectives:

1. Center frequency - 235 megacycles
2. Overall bandwidth - approximately 20 kilocycles
3. Sensitivity - sufficient to generate one volt of noise in the output
4. Noise figure - 4 db maximum

SECRET

These requirements are in part determined by the general requirements of the PLATO System as presently designated. The block diagram below indicates the method that has been chosen to meet the design objectives.

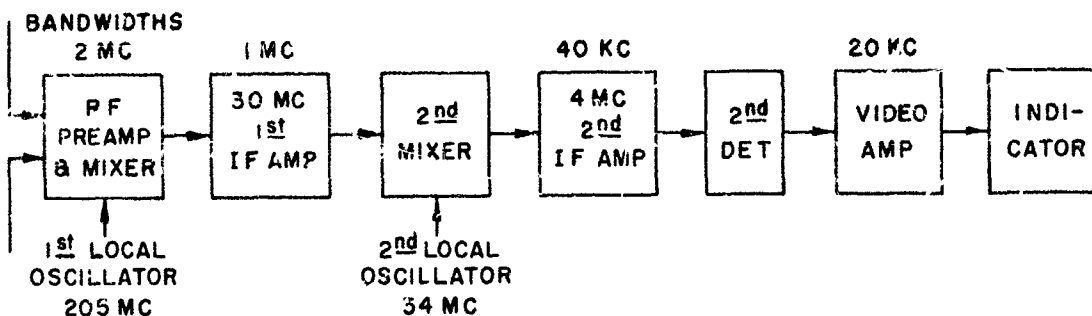

FIGURE 4. SINGLE CHANNEL EXPERIMENTAL RECEIVER

3.2.3.1 Receiver

The Preamplifier and Mixer

A block diagram of this unit is shown in Figure 5. It consists of two stages of r.f. amplification and a mixer.

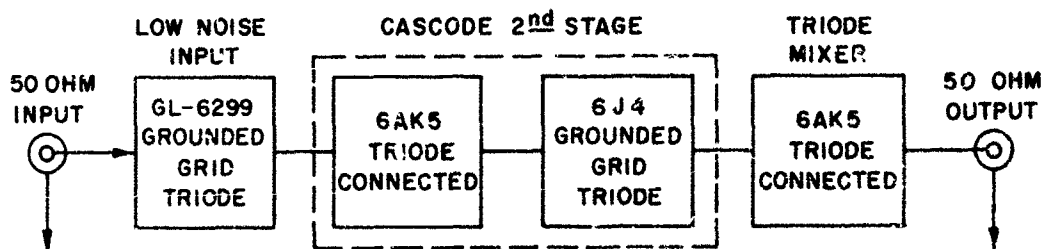

FIGURE 5. RF PREAMPLIFIER AND MIXER

The General Electric type GL-6299 coplanar triode was chosen as the first stage because of its low noise characteristics and high value of plate transconductance as well as the relative simplicity of mechanical and electrical design involved in its use. The second stage is a cascode circuit consisting of a triode-connected, grounded-cathode 6AK5 driving a 6J4 grounded-grid section. This stage was found to be a desirable addition

SECRET

because mixers inherently have high noise figures and calculations showed that the additional r.f. stage reduced the effect of the mixer on the overall noise figure by approximately one db.

The mixer stage is also a triode-connected, grounded-cathode 6AK5, operating with grid leak bias, and with the output tuned to 30 megacycles and tapped down to provide a 50 ohm output impedance.

An initial unit of the preamplifier has been designed and constructed and the following characteristics measured and recorded:

1. Center frequency - 235 megacycles
2. Bandwidth - 2 megacycles to the 3 db down points
3. Voltage gain - (from input to grid of first i.f. stage) 38 db
4. Image rejection - approximately 25 db.

Additional tests to be made on this unit will include measurement of noise figure, input and output impedances and spurious responses.

The First I.F. Amplifier and Second Mixer

This unit will consist of two or three stages in a conventional design using 6AK5's with synchronous-single-tuned interstages. 30 megacycles was chosen as the nominal center frequency of this amplifier as a reasonable compromise between good image rejection and simplicity of design.

The Second I.F. Amplifier

The center frequency of this unit will be in the range of three to five megacycles. This range has been chosen because:

1. It will provide at least 40 db image rejection within the passband of the high i.f. amplifier.
2. It will allow the design, for the required bandwidth of approximately 40 kilocycles, to be accomplished with conventional circuitry without recourse to special techniques, such as crystal filters.

The Second Detector and Video Amplifier

The second detector will be of conventional design using a germanium diode followed by a low-pass circuit having a cutoff frequency of approximately 20 kilocycles. Should a video amplifier be found necessary, it

SECRET

will be so designed as to provide a flatter response and sharper cutoff at 20 kilocycles.

3.2.3.2 Indicator

It is deemed neither desirable nor necessary to expend part of our present effort on the design of an indicator because the type of data which we desire to obtain with the experimental receiver can be observed using a laboratory oscilloscope.

3.2.3.3 Equipment For The Measurement Of Phase Stability

The equipment necessary to measure phase variations between the two pulsed amplifiers being designed under Sub-Task One employs receiver techniques and is therefore being carried and reported under this Sub-Task. To obtain the desired phase stability data, it is necessary to design and construct a piece of test equipment which is capable of measuring or indicating the quantities involved to a high degree of accuracy.

It is proposed that the sampled carrier frequency pulses be heterodyned with a local oscillator signal and the phase measurements made on the resulting 30-megacycle signal. Since heterodyning has no effect on phase, this is both a feasible and desirable method of accomplishing the desired measurements.

The design consists of two identical broadband (for a 60-microsecond pulse) amplifiers feeding separate grids of a 6BN6 gated beam amplifier, as shown in Figure 6 below. The amplifiers will be linear to the grids of the 6BN6. The 6AN5 final stages will be capable of delivering about 20 volts r.m.s., which will be more than sufficient to saturate the 6BN6. This will insure the greatest degree of amplitude independence. The width of the 30-megacycle current pulses at the plate of the 6BN6 will be directly related to the phase angle between the two incoming signals.

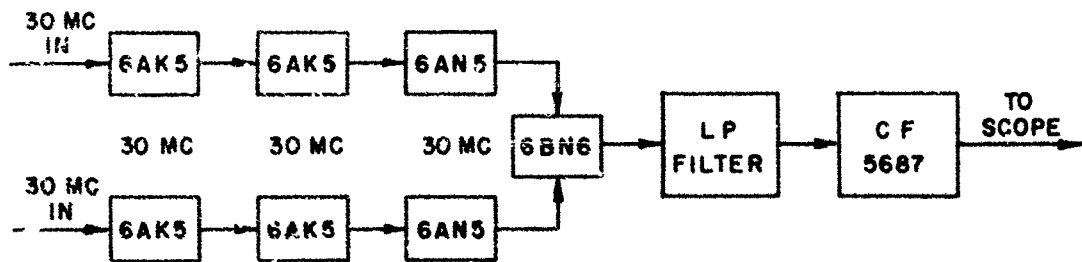

FIGURE 6. 30-MEGACYCLE PHASE DETECTOR

SECRET

The 6BN6 will be followed by a low pass filter, the output of which will be essentially a d.c. signal whose amplitude is proportional to the phase angle difference. The final stage will be a 5687 double triode used as a cathode follower with the two sections connected in parallel. This tube was chosen for its high transconductance and the wide range of linear operation in its dynamic characteristics.

It is expected that the phase detector will provide an output of about 12 volts peak-to-peak for a phase angle variation of from zero to 180 degrees. A laboratory oscilloscope will be used as the indicating instrument.

The circuit and chassis layout designs have been completed and chassis construction begun.

3.2.3.4 Work For Next Reporting Period

Single Channel Receiver

Evaluation of the unit already constructed will be continued. Measurements of noise figure, input and output impedances, and spurious responses will be made and if necessary, the design will be modified to meet the requirements. The design of the 30-megacycle i.f. amplifier will be undertaken.

Phase Measurement

The construction of the 30-megacycle phase detector will be completed and the unit will be calibrated and evaluated.

3.2.4 SUB-TASK FOUR - ANTENNA RESEARCH

This Sub-Task covers the initiation of detailed electrical design of antennas with the required electrical characteristics for use with the experimental acquisition radar transmitter and receiver. Initial emphasis is being placed on an investigation of various radiating elements, both linearly and circularly polarized types, to determine which will suit the requirements of the acquisition radar most satisfactorily. Emphasis is being placed on determining the capabilities and limitations of various elements from the point of view of bandwidth, power handling capability, input impedance and its variation over the band, difficulty of converting from unbalanced feed line to the balanced radiating element, radiation pattern, ease of construction, and de-icing and influence on inter-element mutual coupling. A survey of the literature is continuing to obtain additional data.

SECRET

The goals which at present seem desirable for the antenna elements are:

Frequency range: $\pm 10\%$ in the range 200-300 megacycles.

Standing wave ratio: 1.1 or less over the $\pm 10\%$ band.

Element beam width: 80° in both the horizontal plane for the vertical array and the vertical plane for the horizontal array.

Power handling capability: 1 megawatt peak power, 6 kilowatt average power.

Types of elements under investigation are:

Linearly Polarized elements:

- Loop
- Dipole
- Folded dipole
- Sleeve dipole

Circularly Polarized Elements:

- Crossed dipole
- Crossed sleeve dipole
- Crossed loop
- Helix

Scale model measurements are now being performed on promising element and balun designs using a frequency in "L" band to obtain some experimental verification of initial element designs. A slotted line is necessary to make precise measurements of full size element input impedance. Approval has been received for the purchase of a Federal Model FTL-30A slotted line and this unit is now on order.

During the next reporting period the investigation and measurements program will continue. The objective is to achieve, by scale and full size model measurements and by a thorough theoretical investigation, optimum designs for both circularly polarized and linearly polarized elements.

3.2.5 SUB-TASK FIVE - ELECTRO-MECHANICAL SCANNER FOR TRANSMITTER ANTENNA

This Sub-Task provides for the initiation of design of phase shifting and power dividing devices suitable for application later to the experimental transmitter. Since the low level power division requirement is a relatively simple one to meet, a majority of the effort under this Sub-Task

SECRET

is to be applied to the phase shifter with initial attention directed towards the design of low level devices in consonance with the choice of transmitter configurations first investigated under Sub-Task One. A survey of possible applicable phase shifting devices is now underway to be followed by the start of design work on experimental models.

3.2.6 SUB-TASK SIX - RECEIVER PHASING MATRIX

This Sub-Task provides for the initiation of an investigation of those receiving beam-forming network critical components which are intended to produce the multi-beam vertical coverage pattern described in the Acquisition Radar Technical Report and in the PLATO Phase I and II Reports. It also provides for a continuing evaluation of the PANAR techniques developed by Sanders Associates primarily for airborne applications under W.A.D.C. contract AF33(600)27586. This evaluation is underway with the intent of assessing the applicability of this technique to the acquisition radar receiving system.

CONFIDENTIAL

APPENDIX I

BIOGRAPHICAL SKETCHES OF NEW TECHNICAL PERSONNEL

MILTON D. RUBIN - *Manager Of The Analysis Department*

Mr. Rubin received his BS in EE at Harvard in 1935. He has taken numerous graduate courses in electrical engineering at the same institution. For four years (1940-1944), he served as an electrical engineer at the Boston Naval Shipyard where he worked on power, communications, and magnetic mine detection. From 1944 to 1948 he was employed by the Raytheon Manufacturing Company, Waltham, Mass., as a project engineer on Radar and Beacon work. He was Research Director of Analog Computers for G. A. Philbrick Researchers, Inc., Boston, from 1948 to 1949. From 1949 to 1951 he served with the Laboratory for Electronics, Inc., Boston, as a project engineer in radar and computer design. He was a Group Leader at the Lincoln Laboratory at MIT from 1951 to 1955. Mr. Rubin recently joined Sylvania's Missile Systems Laboratory as Manager of the Analysis Department.

ROY SPENCER - *Senior Engineering Specialist and Consultant*

Dr. Spencer received a BA in Physics and Mathematics at Cornell University in 1922. He received his Ph. D. in Physics from Columbia University in 1932. He was employed by Swarthmore College as a Fellow in Astronomy from 1922 to 1923. From 1923 to 1925 he was at Cornell University working as a research assistant in X-rays and later as a Fellow in Physics. He was an instructor in Physics at Columbia University from 1927 to 1931 and from 1931 to 1941 was an instructor in Physics at the University of Nebraska. From 1941 to 1946 he was employed by the Radiation Laboratory at MIT where he collaborated on research and radar, mostly on antenna and diffraction problems. From 1946 to 1955 he was engaged in antenna research at the Antenna Laboratory of the Air Force Cambridge Research Center. In 1955, Dr. Spencer joined the Sylvania Missile System Laboratory as a Senior Engineering Specialist and Consultant.

IRVING B. GOLDBERG - *Senior Engineer*

Mr. Goldberg received a BA in Mathematics and Physics at Boston University in 1950. In 1951 he attended the Boston University Graduate School, studying advanced topics in mathematics and physics. From 1951 to 1955 he was employed by Tracelab Inc., as a Group Leader in nucleonic research. He there was engaged in low-level beta counting systems, gas counting systems, ionization chambers, radio-activity detection techniques, mathematical-physical analysis, and counting statistics. In June, 1955 Mr. Goldberg joined Sylvania's Missile Systems Laboratory where he is a Senior Engineer in the Radar Section of the Electronics Department.

CONFIDENTIAL

ALBERT RAND - Senior Engineer

Mr. Rand received a BS in ME at MIT in 1950 and a MS in ME in 1954. From 1950 to 1952 he was engaged in chemical process dynamic analysis at E. I. DuPont. From 1952 to 1954, he was a research mechanical engineer at the MIT Servo Laboratory where he was engaged in the design of AC torque motors for hydraulic amplifiers. From 1954 to 1955, he was employed by N. Y. Air Brake as a project engineer working on the design of hydraulic servomechanisms. In November 1955, Mr. Rand joined Sylvania's Missile Systems Laboratory as a Senior Engineer in the Missile Department.

EDWARD B. TEMPLE - Senior Engineer

Mr. Temple received his AB degree in languages from Lafayette College in 1942 and received his MS degree in applied mathematics from Brown University in 1943. In 1950 he did graduate work in meteorology at MIT. He was an instructor in the mathematics department at William and Mary College during the years 1943 to 1944 and also during 1946 - 1947. He was a mathematics instructor at MIT from 1948 to 1951. From 1951 to 1955, he was Research Mathematician at the Naval Supersonics Laboratory at MIT. Here he was engaged in research work in the field of physical optics, Schlieren optics and also did IBM computational research. Mr. Temple recently joined Sylvania's Missile Systems Laboratory as a Senior Engineer in the Analysis Department.

DAVID J. FARRELL - Engineer

Mr. Farrell received a BS in mathematics from Boston College in 1955. Upon graduation, he joined Sylvania's Missile Systems Laboratory as an Engineer in the Analysis Department.

BETTIE ANNE FRANCIS - Engineer

Miss Francis received a BS in EE from the University of Massachusetts in 1953 and is currently studying for a graduate degree at Northeastern University. In 1953 she served as a technical assistant at MIT. Miss Francis joined Sylvania's Avionics Laboratories as an Engineer. She has worked on microwaves, spectrum analysis, crystal evaluation and ferites. She is currently working in the Analysis Department in the Missile Systems Laboratory.

JOHN GIOVANNUCCI - Engineer

Mr. Giovannucci received his BA degree in physics and mathematics at Rutgers University in 1951. In 1951 he was employed as a junior engineer for the Selly Manufacturing Company, Brooklyn, New York. Here he worked on the development of a centrifugal casting machine for shell moulds. From 1951 to 1953 he was employed by the American Power Jet Company as a

CONFIDENTIAL

MARC A. ABELL - Engineer

Mr. Abell received a BS in Mathematics at Michigan State University in 1953. From 1951 to 1955 he served in the U.S. Air Force as a senior radar technician and became an instructor in the radar school. He recently joined Sylvania's Missile Systems Laboratory as an Engineer in the Electronic Development Department.

CONFIDENTIAL

APPENDIX II
CONFERENCES

VISITS BY PERSONNEL OF THE MISSILE SYSTEMS LABORATORY

TO: Project Lincoln
DATE: October 13, 1955
VISITED: H. Weiss and E. L. Key
BY: M. Lowe, C. Jacobs, and S. Falconer
SUMMARY: Discussed the possible PLATO Acquisition Radar application of pulsed klystron which Eimac has built for Lincoln.

TO: White Sands Proving Ground, New Mexico
DATE: November 7, 8, and 9, 1955
VISITED: Personnel of the White Sands Proving Ground
BY: D. J. Crowley and C. E. Jacobs
SUMMARY: The purpose of this visit was (1) to discuss the possibility of obtaining radar tracking data from WSPG missile firings, and (2) to obtain information on the MIRAN system of range triangulation.

TO: Fort Monmouth, N.J.
DATE: November 17 and 18, 1955
VISITED: 4th Hydrogen Thyatron Symposium
BY: M. E. Lowe
SUMMARY: Technical information was exchanged between tube engineers and equipment manufacturers who are concerned with circuitry for tubes.

TO: International Business Machines Corp., N.Y.
DATE: December 8, 1955
VISITED: IBM Engineering Department Heads
BY: H. C. Harris
SUMMARY: Discussed the PLATO Computers.

TO: MIF Lincoln Laboratory
DATE: December 21, 1955
VISITED: Laboratory personnel
BY: H. C. Harris, N. Wolfsohn, and C. Jacobs
SUMMARY: Discussed various aspects of the prediction problem.

CONFIDENTIAL