

UNCLASSIFIED

AD NUMBER

AD371681

CLASSIFICATION CHANGES

TO: UNCLASSIFIED

FROM: CONFIDENTIAL

LIMITATION CHANGES

TO:
Approved for public release; distribution is unlimited.

FROM:
Distribution authorized to U.S. Gov't. agencies and their contractors;
Administrative/Operational Use; MAR 1966. Other requests shall be referred to U.S. Army Aviation Materiel Laboratories Fort Eustis, Virginia 23604.

AUTHORITY

USAAMRDL ltr 8 Sep 1976; USAAMRDL ltr 8 Sep 1976

UNCLASSIFIED

AD

371 681

**CLASSIFICATION CHANGED
TO: UNCLASSIFIED
FROM: CONFIDENTIAL
AUTHORITY:**

— USAAMB DL Ltr, 8 SEP 76

UNCLASSIFIED

SECURITY

MARKING

The classified or limited status of this report applies to each page, unless otherwise marked.

Separate page printouts MUST be marked accordingly.

THIS DOCUMENT CONTAINS INFORMATION AFFECTING THE NATIONAL DEFENSE OF THE UNITED STATES WITHIN THE MEANING OF THE ESPIONAGE LAWS, TITLE 18, U.S.C., SECTIONS 793 AND 794. THE TRANSMISSION OR THE REVELATION OF ITS CONTENTS IN ANY MANNER TO AN UNAUTHORIZED PERSON IS PROHIBITED BY LAW.

NOTICE: When government or other drawings, specifications or other data are used for any purpose other than in connection with a definitely related government procurement operation, the U. S. Government thereby incurs no responsibility, nor any obligation whatsoever; and the fact that the Government may have formulated, furnished, or in any way supplied the said drawings, specifications, or other data is not to be regarded by implication or otherwise as in any manner licensing the holder or any other person or corporation, or conveying any rights or permission to manufacture, use or sell any patented invention that may in any way be related thereto.

CMF - R - 13854
CONFIDENTIAL

AD



371681

USAAVLABS TECHNICAL REPORT 66-7

**TECHNICAL FEASIBILITY STUDY AND
PRELIMINARY DESIGN STUDY,
AIRMOBILE ARTILLERY (U)**

VOLUME II

By

Ernest Stuckal

March 1966

U. S. ARMY AVIATION MATERIEL LABORATORIES

FORT EUSTIS, VIRGINIA

CONTRACT DA 44-177-AMC-132(T)

UNITED AIRCRAFT CORPORATION

SIKORSKY AIRCRAFT DIVISION

STRATFORD, CONNECTICUT

D D C
RECEIVED
MAY 2 1966
RECEIVED
A

In addition to security requirements which apply to this document and must be met, each transmittal outside the agencies of the US Government must have prior approval of US Army Aviation Materiel Laboratories, Fort Eustis, Virginia 23604

Downgraded at 12 year intervals; not automatically declassified. DOD DIR 5200.10



"This document contains information affecting the national defense of the United States, within the meaning of The Espionage Laws, Title 18, U.S.C., Sections 793 and 794, the transmission or revelation of which in any manner to an unauthorized person is prohibited by law."

CONFIDENTIAL

Copy of 69 Copies

Disclaimers

The findings in this report are not to be construed as an official Department of the Army position unless so designated by other authorized documents.

When Government drawings, specifications, or other data are used for any purpose other than in connection with a definitely related Government procurement operation, the United States Government thereby incurs no responsibility nor any obligation whatsoever; and the fact that the Government may have formulated, furnished, or in any way supplied the said drawings, specifications, or other data is not to be regarded by implication or otherwise as in any manner licensing the holder or any other person or corporation, or conveying any rights or permission, to manufacture, use, or sell any patented invention that may in any way be related thereto.

Trade names cited in this report do not constitute an official endorsement or approval of the use of such commercial hardware or software.

Disposition Instructions

When this report is no longer needed, Department of the Army organizations will destroy it in accordance with the procedures given in AR 380-5. Navy and Air Force elements will destroy it in accordance with applicable directions. Department of Defense contractors will destroy the report according to the requirement of Section 14 of the Industrial Security Manual for Safeguarding Classified Information. All others will return the report to US Army Aviation Materiel Laboratories, Fort Eustis, Virginia 23604.

CONFIDENTIAL

Task 1X120301DO3511
Contract DA 44-177-AMC-132(T)
USAAVLABS Technical Report 66-7
March 1966

TECHNICAL FEASIBILITY STUDY AND
PRELIMINARY DESIGN STUDY,
AIRMOBILE ARTILLERY (U)
VOLUME II

SER-50399

by

Ernest Stuckal

Prepared by

UNITED AIRCRAFT CORPORATION
SIKORSKY AIRCRAFT DIVISION
Stratford, Connecticut

for

U. S. ARMY AVIATION MATERIEL LABORATORIES
FORT EUSTIS, VIRGINIA

DOWNGRADED AT 12 YEAR
INTERVALS; NOT AUTOMATICALLY
DECLASSIFIED. DOD DIR 5200.10

"This document contains information affecting the national defense of the United States, within the meaning of The Espionage Laws, Title 18, U. S. C., Sections 793 and 794, the transmission or revelation of which in any manner to an unauthorized person is prohibited by law."

In addition to security requirements which apply to this document and must be met in transmission outside the agencies of the U. S. Government, it has prior approval of U. S. Army Aviation Materiel Laboratories, Fort Eustis, Virginia 23044.

CONFIDENTIAL

(U) CONTENTS

	Page
LIST OF ILLUSTRATIONS	v
LIST OF TABLES	vii
LIST OF SYMBOLS	ix
APPENDICES	
I. Mobile Artillery Weapon System Terminology.	225
II. Structural Factor.	227
III. Weight and Balance - Phase I (1964 - 1970)	229
IV. Equivalent Parasite Drag Estimate.	237
V. Lateral C. G. Evaluation.	239
VI. Structural Analysis - Phase I	241
VII. Description of Navigation Equipment.	368
VIII. Phase I, Firing Error Analysis	370
IX. Phase I, Navigation and Fire Control Subsystem	375
X. Time Required to Displace VTOL Airmobile Artillery Phase II, 1970 - 1980.	376
XI. Cost Comparison - VTOL Aircraft, Phase II, 1970 - 1980.	378
XII. Weight and Balance - Phase II (1970 - 1980).	383
XIII. Phase II, Structural Analysis	392
XIV. Phase II, Navigation and Fire Control Subsystem.	397
XV. Phase II, Firing Error Analysis.	398

(U) ILLUSTRATIONS

Figure		Page
53	YCH-54A B.L. C.G. vs. b_{1g} and ϕ in Hover	240
54	Zone 3 Frame Arrangement	242
55	Frame 154.5, Applied Loads Due to a Unit Uniform Pressure	246
56	Applied Loads to Frame 453.5 due to a Unit Uniform Pressure	261
57	Input and Response of Aircraft Structure to Shock Wave.	274
58	Loading due to Unit Pressure, Typical Frames 154.5, 191.5, 229, 453.5, 510	290
59	Partial Frame Station 219 and 238.5	300
60	Fuselage Longeron Reinforcement.	313
61	Electronic Gear and Gun Crew Pod	319
62	Electronic Gear and Gun Crew Pod	320
63	Equilibrium of Electronic Gear and Gun Crew Pod for Ultimate Load of 125 lb./ft. ²	321
64	Gun Crew Pod Frame Bending Analysis	322
65	Electronic Gear and Gun Crew Pod Typical Frame . . .	324
66	Gun Crew Pod Beam	325
67	Gun Crew Pod Typical Fitting.	328
68	Ammunition Pod for 105-mm. Howitzer	330
69	Ammunition Pod for 105-mm. Howitzer	331
70	Equilibrium of Ammunition Pod for 105-mm. Howitzer.	332

(U) ILLUSTRATIONS (Cont)

Figure		Page
71	Ammunition Pod - Internal Frame Applied Loads . . .	333
72	Ammunition Pod - External Frame Applied Loads . . .	333
73	Ammunition Pod - Internal Frame Analysis	334
74	Ammunition Pod - Internal Frame Bending Moments	335
75	Ammunition Pod - External Frame Analysis	336
76	Ammunition Pod - External Frame Bending Moments.	337
77	105-mm. Howitzer Ammunition Pod, Typical Frame	338
78	Ammunition Pod - Typical Fitting	341
79	XM102 - 105-mm. Howitzer Firing Platform.	344
80	318-mm. Rocket - Firing Platform	350
81	318-mm. Rocket - Firing Platform. Limit Overpressures	351
82	YCH-54A Overhead Monorail, 318-mm. Rocket	355
83	S-61A Rocket Pod Support Structure	359
84	Rocket Pod Support - Flight Loads	360
85	Rocket Pod Support - Firing at 70° Elevation	361
86	S-61A Rocket Pod - Ring Loads	365
87	Geometry of Firing Analysis	370
88	Doppler Navigation Error	372
89	Subsystem Firing Errors vs. Weapon Firing Error . .	374

(U) ILLUSTRATIONS (Cont)

Figure		Page
71	Ammunition Pod - Internal Frame Applied Loads . . .	333
72	Ammunition Pod - External Frame Applied Loads . . .	333
73	Ammunition Pod - Internal Frame Analysis	334
74	Ammunition Pod - Internal Frame Bending Moments.	335
75	Ammunition Pod - External Frame Analysis	336
76	Ammunition Pod - External Frame Bending Moments.	337
77	105-mm. Howitzer Ammunition Pod, Typical Frame	338
78	Ammunition Pod - Typical Fitting	341
79	XM102 - 105-mm. Howitzer Firing Platform.	344
80	318-mm. Rocket - Firing Platform	350
81	318-mm. Rocket - Firing Platform Limit Over- pressures.	351
82	YCH-54A Overhead Monorail, 318-mm. Rocket	355
83	S-61A Rocket Pod Support Structure	359
84	Rocket Pod Support - Flight Loads	360
85	Rocket Pod Support - Firing at 70° Elevation	361
86	S-61A Rocket Pod - Ring Loads	365
87	Geometry of Firing Analysis	370
88	Doppler Navigation Error	372
89	Subsystem Firing Errors vs. Weapon Firing Error . .	374

(U) TABLES

Table		Page
23	Structural Factor	227
24	Weight Empty Modifications - YCH-54A Airmobile Artillery.	231
25	Group Weight Recoding and Derivation - YCH-54A Airmobile Artillery.	232
26	Mission Weights - YCH-54A Airmobile Artillery.	233
27	Weight Empty Modifications - CH-3B (S-61A) Airmobile Artillery	234
28	Group Weight Derivation - CH-3B (S-61A) - Airmobile Artillery	235
29	Mission Weight - CH-3B (S-61A) Airmobile Artillery.	236
30	Equivalent Flat Plate Area "f"	237
31	Ultimate Capability of YCH-54A Fuselage	241
32	Frame 154.5 With Horizontal Axial Tie Shears, Bending Moments, and Axial Loads.	247
33	Frame 453.5 With Horizontal Axial Tie Shears, Bending Moments, and Axial Loads.	263
34	Blast Overpressures on YCH-54A due to 105-mm. Howitzer.	270
35	Typical Frame With Horizontal Axial Tie Shears, Bending Moments, and Axial Load.	291
36	S-61A Rocket Pod, Shears, Bending Moments, and Axial Loads.	364

(U) TABLES (Cont)

Table		Page
37	CPE Firing Error	373
38	Mission Time Requirements - Airmobile Artillery Aircraft	376
39	VTOL Aircraft Displacement Time	377
40	Procurement Costs	379
41	Estimated Maintenance Labor and Material Cost . . .	380
42	Estimated Operational Costs per Flight Hour.	381
43	Estimated Operational Cost per Mission	382
44	Group Weight Statement, Phase II Aircraft.	389
45	Mission Loadings - Primary Aircraft	390
46	Mission Loadings - Alternate Aircraft	391

(U) SYMBOLS

L. F.	Load Factor
Sta.	Station
W. L.	Water Line
B. L.	Buttock Line
c. g.	Center of Gravity
b_{is}	Main Rotor Flapping Angle
f	Equivalent Parasite Drag Area
%	Percent
psi	Pounds per Square Inch
fc	Comparison Stress, psi
fcu	Ultimate Allowable Compression Stress, psi
P	Internal Loads, lb. lb./inch
M	Bending Moment, in. -lb.
f_t	Tensile Stress, psi
f_{tu}	Ultimate Allowable Tensile Stress, psi
A	Area
b	Panel, width, inches
t	Thickness, inches
I	Moment of Inertia, in. ⁴
L	Length
E	Modulus of Elasticity, psi

(U) SYMBOLS (Cont)

π	Pi, 3. 1416
M. S.	Margin of Safety
q	Shear, lb. per inch
f_s	Shear, Stress, psi
v	Shear Load, lb.
ABR	Bearing Area
N2	Seat Pan Load, lb.
S	Shear, lb, Area
VCR	Cruise Velocity

(U) APPENDIX I

MOBILE ARTILLERY WEAPON SYSTEM TERMINOLOGY

The following terms are in use for mobile artillery weapon systems within the U. S. Army and are presented for general reference. Note that terms 3, 4, 5, and 6, air transportable artillery, airmobile artillery, aerial artillery, and air-propelled artillery have, in varying degrees, interchangeable meanings. Term 7 is a recommended term specifically applicable for this concept.

1. Self-Propelled Artillery

Conventional artillery mounted and fired from an integrated ground vehicle weapons platform for indirect fire support.

2. Aerial Weapons Aircraft

An aircraft weapons platform for small-arms direct suppressive and escort fire and a limited (small-arms) indirect fire capability (applicable to the advanced aerial fire support system - AAFSS).

3. Air Transportable Artillery

Conventional artillery of a physical size and weight that can be transported by aerial vehicles.

4. Airmobile Artillery

a. Conventional artillery transported by aerial vehicles (same as that used for air transportable artillery).

b. Traditional artillery and missile-type weapons mounted and fired from an integrated self-propelled air vehicle weapons platform for ground-to-ground indirect fire support (as used in this study).

5. Aerial Artillery

An integrated aerial weapons system to provide traditional artillery indirect ground-to-ground fire support for airmobile and air assault forces and direct air-to-ground fire support (implies partially the same meaning as airmobile artillery as used in this study).

6. Air-Propelled Artillery

A conventional artillery weapon mounted and fired from an integrated air vehicle weapons platform for indirect fire support (implies the same meaning as airmobile artillery as used in this study).

7. Airborne Artillery

An integrated aerial artillery weapon system to provide a traditional artillery indirect ground-to-ground fire support (a recommended term for describing this concept which specifies only the indirect fire support role but does not limit the weapon used to provide fire support).

(U) APPENDIX II

STRUCTURAL FACTOR

The "structural factor" is established as a parametric method of indicating an aircraft's inherent structural capability. The "structural factor" is limit load factor multiplied by design gross weight. This numerical reference is used as a comparative tool without going into extensive analysis. The "structural factor" should not be applied for finite comparisons because of variations in structural configuration and load application.

The limit load factors and gross weights for Sikorsky Aircraft are based on in-house data. The data shown for the other aircraft are based on published information and on Sikorsky's estimates, and are subject to revision by the cognizant manufacturers. It is believed that these numbers are sufficiently accurate to indicate these aircraft's relative structural capability.

It should be noted that with the exception of the CH-53A, all of the limit load factors fall within a narrow range. The CH-53A is the newest helicopter and its limit load factor of (3.0) is probably indicative of future trends in helicopter design requirements.

TABLE 23 (U)

STRUCTURAL FACTOR

Aircraft	Limit Load Factor	Gross Weight (lb.)	Structural Factor (Limit LF x G. W.)
YCH-54A	2.50	38,000	90,000
CH-53A	3.0	34,000	102,000
CH-3B	2.25	17,700	39,900
HH-52A	2.38	7,900	18,800
CH-46A	2.5	18,700	46,800
CH-47A	2.23	27,900	62,000

TABLE 23 (U)

STRUCTURAL FACTOR (Cont.)

Aircraft	Limit Load Factor	Gross Weight (lb.)	Structural Factor (Limit LF x G. W.)
UH-1D	2.3	8,800	20,000
UH-2A	2.17	10,000	21,700

Note: (1) Gross weight is the estimated weight at which the load factors were developed originally. They do not represent current operational or potential gross weights.

(2) The limit load factor is the maximum anticipated load to be experienced by the helicopter.

(U) APPENDIX III

WEIGHT AND BALANCE - PHASE I (1964-1970)

INTRODUCTION

This section presents the weight and balance changes required to modify two existing Sikorsky Aircraft models to the airmobile artillery concept.

In general the weights of both aircraft have been based on existing hardware, design layouts and analysis, and the information contained in Reference 1.

The primary aircraft is the YCH-54A, as defined by Reference 31. The modified version of this aircraft is shown by Figure 5 and Figure 6. This aircraft has been recoded to the new MIL-STD-451 format and these coding changes are shown herein in tabular form along with a group weight derivation of the modified aircraft.

The alternate aircraft is the CH-3B (S-61A), as defined by Reference 37. The modified version of this aircraft is shown by Figure 7. The group weight derivation shown herein is based on the standard AN-9255 format used in the above Reference 37.

It should be noted that the primary and alternate aircraft are not directly comparable due to the use of different coding format.

ABSTRACT

Weight and Balance Summary - YCH-54A, Airmobile Artillery

<u>Item</u>	<u>Weight (lb)</u>	<u>Sta.</u>	<u>WL</u>	<u>*BL</u>
Weight Empty	19,176	346.3	202.2	+3.5
Gross Weight - XM102 Howitzer	33,637	334.8	171.8	+5.9
Gross Weight - 318-mm. Rockets	33,417	343.4	176.6	+4.9

*port side (+)

The recommended fore and aft center of gravity limits as shown in Reference 32 are as follows:

Fwd. - from sta. 318.4 at 17,500 lb. tapering linearly to sta. 328.0
at 38,000 lb.
Aft - sta. 357.0

The recommended lateral offsets based on flapping and roll angles at 38,000 lb. are as follows:

Port - BL 18.8
Starboard - BL 9.2

The YCH-54A airmobile artillery configurations require no loading control since the horizontal and lateral centroids remain within the above limits throughout the normal operating conditions.

Weight and Balance Summary - CH-3B (S-61A) Airmobile Artillery

<u>Item</u>	<u>Weight (lb)</u>	<u>Sta.</u>	<u>WL</u>	<u>*BL</u>
Weight Empty	9,849	268.6	173.7	-0.3
Gross Weight	15,380	264.3	155.4	-0.6

*port side (+)

The recommended fore and aft center of gravity limits at all weights for the CH-3B helicopter are as follows:

Fwd. - sta. 259.0
Aft. - sta. 276.0

The CH-3B airmobile artillery configuration requires no loading control since the horizontal C. G. remains within the above limits throughout the normal operating conditions. The symmetrical arrangement of the useful load results in a negligible lateral offset.

TABLE 24 (U)

WEIGHT EMPTY MODIFICATIONS - YCH-54A AIRMOBILE ARTILLERY

Group	Design Criterion or Assumption	Weight (lb.) MIL-STD-451
Rotor	Blade positioning is required to prevent excessive blade stresses caused by blast overpressures	+142
Body	1. Modify structure to withstand effects of blast overpressures 2. Remove aft pilot enclosure 3. Add transmission fairing (dog house)	+225 - 48 +120
Allighting Gear	Modify structure to withstand effects of blast overpressures	+ 31
Engine Section	Add engine cowling and fire wall	+168
Power Plant	1. Incorporation of transmission fairing requires moving of oil cooler and additional ducts and lines 2. Modify main gearbox due to HP increase	+ 15 +180
Instruments	1. Remove aft pilot instruments 2. Add fire control system indicators	- 6 + 36
Flight Controls	1. Remove aft pilot controls	- 17
Hydraulics	Incorporation of transmission fairing requires moving of reservoirs	0
Electronics	Remove aft pilot interphone from weight empty	- 6
Furnishings	1. Add fire extinguishing and detection system 2. Remove aft pilot seat and equipment	+ 65 - 24
Auxiliary Power Plant	Incorporation of transmission fairing requires exhaust extension and addition of fire wall	+ 12
Auxiliary Gear	Payload requirements permit removal of 10 existing hard points	- 40
	Total Weight Empty Changes	+853

TABLE 25 (U)
GROUP WEIGHT RECODING AND DERIVATION - YCH-54A
AIRMOBILE ARTILLERY

Item	SER-64059 AN-9255		Recoded MIL-STD-451		Airmobile Artillery
Rotor Group	4,555	-504	4,051	+142	4,193
Blades	2,115		2,115		2,115
Hinge & Hub Assembly	2,440	-504	1,936		1,936
Blade Positioning	-		-	+142	142
Tail Group	426	- 7	419	-	419
Stabilizer	56	+ 3	59		59
Tail Rotor	370	- 10	360		360
Body Group	3,198	-525	2,673	+297	2,970
Structure	3,056	-383	2,673	+297	2,970
Provisions for Equip.	142	-142	-		
Alighting Gear	1,786	+ 17	1,803	+ 31	1,834
Main Landing Gear	931	+ 25	956		956
Auxiliary Landing Gear	192	+ 5	197		197
Tail Skid	31		31		31
Main Landing Gear Suppts.	632	- 13	619	+ 31	650
Engine Section	86	- 27	59	+168	227
Power Plant Group	6,000	+351	6,351	+195	6,546
Engine(as installed)	1,750	+ 41	1,791		1,791
Engine Accessories	91	- 35	56		56
Power Plant Controls	26	+ 9	35		35
Rotor Drive	3,481	+317	3,798	+180	3,978
Transmission Drive	24	- 24	-		-
Starting System	93	- 13	80		80
Lube System	53		53	+ 15	68
Fuel System	482	+ 56	538		538
Fixed Equipment Group	2,166	+801	2,967	+ 20	2,987
Instruments	194	+ 80	274	+ 30	304
Flight Controls	430	+731	1,161	- 17	1,144
Hydraulic System	378	-210	168		168
Electrical	420	+ 22	442		442
Communicating	292	- 4	288	- 6	282
Furnishings	265	- 88	177	+ 41	218
Anti-Icing Equip.	26	- 6	20		20
Auxiliary Power Plant	161	+ 6	167	+ 12	179
Air Conditioning	-	+ 91	91		91
Auxiliary Gear	-	+179	179	- 40	139
Weight Empty	18,217	+106	18,323	+853	19,176
Oil - Reduction Gearbox	106		In Rotor Drive		In Rotor Drive

TABLE 26 (U)

MISSION WEIGHTS - YCH-54A AIRMOBILE ARTILLERY

Item	XM102 Howitzer	318-mm. Rockets
Weight Empty - YCH-54A, Airmobile Artillery	19,176	19,176
Useful Load	14,461	14,241
Pilot & Copilot	400	400
Gun Crew (5)	1,000	1,000
Fuel - Usable (626.5 gal) (624.6 gal) JP-4	4,072	4,060
- Unusable (2.5 gal) JP-4	16	16
Oil - Engine (1.9 gal)	14	14
- Unusable (0.8 gal)	6	6
Gun Crew Pod	(1,164)	(964)
Pod & Furnishings	335	335
Fire Control Equipment	200	100
Fire Control System	349	349
Misc. Tools & Equipment	280	180
Weapon Platform	(4,022)	(2,561)
Platform, including spading	1,630	1,430
Weapon	2,252	1,071
Fire Control Equipment	140	60
Ammunition & Storage	(3,305)	(4,820)
Ammunition	2,520	4,390
Storage	785	430
Miscellaneous	(462)	(400)
4-Point Winch System	380	380
Seat Cushions	5	5
Crew Pod Fairing	15	15
Canvas Covers	62	-
Gross Weight	33,637	33,417

TABLE 27 (U)

WEIGHT EMPTY MODIFICATIONS - CH-3B (S-61A)
AIRMOBILE ARTILLERY

Group	Design Criterion or Assumption	Weight AN-9255
Rotor	Add blade locating	+ 30
Body	1. Add LHS sliding door and tracks	+ 49
	2. Remove floor extensions	- 45
	3. Modify main gearbox supports	+ 2
Alighting Gear	Modify structure to accommodate rocket pods	+ 10
Power Plant	1. Replace T58-8 engines with T58-10	+ 92
	2. Replace existing main gearbox with the CH-3C main gearbox to accommodate increased HP and APP	+ 96
	3. Remove self-sealing feature on fuel cells	-288
Instruments	Add fire control system indicators	+ 36
Electrical	Remove extra battery	- 65
Electronics	1. Replace existing electronics with those used in the YCH-54A, AMA	+ 9
	2. Remove the Doppler antenna from the fire control system and add it to this system	+ 26
Armament	Add lines, plumbing, etc. for hydraulic control of rocket pods	+ 35
Furnishings	1. Add heater	+ 28
	2. Add personnel ladders for aft doors	+ 14
Anti-Icing	Add anti-icing	+ 20
Auxiliary Power Plant	Add CH-3C auxiliary power plant	+194
Total Weight Empty Changes		+243

TABLE 28 (U)

GROUP WEIGHT DERIVATION-CH -3B(S-61A) - AIRMOBILE ARTILLERY

Item	SE-1505 AN-9255		Airmobile Artillery
Rotor Group	2,033	+ 30	2,063
Blades	1,039		1,039
Hinge Assembly	816		816
Hub	170		170
Fairing	8		8
Blade Locating		+ 30	30
Tail Group	151	0	151
Stabilizer	30		30
Tail Rotor	121		121
Body Group	2,342	+ 6	2,348
Alighting Gear	391	+ 10	401
Engine Section	129	0	129
Power Plant Group	2,847	-100	2,747
Engine (as installed)	595	+ 92	687
Engine Accessories	19		19
Power Plant Controls	19		19
Rotor Drive	160	+ 5	165
Transmission Cooling	58		58
Transmission Drive	1,428	+ 91	1,519
Starting System	34		34
Lube System	31		31
Fuel System	503	-288	215
Fixed Equipment	1,713	+297	2,010
Instruments	172	+ 36	208
Flight Controls	459		459
Hydraulic System	42		42
Electrical	520	- 65	455
Communicating	273	+ 35	308
Armament Provisions		+ 35	35
Furnishings	237	+ 42	279
Anti-Icing Equipment	10	+ 20	30
Auxiliary Power Plant		+194	194
Weight Empty	9,606	+243	9,849

TABLE 29 (U)

MISSION WEIGHT - CH-3B (S-61A) AIRMOBILE ARTILLERY

Item	Weight
Weight Empty - CH-3B, Airmobile Artillery	9,849
Useful Load	5,531
Pilot & Copilot	(400)
Weapon Crew (5)	(1,000)
Fuel - Usable (195 gal) JP-4	(1,266)
- Unusable (3.0 gal) JP-4	(20)
Oil - Engine (4.3 gal)	(32)
- Unusable (0.7 gal)	(5)
- Transmission (12.7 gal)	(95)
Armament	(1,058)
YCH-54-AMA Fire Control System less Doppler Antenna and FADAC Computer	147
Fire Control Equipment	240
Rocket Pods (2)	450
Rocket Storage	221
Ammunition	(1,614)
4.5" Rockets - Pods (14)	602
- Stored (24)	1,012
Troop Seats	(30)
Seat & Back Cushions	(11)
Gross Weight - CH-3B Airmobile Artillery	15,380

(U) APPENDIX IV

EQUIVALENT PARASITE DRAG ESTIMATE

Estimates were made of the equivalent flat-plate (parasite drag) area "f" of the various aircraft configurations as shown in Table 30. The same estimates are used for both weapon installations on the Phase I YCH-54A system and the 60-ft. -diameter Phase II aircraft system because actual differences in drag between similar externally placed weapons cannot be established without some form of test program.

The estimates for Phase I aircraft are based on additions to known "f" for these existing aircraft. Estimates for the additions to the Phase I aircraft and for the Phase II aircraft systems are based on information presented in Reference 59, Fluid Dynamics Drag.

TABLE 30 (U)

EQUIVALENT FLAT-PLATE AREA "f"

Item	AIRCRAFT			
	Phase I		Phase II	
	YCH-54A	S-61A	Primary	Alternate
Fuselage	26.2	5.12	4.1	3.2
Main Rotor Pylon	6.2	2.36	1.4	1.4
Main Rotor Head	15.65	9.92	10.0	7.0
Tail Rotor Head	2.8	1.76	2.8	2.8
Main Landing Gear	13.1	8.00	8.0	8.8
Tail Landing Gear	----	.46	1.3	.5
Tail Rotor Drive-Shaft Cover	----	----	.3	.3
Vertical Tail Stabilizer	.6	.37	.6	.6
Horizontal Stabilizer	1.5	.25	1.2	1.2
Engine Nacelles	----	----	2.2	2.2
Rocket Pods	----	.16	----	----
Rocket Pod Supports	----	1.68	----	----
Windows	----	----	----	.2
Sponsons	----	----	----	2.06
Weapon Platform - (Left Side of Cabin)	17.5	----	6.0	----
Trail R. H. Side	----	----	1.0	----
Armament	----	----	15.8	7.20
Antenna	----	----	.4	.40
Nose Landing Gear	2.6	----	----	----

TABLE 30 (U)

EQUIVALENT FLAT-PLATE AREA "f" (Cont.)

Item	AIRCRAFT			
	Phase I		Phase II	
	YCH-54A	S-61A	Primary	Alternate
Tail Rotor Drive Shaft & Supports	2.0	----	----	----
Ammunition Pod	20.0	----	----	----
Gun Crew Pod	7.0	----	----	----
Protuberances	3.0	2.05	1.0	1.00
Momentum Losses	----	1.17	2.0	2.00
Misc. Leakage, etc., 5% Total A/C Drag	5.0	----	2.2	3.56
Total "f" = (sq. ft.)	109.	33.3	60.3	44.4

(U) APPENDIX V

LATERAL C. G. EVALUATION

An analysis of the YCH-54A's trim in hover was made to determine the effect of the unusual lateral c. g. caused by the outboard weapon installations. The analysis was made for two gross weight conditions representing average aircraft weight for extreme payload conditions.

A static study was made by summing the forces and moments in the lateral plane and thus determining b_{is} and ϕ as functions of lateral c. g. location and gross weight. The following conditions were assumed:

1. Neutral longitudinal c. g.
2. Sea Level Standard Day
3. Gross Weight: 27,000 pounds and 38,000 pounds
4. Vertical drag: 5%

The results of the study are shown in Figure 53 as a plot of b_{is} and ϕ versus c. g. location in hover. These results indicate the following:

1. The aircraft variation in lateral c. g. position from 3.5 in. to 5.9 in. (Reference Appendix III) is well within the allowable control limits of the aircraft, as shown in Figure 53.
2. The aircraft's flight position will vary in roll from approximately $.5^\circ$ to 1.25° .
3. A larger c. g. offset can be accepted on the left-hand side of the aircraft, where the weapon is installed, than on the right-hand side of the aircraft.
4. That large changes in aircraft weight for the c. g. locations developed in the weight and balance study of 3.5 in. to 5.9 in. result in small changes in aircraft roll (ϕ) and main rotor flapping (b_{is}) angles.

S.L. Standard Day
 Vertical Drag 5%
 Neutral Longitudinal C.G.

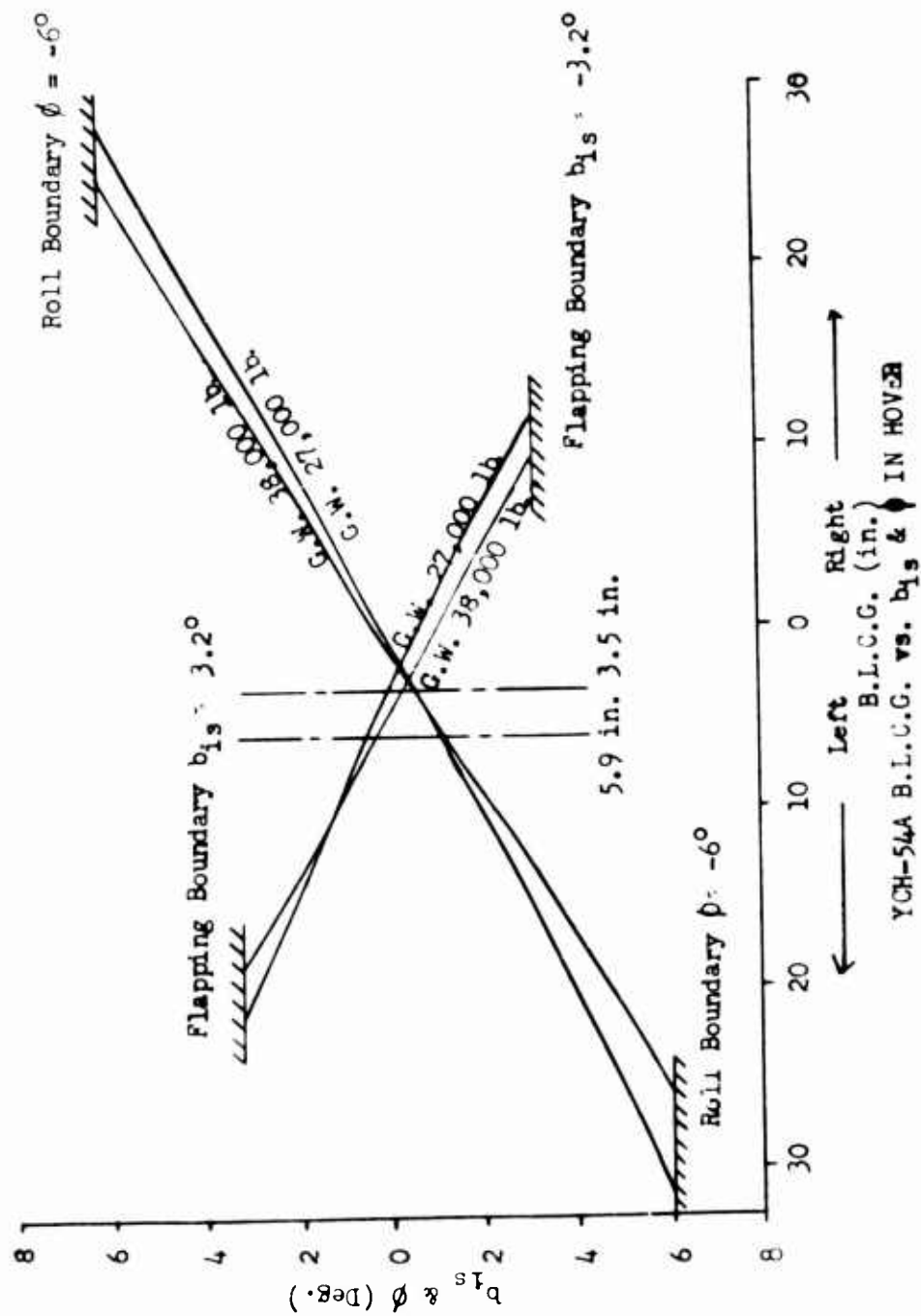

Figure 53. (U) YCH-54A B. L. C. G. vs. b_{1s} & ϕ in Hover

(U) APPENDIX VI

STRUCTURAL ANALYSIS - PHASE I

(U) STRUCTURAL EVALUATION, YCH-54A

In order to determine which zones would require structural modifications due to excessive blast overpressures, the ultimate capabilities of those zones closest to the muzzle were evaluated. The ultimate capabilities of the frames and stringers in these areas are listed in Table 31 below. The capabilities were determined by comparing the stresses resulting from a unit uniform pressure with the ultimate allowable stresses.

TABLE 31 (U)

ULTIMATE CAPABILITY OF YCH-54A FUSELAGE

Zone	STA	Frame PSI	Stringer PSI	Intercostal PSI
3	124	14.3	3.56	6.0
4	154.5	1.385	5.2	--
5	191.5	1.385	5.2	--
6	229.0	1.385	7.15	10.6
7	--	--	9.60	10.6
8/9	453.5	0.726	6.7	--
9	510.0	0.726	6.7	--
10	--	--	5.1	--
11/12	--	--	5.32	--

It should be noted that the skin capabilities have not been determined since the stresses in the skin are not directly proportional to the load. Therefore the skins must be analyzed for the actual pressures.

The analysis to determine the frame and stringer capabilities is as follows:

Evaluation of Frame and Stringer Capabilities

Zone 3 (Reference Figure 54):

The frame at station 124 is not continuous but is broken by intercostals which run from F. S. 112 to F. S. 136. The frame and intercostals are critical in the areas shown below.

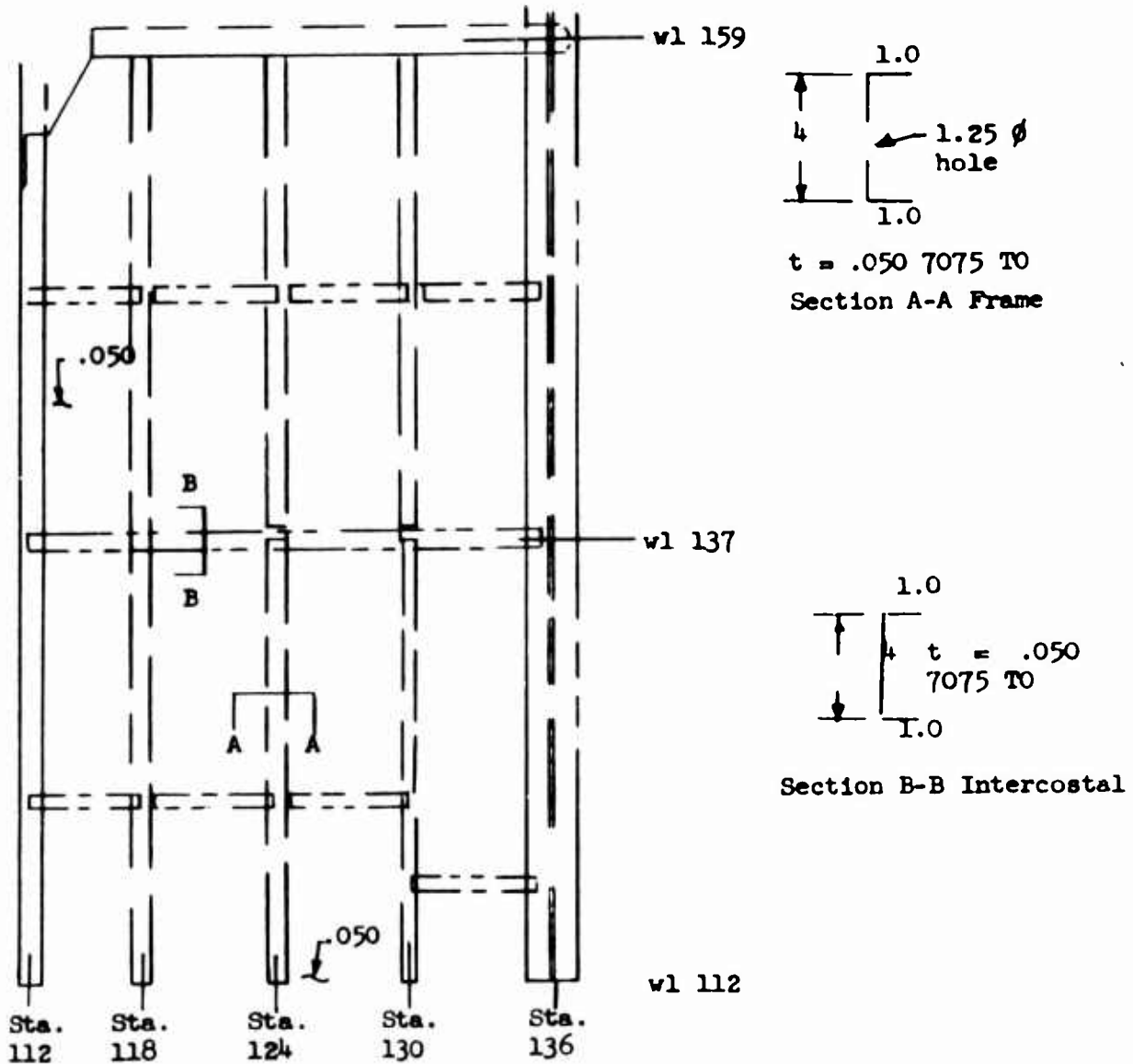

Figure 54. (U) Zone 3 Frame Arrangement

$$I_z = 2(.975)(.05)(1.98)^2 +$$

$$\frac{1}{12} (.05) 3.95^3$$

$$= .382 + .256 = .638$$

$$f_c = - \frac{1,690(1.98)}{.638} = - 5,250 \text{ psi}$$

$$b/t = \frac{.975}{.050 + .025} = 13$$

$$f_{cu} = 31,500 \text{ psi (Reference 46)}$$

$$p_{ult} = \frac{31,500}{5,250} = 6.0 \text{ psi}$$

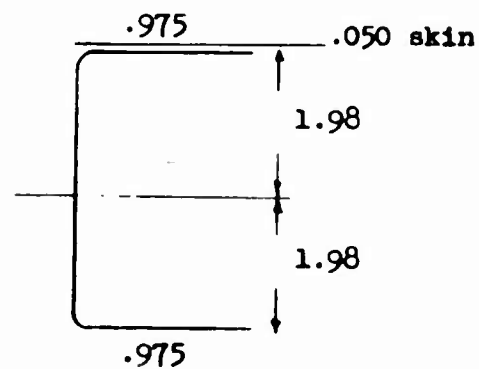

Section B-B (Figure 54)

Attachment of Intercostal to Frame at Sta. 136:

3 - BJ5 rivets in single shear

$$P_s \text{ allowable} = 3(594) = 1,770 \text{ lb. (Reference 60)}$$

$$P = 211.5 \text{ lb.}$$

$$p_{ult} = 1,770/211.5 = 8.4 \text{ psi}$$

Stringer Analysis:

Stringer at B. L. 12 - bottom (s. s. 1507-3A)

Simply supported span = 24.0

Lateral load = 5.8 lb./in.

$$M = \frac{w L^2}{8} = \frac{5.8(24)^2}{8} = 420 \text{ in. -lb.}$$

Frame Analysis:

The frame at station 124 carries a uniform load of 6 lb./in. and is simply supported between the intercostals at W. L. 112 and 137. (Reference Figure 54)

$$\begin{aligned}
 M_{\max} &= \frac{wL^2}{8} \\
 &= 6.0(25)^2 \\
 &= 469 \text{ in.-lb.}
 \end{aligned}$$

$$\begin{aligned}
 I_z &= 2 \left[.95(.05)(1.98)^2 \right] + \frac{1}{12} \left[(.05)(3.95)^3 - .05(1.25)^3 \right] \\
 &= .372 + \frac{1}{12} \left[3.07 - .098 \right] = .372 + .247 \\
 &= .619 \text{ in.}^4
 \end{aligned}$$

$$f_c = \frac{469(1.98)}{.619} = 1,500 \text{ psi}$$

$$b/t = .95/.050 = 19.0$$

$$f_{cu} = 21,500 \text{ psi (Reference 60)}$$

$$P_{\text{ult}} = \frac{21,500}{1,500} = 14.3 \text{ psi}$$

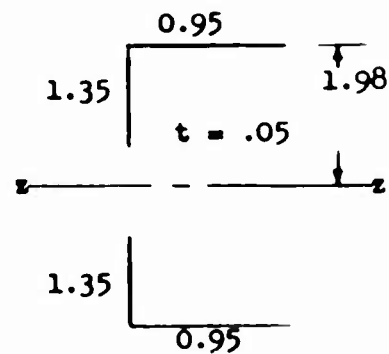

Section A-A (Figure 54)

Intercostal Analysis:

The intercostal at W. L. 137 carries the following loads for a unit pressure on the fuselage.

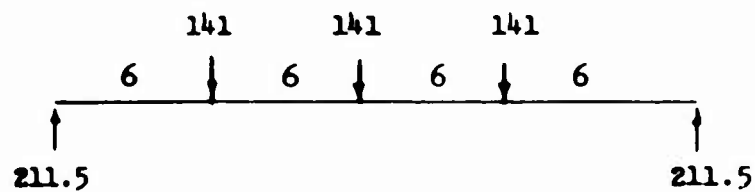

$$M_{\max} = 211.5(12) - 141(6) = 2540 - 850 = 1690$$

Lateral motion (z) is prevented by skin.

$$\begin{aligned}\bar{z} &= \frac{1.01(.04)(.5) + .23(.04)(1.01)}{.696(.072) + 1.24(.04)} \\ &= \frac{.020 + .0093}{.050 + .050} \\ &= .293 \text{ in.}\end{aligned}$$

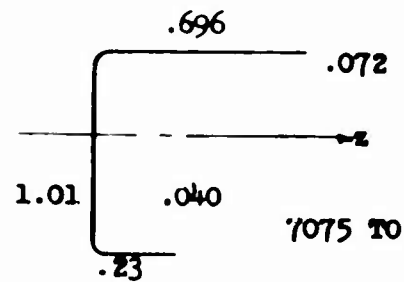

$$\begin{aligned}I_z &= .696(.072)(.293)^2 + .23(.04)(.717)^2 + \frac{1}{12} (.04)(1.01)^3 + \\ &\quad .04(1.01)(.207)^2 \\ &= .0043 + .0047 + .0034 + .0012 \\ &= .0141 \text{ in.}^4\end{aligned}$$

$$f_c = \frac{420(.293)}{.0141} = -8,728 \text{ psi}$$

$$f_t = \frac{420(.717)}{.0141} = 21,357 \text{ psi}$$

$$b/t = .696/((.040) + .016) = 12.4$$

$$f_{cu} = 35,000 \text{ psi (Reference 60)}$$

$$f_{tu} = 76,000 \text{ psi (Reference 46)}$$

$$P_{ult} = \frac{76,000}{21,357} = 3.56 \text{ psi}$$

Zone 4 (Reference Figure 22)

Frame Analysis:

The typical frame in this zone is at station 154.5. This frame carries a load of 18.5 lb./in. due to the assumed unit normal pressure on the fuselage. The load is transmitted into the frame through the stringers. The location and magnitude of the applied loads are shown in Figure 55.

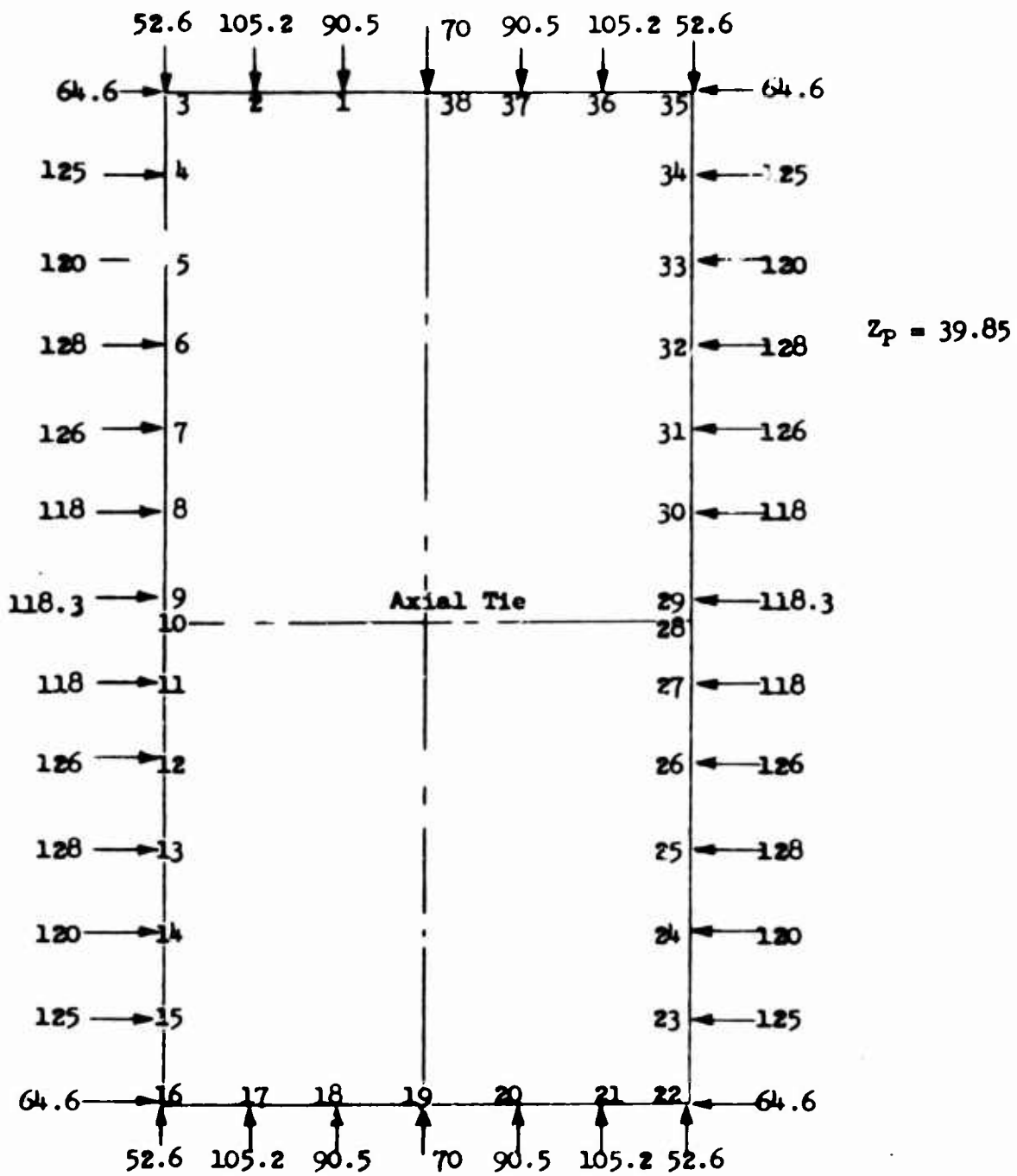

Figure 55. (U) Frame 154.5, Applied Loads due to a Unit Uniform Pressure

TABLE 32 (U)

FRAME 154.5 WITH HORIZONTAL AXIAL TIE SHEARS, BENDING
MOMENTS, AND AXIAL LOADS

Elem. Sta.	Moment (M)	Hor. Force (H)	Vertical Force (V)	Axial Load	Shear
0	-368.	388.	-35.	-388.	-35.
1	-517.	388.	-125.	-388.	-125.
2	-1238.	388.	-231.	-388.	-231.
3	-1875.	324.	-283.	-429.	-30.
4	-427.	199.	-283.	-283.	199.
5	864.	79.	-283.	-283.	79.
6	1374.	-49.	-283.	-283.	-49.
7	1016.	-175.	-283.	-283.	-175.
8	-81.	-293.	-283.	-283.	-293.
9	-1945.	-412.	-283.	-283.	-412.
10	-2508.	332.	-283.	-283.	332.
11	-898.	214.	-283.	-283.	214.
12	482.	88.	-283.	-283.	88.
13	1115.	-40.	-283.	-283.	-40.
14	855.	-160.	-283.	-283.	-160.
15	-185.	-285.	-283.	-283.	-285.
16	-1298.	-350.	-231.	-418.	-28.
17	-852.	-350.	-125.	-350.	125.
18	-130.	-350.	-35.	-350.	35.

TABLE 32 (U) (Cont)

Elem. Sta.	Moment (M)	Hor. Force (H)	Vertical Force (V)	Axial Load	Shear
19	19.	-350.	35.	-350.	-35.
20	-130.	-350.	126.	-350.	-126.
21	-852.	-350.	231.	-350.	-231.
22	-1298.	-285.	283.	-398.	-53.
23	-185.	-160.	283.	-283.	160.
24	855.	-40.	283.	-283.	40.
25	1115.	88.	283.	-283.	-88.
26	482.	214.	283.	-283.	-214.
27	-898.	332.	283.	-283.	-332.
28	-2508.	332.	283.	-283.	-332.
29	-1945.	-293.	283.	-283.	293.
30	-81.	-175.	283.	-283.	175.
31	1016.	-49.	283.	-283.	49.
32	1374.	79.	283.	-283.	-79.
33	864.	199.	283.	-283.	-199.
34	-427.	324.	283.	-283.	-324.
35	-1875.	388.	231.	-449.	-51.
36	-1238.	388.	126.	-388.	126.
37	-517.	388.	35.	-388.	35.
38	-368.	388.	-35.	-388.	-35.

P = -744.

The fuselage frames have axial ties which carry compressive load. It is therefore necessary to determine the maximum compressive load which the axial tie can carry.

Frame 154.5

Local Crippling of Axial Tie

Thickness - .040

Material - 7075 TO

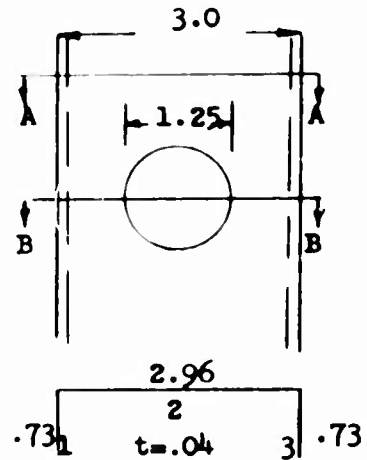

Section A-A:

Element	b	t	b/t	A	f_{cu}	P_{cu}
1	.73	.04	18.2	.029	23000	670
2	2.96	.04	74.0	.118	13500	1590
3	.73	.04	18.2	.029	23000	670

$$P_{cu} = 2,930 \text{ lb.}$$

Section B-B:

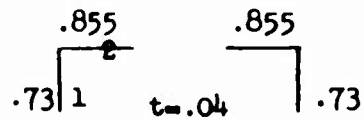

Element	b	t	b/t	A	f_{cu}	P_{cu}
1	.73	.04	18.2	.029	23000	670
2	.855	.04	21.4	.034	16500	630

$$P_{cu} = 2,600 \text{ lb.}$$

Column Buckling of Axial Tie:



The effective length of the tie as a column is a function of K, the frame torsional stiffness factor of the column, and EI/L . (Reference 44)

$$z = \frac{2 \cdot .73(.04)(.365)}{(.730 + .855)2(.04)}$$

$$= \frac{.266}{1.585} = .168 \text{ in.}$$

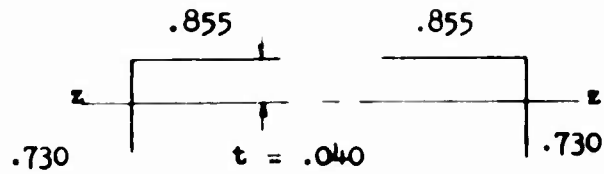

$$I = 2 \left[\frac{1}{12} (.04)(.73)^3 + .73(.04)(.197)^2 + .855(.04)(.165)^2 \right]$$

$$= 2 \left[.0013 + .0011 + .00096 \right]$$

$$= .00672 \text{ in.}^4$$

$$L = 26.0 \text{ inches}$$

The Column Stiffness Factor:

$$EI/L = \frac{10.5 \times 10^6 (.00672)}{26} = 2.71 \times 10^3 = 2,710$$

Frame Torsion Spring Constant:

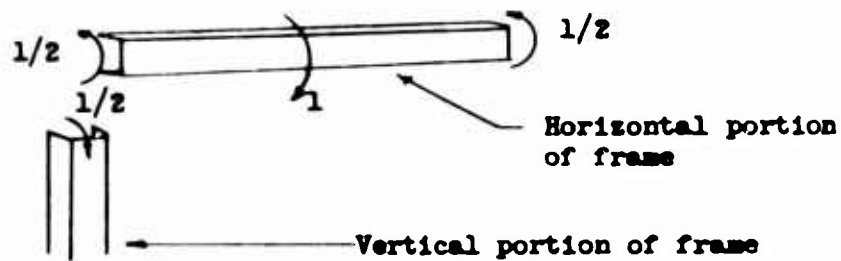

Vertical Portion:

$$1/2 \left(\overbrace{\hspace{2cm}} \right) 1/2$$

$$L = 26.0$$

$$I = .00672$$

$$y''' = \frac{M}{EI} = -\frac{1}{2EI}$$

$$y' = \frac{-x}{2EI} + c$$

$$y' = 0 \text{ at } x = 1/2$$

$$c = -\frac{1}{4EI}$$

$$\begin{aligned} \text{at } x = 0 \quad y' &= -\frac{1}{4EI} = \frac{26}{4(10.5 \times 10^6)(.00672)} \\ &= \frac{26}{28.2 \times 10^4} = 0.93 \times 10^{-4} \text{ rad.} \end{aligned}$$

Horizontal Portion:



$$C = \sum \frac{1}{3} b^3$$

$$= \frac{2}{3} \left[.73(.04)^3 + .855(.04)^3 \right] = 6.343 \times 10^{-5}$$

$$\begin{aligned} \theta &= \frac{TL}{GC} = \frac{0.5(38.5)}{4.2 \times 10^5 (6.343 \times 10^{-5})} \\ &= \frac{19.25}{26.6 \times 10^1} = .0725 \text{ rad./in.-lb.} \end{aligned}$$

$$K = \frac{1}{.0725} = 13.8 \text{ rad./in.-lb.}$$

$$\frac{K}{EI/L} = \frac{13.8}{2,710} = .0051$$

$$\frac{L_e}{L} = 1.0$$

The Buckling Load for the Axial Tie:

$$P_B = \frac{\pi^2 EI}{L^2} = \frac{9.86(10.5 \times 10^6)(.00672)}{26^2} = \frac{695 \times 10^3}{675} = 1,030 \text{ lb.}$$

The maximum load which can be carried by the axial tie before failure occurs by buckling is 1,030 lb.

Frame 154.5 has two axial ties: one at B. L. 1.5 on the right and one at B. L. 28.0 on the left. A comparison of the frame bending moments, without any tie and with only one tie at the extreme left, indicates that the tie at the extreme left does not reduce the maximum bending moment significantly. Therefore it is assumed that this tie does not exist and the moment distribution with the centrally located tie is used for analysis.

Analysis for Unit Pressure:

Axial Tie

Load in axial tie = 744 lb. (Reference Table 32)

Allowable load = 1,030 lb.

$P_{ult} = 1,030/744 = 1.385$ psi

Frame: Skin, Top - .032

Bottom - .040

L. H. - R. H. - .040

Station 28 = M = - 2,508 in. -lb. (Reference Table 32)

$$\bar{z} = \frac{.072(.73)(2.98) + 2.98(.040)(1.44)}{.73(.072 + .04) + 2.98(.04)}$$

$$= \frac{.1566 + .1776}{.082 + .119}$$

$$= .3342/.201 = 1.66 \text{ in.}$$

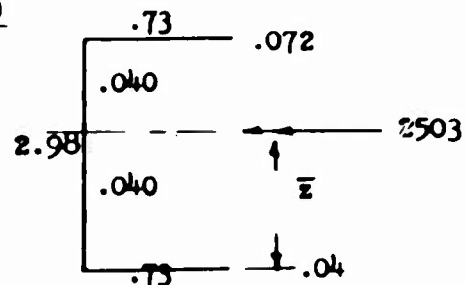

$$I = \frac{1}{12} (.04)(2.98)^3 + .04(2.98)(.17)^2 + .73(0.072)(1.32)^2 +$$

$$.73(.04)(1.66)^2$$

$$= .088 + .0034 + .092 + .080 = .2634 \text{ in.}^4$$

$$f_c = \frac{2,508(1.66)}{.2634} = 15,806 \text{ psi}$$

$$b/t = .73/.04 = 18.3$$

$$f_{cu} = 23,000 \text{ psi (Reference 60)}$$

$$P_{ult} = \frac{23,000}{15,806} = 1.450 \text{ psi}$$

The frame is capable of carrying 1.45 psi (ultimate) but the axial tie will buckle at 1.385 psi (ultimate). P_{ult} (for frame 154.5) = 1.385 psi.

Stringer Analysis:

Typical stringer in zone 4:

S.S 1507-3A 7075 T0

Skin .032 2024 T3

$$\bar{z} = \frac{.23(.04)(1.025) + 1.025(.04)(.513)}{.70(.072 + 1.255(.04))}$$

$$= \frac{.0094 + .0210}{.050 + .050}$$

$$= .304 \text{ in.}$$

$$I_z = .70(.072)(.304)^2 + .23(.04)(.721)^2 + \frac{1}{12} (.04)(1.025)^3 + 1.025(.04)(.209)^2$$

$$= .0047 + .0048 + .0036 + .0018$$

$$= .0149 \text{ in.}^4$$

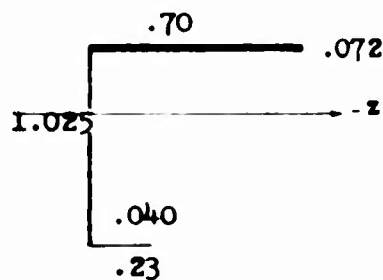

Lateral load = 6.5 lb./in.

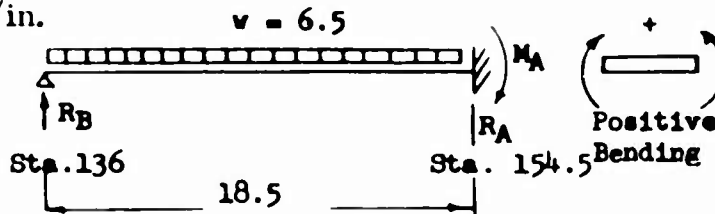

$$M_{\max A} = -\frac{wl^2}{8} \text{ (negative)}$$

$$M_{\max} = +\frac{9}{128} wl^2 \text{ (positive)}$$

$$R_A = \frac{3}{8} wl \quad R_B = \frac{5}{8} wl$$

Negative Bending:

$$M = \frac{wl^2}{8} = \frac{6.5(18.5)^2}{8} = 278 \text{ in. -lb.}$$

$$f_c = \frac{278(.721)}{.0149} = -13,450 \text{ psi}$$

$$f_t = \frac{278(.305)}{.0149} = 5,670 \text{ psi}$$

$$b/t = \frac{.230}{.04} = 5.75$$

$$f_{cu} = 70,000 \text{ psi (Reference 60)}$$

$$P_{ult} = \frac{70,000}{13,450} = 5.2 \text{ psi}$$

Positive Bending:

$$M = \frac{9}{128} wl^2 = 157 \text{ in. -lb.}$$

$$f_c = \frac{157(.304)}{.0149} = -3,200 \text{ psi}$$

$$f_t = \frac{157(.721)}{.0149} = 7,600 \text{ psi}$$

$$b/t = .70/.056 = 12.5$$

$$f_{cu} = 29,000 \text{ psi (Reference 60)}$$

$$P_{ult} = \frac{29,000}{3,200} = 9.05 \text{ psi}$$

Zone 5 (Reference Figure 21)

The typical frame in this zone is at F. S. 191.5. This frame is the same as, and therefore has the same capability as, the frame at F. S. 154.5 (Zone 4).

The critical stringer is a SS1507-3A which is fixed at F. S. 191.5 and simply supported at F. S. 210. The stringer is therefore identical with the critical stringer in zone 4 and has the same ultimate capability.

Zone 6 (Reference Figure 21)

The representative frame in this zone is at F. S. 229.0. This frame is identical with the frame at F. S. 191.5 (zone 5) and therefore has the same ultimate capability of 1.385 psi.

The critical stringer is a SS1507-7H stringer adjacent to the longeron. The stringer carries a uniform load, due to the unit pressure, of 6.375 lb./in. on a span of 18.0 inches. It is simply supported at F. S. 210 and is considered fixed at F. S. 229. The fuselage skin at the critical stringer is .040.

The critical intercostal is a SS1506-F436y which carries a load of 5.2 lb./in., due to the unit pressure. It is simply supported at F. S. 248 and F. S. 283.5. The skin on the side of the fuselage acting with the intercostal is .050.

Stringer Analysis:

$$\begin{aligned}\bar{z} &= \frac{.225(.050)(1.018)(.05)(.501)}{.695(.090) + 1.243(.050)} \\ &= \frac{.0114 + .026}{.063 + .062} = .300 \text{ in.}\end{aligned}$$

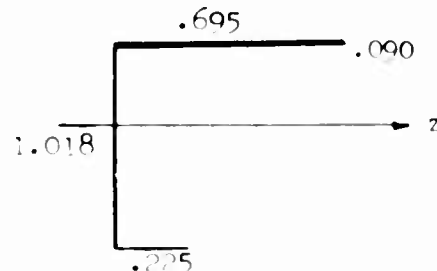

$$\begin{aligned}I_z &= .225(.05)(.718)^2 + .695(.04)(.3)^2 + \\ &\quad \frac{1}{12} (.05)(1.018)^3 + 1.018(.05)(.201)^2\end{aligned}$$

$$I_z = .0058 + .0056 + .0044 + .0021$$

$$= .0129 \text{ in.}^4$$

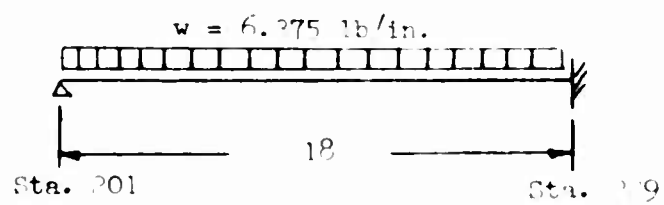

$$M \text{ (positive)} = \frac{9}{128} w l^2$$

$$M \text{ (negative)} = \frac{w l^2}{8}$$

$$M \text{ (positive)} = \frac{9}{128} (6.375)(18)^2 = + 145 \text{ in.-lb.}$$

$$M \text{ (negative)} = \frac{1}{8} (6.375)(18)^2 = - 259 \text{ in.-lb.}$$

Positive Moment:

$$f_x = \frac{M y}{I}$$

$$f_c = \frac{145(.300)}{.0179} = - 2,430 \text{ psi}$$

$$f_t = \frac{145(.702)}{.0179} = 5,700 \text{ psi}$$

$$b/t = .695/.070 = 9.9$$

$$f_{cu} = 37,000 \text{ psi (Reference 60)}$$

$$p_{ult} = \frac{37,000}{2,430} = 15.2 \text{ psi}$$

$$f_{tu} = 76,000 \text{ psi (Reference 46)}$$

$$P_{ult} = \frac{76,000}{5,700} = 13.3 \text{ psi}$$

Negative Moment:

$$f_c = \frac{259(.702)}{.0179} = -10,200 \text{ psi}$$

$$f_t = \frac{259(.300)}{.0179} = +4,330 \text{ psi}$$

$$b/t = 0.225/.05 = 4.5$$

$$f_{cu} = 73,000 \text{ psi (Reference 60)}$$

$$P_{ult} = \frac{73,000}{10,200} = 7.15 \text{ psi}$$

Intercostal Analysis:

Material: Skin 2024 T3

Intercostal 7075 T6

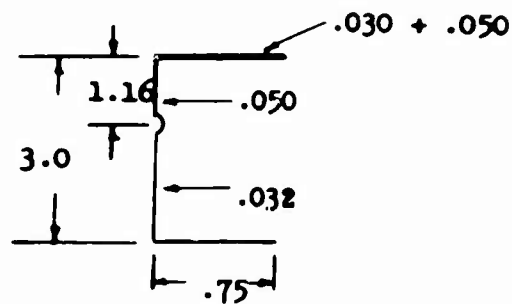

$$\begin{aligned} \bar{z} &= \frac{.75(.032)(3.0) + 1.84(.032)(2.08) + 1.16(.05)(.58)}{1.16(.05) + .75(.10) + 1.84(.032) + .75(.032)} \\ &= \frac{.072 + .122 + .034}{.058 + .075 + .054 + .024} \\ &= \frac{.228}{.216} = 1.06 \text{ in.} \end{aligned}$$

$$\begin{aligned} I_z &= .75(.032)(1.94)^2 + .75(.10)(1.06)^2 + \\ &\quad \frac{1}{12} (.05)(1.16)^3 + 1.16(.05)(.48)^2 + \\ &\quad \frac{1}{12} (.032)(1.84)^3 + 1.84(.032)(1.02)^2 \end{aligned}$$

$$I_z = 0.040 + .084 + .0065 + .013 + \\ 0.0166 + .061 \\ = 0.271 \text{ in.}^4$$

$$M = \frac{wl^2}{8} = \frac{5.70(35.5)^2}{8} = 895 \text{ in.-lb.}$$

$$f_c = \frac{895(1.06)}{.271} = -3,500 \text{ psi}$$

$$f_t = \frac{895(1.94)}{.271} = 6,400 \text{ psi}$$

$$b/t = .75/.075 = 10$$

$$f_{cu} = 37,000 \text{ psi (Reference 60)}$$

$$P_{ult} = \frac{37,000}{3,500} = 10.6 \text{ psi}$$

$$f_{tu} = 76,000 \text{ psi (Reference 46)}$$

$$P_{ult} = \frac{76,000}{6,400} = 11.9 \text{ psi}$$

Zone 7 (Reference Figure 21)

The critical intercostal is identical to that of zone 6 and therefore has an ultimate capability of 10.6 psi.

The typical stringer in this zone is a SS1507-7H which is adjacent to the longeron. It carries a uniform load of 4.5 lb./in. on a span of 18 inches.

The frames in this zone have no bending continuity, and therefore serve only as lateral supports for the intercostals. The pressure loading is carried by the bulkheads at F. S. 400 and 435.5.

Stringer Analysis:

$$\begin{aligned}\bar{z} &= \frac{.225(.03)(.988) + .988(.05)(.494)}{.695(.10) + .988(.05) + .225(.05)} \\ &= \frac{.011 + .024}{.0645 + .049 + .011} \\ &= \frac{.035}{.1295} = .270 \text{ in.}\end{aligned}$$

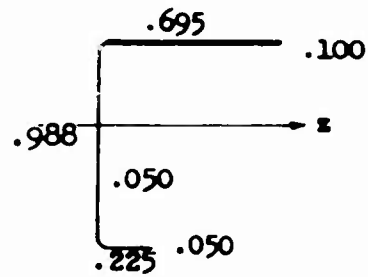

$$\begin{aligned}I_z &= .225(.05)(.72)^2 + .695(.10)(.27)^2 + \frac{1}{12}(.05)(.988)^3 + \\ &\quad .488(.05)(.22)^2 \\ &= .0058 + .0051 + .0040 + .0024 \\ &= .0173 \text{ in.}^4\end{aligned}$$

$$M \text{ (positive)} = 9/128 \text{ } w l^2$$

$$M \text{ (negative)} = 1/8 \text{ } w l^2$$

Positive Moment:

$$\begin{aligned}M \text{ (positive)} &= 9/128 (4.5)(18)^2 \\ &= 103 \text{ in.-lb.}\end{aligned}$$

$$f_c = \frac{103(.27)}{.0173} = -1,600 \text{ psi}$$

$$f_t = \frac{103(.72)}{.0173} = 4,290 \text{ psi}$$

$$b/t = .695/.075 = 9.27$$

$$f_{cu} = 37,500 \text{ psi (Reference 60)}$$

$$f_{tu} = 76,000 \text{ psi (Reference 46)}$$

$$P_{ult} = 76,000/4,290 = 17.75 \text{ psi}$$

Negative Moment:

$$M \text{ (negative)} = \frac{1}{8} (4.5)(18)^2 = 182 \text{ in. -lb.}$$

$$f_c = \frac{182(.72)}{.0173} = -7,600 \text{ psi}$$

$$f_t = \frac{.82(.27)}{.0173} = 2,850 \text{ psi}$$

$$b/t = .225/.05 = 4.5$$

$$f_{cu} = 73,000 \text{ psi (Reference 60)}$$

$$P_{ult} = 73,000/7,600 = 9.6 \text{ psi}$$

Zone 8-9 (Reference Figure 23)

Frame at F. S. 453.5 is common to both zones 8 and 9. The load on the frame due to a unit pressure is 18.5 lb./in. and is applied at the stringer stations (Reference Figure 56).

The stringer which is critical is a SS1507-7H stringer on the upper portion of the fuselage where the skin is .040. The load is 6.375 lb./in., due to the unit pressure, and the stringer is considered simply supported at F. S. 435.5 and fixed at F. S. 453.5.

Frame Analysis:

Column Buckling Load of Axial Tie:

Simply supported length = 36.5 in.

$$\bar{z} = \frac{.73(.040)(.365)(2)}{2[.73 + .73](.404)}$$

$$= .183 \text{ in.}$$

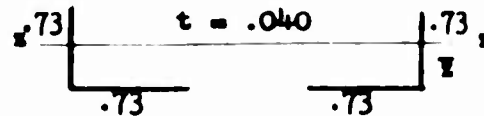

$$I_z = 2 \left[\frac{1}{12} (.04)(.73)^3 + .04(.73)(.182)^2 + .73(.04)(.183)^2 \right]$$

$$= 2 [.0013 + .00097 + .00097]$$

$$= .00648 \text{ in.}^4$$

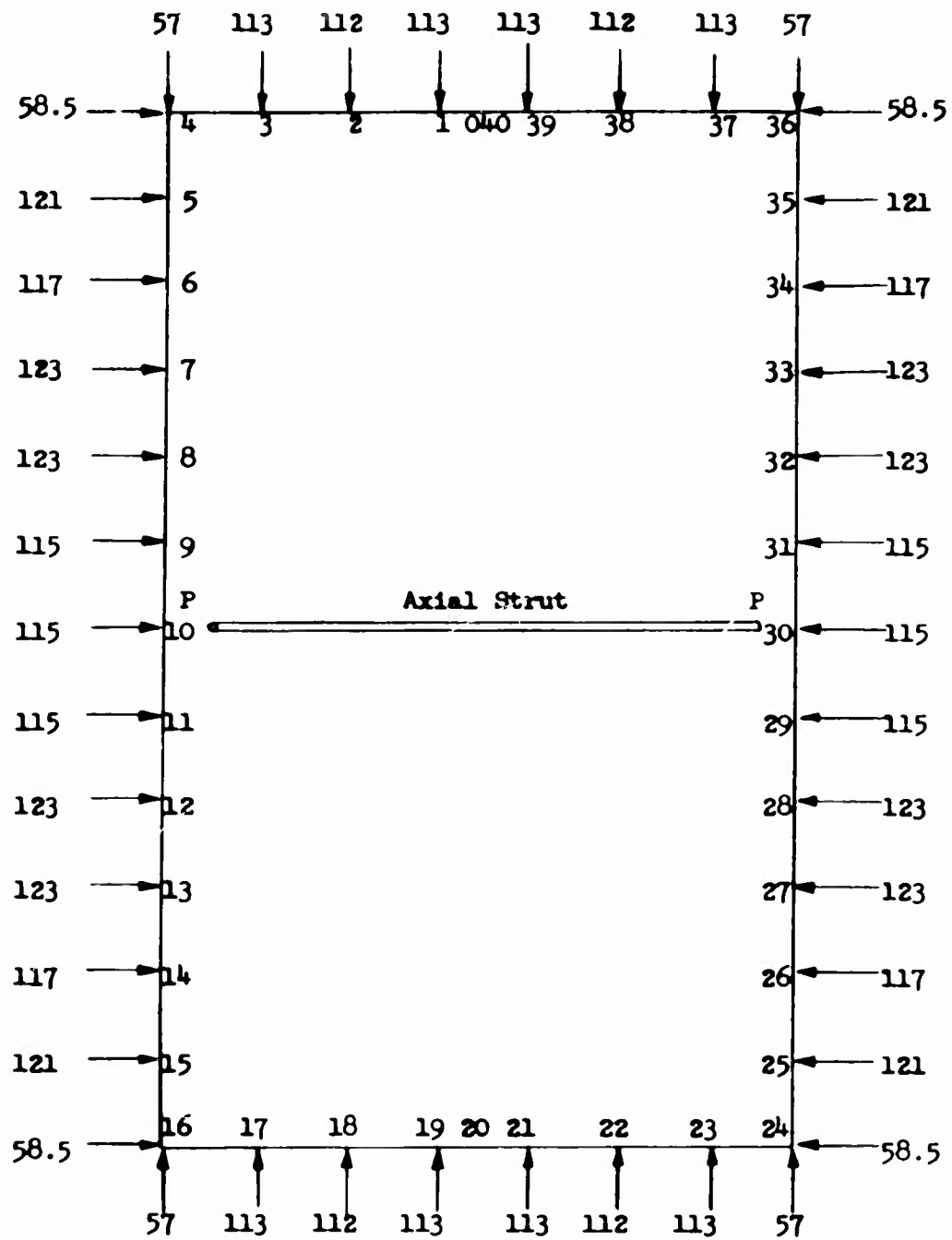

Figure 56. (U) Applied Loads to Frame 453.5 due to a Unit Uniform Pressure

$$P_B = \frac{\pi^2 EI}{L^2} = \frac{9.86 (10.5 \times 10^6) (.00648)}{36.5^2} = \frac{670 \times 10^3}{1330}$$

$$= 503 \text{ lb.}$$

Compressive load in axial tie for a unit fuselage pressure = -691 lb.
(Reference Table 33)

$$P_{ult} = \frac{503}{691} = 0.726 \text{ psi}$$

Bending in the Frame:

Section 17 (Reference Table 33)

$$M = 1,255 \text{ in.-lb.}$$

$$P_c = 370 \text{ lb.}$$

$$A = (2.96 + 1.48) .040 = .177 \text{ in.}^2$$

$$I = 2(.73)(.04)(1.48)^2 +$$

$$\frac{1}{12} (.04)(2.96)^3$$

$$= .128 + .086 = .214 \text{ in.}^4$$

$$f_c = \frac{-370}{.177} + \frac{-1255(1.48)}{.214}$$

$$= -2,100 - 8,700 = -10,800 \text{ psi}$$

$$b/t = 18.2$$

$$f_{cu} = 23,000 \text{ psi (Reference 60)}$$

$$P_{ult} = \frac{23,000}{10,800} = 2.13 \text{ psi}$$

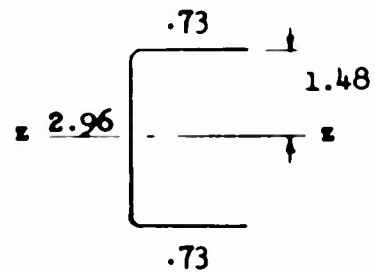

TABLE 33 (U)

FRAME 453.5 WITH HORIZONTAL AXIAL TIE SHEARS,
BENDING MOMENTS, AND AXIAL LOADS

ZP = 38.000					
Elem. Sta.	Moment (M)	Hor. Force (H)	Vertical Force (V)	Axial Load	Shear
0	870.	369.	0.	-369.	0.
1	870.	369.	-113.	-369.	-113.
2	237.	369.	-225.	-369.	-225.
3	-1046.	369.	-338.	-369.	-338.
4	-2112.	311.	-395.	-499.	-80.
5	-755.	190.	-395.	-395.	190.
6	479.	73.	-395.	-395.	73.
7	945.	-50.	-395.	-395.	-50.
8	589.	-173.	-395.	-395.	-173.
9	-537.	-288.	-395.	-395.	-288.
10	-2064.	287.	-395.	-395.	287.
11	-239.	172.	-395.	-395.	172.
12	865.	49.	-395.	-395.	49.
13	1223.	-74.	-395.	-395.	-74.
14	745.	-191.	-395.	-395.	-191.
15	-493.	-312.	-395.	-395.	-312.
16	-2321.	-370.	-338.	-501.	-23.
17	-1255.	-370.	-225.	-370.	225.
18	27.	-370.	-113.	-370.	113.
19	660.	-370.	0.	-370.	-0.
20	660.	-370.	0.	-370.	-0.
21	660.	-370.	113.	-370.	-113.
22	27.	-370.	225.	-370.	-225.

TABLE 33 (U) (Cont)

FRAME 453.5 WITH HORIZONTAL AXIAL TIE SHEARS,
BENDING MOMENTS, AND AXIAL LOADS

ZP = 38.00					
Elem. Sta.	Moment (M)	Hor. Force (H)	Vertical Force (V)	Axial Load	Shear
23	-1255.	-370.	338.	-370.	-338.
24	-2321.	-312.	395.	-500.	-59.
25	-493.	-191.	395.	-395.	191.
26	745.	-74.	395.	-395.	74.
27	1223.	49.	395.	-395.	-49.
28	865.	172.	395.	-395.	-172.
29	-239.	287.	395.	-395.	-287.
30	-2064.	402.	395.	-395.	-402.
31	-537.	-173.	395.	-395.	173.
32	589.	-50.	395.	-395.	50.
33	945.	73.	395.	-395.	-73.
34	479.	190.	395.	-395.	-190.
35	-755.	311.	395.	-395.	-311.
36	-2112.	369.	338.	-500.	-22.
37	-1046.	369.	225.	-369.	225.
38	237.	369.	113.	-369.	113.
39	870.	369.	0.	-369.	0.
40	870.	369.	0.	-369.	0.

P = -691.

Section Halfway Between 16 and 17 (Reference Table 33):

$$P_c = (-501 - 370)/2 = -435$$

$$M = -\frac{1255 - 2321}{2} = -1,790 \text{ in-lb.}$$

$$A = (4.26 + 1.46) \cdot 0.04$$

$$= .229 \text{ in.}^2$$

$$I_z = 2(.73)(.04)(2.13)^2 + \frac{1}{12} (.04)(4.26)^3$$

$$= .264 + .256 = .520 \text{ in.}^4$$

$$f_c = \frac{-435}{.229} - \frac{1290(2.13)}{.520}$$

$$= -1,900 - 7,300 = -9,200 \text{ psi}$$

$$b/t = 18.2$$

$$f_{cu} = 23,000 \text{ psi (Reference 60)}$$

$$P_{ult} = 2.50 \text{ psi}$$

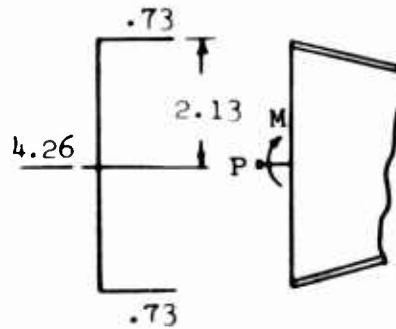

The frame has an ultimate capability of 2.13 psi but column failure of the axial tie is critical.

Capability of Frame: $P_{ult} = 0.726 \text{ psi}$

Stringer Analysis:

$$\bar{z} = .270 \text{ in.}$$

$$I_z = .0173 \text{ in.}^4$$

$$M \text{ (positive)} = \frac{9}{128} w l^2$$

$$M \text{ (negative)} = \frac{1}{8} w l^2$$

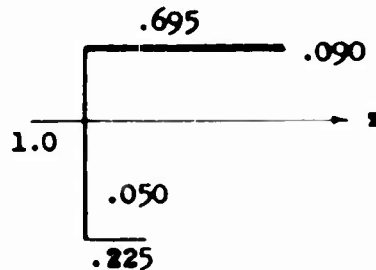

Positive Moment:

$$M = \frac{9}{128} (6.375) (18)^2 = 145 \text{ in. -lb.}$$

$$f_c = \frac{145(.27)}{.0173} = -2,270 \text{ psi}$$

$$f_t = \frac{145(.73)}{.0173} = 6,100 \text{ psi}$$

$$b/t = .695/.070 = 9.93$$

$$f_{cu} = 37,000 \text{ psi (Reference 60)}$$

$$P_{ult} = 37,000/2,270 = 16.3 \text{ psi}$$

$$f_{tu} = 76,000 \text{ psi (Reference 46)}$$

$$P_{ult} = 76,000/6,100 = 12.4 \text{ psi}$$

Negative Moment:

$$M = \frac{1}{8} (6.375) (18)^2 = 258 \text{ in. -lb.}$$

$$f_c = \frac{258(.73)}{.0173} = -10,900 \text{ psi}$$

$$f_t = \frac{258(.27)}{.0173} = 4,000 \text{ psi}$$

$$b/t = .225/.05 = 4.5$$

$$f_{cu} = 73,000 \text{ psi (Reference 60)}$$

$$P_{ult} = 73,000/10,900 = 6.7 \text{ psi}$$

Zone 9 (Reference Figure 22)

The frame at F. S. 510 carries nominally the same load and has the same section properties as the frame at F. S. 453.5. We can therefore assume that both frames have the same ultimate capability of 0.726 psi.

The stringer which is critical is the same as the one in zone 8 and therefore has an ultimate capability of 6.7 psi.

Zones 10, 11, and 12 (Reference Figure 22)

The main landing gear support structure consists of zones 10, 11, and 12. There are no frames, and therefore only the stringer capabilities can be evaluated.

It should be noted that besides the load from the pressure on the top and bottom of the structure, the stringers carry a compressive load which is transmitted from the fore and aft fairing.

Zone 11-12

Stringer: 1.75 x 1.25 x .125 simply supported (extrusion) over a span of 33.5 inches.

Load: For unit pressure: 10.75 lb./in.
a .050 skin acts with the stringer in resisting bending

$$\bar{y} = \frac{1.80(.125)(.42) + 1.125(.175)(.088)}{1.80(.125) + 1.125(.175)}$$

$$= \frac{.224}{.422} = .530 \text{ in.}$$

$$I_z = \frac{1}{12} (.125)(1.71)^3 + 1.71(.125)(.408)^2 + 1.19(.175)(.442)^2$$

$$= .129 \text{ in.}^4$$

$$f_x = -\frac{P}{A} + \frac{M_{zy}}{I_z}$$

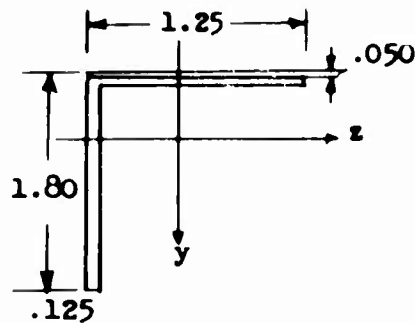

w lb./in.

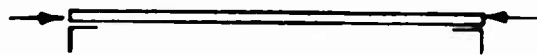

$$P = 14(10.75) = 151 \text{ lb.}$$

$$M_z = wj^2 \left(\sec \frac{1}{2} U - 1 \right) \text{ (Reference 45)}$$

$$j = \left[\frac{EI}{P} \right]^{1/2}$$

I = moment of inertia about the horizontal axis

$$U = 1/j$$

$$j = \frac{10.5 \times 10^6 \times (.129)^{1/2}}{151} = 95.0$$

$$U = 33.5/95 = .353 \text{ radians}$$

$$\sec. \frac{1}{2} U = \sec. (.177) = 1.0152$$

$$M_z = 10.75(95)^2 [1.0152 - 1] = 1,480 \text{ in. -lb.}$$

$$f_x = \frac{-151}{.422} + \frac{1,480 y}{.129}$$

$$f_c = -360 - \frac{1,480(.53)}{.129}$$

$$= -6,460 \text{ psi}$$

$$f_t = -360 + \frac{1,480(1.27)}{.129}$$

$$= 14,240 \text{ psi}$$

Horizontal Leg:

$$b/t = 1.19/.150 = 7.95$$

$$f_{cu} = 67,000 \text{ psi (Reference 60)}$$

$$f_{tu} = 76,000 \text{ psi (Reference 46)}$$

$$P_{ult} = \frac{76}{14.24} = 5.32 \text{ (tension)}$$

Zone 10 - Upper

Stringer 1.5 x 1.25 x .094 extrusion 7075 T6

Skin - .064 in.

Simply supported span = 27.5

Lateral load = 9.25 lb./in.

Compressive load = 10 (9.25) = 92.5 lb.

$$M = wj^2 (\text{sec. } 1/2 U-1)$$

$$j^2 = EI/P$$

$$U = 1/j$$

$$\begin{aligned} \bar{z} &= \frac{1.203(0.158)(.601)}{1.426(.094) + 1.203(.158)} \\ &= \frac{.114}{.324} = .352 \text{ in.} \end{aligned}$$

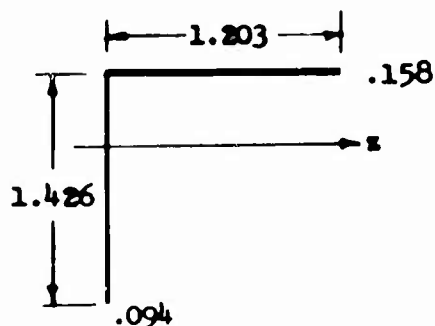

$$\begin{aligned} I_z &= \frac{1}{12} (.094)(1.426)^3 + 1.426(.094)(.419)^2 + 1.203(.158)(.294)^2 \\ &= .0626 \text{ in.}^4 \end{aligned}$$

$$j^2 = \frac{10.5 \times 10^6 (.0626)}{92.5} = 7,100$$

$$j = 84.5$$

$$U = \frac{27.5}{84.5} = .326$$

$$\text{sec. } 1/2 U = \text{sec.} (.163) = 1.0135$$

$$M = 9.25 (7,100)(.0135) = 885 \text{ in. -lb.}$$

$$\begin{aligned}
 f_x &= \frac{P}{A} + \frac{M_y}{I} \\
 &= -\frac{92.5}{.324} + \frac{885y}{.0626} \\
 f_c &= -285 - \frac{885(.352)}{.0626} \\
 &= -5,285 \text{ psi} \\
 f_t &= 285 + \frac{885(1.074)}{.0626} \\
 &= 14,865 \text{ psi} \\
 b/t &= 1.203/.126 = 9.55 \\
 f_{cu} &= 55,000 \text{ psi (Reference 60)} \\
 f_{tu} &= 76,000 \text{ psi (Reference 46)} \\
 P_{ult} &= \frac{76}{14.865} = 5.1 \text{ psi}
 \end{aligned}$$

TABLE 34 (U)

BLAST OVERPRESSURES ON YCH-54A DUE TO 105-mm. HOWITZER

Zone	Average Pressure (psi)		Remarks
	Limit	Ultimate	
1	2.0	3.0	Vent for "0" psi
2	1.5	2.25	
3	2.5	3.75	
4	4.0	6.0	
5	7.0	10.5	

TABLE 34 (U) (Cont)

BLAST OVERPRESSURES ON YCH-54A DUE TO 105-mm. HOWITZER

Zone	(Zone 7 Charge)		Remarks
	Average Pressure (psi)		
	Limit	Ultimate	
6	14.0	21.0	Left side) -simultaneous Top) condition
	14.0	21.0	
6	14.0	21.0	Quarter Top) -Skin and Far side) stringers only
	5.0	7.5	
7	8.0	12.0	
8	5.0	7.5	
9	2.25	3.38	
10	8.5	12.75	Upper
	6.0	9.0	Lower
11	19.0	28.5	Upper
	11.0	16.5	Lower
12	15.0	22.5	Upper
	8.5	12.75	Lower

(U) Dynamic Response of YCH-54A Fuselage to Blast Loading

The structure must be analyzed for both static application of ultimate load and repeated application of limit load. In order to properly evaluate the structure for repeated loads the dynamic response of the aircraft due to the blast loading must be defined. This will determine the number of stress cycles for each load application. It follows that the total number of weapon firings multiplied by the stress cycles per load application yields the fatigue design life.

Test data (Reference 49) indicates that the amplitude ratio or response of a helicopter fuselage to blast loads is unity. Using a forcing frequency of 108 radians per second and a natural frequency (w_n) of 690 radians per second, the damping ratio of a typical fuselage is found to be 0.685 (Reference 49). The damping ratio (ζ) is the ratio of the damping constant (c) to the critical damping constant (c_c).

A one-degree-of-freedom damped system is assumed to represent the YCH-54A fuselage plating surface. The system is considered to have a damping ratio of .685 and a natural frequency of 690 radians per second. The forcing function of an exponential blast wave is:

$$F(t) = Fe^{-t/t_i} - t/t_i Fe^{-t/t_i} \text{ (Reference 63)}$$

$$t_i = .04 \text{ sec. (Reference 62)}$$

The equation of motion for a single-degree-of-freedom damped system is:

$$\ddot{x} + 2\zeta w_n \dot{x} + w_n^2 x = F_N(t)$$

$$F_N(t) = F(t)/M = \text{Normalized Forcing Function}$$

The solution of the equation of motion will determine the number of cycles of stress, per load application, which will occur before the response is damped out.

Solution of Equation of Motion:

$$F_N(t) = Fe^{-25t} - 25tFe^{-25t}$$

$$\ddot{x} + 945\dot{x} + 454000x = Fe^{-25t} - 25t Fe^{-25t}$$

$$\left. \begin{array}{l} x(0) = 0 \\ \dot{x}(0) = 0 \end{array} \right\} \text{Initial conditions}$$

Particular Solution

$$x_p = (A + Bt)e^{-25t}$$

Substituting into the differential equation and equating coefficients, we obtain:

$$945B + 885000A = F$$

$$885000B = -25F$$

$$A = .113 \times 10^{-5} F$$

$$B = 2.82 \times 10^{-5} F$$

$$x_p = \left[.113 \times 10^{-5} - 2.82 \times 10^{-5} t \right] F e^{-25t}$$

Complimentary Solution:

$$\ddot{x} + 945\dot{x} + 454000x = 0$$

$$x_c = (A \cos bt + B \sin bt) e^{-at}$$

$$b = 690 \sqrt{1 - (.685)^2} = 500$$

$$a = 690 (.685) = 473$$

$$x_c = (A \cos 500t + B \sin 500t) e^{-473t}$$

$$x(t) = x_c + x_p$$

$$x(t) = \left[A \cos 500t + B \sin 500t \right] e^{-473t} + \left[.113 \times 10^{-5} - 2.82 \times 10^{-5} t \right] F e^{-25t}$$

Initial Conditions:

$$1) \quad x(0) = 0$$

$$2) \quad \dot{x}(0) = 0$$

Utilizing the above initial conditions,

$$1) \quad x(0) = 0$$

$$A = -.113 \times 10^{-5} F$$

$$2) \dot{x}(0) = 0$$

$$\dot{x} = e^{-473t} \left[56.5 \times 10^{-5} F \sin 500t + 500 B \cos 500t \right] +$$

$$\left[-.113 \times 10^{-5} F \cos 500t + B \sin 500t \right] (-473e^{-473t}) +$$

$$\left[.113 \times 10^{-5} - 2.82 \times 10^{-5} t \right] (-25Fe^{-25t})$$

$$B = -.096 \times 10^{-5} F$$

$$x(t) = \left[-.113 \times 10^{-5} F \cos 500t - .096 \times 10^{-5} F \sin 500t \right] e^{-473t} +$$

$$\left[.113 \times 10^{-5} - 2.82 \times 10^{-5} t \right] Fe^{-25t}$$

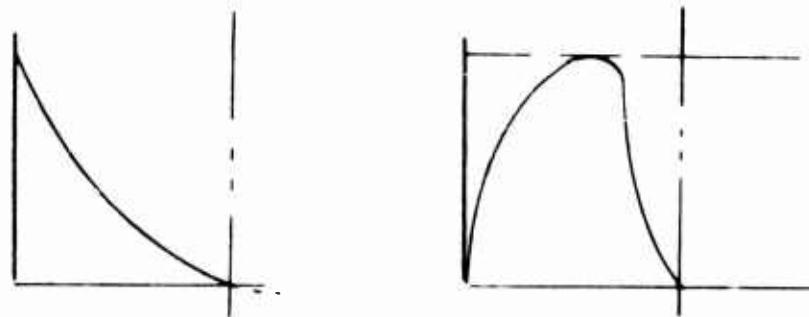

Figure 57. (U) Input and Response of Aircraft Structure to Shock Wave

The previous analysis indicates that for each application of load there will be one cycle of stress. The design is based on 26,700 weapon firings in 1,000 hours. Therefore the structure should be analyzed for the following loads.

- (a) ultimate load
- (b) limit load, 26,700 cycles
 - mean stress = 1/2 peak stress
 - stress amplitude = 1/2 peak stress

(U) Evaluation of Fuselage Skin

The evaluation of the typical skin panels for the blast overpressure load (Table 34) is as follows.

The skin is considered to be acting as a thin plate under uniform normal pressure (Reference 42). The plate efficiency is assumed as .80, and the stress concentration factor K_T is taken as 3.0.

In order to provide a .999 probability of survival, the allowable stress amplitude (f_a^1) is taken from a three sigma S-N curve. This is accomplished by reducing the available two sigma curves by 13 percent for aluminum and 10 percent for steel.

Zone 3

Ultimate Load:

$$P_{ult} = 3.75 \text{ psi}$$

$$a = 24, b = 6, t = .032, 2024 \text{ T3}$$

$$a/b = 4.0$$

$$b/t = 187$$

$$w/t = 3.2$$

$$f_t = 12,000/.80 = 15,000 \text{ psi (Reference 42)}$$

$$f_{tu} = 59,000 \text{ psi (Reference 46)}$$

$$M.S. = 59,000/15,000 - 1 = \text{High}$$

Limit Load:

$$P_{limit} = 2.5 \text{ psi}$$

$$w/t = 2.8 \quad (\text{Reference 42})$$

$$f_a = \frac{11000}{.80(2)} = 6,875 \text{ psi}$$

$$f_a^1 = .87(18,000) = 15,600 \text{ psi (Reference 60)}$$

$$M. S. = \frac{15,600}{6,875} - 1 = \text{High}$$

Zone 4

Ultimate Load:

$$P_{ult} = 6.0 \text{ psi}$$

$$a = 18.5, b = 6.5, t = .032, 2024 T3$$

$$a/b = 2.85$$

$$b/t = 163$$

$$w/t = 3.0 \quad (\text{Reference 42})$$

$$f_t = \frac{16,000}{.80} = 20,000 \text{ psi}$$

$$f_{tu} = 59,000 \text{ psi} \quad (\text{Reference 46})$$

$$M.S. = \frac{59,000}{20,000} - 1 = \text{High}$$

Limit Load:

$$P_{limit} = 4.0 \text{ psi}$$

$$\frac{w}{t} = 2.5 \quad (\text{Reference 42})$$

$$f_a = \frac{12,000}{.80(2)} = 7,500 \text{ psi}$$

$$f_a^1 = .87(18,000) = 15,600 \text{ psi} \quad (\text{Reference 60})$$

$$M.S. = \frac{15,600}{7,500} - 1 = \text{High}$$

Zone 5

Ultimate Load:

$$P_{ult} = 10.5 \text{ psi}$$

$$a = 18.5, b = 6.5, t = .032$$

$$\frac{a}{b} = 2.85$$

$$\frac{b}{t} = 163$$

$$\frac{w}{t} = 3.5 \quad (\text{Reference 42})$$

$$f_t = \frac{20,000}{.80} = 25,000 \text{ psi}$$

$$f_{tu} = 59,000 \text{ psi} \quad (\text{Reference 46})$$

$$\text{M.S.} = \frac{59,000}{25,000} - 1 = \text{High}$$

Limit Load:

$$P_{limit} = 7.0 \text{ psi}$$

$$\frac{\dot{w}}{t} = 3.1$$

$$f_a = \frac{16,000}{.80 (2)} = 10,000 \text{ psi}$$

$$\begin{aligned} f_a^1 &= .87 (18,000) \\ &= 15,600 \text{ psi} \quad (\text{Reference 60}) \end{aligned}$$

$$\begin{aligned} \text{M.S.} &= \frac{15,600}{10,000} - 1 \\ &= + .56 \end{aligned}$$

Zone 6 - Simultaneous Condition, Near Side

Ultimate Load:

$$\begin{aligned}P_{ult} &= 21.0 \text{ psi} \\a &= 19, \quad b = 6.375, \quad t = .050, \quad 2024 \text{ T3} \\ \frac{a}{b} &= 2.98 \\ \frac{b}{t} &= 127.5 \\ f_t &= \frac{42,000}{.80} \\ &= 52,500 \text{ psi} \quad (\text{Reference 42}) \\ f_{tu} &= 59,000 \text{ psi} \quad (\text{Reference 46}) \\ \text{M.S.} &= \frac{59,000}{52,500} - 1 \\ &= + .12\end{aligned}$$

Limit Load:

$$\begin{aligned}P_{limit} &= 14.0 \text{ psi} \\ f_a &= \frac{30,000}{.80(2)} \\ &= 37,500 \text{ psi} \quad (\text{Reference 42}) \\ f_a^1 &= .87 (16,500) \\ &= 14,300 \text{ psi} \quad (\text{Reference 60}) \\ \text{M.S.} &= \frac{14,300}{37,500} - 1 \\ &= - .62\end{aligned}$$

A fatigue problem is indicated.

Quarter top.

Ultimate Load:

$$P_{ult} = 21.0 \text{ psi}$$

$$a = 19.0, \quad b = 6.375, \quad t = .032, \quad 2024 \text{ T3}$$

$$\frac{a}{b} = 2.98$$

$$\frac{b}{t} = 200$$

$$f_t = \frac{40,000}{.80}$$

$$= 50,000 \text{ psi} \quad (\text{Reference 42})$$

$$f_{tu} = 59,000 \text{ psi} \quad (\text{Reference 46})$$

$$\text{M.S.} = \frac{59,000}{50,000} - 1$$

$$= + .18$$

Limit Load:

$$P_{limit} = 14.0 \text{ psi}$$

$$f_a = \frac{34,000}{.80(2)}$$

$$= 21,250 \text{ psi} \quad (\text{Reference 42})$$

$$f_a^1 = .87 (16,500)$$

$$= 14,300 \text{ psi} \quad (\text{Reference 60})$$

$$\text{M.S.} = \frac{14,300}{21,250} - 1$$

$$= - .325$$

A fatigue problem is indicated.

Zone 6 - Far Side

Ultimate Load:

$$P_{ult} = 7.5 \text{ psi}$$

$$a = 19, \quad b = 6.375, \quad t = .050, \quad 2024 \text{ T3}$$

$$\frac{a}{b} = 2.98$$

$$\frac{b}{t} = 127.5$$

$$f_t = \frac{24,000}{.80}$$

$$= 30,000 \text{ psi} \quad (\text{Reference 42})$$

$$f_{tu} = 59,000 \text{ psi} \quad (\text{Reference 46})$$

$$\text{M.S.} = \frac{59,000}{30,000} - 1$$

$$= + .96$$

Limit Load:

$$P_{limit} = 5.0 \text{ psi}$$

$$\frac{w}{t} = 2.0 \quad (\text{Reference 42})$$

$$f_a = \frac{14,000}{.80(2)} = 8,750 \text{ psi}$$

$$f_a^1 = .87 (17,500)$$

$$= 15,200 \text{ psi} \quad (\text{Reference 60})$$

$$\text{M.S.} = \frac{15,200}{8,750} - 1$$

$$= + .74$$

Zone 7

Ultimate Load:

$$P_{ult} = 12.0$$

$$a = 35.5, b = 6.375, + = .040, 2024 T3$$

$$\frac{a}{b} = 5.56$$

$$\frac{b}{t} = 160$$

$$f_t = \frac{24,000}{.80}$$

$$= 30,000 \text{ psi} \quad (\text{Reference 42})$$

$$f_{tu} = 59,000 \text{ psi} \quad (\text{Reference 46})$$

$$\text{M.S.} = \frac{59,000}{30,000} - 1$$

$$= + .97$$

Limit Load:

$$P_{limit} = 8.0 \text{ psi}$$

$$f_a = \frac{20,000}{.80(2)} = 12,500 \text{ psi} \quad (\text{Reference 42})$$

$$f_a^1 = .87 (18,000)$$

$$= 15,600 \text{ psi} \quad (\text{Reference 60})$$

$$\text{M.S.} = \frac{15,600}{12,500} = 1$$

$$= + .25$$

Zone 8

Ultimate Load:

$$P_{ult} = 7.5 \text{ psi}$$

$$a = 18.0, \quad b = 6.375, \quad t = .040 \quad 2024 \text{ T3}$$

$$\frac{a}{b} = 2.85$$

$$\frac{b}{t} = 160$$

$$f_t = \frac{20,000}{.80}$$

$$= 25,000 \text{ psi} \quad (\text{Reference 42})$$

$$f_{tu} = 59,000 \text{ psi} \quad (\text{Reference 46})$$

$$\text{M.S.} = \frac{59,000}{25,000} - 1$$

$$= \text{High}$$

Limit Load:

$$P_{limit} = 5.0 \text{ psi}$$

$$f_a = \frac{15,000}{.80 (2)}$$

$$= 9,300 \text{ psi} \quad (\text{Reference 42})$$

$$f_a^1 = .87 (17500)$$

$$= 15,200 \text{ psi} \quad (\text{Reference 60})$$

$$\text{M. S.} = \frac{15,200}{9,300} - 1$$

$$= + .64$$

Zone 9

Ultimate Load:

$$P_{ult} = 3.38 \text{ psi}$$

Limit Load:

$$P_{limit} = 2.25 \text{ psi}$$

Based on previous calculations, it can be concluded that the M. S. for both ultimate and limit load are high.

Zone 10 - Upper

Ultimate Load:

$$P_{ult} = 12.75 \text{ psi}$$

$$a = 26, \quad b = 10, \quad + = .080, \quad 7075 \text{ T6}$$

$$\frac{a}{b} = 2.6$$

$$\frac{b}{t} = 125$$

$$f_t = \frac{28,000}{.80}$$

$$= 35,000 \text{ psi} \quad (\text{Reference 42})$$

$$f_{tu} = 76,000 \text{ psi} \quad (\text{Reference 46})$$

$$\text{M. S.} = \frac{76,000}{35,000} - 1$$

$$= \text{High}$$

Limit Load:

$$P_{limit} = 8.5 \text{ psi}$$

$$f_a = \frac{17,000}{2 (.80)}$$

$$= 10,600 \text{ psi} \quad (\text{Reference 42})$$

$$f_a^1 = .87 (18,000)$$

$$= 15,600 \text{ psi} \quad (\text{Reference 60})$$

$$\text{M. S.} = \frac{15,600}{10,600} - 1$$

$$= + .48$$

Zone 10 - Lower

Ultimate Load:

$$P_{\text{ult}} = 9.0 \text{ psi}$$

Limit Load:

$$P_{\text{limit}} = 6.0 \text{ psi}$$

Based on the analysis above (Zone 10 Upper), no skin modifications will be required for Zone 10, lower.

Zone 11 - Upper

Panel Size:

$$a = 34.5, \quad b = 10, \quad + = .051 \quad 7075 \quad T6$$

$$\frac{a}{b} = 3.45$$

$$\frac{b}{t} = 196$$

Ultimate Load:

$$P_{\text{ult}} = 28.5 \text{ psi}$$

$$f_t = \frac{49,000}{.80}$$

$$= 61,000 \text{ psi} \quad (\text{Reference 42})$$

$$f_{tu} = 76,000 \text{ psi} \quad (\text{Reference 46})$$

$$\begin{aligned} \text{M.S.} &= \frac{76,000}{61,000} - 1 \\ &= + .24 \end{aligned}$$

Limit Load:

$$P_{\text{limit}} = 19.0 \text{ psi}$$

$$\begin{aligned} f_a &= \frac{33,000}{.80 (2)} \\ &= 20,600 \text{ psi} \quad (\text{Reference 42}) \end{aligned}$$

$$\begin{aligned} f_a^1 &= .87 (16500) \\ &= 14,300 \text{ psi} \quad (\text{Reference 60}) \end{aligned}$$

$$\begin{aligned} \text{M. S.} &= \frac{14,300}{20,600} - 1 \\ &= -.300 \end{aligned}$$

Structural modification will be required.

Zone 11 - Lower

Panel Size:

$$a = 34.5, \quad b = 8, \quad + = .071 \quad 7075 \text{ T6}$$

$$\frac{a}{b} = 4.3$$

$$\frac{b}{t} = 112$$

Ultimate Load:

$$P_{\text{ult}} = 16.5 \text{ psi}$$

$$\begin{aligned} f_t &= \frac{32,500}{.80} \\ &= 40,500 \text{ psi} \quad (\text{Reference 42}) \end{aligned}$$

$$t_{tu} = 76,000 \text{ psi} \quad (\text{Reference 46})$$

$$\begin{aligned} \text{M. S.} &= \frac{76,000}{40,500} - 1 \\ &= + .88 \end{aligned}$$

Limit Load:

$$p_{\text{limit}} = 11.0 \text{ psi}$$

$$\begin{aligned} f_a &= \frac{24,000}{.80 (2)} \\ &= 15,000 \text{ psi} \quad (\text{Reference 42}) \end{aligned}$$

$$\begin{aligned} f_a^1 &= .87 (17,000) \\ &= 14,800 \text{ psi} \quad (\text{Reference 60}) \end{aligned}$$

$$\begin{aligned} \text{M. S.} &= \frac{14,800}{15,000} - 1 \\ &= -.01 \end{aligned}$$

A fatigue problem is therefore indicated.

It can be seen from the preceding analysis that the skins in all zones are capable of carrying ultimate load. However, modification will be required in those areas where the stress amplitudes due to limit load exceed the allowables for a life of 2.70×10^4 cycles. These areas are as follows:

Zone 6 - Left side and top

Zone 11 - Upper

Zone 11 - Lower

(U) STRUCTURAL MODIFICATIONS TO YCH-54A/105-mm. HOWITZER AIRCRAFT/WEAPON COMBINATION

From the analysis performed on the fuselage skin it was found that modifications will have to be made in the following areas:

1. Zone 6 - Left side and top
2. Zone 11 - Upper
3. Zone 11 - Lower

A comparison of the frame and stringer ultimate capabilities (Ref. Table 32) with the actual blast overpressures (Ref. Table 34) indicates that modifications are required in all areas except zones 1, 2, and 3.

It should be noted that the aluminum skin will be replaced by the same thickness of heat-treated steel sheet. This will provide the required capability for the blast loads while insuring that there is no reduction in strength for flight loads.

A list of the structural modifications is given below.

Fuselage Skin:

F. S. 210-400: Replace aluminum skin on right side and top by SAE 4130 steel sheet heat treated to 180 ksi. *

Landing Gear Support Structure Skin:

Left Side

Upper B. L. 40-65. 2: Replace aluminum skin by SAE 4130 steel sheet heat treated to 180 ksi. * Chem-mil to existing thickness.

Lower B. L. 40-65. 2: Replace aluminum skin by SAE 4130 steel sheet heat treated to 125 ksi. Chem-mil to existing thickness.

* Titanium sheet may be substituted for steel sheet, thickness for thickness.

Fuselage Frames:

F. S. 154.5: Replace existing frame by channel 1.0 x 6.0 x 1.0 x .063 7075 T6. Axial tie at B.L. 0 is integral with frame.

F. S. 191.5: Replace existing frame by channel 1.0 x 6.0 x 1.0 x .063 7075 T6. Add .040 steel straps to the outer and inner flanges. Axial tie: Two channels 0.75 x 3.0 x 0.75 x .063 7075 T6 riveted back to back.

F. S. 173: Same as 191.5

F. S. 229: Replace existing frame by channel 1.0 x 6.0 x 1.0 x 0.63 7075 T6. Add .084 steel strap to outer flange and .125 steel strap to the inner flange. Axial tie: Two channels 1.0 x 3.0 x 1.0 x .084 7075 T6 riveted back to back.

F. S. 453.5: Replace existing frame by a channel 1.0 x 6.0 x 1.0 x .063 7075 T6. The axial tie is integral with the frame.

F. S. 490.5, 510, 529.5: Replace existing frame by a channel 1.0 x 4.0 x 1.0 x .063 7075 T6. The axial tie is integral with the frame.

Fuselage Stringers and Intercostals:

F. S. 136-173: Replace stringers on the top and left side by SS-1507-9H stringers.

F. S. 173-210: Add SS1507-3A stringers halfway between existing stringers on top and left side.

F. S. 210-248: At F. S. 219 and F. S. 238.5 on the left side add intermediate support for stringers. Use 1.0 and 4.0 x 1.0 x .063 7075 T6 channel with .050 steel strap on the inner flange.

F. S. 248-400: Replace SS1506-F4 intercostals on the left side by SS1506-F7 intercostals.

F. S. 400-435: Replace existing members on the left side with SS1506-F7 intercostals.

F. S. 435-453.5: Replace existing stringers on the top and left side by SS1507-9H stringers.

Stiffeners - Landing Gear Support Structure, Left Side:

Upper - B. L. 40-65.217: Replace existing stiffeners by Reynolds Die #10067 extruded channels.

Upper - B. L. 65.217-113: Replace existing stiffeners by Reynolds Die #6678 extruded channels.

Lower - B. L. 40-65.217: Replace existing stiffeners by Reynolds Die #10611 extruded channels.

Lower - B. L. 65.217-113: Add extruded angles the same size as existing angles to form built up tee sections.

Fuselage Longerons:

F. S. 210-400 upper left, lower left, and upper right.

Add stiffeners connecting longerons to adjacent intercostals or stringers. Use SS1507-7H stiffeners spaced at 6.0 inches.

Attachments: left side and top.

F. S. 173-248: At all attachments of stringers to frames and bulkheads replace BJ5 rivets by BJ6 rivets.

(U) Fuselage Frames and Stringers

The applied loads to the frames, assuming the unit pressure to be acting on the top and side only during the simultaneous condition, is shown in Figure 58.

Zone 4

Stringers: See analysis of zone 8 (Reference Page 306)

Frame: F. S. 154.4, see analysis of frame at F. S. 453.5 (Reference 306)

Frame 453.5 P_{limit} = 3.62)
 P_{ult} = 5.44) Reference Table 34

Frame 154.5 P_{limit} = 4.0)
 P_{ult} = 6.0) Reference Table 34

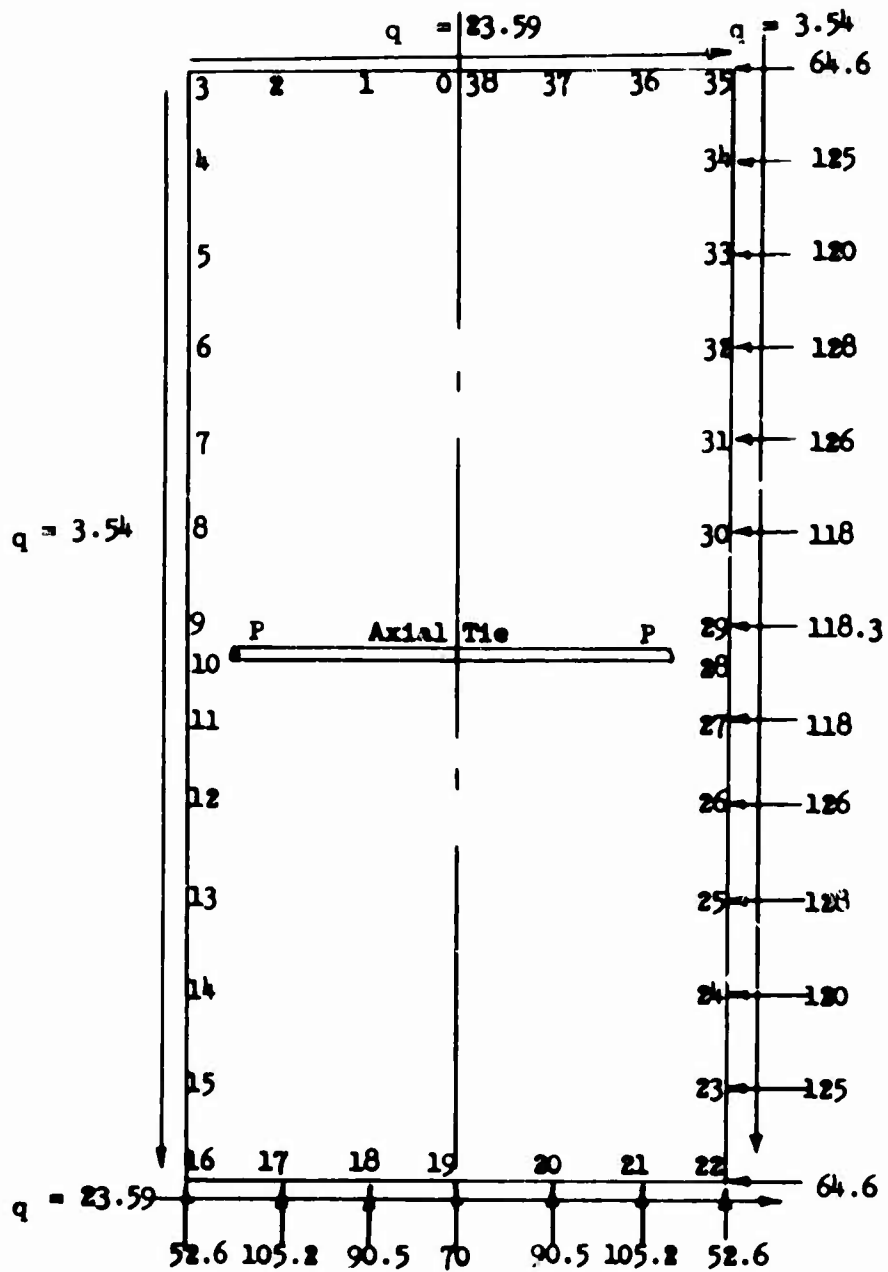

Figure 58. (U) Loading Due to Unit Pressure, Typical Frames 154.5, 191.5, 229, 453.5, 510

TABLE 35 (U)

TYPICAL FRAME WITH HORIZONTAL AXIAL TIE SHEARS, BENDING
MOMENTS, AND AXIAL LOADS

ZP = 29.800					
Elem. Sta.	Moment (M)	Hor. Force (H)	Vertical Force (V)	Axial Load	Shear
0	-827.	173.	369.	-173.	369.
1	590.	73.	369.	-73.	369.
2	2506.	-63.	369.	63.	369.
3	3499.	-193.	357.	369.	167.
4	2789.	-192.	330.	330.	-192.
5	1575.	-192.	307.	307.	-192.
6	360.	-192.	284.	284.	-192.
7	-995.	-192.	259.	259.	-192.
8	-2162.	-192.	236.	236.	-192.
9	-3349.	-192.	214.	214.	-192.
10	-3602.	177.	209.	209.	177.
11	-2715.	177.	191.	191.	177.
12	-1536.	177.	169.	169.	177.
13	-220.	177.	143.	143.	177.
14	968.	177.	120.	120.	177.
15	2156.	177.	97.	97.	177.
16	2945.	177.	125.	216.	8.
17	2885.	47.	228.	47.	-228.
18	1779.	-89.	318.	-89.	-318.
19	577.	-189.	388.	-189.	-388.
20	-922.	-289.	479.	-289.	-479.
21	-3471.	-425.	584.	-425.	-584.

TABLE 35 (U) (Cont)

TYPICAL FRAME WITH HORIZONTAL AXIAL TIE SHEARS, BENDING
MOMENTS, AND AXIAL LOADS

ZP = 29.800					
Elem. Sta.	Moment (M)	Hor. Force (H)	Vertical Force (V)	Axial Load	Shear
22	-4777.	-490.	639.	-777.	-212.
23	-2993.	-364.	614.	-614.	364.
24	-660.	-244.	591.	-591.	244.
25	893.	-124.	568.	-568.	124.
26	1749.	2.	543.	-543.	-2.
27	1704.	120.	520.	-520.	-120.
28	1097.	120.	503.	-503.	-120.
29	1439.	-132.	497.	-497.	132.
30	2241.	-14.	475.	-475.	14.
31	2292.	112.	452.	-452.	-112.
32	1439.	240.	427.	-427.	-240.
33	-159.	360.	404.	-404.	-360.
34	-2536.	485.	381.	-381.	-485.
35	-4787.	549.	354.	-652.	-50.
36	-3981.	420.	366.	-420.	366.
37	-2080.	284.	366.	-284.	366.
38	-675.	184.	366.	-184.	366.
P = -370.					

Limit Load:

$$f_a = 6,125 \frac{6}{5.44} = 6,750 \text{ psi (Reference page 306)}$$

$$f_a' = .87(17,500) = 15,200 \text{ psi (Reference 60)}$$

$$\text{M. S.} = 15,200/6,125 - 1 = \text{high}$$

Ultimate Load:

$$f_c = \frac{6}{5.44} (21,779) = 24,000 \text{ psi (Reference page 306)}$$

$$f_{cu} = 26,000 \text{ psi (Reference 60)}$$

$$\text{M. S.} = 26,000/24,000 - 1 = + .08$$

Zone 5

$$\begin{array}{l} P_{ult} = 10.5 \text{ psi }) \\ P_{limit} = 7.0 \text{ psi }) \end{array} \text{ Reference Table 34}$$

Stringers:

Limit Load:

Negative Bending: (Reference page 266)

$$f_c = 7/4 (-26,900) = -47,000 \text{ psi}$$

$$f_t = 7/4 (11,340) = 19,800 \text{ psi}$$

Positive Bending: (Reference page 266)

$$f_c = 7/4 (-6,400) = -11,200 \text{ psi}$$

$$f_t = 7/4 (15,200) = 26,600 \text{ psi}$$

The stringer is critical for limit load on the compression side in negative bending.

$$f_a = 23,500 \text{ psi}$$

$$f_a' = .90 (39,000) = 35,000 \text{ psi (Reference 60)}$$

$$\text{M.S. (Limit)} = 35,000/23,500 - 1 = + .49$$

Ultimate Load:

$$f_c = 1.5 (47,000) = 70,000 \text{ psi}$$

$$b_t = .23/.04 = 5.75$$

$$f_{cu} = 70,000 \text{ psi (Reference 60)}$$

$$\text{M.S. (ultimate)} = 0.0$$

Frame 191.5

Axial Tie:

Compressive load due to unit pressure = 370 lb. (Reference Table 35)

Ultimate compressive load = 10.5 (370)
= 3,880 lb.

Limit compressive load = 7.0 (370)
= 2,580 lb.

Existing moment of inertia = .00672 in.⁴ (Reference page 274)

$$I' = \frac{1}{12} (2)(.063)(1.5)^3$$

$$= .035 \text{ in.}^4$$

$$I'/I = \frac{.035}{.00672} = 5.2$$

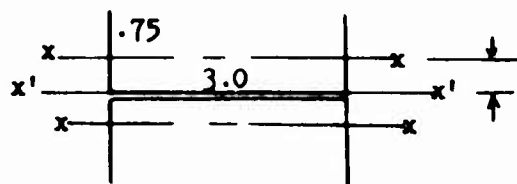

The previously determined $P_B = 1,030$ lb. (Reference 60)

$$M. S. = \frac{1030(5.2)}{3880} - 1 = + .38$$

Riveting: Existing 9 BJ5 rivets
Allowable load = $9(575) = 5,160$ lb. (Reference 60)

$$M. S. = \frac{5,160}{3,880} - 1 = + .34$$

Attachment of stringers to frame

Existing 2 AD5 rivets

Allowable load = $2(575) = 1,150$ lb. (Reference 60)

Applied ultimate load = $3.185(18.5)(10.5) = 620$ lb.

M. S. (ultimate) = $1,150/620 - 1 = + .86$

Frame Bending:

Moment:

$$\begin{aligned} M_{ult} &= 10.5(3602) = 37,800 \text{)} \\ M_{limit} &= 7.0(3602) = 25,200 \text{)} \end{aligned} \text{ (Reference Table 35)}$$

Axial Load:

$$\begin{aligned} P_{ult} &= 10.5(209) = 2,200 \text{ lb.)} \\ P_{limit} &= 7.0(209) = 1,460 \text{ lb.)} \end{aligned} \text{ (Reference 35)}$$

Transformed width of steel

$$= 2.86(.97) = 2.77 \text{ in.}$$

$$I = 2(.97)(.063)^3 + 2(2.86)(.04)^3 + \frac{216}{12} (.063)$$

$$= 1.10 + 2.06 + 1.13$$

$$= 4.26 \text{ in.}^4$$

$$A = 1.94(.04) + 7.94 (.063)$$

$$= .280 + .500 = .580 \text{ in.}^2$$

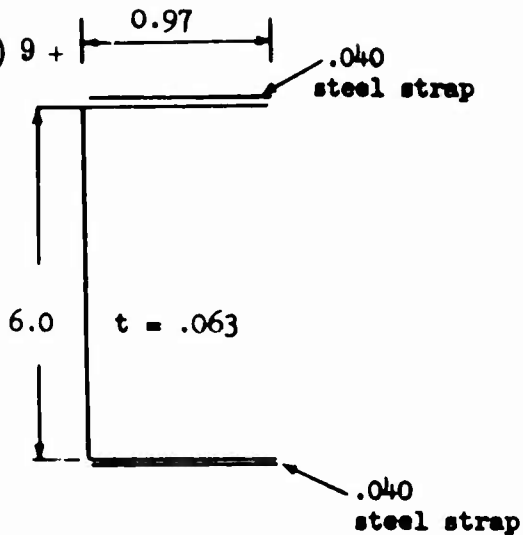

Ultimate Load:

$$f_c = \frac{-2,200}{.580} - \frac{37,800(3)}{4.26} = -3,800 - 26,600$$

$$= 30,400 \text{ psi}$$

$$f_t = -3,800 + 26,600 = 22,800 \text{ psi}$$

$$b/t = .97 / (2.86(.04) + .032) = 6.65$$

$$f_{cu} = 67,500 \text{ psi (Reference 60)}$$

$$\text{M.S. (ultimate)} = 67,500/30,400 - 1 = \text{high}$$

Limit Load:

$$f_c = -30,400/1.5 = -20,200 \text{ psi}$$

$$f_t = 22,800/1.5 = 15,200 \text{ psi}$$

$$f_t \text{ (steel)} = 2.86(15,200) = 43,500 \text{ psi}$$

$$f_a \text{ (steel)} = 21,750 \text{ psi}$$

$$f_a^1 \text{ (steel)} = .90(36,000) = 33,300 \text{ psi (Reference 46)}$$

$$\text{M.S. (limit)} = 32,300/21,750 - 1 = + .48$$

Zone 6

Ultimate pressure = 21.0 psi)
 Limit pressure = 14.0 psi) Left side (Reference Table 34)

Ultimate pressure = 14.5 psi)
 Limit pressure = 13.0 psi) Top (Reference Table 34)

Note that the aluminum skin on the top and the near side has been replaced by steel skin. (Reference page 300)

Critical Stringer: SS-1507-7H Top

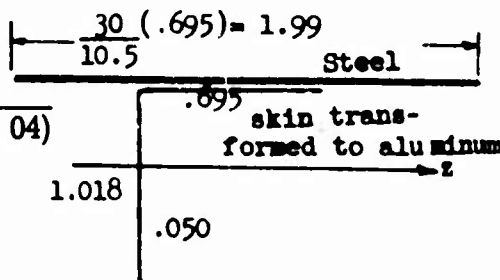

$$\bar{z} = \frac{.0114 + .026}{.695(.05) + 1.243(.05) + 1.99(.04)}$$

$$= \frac{.0114 + .026}{.035 + .062 + .08}$$

$$= \frac{.0374}{.177} = 0.210 \text{ in.}$$

$$I_z = 1.9(.04)(.21)^2 + .695(.05)(.21)^2 + \frac{1}{12} (.05)(1.018)^3 +$$

$$.05(1.018)(.29)^2 + .225(.05)(.81)^2$$

$$= .0033 + .0015 + .0043 + .0043 + .0074$$

$$= .0208 \text{ in.}^4$$

For a unit pressure

$$M_{\text{positive}} = 145 \text{ in. -lb.)}$$

$$M_{\text{negative}} = -259 \text{ in. -lb.) (Reference page 256)$$

Positive Bending:

$$f_c = \frac{145(.21)}{.0208} = -1,450 \text{ psi}$$

$$f_t = \frac{145(.81)}{.0208} = 5,640 \text{ psi}$$

Negative Bending:

$$f_c = \frac{259(.81)}{.0208} = -10,100 \text{ psi}$$

$$f_t = \frac{.259(.21)}{.0208} = 2,590 \text{ psi}$$

In order to reduce the stringer stresses, it is recommended that partial frames be added at Sta. 219 and at 238.5 on the near side.

Thus the stress will become:

Positive Bending (unit pressure):

$$f_c = -1,450/4 = -362 \text{ psi}$$

$$f_t = 5,640/4 = 1,410 \text{ psi}$$

Negative Bending (unit pressure):

$$f_c = -10,100/4 = -2,525 \text{ psi}$$

$$f_t = 2,590/4 = 646 \text{ psi}$$

Ultimate Load:

Positive Bending:

$$f_c = 21(-362) = -7,600 \text{ psi}$$

$$f_t = 21(1,410) = 29,600 \text{ psi}$$

Negative Bending:

$$f_c = 21(2,525) = -54,000 \text{ psi}$$

$$f_t = 21(646) = 13,600 \text{ psi}$$

$$b/t = .225/.05 = 4.5; f_{cu} = 73,000 \text{ (Reference 60)}$$

$$M.S._{ult} = 73,000/54,000 - 1 = +.35$$

Limit Load:

$$f_c = 14(2,525) = -35,300 \text{ psi (Negative bending)}$$

$$f_a = 17,600 \text{ psi}$$

$$f_a' = 32,000 \text{ psi (0.87) (Reference 60)}$$

$$= 27,800 \text{ psi}$$

$$M.S. \text{ Limit} = 7,800/17,600 - 1 = + 0.58$$

The aspect ratio of the skin panels has been reduced, therefore a recheck is required.

$$P_{\text{limit}} = 14.0 \text{ psi}$$

$$a/b = 9.5/6.375 = 1.49$$

$$b/t = 6.375/.040 = 159$$

$$f_{t_{\text{max}}} = 32,000/.80 = 40,000 \text{ psi (Reference 43)}$$

$$f_{t_{\text{min}}} = 40,000/1.49 = 26,800$$

$$f_a^1 = .90(36,000) = 32,300 \text{ psi (Reference 60)}$$

$$f_a'/f_a = 32,300/20,000 = 1.62$$

Partial frame (unit pressure)

$$M = \frac{9.25(33)^2}{8} = 1,250 \text{ in. -lb.}$$

$$M_{\text{ult}} = 21(1,250) = 26,200 \text{ in. -lb.}$$

$$M_{\text{limit}} = 14(1,250) = 17,500 \text{ in. -lb.}$$

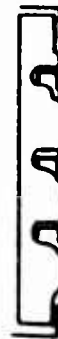

The design of this partial frame is as follows:

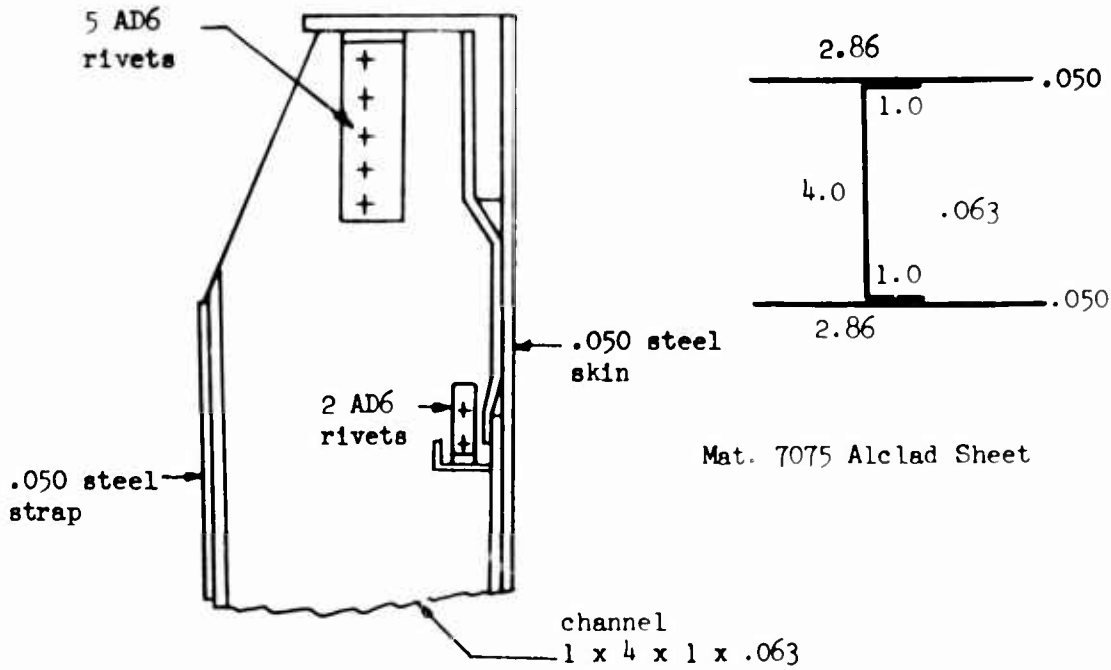

Figure 59. Partial Frame Sta. 219 and 238.5

Load carried by partial frame for unit pressure

$$M = \frac{wl^2}{8} = \frac{9.25(33)^2}{8} = 1,250 \text{ in. -lb.}$$

Ultimate Moment:

$$M = 21(1,250) = 26,200 \text{ in. -lb.}$$

$$f_c = f_t = \frac{26,200(1.5)}{1.69} = 25,200 \text{ psi}$$

$$f_{tu} = 76,000 \text{ psi (Reference 46)}$$

$$b/t = 1.0 / [(2.86)(.05) + .063] = 4.86$$

$$f_{cu} = 72,000 \text{ psi (Reference 60)}$$

$$M. S._{ult} = 72,000/23,200 - 1 = \text{high}$$

Limit Load:

$$f_c = f_t = 23,200/1.5 = 13,500 \text{ psi}$$

$$f_{a(\text{aluminum})} = 7,750 \text{ psi}$$

$$f_{a(\text{steel})} = 2.86(7,750) = 22,200 \text{ psi}$$

$$f'_a (\text{steel}) = .90(36,000) = 32,300 \text{ psi (Reference 60)}$$

$$M. S. (\text{limit}) = 32,300/22,200 - 1 = + .46$$

Attachment of partial frame to longerons - 5 AD6 rivets

$$\text{Load carried by rivets} = 21(9.25) 33/2 = 3,200 \text{ lb.}$$

$$\text{Allowable load} = 5(862) = 4,300 \text{ lb. (Reference 60)}$$

$$M. S. = 4,300/3,200 - 1 = + .35$$

Attachment of stringers to partial frame - 2 AD6 rivets

$$\text{Load carried by rivets} = 21(9.25)(6.375) = 1,240 \text{ lb.}$$

$$\text{Allowable load} = 2(862) = 1,722 \text{ lb. (Reference 60)}$$

$$M. S. = 1,722/1,240 - 1 = + .39$$

Frame at Station 229:

Axial Tie:

$$\begin{array}{l} P_{ult} = 21(370) = 7,750 \text{ lb. }) \\ P_{limit} = 14(370) = 5,200 \text{ lb. }) \end{array} \quad (\text{Reference Table 35})$$

Buckling:

$$I = 2 \left[\frac{1}{12} (.063)(2)^3 \right]$$

$$= .084 \text{ in.}^4$$

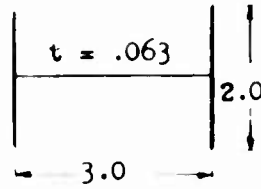

$$P_B = \frac{\pi^2 EI}{L^2} = \frac{(3.14)^2 (10.5 \times 10^6) (.084)}{26^2} = 12,900 \text{ lb.}$$

$$\text{M. S.} = 12,900/7,750 - 1 = + .67$$

Local crippling - one channel only

$$\text{Leg } b/t = 1/.063 = 15.9 \quad f_{cu} = 26,000 \text{ (Reference 60)}$$

$$A = 2(.063) = .126$$

$$\text{Web } b/t = 3.0/.063 = 47.5 \quad f_{cu} = 25,000 \text{ (Reference 60)}$$

$$A = 3.0 (.063) = .189$$

$$P_{cu} = .126(26,000) + .189(25,000)$$

$$= 3,270 + 4,750 = 8,000 \text{ lb.}$$

$$\text{M. S.} = 8,000/7,750 - 1 = + .03$$

Frame Bending:

$$\begin{aligned} M_{ult} &= 21(3,602) = 75,500 \text{ in. -lb. } \\ M_{limit} &= 14(3,602) = 50,500 \text{ in. -lb. } \end{aligned} \quad \text{(Reference Table 35)}$$

$$\begin{aligned} P_{ult} &= 21(209) = 4,400 \text{ lb. } \\ P_{limit} &= 14(209) = 2,930 \text{ lb. } \end{aligned} \quad \text{(Reference Table 35)}$$

Width of transformed steel

$$= 2.86(.97) = 2.77 \text{ in.}$$

$$I = 2(2.77)(.125)^3 + 2(.97)(.063)^3$$

$$+ \frac{9^3}{12} (.063)$$

$$= 8.651 \text{ in.}^4$$

$$A = 0.92(.125)^2 + 2(.063)(.97) + 6(.063)$$

$$= .240 + .121 + .378$$

$$= .739 \text{ in.}^2$$

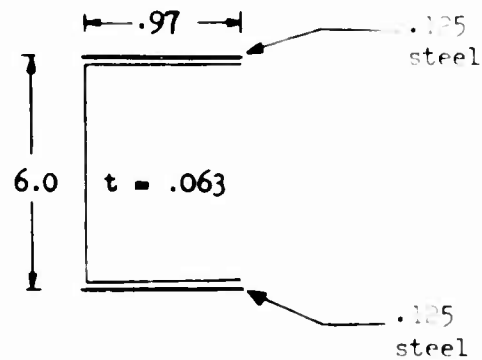

Considering limit load only,

$$f_t = \frac{-2,930}{.739} + \frac{50,500(3)}{8.651} = -4,000 + 17,512$$

$$= 13,512 \text{ psi}$$

$$f_t (\text{steel}) = 13,512(2.86) = 38,600 \text{ psi}$$

$$f_a = 19,300 \text{ psi}$$

Frame at Sta. 453.5:

$$\bar{z} = \frac{.103(6) + 5(.063)(3.0)}{6(.063) + .103}$$

$$= \frac{.618 + 1.134}{.441 + .103}$$

$$= \frac{1.752}{.544} = 3.2 \text{ in.}$$

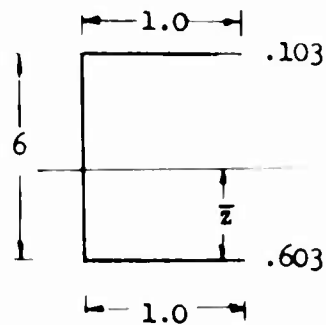

$$I = 1(.103)(2.8)^2 + .063(3.2)^2 + \frac{216}{12} (.063) + 6 (.063)(.2)^2$$

$$= .807 + .645 + 1.134 + .01$$

$$= 2.596 \text{ in.}^4$$

Bending Moment:

$$\begin{aligned} M_{ult} &= 5.44(3,602) = 19,000 \text{ in. -lb. } \\ M_{limit} &= 3.62(3,602) = 12,650 \text{ in. -lb. } \end{aligned} \quad \left. \vphantom{\begin{aligned} M_{ult} \\ M_{limit} \end{aligned}} \right\} \text{ (Reference Table 35)}$$

Axial Load:

$$\begin{aligned} P_{ult} &= 5.44(-209) = -1,140 \text{ lb. } \\ P_{limit} &= 3.62(-209) = -756 \text{ lb. } \end{aligned} \quad \left. \vphantom{\begin{aligned} P_{ult} \\ P_{limit} \end{aligned}} \right\} \text{ (Reference Table 35)}$$

Limit Load:

$$\begin{aligned} f_c &= \frac{-756}{.544} - \frac{12,650(3.2)}{2.596} = 1,390 - 13,129 \\ &= 14,519 \text{ psi} \end{aligned}$$

$$\begin{aligned} f_t &= \frac{-756}{.544} + \frac{12,650(2.8)}{2.596} = -1,390 + 13,640 \\ &= 12,250 \text{ psi} \end{aligned}$$

$$f_a = 12,250/2 = 6,125 \text{ psi, } K_T = 3.0$$

$$f_a' = .87(17,500) = 15,200 \text{ psi (Reference 60)}$$

$$\text{M. S. limit} = 15,200/6,125 - 1 = + \text{ high}$$

Ultimate Load:

$$f_c = 1.5(14,519) = -21,779 \text{ psi}$$

$$f_a' = .90(36,000) = 32,300 \text{ psi (Reference 60)}$$

$$\text{M. S. (limit)} = 32,300/19,300 - 1 = + .67$$

Zone 6 - Intercostals, Left Side:

Limit Load:

$$M = 14(895) = 12,500 \text{ in. -lb. (Reference Page 258)}$$

Transformed width of steel

$$= 2.86(.73) = 2.1 \text{ in.}$$

$$\bar{z} = \frac{1.16(.05)(.508) + 3.84(.032)2.43 + 1.46(.032)}{2.1(.05) + 2(.73)(.05) + 1.16(.05) + 3.84(.032)}$$

$$= \frac{.444}{.358} = 1.25 \text{ in.}$$

$$I = 2.1(.05)(1.25)^2 + .75(.05)(1.25)^2 + .73(.032)(3.75)^2$$

$$+ \frac{1}{12}(.05)(1.16)^2 + 1.16(.05)(.44)^2 + \frac{1}{12}(.032)(3.84)^3$$

$$+ 3.84(.032)(1.9)^2$$

$$= 1.164 \text{ in.}^4$$

$$f_t = \frac{12,500(3.75)}{1.164} = 40,500 \text{ psi}$$

$$f_a = 20,250 \text{ psi}$$

$$f_a' = .87(34,000) = 29,600 \text{ psi (Reference 60)}$$

$$M.S. = 29,600/20,250 - 1 = +.46 \text{ (limit)}$$

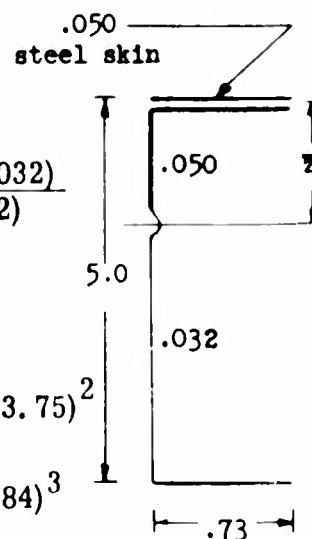

Zone 7 Intercostals - Left Side

Replace intercostals on left side of zone 7 by SS 1506-F7.
See analysis above.

Zone 8 - Frame Sta. 453.5

Avg. pressures acting on frame 453.5

$$\left. \begin{array}{l} p_{ult} = 5.44 \text{ psi} \\ p_{limit} = 3.62 \text{ psi} \end{array} \right\} \text{ (Reference Table 34)}$$

Stringers: SS-1507-9H

$$\begin{aligned} \bar{z} &= \frac{.225(.063) + 1.0(.063)(.5)}{.695(.103) + 1.225(.063)} \\ &= \frac{.0462}{.149} = 0.31 \text{ in.} \end{aligned}$$

$$I = .695(.103)(.31)^2 + .225(.063)(.69)^2 + .225$$

$$\frac{1}{12}(.063) + (.063)(.19)^2$$

$$= .0212 \text{ in.}^4$$

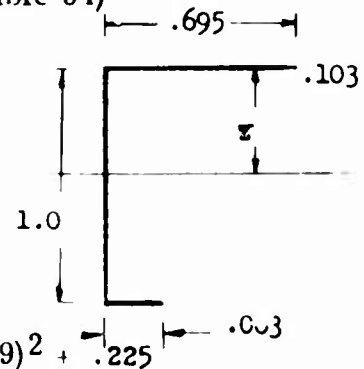

The stringer is critical at sta. 453.5

$$M_{limit} = 5.0 \frac{1}{8} (6.375)(18)^2 = 5(258) \text{ in. -lb.}$$

$$f_c = \frac{258(5)(.69)}{.0212} = 42,000 \text{ psi (} K_T = 1.0 \text{)}$$

$$f_t = \frac{258(5)(.31)}{.0212} = 18,900 \text{ psi (} K_T = 3.0 \text{)}$$

$$f_a = 9,450 \text{ psi } K_T = 3.0$$

$$f_a' = .87(17,500) = 15,200 \text{ psi (Reference 60)}$$

$$M.S. = 15,200/9,450 - 1 = + .61 \text{ (limit)}$$

Ultimate Load:

$$f_c = 1.5(42,000) = 63,000 \text{ psi}$$

$$b/t = .225/.063 = 3.57$$

$$f_{cu} = 73,000 \text{ psi (Reference 60)}$$

$$M. S. = 73,000/63,000 - 1 = + .16 \text{ (ultimate)}$$

$$f_t = 1 (12,250) = 12,370$$

$$b/t = 1.0/.063 = 15.9$$

$$f_{cu} = 26,000 \text{ psi (Reference 60)}$$

$$M. S. \text{ ultimate} = 26,000/21,779 - 1 = + .19$$

Frame Axial Tie:

.063

$$\bar{z} = \frac{1(.063)(.5)^2}{8(.063)} = .125 \text{ in.}$$

$$I' = 6(.063)(.125)^2 + \frac{2}{12} (.063)$$

$$+ 2(.063)(.375)^2$$

$$= .0059 + .0105 + .0177$$

$$= .0341 \text{ in.}^4$$

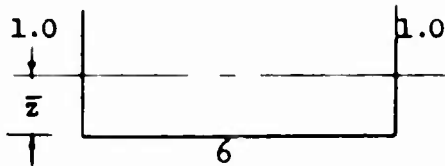

The Existing Moment of Inertia Before Modification:

$$I = .00648$$

$$P_B = 503 \text{ lb.}$$

$$P_B' = \frac{I'}{I} P_B = \frac{.0341}{.00648} (503) = 2,645 \text{ lb.}$$

$$\text{Axial load in tie} = 5.44(370) = 2,013 \text{ lb. (Reference Table 35)}$$

$$M. S. = 2,645/2,013 - 1 = + .31$$

The axial tie is made integral with the frame.

Zone 9 - Frame at Sta. 510

$$\bar{z} = \frac{.063(4.5) + 4.5(.063)2.25}{5.5(.063) + .103}$$

$$= \frac{.284 + .638}{.347 + .103}$$

$$= \frac{.922}{.450} = 2.0 \text{ in.}$$

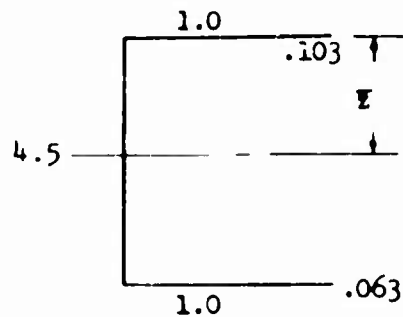

$$\begin{aligned}
I &= .103(2.0)^2 + .063(2.5)^2 \\
&\quad + \frac{91.1}{12} (.063) \\
&= .412 + .394 + .478 \\
&= 1.254 \text{ in.}^4
\end{aligned}$$

Moment:

$$\begin{aligned}
M_{ult} &= 3.38(3,602) = 12,200 \\
M_{limit} &= 8,150
\end{aligned}
\left. \vphantom{\begin{aligned} M_{ult} \\ M_{limit} \end{aligned}} \right\} \text{(Reference Table 35)}$$

Axial Load:

$$\begin{aligned}
P_{ult} &= 3.38(209) = 705 \text{ lb.} \\
P_{limit} &= 470 \text{ lb.}
\end{aligned}
\left. \vphantom{\begin{aligned} P_{ult} \\ P_{limit} \end{aligned}} \right\} \text{(Reference Table 35)}$$

Limit Load:

$$f_c = \frac{470}{.450} - \frac{8,150(2.5)}{1.284} = -1,044 - 15,870 = -16,914 \text{ psi}$$

$$f_t = \frac{-470}{.418} + \frac{8,150(2.0)}{1.284} = -1,044 + 12,695 = 11,651 \text{ psi}$$

$$f_a = 11,651/2 = 5,830 \text{ psi } K_T = 3.0$$

$$f'_a = .87 (17,500) = 15,200 \text{ psi (Reference 60)}$$

$$\text{M.S.} = 15,200/5,830 - 1 = \text{High (limit)}$$

Ultimate Load:

$$f_c = 1.5(16,914) = 25,300 \text{ psi}$$

$$b/t = 1.0/.063 = 15.9$$

$$f_{cu} = 26,000 \text{ psi (Reference 60)}$$

$$\text{M.S.} = 26,000/25,300 - 1 = + .03 \text{ (ultimate)}$$

The axial tie should be integral with the frame.

Zone 11-12 Stringers - Upper

Existing stringers 1.75 x 1.25 x .125 extrusions

$$P_{ult} = 28.5 \text{ psi}$$

$$P_{limit} = 19.0 \text{ psi}$$

Use Extruded Channels: Reynolds Die #10067.

$$\begin{aligned} \bar{z} &= \frac{1.055(1.25)}{1.055 + 2.86(1.75)(.05)} \\ &= 1.05 \text{ in.} \end{aligned}$$

$$\begin{aligned} I &= 1.03 + 1.055(.20)^2 \\ &\quad + 1.75(.05)(1.05)^2 \\ &= 1.30 \text{ in.}^4 \end{aligned}$$

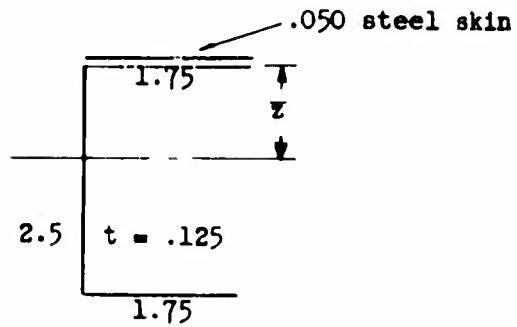

Limit Load:

$$M = wj^2(\text{Sec. } 1/2 \text{ U}-1) \text{ (Reference 44)}$$

$$j = \left[\frac{EI}{P} \right]^{1/2}$$

$$P = 19(151) = 2,870 \text{ lb. (Reference page 267)}$$

$$\begin{aligned} j &= \left[\frac{10.5 \times 10^6 \times 1.30}{2,870} \right]^{1/2} \\ &= 69.0 \end{aligned}$$

$$U = \frac{1}{j} = \frac{33.5}{69} = .485 \text{ radian}$$

$$\text{Sec. } \frac{1}{2} \text{ U} = 1.031$$

$$\begin{aligned} M_{limit} &= \left[19(10.75)(89)^2 \right] .031 \\ &= 30,145 \text{ in. -lb.} \end{aligned}$$

$$f_t = \frac{30,145(1.45) - 2,870}{1.30} - \frac{2,870}{1.15}$$

$$= 31,128 \text{ psi}$$

$$f_a = 15,564 \text{ psi}$$

$$f_a' = .87(32,000) = 27,800 \text{ psi (Reference 60)}$$

$$\text{M. S.} = 27,800/15,564 - 1 = + .78$$

Ultimate Load:

$$f_c = 1.5 \left[\frac{30145(1.05)}{1.30} - \frac{2,870}{1.15} \right]$$

$$= 40,000 \text{ psi}$$

$$b/t = 1.75/[2.86(.05) + .063] = 10.4$$

$$f_{cu} = 50,000 \text{ psi (Reference 60)}$$

$$\text{M. S.} = 50,000/40,000 - 1 = + .25$$

Zone 11-12 - Lower

$$P_{ult} = 16.5 \text{ psi}$$

$$P_{limit} = 11.0 \text{ psi}$$

$$\text{Uniform load for a unit pressure} = 10.75 \text{ lb./in.}$$

$$\text{Simply supported span} = 33.5 \text{ in.}$$

$$\text{Maximum moment for unit pressure} = 1,480 \text{ in.-lb.}$$

(Reference
page 267)

$$\text{Axial load for a unit pressure} = 151 \text{ lb.}$$

$$M_{limit} = 11(1,480) = 16,200 \text{ in.-lb.}$$

$$P_{limit} = 11(151) = 1,660 \text{ lb.}$$

Use Reynolds Die #10611 extruded channel.

$$\bar{z} = \frac{.625(1.25)}{.602 + 3.93(.05)}$$

$$= \frac{.78}{.798} = .98 \text{ in.}$$

$$I = 3.93(.05)(.98)^2 + .602 + .625(.27)^2$$

$$= .835 \text{ in.}^4$$

$$A = .625 + .070 = .695 \text{ in.}^2$$

$$f_t = \frac{-1,660}{.695} + \frac{16,200(1.52)}{.835} = 27,100 \text{ psi}$$

$$f_t \text{ (ult.)} = 1.5(27,100) = 40,600 \text{ psi}$$

$$\text{M.S. (ult.)} = 76,000/40,600 - 1 = +.87$$

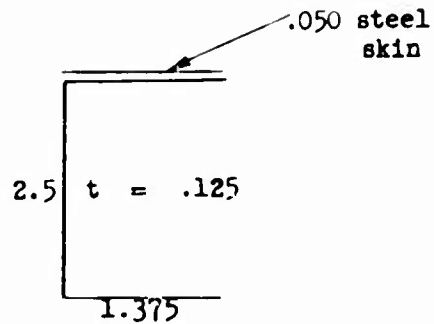

Zone 10 - Upper

Maximum moment for a unit pressure = 885 in.-lb.
(Reference page 269)

$$P_{\text{limit}} = 8.5 \text{ psi (Reference Table 34)}$$

$$M_{\text{limit}} = 8.5(885) = 7,500 \text{ in.-lb.}$$

Use Reynolds Die #6678 extruded channel

$$\bar{z} = \frac{.469(1.0)}{.469 + .063}$$

$$= .88 \text{ in.}$$

$$I = .388 \text{ in.}^4$$

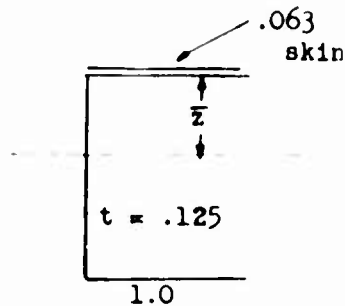

Limit Load:

$$f_t = 7,500(1.12)/.388 = 21,600 \text{ psi}$$

$$f_a = 10,800 \text{ psi}$$

$$f_a' = .87(30,000) = 26,000 \text{ psi (Reference 60)}$$

$$\text{M.S.} = 26,000/10,800 - 1 = + \text{ High}$$

Ultimate Load:

$$f_c = 1.5(7,500)(.88)/.388 = 25,800 \text{ psi}$$

$$b/t = 1.0/.157 = 6.4$$

$$f_{cu} = 72,000 \text{ psi (Reference 60)}$$

$$\text{M.S.} = 72,000/25,800 - 1 = \text{High}$$

Zone 10 - Lower

Existing angle 1.5 x 1.25 x .125 extruded angles

M_{max} for unit pressure = 885 in.-lb. (Reference page 269)

$P_{\text{limit}} = 6.0 \text{ psi}$ (Reference Table 34)

Use two 1.5 x 1.25 x .125 extruded angles back to back.

$$I = .140 + .024 = .164 \text{ in.}^4$$

$$A = .66 \text{ in.}^2$$

$$\bar{z} = .44 \text{ in.}$$

$$M_{\text{limit}} = 6(885) = 5,300 \text{ in.-lb.}$$

$$f_t = \frac{5,300(1.06)}{.164} = 34,200 \text{ psi}$$

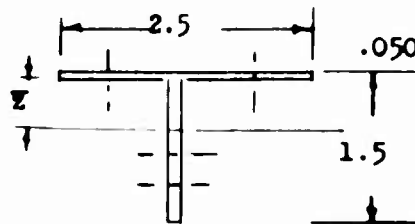

$$f_a = 17,100 \text{ psi}$$

$$f_a' = .87(30,000) = 26,000 \text{ psi (Reference 60)}$$

$$\text{M.S.} = 26,000/17,100 - 1 = + .52 \text{ Limit}$$

Zone 6 - Longerons

Upper left, upper right, lower left

Reinforce in the following manner:

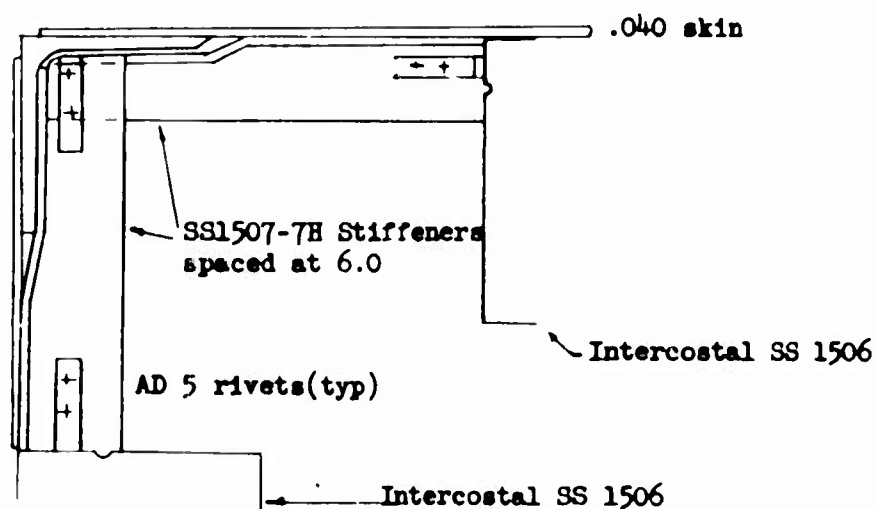

Figure 60. (U) Fuselage Longeron Reinforcement

The beam is considered as being fixed ended with a span of 18.0 inches.

$$\bar{z} = y = \frac{6.375(.38)}{2.2} = 1.1 \text{ in.}$$

$$I = 1.44 (1.56)^2 + 2(.38)(7.47)^2$$

$$= 45.9 \text{ in.}^4$$

$$\text{Skin stress} = 40,000 \text{ psi}$$

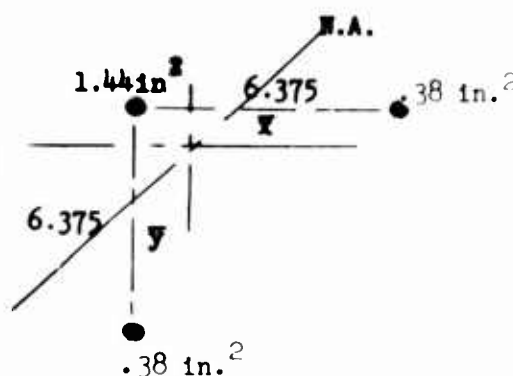

Uniform load = .04(40,000) = 1,600 lb./in.

Resultant M = $\frac{43,000}{.707}$ = 61,000 in.-lb.

$f_c = \frac{61,000(7.47)}{45.9}$ = 10,000 psi

Compression in intercostal is critical.

b/t = .73/.072 = 23

$f_{cu} = 17,500$ psi (Reference 60)

M. S. $_{ult} = \frac{17,500}{10,000} - 1 = + .75$

Attachments:

Sta. 173-210 stringers to frames and bulkheads

Load = 18(6.375)(10.5) = 1,210 lb.

2 BJ5 rivets = 2(594) = 1,188 lb. (Reference 60)

Use BJ6 rivets

M. S. = 2(862)/1,210 - 1 = + .43

Sta. 210-248 stringer attachment, left side

Load = 9(21)(6.375) = 1,210 lb.

Use BJ6 rivets

M. S. = 2(862)/1,210 - 1 = + .43

(U) Fuselage and Landing Gear Support Structure Skin

Zone 6 - Left Side

Limit Load:

$$f_{t(\max)} = 37,500 \text{ psi (Reference 43)}$$

$$f_a = \frac{37,500}{2}$$
$$= 18,750 \text{ psi}$$

SAE 4130 steel - heat treated to 180 ksi

$$K_T = 3.0 \quad N = 2.67 \times 10^4$$

$$f_a' = .90 (36,000)$$
$$= 32,300 \text{ psi (Reference 60)}$$

$$\text{M. S.} = \frac{32,300}{18,750} - 1$$
$$= + .73$$

Zone 6 - Top

Limit Load:

$$f_{t(\max)} = 42,500 \text{ psi (Reference 43)}$$

$$f_a = 21,250 \text{ psi}$$

SAE 4130 steel - heat treated to 180 ksi

$$K_T = 3.0 \quad N = 2.67 \times 10^4$$

$$f_a' = .90(36,000)$$
$$= 32,300 \text{ psi (Reference 60)}$$

$$\begin{aligned} \text{M. S.} &= \frac{32,300}{21,250} - 1 \\ &= + .52 \end{aligned}$$

Zone 11 - Upper

Limit Load:

$$\begin{aligned} f_{t(\max)} &= \frac{39,000}{.80} \quad (\text{Reference 43}) \\ &= 49,000 \text{ psi} \end{aligned}$$

$$f_a = 24,500 \text{ psi}$$

Steel SAE 4130 - heat treated to 180 ksi

$$K_T = 3.0 \quad N = 2.67 \times 10^4$$

$$\begin{aligned} f_a' &= .90(36,000) \quad (\text{Reference 60}) \\ &= 32,300 \text{ psi} \end{aligned}$$

$$\begin{aligned} \text{M. S.} &= \frac{32,300}{24,500} - 1 \\ &= + .37 \end{aligned}$$

Zone 11 - Lower

Limit Load:

$$\begin{aligned} f_{t(\max)} &= \frac{26,000}{.80} \quad (\text{Reference 43}) \\ &= 32,500 \text{ psi} \end{aligned}$$

$$f_a = 16,250 \text{ psi}$$

SAE 4130 steel - heat treated to 125 ksi

$$\begin{aligned}
 f_a' &= .90(26,000) \quad (\text{Reference 60}) \\
 &= 23,400 \text{ psi} \\
 \text{M. S.} &= \frac{23,400}{16,250} - 1 \\
 &= + .44
 \end{aligned}$$

(U) Electronic and Gun Crew Pod Structural Analysis

Floor Load (Frame, Skins, and Longerons)

Five-man gun crew	1,000 lb.
Equipment	600 lb.
	1,600 lb.

Load factors for symmetrical dive and pullout condition

$$N_z = 2.5$$

Reference 56

$$\alpha_y = 1.863$$

Distance from C. G. to gun crew pod = 12 ft.

$$\begin{aligned}
 \text{Vertical load factor} &= 2.5 + \frac{1.863(12)}{32.2} = 2.5 + .695 \\
 &= 3.195 \text{ limit}
 \end{aligned}$$

$$\begin{aligned}
 \text{Ultimate vertical load factor} &= 1.5(3.195) \\
 &= 4.8
 \end{aligned}$$

$$\text{Ultimate floor load} = 4.8(1,600) = 7,780 \text{ lb.}$$

$$\begin{aligned}
 \text{Floor load per unit area} &= \frac{7,780}{102(88)} \times 144 = 125 \text{ lb./ft.}^2 \\
 \text{for frames, skins, longerons} &
 \end{aligned}$$

This floor load is used in the design of the overall structure; however, the floor itself should be serviceable and therefore should be designed for a static load of 200 psf.

$$\begin{aligned} \text{Ultimate floor load for floor design} &= 200 \times 4.8 \\ &= 960 \text{ lb. /ft.}^2 \end{aligned}$$

Bending which produces compression on the inner fiber is positive.

The following equations must be solved in order to determine the redundants H_0 and M_0 .

$$(1) \int \frac{Mm_m ds}{I} + M_0 \int \frac{m_m^2 ds}{I} + H_0 \int \frac{m_m m_h ds}{I} = 0$$

$$(2) \int \frac{Mm_h ds}{I} + M_0 \int \frac{m_h m_m ds}{I} + H_0 \int \frac{m_h^2 ds}{I} = 0$$

$$\begin{aligned} \int \frac{Mm_m ds}{I} &= 2 \frac{(1930)(79)(-1)}{2} + \frac{1930(88)(-1)}{4} + \frac{2}{3} \frac{(21200)(88)(-1)}{4} \\ &= -505930 \end{aligned}$$

$$\begin{aligned} \int \frac{m_m^2 ds}{I} &= (-1)(88)(-1) + (-1)(79)(-1)2 + \frac{1}{4} (-1)(88)(-1) \\ &= 268 \end{aligned}$$

$$\begin{aligned} \int \frac{m_m m_h ds}{I} &= (-1)(79)(-39.5)2 + \frac{1}{4} (-1)(88)(-79) \\ &= 7979 \end{aligned}$$

$$\begin{aligned} \int \frac{Mm_h ds}{I} &= 2(1930)(79) \frac{1}{2} \frac{2}{3} (-79) + 1930(88)(-79) \frac{1}{4} + \\ &\quad \frac{2}{3} \frac{1}{4} (21200)(88)(-79) \\ &= -36 \times 10^6 \end{aligned}$$

Frame EFGH (Reference Figure 63)

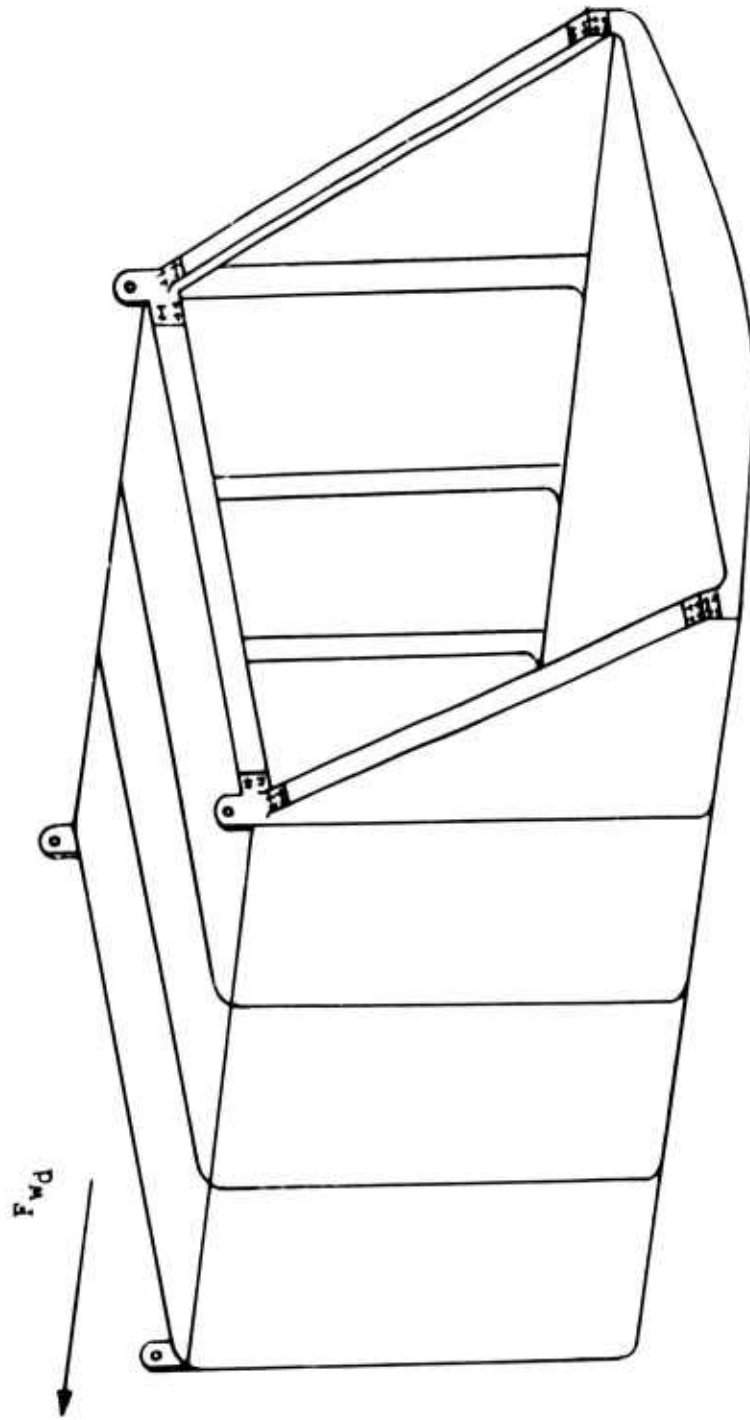

Figure 61. (U) Electronic Gear and Gun Crew Pod

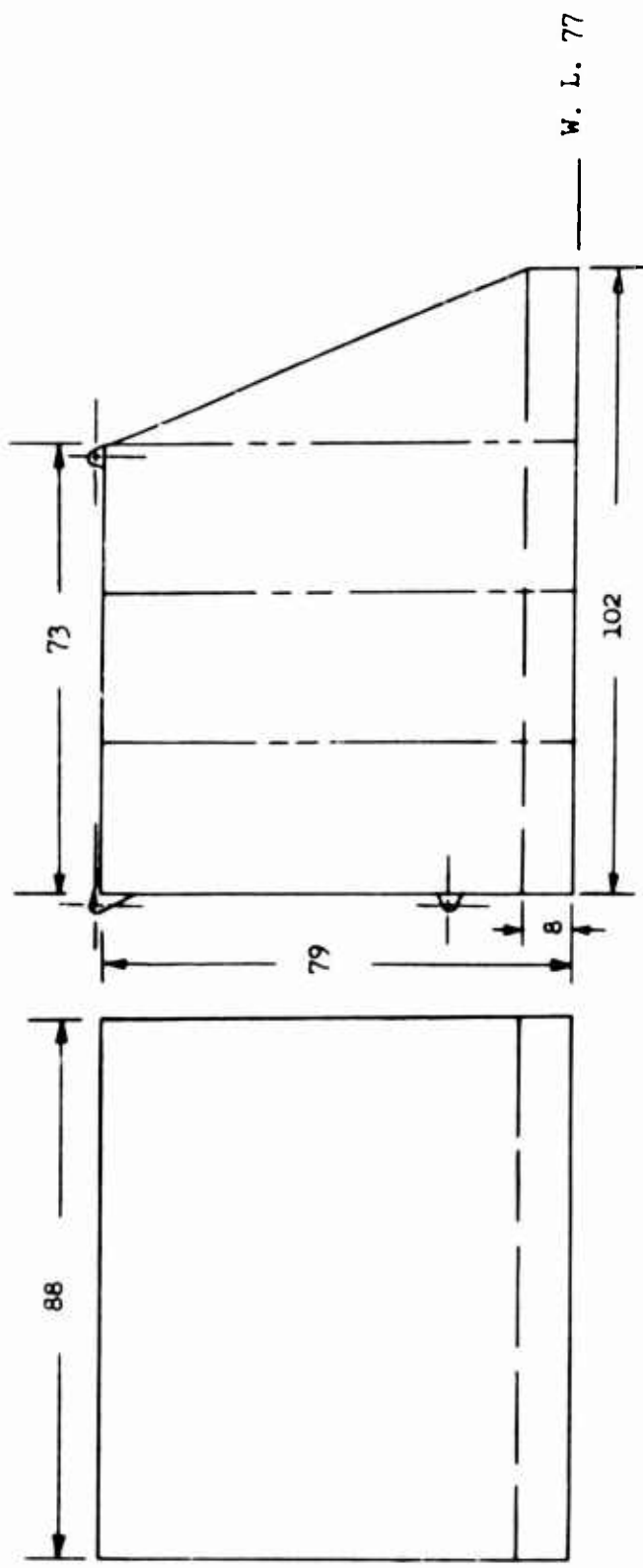

Figure 62. (U) Electronic Gear and Gun Crew Pod

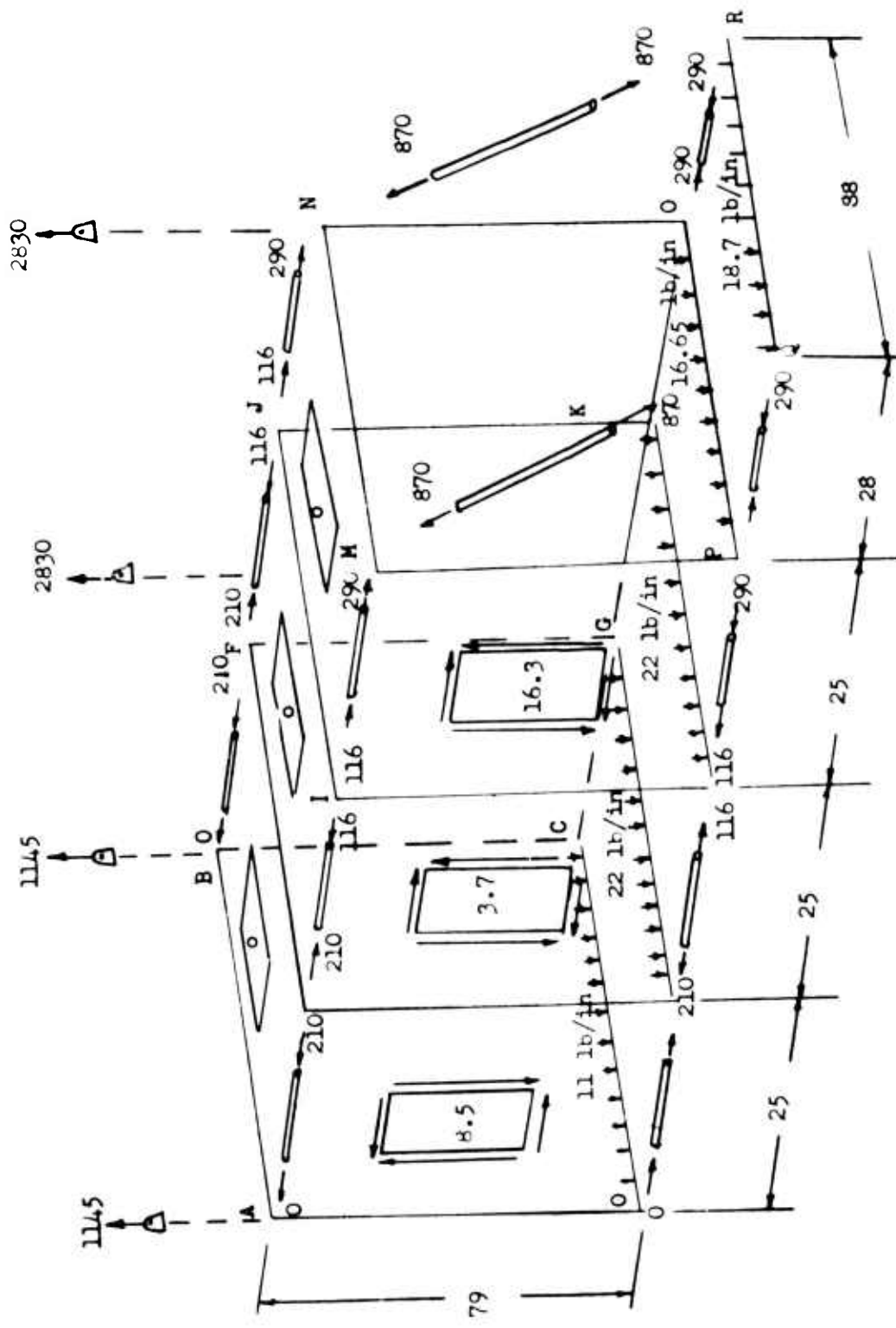

Figure 63. (U) Equilibrium of Electronic Gear and Gun Crew Pod
For Ultimate Load of 125 lb./ft².

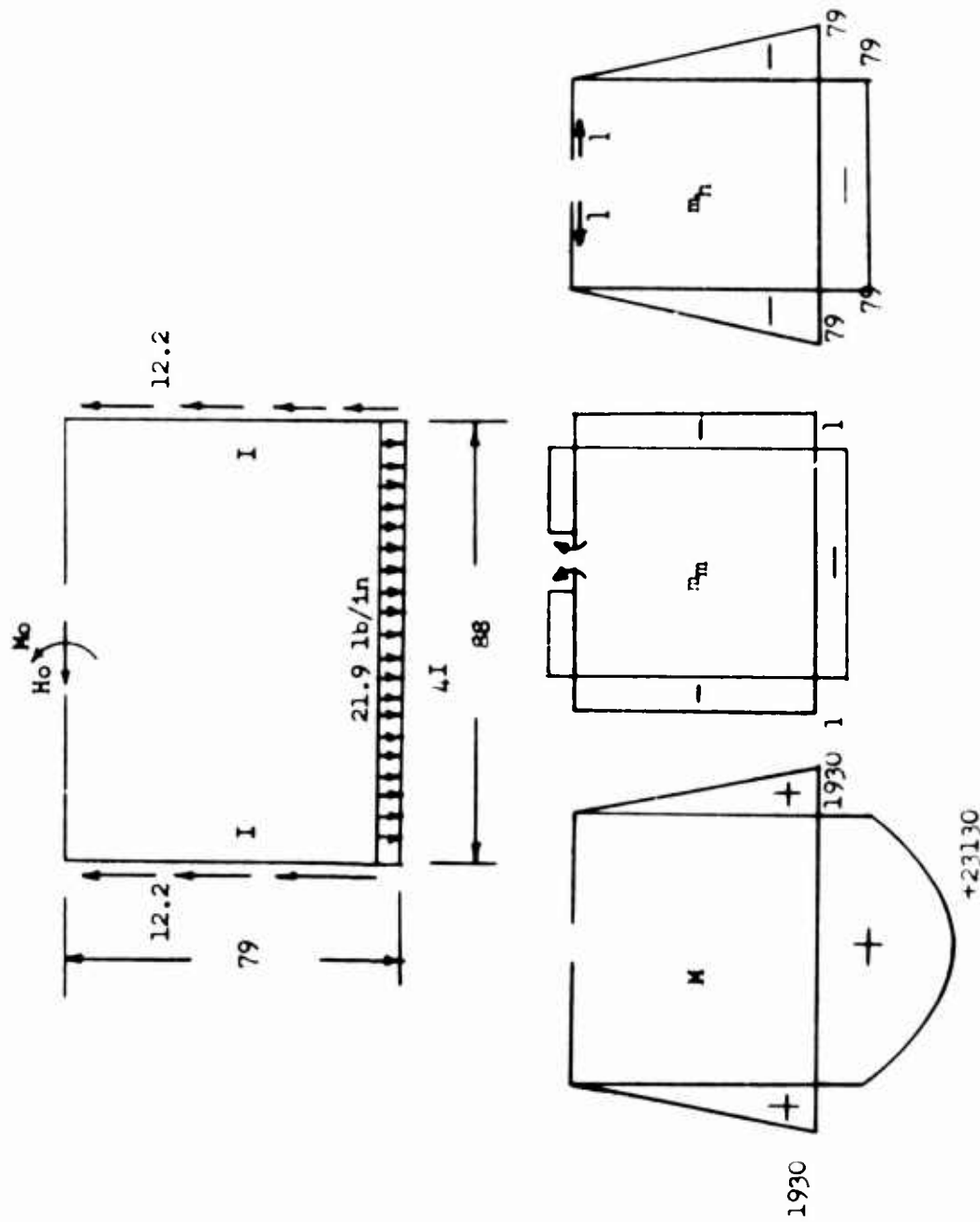

Figure 64. (U) Gun Crew Pod Frame Bending Analysis

$$\int \frac{m_h^2 ds}{I} = \frac{21}{2} (-79)(79) \frac{2}{3} (-79) + (-79)(88)(-79)$$

$$= 878108$$

$$(1) -506 + .27 M_o + 8 H_o = 0$$

$$-36000 + 8 M_o + 878 H_o = 0$$

$$M_o = 903 \text{ in. -lb.}$$

$$H_o = 33 \text{ lb.}$$

$$M_t = M + M_o m_m + H_o m_h$$

Bending at Section A-A (Reference Figure 65)

$$M = 19,620 \text{ in. - lb.}$$

$$I = \left[1.25(16)(2) + \frac{512}{12} \right] (.063)$$

$$= 5.22$$

$$f_c = \frac{19,620(4)}{5.22} = 15,034 \text{ psi}$$

$$b/t = 1.22/ (.063 + .016) = 15.5$$

$$f_{cu} = 22,500 \text{ psi (Reference 60)}$$

$$\text{M.S.} = 22,500/15,034 - 1 = +.50 \text{ Ultimate}$$

Shear at Section C-C (Reference Figure 65)

$$v = 965 \text{ lb.}$$

$$q = 965/3 = 322 \text{ lb./in.}$$

$$f_s = 322/.063 = 5,100 \text{ psi}$$

$$b/t = 3.0/.063 = 47.5$$

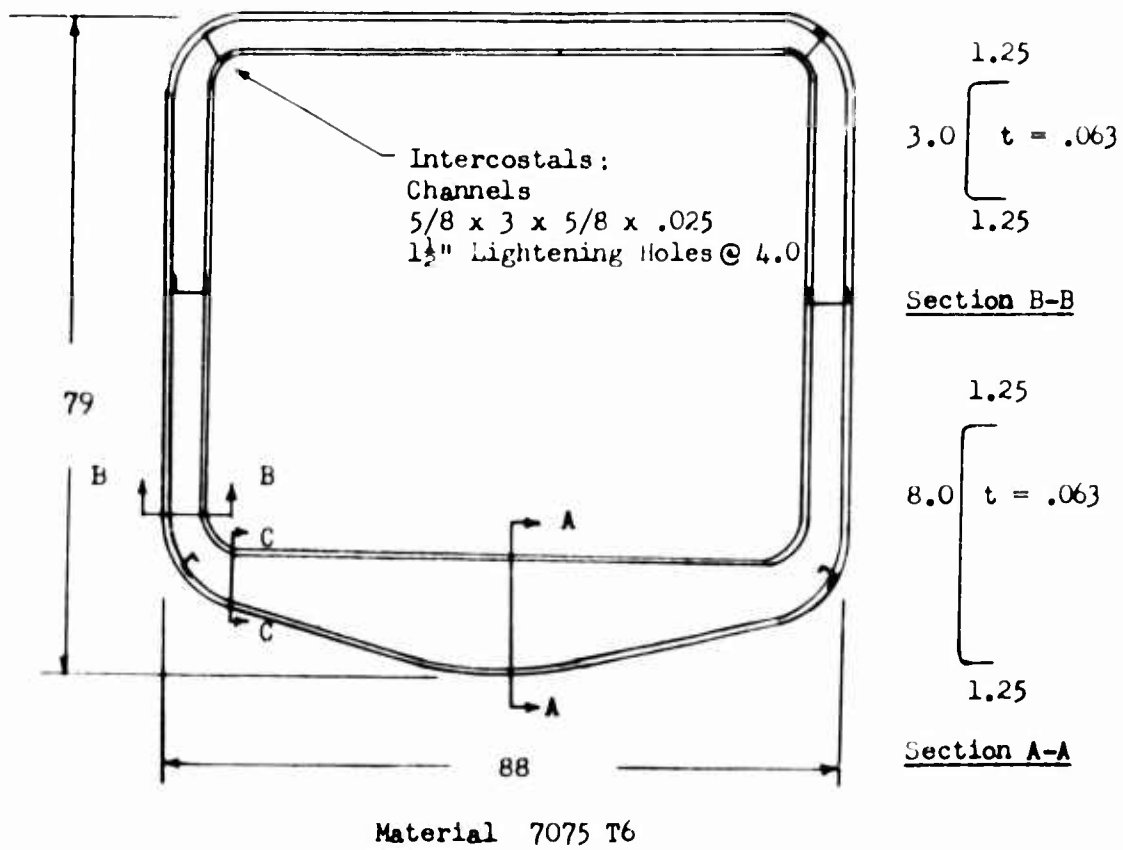
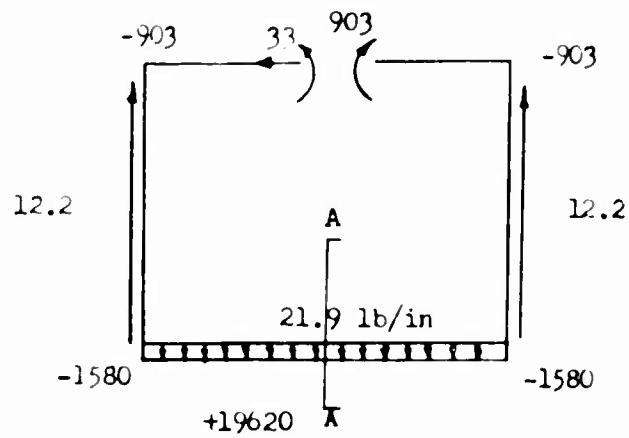

Figure 65. (U) Electronic Gear And Gun Crew Pod Typical Frame

$$f_{scr} = 18,000 \text{ psi} \quad (\text{Reference 60})$$

The web of the frame is shear resistant.

Analysis of Member Q - R
(Reference Figure 67)

$$w = 18.7 \text{ lb./in.}$$

Simple support at Q and R

$$M = 18.7 (88)^2$$

$$= 18,000 \text{ in.-lb.}$$

Bending at Section B-B

$$I = 5.22 \text{ in.}^4$$

$$f_c = \frac{18,000(4)}{5.22} = 13,800 \text{ psi}$$

$$b/t = 1.22 (.063 + .016) = 15.5$$

$$f_{cu} = 22,500 \text{ psi} \quad (\text{Reference 60})$$

$$\text{M. S.} = 22,500/13,800 - 1 = +.63 \text{ Ultimate}$$

Shear at Section A-A

$$v = 820 \text{ lb.}$$

$$f_s = \frac{820}{3(.063)} = 4,330 \text{ psi}$$

$$b/t = 3/.063 = 47.5$$

$$f_{scr} = 18,000 \text{ psi} \quad (\text{Reference 60})$$

The web is shear resistant.

Member M-Q: (Reference 67)

Ultimate tension load - 870 lb.

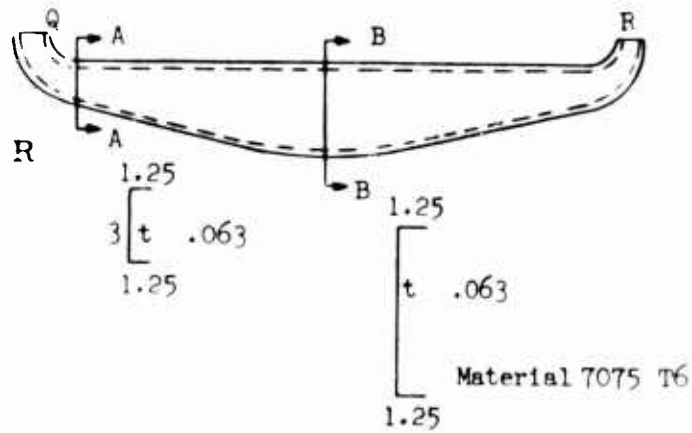

Figure 66. (U) Gun Crew Pod Beam

Use a channel 1.25 x 3 x 1.25 x .063

$$A = [5.5 - 2(.156)] .063$$

$$= .326 \text{ in.}^2 \text{ (Reference 46)}$$



$$f_t = 870 / .326 = 2,670 \text{ psi}$$

$$f_{tu} = 76,000 \text{ psi (Reference 46)}$$

M. S. = High

Splice of Member MQ to QR:

Use .063 splice plate

3 inches wide 7075 T6

$$\text{Net Area} = (3 - .312) (.063)$$

$$= .169$$

$$f_t = 870 / .169 = 5,150 \text{ psi}$$

$$f_{tu} = 76,000 \text{ psi (Reference 46)}$$

M. S. = High

$$\text{Allowable Rivet Load} = 4(596) = 2,390 \text{ lb. (Reference 60)}$$

$$\text{M. S.} = 2,390 / 870 - 1 = \text{High}$$

Skin:

Use .032 7075 T6 Skin

Use SS1507-2H Stiffeners at 8.0 inches

$$q = 16.3 \text{ lb./in.}$$

$$f_s = 16.3 / .032 = 510 \text{ psi}$$

$$b/t = 8 / .032 = 250$$

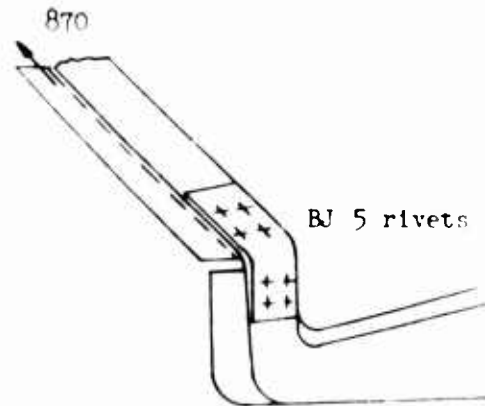

$$f_{scr} = 950 \text{ psi (Reference 60)}$$

The skin is shear resistant.

Longeron at Bottom:

Stringer SS 1507 -3H

$$A = 0.069$$

$$f_c = 290 / .10 = 2,900 \text{ psi}$$

$$b/t = .696 / .056 = 12.4$$

$$f_{cu} = 35,000 \text{ psi (Reference 60)}$$

M. S. = High

Floor:

The floor is designed for an ultimate load of 970 lb./ft.²
Use .032 skin with stiffeners (SS 1507 - 3H) at 2 inches.

$$w = 6.7 \text{ psi (2)}$$

$$13.4 \text{ lb./in.}$$

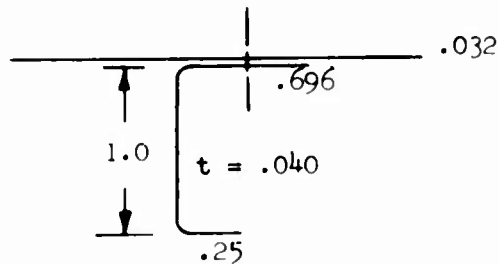

The stringers are clipped to the frames

$$M = [13.4 (25)^2] / 8 = 1,050 \text{ in. -lb.}$$

$$\bar{z} = \frac{1.01 (.04) (.5) + .23 (.04) (1.01)}{.696 (.072) + 1.24 (.04)}$$

$$= \frac{.020 + .0093}{.050 + .050}$$

$$= .243 \text{ in.}$$

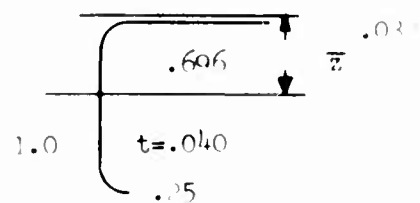
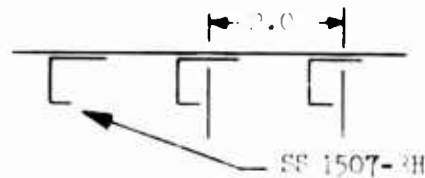

$$I_z = .696(.072) (.293)^2 + .23(.04) (717)^2 + \frac{1}{12} (.04) (1.01)^3 + .04(1.01) (.207)^2$$

$$= .0141 \text{ in.}^4$$

$$f_c = 1050(.293)/.0141 = 21,800 \text{ psi}$$

$$f_t = 1050(.717)/.0141 = 54,500 \text{ psi}$$

$$b/t = .696/.056 = 12.4$$

$$f_{cu} = 35,000 \text{ psi (Reference 60)}$$

$$f_{tu} = 76,000 \text{ psi (Reference 46)}$$

$$M.S. = 76,000/54,500 - 1 = + .40$$

Attachment of Floor Stringers to Frames:

$$P = 12.5(13.4) = 168 \text{ lb.}$$

Use clips with AD4 rivets

M.S. = High

Use AD4 rivets at 1.0 throughout structure.

Loads on the Critical Fitting:

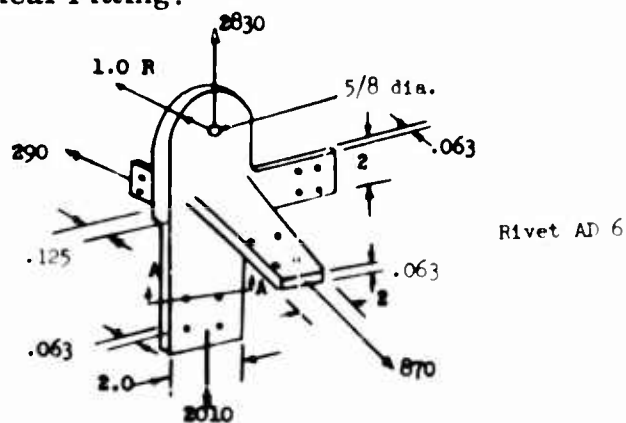

Figure 67. (U) Gun Crew Pod Typical Fitting

All fittings shall be made the same size.

Aluminum Forging 7075 T6

Section A-A:

$$A_{\text{net}} = (2 - .374) .063 = .102 \text{ in.}^2$$

$$f_t = 2,010 / .102 = 19,600 \text{ psi}$$

$$f_{tu} = 75,000 \text{ psi (Reference 46)}$$

M.S. = High

Lug Analysis:

Bearing and Shear Tearout

$$P'_u = K_{br} A_{br} F_{tu} \text{ (Reference 60)}$$

$$A_{br} = .625(.125)$$

$$= .078 \text{ in.}^2$$

$$a/D = .69 / .625 = 1.1$$

$$D/t = .625 / .125 = 5.0$$

$$K_{br} = 1.0 \text{ (Reference 60)}$$

$$P'_{bru} = .078(75,000) = 5,850 \text{ lb.}$$

Net Section Tension:

$$A_{\text{net}} = (2.0 - .625) .125 = .172 \text{ in.}^2$$

$$W/D = 2 / .625 = 3.2$$

$$K_t = .80 \text{ (Reference 60)}$$

$$P_{tu} = .80(75,000) (.172) = 10,300 \text{ psi}$$

$$\text{M.S.} = 5,850 / 2,830 - 1 = \underline{\text{High}}$$

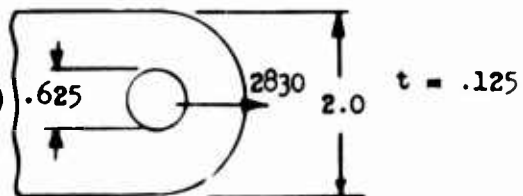

(U) Ammunition Pod for 105-mm. Howitzer, Structural Analysis

Loads for Design of Frames, Stringers and Skin:

Limit Load = 6,000 lb. over two-thirds of the floor area

Limit Load Factors - Vertical Takeoff

$N_z = 2.5$ (Reference 56)

Ultimate Load = 6,000 (2.5) (1.5) = 22,500 lb.

Loaded Area = $\frac{2}{3} (9)(7.33) = 44 \text{ ft.}^2$

Design Load = $22,500/44 = 512 \text{ lb./ft.}^2$ (over $\frac{2}{3}$ of floor area)

Loads for Design of Serviceable Floor:

Design Load = $200 (3.75) = 750 \text{ lb./ft.}^2$

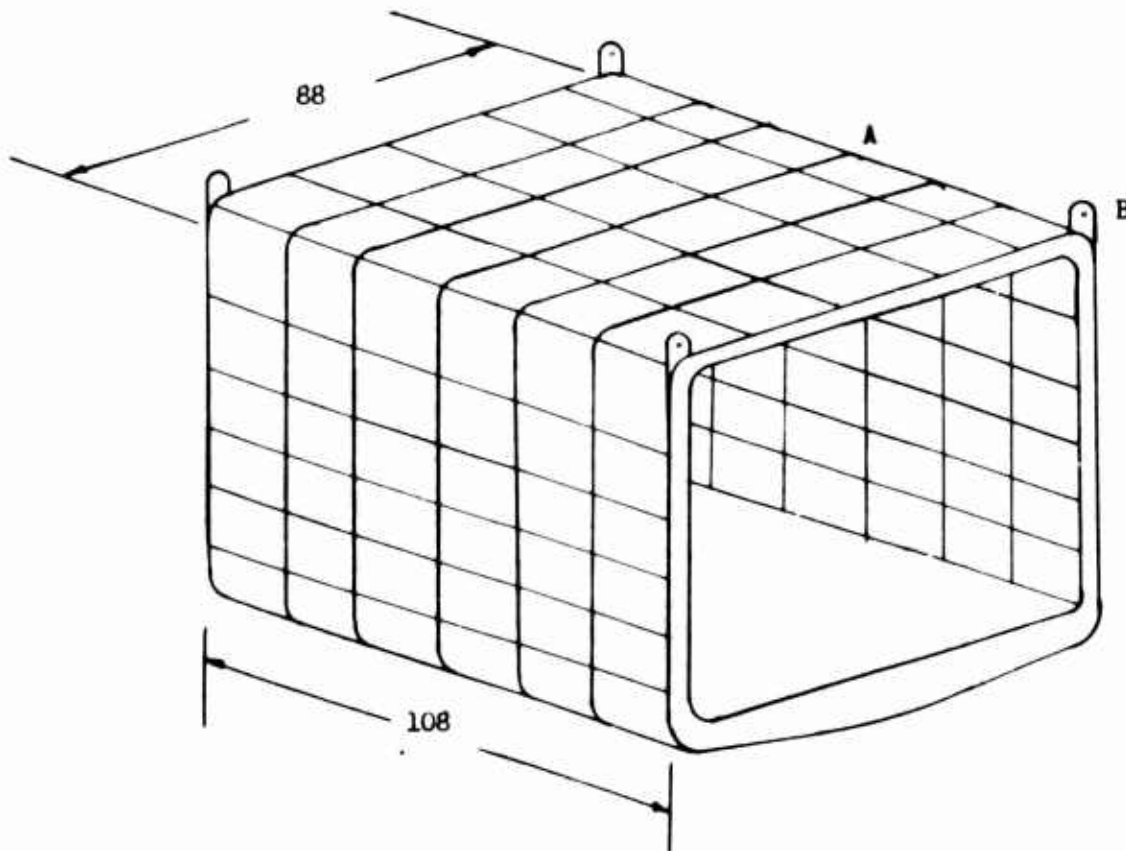

Figure 68. (U) Ammunition Pod for 105-mm. Howitzer

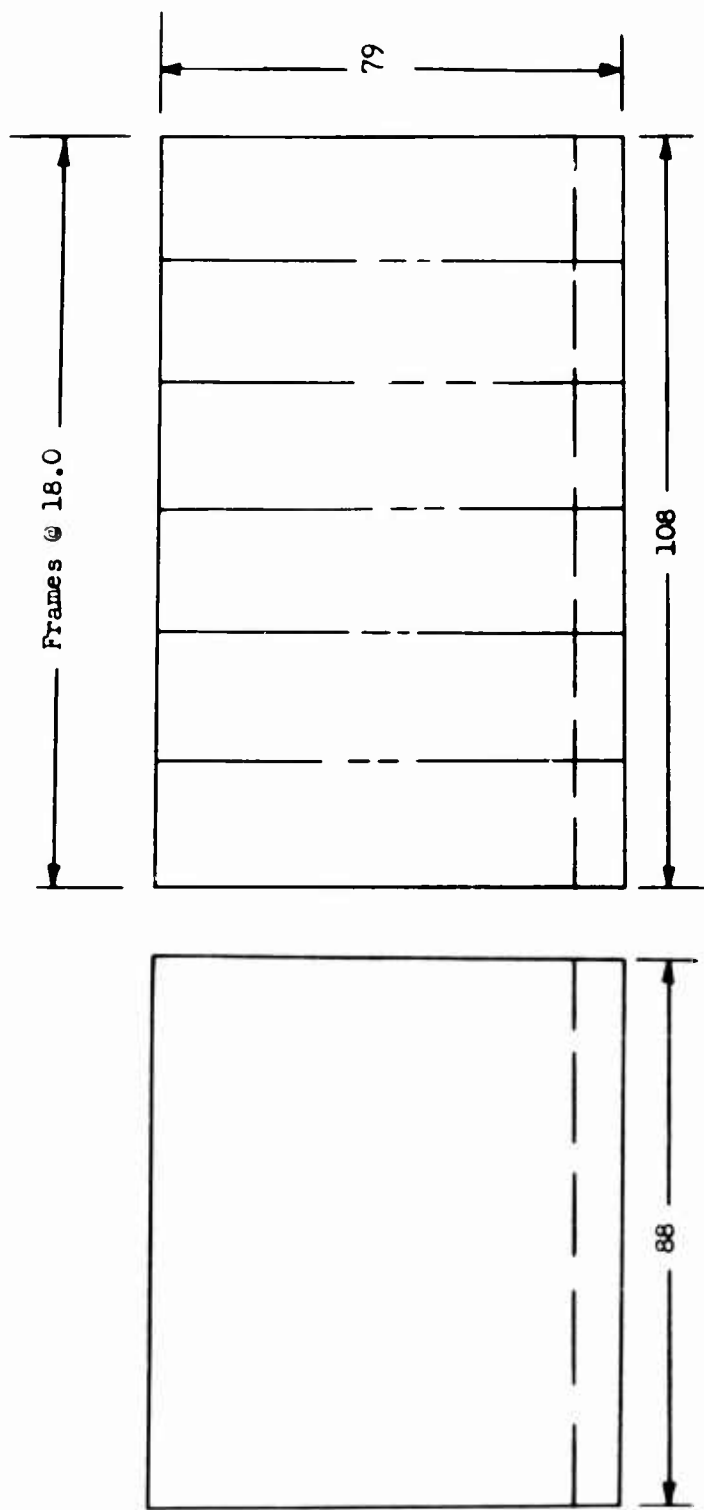

Figure 69. (U) Ammunition Pod For 105-mm. Howitzer

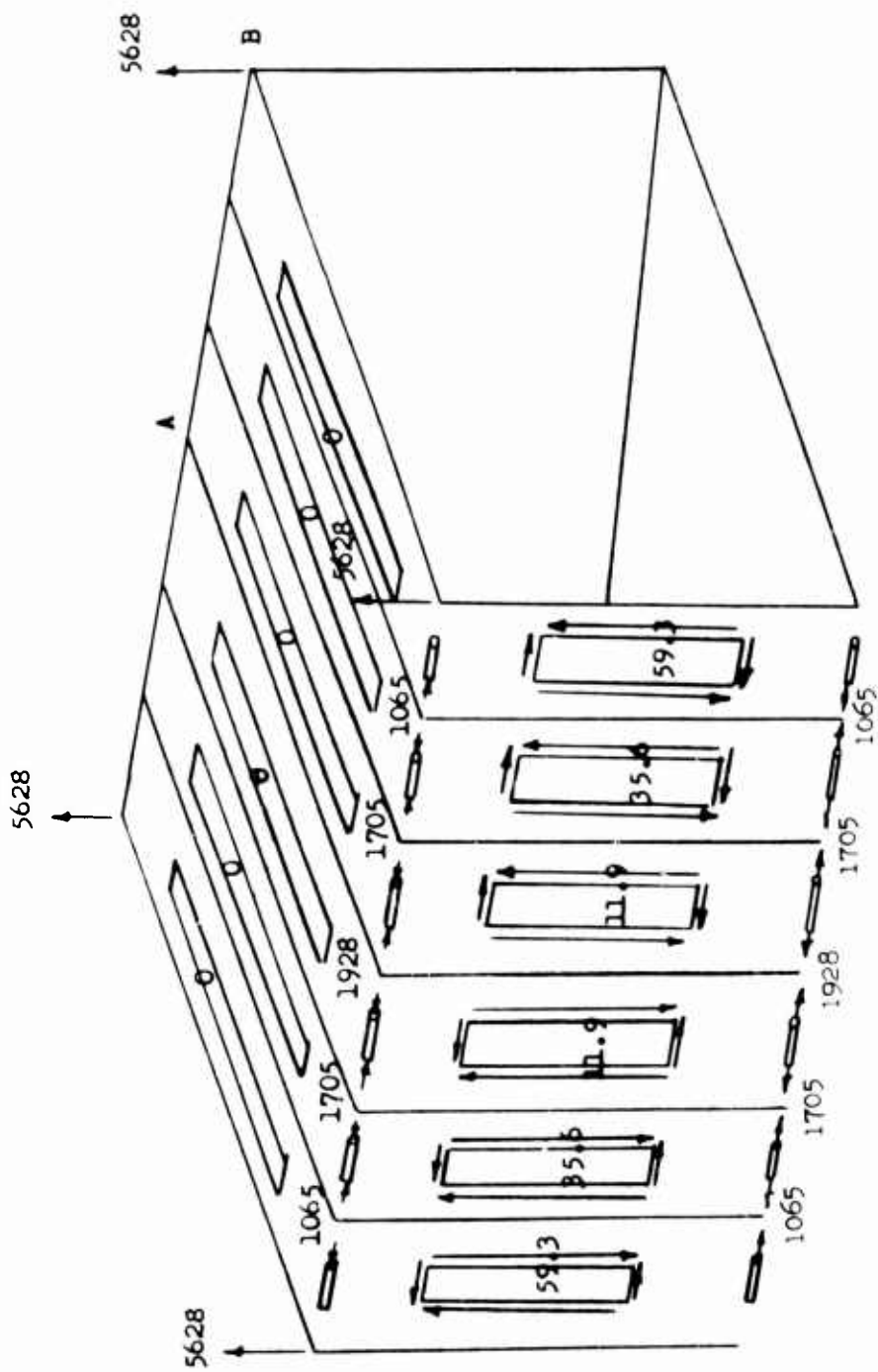

Figure 70. (U) Equilibrium of Ammunition Pod for 105-mm. Howitzer

Loading of a Typical Internal Frame: Frame A (Reference Figure 70)

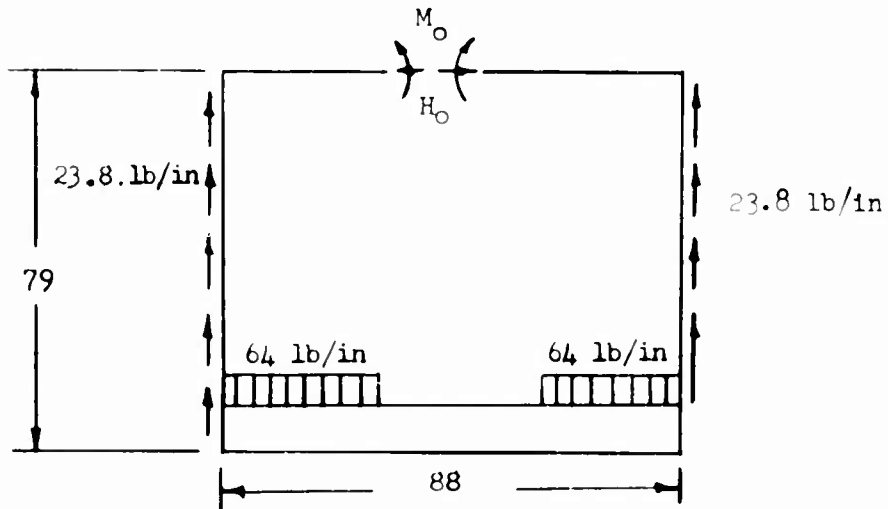

Figure 71. (U) Ammunition Pod - Internal Frame Applied Loads

Loading of External Frames: Frame B (Reference Figure 70)

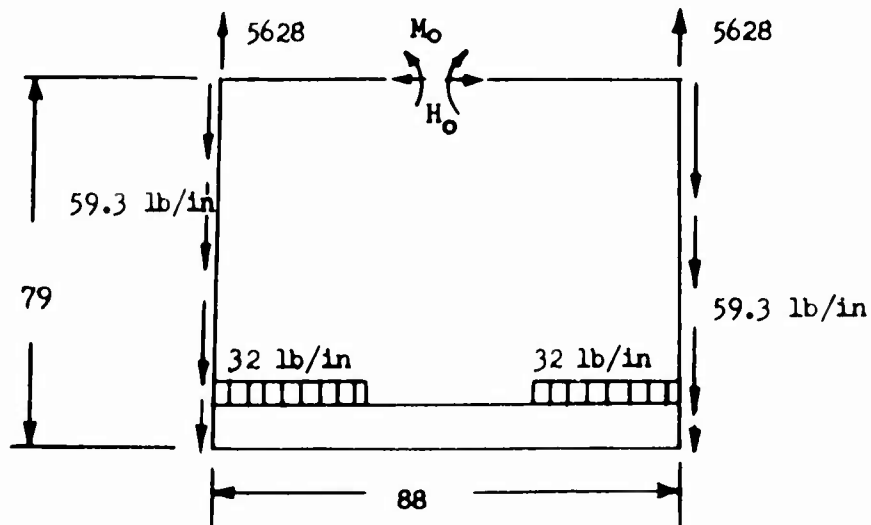

Figure 72. (U) Ammunition Pod - External Frame Applied Loads

Load Analysis of Internal Frame: Frame A

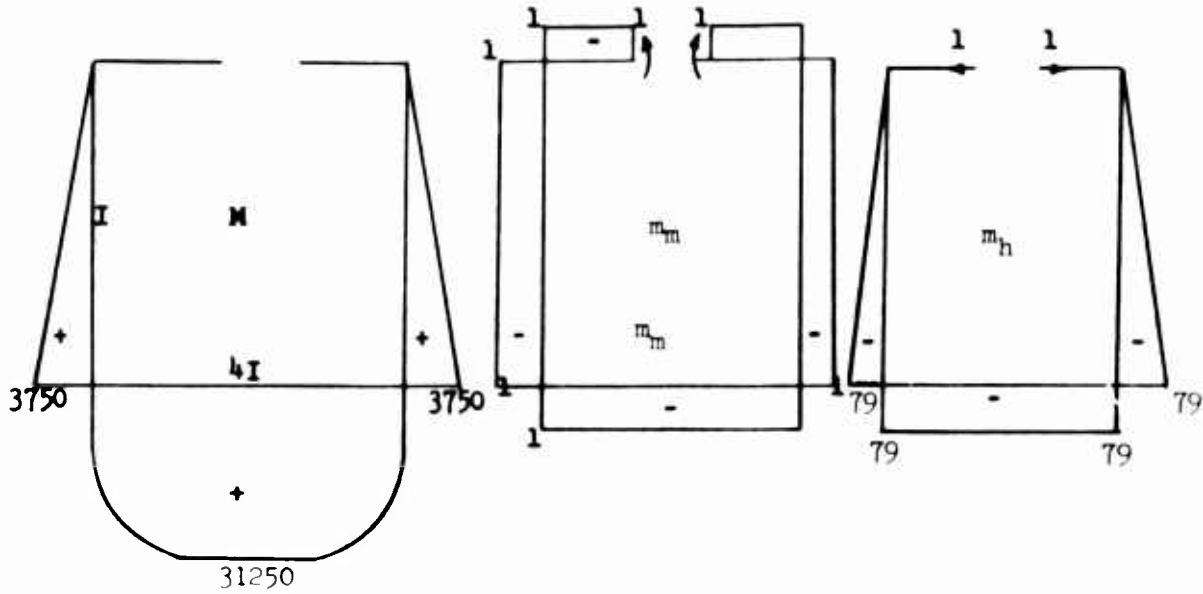

Figure 73. (U) Ammunition Pod - Internal Frame Analysis

In order to solve for the internal redundants M_0 and H_0 , the following simultaneous equations must be solved:

$$(1) \int \frac{M m_m ds}{I} + M_0 \int \frac{m_m^2 ds}{I} + H_0 \int \frac{m_m m_h ds}{I} = 0$$

$$(2) \int \frac{M m_h ds}{I} + M_0 \int \frac{m_h m_m ds}{I} + H_0 \int \frac{m_h^2 ds}{I} = 0$$

$$\int M m_m ds = (2)3,750(79) \frac{1}{2}(-1) + \frac{2(215000)-1}{4} = -850,000$$

$$\int \frac{m_m^2 ds}{I} = 268$$

$$\int \frac{m_m m_h ds}{I} = 7,979$$

$$\int \frac{m_h^2 ds}{I} = 878,108$$

$$M_{mh} ds = 2(3,750)(79)\frac{1}{2} \frac{2}{3} (-79) + \frac{2,215,000(-79)}{4}$$

$$= -59.6 \times 10^6$$

$$(1) -850 + .27 M_o + 8.0 H_o = 0$$

$$-59,600 + 8 M_o + 878 H_o = 0$$

$$M_o = 1,560 \text{ in. -lb.}$$

$$H_o = 54 \text{ lb.}$$

$$M_t = M + M_o m_m + H_o m_h$$

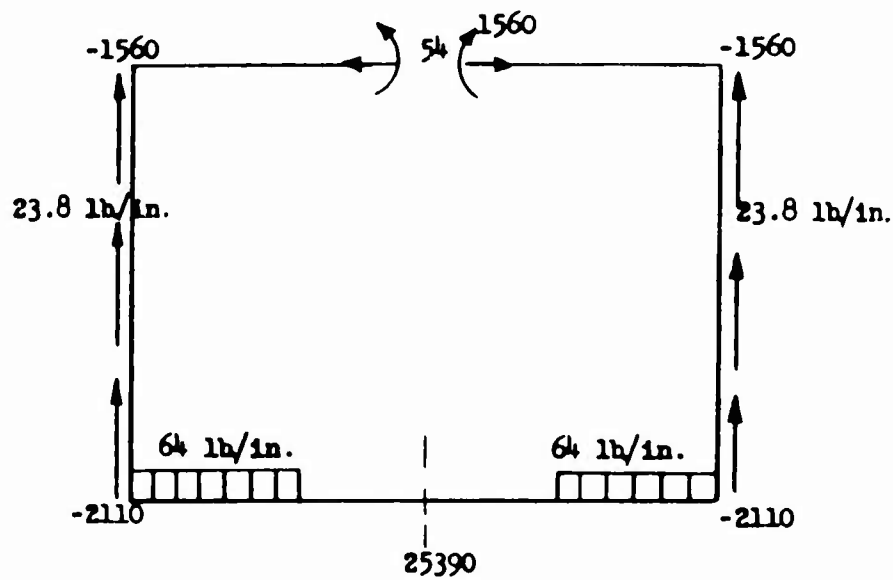

Figure 74. (U) Ammunition Pod - Internal Frame Bending Moments

Load Analysis of External Frame - Frame B

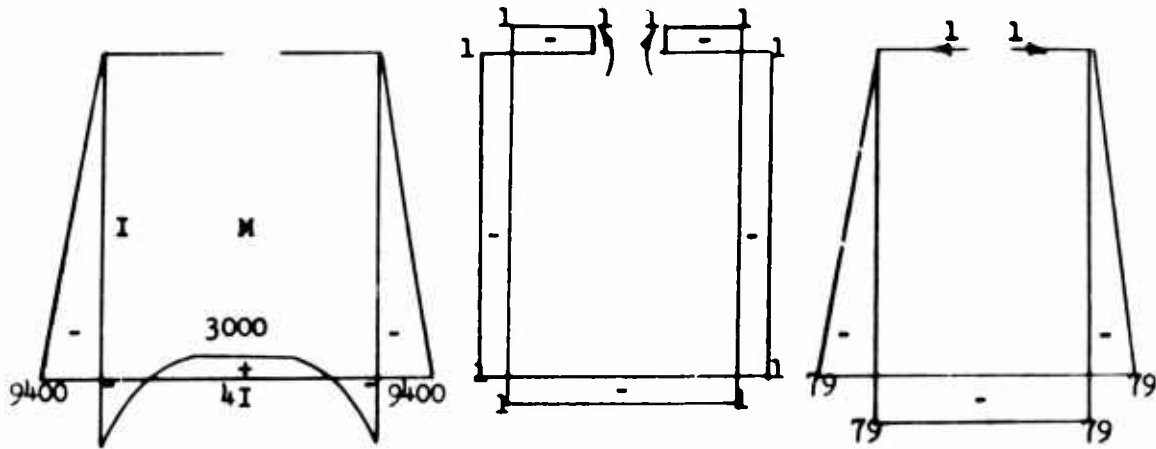

Figure 75. (U) Ammunition Pod - External Frame Analysis

$$(1) \int \frac{M m_m}{I} ds + M_o \int \frac{m_m^2}{I} ds + H_o \int \frac{m_m m_h}{I} ds = 0$$

$$(2) \int \frac{M m_h}{I} ds + M_o \int \frac{m_h m_m}{I} ds + H_o \int \frac{m_h^2}{I} ds = 0$$

$$\int M m_m ds = 2(-9,400)79 \frac{1}{2} (-1) + (-9,400)(88)(-1) \frac{1}{4} + 86,000(-1) \frac{1}{4}$$

$$= 745,000$$

$$\int M m_h ds = 2(-9,400)(79) \frac{1}{2} \frac{2}{3} (-79) + (9,400)88(-79) \frac{1}{4} +$$

$$86,000(-79) \frac{1}{4}$$

$$= 38.3 \times 10^6$$

$$\int \frac{m_m^2}{I} ds = 268$$

$$\int \frac{m_m m_h ds}{I} = 7,979$$

$$\int \frac{m_h^2 ds}{I} = 878,108$$

$$745 + 0.27 M_O + 8 H_O = 0$$

$$38,300 + 8 M_O + 878 H_O = 0$$

$$M_O = -2,000 \text{ in. -lb.}$$

$$H_O = -25 \text{ lb.}$$

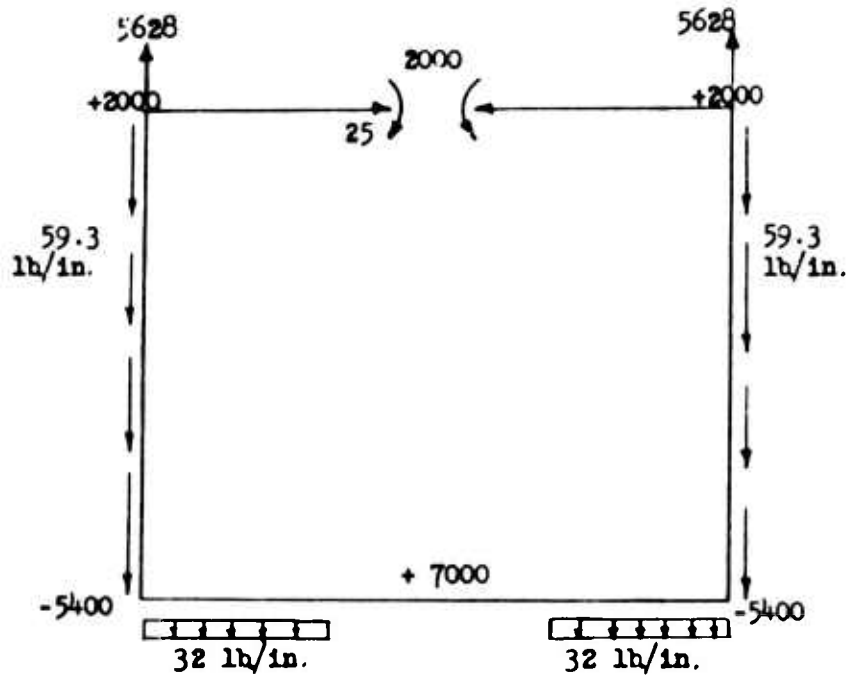

Figure 76. (U) Ammunition Pod - External Frame Bending Moments

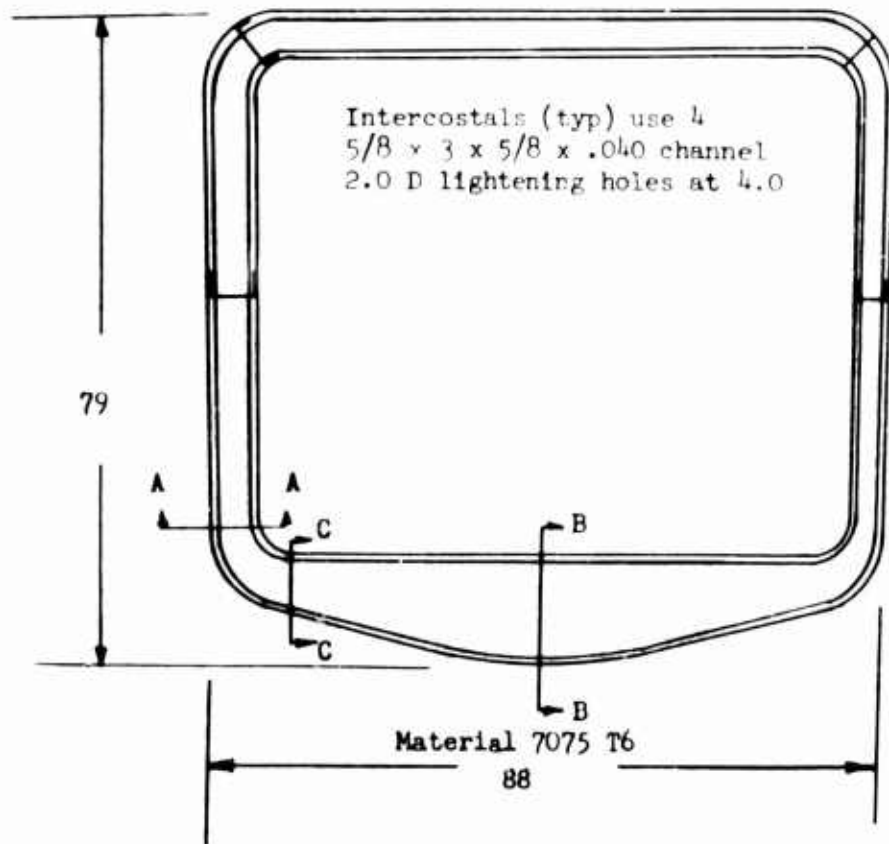
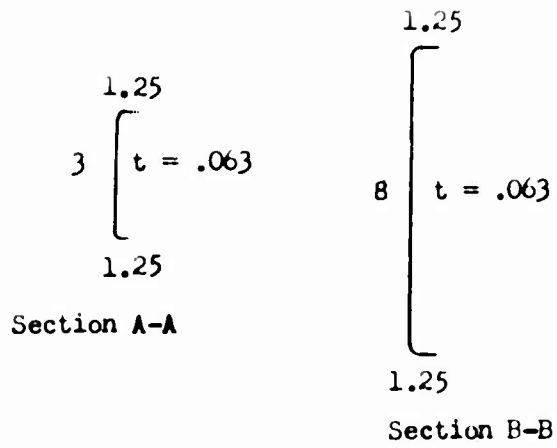

Figure 77. (U) 105-mm. Howitzer Ammunition Pod, Typical Frame

Frame Structural Analysis:

Frame A - Section B-B

$$I = [1.25(16)(2) + 512/12] \cdot .063$$

$$= 5.22$$

$$M = 25,390 \text{ in. -lb.}$$

$$f_c = 25,390(4)/5.22 = 19,400 \text{ psi}$$

$$b/t = 1.22/ (.063 + .016) = 15.5$$

$$f_{cu} = 22,500 \text{ psi (Reference 60)}$$

$$\text{M.S.} = 22,500/19,400 - 1 = +16$$

Shear in the Web Section C-C

$$f_s = 1,530/3(.063) = 8,000 \text{ psi}$$

$$b/t = 3/.063 = 47.5$$

$$f_{scr} = 18,000 \text{ psi (Reference 60)}$$

The web is shear resistant.

Frame B - Section A-A

$$I = [1.25(2.25)2(.063) + 27/12] (.063)$$

$$= .495$$

$$M = 5,400 \text{ in. -lb.}$$

$$f_c = \frac{940}{.345} - \frac{5,400(1.5)}{.495} = 13,700 \text{ psi}$$

$$b/t = 15.5, f_{cu} = 22,500 \text{ psi (Reference 60)}$$

$$\text{M.S.} = 22,500/13,700 - 1 = +.77$$

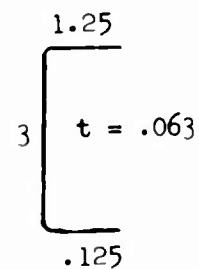
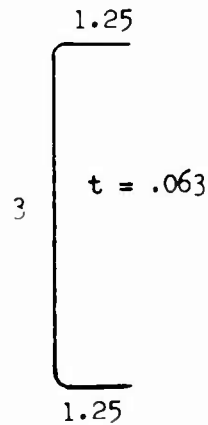

Longerons - Upper:

Channel 5/8 x 8 x 5/8 .040 7075 T6

$$A = 2.25(.040) \\ = .090 \text{ in.}^2$$

$$f_c = 1,920/.090 \\ = 21,500 \text{ psi}$$

$$b/t = 0.605/.040 = 15.0$$

$$f_{cu} = 28,500 \text{ psi (Reference 60)}$$

$$M.S. = 28,500/21,500 - 1 = +.32$$

Skin:

Outer panels: $q = 59.3 \text{ lb./in.}$

Use .040 7075 T6 skin with SS 1507 - 34 stiffeners at 8.0 inches

$$f_s = 59.3/.040 = 1,480 \text{ psi}$$

$$b/t = 8/.040 = 200$$

$$f_{scr} = 1,600 \text{ psi (Reference 60)}$$

The panel is shear resistant.

Inner Panels: $q = 35.6 \text{ lb./in.}$

Use .032 7075 T6 skin with SS 1507-34 stiffeners at 8.0 inches

$$f_s = 35.6/.032 = 1,120 \text{ psi}$$

$$b/t = 8/.032 = 250$$

$$f_{scr} = 1,050 \text{ psi (Reference 60)}$$

There is no significant skin buckling.

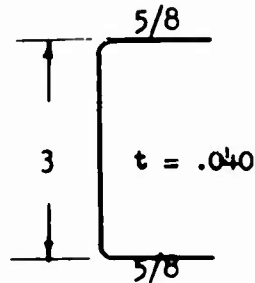

Floor:

Use .032 skin with SS 1507 - 3H stringers @ 2.0 inches ultimate floor load = 750 lb/ft²

$$= 5.2 \text{ psi}$$

Load on the stringers = 10.4 lb/in.

Stringers are simply supported over a span of 18.0 inches

$$M = \frac{10.4(18)^2}{8} = 423 \text{ in. -lb.}$$

$$\bar{Z} = .293 \text{ in.}$$

$$I_z = .0141 \text{ in.}^4$$

$$f_c = 423(.293)/.0141 = 8,800 \text{ psi}$$

$$b/t = .696/.056 = 12.4$$

$$f_{cu} = 35,000 \text{ psi (Reference 60)}$$

M. S. = High

Fitting:

Section A-A

$$A_{net} = (2 - .375) .084$$

$$= .137 \text{ in.}^2$$

$$f_t = 5,628/.137 = 41,000 \text{ psi}$$

$$f_{tu} = 75,000 \text{ psi (Reference 46)}$$

$$M. S. = 75,000/41,000 - 1$$

$$= +.83$$

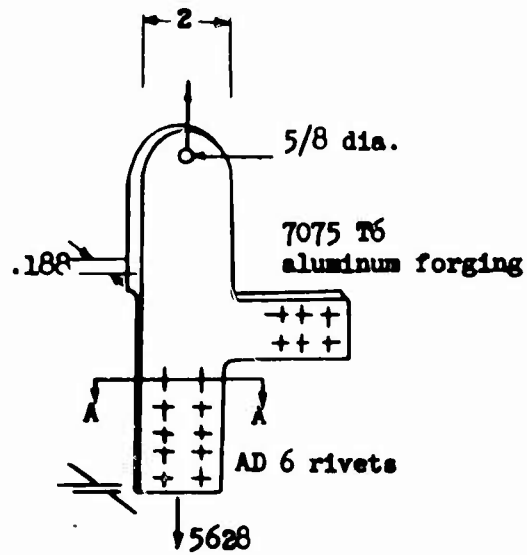
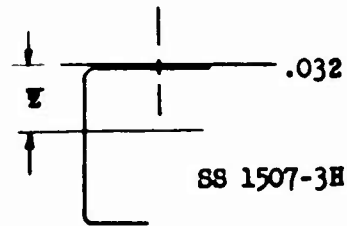

Figure 78. (U) Ammunition Pod - Typical Fitting

Lug Analysis:

Bearing and shear tear-out

$$P'_u = K_{br} A_{br} F_{tu} \text{ (Reference 60)}$$

$$A_{br} = .625(.125) = .078$$

$$a/D = 1.06/.625 = 1.7$$

$$D/t = .625/.188 = 3.3$$

$$K_{br} = 1.63$$

$$P'_u = .078 (1.63) (75,000) \\ = 9,500 \text{ lb.}$$

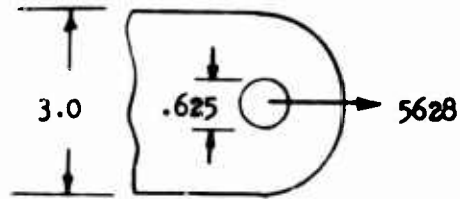

Net Section Tension

$$A_t = .445$$

$$W/D = 3.0/.625 = 4.8$$

$$K_t = 0.7$$

$$P_t = .7(.445) (75,000) \\ = 23,300 \text{ lb.}$$

$$M. S. = 9,500/5,628 - 1 = +.68$$

(U) XM102 - 105-mm. FIRING PLATFORM, STRUCTURAL ANALYSIS

Weapon at 70° elevation, 0° traverse

Rod Pull = 30 in.

Recoil = 27,900 lb.

Impact Factor = 3.0

Weapon Weight = 3,000 lb.

Ultimate Recoil Force = 3(27,900) (1.5) = 125,000 lb.

Floor Load

Limit Overpressure = 1.5 psi

95th-percentile man = 200 lb.

Ammunition = 35 lb.

$$p = \text{Floor Load} = 1.5 \left[1.5 + \frac{235}{144} \right] = 4.7 \text{ psi}$$

Consider that the platform is on three supports at Section B-B (Reference Figure 83)

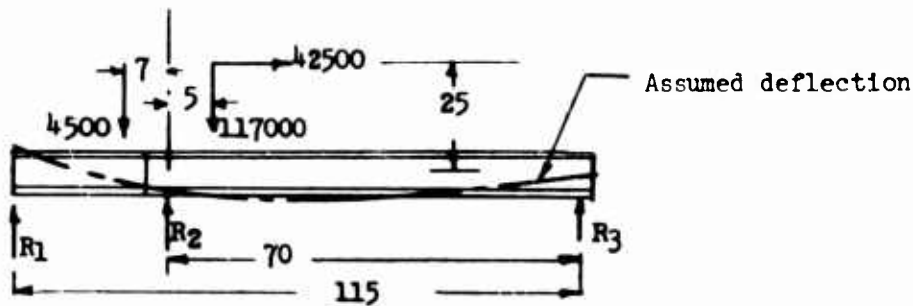

Based on the assumed deflection curve, R_1 carries no load due to recoil.

$$\sum M_{R_2} = 0$$

$$117,000(5) + 42,500(25) - 4,500(7) = 70R_3$$

$$R_3 = 23,150$$

$$\sum F_v = 0$$

$$R_z = 121,500 - 23,150$$

$$\sum = 98,350 \text{ lb.}$$

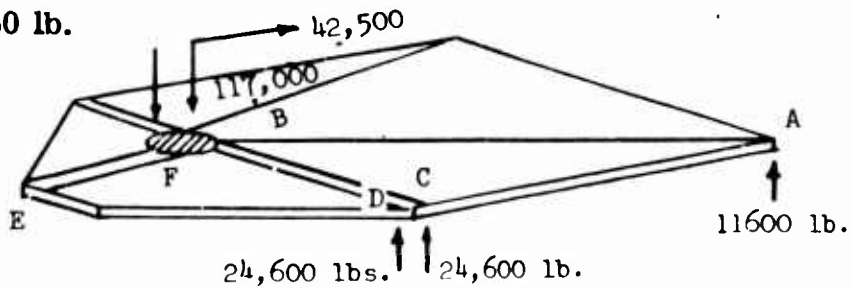

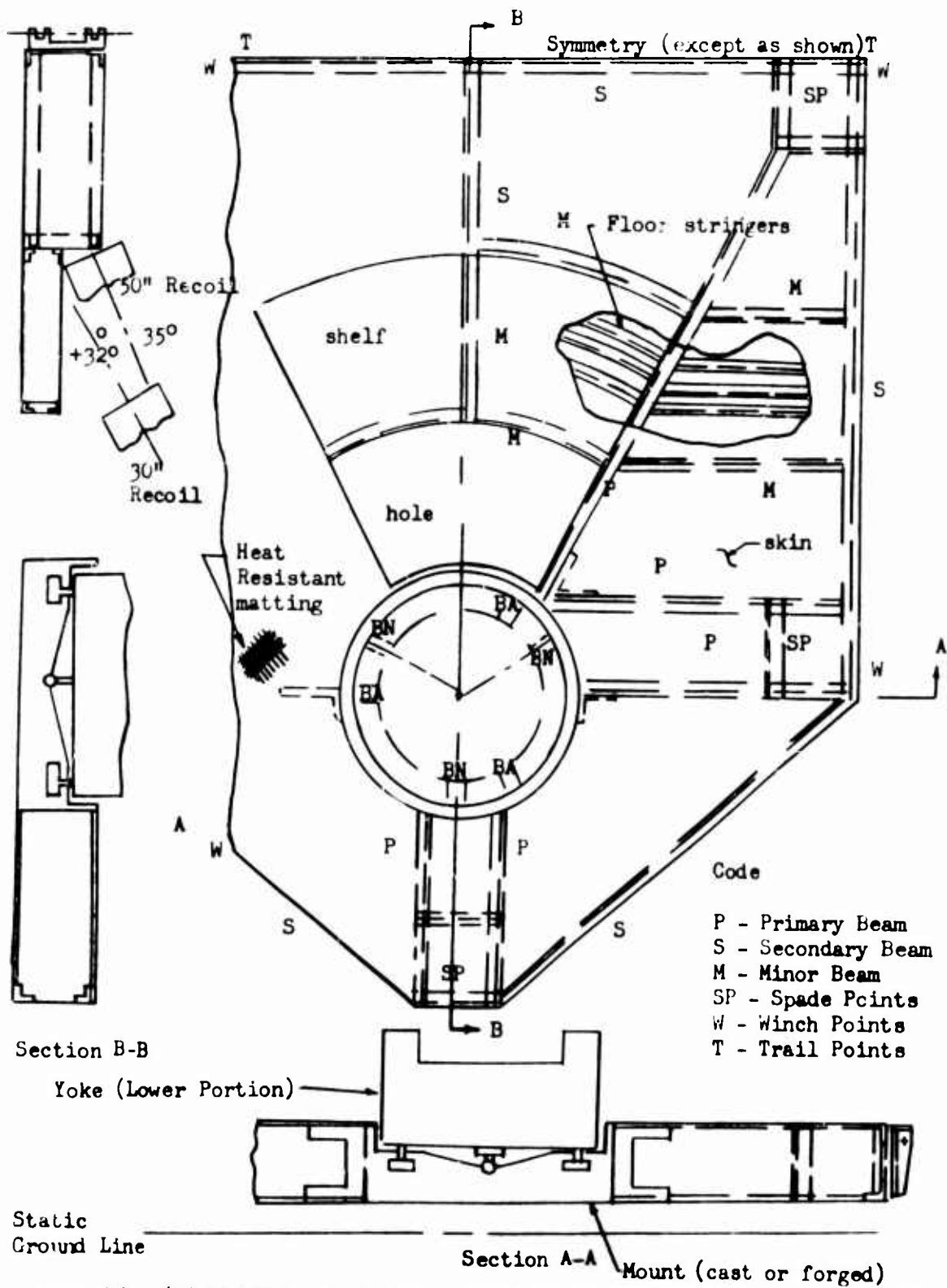
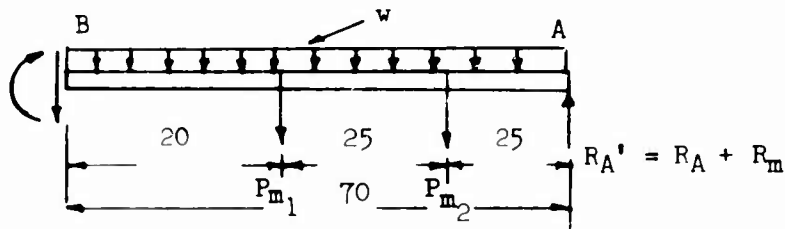

Figure 79. (U) XM102 - 105-mm. Howitzer Firing Platform. Scale 1/20

Critical Primary Member A-B



$$w = \text{floor load} = 30 \text{ in.} (4.7 \text{ lb./in.}^2) = 140 \text{ lb./in.}$$

P_{m1} = floor load transmitted through minor beams

$$P_{m1} = 565 \text{ lb.}$$

$$P_{m2} = 1,130 \text{ lb.}$$

$$R_A' = 11,600 + \frac{70(140)}{2} + 45(1,130) + \frac{20(565)}{70}$$

$$= 11,600 + 4,900 + 725 + 160$$

$$= 17,385$$

$$M_B = 17,385(70) - 1,130(45) - 565(20) - \frac{140(70)^2}{2}$$

$$M_B = 805,000 \text{ in. -lb.}$$

Primary Beam:

Angle:

$$A = 2.10$$

$$I = 1.70$$

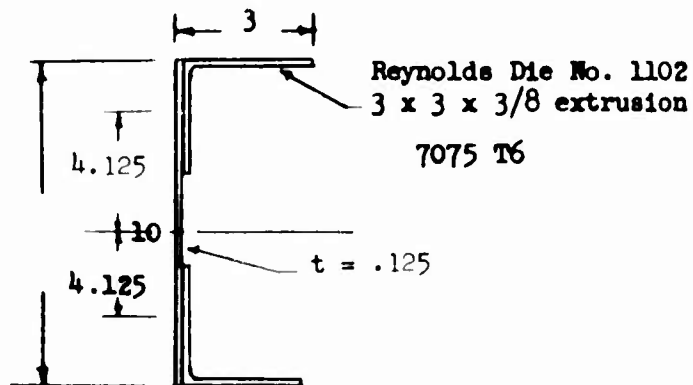

Section:

$$A = 4.2 + 1.25 = 5.45$$

$$I = 2(1.70) + 2 \left[2.10(4.125)^2 \right] + \frac{1}{12} (.125) (10)^3$$

$$= 3.40 + 71.5 + 10.4$$

$$= 85.3$$

$$M = 805,000 \text{ in. -lb.}$$

$$P_c = 70/40 (21,250) = 37,500$$

$$f_c = 37,500/5.45 + 805,000(5)/85.3$$

$$= 7,000 + 47,000 = 54,000 \text{ psi}$$

$$b/t = 2.81/.375 = 7.5$$

$$f_{cu} = 68,500 \text{ psi (Reference 60)}$$

$$M. S. = 68,500/54,000 - 1 = +.26$$

Secondary Beam:

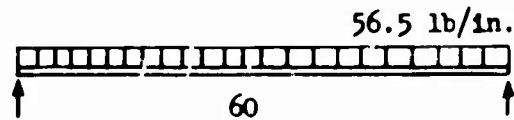

$$\text{Floor Load} = 12(4.7) = 56.5 \text{ lb. /in.}$$

$$M = \frac{56.5 (60)^2}{8} = 25,500 \text{ in. -lb.}$$

$$I = \left[1.5(25) (.072) \right] 2$$

$$+ \frac{1}{12} (.072) (1000)$$

$$= 5.4 + 6 = 11.4$$

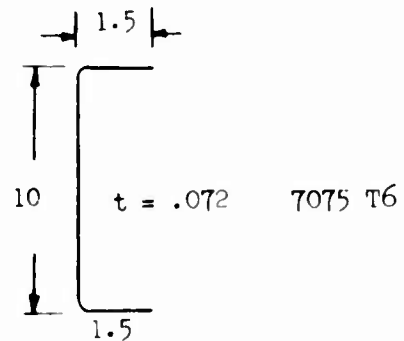

Use .040 floor 7075 T6

Stringers 1 x 1 x .050 @ 2.0 7075 T6

Typical Span = 30 in.

Load = 9.4 lb./in.

$$M = \frac{9.4 (30)^2}{8} = 1,060 \text{ in. -lb.}$$

$$\bar{z} = \frac{1(.05)}{.140} = .355$$

$$I = .090(.355)^2 + \frac{1}{12} (.05) \\ + .05 (.14)^2 \\ = .0154$$

$$f_c = 1,060(.355)/.0154 = 24,500 \text{ psi}$$

$$b/t = .98/.070 = 14.6$$

$$f_{cu} = 30,000 \text{ psi (Reference 60)}$$

$$M.S. = 30,000/24,500 - 1 = +.22$$

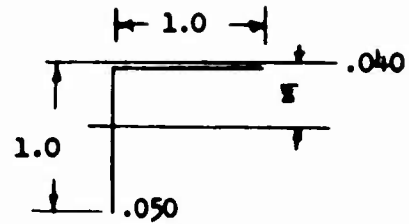

(U) YCH-54A EVALUATION OF THE YCH-54A FOR THE 318-MM. ROCKET

The limit overpressures on various portions of the fuselage for maximum elevations and maximum angles of traverse are shown in Figures 28 and 29. These pressures are obtained from the pressure candle shown in Figure 27.

The limits of elevation and traverse are as follows:

Elevation 0° to $+55^\circ$
Traverse $\pm 10^\circ$

By imposing these limits it can be shown that no further modifications to the fuselage are required beyond those made for the 105-mm howitzer.

Fuselage

The ultimate average overpressures on the fuselage are:

$$\begin{aligned} \text{Right Side} &= 1.5(6.25) = 9.4 \text{ psi} \\ \text{Bottom} &= 1.5(2.5) = 3.75 \text{ psi} \end{aligned} \quad (\text{Reference Figures 28 \& 29})$$

The ultimate capabilities of the modified YCH-54A fuselage in these areas are:

$$\begin{aligned} \text{Right Side} &: 21 \text{ psi} \\ \text{Bottom} &: 10.6 \text{ psi} \end{aligned} \quad (\text{Reference Table 31})$$

The structural margins of safety in this area are high by comparison of the figures above.

Rotor Blades

The blades are positioned as shown in Figure 30. The overpressures in the plane of the blades when firing aft at 55° elevation and 10° traverse are also shown. It can be seen that the blades at no time intersect the pressure candle. No structural damage to the blades will be encountered during firing of the 318-mm rocket.

Landing Gear - Right Side

Examination of the pressures on the fuselage during a 0° elevation firing indicates that the ultimate overpressure on the right-side landing gear support structure will not exceed 3.75 psi. Reference Figures 28 and 29. It has been found that the landing gear support structure has an ultimate capability of 5.1 psi. A structural margin of safety is therefore insured.

Gun Crew Pod

The same pod used for the 105-mm howitzer weapon-aircraft combination is used for the 318-mm rocket configuration.

Firing Platform

The platform used for the 105-mm howitzer is modified slightly, as shown in Figure 80, for the 318-mm rocket.

Overhead Monorail

An overhead monorail system is used both to store the missiles in flight and then move them to the firing platform upon landing. The design of this system is shown in Figure 82.

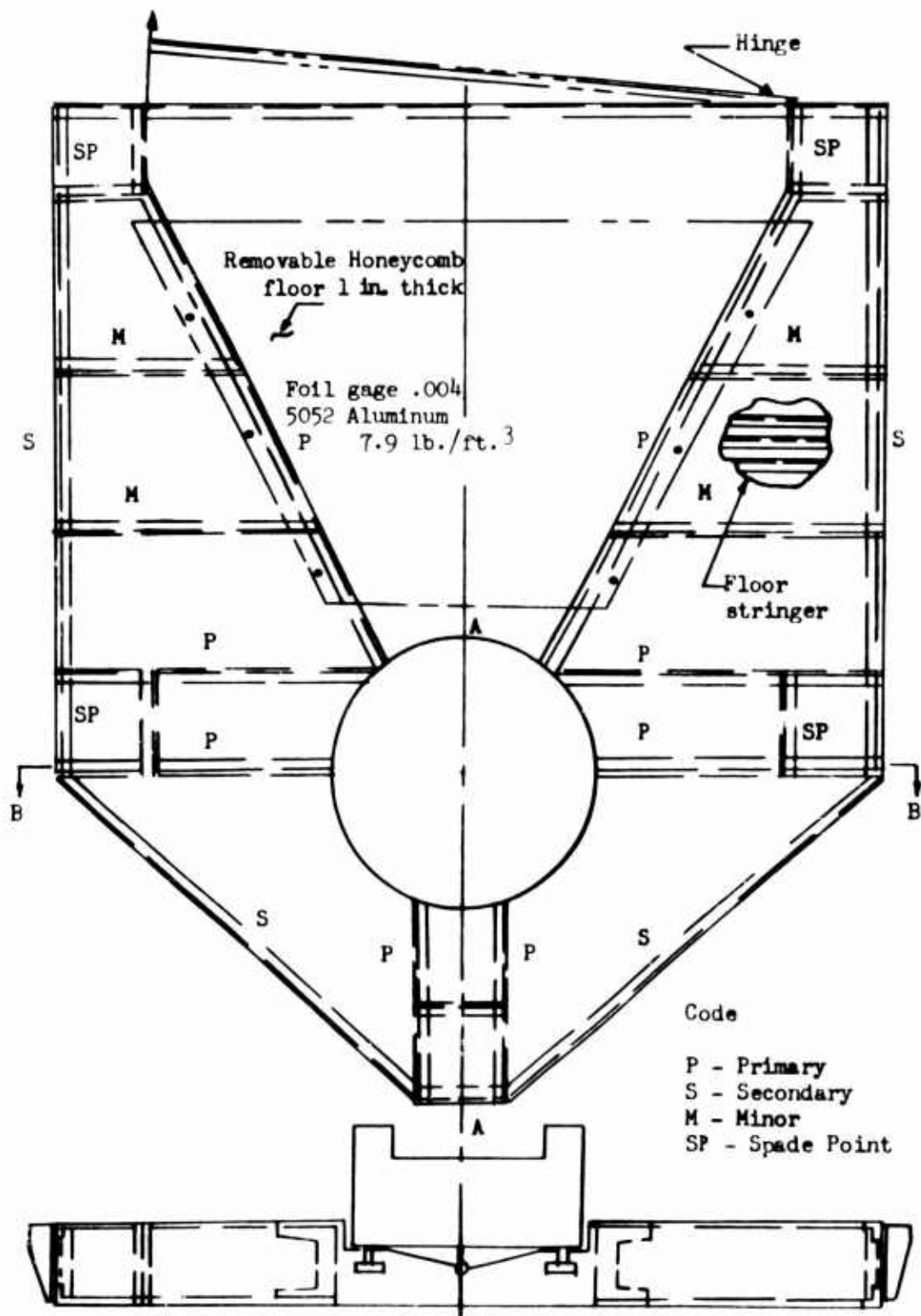

Section B B
 Figure 80. (U) 318-mm Rocket - Firing Platform

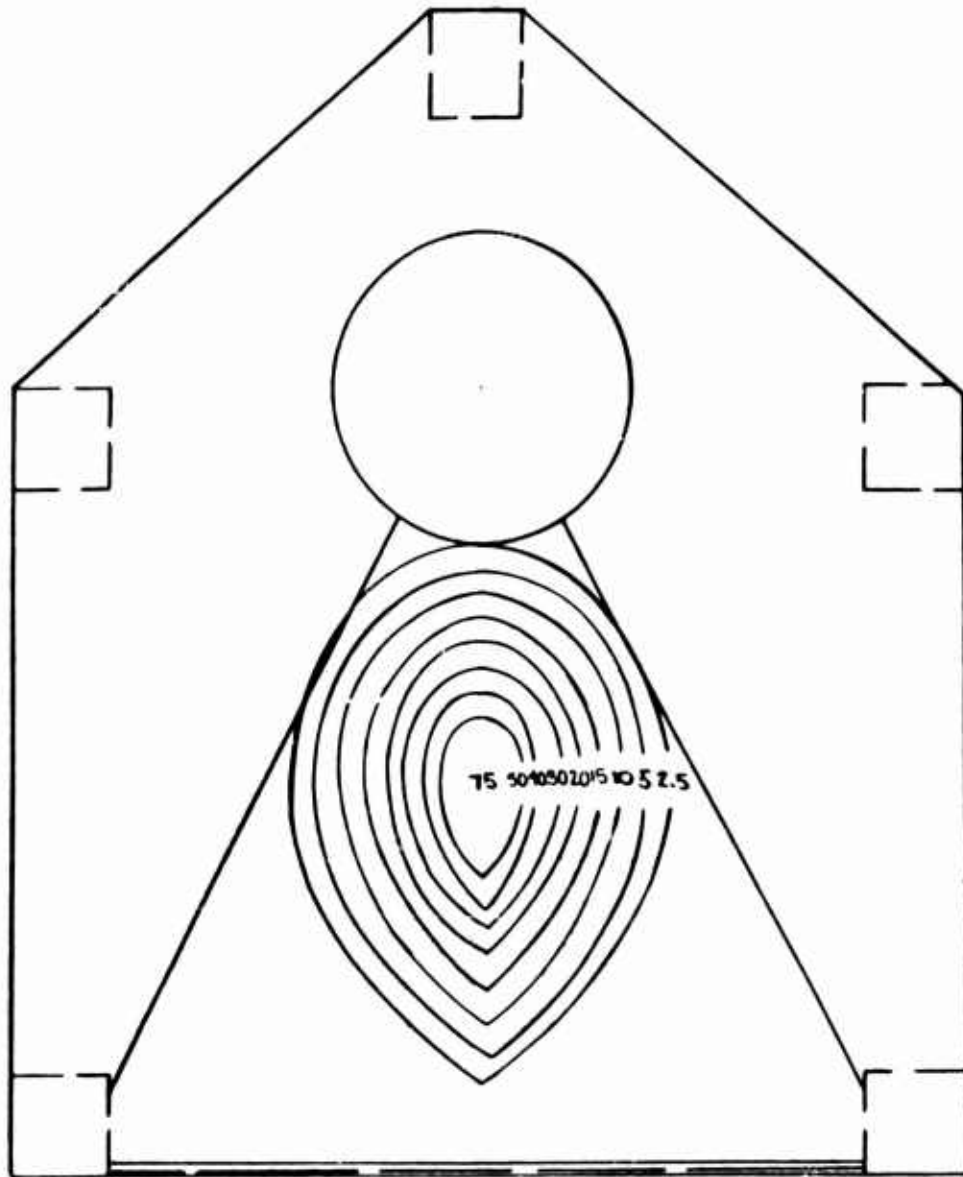

**Figure 81. (U) 318-mm Rocket - Firing Platform
Limit Overpressures**

(U) 318-mm. Rocket Firing Platform

This platform is the same as the 105-mm. howitzer firing platform, except as shown. The differences are as follows:

1. The floor directly behind the weapon mount is replaced by a removable honeycomb floor.
2. The rear secondary member is replaced by a hinged primary member.

The removable honeycomb floor and the hinged member are moved out of the way during weapon firing in order to prevent severe damage by the high overpressures directly in back of the missile.

The hinged member also serves to protect the left-side landing gear from the direct blast of the weapon.

The 105-mm. howitzer firing platform was designed for an ultimate recoil force of 125,000 lb. when firing at an elevation of 70°. There is no recoil force encountered during the firing of a 318-mm. rocket; therefore, the use of the same platform for the 318-mm. rocket insures a structural margin of safety.

Analysis of Removable Honeycomb Floor

Use 1-inch-thick floor
Foil gage .004 5032 Aluminum
7.9 lb/ft³

Use .032 Aluminum Skin Top and Bottom

Flat Compression: 200-lb man, 2G load factor over 1 ft².

$$P = 200(2)(1.5) = 600 \text{ lb.}$$
$$A = 144 \text{ in.}^2$$

$$P/A = 600/144 = 4.15 \text{ psi}$$
$$\text{Allowable} = 758 \text{ psi}$$
$$\text{M. S.} = \text{High}$$

Transverse Shear:

$$P = 200(2)(1.5) = 600 \text{ lb.}$$
$$L = 12 \text{ in.}$$
$$q = 600/12 = 50 \text{ lb./in.}$$

$$\text{Allowable} = 264 \text{ lb./in.}$$
$$\text{M. S.} = \text{High}$$

Compression in Skin: Average span, 60 in.
Assume 2 men at midspan

$$M = 600(30) = 18,000 \text{ in.-lb.}$$
$$P_c = \frac{M}{d} = 18,000 \text{ lb.}$$

$$f_c = \frac{18,000}{12(.032)} = 47,000 \text{ psi}$$

$$f_{cu} = 73,000 \text{ psi (Reference 60)}$$

$$\text{M. S.} = 73,000/47,000 - 1 = +.56$$

(U) 318-mm. Rocket Overhead Monorail

The monorail is designed to support four 318-mm. rockets under the fuselage during flight. These rockets are supported by beams which attach to hard points on the fuselage. The tracks are 7075 T6 extruded "C" sections and the beams are 7075 T6 extruded channels.

Each rocket weighs 878 lb. and 25 lb. is added for a thermal blanket. The design is for an ultimate vertical load factor of 3.75.

318-mm. Rocket Overhead Monorail

Weapon	878 lb.
Thermal Blanket	25 lb.
Total	903 lb.

Rail Analysis (Reference Figure 82)

Members AB and CD each support one-half the weight of four missiles under an ultimate load factor of 3.75

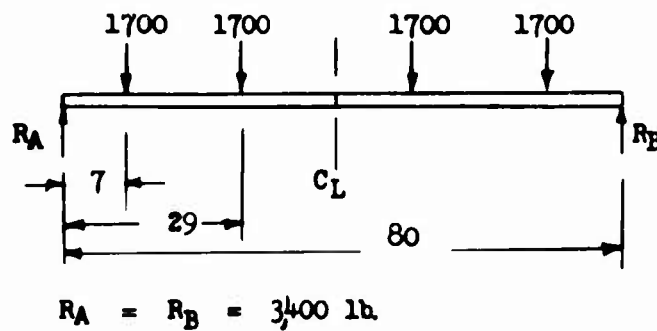

$$\begin{aligned} M_{\max} &= 3,400(29) - 1,700(22) \\ &= 99,000 - 37,500 \\ &= 61,500 \text{ in.-lb.} \end{aligned}$$

Analysis at typical section

$$Z = \frac{2 [1(.25)(2.375) + 2.25^2(.25) + 1.25(.25)(.125)]}{2 [.25 + 2.25(.25) + 1.25(.25)]}$$

$$= 1.12 \text{ in.}$$

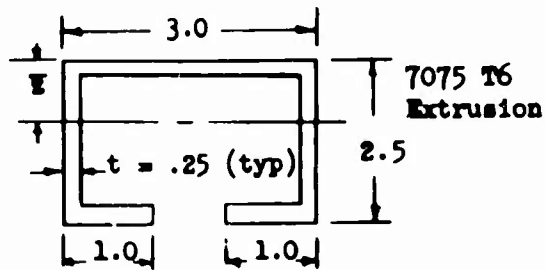

$$I_z = 3(.25)(.995)^2 + 2(.25)(1.255)^2 + \frac{1}{12} (.5)(2)^3 + .5(2)(.13)^2$$

$$= 1.885$$

$$f_c = 61,500 (1.12)/1.885 = 36,500 \text{ psi}$$

$$f_t = 61,500 (1.38)/1.885 = 45,000 \text{ psi}$$

$$b/t = 2.75/.25 = 11$$

$$f_{cu} = 78,000 \text{ psi (Reference 60)}$$

$$f_{tu} = 77,000 \text{ psi (Reference 46)}$$

$$M.S. = \frac{77,000}{45,000} - 1 = +.71$$

Local Bending of Rail:

$$M = 850 (.5)$$

$$= 425 \text{ in.-lb.}$$

$$\frac{I}{C} = \frac{1}{6} (.25)^2 = .0104$$

$$f_b = 425/.0104 = 41,000 \text{ psi}$$

$$f_{tu} = 77,000 \text{ psi (Reference 46)}$$

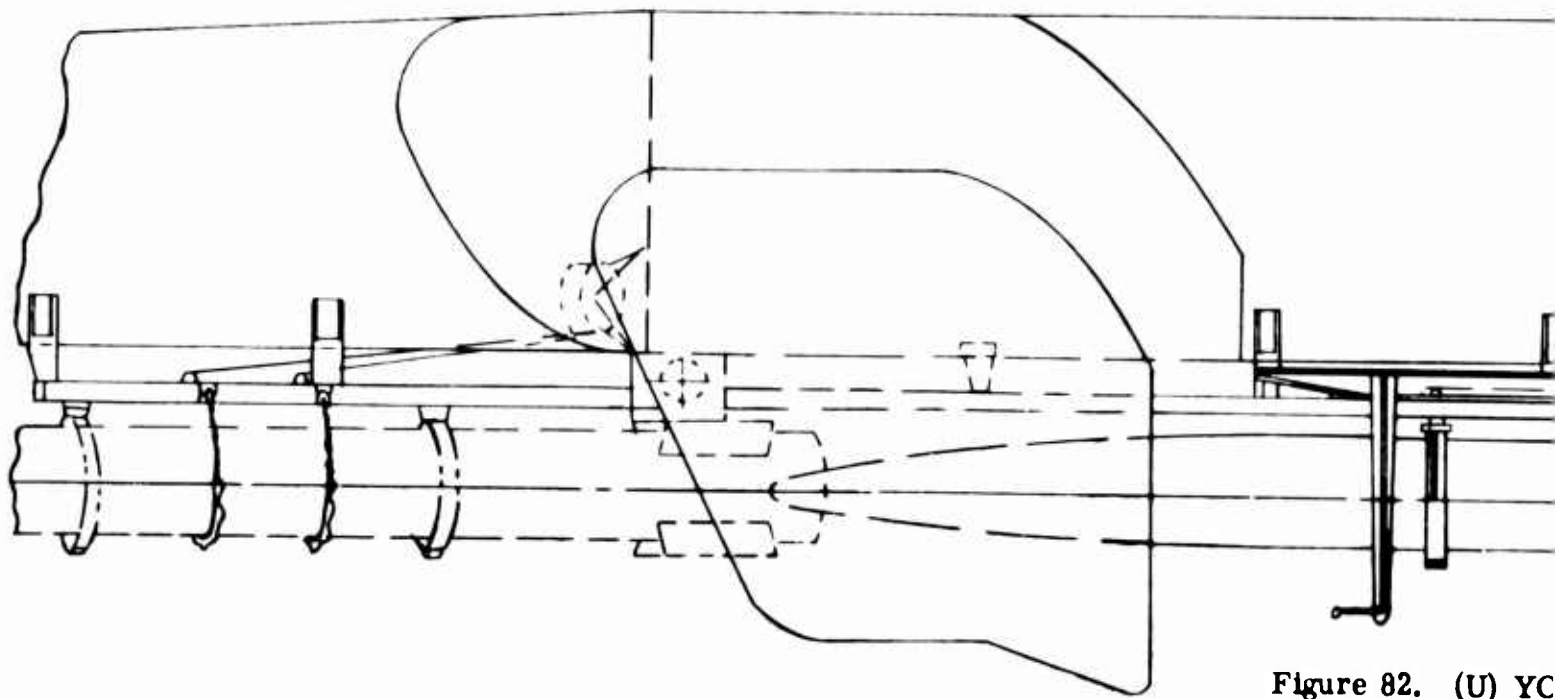
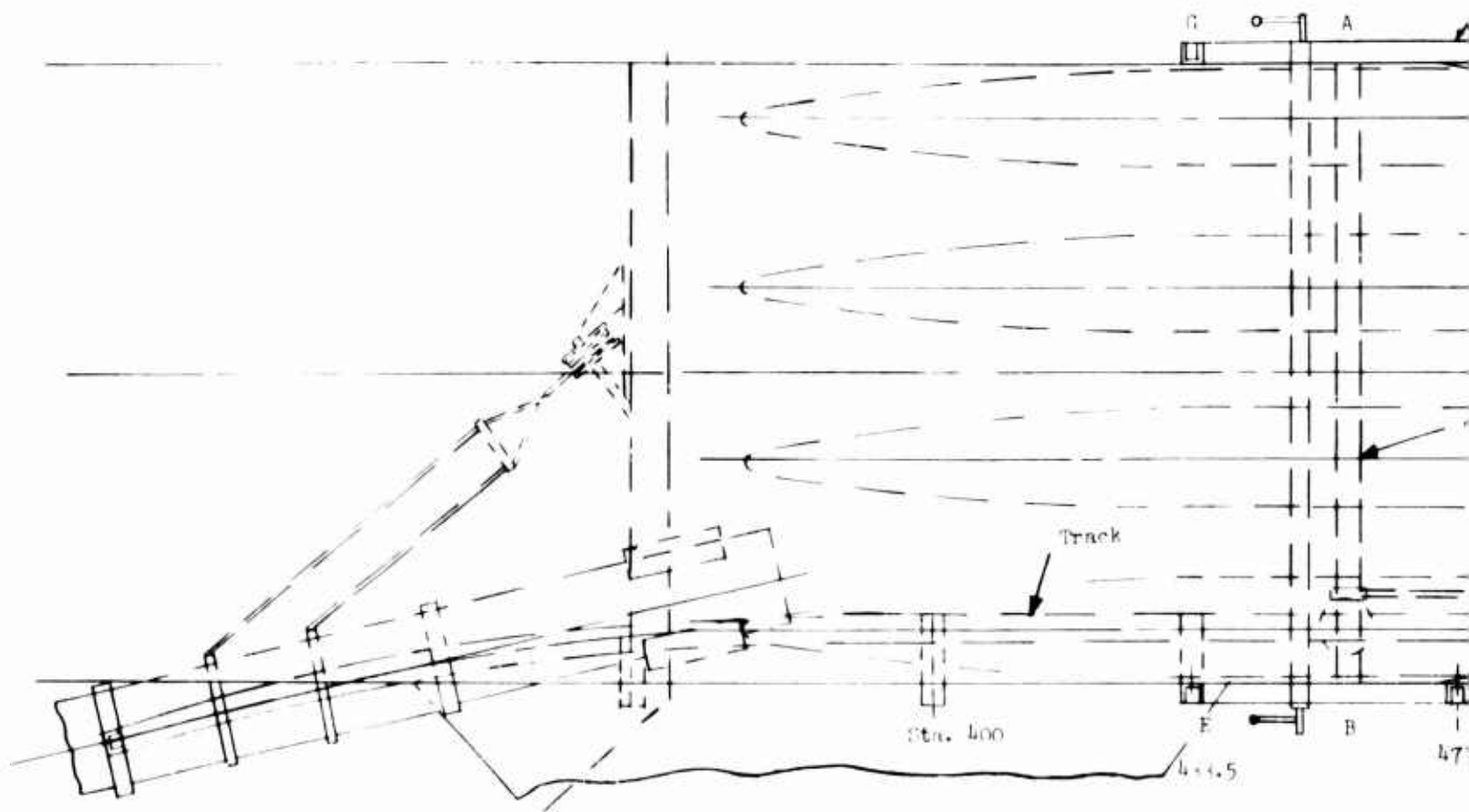

Figure 82. (U) YC
Rocket = 1/20 Roc

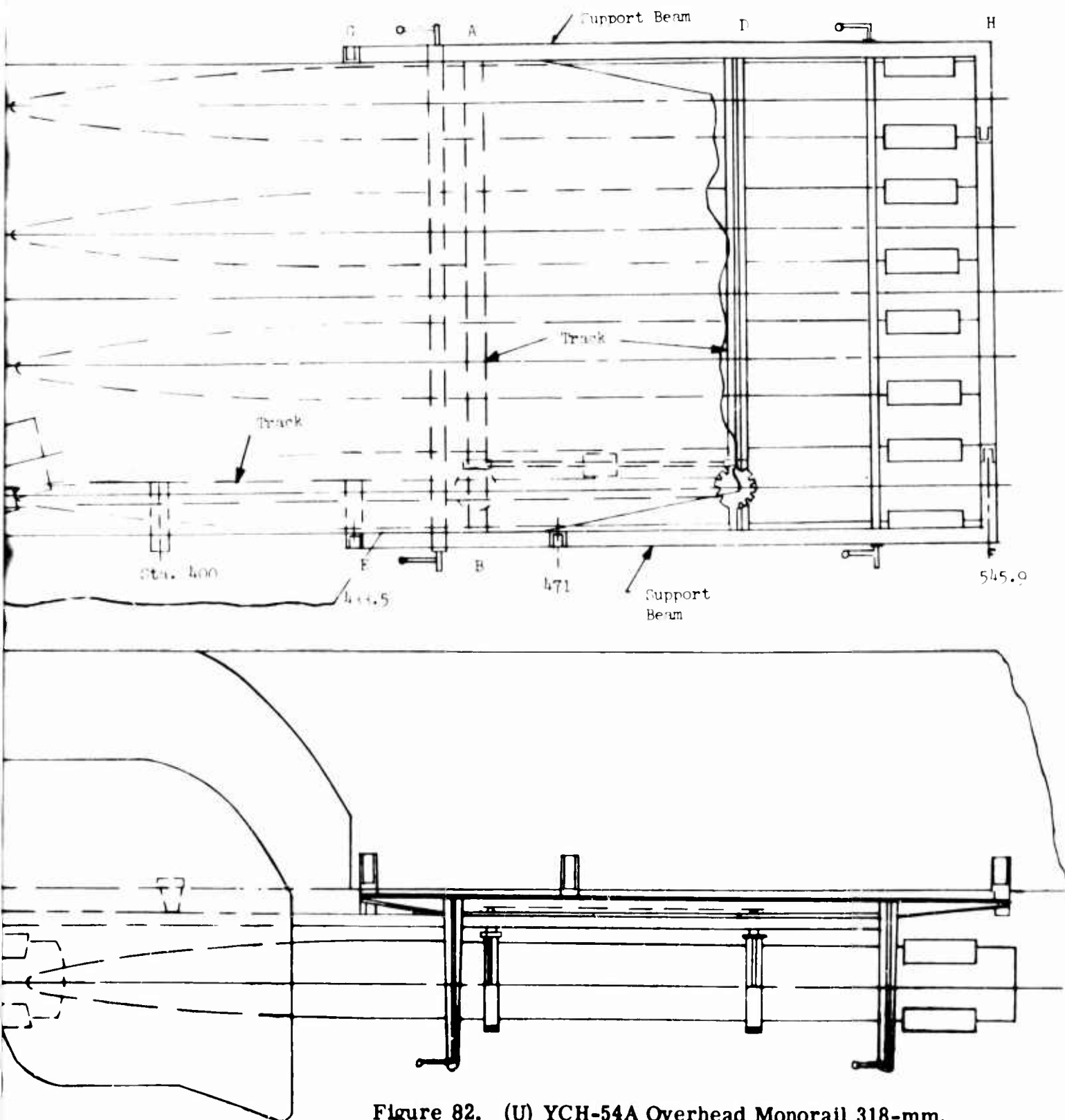
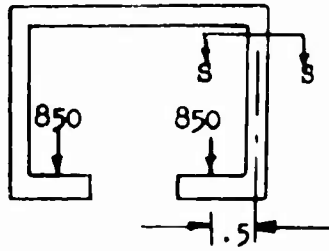
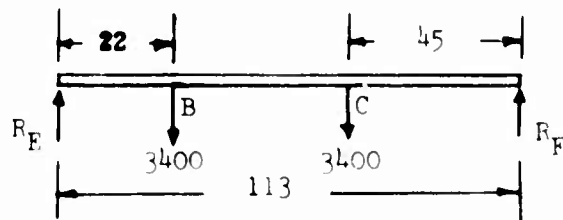

Figure 82. (U) YCH-54A Overhead Monorail, 318-mm.
 Rocket = 1/20 Rocket

$$M.S. = 77,000/41,000 - 1 = +.88$$



Support Beams EF and GH (Reference Figure 82):



$$\sum M_E = 0$$

$$113 R_F = 3,400(22) + 3,400(68)$$

$$R_F = 2,700 \text{ lb.}$$

$$R_E = 6,800 - 2,700$$

$$= 4,100 \text{ lb.}$$

$$M_{\max} = 45(2700) = 122,000 \text{ in.-lb.}$$

Use a 2 x 4 x 2 x .250 7075 T6 Extruded Channel

$$I = 4.313$$

$$d = 4.0$$

$$f_b = 122,000(2)/4.313 = 56,500 \text{ psi}$$

$$b/t = 1.875/.25 = 7.5$$

$$f_{cu} = 68,000 \text{ psi (Reference 60)}$$

$$M.S. = 68,000/56,500 - 1 = +.20$$

(U) 4.5-INCH ROCKET MOUNT FOR S61A ALTERNATE AIRCRAFT

Estimated Weight of Rocket Pod:

Seven 4.5-in. rockets at 43 lb.	=	300
Seven rocket tubes at 14 lb.	=	98 lb.
Rings and fairing	=	50 lb.
	=	<u>448 lb.</u>

Flight Loads:

$$\left. \begin{array}{l} \text{Vertical load factor } n_z = 2.5 \\ \alpha_y = 1.55 \end{array} \right\} \text{ (Reference 57)}$$

$$\text{Distance, fuselage c.g. to pod c.g.} = 4.0 \text{ ft.}$$

$$\text{Ultimate vertical load factor} = 1.5 \left[2.5 + \frac{1.55(4)}{32.2} \right] = 4.03$$

$$\text{Ultimate vertical load factor} = 4.03(448) = 1,800 \text{ lb.}$$

Firing Loads:

$$\text{Vertical load} = 1.5(448) = 670 \text{ lb.}$$

Blast reaction for 8 tubes at 140°F ambient temp. is 1,900 lb.

$$\begin{aligned} \text{Ultimate blast for 7 tubes} &= 1.5 \frac{(7)}{8} 1,900 \\ &= 2,500 \text{ lb.} \end{aligned}$$

Rocket Pod Internal Loads - Flight (Reference Figure 84)

$$P = \frac{10.5(1,800)}{6} = 3,150$$

$$S = \frac{1,800}{3} = 600$$

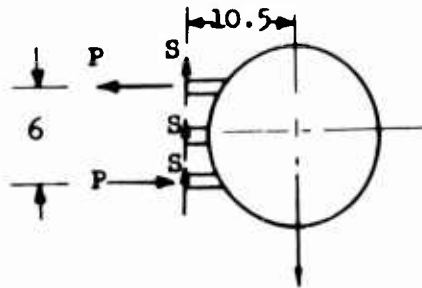

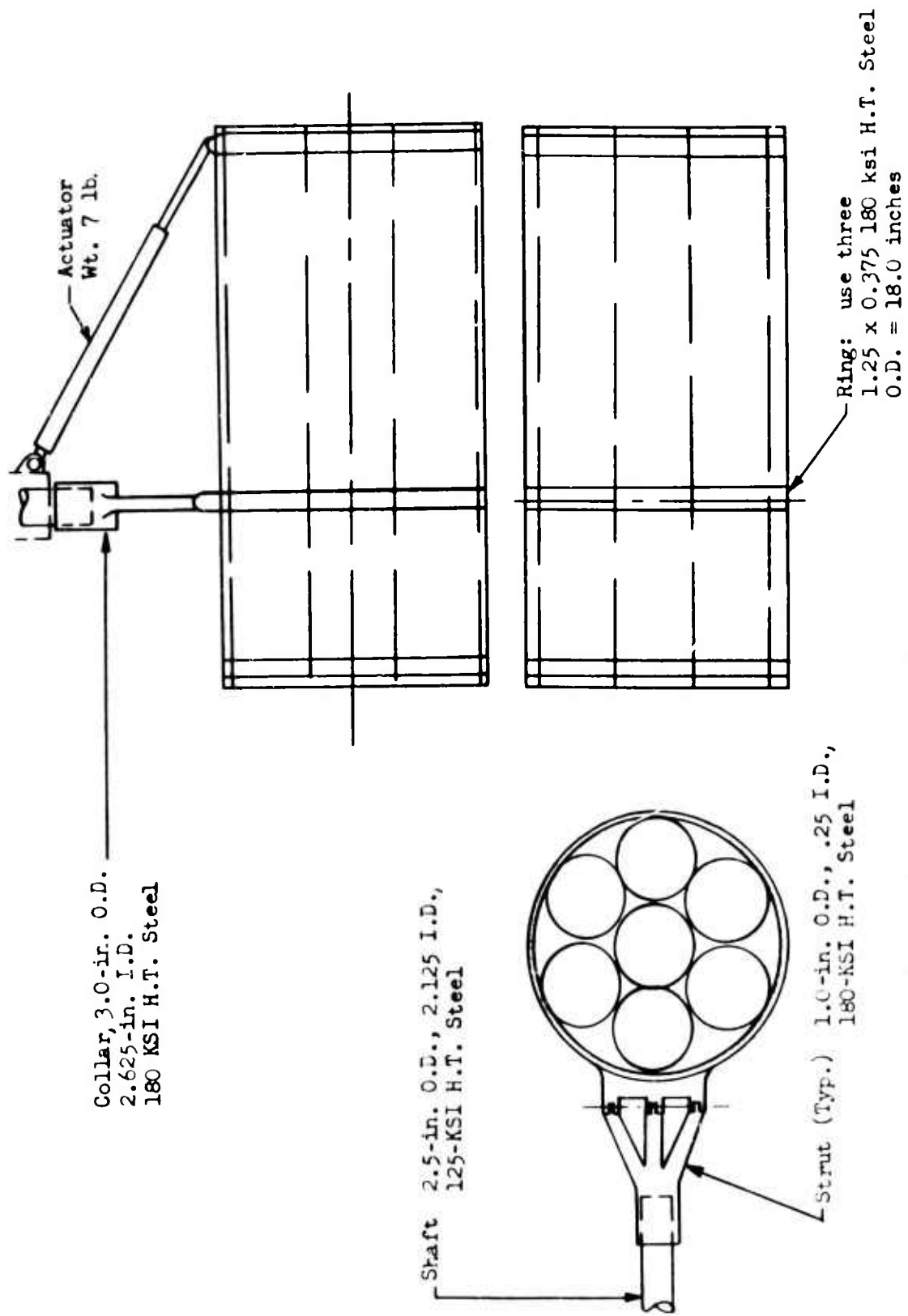
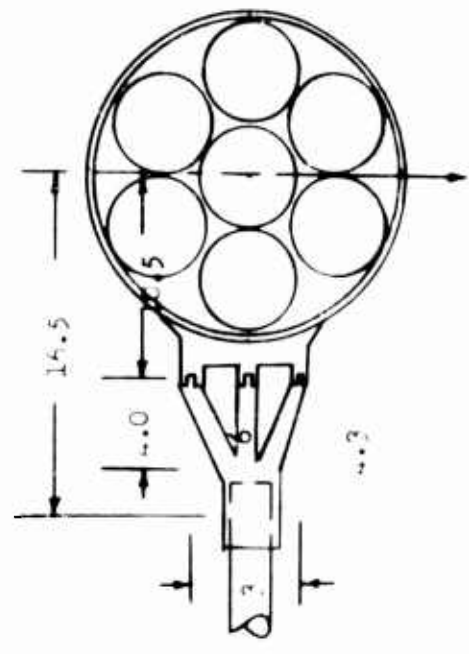
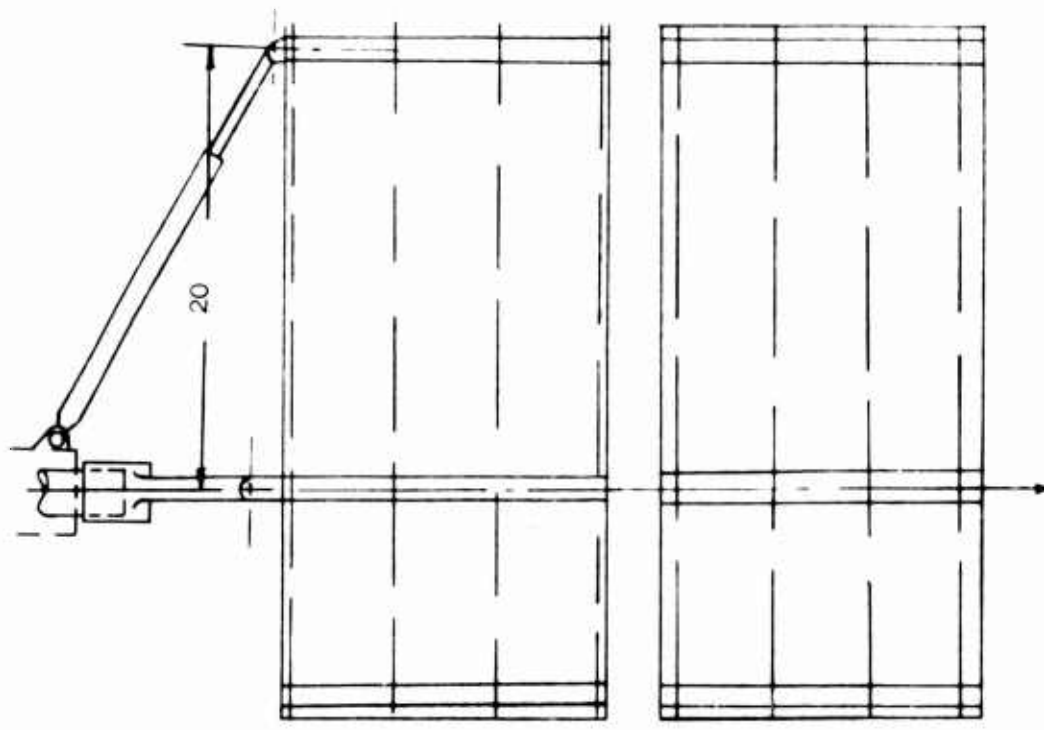

Figure 83. (U) S-61A Rocket Pod Support Structure



1800
1800
Figure 84. (U) Rocket Pod Support - Flight Loads

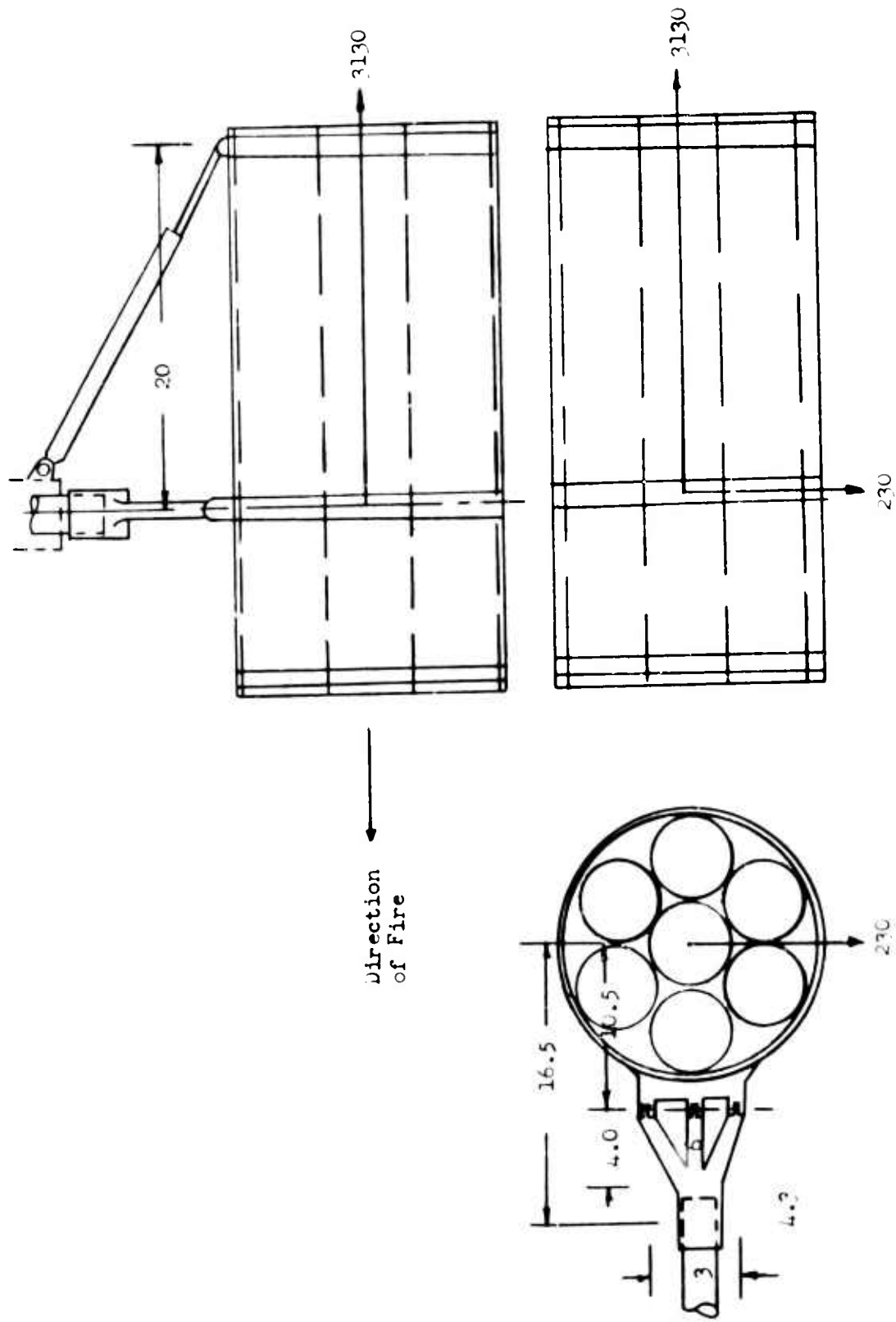
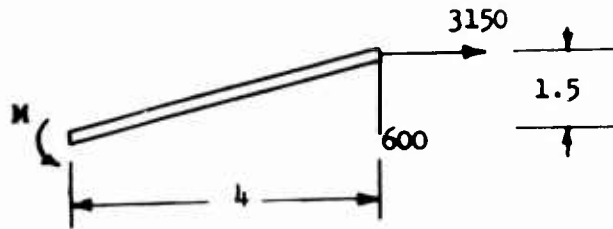

Figure 85. (U) Rocket Pod Support - Firing at 70° Elevation

Internal Strut Loads:



$$\begin{aligned}
 M &= 3,150(1.5) + 4(600) \\
 &= 4,750 + 2,400 \\
 &= 7,150 \text{ in. -lb.}
 \end{aligned}$$

$$\begin{aligned}
 P_{\text{axial}} &= 3,150 \left(\frac{4}{4.3} \right) - 600 \left(\frac{1.5}{4.3} \right) \\
 &= 2,940 - 210 \\
 &= 2,730 \text{ Tension}
 \end{aligned}$$

Moment at the Collar:

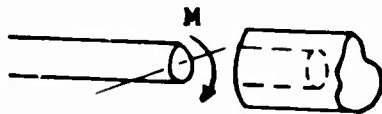

$$M = 1,800(16.5) = 29,700 \text{ in. -lb.}$$

Rocket Pod Internal Loads - Firing at 70° Elevation (Reference Figure 85)

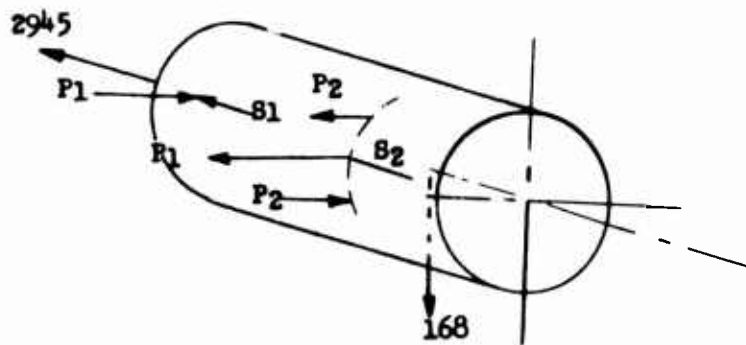

$$P_1 = 3,130(10.5)/20 = 1,645$$

Axial Load in Screw Jack = $1,645/\sin 30^\circ = 3,290$ compression

$$S_1 = 3,290 \cos 30^\circ = 2,850$$

$$S_2 = 2,850 + 3,130 = 5,980$$

$$P_2 = 230(10.5)/6 = 405$$

P_1 and S_2 are carried equally by the three struts.

Internal Strut Loads:

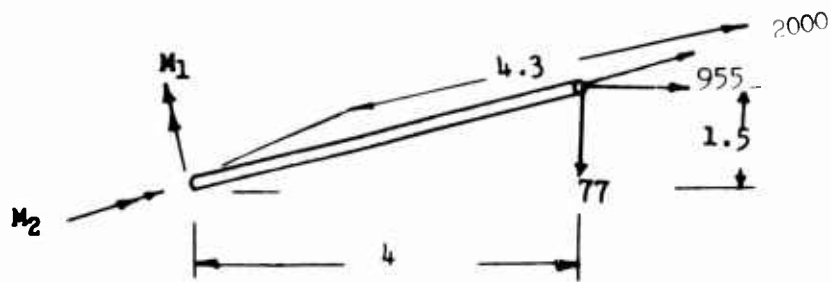

$$M_1 = 2,000(4.3) = 8,600 \text{ in. -lb.}$$

$$M_2 = 955(1.5) + 77(4) = 1,740 \text{ in. -lb.}$$

$$M_{\max} = 8,800 \text{ in. -lb.}$$

$$\begin{aligned} P_{\text{axial}} &= 955(4/4.3) - 77(1.5/4.3) \\ &= 890 - 27 \\ &= 863 \text{ lb.} \end{aligned}$$

Moments at the Collar:

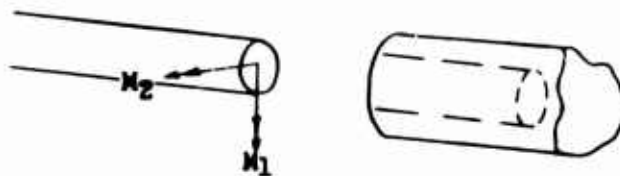

$$M_1 = 3,130(16.5) = 52,000 \text{ in. -lb.}$$

$$M_2 = 230(16.5) = 380 \text{ in. -lb.}$$

S61A Rocket Pod - Structural Analysis:

Actuator: Ultimate static load capability = 3,600 lb.

Weight 7.0 lb.

Axial load = 3,290 lb.

$$M.S. = \frac{3,600}{3,290} - 1 = +.10$$

Struts: 1.0-inch outside diameter, wall thickness 0.125

Material - 180,000 psi Heat Treated Steel

$M_{ult} = 8,800$ in.-lb.

$$I = \frac{(d_o^4 - d_i^4)}{64}$$
$$= \frac{(1.00^4 - .75^4)}{64} = .0335$$

$$f_b = \frac{8,800(.50)}{.0335} = 132,000 \text{ psi}$$

$$M.S. = \frac{180,000}{132,000} - 1 = +.36$$

Shaft: Outside diameter is 2.5 inches, Wall Thickness .188,

Material, 125-ksi Heat Treated Steel

$M_{ult} = 52,380$ in.-lb.

$$I = \frac{(2.5^4 - 2.125^4)}{64}$$
$$= .905$$

$$f_b = \frac{52,380(1.25)}{.905} = 72,500 \text{ psi}$$

$$M.S. = \frac{125,500}{72,500} - 1 = +.73$$

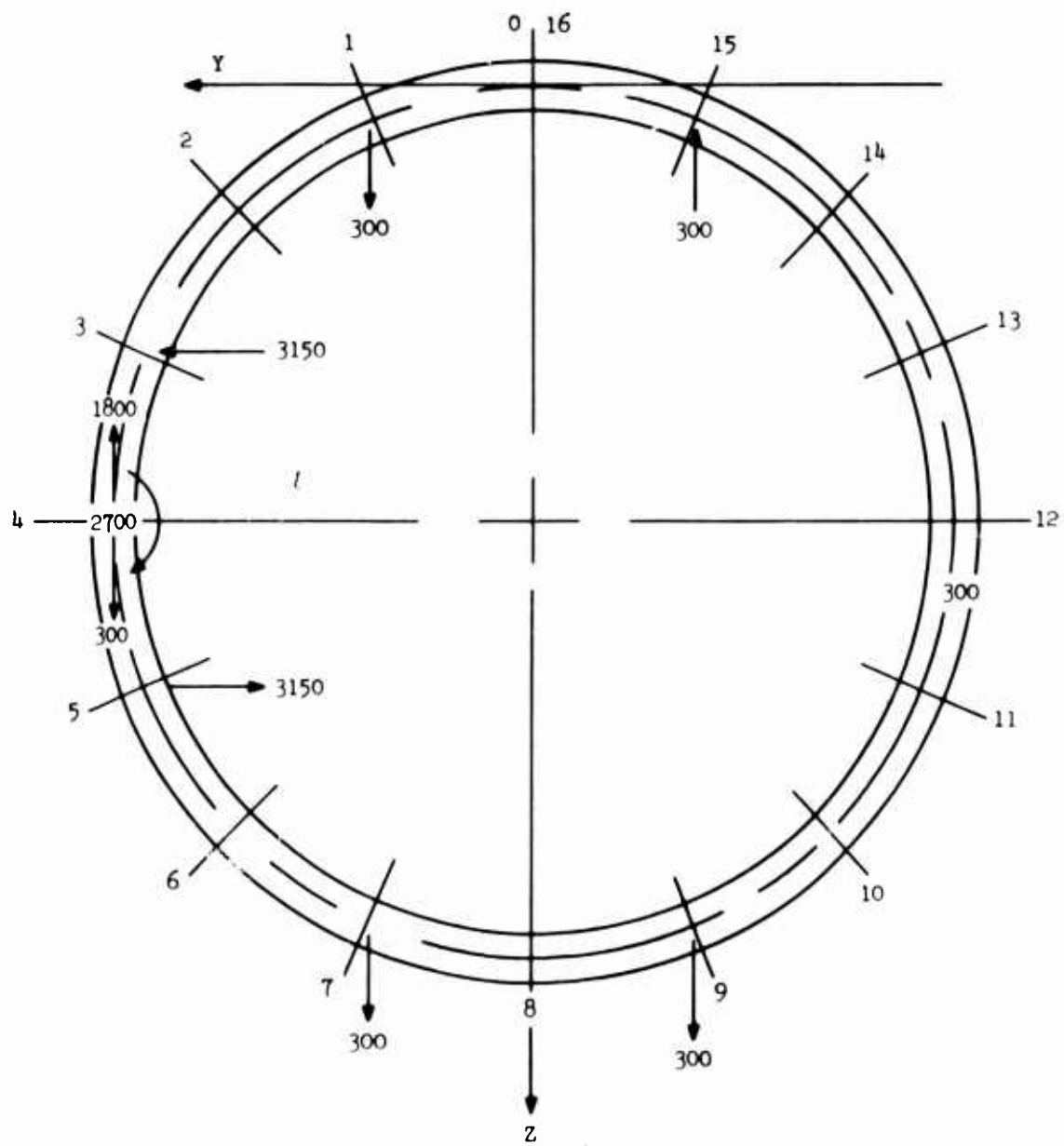

Figure 86. (U) S61A Rocket Pod Ring Loads

TABLE 36 (U)
S61A ROCKET POD
SHEARS, BENDING MOMENTS, AND AXIAL LOADS

Elem. Sta.	Moment (M)	Hor. Force (H)	Vertical Force (V)	Axial Load	Shear
0	1366.	-494.	-481.	494.	-481.
1	-578.	-511.	-778.	288.	-885.
2	-3558.	-525.	-770.	125.	-924.
3	-6431.	2615.	-759.	-2695.	391.
4	-1043.	2612.	763.	763.	-2612.
5	6771.	-535.	780.	394.	-860.
6	3862.	-525.	794.	118.	-945.
7	713.	-511.	504.	-302.	-651.
8	-1264.	-494.	507.	-494.	-507.
9	-2649.	-477.	204.	-518.	- 23.
10	-2300.	-463.	194.	-478.	154.
11	-1363.	-453.	180.	-388.	296.
12	-48.	-450.	-137.	137.	450.
13	1326.	-453.	-159.	478.	43.
14	2300.	-463.	-170.	490.	55.
15	2619.	-477.	-478.	586.	-336.
16	1366.	-494.	-481.	494.	-481.

Collar:

3.0-inch outside diameter, wall thickness .188,
Material, 180-k_{si} heat treated steel.

$$M_{ult} = 52,500 \text{ in.-lb.}$$

By comparison with the analysis of the shaft, the margin
of safety of the collar is high.

Ring: Max ring bending - 6,771 in.-lb. (Reference Table 36)

$$\frac{I}{C} = \frac{1.25(.375)^2}{6}$$

$$= .0290$$

$$f_{tu} = 180,000 \text{ psi (Reference 46)}$$

$$f_{bu} = \frac{6,771}{.029} = 233,000 \text{ psi}$$

$$M.S. = \frac{270,000}{233,000} - 1 = +.16$$

(U) APPENDIX VII

DESCRIPTION OF NAVIGATION EQUIPMENT

The following discussions are brief theories of operation of the various airborne navigation equipments which were considered:

VOR and TACAN radio navigation stations utilize isolating antennas to provide characteristic radiation patterns from which user aircraft can determine direction to the ground station. Range to the ground station is obtained by the user aircraft by measuring the propagation time of a pulse signal transmitted by the ground station in response to interrogation by the airborne transmitter. The VOR station, operating in the VHF frequency band, is normally a large permanent ground installation. This system is not a tactical system, but may be available for use in guerrilla warfare areas. TACAN, operating at UHF frequencies, is a tactical navigation system. Air transportable ground stations have been developed for use as semipermanent installations in the tactical area. Both the VOR and TACAN systems were devised primarily for long range navigation (up to 300 N. Mi.) for high-flying aircraft. Local propagation anomalies and line-of-sight considerations limit the effectiveness of the systems for low altitude operation.

Hyperbolic grid navigation systems (typified by LORAN-D, Decca, PFNS) permit determination of aircraft position by phase comparison of synchronized transmissions from a master and two slave ground stations. These systems, operating in the low frequency range, are not line-of-sight limited, but may suffer from "night effect" propagation peculiarities which tend to curtail accuracy (especially at dawn and dusk). The system locates the aircraft in a hyperbolic grid with foci at the transmitting stations. Special map conversion techniques are needed to make the system conform with conventional ground maps.

Two types of homing beacon systems are presently in use. The phase comparison type utilizes a dual antenna system to determine whether the aircraft is on the beacon. The other type uses an electric motor to rotate a null seeking directional antenna, if the antenna (aircraft) is off the bearing.

Homing beacons are operated in three frequency ranges: L. F., UHF, VHF-FM. These frequencies of operation cause the beacon to be limited to line-of-sight operation, except for operation with L. F. The principal advantage of these systems is that a minimum of airborne and ground equipment is needed. The airborne portion may consist of equipment

added to UHF or VHF-FM communication radios, and the system will home on the carrier of a ground communications radio.

The Doppler radar, inertial, and air data navigation systems are self-contained systems, and do not require any source of information external to the helicopters. The Doppler navigator measures helicopter ground speed and drift angle by means of a Doppler radar and a compass system. The velocity signals are integrated to determine the position of the helicopter. The inertial navigator doubly integrates helicopter accelerations to find position. Acceleration measurements are obtained from three orthogonally oriented accelerometers mounted on an inertially (gyro) stabilized platform.

The air data navigation system combines measured airspeed, and estimated wind information, manually entered into the computer, to obtain helicopter ground speed. The accuracy of the system is limited by the ability to know wind conditions along the flight. This type system is usually applied to very high-speed aircraft, so that wind error is only a small percentage of total flight velocity.

(U) APPENDIX VIII

PHASE I, FIRING ERROR ANALYSIS

The following is an analysis which predicts the weapon probable error radius if the fire control calculations are based on the weapon's position as determined by the navigation equipment. Figure 87 illustrates the geometry of the analysis. The error was expressed as a CPE value, since it is an easily expressed single value which represents two perpendicular probable errors.

Initial Assumptions

1. Zero base position error
2. Zero computer error
3. Zero target position error
4. Zero initial alignment error of free gyro to gyrocompass

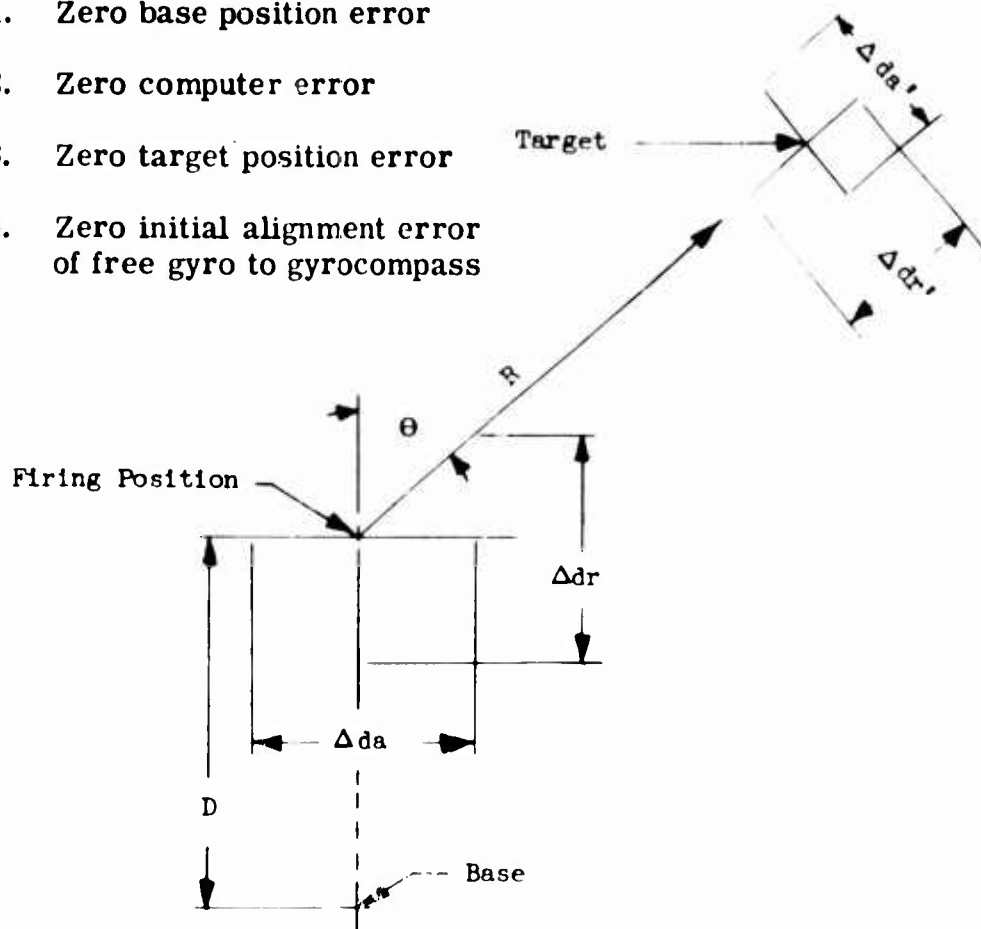

Figure 87. (U) Geometry of Firing Analysis

A circular probability curve is the result of combining the linear standard deviations (1σ) of two perpendicular errors into a circular probable error (CPE) radius. This radius means that 50% of all the errors will not exceed this value. The procedure followed in determining the CPE of the weapon fire is to find the standard deviation of the total error at the target along two perpendicular axes. Figure 87 shows these errors as Δda and Δdr . These errors are composed of a number of errors which add along common axes in the following manner:

Equation 1

$$(\Delta da)^2 = \Delta a_a^2 + \Delta b_a^2 + \Delta c_a^2 + \dots$$

(all values are 1σ , i. e., standard deviations)

The magnitudes of Δda , Δdr , and their relative magnitudes fix the CPE value.

Figure 83 shows the position errors of a Doppler navigator as a function of the initial heading error. The two curves represent errors for aircraft speeds of 100 and 150 knots at a 20-nautical-mile range. The Δda and Δdr values in the following data are the two components of the CPE values of Figure 88.

Symbols:

- Δda - Firing position azimuth error
- Δdr - Firing position range error
- Δda^1 - Total azimuth firing error at target
- Δdr^1 - Total range firing error at target
- R - Firing range
- $\Delta \theta$ - Direction reference error
- $\Delta \theta_j$ - Initial direction reference error due to truth North system
- $\Delta \dot{\theta}$ - Drift rate of reference direction
- t - Flight time from base to firing position
- ΔWa - Artillery azimuth error
- ΔWr - Artillery range error
- ΔA - Altitude error
- V - Aircraft velocity
- D - Aircraft range

Figure 87 shows that Equation 1 is a function of the target-firing point line relative to the base-firing point line (i. e., $\angle \theta$). The following equations were used to describe the total standard deviation errors at the target.

Equation 2

$$(\Delta da^1)^2 = (\Delta da \cos \theta)^2 + (\Delta dr \sin \theta)^2 + (R \cdot \Delta \theta)^2 + (\Delta Wa)^2.$$

Equation 3

$$(\Delta dr^1)^2 = (\Delta da \sin \theta)^2 + (\Delta dr \cos \theta)^2 + (\Delta Wr)^2 + (\Delta A)^2.$$

Where

$$\theta = \Delta \theta_j + \Delta \theta_t,$$

$$t = D/V.$$

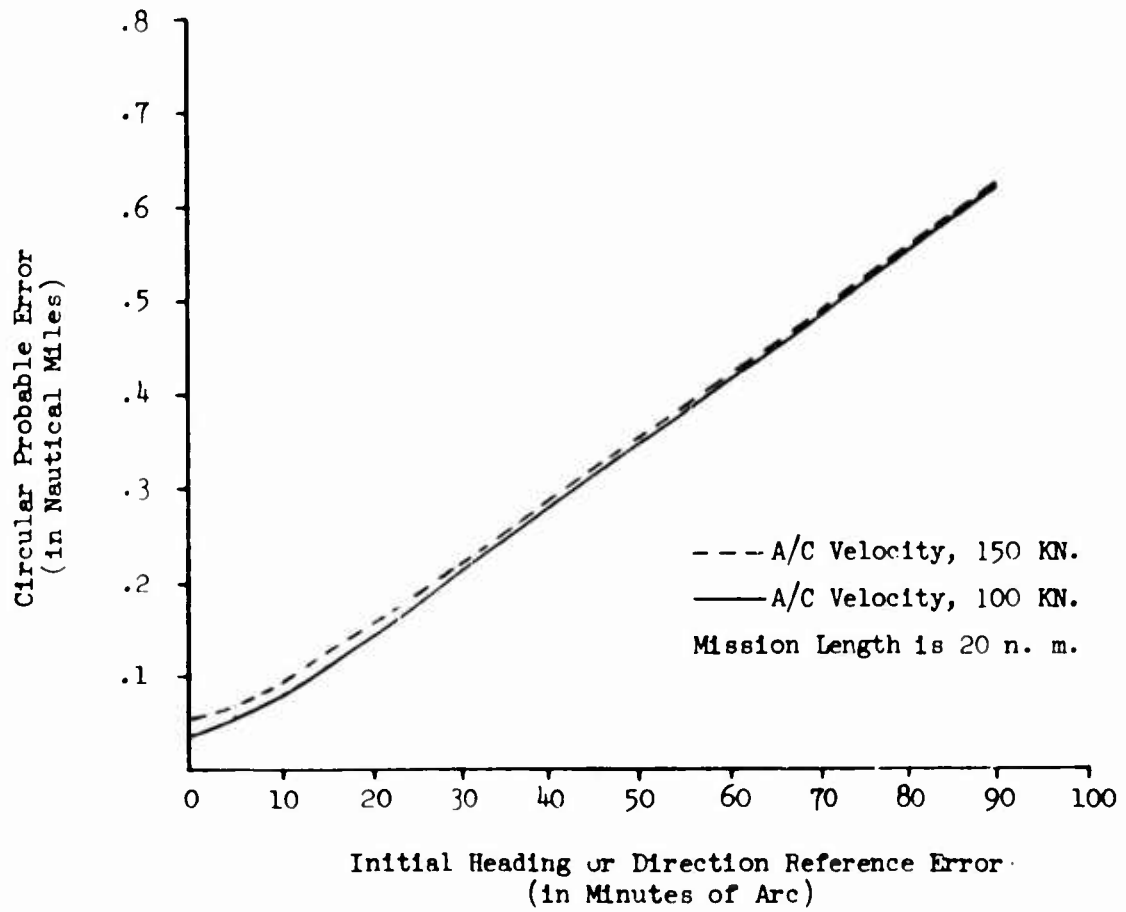

Figure 88. (U) Doppler Navigation Error

Firing Analysis Resultant Data:

TABLE 37 (U)
CPE FIRING ERROR

()	105-mm. Howitzer Chg. #7 (Reference d)		Little John (Reference e)	
	100 kn.	150 kn.	100 kn.	150 kn.
0°	83.85 yd.	115.5 yd.	252.3 yd.	263.2 yd.
30°	94.26 yd.	116.2 yd.	254.3 yd.	263.1 yd.
60°	94.57 yd.	116.2 yd.	258.2 yd.	264.8 yd.
90°	85.6 yd.	115.7 yd.	258.2 yd.	264.0 yd.

Initial Analysis Data: (all values are 1σ)

1. Doppler Position Error with 3.4 min. of Arc
2. Initial Reference Error (from Graph #4)

D = 20 n. mi.

V = 100 kn. + 150 kn.

$\Delta da = .01413$ n. mi. $\left\{ \begin{array}{l} \text{at 100 kn.} \\ \text{at 150 kn.} \end{array} \right.$
 $\left. \begin{array}{l} .0442 \text{ n. mi.} \\ .0508 \text{ n. mi.} \end{array} \right\}$

3. Weapon Errors:

105-mm. Howitzer Chg. #7

R = 8,752 yd. (8,000m.)
 $\Delta Wa = 8.12$ yd.
 $\Delta Wr = 24.35$ yd.

Little John

R = 16,000 yd.
 $\Delta Wa = 168.8$ yd.
 $\Delta Wr = 233.8$ yd.

4. Other Errors:

$$\begin{aligned} \Delta A &= 1 \text{ foot} \\ \Delta \theta_j &= 9.86 \times 10^{-4} \text{ rad.} \\ \Delta \dot{\theta} &= .25^\circ/\text{hr} \\ t &= .2 \text{ hr. (at 100 kn.)} \\ t &= .133 \text{ hr. (at 150 kn.)} \end{aligned}$$

5. Firing Errors of Weapons: (Derived from tables found in Reference 64)

105-mm. Howitzer Charge #7 at 8,752 yd. (8000m.)

$$\text{CPE} = 18.8 \text{ yd.}$$

Little John at 16,000 yd.

$$\text{CPE} = 236 \text{ yd.}$$

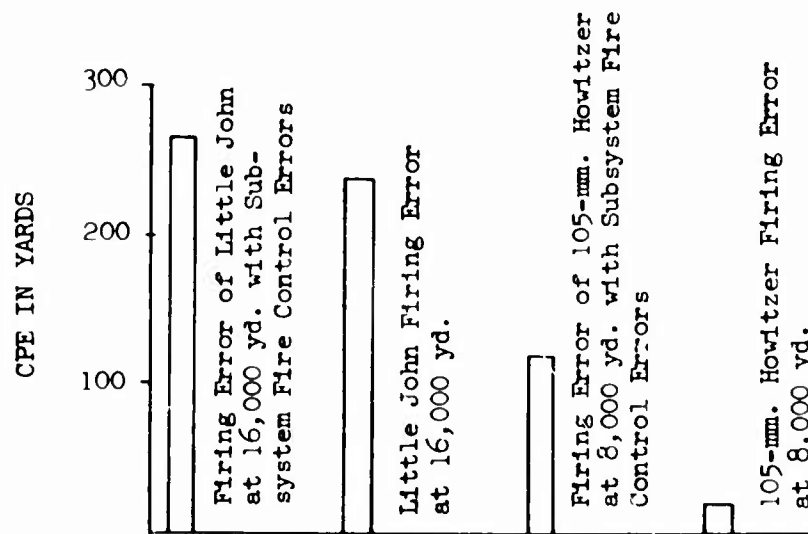

Figure 89. (U) Subsystem Firing Errors vs. Weapon Firing Error

(U) APPENDIX IX

PHASE I, NAVIGATION AND FIRE CONTROL SUBSYSTEM

	Weight
Communications	
HF/SSB Transceiver	72.5 lb.
Intercommunications	5 lb.
Navigation	
Doppler Radar	35 lb.
Heading and Attitude Reference System	52.3 lb.
Navigation Computer	28 lb.
Fire Control	
Computer	135 lb.
Miscellaneous Sensors	
Air Temperature X-ducer	
Air Density Computer	20 lb.
Wind Velocity and Direction	
Propellant Temperature	
	<hr/>
	342.8 lb.

Note: Total weight does not include wiring or mountings.

(U) APPENDIX X

TIME REQUIRED TO DISPLACE VTOL AIRMOBILE ARTILLERY
AIRCRAFT - PHASE II, 1970-1980

The assumptions shown in Table 38 were used in developing the mission times required for various VTOL aircraft concepts as airmobile artillery air vehicles in the 1970-1980 time period. These values are based on Sikorsky flight simulator studies and estimates of performance penalties due to the added drag and complexity of an artillery weapons installation.

A constant estimated time penalty was assumed for necessary ground firing operations from engine stop to start and including positioning of wings or propellers if required. A constant flight altitude was assumed. The values shown are estimated averages. Actual practice would vary based on length of mission, closeness to the FEBA, and pilot preferences.

It was assumed that the climb to and from flight altitude occurred during acceleration and deceleration from cruise speed. An average climb gradient of 45° was assumed and the total time and resultant (mission) distances covered during these maneuvers are shown as constants. Basic acceleration equations of $v = u + at$ and $s = ut + 1/2 at^2$ were used.

TABLE 38 (U)

	Helicopter	Compound Helicopter	Tilt-Type Aircraft
V_{cr} , kn.	150	225	300
Acceleration & Deceleration Kn./sec ²	3.0	4.0	5.0
(1) Takeoff & Landing, min.	3.0	3.0	3.0
Flight Altitude, ft.	200	300	600
(2) Total Accelerating & Decelerating			
Time, min.	1.67	1.87	2.0
Distance, n. miles	2.06	3.49	4.92
(1) Estimated times for ground operation, (rotor start, etc.) from engine start to stop.			
(2) Total time and later distance covered between ground and flight altitude.			

Having established basic constants in time and distance that are applicable to any mission length, the remaining distance and time were simply calculated at the estimated V_{cr} . The results are shown in Table 39.

TABLE 39 (U)

VTOL AIRCRAFT DISPLACEMENT TIME

	Helicopter	Compound Helicopter	Tilt-Type Aircraft
Basic Constants	4.67	4.87	5.0
Total Time, min.	2.06	3.49	4.92
Distance, n. mi.			
	Total Required Time, min.		
Mission, mi.			
5	5.85	5.27	5.02
10	7.85	6.61	6.02
15	9.85	7.94	7.02
20	11.85	9.28	8.02
30	15.85	11.95	10.02
40	19.85	14.62	12.02
50	23.85	17.29	14.02

(U) APPENDIX XI

COST COMPARISON - VTOL AIRCRAFT

PHASE II, 1970-1980

Estimates were made for the cost of the aircraft shown in Table 17. These are shown in Table 40 and are expressed in terms of a procurement of 100 aircraft. The breakdown of costs for maintenance labor and material is shown in Table 41. The total cost of operation per flight hour is shown in Table 42.

The operational costs were used with the mission times for the aircraft shown in Appendix XI to develop costs for the various length missions shown in Table 43. These costs were modified to show the effect of some attrition rates. Changes in attrition rates affect costs but do not significantly change the cost ratios between the different aircraft. All costs shown are representative of the costs trends as they are based on estimates of theoretical aircraft.

TABLE 40 (U)
PROCUREMENT COSTS

	Helicopter	Compound Helicopter	Tilt-Type Aircraft
Total Dynamic Components	\$ 204,000	\$ 297,000	\$ 284,000
Lift Rotor Cost	(125,000)	(144,000)	(70,000)
Prop/Tail Rotor Cost	(16,000)	(67,000)	0
Transmission Cost	(63,000)	(186,000)	(214,000)
Static Airframe	496,000	647,000	846,000
Total Airframe	700,000	940,000	1,130,000
Engines	200,000	200,000	330,000
Electronics	80,000	80,000	80,000
Total Aircraft (1), (2)	980,000	1,220,000	1,540,000
RDT & E (3)	\$ 40,000,000	\$ 50,000,000	\$ 70,000,000

(1) Total aircraft cost is based on the procurement of 100 aircraft.

(2) Total aircraft cost does not include the additional cost for the special equipment (fire direction center, weapons, and their installation) that would be associated with an airmobile artillery aircraft.

(3) RDT & E - Research, Development, Test, and Evaluation

TABLE 41 (U)

ESTIMATED MAINTENANCE LABOR AND MATERIAL COST

	Helicopter	Compound Helicopter	Tilt-Type Aircraft
Total Labor, \$/F. H.	\$ 35.1	\$ 47.1	\$ 44.7
Total Labor, M. H. /F. H.	11.7	15.7	14.9
Airframe	(3.5)	(3.6)	(3.7)
Airframe, Overhaul	(.8)	(.8)	(.8)
Dynamic System	(3.2)	(4.3)	(3.5)
Dynamic System, Overhaul	(3.8)	(7.0)	(6.9)
Total Materials, \$/F. H.	23.0	41.0	45.0
Airframe	(9.0)	(10.0)	(11.0)
Transmission	(16.0)	(18.0)	(21.0)
Rotor & Props	(8.0)	(13.0)	(13.0)
Engine Maintenance, \$/F. H.	\$ 21.0	\$ 21.0	\$ 34.0

- NOTES: 1. \$/F. H. - Cost per flight hour
2. M. H. /F. H. - Man-hours per flight hour
3. Maintenance man-hours, \$3.00 per hour
4. Overhaul assumed at 1000 flight hours

TABLE 42 (U)

ESTIMATED OPERATIONAL COSTS PER FLIGHT HOUR

	Helicopter	Compound Helicopter	Tilt-Type Aircraft
Amortization	\$ 226.85	\$ 282.41	\$ 356.48
Maintenance Man-Hours	35.10	47.10	44.70
Maintenance Materials	23.00	41.00	45.00
Engine Maintenance	21.00	21.00	34.00
Fuel	65.00	86.00	104.00
RDT & E	92.59	115.74	162.04
TOTAL	\$ 463.54	\$ 593.25	\$ 746.22
Attrition Adjustments			
Peacetime - .006 Per Year	13.16	16.94	21.39
Combat - .05	62.82	78.20	98.72
.10	125.64	156.41	197.44
.20	251.29	312.82	394.87

- NOTES: 1. Amortization is based on a 10-year aircraft life at 36 flight hours per month.
2. Fuel is estimated at \$.12 per gal. or \$.02 per pound.
3. Attrition costs = $\frac{\text{Procurement Cost} \times \text{Attrition Rate}}{\text{Flight Hours Per Year}}$
4. Flight hours per year are assumed at:
 Peacetime - 432
 Combat - 780 (Ref. Page 119, 2.16 hrs. max. average flight time per day)

TABLE 43 (U)

ESTIMATED OPERATIONAL COST PER MISSION

	(Mission Radius)			
	5 N. Mi	10 N. Mi.	20 N. Mi.	50 N. Mi.
Attrition Rate-.006 (Peacetime)				
Helicopter	\$ 46.52	\$ 62.43	\$ 94.24	\$ 189.67
Compound Helicopter	53.90	67.22	94.38	175.84
Tilt-Type Aircraft	64.22	77.01	102.60	179.36
Attrition Rate-.05 (Combat)				
Helicopter	\$ 51.32	\$ 68.86	\$ 103.96	\$ 209.23
Compound Helicopter	59.29	73.97	103.85	193.49
Tilt-Type Aircraft	70.69	84.77	112.93	197.43
Attrition Rate-.10 (Combat)				
Helicopter	\$ 57.45	\$ 77.08	\$ 116.36	\$ 234.20
Compound Helicopter	66.19	82.59	115.95	216.03
Tilt-Type Aircraft	78.95	94.68	126.13	220.50
Attrition Rate-.20 (Combat)				
Helicopter	\$ 69.70	\$ 93.52	\$ 141.18	\$ 284.14
Compound Helicopter	80.01	99.82	140.14	261.10
Tilt-Type Aircraft	95.46	114.84	152.52	266.63

NOTES: 1. Cost per Mission = Cost per Flight Hour x Mission Time

2. Cost per Flight Hour = Total Operational Cost plus
Attrition Adjustment

(C) APPENDIX XII (U)

WEIGHT AND BALANCE - PHASE II (1970-1980) (U)

(U) INTRODUCTION

This section presents weight and balance information for the two aircraft configurations selected for the airmobile artillery concept following a parametric study. The primary aircraft is shown by Figure 40 and Figure 41. The alternate aircraft is shown by Figure 42.

The weights of these aircraft were determined by using Sikorsky-developed weight trend curves for those items whose weights are dependent on major design parameters and by use of estimated weights consistent with Sikorsky design experience for items whose weight is dependent on choice of power plant or on mission requirements.

(U) ABSTRACT

(U) Weight and Balance Summary - Primary Aircraft

<u>Item</u>	<u>Weight (Lb)</u>	<u>Sta.</u>	<u>WL</u>	<u>*BL</u>
Weight Empty	15,896	316.9	242.2	+1.1
Gross Weight - Burst-Fire Howitzer	28,017	305.5	216.2	+6.8
Gross Weight - 155-mm. Gun-Boost Rocket	27,918	304.0	216.2	+8.8

* port side (+)

The aircraft center of gravity throughout the normal operating conditions is within the allowable limits normally recommended for aircraft of this type and size.

(U) Weight and Balance Summary - Alternate Aircraft

<u>Item</u>	<u>Weight (Lb)</u>	<u>Sta.</u>	<u>WL</u>	<u>*BL</u>
Weight Empty	13,308	277.6	237.2	+0.5
Gross Weight	22,725	296.9	210.8	+0.5

* port side (+)

The aircraft center of gravity throughout the normal operating conditions is within the allowable limits normally recommended for aircraft of this type and size.

(C) WEIGHT DERIVATION (U)

(U) Main Rotor Group

The weight of the rotor group is determined by the use of the following equations:

$$W_b = 1.092 (RC)^{1.36}$$

$$W_{rg} = 1.69 (W_b)^{0.95} (b)^{1.27}$$

where:

W_b = weight of a single main rotor blade - lb.

R = main rotor radius - ft.

C = main rotor blade chord - ft.

W_{rg} = weight of the main rotor group - lb.

b = number of main rotor blades

Special design features such as automatic blade positioning or locating and fairings must be added to the formula results as weight increments.

The use of titanium in the rotor head and for blade cuffs has resulted in appreciable weight savings in the latest Sikorsky models, the CH-53A and CH-3C. Equivalent titanium components are assumed in these configurations and so give rise to weight decrements.

For the primary aircraft:

$R = 30$ ft.

$C = 2.167$ ft.

$b = 6$

Blade Weight	<u>306 lb.</u>
Formula weight	319
Titanium savings	-13

Rotor Group Weight		<u>3,555 lb.</u>
Formula weight		<u>3,780</u>
Weight increments		-225
Automatic blade positioning	+142	
Titanium savings	-375	
Fairing	+ 8	

For the alternate aircraft:

$$R = 27 \text{ ft.}$$

$$C = 2.167 \text{ ft.}$$

$$b = 5$$

Blade Weight		<u>265 lb.</u>
Formula weight		<u>276</u>
Titanium savings		-11

Rotor Group Weight		<u>2,416 lb.</u>
Formula weight		<u>2,616</u>
Weight increments		-200
Automatic blade locating	+ 30	
Titanium savings	-238	
Fairing	+ 8	

(U) Tail Group

The tail group weight is taken as 1.3 percent of design gross weight. This is a conservative value for existing helicopters of this size.

$$W_{tg} = 0.013 \text{ (DGW)}$$

For the primary aircraft:

$$W_{tg} = (0.013) (28,213) \quad \underline{365 \text{ lb.}}$$

For the alternate aircraft:

$$W_{tg} = (0.013) (22,725) \quad \underline{300 \text{ lb.}}$$

(U) Body Group

The weight of the body group is given by:

$$W_b = 0.587 (DGW)^{0.355} (A_w)^{0.643} + \text{special design features}$$

where:

W_b = basic body group weight - lb.

DGW = design gross weight - lb.

A_w = wetted area - sq. ft.

For the primary aircraft:

DGW = 28,213 lb.

A_w = 936 sq. ft.

Body Group Weight		<u>3,210 lb.</u>
Formula weight		1,816
Special design features		+1,394
Pods	814	
Blast	260	
Glass	25	
Service platforms	20	
Doghouse	170	
Landing gear support	105	

For the alternate aircraft:

DGW = 22,725 lb.

A_w = 940 sq. ft.

Body Group Weight		<u>2,456 lb.</u>
Formula weight		1,686
Special design features		+770
Blast	150	
Floor	45	
Cabin doors	50	
Glass	25	
Service platforms	20	
Doghouse	170	
Landing gear support	310	

(U) Alighting Gear Group

The weight of the alighting gear is assumed to be 3.5 percent of gross weight. This is consistent with current nonretractable landing gear for helicopters.

$$W_{alg} = 0.035 \text{ DGW}$$

For the primary aircraft:

$$W_{alg} = (0.035) (28,213) \quad \underline{980 \text{ lb.}}$$

For the alternate aircraft:

$$W_{alg} = (0.035) (22,725) \quad \underline{805 \text{ lb.}}$$

(U) Flight Controls Group

The weight of the flight controls, including automatic stabilization equipment, is expressed as:

$$W_{fc} = 0.10 (\text{DGW})^{0.89}$$

For the primary aircraft:

$$W_{fc} = 0.10 (28,213)^{0.89} \quad \underline{923 \text{ lb.}}$$

For the alternate aircraft:

$$W_{fc} = 0.10 (22,725)^{0.89} \quad \underline{753 \text{ lb.}}$$

(U) Drive System

The weight of the drive system is given by the following equations:

$$W_{mgb} = 0.0145 (Q)^{0.792} (M)^{0.146}$$

$$W_{ds} = 1.58 W_{mgb}$$

where:

W_{ds} = weight of the drive system - lb.

W_{mgb} = weight of the main gearbox - lb.

Q = torque based on maximum gearbox HP and main rotor RPM - in. -lb.

M = main gearbox reduction ratio

(U) For the primary aircraft:

Drive System Weight		<u>2,901 lb.</u>
Main gearbox weight	1,836	
$Q = 1,492,251$ in. -lb.		
$M = 28.7$		

(U) For the alternate aircraft:

Drive System Weight		<u>2,626 lb.</u>
Main gearbox weight	1,662	
$Q = 1,341,800$ in. -lb.		
$M = 25.5$		

The remaining weight empty items are estimated by comparison with existing Sikorsky helicopters of similar size and configuration. Their weights are shown in the group weight statement.

TABLE 44 (U)

GROUP WEIGHT STATEMENT, PHASE II AIRCRAFT

Item	Primary Aircraft	Alternate Aircraft
Rotor Group	3,555	2,416
Blades (6)(5)	1,836	1,325
Head & Hub	1,569	1,053
Blade Positioning or Locating	142	30
Fairing	8	8
Tail Group	365	300
Tail Rotor	275	220
Stabilizer	90	80
Body Group	3,210	2,456
Alighting Gear	980	805
Flight Controls	923	753
Engine Section	220	220
Propulsion Group	4,627	4,352
Engine Installation	1,286	1,286
Air Induction	30	30
Exhaust System	30	30
Lubricating System (Integral with Engine)		
Fuel System	265	265
Engine Controls	35	35
Starting System	80	80
Drive System	2,901	2,626
Auxiliary Power Plant	170	170
Instruments and Navigation	550	550
Instruments	200	200
Navigation	350	350
Hydraulic	85	85
Electrical	525	500
Electronics	200	200
Fire Control System	81	81
Furnishings and Equipment	255	270
Air Cond. and Anti-Ice	135	135
Auxiliary Gear	15	15
WEIGHT EMPTY	15,896	13,308

CONFIDENTIAL

(C) TABLE 45

MISSION LOADINGS - PRIMARY AIRCRAFT (U)

Item	Weight	
	Burst-Fire Howitzer	155-MM. Gun- Boost Rocket
WEIGHT EMPTY	15,896	15,896
USEFUL LOAD	12,121	12,022
Pilot & Copilot	400	400
Gun Crew (3)	600	600
Fuel - Usable (396.2 gal) JP-4	2,575	2,575
- Unusable (0.3 gal) JP-4	2	2
Oil - Engine (1.9 gal)	14	14
- Unusable (2.1 gal)	16	16
Fire Control Equipment	340	240
Misc. Tools & Equipment	280	100
Weapon Platform	1,731	1,731
Weapon	2,500	3,430
Ammunition	2,520	1,680
Ammunition Racks	500	576
Track Installation	135	150
Hoist	50	50
4-Point Winch	380	380
Winch Controls	5	5
Seats (Crew)	18	18
Seat Cushions (Pilot, Copilot)	5	5
Canvas Fairing	50	50
GROSS WEIGHT	28,017	27,918

CONFIDENTIAL

(C) TABLE 46

MISSION LOADINGS - ALTERNATE AIRCRAFT (U)

Item	Weight
WEIGHT EMPTY	13,308
USEFUL LOAD	9,417
Pilot & Copilot	400
Gun Crew (3)	600
Fuel - Usable (344.8 gal) JP-4	2,241
- Unusable (0.3 gal) JP-4	2
Oil - Engine (1.9 gal)	14
- Unusable (2.1 gal)	16
Seats (Crew)	18
Fire Control Equipment	240
Misc. Tools & Equipment	100
105-MM. Gun-Boost Rocket	1,755
Ammunition	3,540
Ammunition Racks	486
Seat Cushions	5
GROSS WEIGHT	22,725

CONFIDENTIAL

(C) APPENDIX XIII (U)

PHASE II, STRUCTURAL ANALYSIS (U)

(C) PHASE II, STRUCTURAL PENALTIES TO PRIMARY AIRCRAFT WITH 105-MM. BURST-FIRE HOWITZER (U)

(C) The blast overpressures produced by the firing of the 105-mm. burst-fire howitzer are considered to have the same magnitude and distribution as the normal 105-mm. howitzer. The elevation at which the fuselage is subjected to the maximum pressures is 70°. The average limit overpressure on the left side of the fuselage is 3.56 psi, and the maximum is 4.5 psi (Reference Figure 49).

(U) The blast pressures on the YCH-54A fuselage due to the 105-mm. howitzer are as follows (Reference Table 34):

Average limit overpressure (near side): 8.98 psi
Maximum limit overpressure (near side): 14.0 psi

(U) Structural Penalties Due to Overpressures:

(U) There will be no structural problems in the fuselage skin. The analysis made on the YCH-54A indicated that the fuselage skin could withstand a limit overpressure of 7.0 psi in fatigue with a margin of safety of 0.455. Therefore the maximum limit overpressure of 4.5 psi will cause no structural problem in the Phase II aircraft skin.

The weight penalty to the fuselage frames and stringers will be determined as follows:

(U) P_1 = Average limit overpressure on YCH-54A

(U) P_2 = Average limit overpressure, Phase II Primary Aircraft

(U) W_1 = Weight of beef-up to YCH-54A fuselage frames & stringers

(U) W_2 = Weight Penalty to be assessed to Phase II primary aircraft estimated gross weight

$$\frac{P_1}{P_2} = \frac{W_1}{W_2}$$

CONFIDENTIAL

$$W_2 = \frac{P_2}{P_1} W_1$$

$$W_2 = \frac{3.56}{8.98} W_1 = .40 W_1$$

(U) The YCH-54A gun crew pod and ammunition pod were vented so that any blast overpressures would have no net effect on their structure. Venting is not feasible on the Phase II primary aircraft, since the pods are made integral with the fuselage for aerodynamic purposes. The pod areas will be subjected to an average limit overpressure of 2.2 psi which would damage the frames and stringers. The weight penalty to be assessed in this area is determined as follows:

W_3 = Total weight of YCH-54A gun crew pod and ammunition pod frames and stringers

W_2 = Weight penalty to be assessed, in pod areas, to Phase II primary aircraft estimated gross weight

$$\begin{aligned} W_2 + W'_2 &= .40 W_1 + .40 W_3 \\ &= .40 (W_1 + W_3) \end{aligned}$$

(C) Firing Platform for 105-mm. Burst-Fire Howitzer (U)

(C) The recoil force of the burst fire and the normal 105-mm. howitzers are to be considered the same. The overall dimensions of both platforms are approximately the same also. It is therefore reasonable to assume the 105-mm. burst-fire howitzer firing platform should have the same weight as the Phase I 105-mm. howitzer firing platform.

(U) Rotor Blades on Primary Aircraft With 105-mm. Burst-Fire Howitzer

It should be assumed that the response of these blades will not be any less than that of the YCH-54A blades. Blade positioning was required on the YCH-54A and will be required on the Phase II primary aircraft.

CONFIDENTIAL

(C) PHASE II STRUCTURAL PENALTIES TO PRIMARY AIRCRAFT WITH 155-MM GUN-BOOSTED ROCKET (U)

(C) The firing forces are due solely to the gun-boost propellant and are expected to be in the magnitude of zone 1 charge. The recoil force is to be considered approximately 28,000 lb. The blast overpressures behind the muzzle are to be considered equivalent to maximum M30 mortar valves. It should be noted that the blast overpressures due to rocket exhaust have not been considered since no information is available at present. The following analysis should, therefore, be considered preliminary pending further testing to determine the rocket blast pressures.

(C) Fuselage and Pod Modifications: (U)

No further modifications are required beyond those which will be required for the 105-mm. burst-fire howitzer. The limit overpressures due to the M30 mortar are 1.0 to 2.0 psi. These pressures are less than the fuselage will encounter during the firing of the 105-mm. burst-fire howitzer.

(U) Rotor Blades:

The requirement for a blade positioning system has been established in the analysis for the 105-mm. burst-fire howitzer. It will therefore be assumed that the blades are positioned for this weapon also. No further analysis is required on the blades.

(C) Firing Platform: (U)

(U) R_1 = Recoil force, 105-mm. howitzer

(C) R_2 = Recoil force, 155-mm. gun-boosted rocket

(U) W_1 = Weight of 105-mm. howitzer firing platform

(U) W_2 = Weight of 155-mm. gun-boosted rocket firing platform

$$(U) \frac{R_1}{R_2} = \frac{W_1}{W_2}$$

$$(C) \frac{27,900}{28,000} = \frac{W_1}{W_2}$$

$$(U) W_2 = W_1$$

CONFIDENTIAL

(C) PHASE II, STRUCTURAL PENALTIES TO ALTERNATE AIRCRAFT, 105-MM. GUN-BOOSTED ROCKET (U)

(C) The blast overpressures are considered to be those resulting from an M30 motor. It should be stressed that no information is available in the following areas:

- (a) Blast pressure in front of the muzzle due to zone 1 charge booster.
- (b) Rocket blast overpressures.

(C) The recoil force is estimated by reducing the recoil of the 155-mm. gun-boosted rocket by the ratio $(105/155)^2$.

(C) The following are the estimated blast forces based on the available data.

- (a) Recoil Force = $3 (105/155)^2 4,700 = 6,500$ lb.
- (b) Average limit overpressure = 1.5 psi

(U) Structural Penalties to Fuselage:

P_2 = Average limit overpressure on Phase II primary aircraft due to 105-mm. burst-fire howitzer

P_2^1 = Average limit overpressure on Phase II alternate aircraft due to 105-mm. burst fire

W_2 = Weight penalty to Phase II primary aircraft fuselage and pods (Reference p. 396)

W_2^1 = Weight penalty to Phase II alternate aircraft fuselage estimated gross weight

$$\frac{P_2}{P_2^1} = \frac{W_2}{W_2^1}$$

$$\begin{aligned} W_2^1 &= \frac{1.5}{3.56} W_2 \\ &= .42 W_2 \end{aligned}$$

CONFIDENTIAL

(C) Estimated Weight of 105-mm. Gun-Boosted Rocket Pod Weapon Mount: (U)

(U) R_1 = Recoil force of 4.5-in. rocket cluster on S61-A
(Reference p. 358)

(C) R_2 = Recoil force of 105-mm. gun-boosted rocket

(U) W_1 = Total weight of 4.5-in. rocket pod mounts on S61-A

(U) W_2 = Total weight of both 105-mm. gun-boosted rocket mounts

$$(U) \frac{R_1}{R_2} = \frac{W_1}{W_2}$$

$$(C) W_2 = \frac{6,500}{1,675} (W_1) \\ = 3.90 W_1$$

(U) Rotor Blades:

There is insufficient data available for a determination of the blast loads on the main rotor blades. It will therefore be assumed, pending further testing, that no blade positioning system will be required.

(U) APPENDIX XIV

PHASE II, NAVIGATION AND FIRE CONTROL SUBSYSTEM

	<u>Weight</u>
Navigation	
Loran-D Receiver	20 lb.
Coordinate Converter for Loran-D	15 lb.
Airborne Gyrocompass	40 lb.
* Navigation Computer	30 lb.
Auxiliary Flight Aids	
Terrain Avoidance Radar	80 lb.
Terrain Display	40 lb.
Short Range Stationkeeping	40 lb.
Fire Control	
* Fire Control Computer	35 lb.
Miscellaneous Equipments	
Wind Velocity and Direction Sensor	
Air Temperature X-sensor	25 lb.
* Air Density Computer	
Propellant Temperature Sensor	
Computer-Weapon Servo Amplifier	2 lb.
Communications	
Data Link Transceiver	22 lb.
Encoder & Decoder	
HF/SSB Transceiver	37 lb.
Intercommunications	2 lb.

* Possibly one computer will perform both computations but at different times.

(U) APPENDIX XV

PHASE II, FIRING ERROR ANALYSIS

The following analysis was performed to determine the cumulative weapon aiming errors caused by errors in meteorological measurements and position locating. Data used in this analysis are for a 105-mm. howitzer firing a number 7 charge (Reference 16).

Symbols:

Δda	=	cumulative azimuth error
Δdr	=	cumulative range error
ΔAw	=	weapon's lateral position error
ΔRw	=	weapon's longitudinal position error
ΔAt	=	target position error along weapon's lateral axis
ΔRt	=	target position error along weapon's longitudinal axis
Wa	=	error due to crosswind measurement error
Mr	=	error along range due to measurement errors which affect muzzle velocity
Wr	=	error along range due to wind measurement error
Tr	=	error along range due to air temperature measurement error
Dr	=	error along range due to air density calculation error
Ha	=	azimuth error due to direction reference error
R	=	weapon firing range

Assumptions:

The following are the assumed measurement errors:

1. Weapon and target position error 10m CPE.
2. Direction reference error - 2 minutes of arc (1σ)
3. Wind measurement error along and cross range - 6 kn. (3σ)
4. Air temperature and density error - 1% (3σ)
5. Muzzle velocity error - 1 ft./sec. (3σ)

Analysis data based on previous assumptions:

(All values are 1σ)

$$\begin{aligned}
 \Delta Aw &= 8.5 \text{ m} \\
 \Delta Rw &= 8.5 \text{ m} \\
 \Delta At &= 8.5 \text{ m} \\
 \Delta Rt &= 8.5 \text{ m} \\
 Wa &= 1.1 \text{ mil.} \\
 Wr &= 24 \text{ m} \\
 Mr &= 2 \text{ m} \\
 Tr &= 7 \text{ m} \\
 Dr &= 8 \text{ m} \\
 Ha &= 5.8 \times 15^4 \text{ rad.} \\
 R &= 8000 \text{ m}
 \end{aligned}$$

Cumulative aiming error equations:

$$\begin{aligned}
 (\Delta da)^2 &= (\Delta Aw)^2 + (\Delta At)^2 + (R \times H^2)^2 + (R \times Wa)^2 \\
 (\Delta dr)^2 &= (\Delta Rw)^2 + (\Delta Rt)^2 + (Mr)^2 + (Wr)^2 + (Tr)^2 + (Dr)^2 \\
 da &= 9.95 \text{ m} \\
 dr &= 29 \text{ m}
 \end{aligned}
 \left. \vphantom{\begin{aligned} da \\ dr \end{aligned}} \right\} \text{CPE} = 26.04 \text{ m}$$

Firing errors due only to meteorological and projectile parameter measurement errors.

$$\begin{aligned}
 (\Delta da^1)^2 &= (R \times Wa)^2 \\
 (\Delta dr^1)^2 &= (Mr)^2 + (Wr)^2 + (Tr)^2 + (Dr)^2 \\
 \Delta da^1 &= 8.775 \text{ m} \\
 \Delta dr^1 &= 26.55 \text{ m}
 \end{aligned}
 \left. \vphantom{\begin{aligned} \Delta da^1 \\ \Delta dr^1 \end{aligned}} \right\} \text{CPE} = 20.35 \text{ m}$$

The normal firing distribution of the 105-mm. howitzer at 8,000 meters with a No. 7 charge has a CPE of 17.2 meters. The total cumulative firing error was found to be substantially greater than the howitzer's normal firing distribution. The errors due only to meteorological and projectile parameter measurement were found to account for the largest portion of the cumulative error.

Unclassified

Security Classification

DOCUMENT CONTROL DATA - R&D		
<i>(Security classification of title, body of abstract and indexing annotation must be entered when the overall report is classified)</i>		
1. ORIGINATING ACTIVITY (Corporate author) United Aircraft Corporation Sikorsky Aircraft Division		2a. REPORT SECURITY CLASSIFICATION Confidential
		2b. GROUP 3
3. REPORT TITLE Technical Feasibility Study and Preliminary Design Study Airmobile Artillery (U)		
4. DESCRIPTIVE NOTES (Type of report and inclusive dates)		
5. AUTHOR(S) (Last name, first name, initial) Stuckal, Ernest (NMI)		
6. REPORT DATE March 1966	7a. TOTAL NO. OF PAGES 399	7b. NO. OF REFS 63
8a. CONTRACT OR GRANT NO. DA 44-177-AMC-132 (T)	9a. ORIGINATOR'S REPORT NUMBER(S) USAAVLABS Technical Report 66-7	
b. PROJECT NO.	9b. OTHER REPORT NO(S) (Any other numbers that may be assigned this report) SER 50399	
c. Task 1X120301D03511		
d.		
10. AVAILABILITY/LIMITATION NOTICES In addition to security requirements which apply to this document and must be met, each transmittal outside the agencies of the US Government must have prior approval of US Army Aviation Materiel Laboratories, Fort Eustis, Virginia 23604		
11. SUPPLEMENTARY NOTES	12. SPONSORING MILITARY ACTIVITY U. S. Army Aviation Materiel Laboratories Fort Eustis, Virginia 23604	
13. ABSTRACT The technical feasibility of an airmobile artillery weapon system has been established for dual-weapon and single-weapon systems in a study conducted at Sikorsky Aircraft. Four outstanding conclusions have been drawn: <ol style="list-style-type: none">1. A fully developed, special-purpose airmobile artillery weapon system permits development of a radically new artillery concept: deployment, fire power delivery, and rapid, even immediate, withdrawals in heretofore inaccessible areas.2. The concept shows significant promise even with a system made up of existing aircraft and armament.3. If a single-weapon capability is used, a CH-3B equipped with 4.5 inch spin stabilized (S.S.) rockets will deploy, deliver fire power, and be capable of immediate withdrawal in one-fourth of the time required for the dual-weapon system studied.4. For the mission specified, a single-rotor helicopter can be designed to carry a 105-mm. gun-boosted rocket that will show the same time advantage just mentioned, but with an estimated 65-percent increase in weapon range and 500-percent increase in accuracy over the 4.5-inch spin stabilized rocket system.		

DD FORM 1473
1 JAN 64

Unclassified

Security Classification

14. KEY WORDS	LINK A		LINK B		LINK C	
	ROLE	WT	ROLE	WT	ROLE	WT

INSTRUCTIONS

1. **ORIGINATING ACTIVITY:** Enter the name and address of the contractor, subcontractor, grantee, Department of Defense activity or other organization (*corporate author*) issuing the report.

2a. **REPORT SECURITY CLASSIFICATION:** Enter the overall security classification of the report. Indicate whether "Restricted Data" is included. Marking is to be in accordance with appropriate security regulations.

2b. **GROUP:** Automatic downgrading is specified in DoD Directive 5200.10 and Armed Forces Industrial Manual. Enter the group number. Also, when applicable, show that optional markings have been used for Group 3 and Group 4 as authorized.

3. **REPORT TITLE:** Enter the complete report title in all capital letters. Titles in all cases should be unclassified. If a meaningful title cannot be selected without classification, show title classification in all capitals in parenthesis immediately following the title.

4. **DESCRIPTIVE NOTES:** If appropriate, enter the type of report, e.g., interim, progress, summary, annual, or final. Give the inclusive dates when a specific reporting period is covered.

5. **AUTHOR(S):** Enter the name(s) of author(s) as shown on or in the report. Enter last name, first name, middle initial. If military, show rank and branch of service. The name of the principal author is an absolute minimum requirement.

6. **REPORT DATE:** Enter the date of the report as day, month, year; or month, year. If more than one date appears on the report, use date of publication.

7a. **TOTAL NUMBER OF PAGES:** The total page count should follow normal pagination procedures, i.e., enter the number of pages containing information.

7b. **NUMBER OF REFERENCES:** Enter the total number of references cited in the report.

8a. **CONTRACT OR GRANT NUMBER:** If appropriate, enter the applicable number of the contract or grant under which the report was written.

8b, 8c, & 8d. **PROJECT NUMBER:** Enter the appropriate military department identification, such as project number, subproject number, system numbers, task number, etc.

9a. **ORIGINATOR'S REPORT NUMBER(S):** Enter the official report number by which the document will be identified and controlled by the originating activity. This number must be unique to this report.

9b. **OTHER REPORT NUMBER(S):** If the report has been assigned any other report numbers (*either by the originator or by the sponsor*), also enter this number(s).

10. **AVAILABILITY/LIMITATION NOTICES:** Enter any limitations on further dissemination of the report, other than those imposed by security classification, using standard statements such as:

- (1) "Qualified requesters may obtain copies of this report from DDC."
- (2) "Foreign announcement and dissemination of this report by DDC is not authorized."
- (3) "U. S. Government agencies may obtain copies of this report directly from DDC. Other qualified DDC users shall request through _____."
- (4) "U. S. military agencies may obtain copies of this report directly from DDC. Other qualified users shall request through _____."
- (5) "All distribution of this report is controlled. Qualified DDC users shall request through _____."

If the report has been furnished to the Office of Technical Services, Department of Commerce, for sale to the public, indicate this fact and enter the price, if known.

11. **SUPPLEMENTARY NOTES:** Use for additional explanatory notes.

12. **SPONSORING MILITARY ACTIVITY:** Enter the name of the departmental project office or laboratory sponsoring (*paying for*) the research and development. Include address.

13. **ABSTRACT:** Enter an abstract giving a brief and factual summary of the document indicative of the report, even though it may also appear elsewhere in the body of the technical report. If additional space is required, a continuation sheet shall be attached.

It is highly desirable that the abstract of classified reports be unclassified. Each paragraph of the abstract shall end with an indication of the military security classification of the information in the paragraph, represented as (TS), (S), (C), or (U).

There is no limitation on the length of the abstract. However, the suggested length is from 150 to 225 words.

14. **KEY WORDS:** Key words are technically meaningful terms or short phrases that characterize a report and may be used as index entries for cataloging the report. Key words must be selected so that no security classification is required. Identifiers, such as equipment model designation, trade name, military project code name, geographic location, may be used as key words but will be followed by an indication of technical context. The assignment of links, rules, and weights is optional.

THIS REPORT HAS BEEN DELIMITED
AND CLEARED FOR PUBLIC RELEASE
UNDER DOD DIRECTIVE 5200.20 AND
NO RESTRICTIONS ARE IMPOSED UPON
ITS USE AND DISCLOSURE.

DISTRIBUTION STATEMENT A

APPROVED FOR PUBLIC RELEASE;
DISTRIBUTION UNLIMITED.