

UNCLASSIFIED

AD NUMBER

AD376139

CLASSIFICATION CHANGES

TO: UNCLASSIFIED

FROM: CONFIDENTIAL

LIMITATION CHANGES

TO:
Approved for public release; distribution is unlimited.

FROM:
Distribution authorized to U.S. Gov't. agencies and their contractors; Critical Technology; JUN 1966. Other requests shall be referred to Air Force Rocket Propulsion Lab., Research and Technology Div., Attn: RPPR-STINFO, Edwards AFB, CA 93523. This document contains export-controlled technical data.

AUTHORITY

AFRPL ltr dtd 7 May 1973 AFRPL ltr dtd 7 May 1973

THIS PAGE IS UNCLASSIFIED

GENERAL DECLASSIFICATION SCHEDULE

**IN ACCORDANCE WITH
DOB 5200.1-R & EXECUTIVE ORDER 11652**

THIS DOCUMENT IS:

**Subject to General Declassification Schedule of
Executive Order 11652-Automatically Downgraded at
2 Years Intervals-DECLASSIFIED ON DECEMBER 31, 1972**

BY

**Defense Documentation Center
Defense Supply Agency
Cameron Station
Alexandria, Virginia 22314**

SECURITY

MARKING

The classified or limited status of this report applies to each page, unless otherwise marked.

Separate page printouts MUST be marked accordingly.

THIS DOCUMENT CONTAINS INFORMATION AFFECTING THE NATIONAL DEFENSE OF THE UNITED STATES WITHIN THE MEANING OF THE ESPIONAGE LAWS, TITLE 18, U.S.C., SECTIONS 793 AND 794. THE TRANSMISSION OR THE REVELATION OF ITS CONTENTS IN ANY MANNER TO AN UNAUTHORIZED PERSON IS PROHIBITED BY LAW.

NOTICE: When government or other drawings, specifications or other data are used for any purpose other than in connection with a definitely related government procurement operation, the U. S. Government thereby incurs no responsibility, nor any obligation whatsoever; and the fact that the Government may have formulated, furnished, or in any way supplied the said drawings, specifications, or other data is not to be regarded by implication or otherwise as in any manner licensing the holder or any other person or corporation, or conveying any rights or permission to manufacture, use or sell any patented invention that may in any way be related thereto.

CONFIDENTIAL

376139

AFRPL-TR-66-116

(UNCLASSIFIED TITLE)

EVALUATION OF COLUMBIUM CARBIDE NOZZLES
FOR SOLID PROPELLANT ROCKET MOTORS

E. L. Olcott
Atlantic Research Corporation

In addition to security requirements which must be met, this document is subject to special export controls and each transmittal to foreign governments or foreign nationals may be made only with prior approval of AFRPL (RPPR/STINFO), Edwards, California 93523.

DOWNGRADED AT 3 YEAR INTERVALS
DECLASSIFIED AFTER 12 YEARS
DOD DIR 5200.10

CONFIDENTIAL

COPY NO. 145

ESPIONAGE CLAUSE

This document contains information affecting the national defense of the United States within the meaning of the Espionage Acts, Title 18, U.S.C., Sections 793 and 794. The transmission or the revelation of its contents in any manner to an unauthorized person is prohibited by law.

CONFIDENTIAL

AFRPL-TR-66-116

(UNCLASSIFIED TITLE)

EVALUATION OF COLUMBIUM CARBIDE NOZZLES
FOR SOLID PROPELLANT ROCKET MOTORS

E. L. Olcott
Atlantic Research Corporation

In addition to security requirements which must be met, this document is subject to special export controls and each transmittal to foreign governments or foreign nationals may be made only with prior approval of AFRPL (RFPR/STINFO), Edwards, California 93523.

CONFIDENTIAL

CONFIDENTIAL

FOREWORD

This report was prepared by Atlantic Research Corporation to document work performed under Air Force Contract AF 04(611)-8009. The contract called for the design and fabrication of two replicate columbium carbide nozzles by Atlantic Research Corporation. The nozzles were to be tested at the Air Force Rocket Propulsion Laboratory, Edwards, California. The nozzle design and fabrication took place between 6 February 1962 and 16 September 1962. Due to unforeseen difficulties in the development of the liquid simulator test device at the Rocket Propulsion Laboratory, testing of the second nozzle was not completed until February 25, 1965.

This program was administrated under the direction of the Air Force Rocket Propulsion Laboratory, Edwards, California, with Capt. D. England, Lt. R. Maxwell and Lt. E. Schneider serving as Air Force Project Officers. Mr. Eugene L. Olcott, Director of Materials Division, Atlantic Research Corporation, was responsible for the administrative and technical aspects of the program. Mr. Stanley Miller performed most of the work.

This technical report has been reviewed and is approved.

Earl M. Schneider
Lieutenant, USAF

CONFIDENTIAL

CONFIDENTIAL

TABLE OF CONTENTS

1.0	INTRODUCTION	1
2.0	NOZZLE DESIGN	2
	A. SERVICE CONDITIONS	2
	B. DESIGN	4
	C. ENTRANCE MODIFICATION.	4
	D. FABRICATION.	7
3.0	NOZZLE TEST RESULTS11
	A. NOZZLE INSERT PERFORMANCE.11
	1. Carbide Erosion Mechanism23
	B. OTHER NOZZLE COMPONENTS.23
4.0	CONCLUSIONS AND RECOMMENDATIONS28
	REFERENCES.29
	APPENDIX I.31
	APPENDIX II41

CONFIDENTIAL

CONFIDENTIAL

ILLUSTRATIONS

<u>Figure</u>	<u>Title</u>	<u>Page</u>
1	Columbium Carbide Nozzle Insert.	5
2	Columbium Carbide Nozzle Assembly.	6
3	Entrance Modification of Nozzle #1	8
4	Entrance Modification of Nozzle #2, Drawing RB64D855	9
5	Completed Nozzle for Attachment to Liquid Simulator	10
6	Pressure-Time Curve for Firing of 1st Nozzle . . .	13
7	Post-Firing View of Nozzle No. 1	14
8	Columbium Carbide Nozzle Insert After Firing No. 1	15
9	Pressure-Time Curve for Firing of Second Nozzle. .	16
10	Second Nozzle Before Test	17
11	Post-Firing View of Second Nozzle.	18
12	Columbium Carbide Insert After Test of Second Nozzle	19
13	Photomicrograph (X60) of Etched Cross-Section of Nozzle No. 2	21
14	Photomicrograph (X60) of Etched Cross-Section of Nozzle No. 2 at Area Where Carbide Layer was Eroded	22
15	Entrance Section of Nozzle No. 2 After Firing. . .	24
16	Temperature Time Traces for Firing No. E1	26
17	Recording of Strain Gauges, Firing No. E1	27

CONFIDENTIAL

CONFIDENTIAL

LIST OF TABLES

<u>Number</u>	<u>Title</u>	<u>Page</u>
1	Characteristics of Test Propellant, LPC 556.	3
2	Firing Data for Columbian Carbide Nozzles.	12

CONFIDENTIAL

CONFIDENTIAL

1.0 INTRODUCTION

Refractory carbides possess the highest melting points of known refractory materials and, therefore, offer considerable promise for application under severe high-temperature duty cycles. The usefulness of the refractory carbides for rocket nozzle inserts has been limited by their relatively low thermal shock resistance. During the initial portion of the rocket nozzle firing cycle, a severe thermal gradient exists between the gas side and the back side of the nozzle insert, and as a result high tensile stresses are imparted to the backside. The relatively low fracture resistance of the refractory carbides often permits complete shattering of the carbide material from the thermal stresses. Researchers have labored to overcome the shortcomings of refractory carbides through such techniques as pre-stressing, grain size control, reinforcement, and dispersion of a low modulus phase. The Carborundum Company has had notable success in the use of a dispersed phase of graphite in a refractory carbide matrix to improve the fracture resistance of these materials. It was also found in subscale rocket nozzle tests that a thin layer of pure carbide could be used in connection with the carbide-dispersed graphite backup for acceptable fracture resistance. A discussion of the development of these materials may be found in Reference 1 and a discussion of the behavior of subscale nozzles made of such materials has been given in Reference 2. Recently, another approach to this problem was accomplished by the addition of sufficient carbon to a molten carbide to permit the precipitation of graphite flakes in the matrix during solidification. In this case, the low modulus dispersion is more in the form of graphite flakes.

Previous subscale tests on refractory carbides containing a pure carbide surface with a carbide-graphite backup had shown acceptable erosion and fracture behavior (Reference 2). The objective of this program was to scale up the test conditions to a 5,000-lb. thrust motor to determine the usefulness of refractory carbide nozzle inserts. The contract provided for the design and fabrication of two replicate nozzles to fit the Edwards test device which at the time of the contract initiation was a liquid simulator. Columbium carbide was selected as the carbide to be used in the nozzles because previous experience had shown this carbide to be sufficiently erosion resistant in the environment contemplated, and this carbide possessed a density less than that of many of the other carbides and would be advantageous for flight weight applications.

CONFIDENTIAL

2.0 NOZZLE DESIGN

A. SERVICE CONDITIONS

The service conditions under which the nozzles were to be tested were initially specified as follows:

1. Thrust - 5000 lbs.
2. Burn time - 60 seconds (minimum)
3. Flame Temperature - 5500°F to 6000°F
4. Chamber Pressure - 500 psi
5. Nozzle contoured to provide for expansion to atmospheric exhaust pressure of 13.1 psi (Edwards AFB Rocket Site).
6. The propellant was later defined in more detail as follows:

$$I_{sp} = 264.56 \text{ sec} \frac{(1000)}{14.7}$$

$$\text{Density} = 0.0635 \text{ lb/in}^3$$

$$T_{\text{Flame Chamber}} = 3185^\circ\text{K} (5275^\circ\text{F})$$

Propellant Composition:

$$\text{Al} = 20\%$$

$$\text{CH}_2 = 15\%$$

$$\text{NH}_4\text{ClO}_4 = \underline{65\%}$$

$$100\%$$

The oxidation ratio calculated from the combustion products of the above propellant was 1.01, which was sufficiently low to indicate an anticipated erosion rate of from .1 to .2 mil/sec for columbium carbide based on previous subscale tests.

The test nozzles were designed, fabricated and delivered prior to the change in test conditions which was occasioned by difficulties of the Rocket Propulsion Laboratory with the liquid test simulator. It was subsequently decided by the Rocket Propulsion Laboratory Personnel that the two nozzles would be tested in the Char Motor with the test propellant LPC-556 polycarbutene which has a calculated flame temperature of 5640°F (1000 psi motor pressure) and a calculated oxidation ratio of 1.26. The combustion products of this propellant are shown in Table 1. The maximum pressures obtained with the nozzle diameters selected on the basis of the liquid simulator turned out to be approximately 700 psi. It may be noted that the solid propellant Char Motor test conditions were more severe with regard to pressure, oxidation ratio and propellant temperature than

CONFIDENTIAL

TABLE 1

CHARACTERISTICS OF TEST PROPELLANT, LPC 556

Composition: 68% ammonium perchlorate
17% aluminum
Balance, polycarbutene binder

T°F 5643 (Chamber 1000 psi)

I_{sp} theo, shifting, lbf-sec/lbm 263

I_{sp}^{15} standard 245, estimated

Composition of Principal Exhaust Products

<u>Constituent</u>	<u>Chamber</u>	<u>Shifting Exhaust</u>
CO ₂	0.0498	0.0654
H ₂	1.1629	1.2371
AlCl ₂	0.0355	0.0003
OH	0.0218	0.0002
AlCl	0.0162	0.0000
H ₂ S	0.0011	0.0029
H ₂ O	0.4967	0.4273
H	0.1129	0.0051
HCl	0.4588	0.5762
Al ₂ O ₃ (liq)	0.2884	0.0000
Cl	0.0303	0.0018
CO	0.9144	0.8995
N ₂	0.2975	0.2982

CONFIDENTIAL

the propellant initially selected for use in the liquid simulator. Fortunately, however, the more severe test conditions gave information more applicable to current propellant systems than the initial test propellant selection.

B. DESIGN

The columbium carbide insert design is shown in Figure 1. It features a reasonably symmetrical cross-section to minimize stress effects related to changes in section. The configuration provided a port/throat ratio of 1.18 at both entrance and exit ends. Retention is both by bearing at the exit end and by shear with a 7 degree ramp angle. Redundant retention was provided to permit retention of separate segments in the event that complete fracture occurred during the test firing. The insert was fabricated to provide maximum carbide density on the gas side and sufficient dispersion of graphite particles through the backup surface to provide the degree of fracture resistance believed to be necessary.

This insert was incorporated in the layout design shown in Figure 2. A preliminary version of this nozzle was thermally analyzed (Appendix I) and stress analyzed (Appendix II). The heat transfer calculations indicated the desirability of incorporating the graphite heat sink (Part 5 of Figure 2) to reduce the temperature of the hot side of the cast zirconia insulation member (Part 4 of Figure 2). This precaution was necessary only if the upper limit of propellant temperature required in the contract (6000°F) was used in the test program.

The castable zirconia insulation materials used for Parts 4 and 9 of Figure 2 were developed at Atlantic Research for use as a castable insulating material to provide a refractory backup for the hotter gas side materials. The development of this material is discussed in Reference 2. This material has the capability of being cast around brittle materials to offer firm backup support without precision machined fit-up. At temperatures above 4000°F this material softens and must be used with caution. The graphite segments used on each side of the throat insert can be considered a routine application for such materials. The phenolic-asbestos entrance material was designed to project into the liquid simulator thrust chamber over the water-cooled flange attachment which was part of the simulator. The flange of the nozzle assembly was expected to, in turn, be cooled in part by the water-cooled flange to which it was attached. The phenolic-asbestos exit section was selected to be compatible with the propellant initially selected.

C. ENTRANCE MODIFICATION

After it became evident that the liquid simulator would not be available to test the nozzles, the Rocket Propulsion Laboratory

CONFIDENTIAL

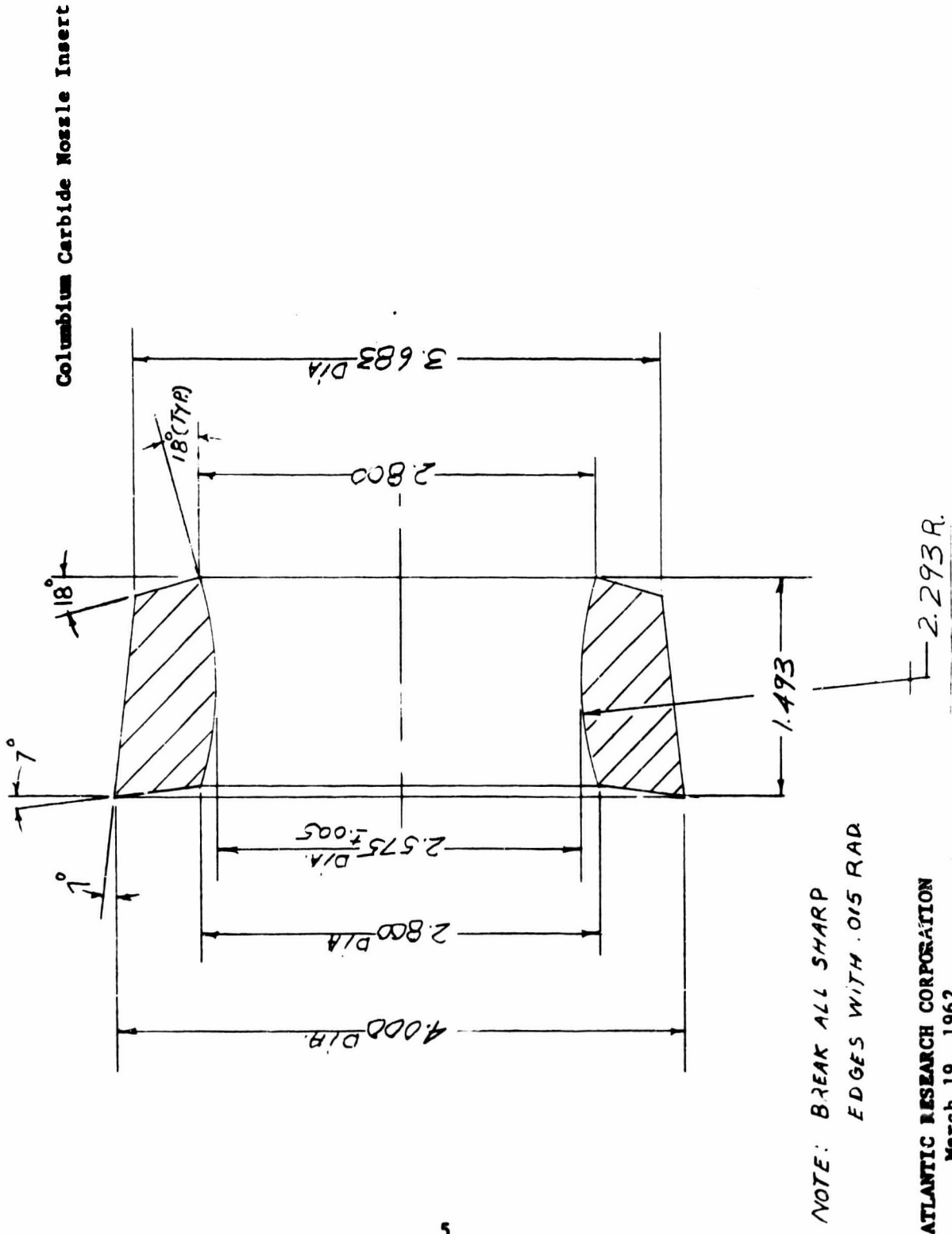
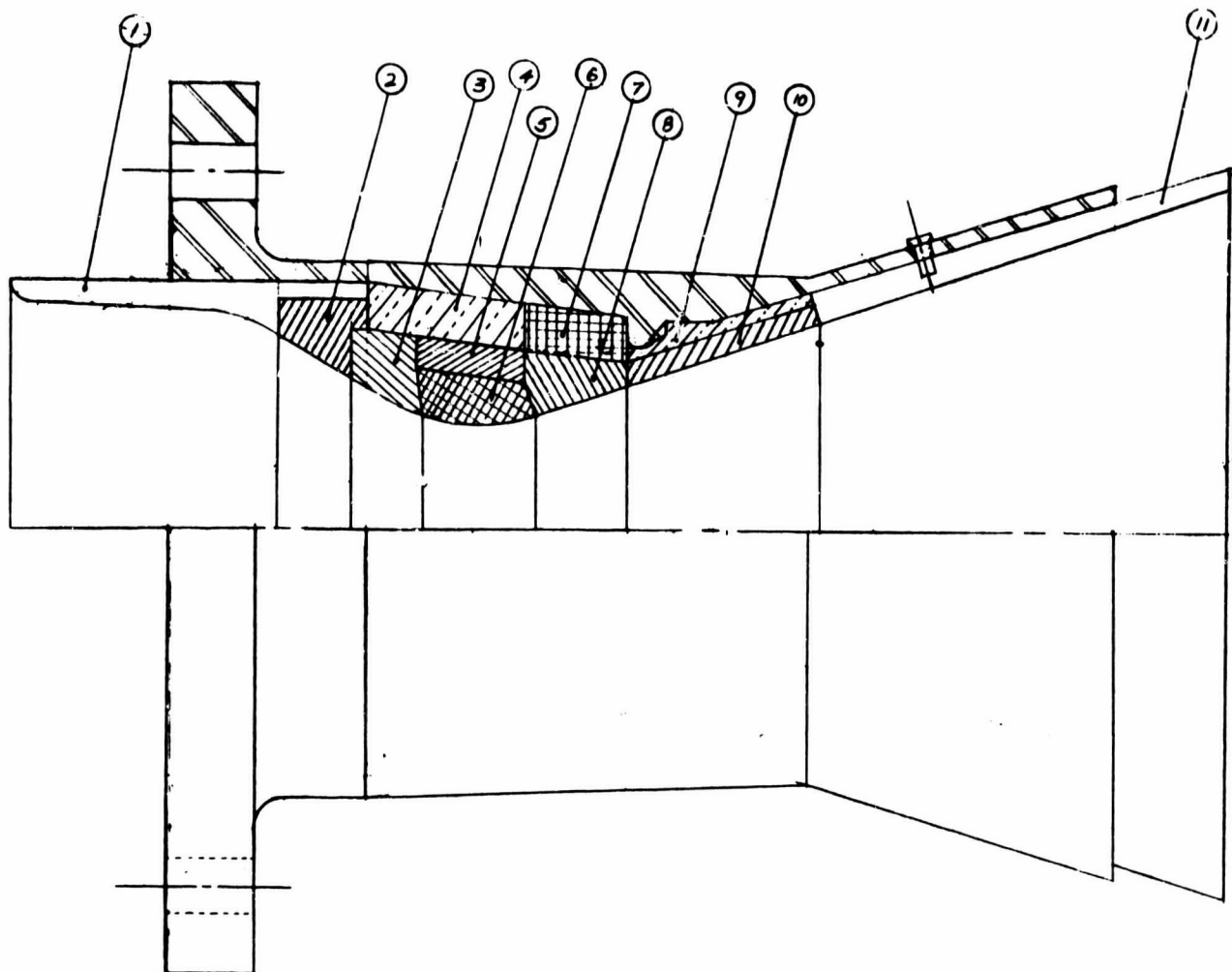

Figure 1. Columbium Carbide Nozzle Insert.

ATLANTIC RESEARCH CORPORATION
March 19, 1962

CONFIDENTIAL

CONFIDENTIAL



NO.	PART	MATERIAL
1	APPROACH INSULATION	PHENOLIC-ASBESTOS
2	APPROACH SEGMENT	ATJ OR ANDG GRAPHITE
3	APPROACH SEGMENT	ATJ OR ANDG GRAPHITE
4	INSERT BACK-UP INSULATION	CASTABLE ZrO ₂ CERAMIC
5	INSERT HEAT SINK	ATJ GRAPHITE
6	INSERT	CBC + GRAPHITE DISPERSION
7	INSERT BACK-UP INSULATION + PETAINER	MACHINED GA CARBON
8	EXPANSION CONE SEGMENT	ATJ GRAPHITE
9	EXPANSION INSULATION	CASTABLE ZrO ₂ CERAMIC
10	EXPANSION CONE SEGMENT	ATJ OR ATL GRAPHITE
11	EXPANSION CONE	PHENOLIC-ASBESTOS

Figure 2. Columbian Carbide Nozzle Assembly.

CONFIDENTIAL

CONFIDENTIAL

Personnel designed and fabricated a transition flange to fit the closure of the solid propellant motor. This flange is shown in Figure 3 along with the mating portion of the columbium carbide nozzle. It was recognized at the time that the use of the silica filled Buna N facing the nozzle flange substituted for the water-cooled metal flange called for in the initial design arrangement was somewhat questionable for dependable performance, but was employed as an expedient. The transition adaptor for the second nozzle was also designed and fabricated by Rocket Propulsion Laboratory Personnel and is shown in Figure 4 (Drawing RB64D855). This design featured a more erosion resistant approach section which mated with the graphite entrance portion of the test nozzle.

D. FABRICATION

The two test nozzles were fabricated concurrently in the shops of Atlantic Research Corporation. The columbium carbide inserts were made by the Carborundum Company, Niagara Falls, New York. A dense columbium carbide layer 1/8 inch in thickness was backed up by a mixture of 30 volume per cent columbium carbide-70 volume per cent graphite dispersion. This carbide-graphite ratio was found to be fracture resistant from previous subscale tests. The inserts were fabricated by hot pressing at 2450°C and 6000 psi. Nozzle fabrication was completed on 16 September 1962.

The instrumentation on the nozzles consisted of two biaxial strain gauges located on the nozzle shell structure and four thermocouples located at various depths in the nozzle, one of which went through to the cold side of the carbide insert. During the re-work of the nozzle entrance section of the second nozzle at the Rocket Propulsion Laboratory all of the instrumentation was removed prior to firing. Figure 5 shows a completed nozzle prior to shipment.

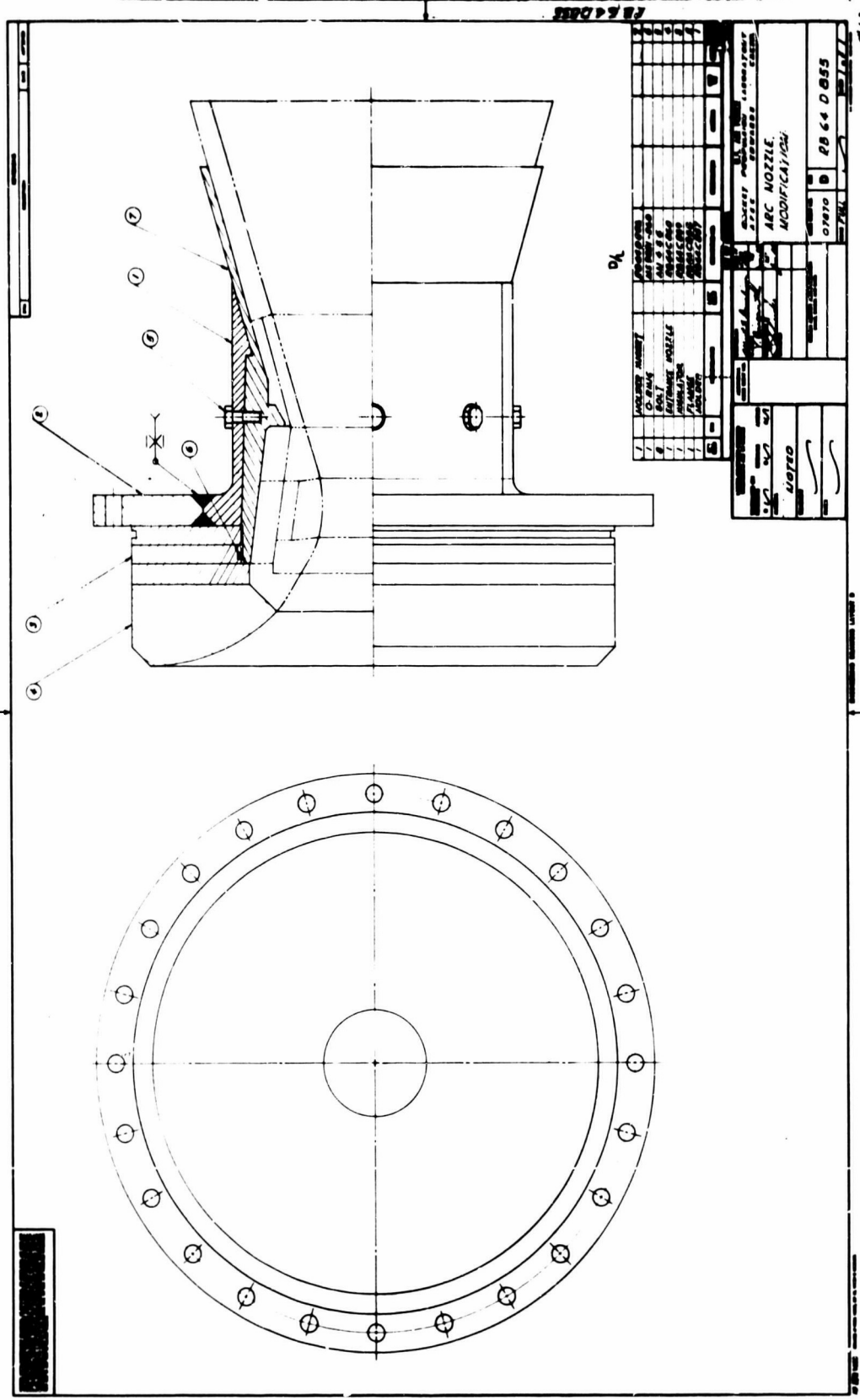
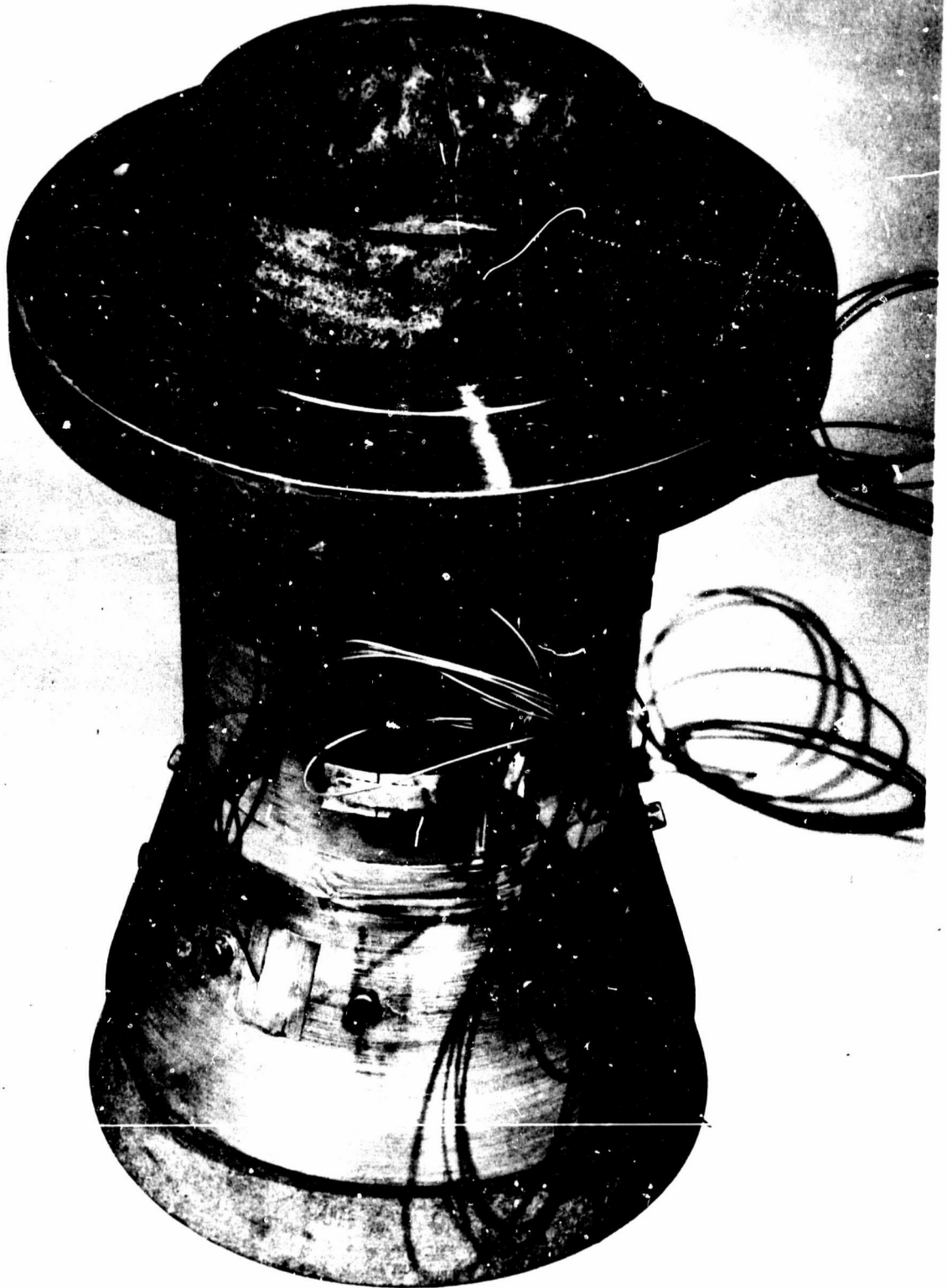

Figure 4. Entrance Modification of Nozzle No. 2, Drawing RB64D855.

CONFIDENTIAL



11332

Figure 5. Completed Nozzle for Attachment to Liquid Simulator.

CONFIDENTIAL

3.0 NOZZLE TEST RESULTS

The first firing, Nozzle E-1, was conducted on 18 March 1964, and the second firing, E-2, was conducted on 25 February 1965, at the Rocket Propulsion Laboratory. The mass flow of the Char Motor was 21 pounds per second. Firing data on the nozzles are shown in Table 2.

Firing E-1 was normal until 41 seconds at which time the movie film showed a gas leak occurred at the junction of the transition section at the base of the nozzle. The pressure-time curve of this firing is shown in Figure 6. It is believed that the silica filled Buna N insulation section and the rather thin phenolic-asbestos section which was designed to cover a water-cooled, stainless flange eroded in such a manner as to permit heating the steel at the flange section. A radial crack in the graphite entrance section opened to permit gas flow in this area. The gas leak rapidly increased and impinged upon the outside of the expansion cone and burned a hole in it as can be seen in Figure 7. The test insert removed from the nozzle assembly after firing is shown in Figure 8. The carbide insert suffered no discernable ill effects from the nozzle burn-through. The globule of aluminum oxide that can be observed in the entrance section was related to the low pressure burning after burn-through.

Firing E-2 progressed satisfactorily insofar as the insert was concerned for the full duration, 63 seconds. The pressure-time curve is shown in Figure 9. Figure 10 shows the second nozzle mounted on the Char Motor prior to test. Film coverage shows that at 38 seconds the aft end of the expansion cone started to deteriorate and was lost at 47 seconds. Figure 11 shows the nozzle after test. Figure 12 shows the removed insert after test.

A. NOZZLE INSERT PERFORMANCE

The erosion rate for the first nozzle was calculated as 2.2 mil/sec by dividing the total radial change by the time to nozzle burn-through. Since some of the total erosion probably occurred during the period of low pressure burning, the actual erosion rate for the normal part of the firing cycle should be less than this value. The shape of the pressure-time curve for this firing (Figure 6) indicates that much of the total erosion occurred during the first 12 seconds. This behavior indicates the likelihood that some of the 1/8-inch thick dense carbide surface spalled and was carried away by the gas stream. Both nozzles showed substantial areas where the dense carbide coating was completely gone. The underlying 30-70 carbide-graphite mixture appeared to possess fair erosion resistance and was not unduly eroded. The second nozzle showed an average erosion rate of 1.6 mil/sec for the full duration. These erosion rates can be compared with a measured rate of 2.2 mil/sec determined for ATJ graphite under similar firing conditions in another program (Reference 3).

CONFIDENTIAL

TABLE 2
FIRING DATA FOR COLUMBIUM CARBIDE NOZZLES

Firing	Total Burning Time (T) (Seconds)	Maximum Pressure (psi)	Average Pressure (P) (psi) ^a	Diameter of Throat		Calculated Avg. Erosion Rate (mil/sec)
				Before (in)	After ² (in)	
E-1 (AFFTC 0005)	54 ¹	685	553	2.575	$\frac{2.757}{2.882}$	<2.2
E-2 (AFFTC 0018)	65	694	662-	2.575	$\frac{2.785}{2.810}$	1.6

¹ to burn through

² minimum and maximum dimensions

CONFIDENTIAL

CONFIDENTIAL

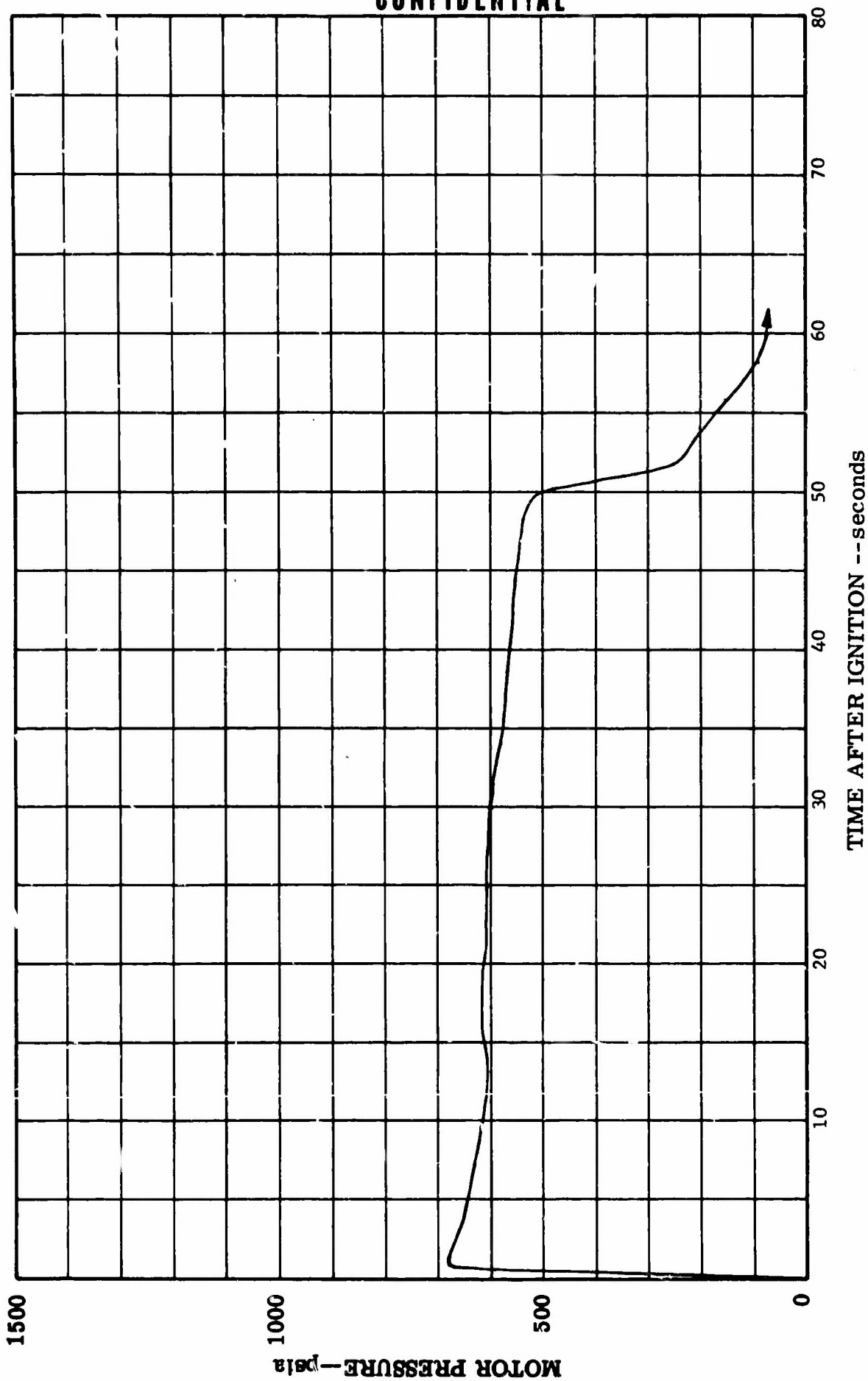

Figure 6. Pressure-Time Curve for Firing of 1st Nozzle.

CONFIDENTIAL

CONFIDENTIAL



11353

Figure 7. Post-Firing View of Nozzle No. 1.

CONFIDENTIAL

CONFIDENTIAL



E-1

11354

Figure 8. Columbiu Carbide Nozzle Insert After Firing No. 1.

CONFIDENTIAL

CONFIDENTIAL

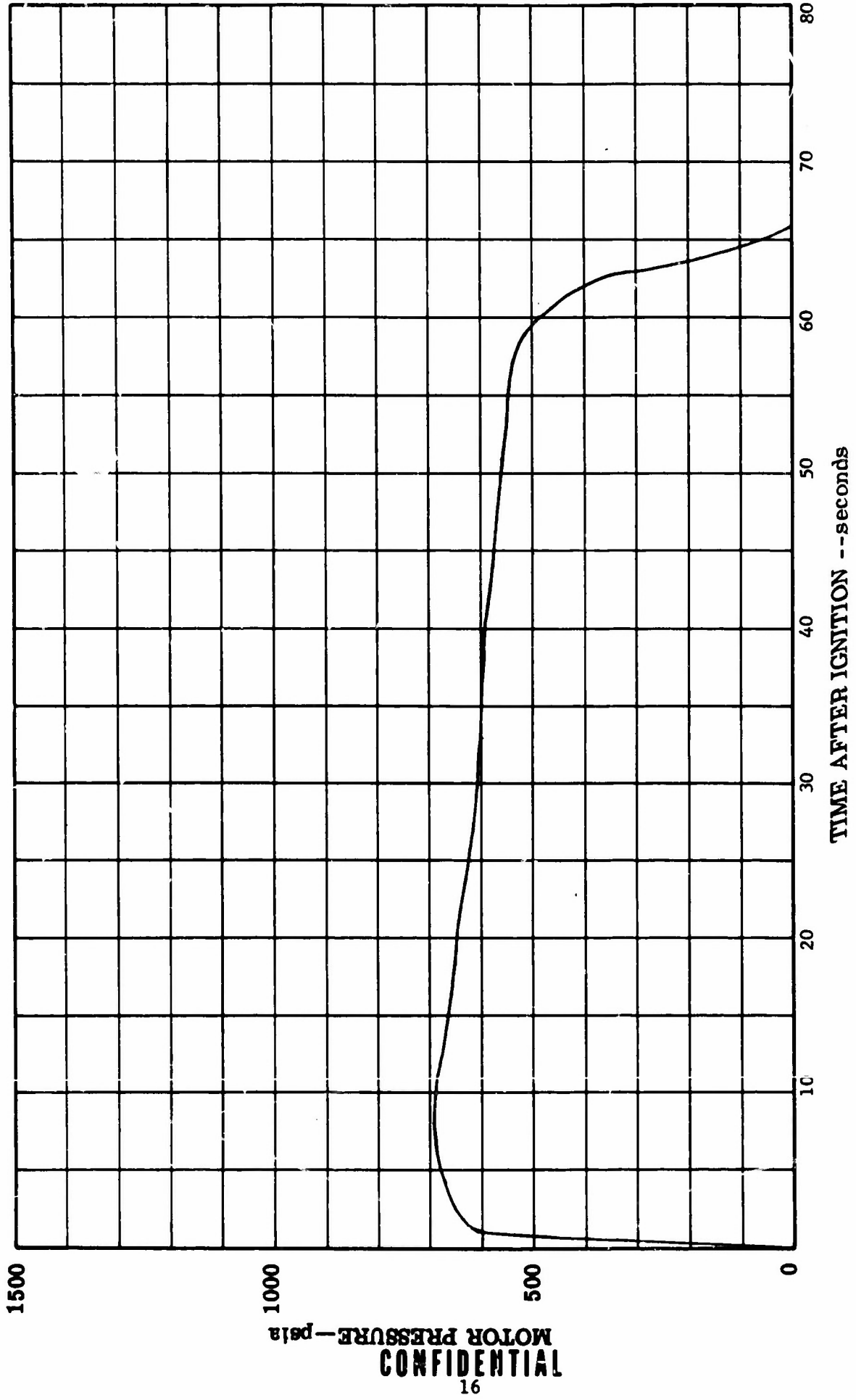
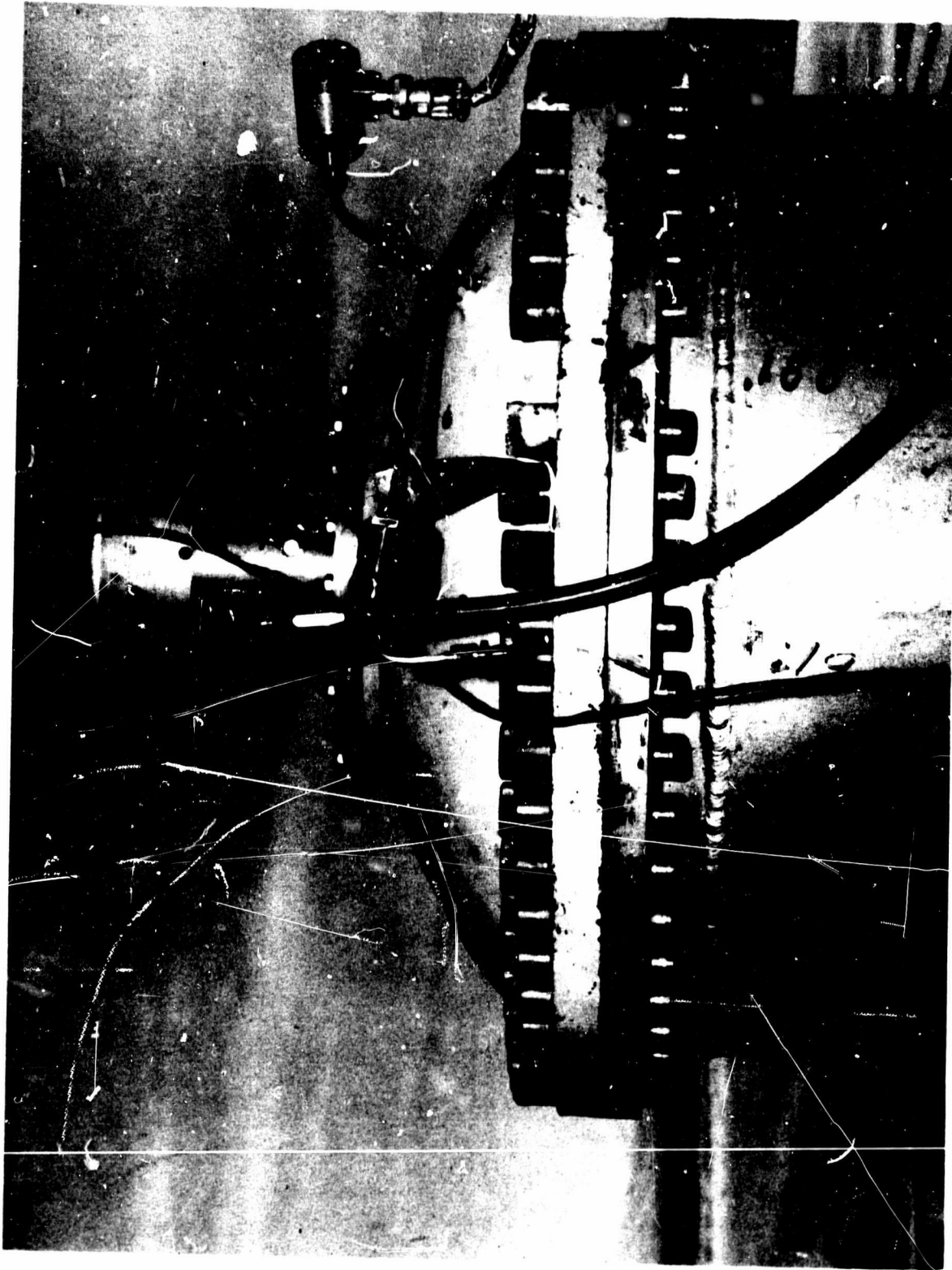

Figure 9. Pressure-Time Curve for Firing of Second Nozzle.

CONFIDENTIAL
16

CONFIDENTIAL



Q11333

Figure 10. Second Nozzle Before Test.

CONFIDENTIAL

CONFIDENTIAL

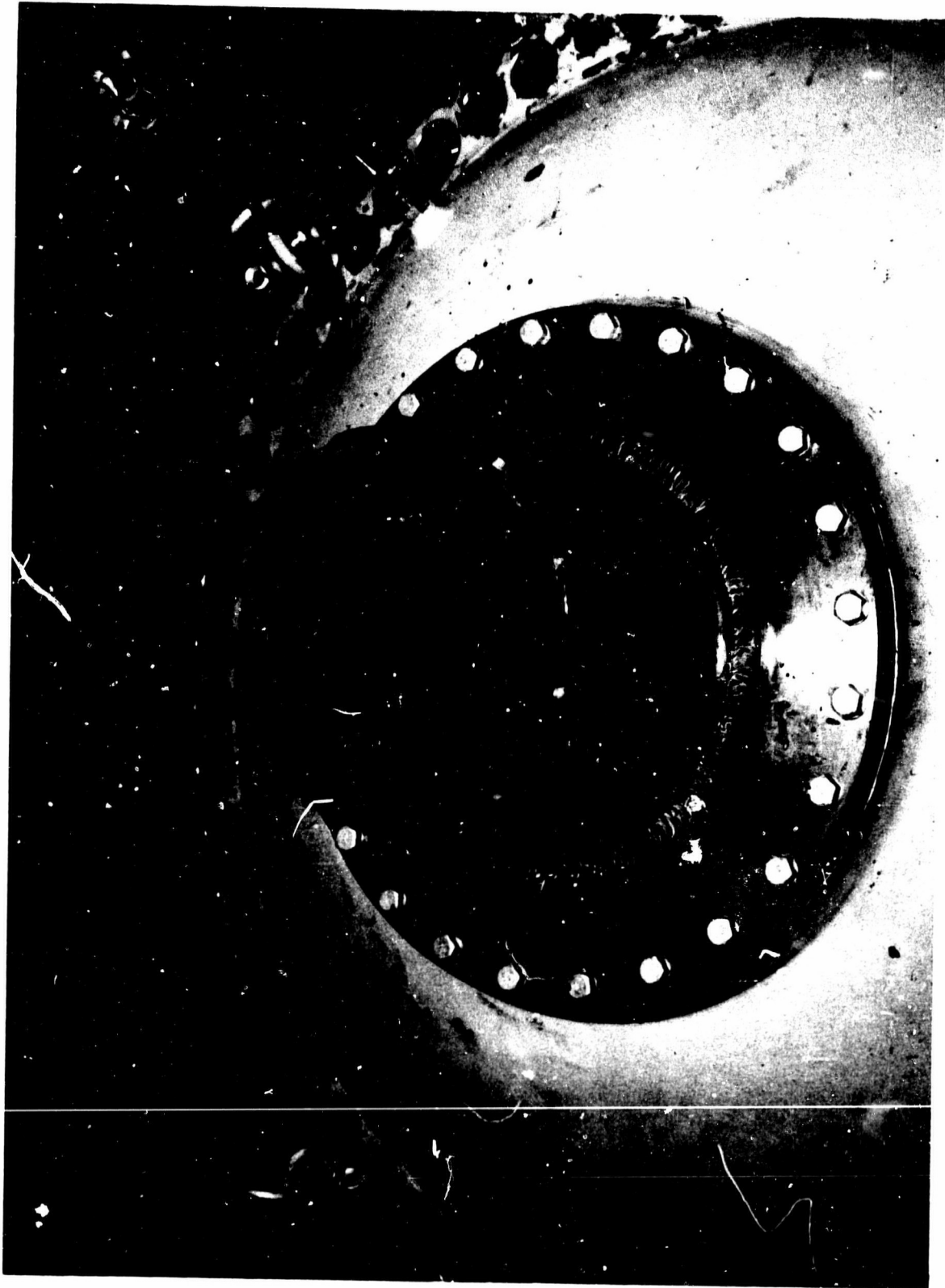

Q11334

Figure 11. Post-Firing View of Second Nozzle.

CONFIDENTIAL

CONFIDENTIAL

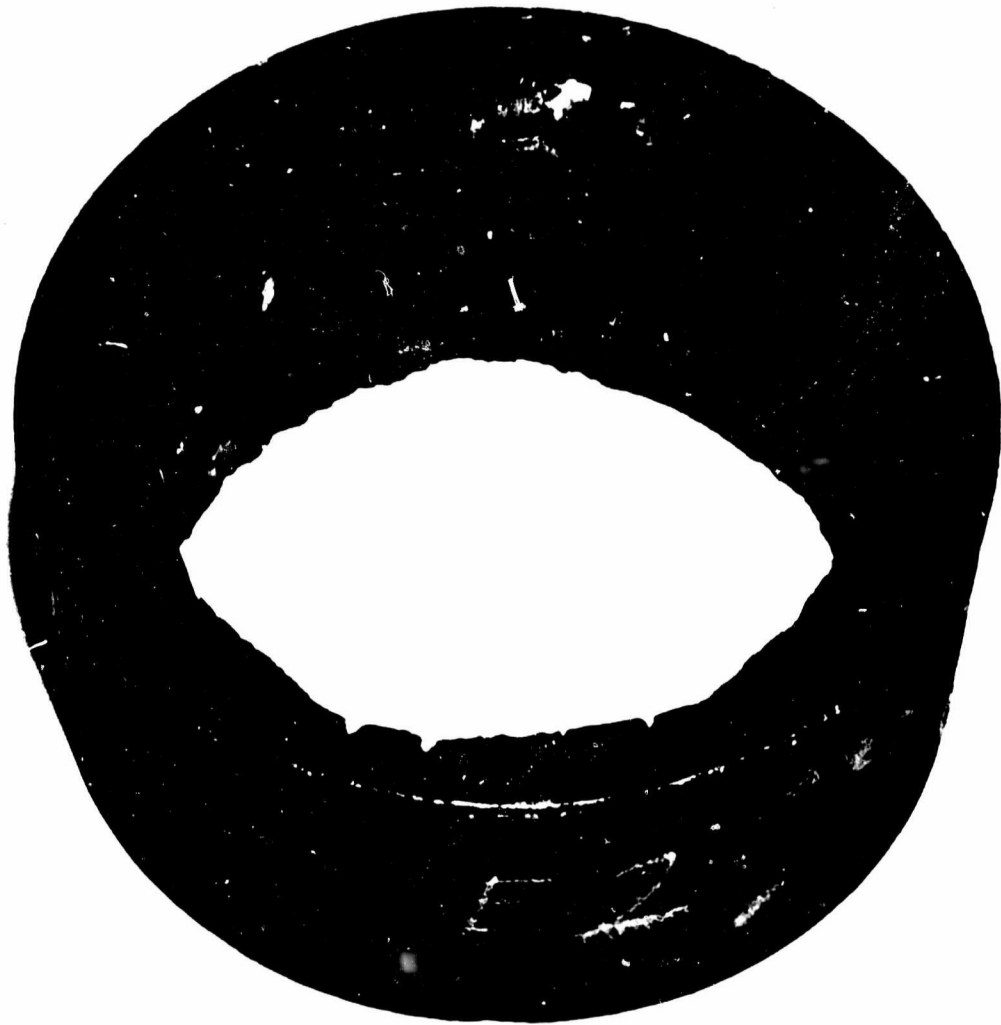

E-2

11335

Figure 12. Columbian Carbide Insert After Test of Second Nozzle.

CONFIDENTIAL

CONFIDENTIAL

A few tight axial cracks were observed on the outside of the second insert. These cracks had the appearance of cool-down cracks. The first nozzle contained no visible outside cracks. The portions of the graphite-free carbide surface which remained on the gas side of the insert contained tight cracks both in the axial and transverse direction generally spaced at 1/2-inch intervals. These cracks appear to have been present during the firing but did not effect the performance or the erosion except as they may have permitted portions of the graphite-free carbide surface to be removed. If the bond strength of the carbide surface the carbide-graphite substrate were uniformly good, the cracks would not have caused any losses of the carbide surface. As can be seen in Figure 8 and 12, the carbide inserts were still in one piece after firing and showed no major structural deficiencies. The performance of such brittle materials under the severe duty cycle can be considered good.

Microscopic examination of the cross-section of the nozzle insert after Firing No. 2 showed no unusual deterioration. The carbide layer remaining was of high density, well bonded and of fine grain size. No significant reaction layer was observed on the gas side. The cracks which were visible on the gas side were tight and did not appear to be sources of accelerated erosion as can be observed in Figure 13. The portions of the gas side surface which contained no dense carbide coating blended to a section of a tapered thickness of dense carbide coating where the carbide remained as can be observed in Figure 14. This appearance indicates that, in the sections examined any loss of the 1/8-inch thick carbide surface was gradual rather than by failure at the carbide to carbide-graphite interface.

The location of the composite substrate on the cross-section examined after firing indicated that the nominal 1/8-inch thick carbide layer had not been attained at the entrance face edge of the insert. In both nozzles no dense carbide surface material remained in this location. There are indications that it may have originally been as little as 10 or 20 mils in thickness at this point. Although the influence of the thin coating at this location cannot be determined, it is likely that some of the erosion at the throat section could be attributed to this manufacturing irregularity.

CONFIDENTIAL

CONFIDENTIAL



11337

**Figure 13. Photomicrograph (X 60) of Etched Cross-Section of
Nozzle No. 2.**

CONFIDENTIAL

CONFIDENTIAL

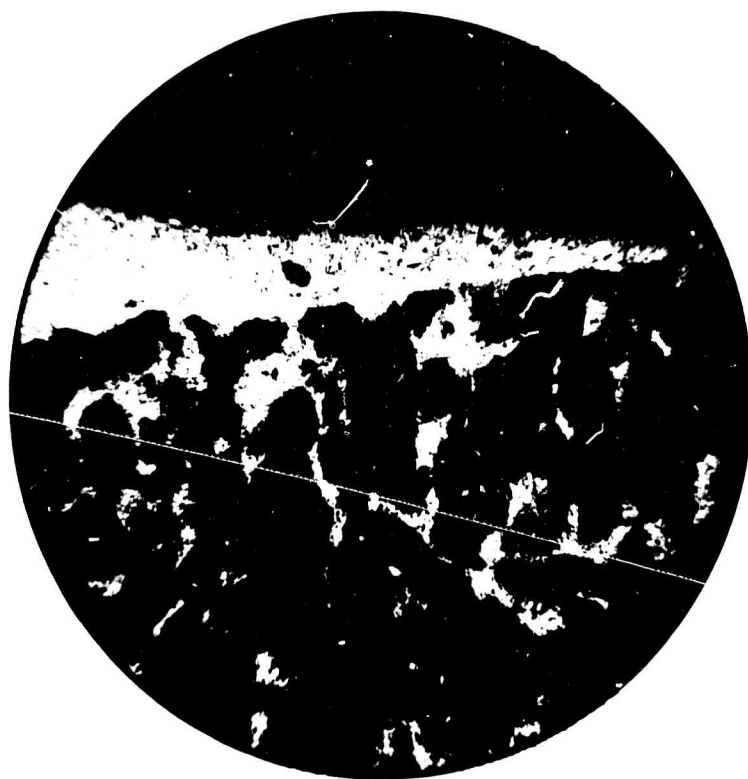

11338

Figure 14. Photomicrograph (X 60) of Etched Cross-Section of Nozzle No. 2 at Area Where Carbide Layer was Eroded.

CONFIDENTIAL

CONFIDENTIAL

1. Carbide Erosion Mechanism

Current and previous studies have shown that the principal erosion mechanism for a refractory carbide at the temperatures involved with the current Char Motor propellant is oxidative chemical attack (Ref. 2 and 4). The common oxidative combustion species, CO_2 , and H_2O , have been found to be very reactive with hot-pressed carbides made by the same procedure utilized for the nozzle inserts. Under laboratory test conditions significant differences have been found in the oxidation effects on various refractory carbides which are caused by differences in the characteristics and protective quality of the metal oxide product produced at the carbide surface. For columbium carbide the protection by the oxide failed to be effective at a temperature well below 4000°F .

Work to date, although not complete, indicates that both hafnium carbide and zirconium carbide are more oxidation resistant (Ref. 4). The protective action of the oxidation product formed on hafnium carbide appears to persist up to temperatures near 5000°F under laboratory conditions. The presence of a metal oxide condensed phase, such as aluminum oxide, in the solid propellant exhaust will undoubtedly reduce the effectiveness of protection by an oxide layer, but it does seem likely that the relative performance of the various carbides may be related to that observed in laboratory tests. Thus, the investigation of other carbide materials for nozzle service might produce improved results.

B. OTHER NOZZLE COMPONENTS

Some of the other nozzle components did not perform so well. The graphite entrance piece which had been applied to the nozzle during the re-work operation at the Rocket Propulsion Laboratory to effect the fit in the solid propellant motor showed a gaping axial crack after each firing. The crack in the second nozzle is shown in Figure 15. The width of the crack and the local erosion which occurred underneath the graphite indicated the open crack was present for much of the firing duration. The opening in the graphite entrance piece permitted gas impingement on the silica-Buna N insulation in the first nozzle, which subsequently resulted in burn-through at this point. In the second nozzle, the gas flowing behind the cracked graphite entrance piece impinged on the silica-phenolic material, the asbestos-phenolic insulation and also on the castable zirconia insulation backup. None of these materials are sufficiently resistant to gas impingement to remain unaffected and so a groove was formed which extended to a point behind the carbide insert itself. This penetration was not sufficient to significantly affect the performance of the nozzle by the end of firing, 63 seconds.

It was also indicated that the phenolic-asbestos expansion cone was of insufficient thickness and support to withstand the full firing duration under the test conditions.

CONFIDENTIAL



11336

Figure 15. Entrance Section of Nozzle No. 2 After Firing.

CONFIDENTIAL

CONFIDENTIAL

Figure 16 shows the temperature traces obtained from the first firing. The three thermocouples were located on the steel housing as shown. It is evident from the temperature increase measured by thermocouple T1 that this thermocouple was located near the region of nozzle burn-through which coincided with the axial crack in the graphite entrance section. Thermocouples T2 and T3 were essentially unheated up to the point at which instrumentation was lost.

Figure 17 shows the recording of strain gauges mounted on the nozzle barrel. Items 2 and 3 are a two strain gauge rosette located near the flange. The calculated principal stresses from these strain gauge readings are:

maximum normal stresses - 15,170 psi tensile
minimum normal stress - 10,550 psi tensile
maximum shear stress - 2,305 psi

Items 4 and 5 also form a two strain gauge rosette which is located on the nozzle barrel at a point opposite the insert retention shoulder. Calculations of principal stresses from these gauges are:

maximum normal stress - 21,600 psi compressive
minimum normal stress - 16,800 psi compressive
maximum shear - 2,305 psi

It should be noted that the strain gauges were not temperature compensated and so the readings used in the above calculations were taken 4 seconds after ignition. After this time the temperature effects influenced the gauge output, and further stress calculations could not be made.

CONFIDENTIAL

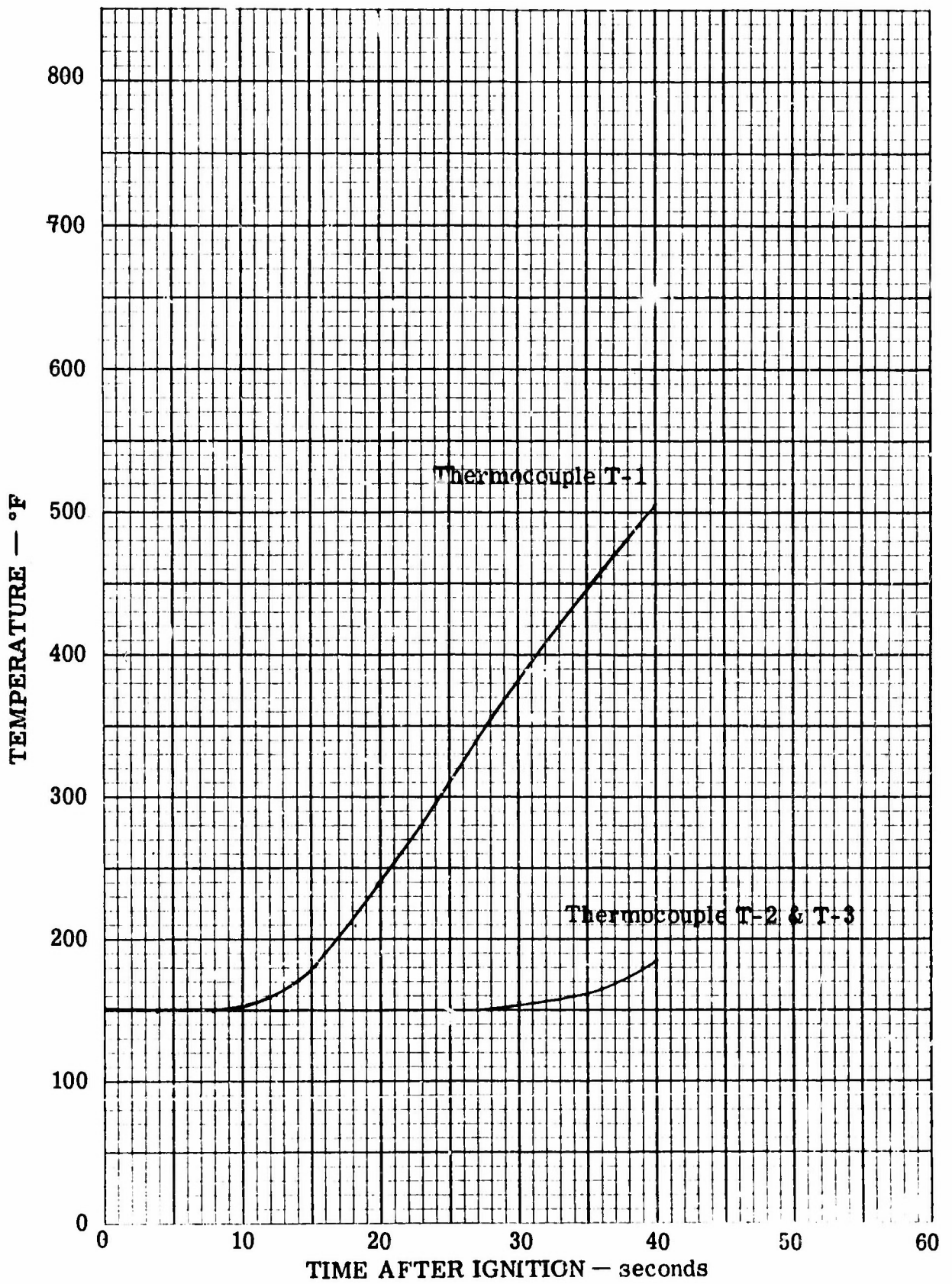

Figure 16. Temperature-Time Traces for Firing No. E-1.

CONFIDENTIAL

CONFIDENTIAL

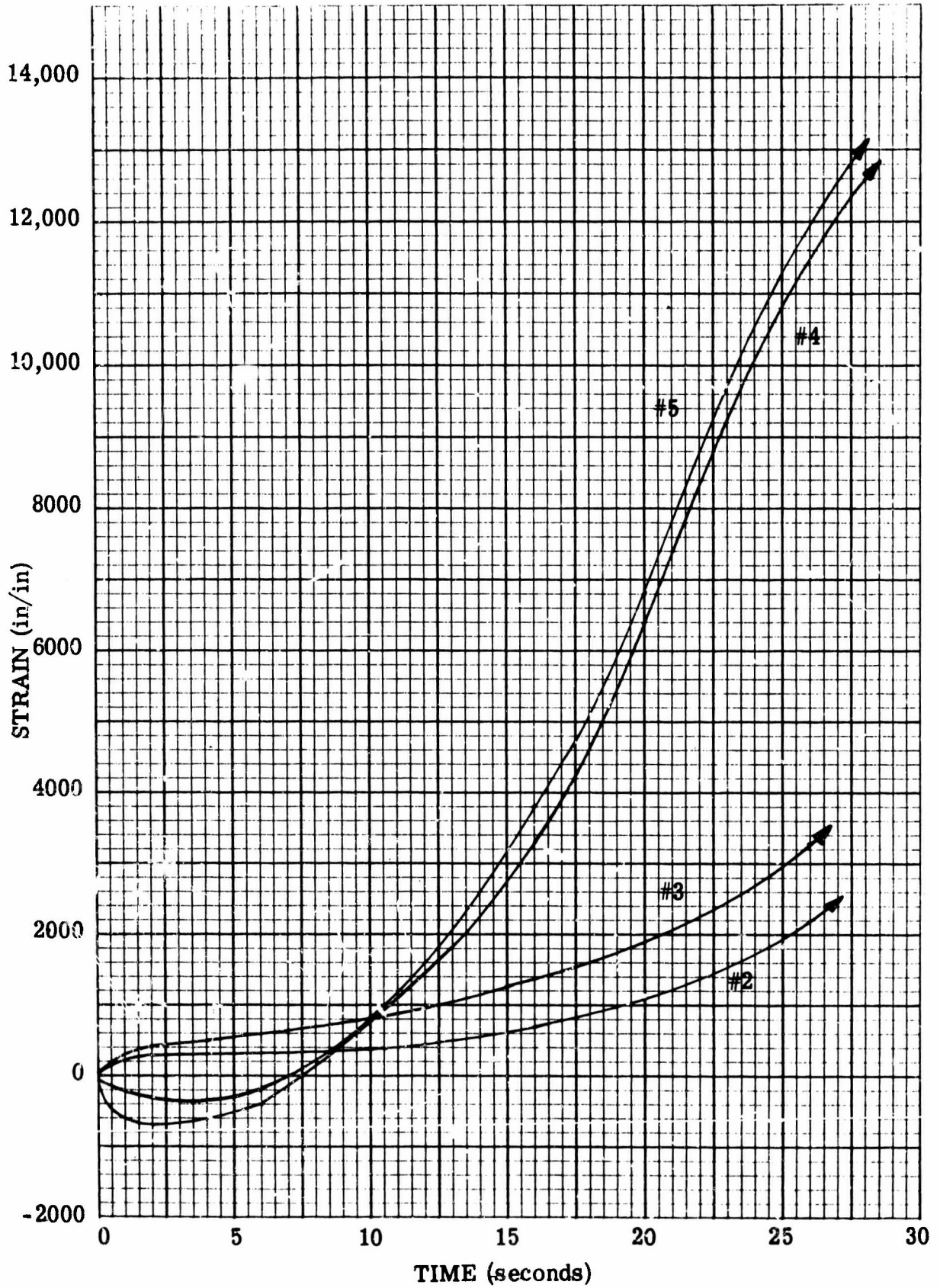

Figure 17. Recording of Strain Gauges, Firing No. E-1.

27

CONFIDENTIAL

CONFIDENTIAL

4.0 CONCLUSIONS AND RECOMMENDATIONS

Columbium carbide nozzle inserts performed satisfactorily in the 5,000-lb. Char Motor with an oxidizing solid propellant. Erosion encountered was believed to be due primarily to oxidation of the carbide. No significant fracture of the brittle insert material occurred. Nozzle inlet damage related to a wide crack in the graphite entrance cap of each nozzle probably increased the nozzle insert heating and contributed to the erosion of the carbide. Advances in the state-of-the-art since the manufacture of the tested carbide inserts should permit modest improvements with similar current materials. In particular a manufacturing discrepancy which left a very thin carbide layer at the entrance face could be avoided.

Other work at Atlantic Research Corporation has indicated that other refractory carbides such as hafnium carbide are more suitable in oxidizing environments than is columbium carbide. Additional feasibility studies of such materials are believed desirable.

Because of the unusually high temperature compatibility of the refractory carbides, they should be considered for selected environments where they may be chemically compatible with a suitable environment.

CONFIDENTIAL

List of References

1. Carborundum Company, Quarterly Progress Report, Refractory Materials Suitable for Use in Guided Missile Propulsion Systems (U), Contract NOrd 18136, CONFIDENTIAL.
2. Special Projects Office Materials Program (U), NOW 62-0511, Final Report. April 1963, CONFIDENTIAL.
3. Atlantic Research Corporation, Castable Carbon for Nozzle Applications, AFRPL TR-64-183, Third Quarterly Progress Report, Contract AF 04(611)-9718, December 1964.
4. Batchelor, J. D., Atlantic Research Corporation, Behavior of Nozzle Materials Under Extreme Rocket Motor Environments, Quarterly Progress Report, Contract NOW-0393-c, April 1965.

CONFIDENTIAL

APPENDIX I

HEAT TRANSFER ANALYSIS OF COLUMBIUM CARBIDE

The heat transfer analysis of the columbium carbide nozzle is outlined in this Appendix. The enclosed plots show the transient temperature time history of the nozzle during the motor firing. It was assumed that the combustion temperature of the propellant gases was 6000°F. On this basis, the expected surface temperature of the nozzle throat hot side surface at 60 seconds will be about 5400°F. The cold side temperature will be about 4200°F. The surface temperature of the approach section at the end of 60 seconds of firing will be about 5200°F. The surface temperature of the exit portion of the nozzle insert was estimated to be about 150°F less than that of the approach section.

At the time the thermal analysis of the nozzle design was conducted, temperature dependent properties of the composite columbium carbide material were not available. For this reason, simplified analytical techniques believed to be adequate for the purpose intended were applied. Ordinarily, a two dimensional transient heat transfer program for the 7090 computer is used for problems of this type.

Because of the rework of the nozzles for use on the test motor selected, the temperature instrumentation was removed and correlation of measured temperatures with calculated temperatures could not be obtained.

CONFIDENTIAL

HEAT TRANSFER CALCULATIONS FOR EDWARDS NOZZLE

1. PHYSICAL PROPERTIES OF PROPELLANT GASES:

(according to K. Woodcock)

$$\mu = 5.862 \times 10^{-5} \frac{\text{lb (m)}}{\text{ft} \cdot \text{sec}}$$

$$c_p = 0.472 \frac{\text{BTU}}{\text{lb (m)} \cdot ^\circ\text{F}}$$

$$k = \mu \left[c_p + 1.25 \frac{R}{M_w} \right]$$

$$M_w = 27.0 \text{ g/mole}$$

$$k = 5.862 \times 10^{-5} \left[0.472 + (1.25) \left(\frac{0.037}{27.0} \right) \right]$$

$$k = 5.862 \times 10^{-5} \left[0.472 + 0.0092 \right]$$

$$k = 33 \times 10^{-5} \frac{\text{BTU}}{\text{ft} \cdot ^\circ\text{F} \cdot \text{sec}}$$

$$T_c = 3185 \text{ } ^\circ\text{K} \quad \text{or} \quad 5735 \text{ } ^\circ\text{R}$$

$$\frac{hD}{k} = 0.023 \left(\frac{DG}{\mu} \right)^{0.8} \left(\frac{c_p \mu}{k} \right)^{0.4}$$

(i) Dittus - Boelter equation
see McAdams "Heat Transmission", 3rd ed., pg 219

This equation was found to be accurate in numerous experiments by Aerojet, see:

- (1) S.L. Colver, "Experimental Determination of Solid Rocket Nozzle Heat Transfer Coefficient", "Proceedings of 5th AFBMD - STL Aerospace Symposium, Vol. II, Academic Press, 1966
- (2) S.S. Grover, "Analysis of Nozzle Heat Transfer Coefficient", AGC TM 113 SRP, 30 Apr 1959.
- (3) E.M. Sadownik, "Investigation of Materials Capabilities of Materials Systems in Solid Rocket Motors", Part I, WADC TR 59-602, Part II

CONFIDENTIAL

$$G = \frac{W}{\pi D^2/4} \quad (2)$$

$$W = C_w A_T P_c \quad (3)$$

Substituting and rearranging:

$$h = 0.023 \frac{C_w P_c D_T^{1.6}}{D^{1.8}} \cdot \frac{C_p^{0.4} k^{0.6}}{\mu^{0.4}} \quad (4)$$

For propellant used

$$C_w = 0.0064 \text{ lbm/lbf-sec}$$

and in motor

$$P_c = 500 \text{ psia}$$

$$D_T = 2.575 \text{ in}$$

Converting all data into hour-foot units, substituting in (4)

$$h = 0.023 \frac{23.1^{0.8} 72100^{0.8} 0.2145^{1.6}}{D^{1.8}} \cdot \frac{0.472^{0.4} 0.118^{0.6}}{0.211^{0.4}} \quad (5)$$

$$h = 675/D^{1.8} \quad (6)$$

when D is in inches, then

$$h = 5950/D^{1.8} \quad \frac{\text{BTU}}{\text{hr-ft}^2\text{-}^\circ\text{F}} \quad (7)$$

Because gas properties, C_p , k , and μ vary with temp. in this modified Pr number in such a manner as not to affect this Pr number by more than 5%, we can assume that this equation(?) is valid for entrance section, throat section and exit section heat transfer calculations.

CONFIDENTIAL

In heat transfer calculations of nozzle walls the "adiabatic wall" temperature is used as the temperature which is the driving potential. The adiabatic wall temperature is defined as

$$T_{aw} = N_{r_f} (T_s - T_m) + T_m$$

where T_s - is the "total" or "stagnation" temp
 T_m - is the moving-stream temperature
 and N_{r_f} - is the recovery factor (for turbulent boundary layer = $N_{Pr}^{1/3}$; where $Pr = \frac{c_p \mu}{k}$)

In the proposal we are told to assume as the total temperature is 5500-6000°F. We will use the higher value of 6000°F or 6460°R. The moving-stream gas temperature will be calculated from $T_s - T_m = V^2 / 2gc J c_p$ (ideal gas). The Pr is equal to $0.472 \times 5.862 \times 10^{-5} / 3.3 \times 10^{-5}$ or 0.839. The recovery factor is then 0.94

Position	A/A _t	T _m /T _s	T _m , °R	ΔT	T _{aw} , °R	T _{aw} , °F
1	1.182	.9635	6220	240	6445	5985
2	1.000	.9091	5875	585	6425	5965
3	1.182	.8223	5310	1150	6296	5836

CONFIDENTIAL

CONFIDENTIAL

Properties of Nozzle Material

$$K = 10 \text{ BTU/hr-ft-}^\circ\text{F}$$

$$\rho = 312 \text{ lb/ft}^3$$

$$C_p = 0.2 \text{ BTU/lb}$$

Ref. { Using NAVORD Report 5562, Temperature tables, Part 2, One-layer Cylindrical Shell, Internal Heating, One Space Variable, linear

for entrance, inside surface, no conduction past insert
 $r = r_i, h = 0$

$$r_o = 2.0 \text{ in.} = .166 \text{ ft}$$

$$r_i = 1.4 \text{ in.} = .1166 \text{ ft}$$

$$h_i = 910 \text{ BTU/hr-ft}^2\text{-}^\circ\text{F}$$

$$h_o = 0$$

$$K = 10 \text{ BTU/hr ft-}^\circ\text{F}$$

$$k = \frac{C_p \rho}{K} = \frac{0.2 \times 312}{10} = 6.24$$

$$t = 10 \text{ sec} \quad 30 \text{ sec} \quad 60 \text{ sec}$$

$$\tau = \frac{t}{r_o^2 k} = \frac{t}{.02775 \times 6.24 \times 3600} = \frac{t}{624} = 0.0016 t$$

$$\alpha = \frac{r - r_i}{r_o - r_i} = 0$$

$$\alpha_o = \frac{h_o r_o}{K} = 0$$

$$\alpha_i = \frac{h_i r_o}{K} = \frac{912 \times .167}{10} = 15.2$$

$$\alpha_1 = \frac{r_i}{r_o} = .673$$

$$t_{10} = 0.016$$

$$t_{30} = 0.048$$

$$t_{60} = 0.096$$

CONFIDENTIAL

for entrance, outside surface

$$r = r_0 \quad h_0 = 0$$

$$\alpha = \frac{r - r_i}{r_0 - r_i} = \frac{2.0 - 1.4}{2.0 - 1.4} = 1$$

$$\alpha_0 = 0 \quad \alpha_i = 15.2 \quad \alpha_1 = .673$$

\bar{r}	$\alpha_i (\alpha_i = .6)$		$\alpha_i (\alpha_i = .7)$		T_c $\alpha_i = .673$		
	10	40	10	40	10	15.2	40
.01	.002	.005	.020	.040	.015	.018	.031
.02	.031	.055	.110	.185	.049	.100	.150
.04	.145	.220	.310	.449	.263	.284	.387
.06	.265	.371	.470	.631	.414	.439	.561
.10	.461	.543	.688	.834	.627	.651	.769

$$T_w = 70^\circ + (5985 - 70) T_i$$

\bar{r}	t_b, sec	$T_w, ^\circ\text{F}$
.01	6.24	176
.02	12.48	661
.04	24.96	1750
.06	37.44	2665
.10	62.40	3917

CONFIDENTIAL

For Nozzle Throat, Inside Surface & Outside Surf.

$$r_o = 1.920 \text{ in} = .160 \text{ ft}$$

$$r_i = 1.287 \text{ in} = .1072 \text{ ft}$$

$$h_i = 1,100 \text{ BTU/hr-ft}^2\text{-}^\circ\text{F}$$

$$h_o = 0$$

$$\tau = \frac{t}{.0256 \times 6.27 \times 3600} \quad t = 575\tau$$

$$T_{aw} = 5965^\circ\text{F}$$

$$T_o = 70^\circ\text{F}$$

$$\alpha = 0 \quad \text{and} \quad \alpha = 1$$

$$\alpha_o = 0$$

$$\alpha_i = \frac{1100 \times .16}{10} = 17.6$$

$$\alpha_1 = 0.671$$

τ	t, sec	$\alpha_i (\alpha, z, 6)$		$\alpha_i (\alpha, z, 7)$		$T_w, ^\circ\text{F}$	$\alpha = .671$		
		10	40	10	40		10	17.6	40
0.01	5.75	.549	.849	.553	.851	3810	.552	.627	.850
0.02	11.5	.633	.886	.638	.889	4260	.637	.701	.888
0.04	23.0	.706	.915	.729	.927	4690	.723	.774	.924
0.06	34.5	.753	.933	.792	.951	4982	.781	.823	.946
0.10	57.5	.819	.957	.878	.978	5375	.861	.889	.972

OUTSIDE SURFACE

τ	t, sec	$\alpha_i (\alpha, z, 6)$		$\alpha_i (\alpha, z, 7)$		$T_w, ^\circ\text{F}$	$\alpha = .671$		
		10	40	10	40		10	17.6	40
.01	5.75	.007	.005	.020	.040	183	.015	.019	.030
.02	11.5	.031	.055	.110	.185	645	.077	.095	.147
.04	23.0	.145	.220	.310	.449	1813	.262	.293	.383
.06	34.5	.265	.371	.470	.631	2775	.409	.446	.556
.10	57.5	.461	.593	.688	.834	3988	.632	.658	.764

CONFIDENTIAL

ASSUME NOZZLE THROAT MATERIAL
HAS $K = 20$ BTU/hr-ft-°F

$\alpha_i = \infty$

$t = 2875 \mu$

HOT SIDE τ	t, sec.	$\alpha_i = .6$		$\alpha_i = .7$		$\alpha_i = .671$			$T_w, ^\circ F$
		α_i		α_i		α_i			
		$\frac{4}{t}$	$\frac{10}{t}$	$\frac{4}{t}$	$\frac{10}{t}$	$\frac{4}{t}$	$\frac{8}{t}$	$\frac{10}{t}$	
.01	2.9	.311	.549	.314	.552	.313	.504	.551	3150
.02	5.8	.388	.632	.393	.638	.391	.587	.636	3572
.04	11.5	.470	.708	.488	.728	.483	.675	.722	4100
.06	17.2	.524	.753	.567	.792	.552	.735	.781	4460
.10	29	.609	.841	.679	.877	.659	.820	.860	4965
.20	57.5	.760	.917	.952	.967	.825	.927	.952	5605

	t	$\alpha_i = .6$		$\alpha_i = .7$		$\alpha_i = .671$			$T_w, ^\circ F$
		α_i		α_i		α_i			
		$\frac{4}{t}$	$\frac{10}{t}$	$\frac{4}{t}$	$\frac{10}{t}$	$\frac{4}{t}$	$\frac{8}{t}$	$\frac{10}{t}$	
2.9		.001	.002	.010	.020	.009	.014	.015	150
5.8		.016	.031	.060	.110	.047	.081	.090	530
11.5		.085	.146	.187	.310	.157	.237	.269	1485
17.2		.165	.264	.304	.470	.261	.380	.410	2335
29.0		.312	.464	.490	.688	.440	.588	.625	3577
57.5		.576	.752	.765	.917	.710	.837	.869	5062

CONFIDENTIAL

CONFIDENTIAL

APPENDIX II

STRESS - ANALYSIS OF COMBUSTION

IMPULSE CARBIDE NOZZLE

CONFIDENTIAL

CONFIDENTIAL

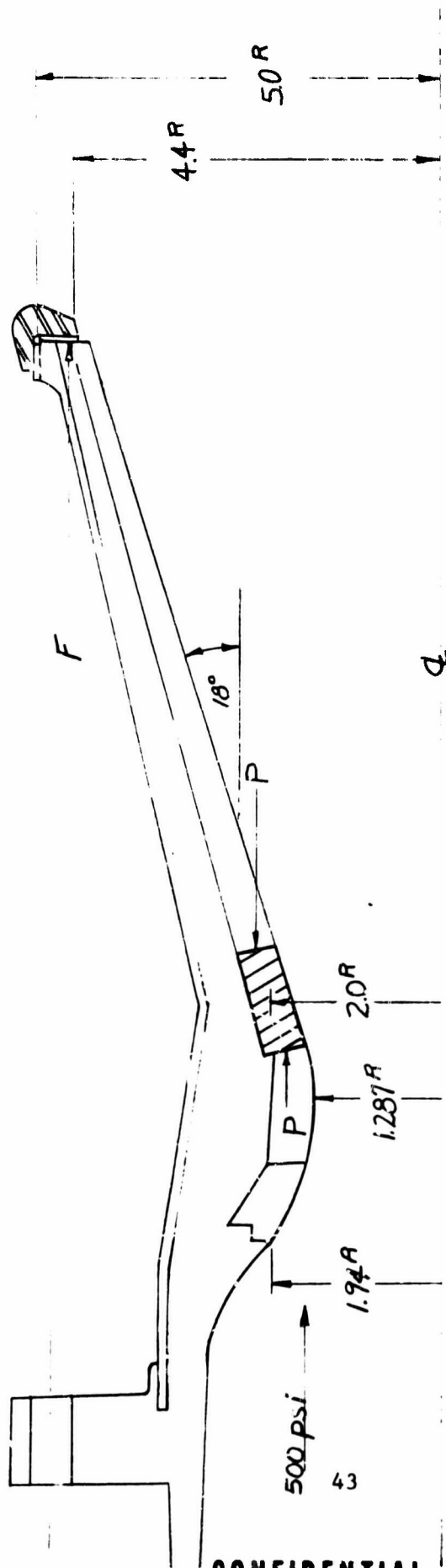

$$F = \frac{500 (1.94^2 - 1.287^2)}{2 \times 4.4} = 120 \text{ #/in}$$

Total Load on Ring, $V = 120 \times 8.8\pi = 3320\#$

$$P = \frac{3320}{2 \times 2\pi} = 264 \text{ #/in Force on First Insert Downstream}$$

CONFIDENTIAL

CONFIDENTIAL

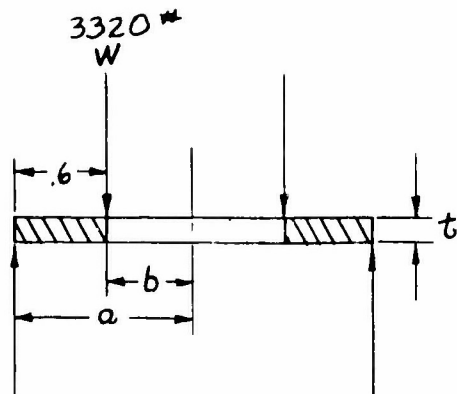

ROARK X - 14

$$\frac{a}{b} = \frac{5}{4.4} = 1.135$$

$$\beta = 1.1 \text{ (-) (Tangential)}$$

$$t^2 = \frac{1.1 \times 3.32}{25} = .146$$

5000 psi

$$t = .382'' \text{ (Conservative)}$$

Alternate Way

(TIMOSHENKO II)
$$t^2 = \frac{6 \times 120 \times .6 \times 4.7}{25000 \times 4.4 \ln 1.135} = .146$$

$$t = .382''$$

ROARK X-18

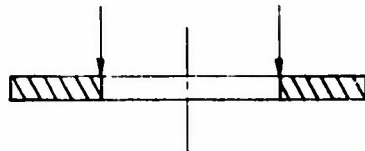

For Radial (max.) stress

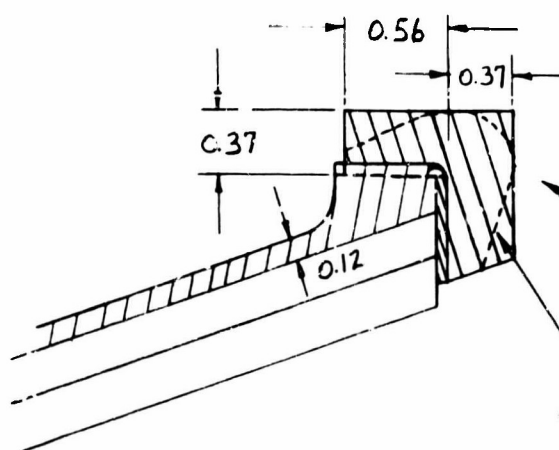

$$t = .382 \sqrt{\frac{.195}{1.1}} = .161$$

Suggested Dimensions

Outline Optional

CONFIDENTIAL

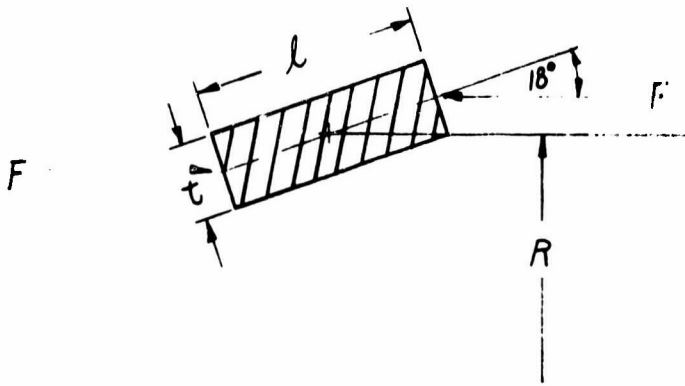

$$F = \frac{3320}{2K7} = \frac{528}{K}$$

Approx. Bending Stress

$$\sigma_B = \frac{12 FR \frac{l^2}{2} \sin \alpha}{l^3 t} = \frac{528 \times 6}{lt} \sin 18^\circ = \frac{983}{lt}$$

lt	σ_B	R	σ_c	σ_{max}
$1.4 \times .6 = .84$	1168	2	$\frac{528}{2 \times .6} = 440$	-1608
$1.8 \times .5 = .9$	1090			
$2.8 \times .4 = 1.12$	875			
$3.4 \times .3 = 1.02$	961			

This stress is highest in insert 1.

CONFIDENTIAL

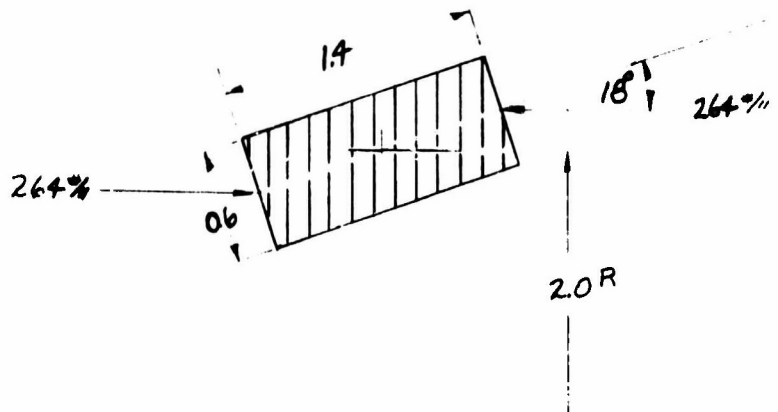

Approximate Bending Stress

$$\frac{6 \times 2 \times 264 \times 1.4 \sin 18^\circ}{1.4^2 \times .6} = \pm 1168$$

Approximate Compression $\frac{264}{.6} = -440$

Maximum Stress -1608 psi (Compression)
+728 psi (Tension)

CONFIDENTIAL

Security Classification

DOCUMENT CONTROL DATA - R&D		
<small>(Security classification of title, body of abstract and indexing annotation must be entered when the overall report is classified)</small>		
1. ORIGINATING ACTIVITY (Corporate author) Atlantic Research Corporation Alexandria, Virginia		2a. REPORT SECURITY CLASSIFICATION CONFIDENTIAL
		2b. GROUP Group 4
3. REPORT TITLE Evaluation of Columbium Carbide Nozzles for Solid Propellant Rocket Motors		
4. DESCRIPTIVE NOTES (Type of report and inclusive dates) Final Technical Report		
5. AUTHOR(S) (Last name, first name, initial) Olcott, Eugene L.		
6. REPORT DATE June 1966	7a. TOTAL NO. OF PAGES 46	7b. NO. OF REFS 4
8a. CONTRACT OR GRANT NO. AF 04(611)-8009	8a. ORIGINATOR'S REPORT NUMBER(S)	
b. PROJECT NO.		
c.	8b. OTHER REPORT NO(S) (Any other numbers that may be assigned this report)	
d.		
10. AVAILABILITY/LIMITATION NOTICES Qualified requestors may obtain copies of this report from DDC.		
11. SUPPLEMENTARY NOTES		12. SPONSORING MILITARY ACTIVITY Air Force Rocket Propulsion Laboratory Edwards Air Force Base, California 93523
13. ABSTRACT Two replicate columbium carbide nozzles were designed and fabricated. They were tested at the Rocket Propulsion Laboratory in the 5,000 pound solid-propellant char motor. Although minor difficulties occurred at the attachment fitting because of a subsequent change in test vehicle, the performance of the refractory carbide material from a standpoint of thermal shock resistance was excellent. The erosion performance was also good.		

DD FORM 1473
1 JAN 64

CONFIDENTIAL

Security Classification

Security Classification

14.	KEY WORDS	LINK A		LINK B		LINK C	
		ROLE	WT	ROLE	WT	ROLE	WT

INSTRUCTIONS

1. **ORIGINATING ACTIVITY:** Enter the name and address of the contractor, subcontractor, grantee, Department of Defense activity or other organization (*corporate author*) issuing the report.

2a. **REPORT SECURITY CLASSIFICATION:** Enter the overall security classification of the report. Indicate whether "Restricted Data" is included. Marking is to be in accordance with appropriate security regulations.

2b. **GROUP:** Automatic downgrading is specified in DoD Directive 5200.10 and Armed Forces Industrial Manual. Enter the group number. Also, when applicable, show that optional markings have been used for Group 3 and Group 4 as authorized.

3. **REPORT TITLE:** Enter the complete report title in all capital letters. Titles in all cases should be unclassified. If a meaningful title cannot be selected without classification, show title classification in all capitals in parenthesis immediately following the title.

4. **DESCRIPTIVE NOTES:** If appropriate, enter the type of report, e.g., interim, progress, summary, annual, or final. Give the inclusive dates when a specific reporting period is covered.

5. **AUTHOR(S):** Enter the name(s) of author(s) as shown on or in the report. Enter last name, first name, middle initial. If military, show rank and branch of service. The name of the principal author is an absolute minimum requirement.

6. **REPORT DATE:** Enter the date of the report as day, month, year; or month, year. If more than one date appears on the report, use date of publication.

7a. **TOTAL NUMBER OF PAGES:** The total page count should follow normal pagination procedures, i.e., enter the number of pages containing information.

7b. **NUMBER OF REFERENCES:** Enter the total number of references cited in the report.

8a. **CONTRACT OR GRANT NUMBER:** If appropriate, enter the applicable number of the contract or grant under which the report was written.

8b, 8c, & 8d. **PROJECT NUMBER:** Enter the appropriate military department identification, such as project number, subproject number, system numbers, task number, etc.

9a. **ORIGINATOR'S REPORT NUMBER(S):** Enter the official report number by which the document will be identified and controlled by the originating activity. This number must be unique to this report.

9b. **OTHER REPORT NUMBER(S):** If the report has been assigned any other report numbers (*either by the originator or by the sponsor*), also enter this number(s).

10. **AVAILABILITY/LIMITATION NOTICES:** Enter any limitations on further dissemination of the report, other than those

imposed by security classification, using standard statements such as:

- (1) "Qualified requesters may obtain copies of this report from DDC."
- (2) "Foreign announcement and dissemination of this report by DDC is not authorized."
- (3) "U. S. Government agencies may obtain copies of this report directly from DDC. Other qualified DDC users shall request through _____."
- (4) "U. S. military agencies may obtain copies of this report directly from DDC. Other qualified users shall request through _____."
- (5) "All distribution of this report is controlled. Qualified DDC users shall request through _____."

If the report has been furnished to the Office of Technical Services, Department of Commerce, for sale to the public, indicate this fact and enter the price, if known.

11. **SUPPLEMENTARY NOTES:** Use for additional explanatory notes.

12. **SPONSORING MILITARY ACTIVITY:** Enter the name of the departmental project office or laboratory sponsoring (*paying for*) the research and development. Include address.

13. **ABSTRACT:** Enter an abstract giving a brief and factual summary of the document indicative of the report, even though it may also appear elsewhere in the body of the technical report. If additional space is required, a continuation sheet shall be attached.

It is highly desirable that the abstract of classified reports be unclassified. Each paragraph of the abstract shall end with an indication of the military security classification of the information in the paragraph, represented as (TS), (S), (C), or (U).

There is no limitation on the length of the abstract. However, the suggested length is from 150 to 225 words.

14. **KEY WORDS:** Key words are technically meaningful terms or short phrases that characterize a report and may be used as index entries for cataloging the report. Key words must be selected so that no security classification is required. Identifiers, such as equipment model designation, trade name, military project code name, geographic location, may be used as key words but will be followed by an indication of technical context. The assignment of links, rules, and weights is optional.