

UNCLASSIFIED

AD NUMBER

AD384744

CLASSIFICATION CHANGES

TO: UNCLASSIFIED

FROM: CONFIDENTIAL

LIMITATION CHANGES

TO:
Approved for public release; distribution is unlimited.

FROM:
Distribution authorized to U.S. Gov't. agencies and their contractors; Critical Technology; OCT 1967. Other requests shall be referred to Army Missile Command, Redstone Arsenal, AL 35809. This document contains export-controlled technical data.

AUTHORITY

USAMICOM ltr dtd 1 Feb 1974 USAMICOM ltr dtd 1 Feb 1974

THIS PAGE IS UNCLASSIFIED

SECURITY

MARKING

The classified or limited status of this report applies to each page, unless otherwise marked.

Separate page printouts MUST be marked accordingly.

THIS DOCUMENT CONTAINS INFORMATION AFFECTING THE NATIONAL DEFENSE OF THE UNITED STATES WITHIN THE MEANING OF THE ESPIONAGE LAWS, TITLE 18, U.S.C., SECTIONS 793 AND 794. THE TRANSMISSION OR THE REVELATION OF ITS CONTENTS IN ANY MANNER TO AN UNAUTHORIZED PERSON IS PROHIBITED BY LAW.

NOTICE: When government or other drawings, specifications or other data are used for any purpose other than in connection with a definitely related government procurement operation, the U. S. Government thereby incurs no responsibility, nor any obligation whatsoever; and the fact that the Government may have formulated, furnished, or in any way supplied the said drawings, specifications, or other data is not to be regarded by implication or otherwise as in any manner licensing the holder or any other person or corporation, or conveying any rights or permission to manufacture, use or sell any patented invention that may in any way be related thereto.

CONFIDENTIAL

October 1967

Technical Report S-145

**BALLISTIC SCALE-UP OF NF PROPELLANTS
V. DEMONSTRATION FIRINGS IN TACTICAL CONFIGURATIONS (U)**

by

S. E. Anderson

U. S. ARMY MISSILE COMMAND
Redstone Arsenal, Alabama 35809

Contract Nos.
DA-01-021 AMC-13864(Z)
DAAH01-67-C-0947

Distribution Limited

"This document contains information affecting the National Defense of the United States within the meaning of the Espionage Laws, Title 18, U. S. C., Section 793 and 794. Its transmission or the revelation of its contents in any manner to an unauthorized person is prohibited by law."

ROHM AND HAAS COMPANY

REDSTONE RESEARCH LABORATORIES

HUNTSVILLE, ALABAMA 35807

STATEMENT #2 CLASSIFIED

In addition to security requirements which must be met, this document is subject to special export controls and each transmittal to foreign governments or foreign nationals may be made only with prior approval of HQ. U.S. ARMY MISSILE COMMAND

REDSTONE ARSENAL, ALABAMA

35809

CONFIDENTIAL

PRECEDING PAGE BLANK- NOT FILMED.

(U) FOREWORD

The work described in this report was performed under Contracts DA-01-021 AMC-13864(Z) and DAAH01-67-C-0947 for exploratory development of *solid propulsion* technology for missiles and rockets under the cognizance of the Army Propulsion Laboratory and Center, Research and Development Directorate, U. S. Army Missile Command.

The participation of Mr. Bernard L. Thompson in the Redeye demonstration phase is gratefully acknowledged.

CONFIDENTIAL

(C) ABSTRACT

The adaptability of high-energy NF propellants was demonstrated in three short-term development programs. The TOW launch motor, the LAW motor, and the Redeye sustainer motor were used as examples of current systems to show the utility of the unique properties of NF propellants. These properties (i. e., high burning rate, high specific impulse, good high-pressure ballistics) will be useful in designing future systems.

Using NF propellant, a case-bonded, slotted-tube grain in the TOW launch-motor configuration met all original specifications. The action time at -25°F was 0.043 seconds (0.009 seconds shorter than specified) and the total impulse was 290 lbf-sec (3½% over the target). Propellant performance was slightly better than predicted; burning rate was 8.4 in./sec at 3266 psia, and specific impulse was 245 lbf-sec/lbm at motor conditions. The variation in motor operating pressure with temperature was half that of the tactical unit with M-7 propellant. It was concluded that NF propellants will have real utility in short-burning-time motors.

In another demonstration of the good high-pressure ballistics of NF propellant, a case-bonded wagonwheel grain which was cast in an aluminum LAW case duplicated the performance of the tactical motor at 77°F in almost every respect. The specific impulse delivered by the NF propellant was 265 lbf-sec/lbm, compared with 241 for the M-7 in the tactical LAW. Thrust action time was 0.007 seconds.

The Redeye demonstration motors were made using a new technique for casting end-burning grains directly in a motor case. Acrylic copolymer lacquers on butyl rubber restrictor provided excellent bonding for the propellant. NF propellants had burning rates which eliminated the need for augmentation by wires, such as is done in the operational version. The NF motors gave a 19% increase in total impulse while maintaining about the same thrust and pressure levels.

The improved performance and new manufacturing techniques make this propellant system attractive for use in future air-defense systems.

(U) CONTENTS

| | <u>Page</u> |
|--|-------------|
| Foreword | iii |
| Abstract | iv |
| Section I. INTRODUCTION | 1 |
| Section II. SHOULDER-FIRED ROCKETS | 2 |
| 1. Background | 2 |
| 2. TOW Launch Motor | 3 |
| a. Ballistic Requirements and Tactical Motor | 3 |
| b. Early Work with PNC Propellants | 3 |
| c. Characteristics of RH-SE-182ai Propellant | 3 |
| d. Description of Case-Bonded NF Grain and Firing Hardware | 6 |
| e. Results of Firings | 8 |
| 3. Replacement Motor for LAW | 13 |
| 4. Discussion of Problems | 16 |
| Section III. SUSTAINERS FOR AIR-DEFENSE MISSILES | |
| 1. Description of Redeye Sustainer Motor | 17 |
| 2. Propellant and Liner Tailoring | 17 |
| 3. Results of Firings | 20 |
| Section IV. CONCLUSIONS | 25 |
| References | 27 |
| Glossary | 29 |

CONFIDENTIAL

Section I. (C) INTRODUCTION

(C) Over the past several years, the formulation and scale-up of propellants based on NF binders have been primary efforts at these Laboratories. Extensive studies of ballistic and mechanical properties have demonstrated that the propellants formulated with ammonium perchlorate and aluminum have high energy, high density, a combination of tensile strengths and elongations that are usable over a wide temperature range, and that NF propellants should be acceptable for field use (1, 2, 3, 4, 5).¹ These propellants have several unique properties: for example, the burning rates are higher than those of unmodified carboxyl-terminated polybutadiene (CTPB) propellants or equivalent to those achieved in composite-modified double-base (CMDB) propellants with metal fibers. In addition, the exponent of pressure in the burning-rate equation is constant at 0.6 to pressures greater than 30,000 psia in NF propellants containing small particle-size ammonium perchlorate ($D_m^{50} = 8$ to 15μ). In spite of the relatively high pressure exponent, the propellants have π_K values of $0.13\%/F^\pi$, which is near that for CTPB propellants.

(U) There has been a continuing effort to find applications in which these properties could be used to advantage. An early study showed that the intrinsic burning rates are too high for the current Pershing and Minuteman with center-perforated grains but match the requirements for high-thrust, short-duration units such as boosters for close-support artillery, boosters for air-defense missiles, and launch motors for shoulder-fired rockets. The propellants can also be used in end-burning rockets which require high burning rates (6).

(U) This report presents results of three short-term experimental programs that demonstrated the utility of NF propellants. The configurations used were the LAW motor, the TOW launch motor, and the Redeye sustainer; the burning times ranged from 0.006 to 6 sec. In addition, the Redeye program utilized a new technology for producing end-burning charges (7).

¹Numbers in parentheses indicate references at the end of the report.

CONFIDENTIAL

CONFIDENTIAL

Section II. (C) SHOULDER-FIRED ROCKETS

1. (C) Background

(U) Several tactical anti-tank rockets are fired from the shoulder of an infantryman using a simple tube as a launcher. The booster for this type of missile must perform with a high degree of reliability and must burn out before it exits from the launch tube. This latter requirement places stringent demands on the propulsion unit: (1) to reach the required velocity in the length of the tube, the acceleration of the missile must be extremely high; (2) to provide the high acceleration, small-diameter motors must generate very high thrust levels; (3) to obtain these high thrust levels, the motors must operate at high pressures.

(U) For about 20 years, these conditions have been met using rocket motors containing a multiple-grain charge of tubular M-7 propellant.² No propellant burned fast enough to allow the design of a simple, case-bonded charge for this type of weapon. In addition, propellants containing ammonium perchlorate could not be used because the exponent of pressure in the burning-rate equation was equal to or greater than 1 in the pressure regime in which tube-launched rockets normally operate (8). Thus, the advantages of modern propellant technology such as improved temperature sensitivity, higher specific impulse, and higher density could not be utilized in shoulder-fired rockets.

(C) Motors using conventional CTPB and CMDB propellants were limited to pressures below 4,000 to 6,000 psia to avoid pressure exponents greater than 1. NF propellants containing finely-ground ammonium perchlorate were found to burn reliably and controllably at pressures above 20,000 psia and gave rates of 10 in/sec at 10,000 psia. (6, 8) This opened up the possibility of significant improvements in motors for high-acceleration weapons. The combination of high specific impulse, high density, and high burning rate of NF propellants made it possible to use a case-bonded star or hollow-cylinder grain to replace a many-spoked wagonwheel or multiple-grain charge (6). Because shoulder-fired rockets represent the extreme in high-acceleration rocket technology (except for rocket-assisted projectiles) and little improvements in the field had been made for some time, this area was chosen for experimental investigation.

²Unit 1072, CPIA/M2 Solid Propellant Manual.

CONFIDENTIAL

2. (C) TOW Launch Motor

a. (C) Ballistic Requirements and Tactical Motor

(C) The TOW launch motor has requirements significantly less demanding than those of the early bazookas but which still are beyond the capabilities of conventional propellants in case-bonded charges. The TOW missile weighs 30 pounds and is accelerated to 150 ft/sec in a 6-ft. tube. From the original requirements the motor thrust was about 7000 lbf with a thrust action time of 0.052 seconds at -25°F. The total impulse desired was 280 lbf-sec, and the missile acceleration was about 350 g. The tactical version uses four rather large sticks of M-7 propellant in a 2-inch X 15-inch case (Figure 1a). Because of the high temperature sensitivity of M-7, the specifications have been relaxed slightly to allow longer burning times at -25°F.

b. (U) Early Work with PNC Propellants

An alternate approach, investigated at these Laboratories, used fast-burning plastisol-nitrocellulose composite (PNC) propellant in a case-bonded charge. The operating pressure could be no higher than 4000 psia because the pressure exponent increased at higher pressures, and this limited the burning rate obtainable to 1.65 in/sec. The grain design required was a 16-point wagonwheel (Figure 1b). This grain was too fragile to withstand the stresses of firing at high temperature (9).

With NF propellant, no limitation on operating pressure existed, and the burning-rate capability was more than triple that of the PNC propellant. A slotted-tube grain (Figure 1c) appeared feasible for this application.

c. (C) Characteristics of RH-SE-182ai Propellant

(C) This NF propellant contained 8 μ ammonium perchlorate and had a 3/1 ratio of TVOPA to NFPA in the binder (Table I). This gave a burning rate of 2.1 in/sec at 1000 psia with a pressure exponent of 0.6 (Figure 2). The high ratio of plasticizer to polymer gave a relatively weak propellant, with a high-temperature strength of only 41 psi (Table II). However, analysis of the gas dynamic and acceleration loads imposed on the slotted-tube grain indicated that this tensile strength was adequate.

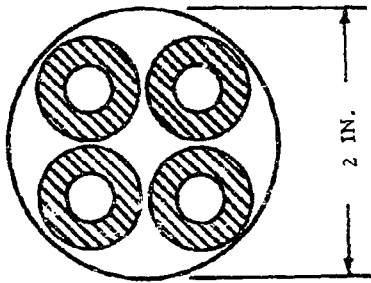

A. TUBULAR
M-7 CHARGE

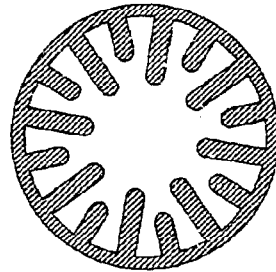

B. FLASTISOL
PROPELLANT
CHARGE

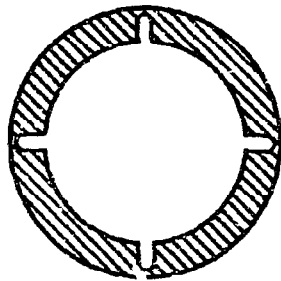

C. NF PROPELLANT
CHARGE

FIGURE 1. (U) COMPARISON OF TOW GRAIN DESIGNS

CONFIDENTIAL

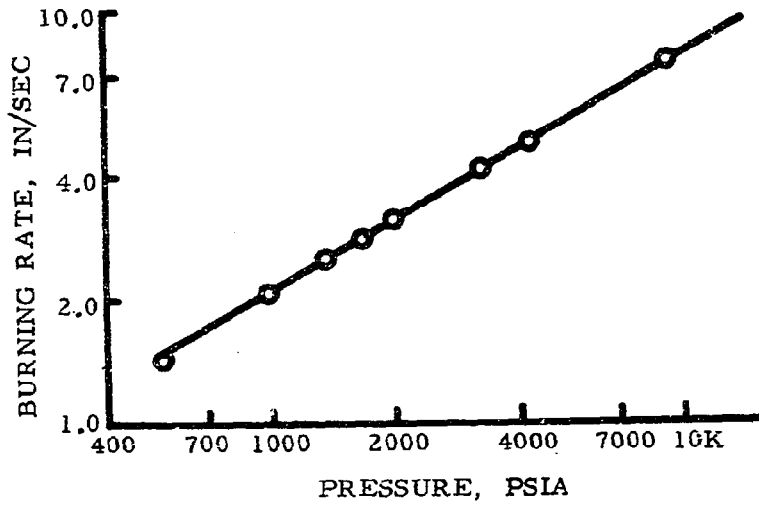

FIGURE 2. (C) BURNING RATE OF RH-SE-182ci(U)

CONFIDENTIAL

CONFIDENTIAL

| Table I. (C) Formulation of RH-SE-182ai Propellant | | |
|--|----------------------|--------------|
| Ingredient | Function | Wt. % |
| NFPA | Energetic binder | 10.45 |
| Acrylic acid | Functional comonomer | 0.55 |
| TVOPA | Plasticizer | 33.00 |
| Ammonium perchlorate (8 μ) ^a | Oxidizer | 55.00 |
| Aluminum (3 μ) ^b | Fuel | 1.00 |
| Unox ^c 221 | Crosslinker | 1.42 (added) |

^a Coated with 1% Alumina-C; Degussa, Inc., Kearny, N. J.
^b Alcoa 140; Aluminum Company of America, Pittsburgh, Pa.
^c Trademark of Union Carbide Corporation, New York, N. Y.

| Table II. (U) Mechanical Properties of RH-SE-182ai Propellant ICRPG Specimens Tested at 2 in/min. | | | |
|--|-----------------|------|------|
| Property | Temperature, °F | | |
| | -40 | +77 | +140 |
| Maximum engineering stress, psi | 375 | 66 | 41 |
| Strain at max. stress, in/in | 0.29 | 0.45 | 0.48 |

(U) The standard theoretical specific impulse (I_{sp}^0) of RH-SE-182 was 265 lbf-sec/lbm; the density was 0.065 lbm/in³, and the temperature sensitivity at constant K (w_K) was 0.20 %/F° measured in 2-inch motors. Specific impulse efficiency in these small motors was over 95%.

d. (U) Description of Case-Bonded NF Grain and Firing Hardware

Tests were carried out using 15-inch-long workhorse motors made from hydraulic cylinder tubing having a 2-inch inside diameter. The propellant charge had an outside diameter of 2.0 inches, an inside diameter of 1.52 inches, a length of 15 inches, and four slots 4.5 inches long. Existing firing hardware fit the motor cases, and all-steel nozzles were fabricated for the tests (Figure 3). The optimum

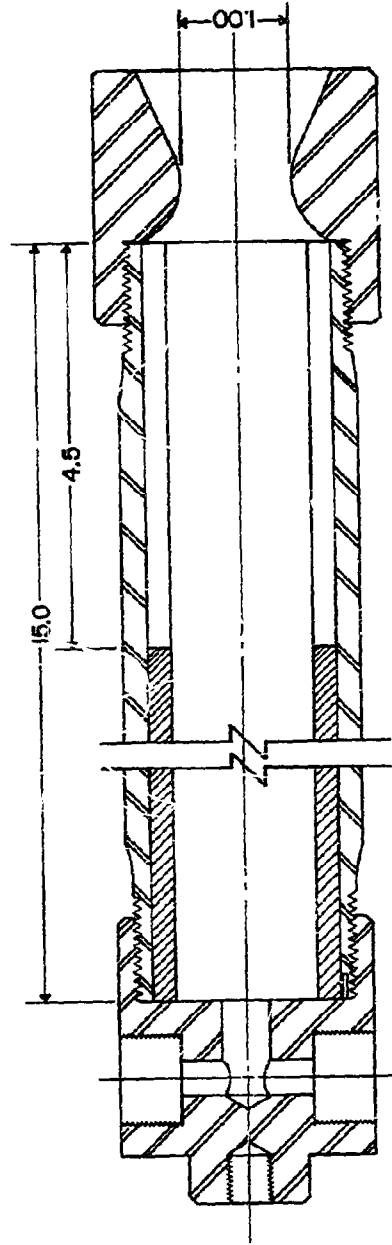

FIGURE 3. (U) FIRING AND GRAIN CONFIGURATION FOR LAUNCH MOTOR TESTS

CONFIDENTIAL

nozzle design had a 31° divergence half-angle. Cases were prepared for casting by gritblasting and vapor degreasing. No liner was necessary for either insulating or bonding; the motor burning time was too short to cause significant heating of the case, and the propellant bond to bare steel was adequate for the demonstration. Bonding lacquers based on acrylic copolymers are now available for use in this type of application (4). Smokeless igniters were made from three 5-gm bags of type-B Fluid Ball^{® 3} powder and a heavy plastic nozzle closure was used to obtain a rapid pressure rise. Earlier reports have contained limited experimental data from firings of this motor with two early NF propellants which used different binder/curing agent systems (1, 6). However, this report presents the results from a larger number of motors which were fired under controlled conditions.

e. (C) Results of Firings

(C) Eight motors were tested successfully in the experimental program. One was used for ignition verification and one for nozzle sizing; the data from these are not included here. The remaining six were fired at temperatures of 77°, 135°, and -25°F. Pressure-time curves were smooth, and ignition and tailoff were rapid (Figure 4). The data summary (Table III) shows that there were relatively small variations in ballistic parameters over the 160°F temperature range. Burning pressure ranged from 9455 psia at 135°F to 7112 psia at -25°F, which is a decrease of only 25%. The action time at -25°F (0.045 seconds) was only 0.013 seconds longer than the action time at 135°F, and was well under the original specification of 0.052 seconds. Since the delivered specific impulse was greater than 242 lbf-sec/lbm at every condition, the original total impulse specification of 280 lbf-sec/lbm was exceeded by 3.5%.

(C) Comparison with the tactical version shows improvement in almost every area. The variation in pressure with temperature is about half that of the M-7 round (Figure 5), and the variation in thrust action time with temperature is also significantly lower with the NF motor (Figure 6). The action time of the M-7 motor exceeds the original specification. The total impulse delivered by the M-7 motor is slightly lower than the original requirement of 280 lbf-sec, and is almost 10% below the performance of the NF round (Table IV). The increased pressure of the NF motors is well within the design capabilities of the tactical TOW launch motor case, because the case was designed for the high pressures obtained at 145°F with the M-7 propellant. Launch motors have been tested successfully at over 15,000 psia.

³Trademark of Olin Mathieson Chemical Corporation, New York, N. Y.

CONFIDENTIAL

| Table III. (U) Results from Firings of TOW Launch Motors Made with NF Propellant | | | | | | | |
|---|------------------|------------|-------------------------|-------------------------|-------------------------|----------------------|-------------|
| A. Pressure Data | | | | | | | |
| Round No. | Test Temp. (°F) | K_n | \bar{P}_b (psia) | \bar{r}_b (in/sec) | t_b (sec) | \bar{P}_a (psia) | t_a (sec) |
| 7851 | +77 | 105.0 | 8727 | 8.4 | 0.028 | 6704 | 0.041 |
| 7912 | +77 | 103.7 | 8266 | 8.4 | 0.028 | 5797 | 0.044 |
| 7913 | +77 | 105.0 | 9470 | 8.8 | 0.027 | 7230 | 0.038 |
| 7852 | +135 | 104.2 | 9455 | 9.4 | 0.025 | 8292 | 0.032 |
| 8000 | -25 | 103.3 | 7669 | 7.1 | 0.033 | 5974 | 0.045 |
| 8034 | -25 | 103.6 | 7112 | 7.3 | 0.032 | 5690 | 0.043 |
| B. Thrust Data (Nozzles had 31° divergence half-angles) | | | | | | | |
| Round No. | Prop. Mass (lbm) | ϵ | Total Impulse (lbf-sec) | I_{spd} (lbf-sec/lbm) | I_{sps} (lbf-sec/lbm) | Maximum Thrust (lbf) | |
| 7851 | 1.19 | 3.960 | 293.6 | 246.2 | 262.6 | 9,981 | |
| 7912 | 1.19 | 3.919 | 289.9 | 244.0 | 260.4 | 10,336 | |
| 7913 | 1.20 | 4.008 | 294.7 | 245.7 | 261.2 | 10,735 | |
| 7852 | 1.20 | 3.929 | 294.5 | 245.5 | 261.4 | 11,736 | |
| 8000 | 1.19 | 3.941 | --- | --- | --- | --- | |
| 8034 | 1.19 | 3.957 | 291.9 | 242.3 | 258.6 | 9,828 | |

| Table IV. (C) Performance Comparison of NF Launch Motor With Tactical Version at 77°F | | |
|--|------------------------------|-----------------------------|
| | Tactical: M-7 Double-Base | Prototype: NF Propellant |
| Propellant mass, lbm | 1.07 | 1.19 |
| Average pressure, psia | 6200 | 8700 |
| Maximum pressure, psia | 7500 | 9100 |
| Thrust action time, sec | 0.038 | 0.036 |
| Total impulse, lbf-sec | 265 | 293 |

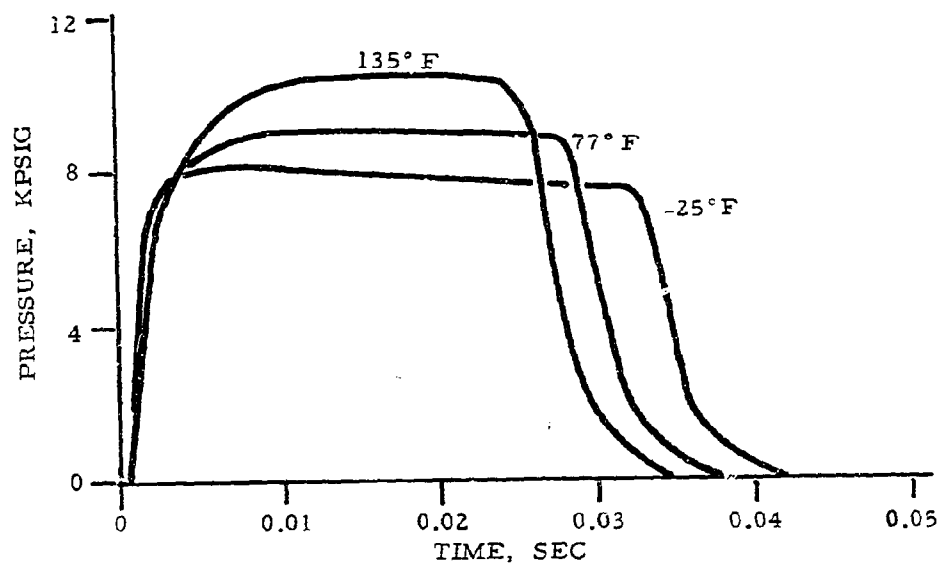

FIGURE 4. (U) REPRESENTATIVE PRESSURE TRACES FROM NF TOW LAUNCH MOTOR FIRINGS

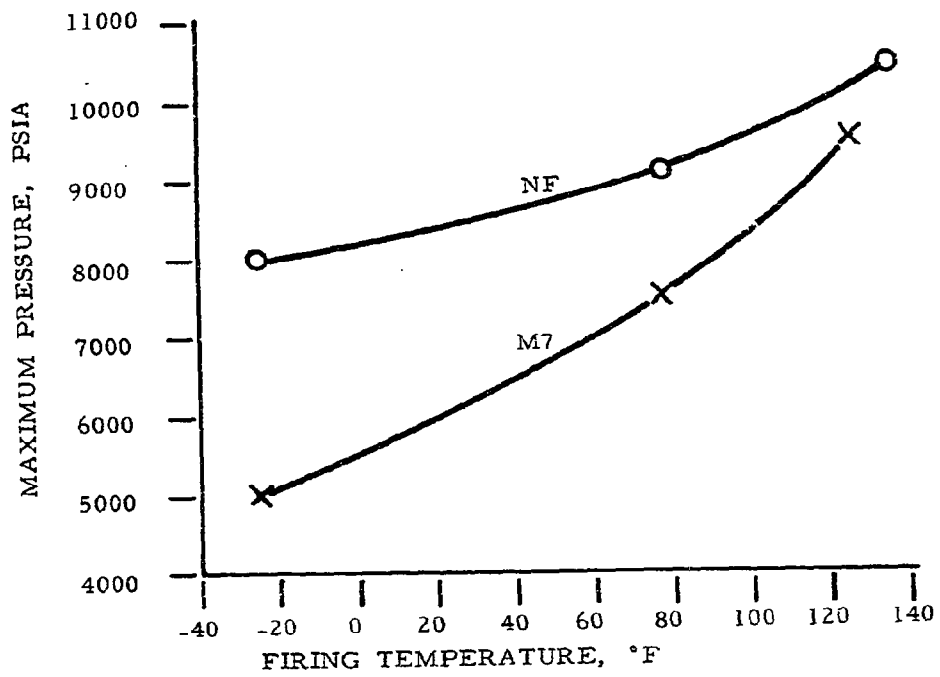

FIGURE 5. (U) TEMPERATURE SENSITIVITY OF TOW LAUNCH MOTOR

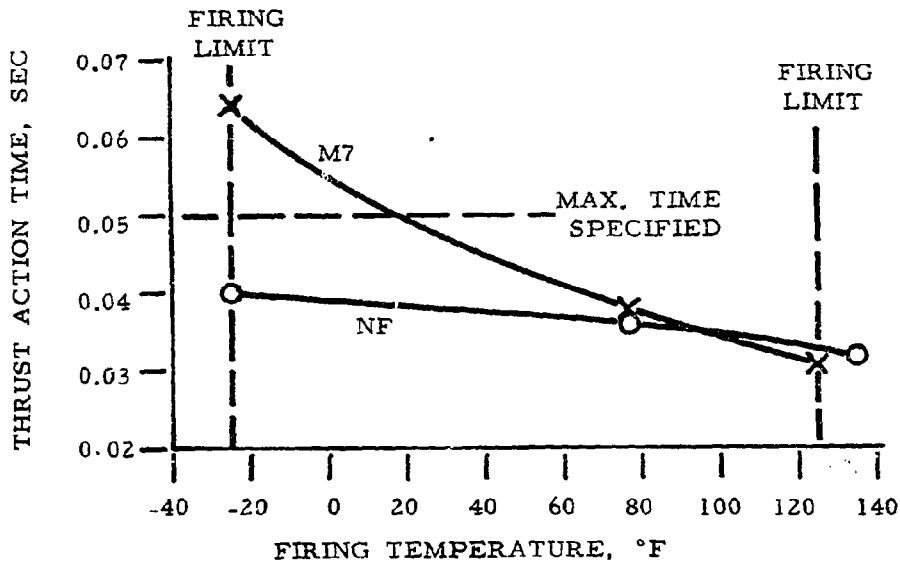

FIGURE 6. (U) SPECIFIED OPERATING CHARACTERISTICS OF TOW LAUNCH MOTOR

CONFIDENTIAL

3. (C) Replacement Motor for LAW

(U) The present M-72 anti-tank weapon (better known as the LAW) is also a short-burning, high-thrust, shoulder-fired rocket. It, too, uses a head-end suspended, multiple-grain charge of M-7 stick propellant. Nineteen tubular grains of propellant totalling 0.134 pound accelerate the warhead at 2600 g to a muzzle velocity of 490 ft/sec in a burning time (t_b) of 0.006 seconds. These specifications are such that a slotted-tube grain for NF propellant could not be made. However, a relatively fragile wagonwheel grain has been designed using the properties of RH-SE-182ai propellant (Figure 7). While this propellant was adequate for use in the TOW launch motor, the wagonwheel grain would probably not withstand the acceleration of the LAW without improvement in propellant strength.

(C) One of these grains was cast into a tactical aluminum case. A very thin acrylic copolymer lacquer was used as a case-bonding medium. When the motor was tested, extremely good agreement with the performance of the tactical weapon was obtained (Table V, Figure 8). This also demonstrated the predictability of NF propellants.

| | Tactical: M-7 Double-Base | Prototype: NF Propellant |
|--|------------------------------|-----------------------------|
| Propellant mass, lbm | .0134 | 0.124 |
| Maximum pressure, psia | 6000 | 6100 |
| Ignition action time, sec | 0.009 | 0.007 |
| Total impulse, lbf-sec | 31 | 33 |
| Delivered specific impulse, lbf-sec/lbm | 241 | 265 |

(C) In later work, burning rates 25% higher than those available with 8 μ AP have been attained with 4 μ AP. This makes possible a reduction in grain complexity for the LAW application. The use of other plasticizers having higher energy and more NF₂ groups would give additional increases in burning rates, but the advantage of improved temperature sensitivity would probably be lost (10).

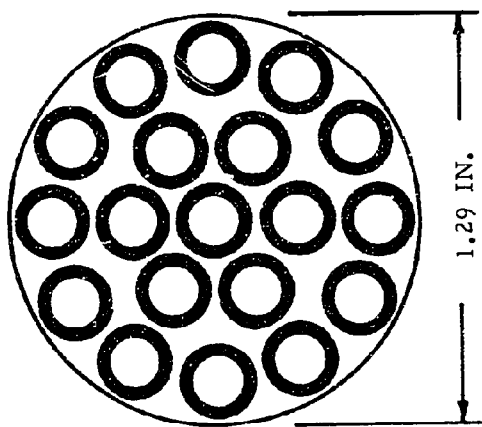

TUBULAR M7 CHARGE

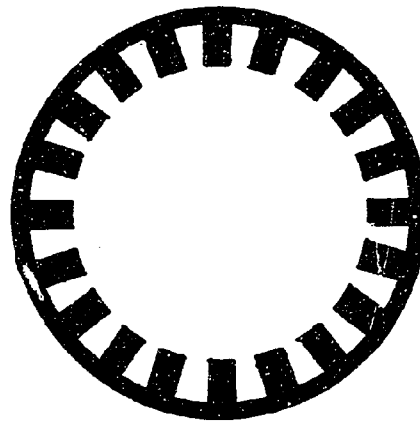

CASE-BONDED NF CHARGE

FIGURE 7. (U) COMPARISON OF LAW CHARGES

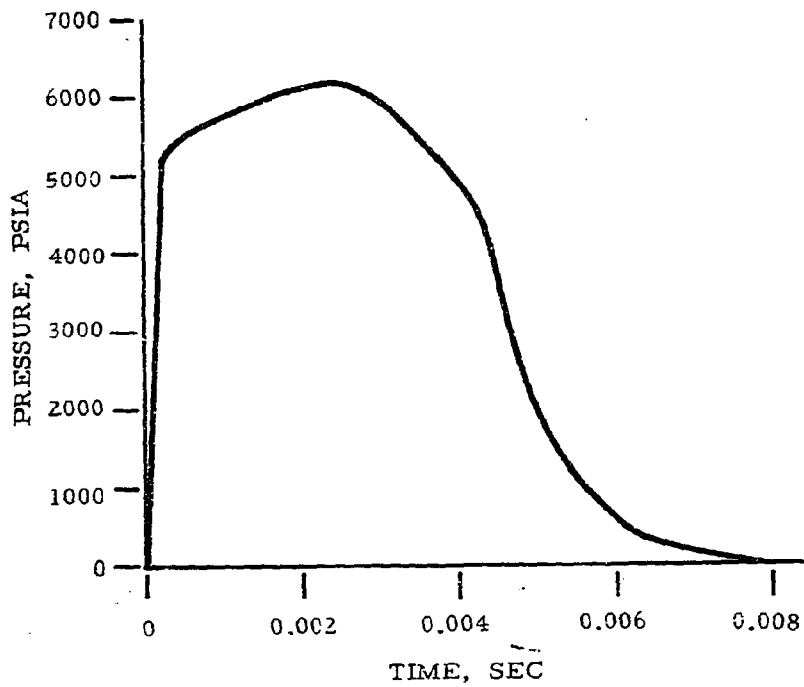

FIGURE 8. (U) PRESSURE TRACE FROM NF LAW MOTOR FIRING

4. (U) Discussion of Problems

The acceptance of case-bonded NF propellants for these applications depends on the resolution of two uncertainties. First, smokelessness is usually desired of all tactical close-support weapons. The NF propellant contained ammonium perchlorate and 1% aluminum, both of which contribute to smoke formation. Eliminating the aluminum would reduce smoke and would not affect performance or combustion stability, since later work has shown that 1% aluminum does not stabilize the propellant. The ammonium perchlorate produces smoke at high humidities. Movies of the tests have indicated that very little smoke would be seen under most conditions, even with aluminum in the system. While M-7 contains some potassium perchlorate and is not a completely smokeless propellant, it is already service-accepted. The importance of smoke from the NF unit at high humidity would require additional evaluation.

Second, reliability and safe operation are of primary concern in shoulder-fired weapons. Motors made from M-7 sticks are inherently fail-safe and have been tested with loose or fragmented grains with no apparent safety hazard. Since the NF unit is a case-bonded system, a potential hazard exists if case-bond failure and/or grain breakup occur. It is doubtful that a practicable case could be designed to withstand the worst conditions (complete case-bond release or complete grain breakup). The reliability of the bond would have to be proved in exhaustive testing, and quality control in production would have to be stringent. However, reliable case-bonding has been maintained in many weapons and should be attainable in this type of motor with this propellant.

CONFIDENTIAL

Section III. (C) SUSTAINERS FOR AIR-DEFENSE MISSILES

1. (C) Description of Redeye Sustainer Motor

(C) Tactical air-defense weapons such as Redeye require moderately-long-burning sustainer motors to be effective at long ranges. This kind of missile is supersonic, and without some propulsive force aerodynamic drag rapidly slows the vehicles below a useful velocity. In the tactical Redeye, the case diameter was small, and a centrally-perforated propellant grain was not practicable. A cartridge-loaded, end-burning grain made from poly(vinyl chloride), dioctyl adipate, ammonium perchlorate, and aluminum was used. Axially-oriented silver wires augmented the burning rate and provided the required thrust level and burning time.⁴ The tactical unit burns at 2000 psia for about 5.5 seconds, producing a thrust of 220 lbf and a total impulse of 1411 lbf-sec. The effective burning rate of the wire-augmented propellant is 3.1 in/sec at the operating pressure. The density of the propellant is 0.065 lbm/in³, and the delivered specific impulse at motor conditions, including the contribution of the liner to the thrust but disregarding the weight of the liner burned, is 241 lbf-sec/lbm.

(U) The burning rates of NF propellants made it possible to meet the Redeye requirements without the use of silver wires, and the specific impulse advantage also promised significant improvements in performance. In another program, techniques were developed to facilitate casting of head-end bonded, end-burning grains directly into the motor case, thereby eliminating the costly hand labor associated with cartridge-loaded grains (7). A short program was set up to combine the NF propellant and the new motor fabrication technique in full-size hardware which duplicated the Redeye configuration.

2. (C) Propellant and Liner Tailoring

(C) RH-SE-103 was chosen for this demonstration because it had been studied more extensively than any other NF propellant (Table VI). The anticipated specific impulse was 265 lbf-sec/lbm at motor conditions, which allowed a reduction in burning rate from the 3.1 in/sec in the tactical unit. With 8 μ ammonium perchlorate, the burning rate of RH-SE-103 was 2.8 in/sec at 2000 psia (Figure 9), which was adequate to duplicate the Redeye thrust. The temperature coefficient of the propellant at 1000 psia was 0.13%/F°.

⁴Unit 341, CPLA/M1 Rocket Motor Manual, II.

CONFIDENTIAL

| Table VI. (C) Formulation of RH-SE-103ai Propellant | | |
|---|----------------------|--------------|
| Ingredient | Function | Wt. % |
| NFPA | Energetic comonomer | 12.48 |
| Acrylic acid | Functional comonomer | 0.52 |
| TVOPA | Plasticizer | 26.00 |
| Ammonium perchlorate (8μ) ^a | Oxidizer | 46.00 |
| Aluminum (3μ) ^b | Fuel | 15.00 |
| Unox-221 | Crosslinker | 2.00 (added) |

^a Coated with 1% Alumina-C; Degussa, Inc., Kearny, N. J.
^b Alcoa 140; Aluminum Company of America, Pittsburgh, Pa.

(U) This application required the use of a flexible restrictor to which the propellant would bond. Silica-filled butyl rubber (SMR 81-11)⁵ with a coating of NL-9 bonding lacquer (Table VII), which had given good bonding results when the surface was washed with acetone (Table VIII), was chosen for Redeye. Especially significant was the fact that bond-test data indicated extensive surface preparation to be unnecessary. Normally, surface roughening by sanding or sandblasting is necessary to obtain good bonds. This sort of surface preparation in a small motor like the Redeye is difficult, and the elimination of this step contributed to the simplicity of motor processing.

| Table VII. (U) Formulation of NL-9 Liner | | |
|--|----------------------|-------|
| Ingredient | Function | Wt. % |
| Methyl acrylate | Comonomer | 9.22 |
| Methyl methacrylate | Comonomer | 9.22 |
| Acrylic acid | Functional comonomer | 3.26 |
| Ethyl acetate | Solvent | 78.30 |

⁵West American Rubber Company, Stoner Rubber Div., Orange, California.

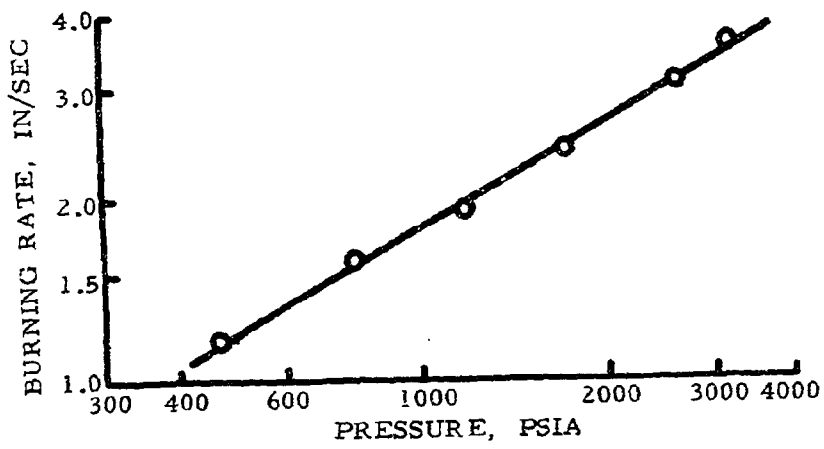

FIGURE 9. (U) BURNING RATE OF RH-SE-193ai

CONFIDENTIAL

| Table VIII. (C) Results of Bond Tests with RH-SE-103ai Propellant With NL-9 Lacquer on Butyl Rubber | | |
|--|------------------------------|--|
| Treatment of Butyl Rubber Surface | Storage Time at 140°F, weeks | Bond Tensile Result ^a (psi) |
| Washed with acetone | 0 | 58 |
| | 2 | 54 |
| | 4 | 57 |
| Sandblasted, washed with acetone | 0 | 56 |
| | 2 | 48 |
| | 4 | 57 |

^aAll breaks occurred in the propellant.

(C) Cases were prepared by (1) insulating with 42-RPD⁶, (2) coating the 42-RPD with a release agent, (3) bag-molding the butyl restrictor in place. At the head end of the motor, stress relief was provided by a PBAA potting compound which filled the elliptical dome. This also provided a flat, silverless surface at burnout. Butyl rubber was bonded to the PBAA, and the entire butyl surface was dip-coated with acrylic lacquer. The grain was cast directly in the case, and the resulting motor configuration is shown in Figure 10.

3. (C) Results of Firings

(U) Nine motors from two batches of propellant were tested at temperatures of -35, 77, and 135°F. In these nine motors there were no aberrations in the pressure- and thrust-time curves; three typical traces are shown in Figure 11. Post-firing inspections indicated that the butyl rubber thickness could be reduced, but that all inert components performed well. The data indicated good reproducibility and high specific impulse (Table IX).

(U) The motors delivered more total impulse than expected, primarily because a large amount of restrictor burned. The restrictor contribution also caused pressure levels to be slightly higher than designed, but minor modifications to the burning rate would correct these problems. The slight ramp rise in pressure which occurred during the first two seconds after ignition was a result of the increasing exposure of the restrictor surface as the grain burned back. After two

⁶Raybestos Manhattan, Manheim, Pa.

CONFIDENTIAL

seconds, the aft end of the restrictor regressed as fast as the grain and the pressure stabilized.

| Table IX: (U) Results of Firings of Cast-in-Case NF Propellant Grains in Redeye Configuration | | | | | | | |
|---|------------------|------------------|-------------------------|--------------------------|-------------|--------------------|-----------|
| A. Pressure Data | | | | | | | |
| Round No. | Test Temp., (°F) | K_n | \bar{P}_b (psia) | \bar{r}_b (in/sec) | t_b (sec) | \bar{P}_a (psia) | Batch No. |
| 7766 | +77 | 67.9 | 2101 | 2.88 | 6.43 | -- | 1128 |
| 7781 | +77 | 69.0 | 2221 | 3.06 | 6.10 | 2202 | 1128 |
| 7782 | +77 | 69.1 | 2214 | 3.03 | 6.25 | 2184 | 1128 |
| 7988 | +77 | 70.0 | 2524 | 3.45 | 5.36 | 2430 | 1145 |
| 8806 | +77 | 69.0 | 2501 | 3.29 | 5.32 | 2411 | 1145 |
| 7783 | +135 | 67.9 | 2542 | 3.54 | 5.35 | 2464 | 1128 |
| 8007 | +135 | 69.0 | 2891 | 3.98 | 4.65 | 2744 | 1145 |
| 7784 | -35 | 67.1 | 1672 | 2.33 | 8.10 | 1653 | 1128 |
| 7987 | -35 | 70.0 | 1903 | 2.59 | 7.22 | 1853 | 1145 |
| B. Thrust Data | | | | | | | |
| Round No. | Test Temp., (°F) | Propellant (lbm) | Total Impulse (lbf-sec) | I_{sp}^a (lbf-sec/lbm) | F_a (lbf) | | |
| 7766 | +77 | 6.55 | -- | -- | -- | | |
| 7781 | +77 | 6.20 | 1670 | 269.4 | 261 | | |
| 7782 | +77 | 6.19 | 1680 | 271.4 | 258 | | |
| 7988 | +77 | 6.05 | 1674 | 276.8 | 288 | | |
| 8006 | +77 | 5.90 | 1614 | 273.5 | 284 | | |
| 7783 | +135 | 6.08 | 1686 | 277.3 | 294 | | |
| 8007 | +135 | 5.99 | 1675 | 279.6 | 332 | | |
| 7784 | -35 | 6.17 | 1608 | 260.6 | 190 | | |
| 7987 | -35 | 6.04 | 1571 | 260.0 | 209 | | |
| ^a All delivered specific impulse values were corrected to an expansion ratio of 15 (same as tactical Redeye). The liner contribution to the total impulse is acknowledged, but the liner mass burned was disregarded in obtaining the specific impulse values. | | | | | | | |

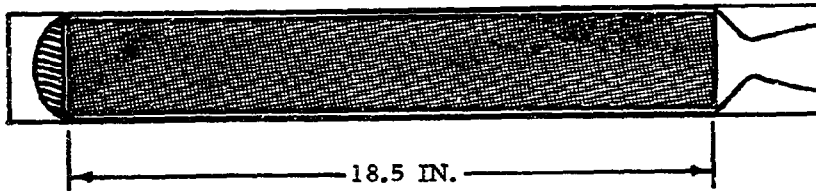

FIGURE 10. (U) CAST-IN-CASE CHARGE FOR REDEYE SUSTAINER
MOTOR USING HIGH-RATE NF PROPELLANT

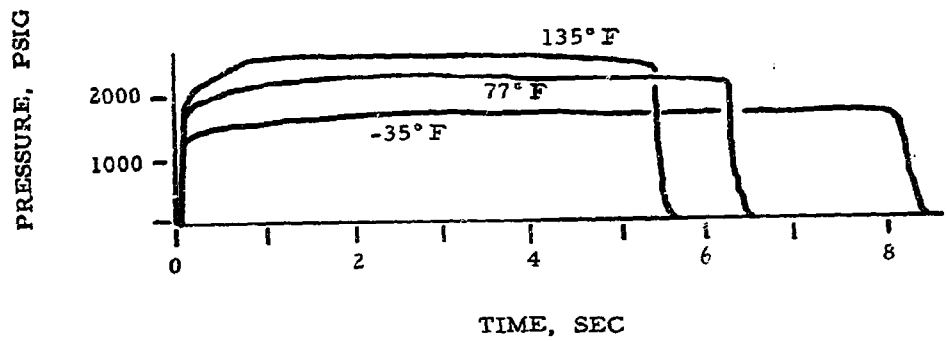

FIGURE 11. (U) PERFORMANCE OF NF REDEYE SUSTAINER MOTORS

CONFIDENTIAL

(C) The performance of these motors compared favorably with that of the tactical Redeye. The total impulse of the unit was increased by about 19% (Table X). The additional energy could be used to extend the burning time while maintaining the same thrust level (as was attempted in this work); this should improve the performance of the Redeye missile against high-speed targets at long ranges. The use of NF propellant could also give manufacturing economies by eliminating the need for hand-strung wires and reducing labor costs per round.

| | Tactical: PVC Composite Propellant | Prototype: NF Propellant |
|--|--|-----------------------------|
| Propellant mass, lbm | 5.8 | 6.2 |
| Average pressure, psia | 2000 | 2214 |
| Burning time, sec | 5.6 | 6.2 |
| Propellant burning rate, in/sec | 3.2 | 3.0 |
| Average thrust, lbf | 252 | 258 |
| Total impulse, lbf-sec | 1411 | 1680 |
| Specific impulse, ^a lbf-sec/lbm | 241 | 271 |

^a Both specific impulse values are based on loaded propellant mass.

Section IV. (C) CONCLUSIONS

NF propellants have been tailored to meet the requirements of three different tactical rocket motors—the TOW launch motor, the LAW motor, and the Redeye sustainer motor. Successful experimental firings in each configuration demonstrated the advantage of NF propellants.

Firings in a TOW launch motor showed that the propellant had low temperature sensitivity, even at high pressures, and that the action time of 0.052 seconds at low temperature was possible with a case-bonded slotted-tube grain. The NF launch motor met all original specifications, while the tactical M-7 motor is low on total impulse and its action time exceeds 0.052 seconds at -25°F .

A case-bonded NF propellant grain was cast in a tactical aluminum LAW case, and the performance of the M-7 charge was duplicated in a static firing. Higher burning rates (which are now in hand) would simplify the grain configuration.

The use of NF propellant in the Redeye sustainer resulted in a 19% gain in total impulse. In these tests, the thrust level was kept nearly equal to that of the tactical motor, and the burning time increased by about 0.6 seconds. An increased burning time would increase the effective range of the missiles. At the same time, the high burning rate of the propellant allowed the use of simpler manufacturing techniques and eliminated the need for axial silver wires; this would reduce the cost of the unit in spite of the higher cost of raw materials.

These results should not be construed as a recommendation for the use of NF propellants in the motor configurations used; however, they clearly demonstrated that NF propellants should be useful in a wide variety of future missile systems.

PRECEDING PAGE BLANK - NOT FILMED.

(U) REFERENCES

1. Rohm and Haas Co., Huntsville, Alabama, BALLISTIC CHARACTERISTICS OF NF PROPELLANTS(U), S. E. Anderson and B. L. Thompson, 5 Oct. 1965, Report S-85, U. S. Army Missile Command, Redstone Arsenal, Alabama 35809, Contracts DA-01-021 AMC-11536(Z) and DA-01-021 AMC-11608(Z), (Confidential), AD-366 080.
2. Rohm and Haas Co., Huntsville, Alabama, BALLISTIC SCALE-UP OF NF PROPELLANTS I. 80-LBM MOTOR DEMONSTRATION FIRING(U), S. E. Anderson, 17 March 1966, Report S-94, U. S. Army Missile Command, Redstone Arsenal, Alabama 35809, Contracts DA-01-021 AMC-11536(Z) and DA-01-021 AMC-11608(Z), (Confidential), AD-370 635.
3. Rohm and Haas Co., Huntsville, Alabama, BALLISTIC SCALE-UP OF NF PROPELLANTS IN A 6-INCH MOTOR (INTERIM REPORT)(U), S. E. Anderson, 21 April 1967, Report S-125, U. S. Army Missile Command, Redstone Arsenal, Alabama 35809, Contract DA-01-021 AMC-13864(Z), (Confidential), AD-380 551.
4. Rohm and Haas Co., Huntsville, Alabama, BALLISTIC SCALE-UP OF NF PROPELLANTS III. LINER DEVELOPMENT(U), S. E. Anderson and B. L. Thompson, July 1967, Report S-142, U. S. Army Missile Command, Redstone Arsenal, Alabama 35809, Contracts DA-01-021 AMC-13864(Z) and DAAH01-67-C-0947 (Confidential), AD-817 647.
5. Rohm and Haas Co., Huntsville, Alabama, BALLISTIC SCALE-UP OF NF PROPELLANTS IV. EVALUATION OF NF PROPELLANTS IN A 6-INCH MOTOR (FINAL REPORT)(U), S. E. Anderson, August 1967, Report S-144, U. S. Army Missile Command, Redstone Arsenal, Alabama 35809, Contract DA-01-021 AMC-13864(Z) and DAAH01-67-C-0947, (Confidential), AD-383 521.
6. Rohm and Haas Co., Huntsville, Alabama, APPLICATION OF NF PROPELLANTS--A STUDY REPORT(U), S. E. Anderson, 25 May 1965, Report S-62, U. S. Army Missile Command, Redstone Arsenal, Alabama 35809, Contracts DA-01-021 AMC-11536(Z), and DA-01-021 AMC-11608(Z), (Confidential), AD-360 789.

7. Rohm and Haas Co., Huntsville, Alabama, DEVELOPMENT OF CAST-IN-CASE END-BURNING CHARGES I, RELEASED-LINER TECHNIQUE (U), S. E. Anderson and B. L. Thompson, 9 Dec. 1966, Report S-123, U. S. Army Missile Command, Redstone Arsenal, Alabama 35809, Contract DA-01-021 AMC-13864(Z), (Confidential), AD-377 532.
8. Rohm and Haas Co., Huntsville, Alabama, BURNING RATES OF SOLID COMPOSITE PROPELLANTS AT PRESSURES UP TO 10,000 psig (U), R. B. Cole, 15 Sept., 1966, Report S-80, U. S. Army Missile Command, Redstone Arsenal, Alabama 35809, Contract DA-01-021 ORD-11909(Z), (Confidential), AD-375 686.
9. Rohm and Haas Co., Huntsville, Alabama, DEMONSTRATION OF THE USE OF COMPOSITE PLASTISOL-NITROCELLULOSE PROPELLANT IN A SHORT-BURNING ROCKET (U), S. E. Anderson, 13 January 1965, Report S-55, U. S. Army Missile Command, Redstone Arsenal, Alabama 35809, Contract DA-01-021 AMC-10037(Z), (Confidential), AD-356 309.
10. Rohm and Haas Co., Huntsville, Alabama, EVALUATION OF OPE, A NEW NF PROPELLANT INGREDIENT (U), S. E. Anderson, M. G. Bladwin, T. H. Pratt, and R. D. Shoults, 7 Dec. 1965, Report S-92, U. S. Army Missile Command, Redstone Arsenal, Alabama 35809, Contract DA-01-021 AMC-11536(Z), (Confidential), AD-367 703.

CONFIDENTIAL

(C) GLOSSARY

Acronyms

| | |
|-------|--|
| AP | ammonium perchlorate |
| NFPA | 2,3-bis(difluoramino)propyl acrylate |
| PBAA | polybutadiene-acrylic acid copolymer |
| TVOPA | 1,2,3-tris [1,2-bis(difluoramino)ethoxy] propane |

Symbols

| | |
|-------------|---|
| D_m^{50} | weight-mean-average particle diameter |
| K_n | burning surface to throat area ratio |
| \bar{P}_a | action time average chamber pressure, psia |
| \bar{P}_b | burning time average chamber pressure, psia |
| \bar{r}_b | average linear burning rate of propellant, in/sec |
| t_a | action time (pressure), psia |
| t_b | burning time (pressure), psia |
| I_{spd} | delivered propellant specific impulse, lbf-sec/lbm |
| I_{sps} | standard deliverable propellant specific impulse, lbf-sec/lbm |
| I_{sps}^o | standard theoretical propellant specific impulse, lbf-sec/lbm |
| ϵ | nozzle area expansion ratio |

CONFIDENTIAL

| DOCUMENT CONTROL DATA - R & D | | |
|--|---|---|
| <i>(Security classification of title, body of abstract and indexing annotation must be entered when the overall report is classified)</i> | | |
| 1. ORIGINATING ACTIVITY (Corporate author) Rohm and Haas Company Redstone Research Laboratories Huntsville, Alabama 35807 | | 2A. REPORT SECURITY CLASSIFICATION Confidential |
| | | 2B. GROUP 4 |
| 3. REPORT TITLE Ballistic Scale-Up of NF Propellants V. Demonstration Firings in Tactical Configurations (U) | | |
| 4. DESCRIPTIVE NOTES (Type of report and inclusive dates) | | |
| 5. AUTHOR(S) (First name, middle initial, last name) Stanley E. Anderson | | |
| 6. REPORT DATE October 1967 | 7A. TOTAL NO. OF PAGES 29 | 7B. NO. OF REFS 10 |
| 8A. CONTRACT OR GRANT NO. DA-01-021 AMC-13864(Z) and DAAH01-67-C-0947 A. PROJECT NO. | 9A. ORIGINATOR'S REPORT NUMBER(S) Technical Report S-149 | |
| 9. OTHER REPORT NUM (Any other numbers that may be assigned this report) | | |
| 10. DISTRIBUTION STATEMENT Initial distribution of this report has been made in accordance with contractual agreements. Qualified users may obtain copies from Defense Documentation Center | | |
| 11. SUPPLEMENTARY NOTES | | 12. SPONSORING MILITARY ACTIVITY Research and Development Directorate U. S. Army Missile Command Redstone Arsenal, Alabama 35809 |
| 13. ABSTRACT (C) ABSTRACT <p>(U) The adaptability of high-energy NF propellants was demonstrated in three short-term development programs. The TOW launch motor, the LAW motor, and the Redeye sustainer motor were used as examples of current systems to show the utility of the unique properties of NF propellants. These properties (i. e., high burning rate, high specific impulse, good high-pressure ballistics) will be useful in designing future systems.</p> <p>(C) Using NF propellant, a case-bonded, slotted-tube grain in the TOW launch-motor configuration met all original specifications. The action time at -25° F was 0.043 seconds (0.009 seconds shorter than specified) and the total impulse was 290 lbf-sec (3½% over the target). Propellant performance was slightly better than predicted; burning rate was 8.4 in/sec at 8266 psia, and specific impulse was 245 lbf-sec/lbm at motor conditions. The variation in motor operating pressure with temperature was half that of the tactical unit with M-7 propellant. It was concluded that NF propellants will have real utility in short-burning-time motors.</p> <p>(Abstract continued)</p> | | |

DD FORM 1473

REPLACES DD FORM 1473, 7 JAN 64, WHICH IS OBSOLETE FOR ARMY USE.

CONFIDENTIAL

CONFIDENTIAL

| T4. | KEY WORDS | LINK A | | LINK B | | LINK C | |
|-----|-----------|--------|----|--------|----|--------|----|
| | | ROLE | WT | ROLE | WT | ROLE | WT |
| | | | | | | | |

(Abstract continued)

(C) In another demonstration of the good high-pressure ballistics of NF propellant, a case-bonded wagonwheel grain which was cast in an aluminum LAW case duplicated the performance of the tactical motor at 77° F in almost every respect. The specific impulse delivered by the NF propellant was 265 lbf-sec/lbm, compared with 241 for the M-7 in the tactical LAW. Thrust action time was 0.007 seconds.

(C) The Redeye demonstration motors were made using a new technique for casting end-burning grains directly in a motor case. Acrylic copolymer lacquers on butyl rubber restrictor provided excellent bonding for the propellant. NF propellants had burning rates which eliminated the need for augmentation by wires, such as is done in the operational version. The NF motors gave a 19% increase in total impulse while maintaining about the same thrust and pressure levels.

(U) The improved performance and new manufacturing techniques make this propellant system attractive for use in future air-defense systems.

CONFIDENTIAL