

UNCLASSIFIED

AD NUMBER

AD385931

CLASSIFICATION CHANGES

TO: unclassified

FROM: confidential

LIMITATION CHANGES

TO:
Approved for public release, distribution unlimited

FROM:
Distribution: Further dissemination only as directed by Director, Naval Research Laboratory, Washington, DC 20390, OCT 1967, or higher DoD authority.

AUTHORITY

NRL Code/5309 memo dtd 20 Feb 1997; NRL Code/5309 memo dtd 20 Feb 1997

THIS PAGE IS UNCLASSIFIED

UNCLASSIFIED

AD NUMBER
AD385931
CLASSIFICATION CHANGES
TO
confidential
FROM
secret
AUTHORITY
31 Oct 1979, per document marking, DoDD 5200.10

THIS PAGE IS UNCLASSIFIED

AD- 385931

SECURITY REMARKING REQUIREMENTS

DDO 5200.1-R, DEC 78

REVIEW ON 31 OCT 87

SECURITY

MARKING

The classified or limited status of this report applies to each page, unless otherwise marked.

Separate page printouts MUST be marked accordingly.

THIS DOCUMENT CONTAINS INFORMATION AFFECTING THE NATIONAL DEFENSE OF THE UNITED STATES WITHIN THE MEANING OF THE ESPIONAGE LAWS, TITLE 18, U.S.C., SECTIONS 793 AND 794. THE TRANSMISSION OR THE REVELATION OF ITS CONTENTS IN ANY MANNER TO AN UNAUTHORIZED PERSON IS PROHIBITED BY LAW.

NOTICE: When government or other drawings, specifications or other data are used for any purpose other than in connection with a definitely related government procurement operation, the U. S. Government thereby incurs no responsibility, nor any obligation whatsoever; and the fact that the Government may have formulated, furnished, or in any way supplied the said drawings, specifications, or other data is not to be regarded by implication or otherwise as in any manner licensing the holder or any other person or corporation, or conveying any rights or permission to manufacture, use or sell any patented invention that may in any way be related thereto.

L

SECRET

NRL Memorandum Report 1811
Copy No. ~~1~~ of 165 Copies

AD385931

Some Skywave Radar Constraints
[Unclassified Title]

J. L. AHEARN, W. C. HEADRICK, J. M. HEADRICK, AND E. W. WARD

Radar Division

October 1967



DDC
RECORDED
DEC 21 1967
REGULATED
D

NAVAL RESEARCH LABORATORY
Washington, D.C.

DDC CONTROL
NO. 75105

SECRET

Downgraded at 12-year intervals;
Not automatically declassified.

SEE INSIDE OF FRONT COVER FOR DISTRIBUTION RESTRICTIONS

SECRET

SECURITY

This document contains information affecting the national defense of the United States within the meaning of the Espionage Laws, Title 18, U.S.C., Sections 793 and 794. The transmission or revelation of its contents in any manner to an unauthorized person is prohibited by law.

In addition to security requirements which apply to this document and must be met, it may be further distributed by the holder *only* with specific prior approval of Director, Naval Research Laboratory, Washington, D.C. 20390.

SECRET

SECRET

CONTENTS

Abstract	ii
Problem Status	ii
Authorization	ii
INTRODUCTION	1
NOISE AND INTERFERENCE	1
Equipment Description	1
Data Acquisition	2
Data Presentation and Comment	2
Occupancy and/or Noise Relating to HF Radar	3
SIGNAL ANALYSIS EXAMPLES	25
SLOW SPEED TARGET TEST AND CLUTTER CHARACTERISTICS	40
DISCUSSION	53
REFERENCES	54

"This document contains information affecting the National Defense of the United States within the meaning of the Espionage Laws, Title 18, U. S. C., Section 793 and 794. Its transmission or the revelation of its contents in any manner to an unauthorized person is prohibited by law."

STATEMENT #5 CLASSIFIED

In addition to security requirements which apply to this document and must be met, it may be further distributed by the holder only with specific approval of "DIR. NRL WASH. DC. 20390"

SECRET

DDC CONTROL
NO. 75165

SECRET

ABSTRACT
(Secret)

Sky wave radar performance and method of operation are limited by other users of the hf band and by variability of the propagation medium. Examples of measured noise and interference background show features of this constraint; indications are that any pulse system must work against an interference background greater than that due atmospheric or galactic noise and that the wider the bandwidth the higher the interference level. Signal processing time and target speed discrimination possibilities are studied by frequency analysis of earth backscatter, aircraft echoes, and one way transmissions; effective processing times can be in excess of 10 seconds and tests suggest that part of the time targets with relative speeds as low as 10 knots may be detectable using large dynamic range MTI methods.

Problem Status

This is an interim report on three phases of the problem; work is continuing on these and other phases.

Authorization

USAF MIPR F30602-67-C-0070 Project 673A
USAF MIPR F30602-67-C-0069 Project 673A
ARPA Order No. 160 Amendment 6 Feb. 3, 1965
NRL Problem 53R02-23F,G

SECRET

SECRET

SOME SKYWAVE RADAR CONSTRAINTS
(Unclassified Title)

INTRODUCTION

An HF ionospheric radar has a few environmental conditions to contend with that are peculiarly its own, such as many other users of the band, irregularities of the propagation medium and an omnipresent earth echo. The aim of this report is to give examples and a discussion of some of the conditions that force constraints upon method of operation and signal processing technique. The first section will deal with spectrum occupancy; for many types of radar operation other users set an interference threshold that limits performance capability. In the second section examples of signal frequency analysis will be given for a one way point to point path, an aircraft target, and the earth echo; these examples will demonstrate some of the characteristics of the propagation path and indicate signal processing possibilities. In the third section a particular test and some of its results will be described; this test was specifically aimed at showing the slow speed limits of doppler processing in an earth echo environment. Another test shows backscatter spectral data taken during the sunrise period. The results show how the spectrum changes in width and position relative to zero doppler. (See References at end of report)

PART I. NOISE AND INTERFERENCE

A. Equipment Description

The receiver used is part of the Master Frequency Selector and Programmer equipment funded by ARPA, located at NRL's Chesapeake Bay Division. It covers 4 to 40 Mc in one-Mc bands that are selected by switching the appropriate one-Mc bandpass filter to the input and supplying the correct local oscillator frequency to the mixer. The mixer is followed by a low noise figure IF preamplifier, a variable attenuator, and an IF postamplifier. The IF postamplifier drives a bank of two hundred 5-kc contiguous crystal filters with the crossovers at the 3 dB points. Each crystal filter is followed by an amplifier, detector, and threshold circuit. The threshold circuits operate an array of 200 lights such that the light corresponding to a given 5-kc channel is turned on when a preset threshold is exceeded. RC filtering is used after detection with a range of time constants available from 10 seconds to 1/60 of a second. The RC filter output can be sampled, commutated, and displayed on an oscilloscope giving an amplitude versus frequency display for a 1-Mc band.

Receiver characteristics are:

10 dB noise figure

100 db linear range (front end through crystal filters)

SECRET

SECRET

Channel threshold within ± 1.5 dB

3 to 60 dB shape factor of 3.5

60 dB < image rejection

Figure I-1 is a block diagram of the receiver.

The antennas used were a broadside array, a rotatable antenna, a Collins 237A-1 log periodic, and a vertical firing log periodic. The broadside array has a beamwidth of 15 degrees at 13.5 Mc and 9 degrees at 27 Mc. The rotatable antenna beamwidth is 52 degrees at 10 Mc and 27 degrees at 27 Mc. The Collins 237A-1 beamwidth is approximately 65 degrees. The vertical firing log periodic has a beamwidth of about 70 degrees.

B. Data Acquisition

This data is taken in two ways. The first method consists of photographing the commutated receiver output of a selected 1-Mc band and using a prepared calibration scale to show which 5-kc channels exceeded a given level. Figure I-2 is an example of the data in this form. Little data were taken this way because of the nonuniformity of the amplifiers after the crystal filters. While all amplifiers were adjusted to threshold within ± 1.5 dB at 1 μ V, higher level signals did not track as well as desired. The second method used avoids this disadvantage by setting the variable attenuator, which is in the linear portion of the receiver, for the desired threshold and then photographing the light display. In this manner all channels exceeding the preset threshold for a 1-Mc band are recorded with an accuracy of ± 1.5 dB. Counts from the photographed light displays were then plotted in the form of occupancy graphs as shown in Fig. I-3 & 4. In some cases the photographs of each 1-Mc band were mounted in sequence to show occupancy over a greater frequency span as in Fig. I-5 & 6.

C. Data Presentation and Comment

The occupancy graphs in Fig. I-7 are for 0315 EST and in Fig. I-8 are for 0815 EST. They are included to show how occupancy can change with time. Although some 120 graphs were made like the four shown in Fig. I-3, they are not given in this report, but some plots made from them are given.

In Fig. I-9 the percentage of 5-kc channels available is plotted versus threshold for four azimuths, then all azimuths are averaged. Figure I-10 is a 24-hour average of the number of 5-kc channels available in the 10-11 Mc band. Bands were chosen where a -127 dBW threshold gave between 0 and 10% available channels for Fig. I-11. In Fig. I-12 the 1-Mc bands were chosen where a -127 dBW level gave between 10 and 20% available channels.

SECRET

SECRET

Reference to Figs. I-5 & 6 shows how the frequency corresponding to a given light may be read from Fig. I-13 through Fig. I-20. The records shown in Figs. I-13 & 14 were made at essentially the same time but at an azimuth difference of 20 degrees. Although differences can be found, the two are very similar. More azimuth comparisons are shown in Figs. I-15 & 16. Figures I-17 & 18 were made at azimuths differing by 180 degrees as were Figs. I-19 & 20 which were made some two hours later. The azimuthal difference is not great however the change with time is striking.

Type of service for a given frequency band shows up throughout the data. Places in the spectrum where usage, power, or both are at a comparatively low level are discernible such as 8195 - 8815 kc (maritime mobile), 8815 - 9040 kc (aeronautical mobile), 10005 - 10100 kc (aeronautical mobile), 14000 - 14350 kc (amateur), 16460 - 17360 kc (maritime mobile).

The occupancy as has been measured and exhibited cannot be universally used as a noise model. There has been a continuing effort to measure the noise that controls performance by determining the minimum detectable signal for an operating radar. Results from this investigation are shown in Fig. I-21 as a crosshatched area. Since the NRL radar may suffer a noise disadvantage due to insufficient flexibility it was decided to use the ITSA "rural" noise tabulation in OTH radar performance predictions. This noise appears with its upper and lower deciles in Fig. I-21.

D. Occupancy and/or Noise Relating to HF Radar

Occupancy data shows that a narrowband pulse radar for searching from 500 to 2000 nmi in range must work against a noise or interference level higher than atmospheric or galactic noise. To use CCIR noise data for radar design would require a CW radar operating in Standard Frequency Transmission assignments with a signal bandwidth of 200 c/s. (This is how the data were taken). If one thinks in terms of a radar that covers ranges of 500 to 2000 nmi for 24 hours a day, a frequency span of 5 or 6 Mc to 30 or 40 Mc is implied. A system using bandwidths of 50 to 100 kc will suffer loss of sensitivity that might make it useless for certain classes of targets especially at the shorter ranges and during the nighttime depressed MUF period when HF users are more crowded together. In fact finding 5-kc slots to provide required sensitivity and coverage presents a problem.

SECRET

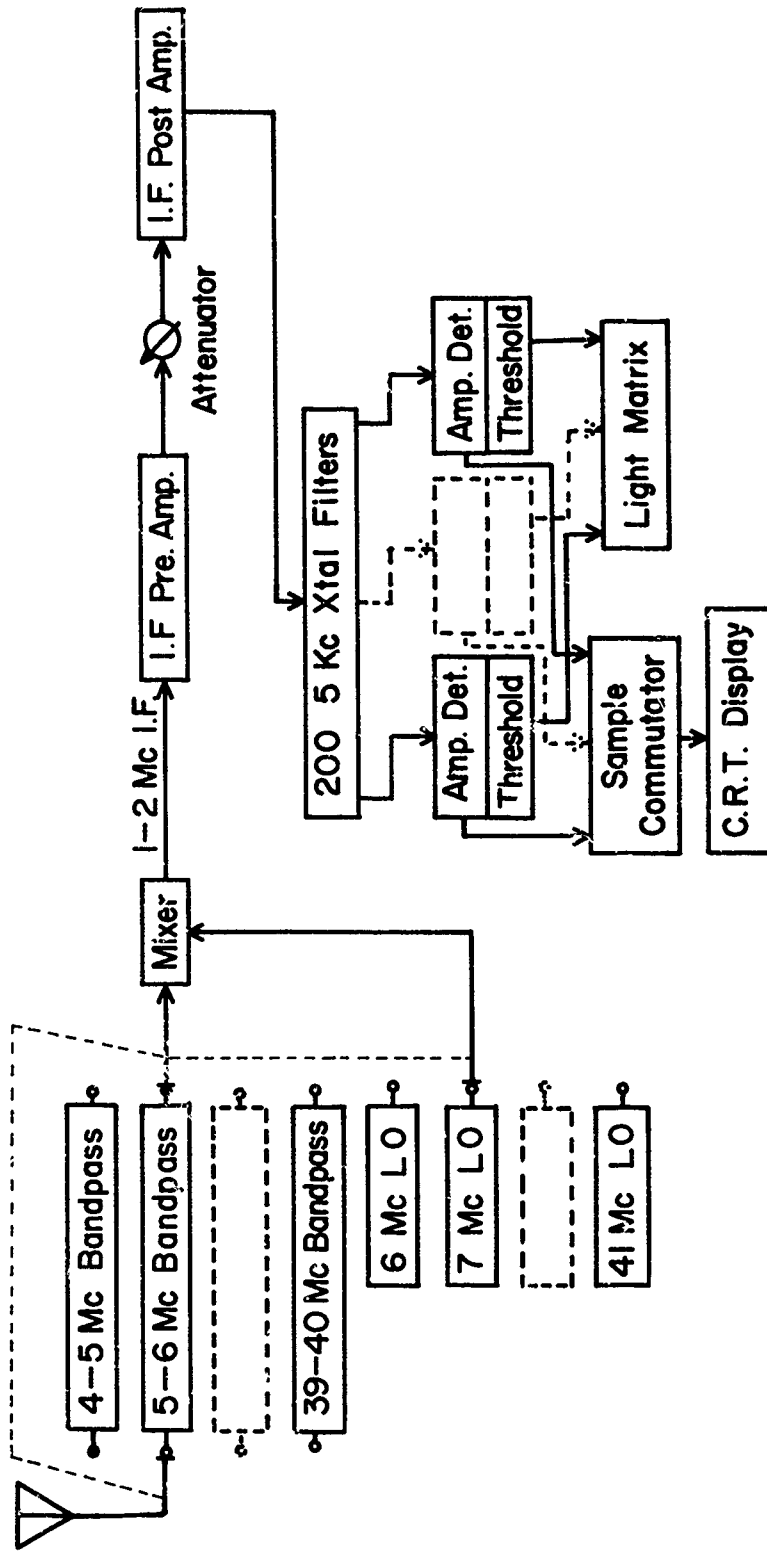

Fig. I-1 - Receiver block diagram

1435R 1/7/66. LP Ant. 180° Az. IF BW 5Kc. Video BW 0.1 cps

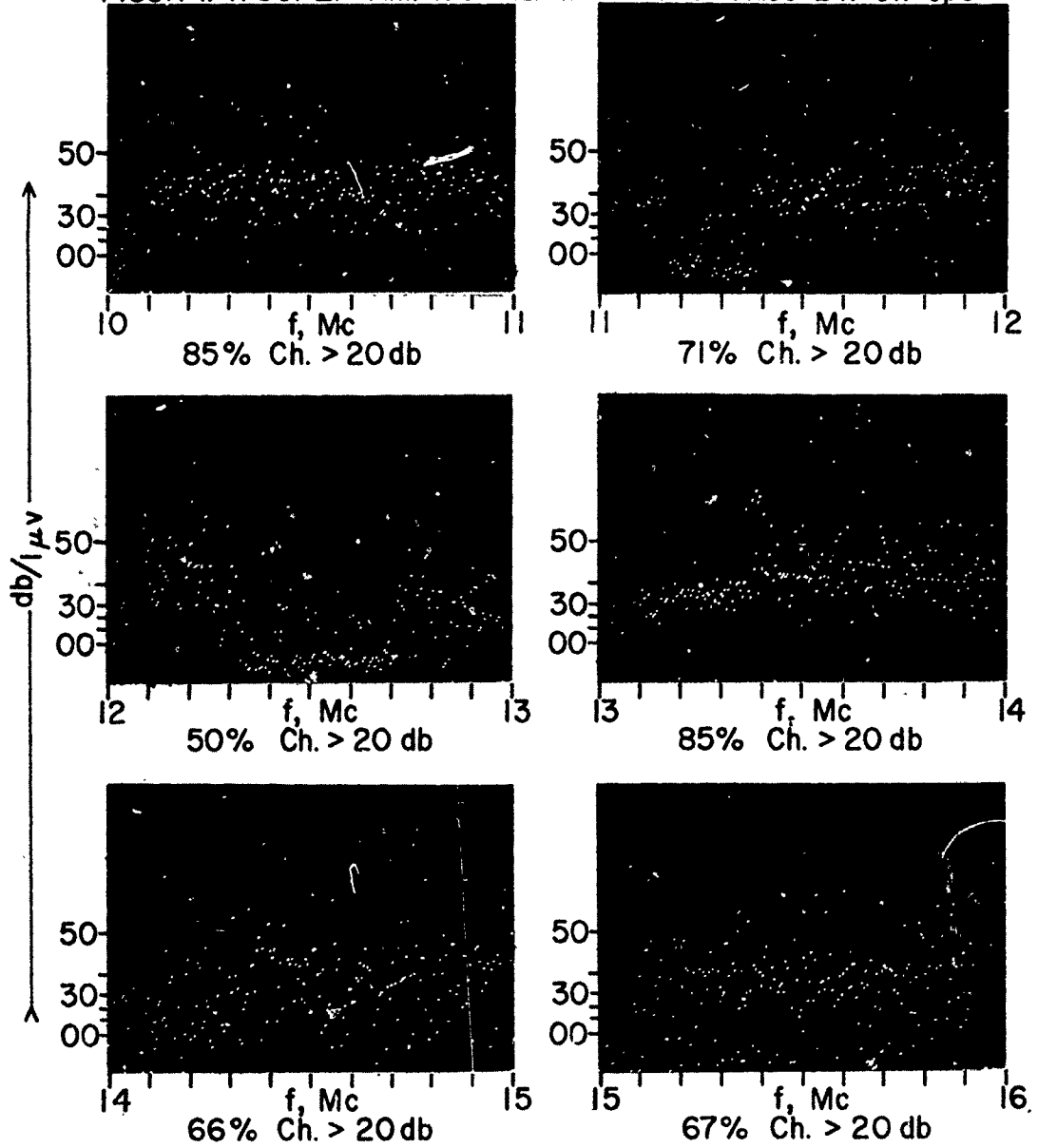

Fig. I-2 - Sampled and commutated output display

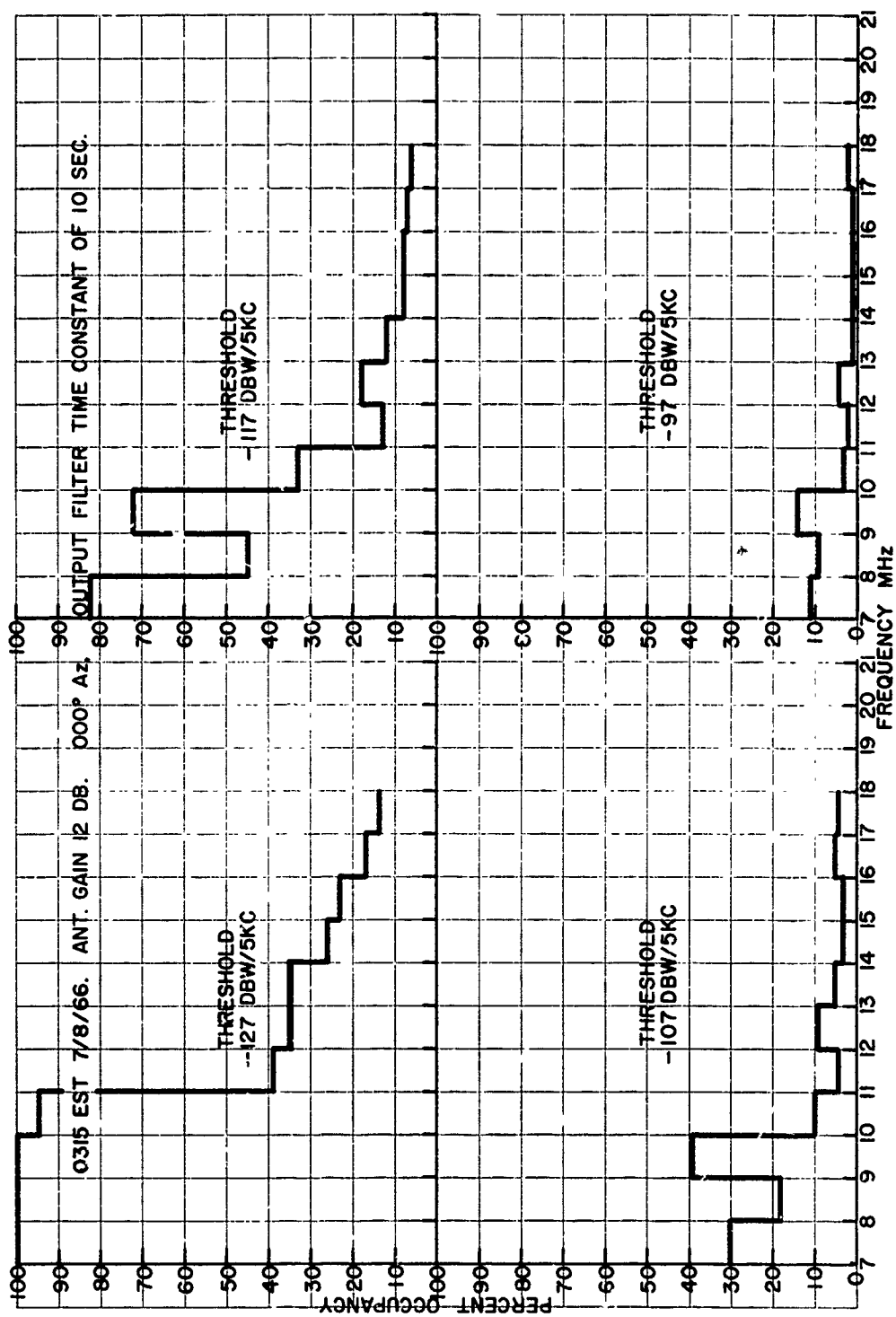

Fig. I-3 - Occupancy vs frequency, 0315 EST 7/8/66

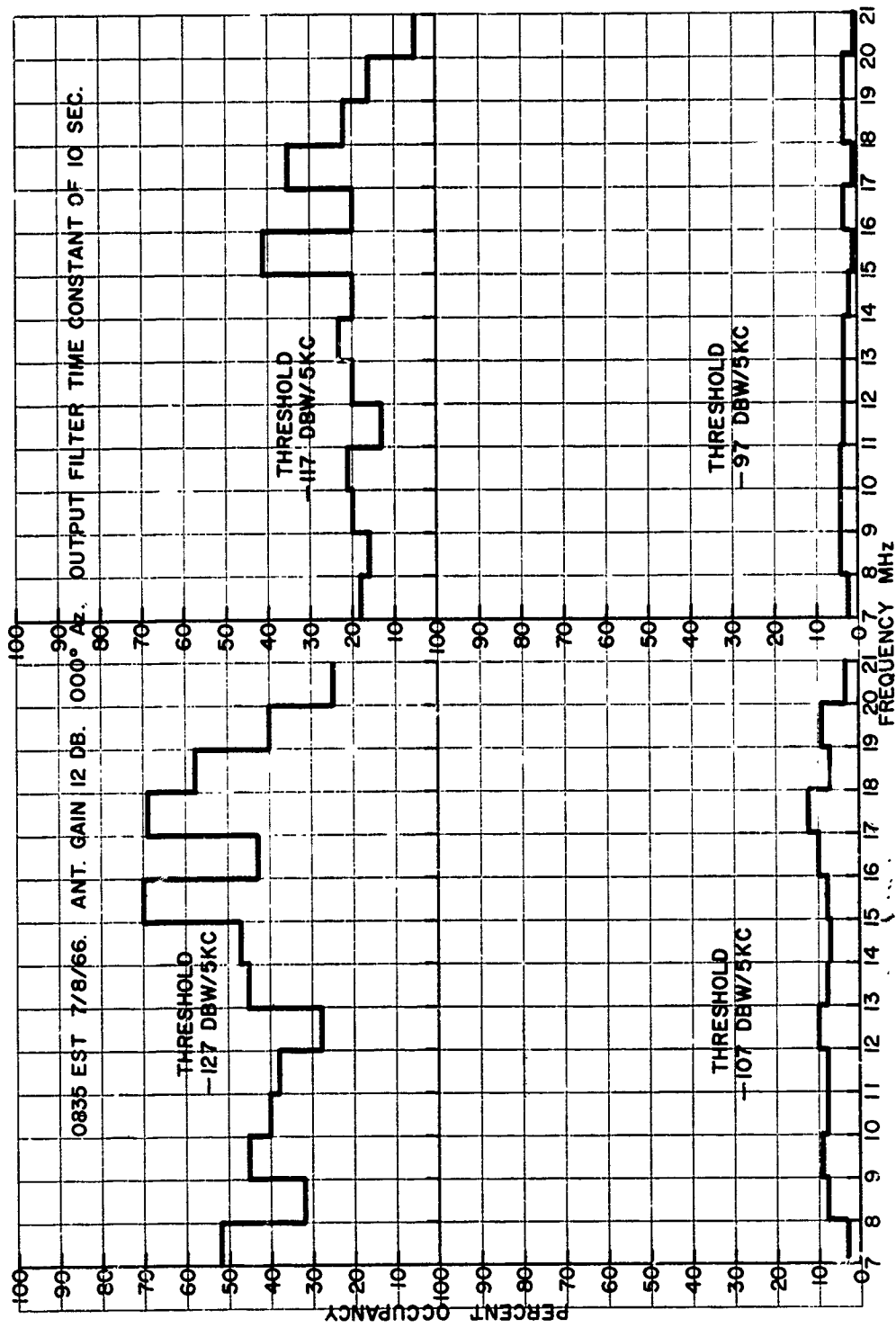

Fig. I-4 - Occupancy vs frequency, 0835 EST 7/8/66

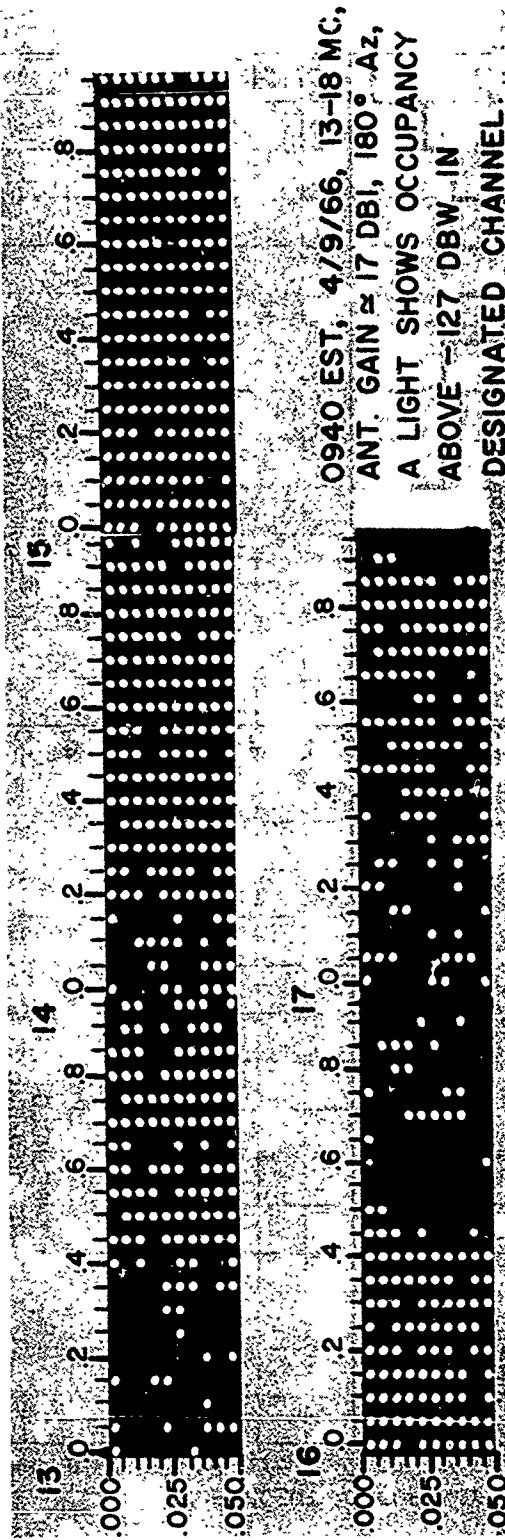

Fig. I-5 - Channel occupancy at -127 dBW/5-kc level

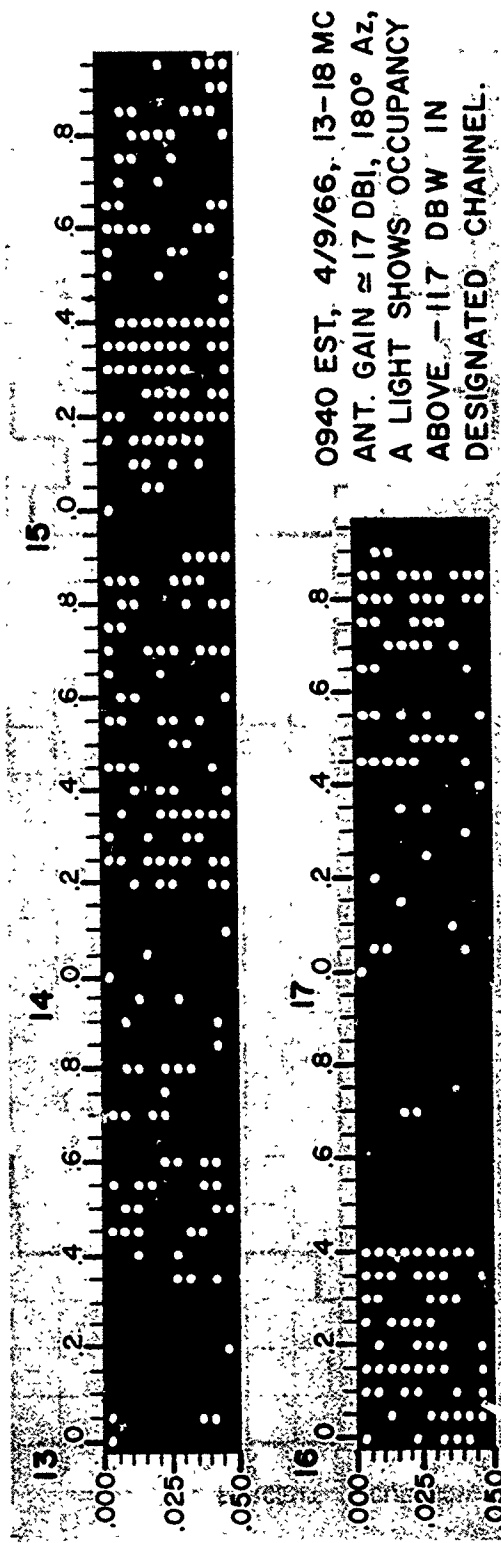

Fig. I-6 - Channel occupancy at -117 dBW/5-kc level

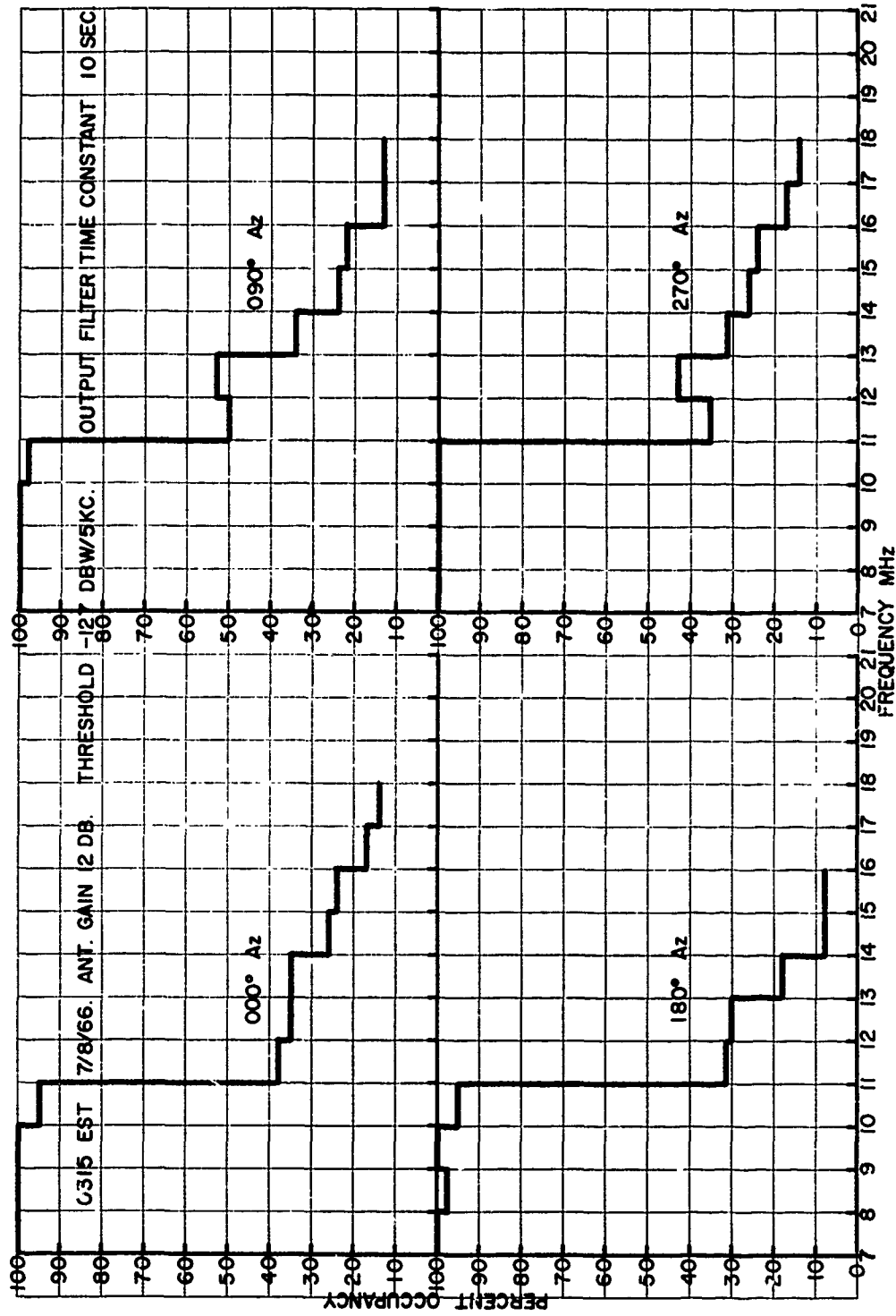

Fig. I-7 - Percentage of 5-kc channels available vs threshold

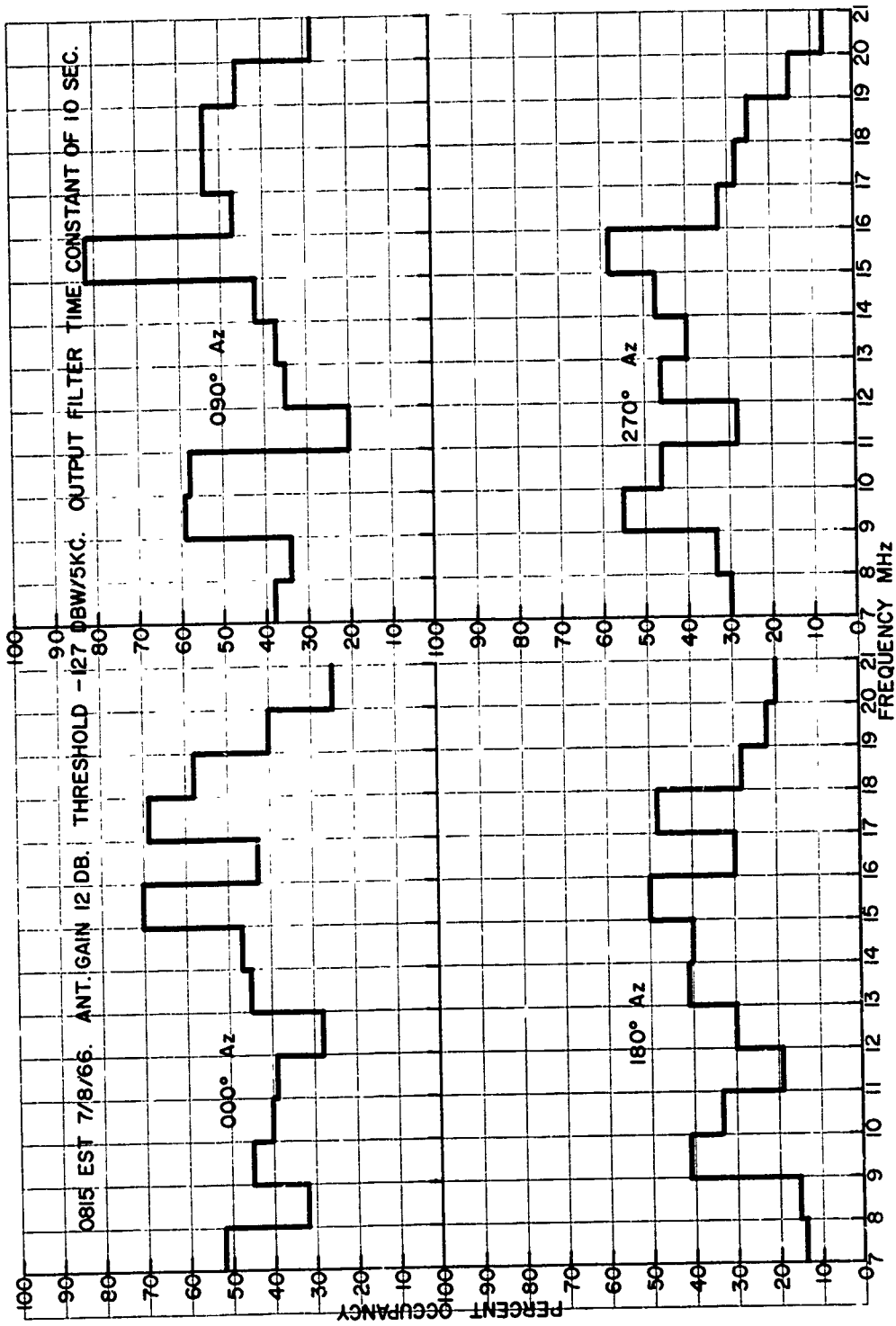

Fig. I-8 - Percentage of 5-kc channels available vs threshold

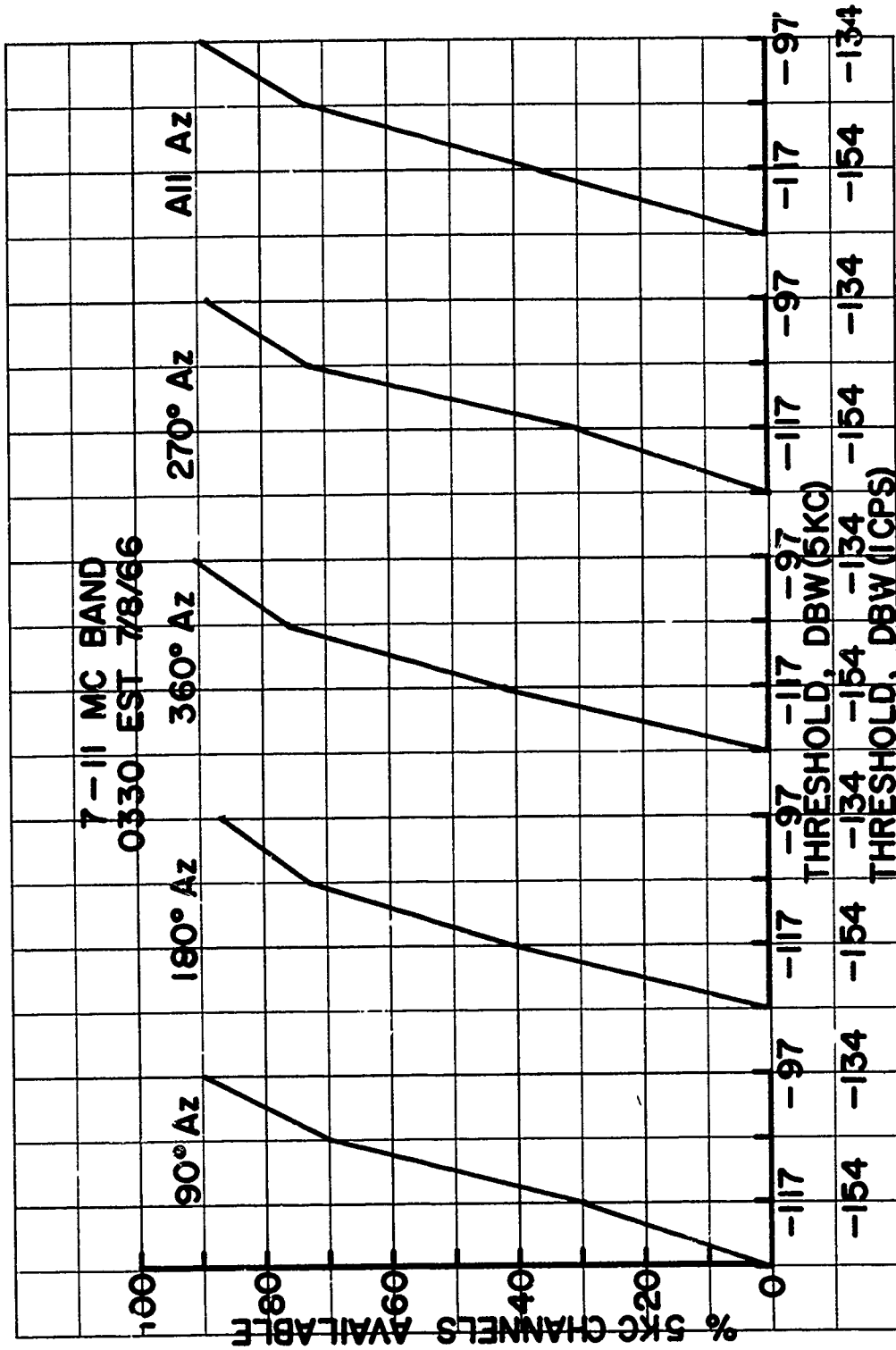

Fig. I-9 - Percentage of 5-kc channels available vs threshold level

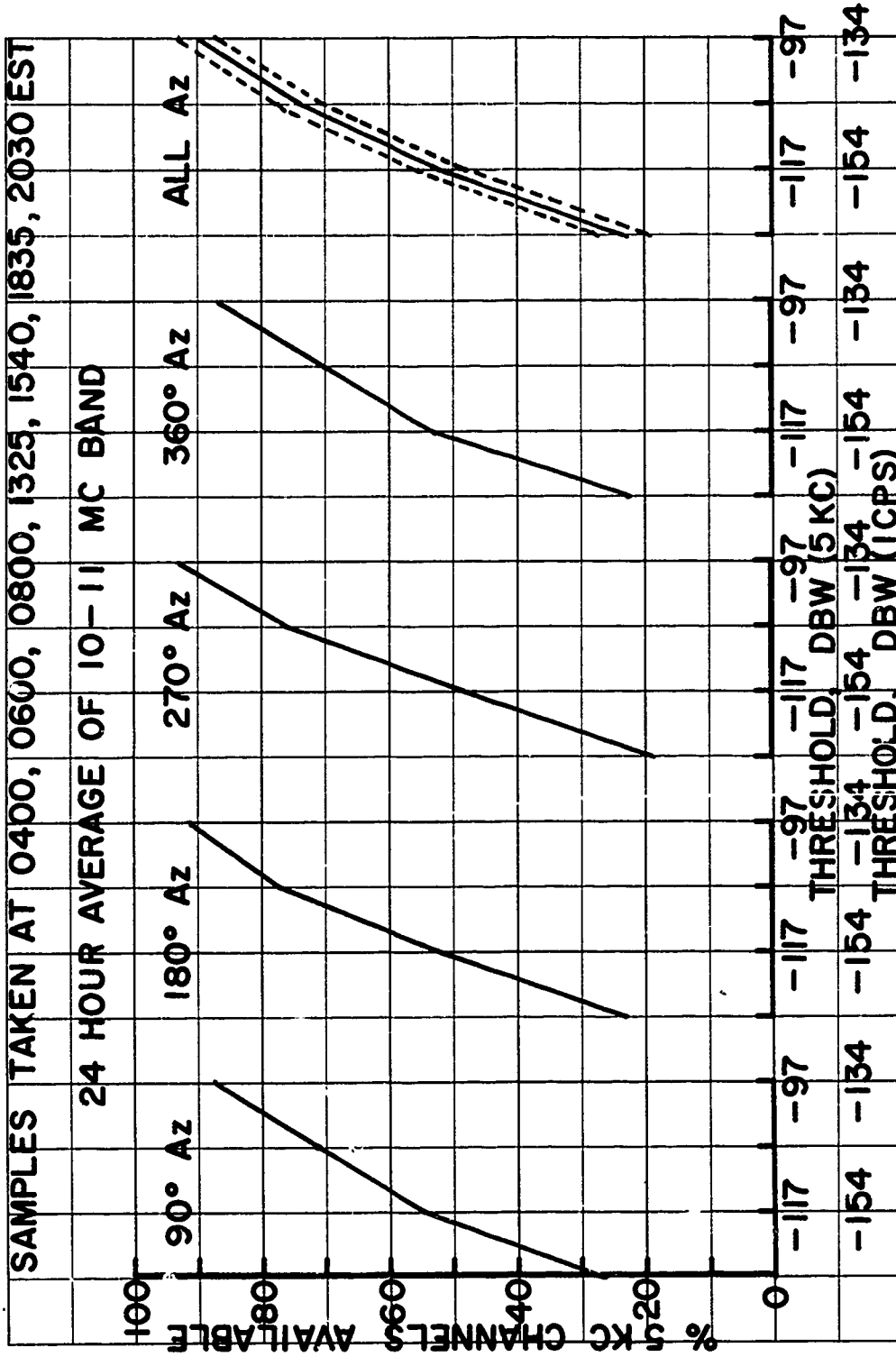

Fig. I-10 - Percentage of 5-kc channels available vs threshold level

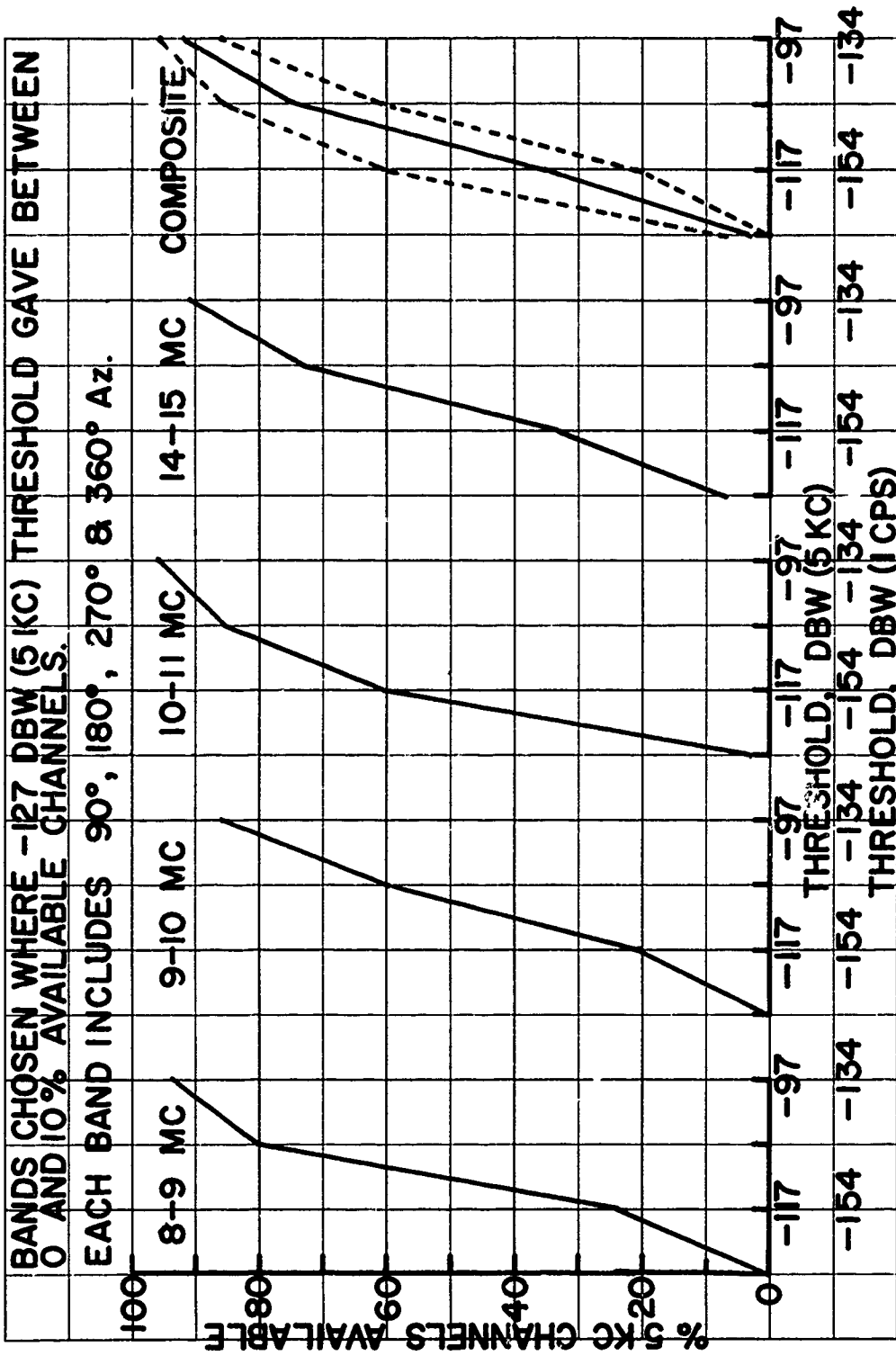

Fig. I-11 - Percentage of 5-kc channels available vs threshold level

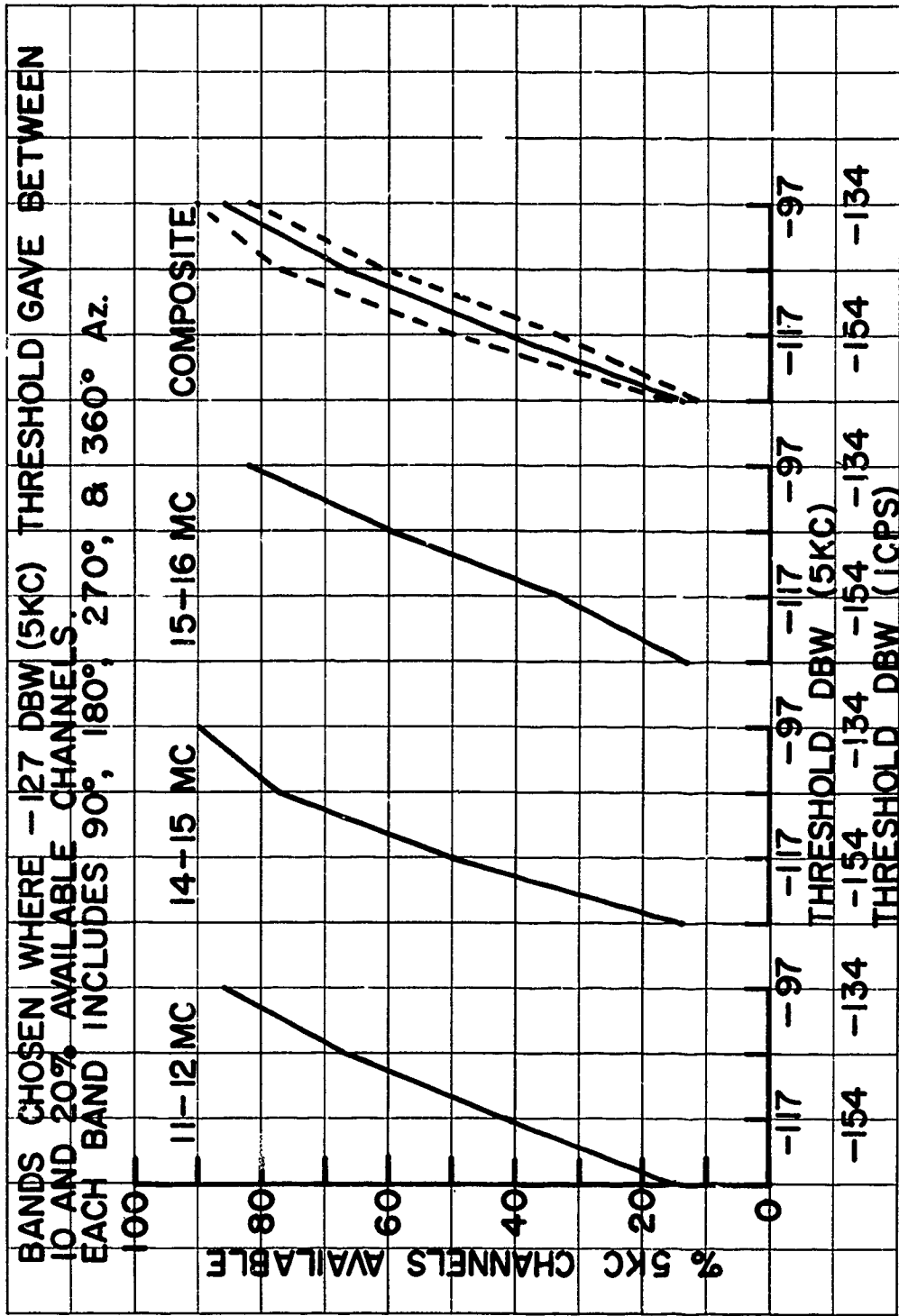

Fig. I-12 - Percentage of 5-kc channels available vs threshold level

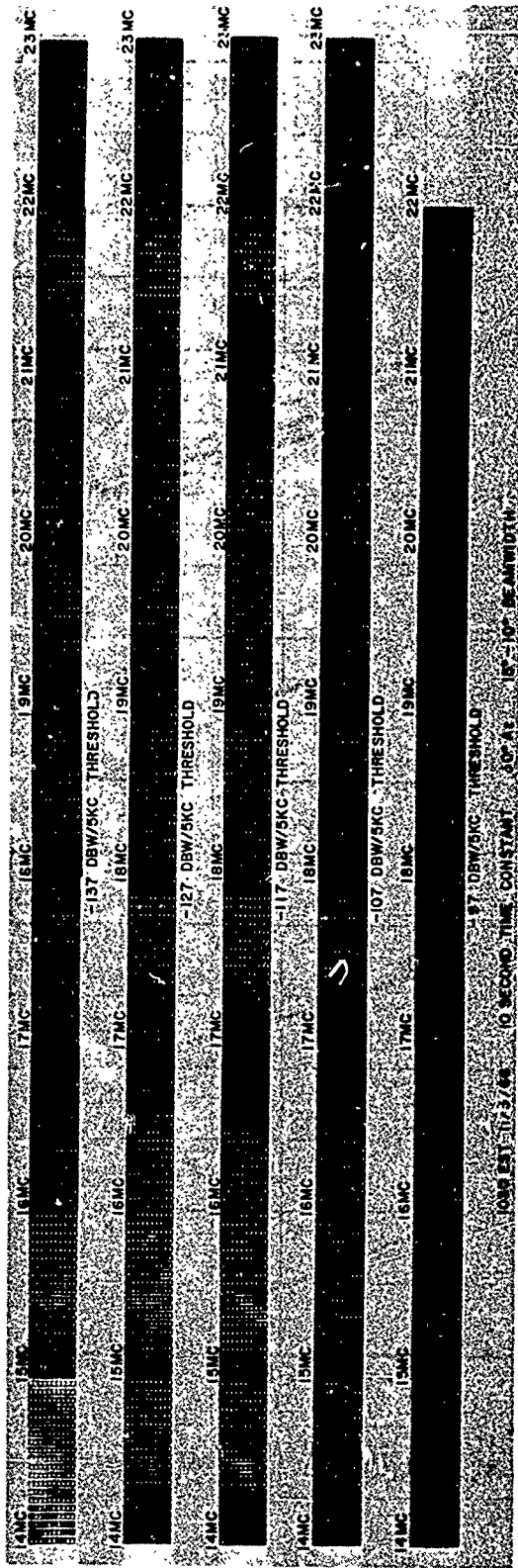

Fig. I-13 - Channel occupancy, 50° Az, 1030 EST 11/3/66

SECRET



17

Fig. I-14 - Channel occupancy, 70° Az, 1115 EST 11/3/66

SECRET

SECRET

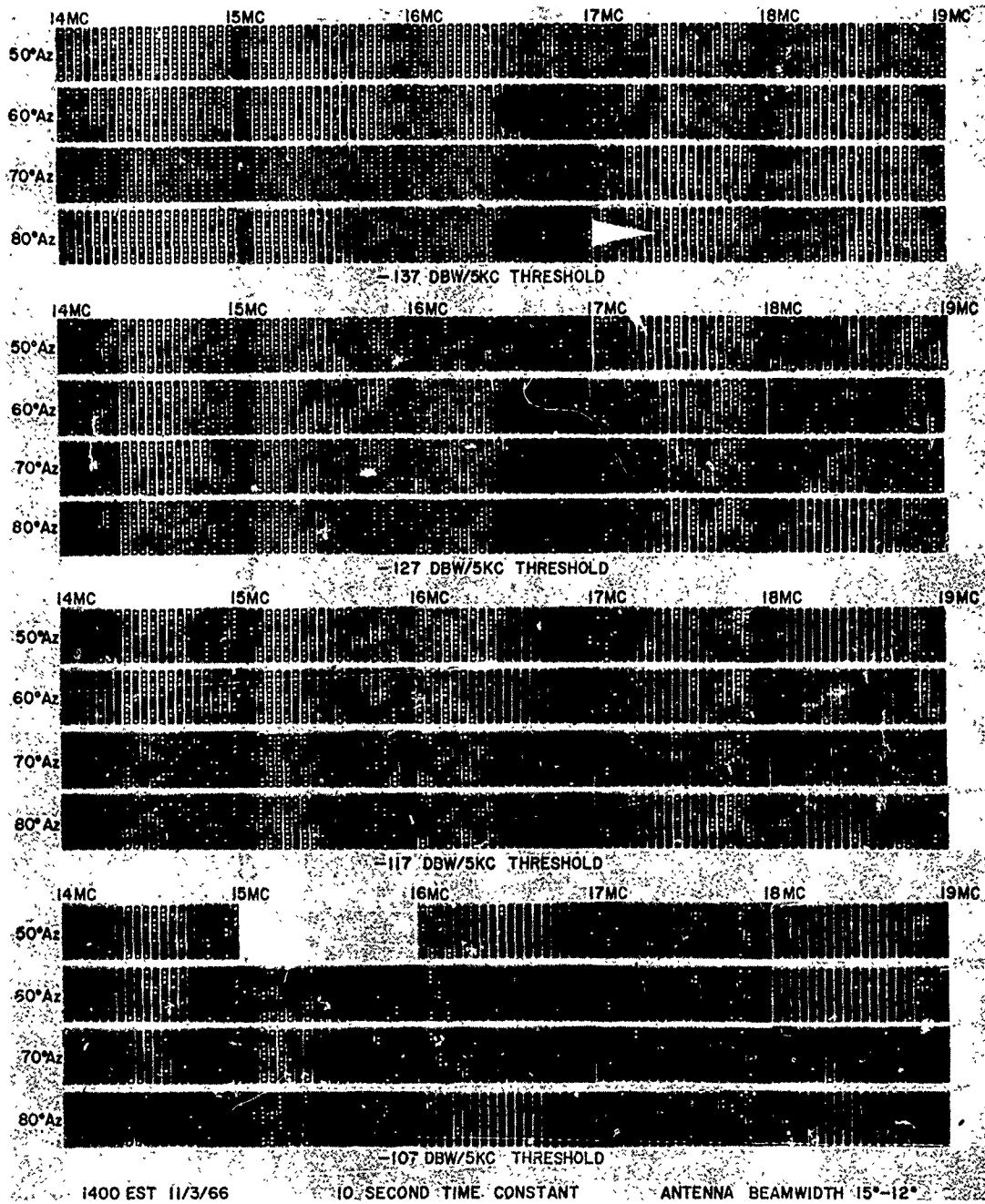

Fig. I-15 - Channel occupancy azimuth comparison, 1400 EST 11/3/66

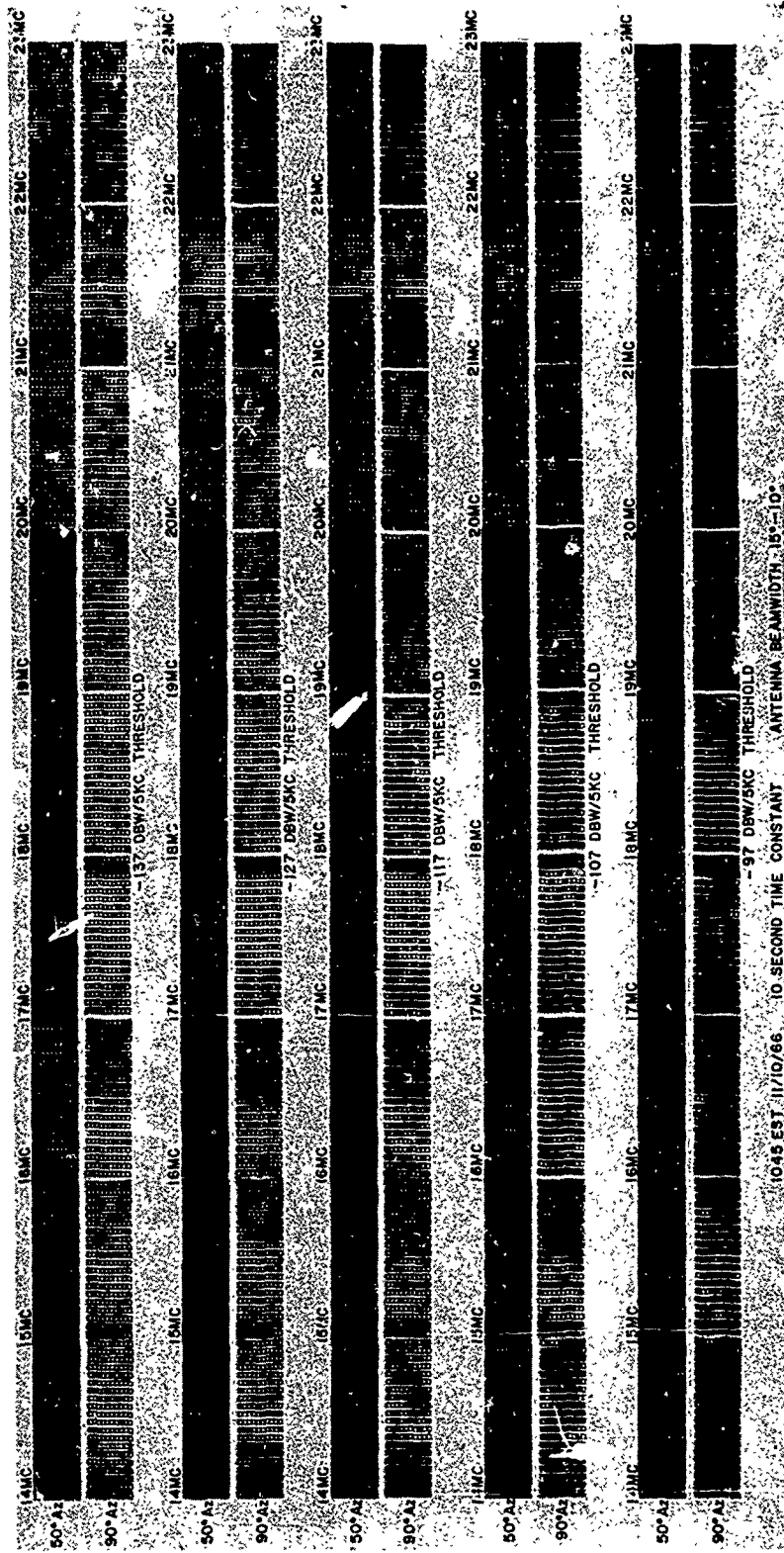

Fig. I-16 - Channel occupancy azimuth comparison, 1045 EST 11/10/66

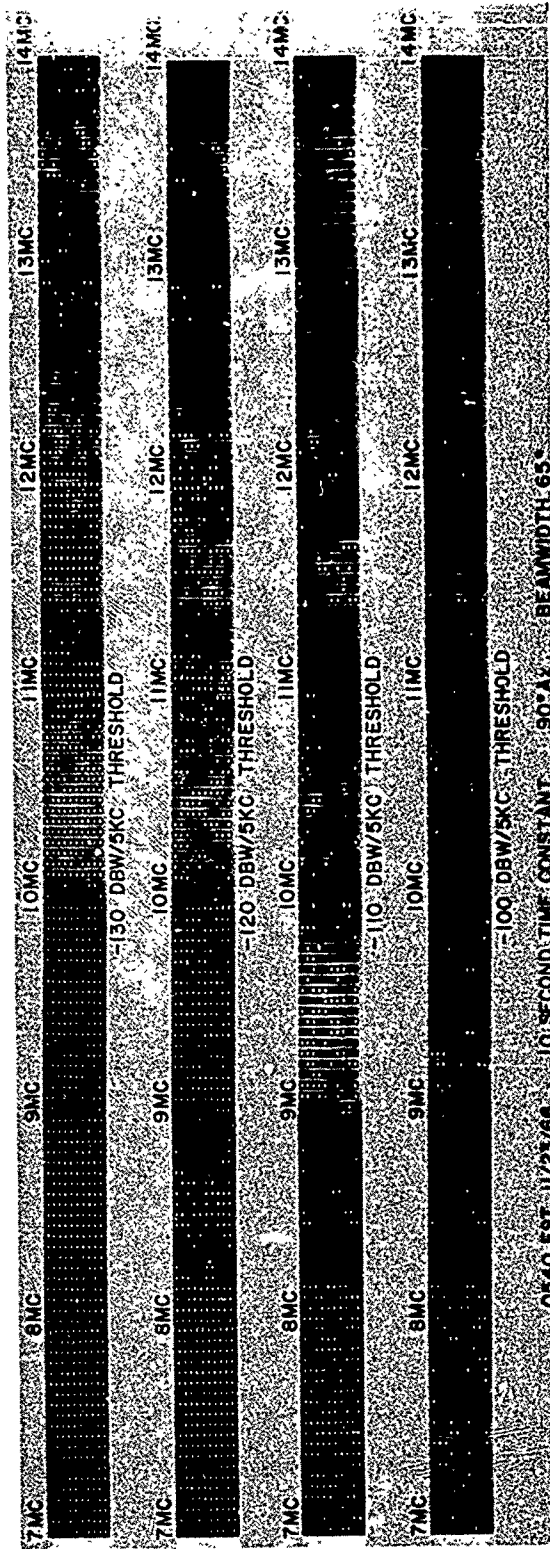

Fig. I-17 - Channel occupancy, 90° Az, 0540 EST 11/23/66



Fig. I-18 - Channel occupancy, 270° Az, 0600 EST 11/23/66

SECRET

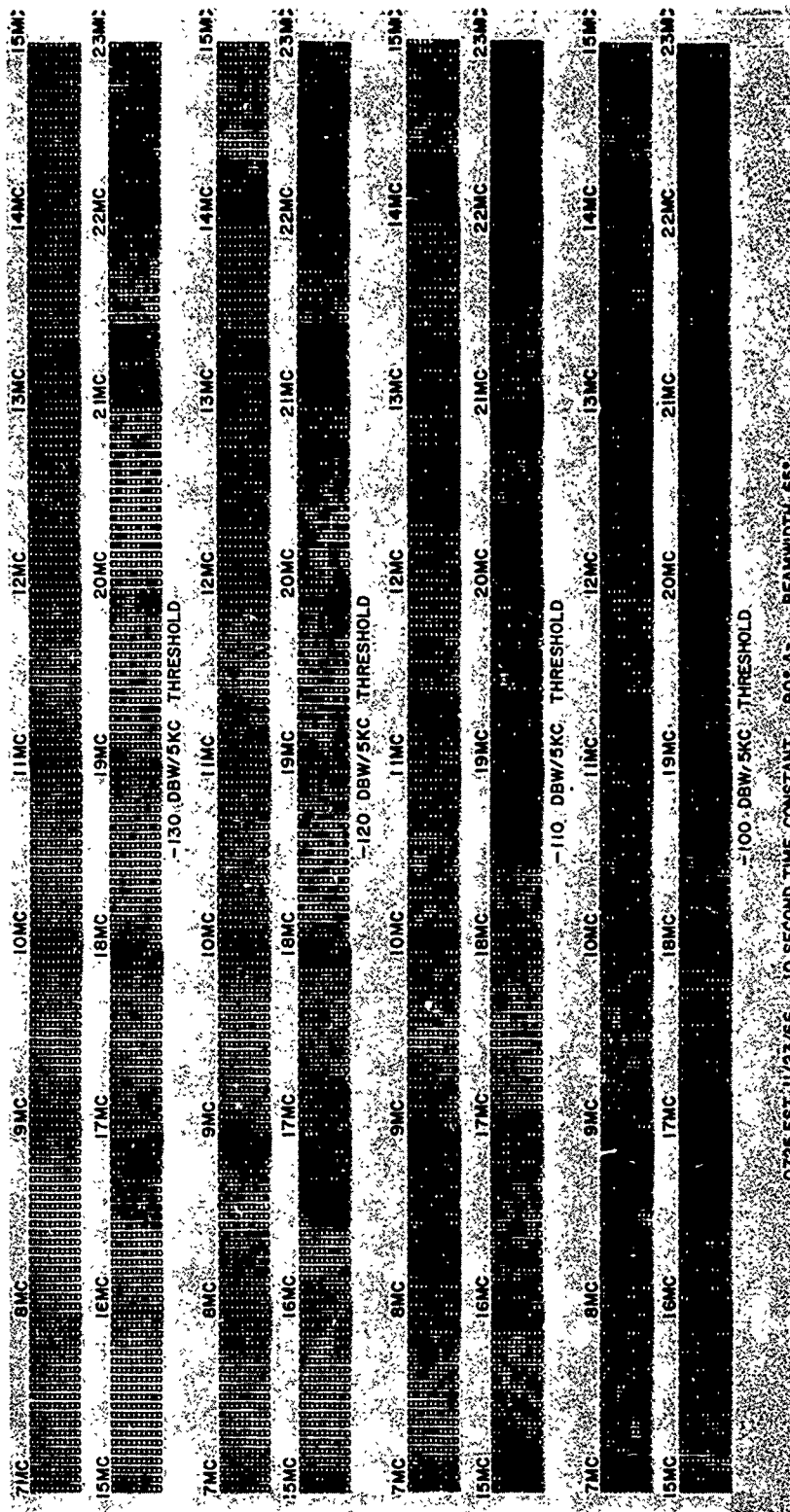
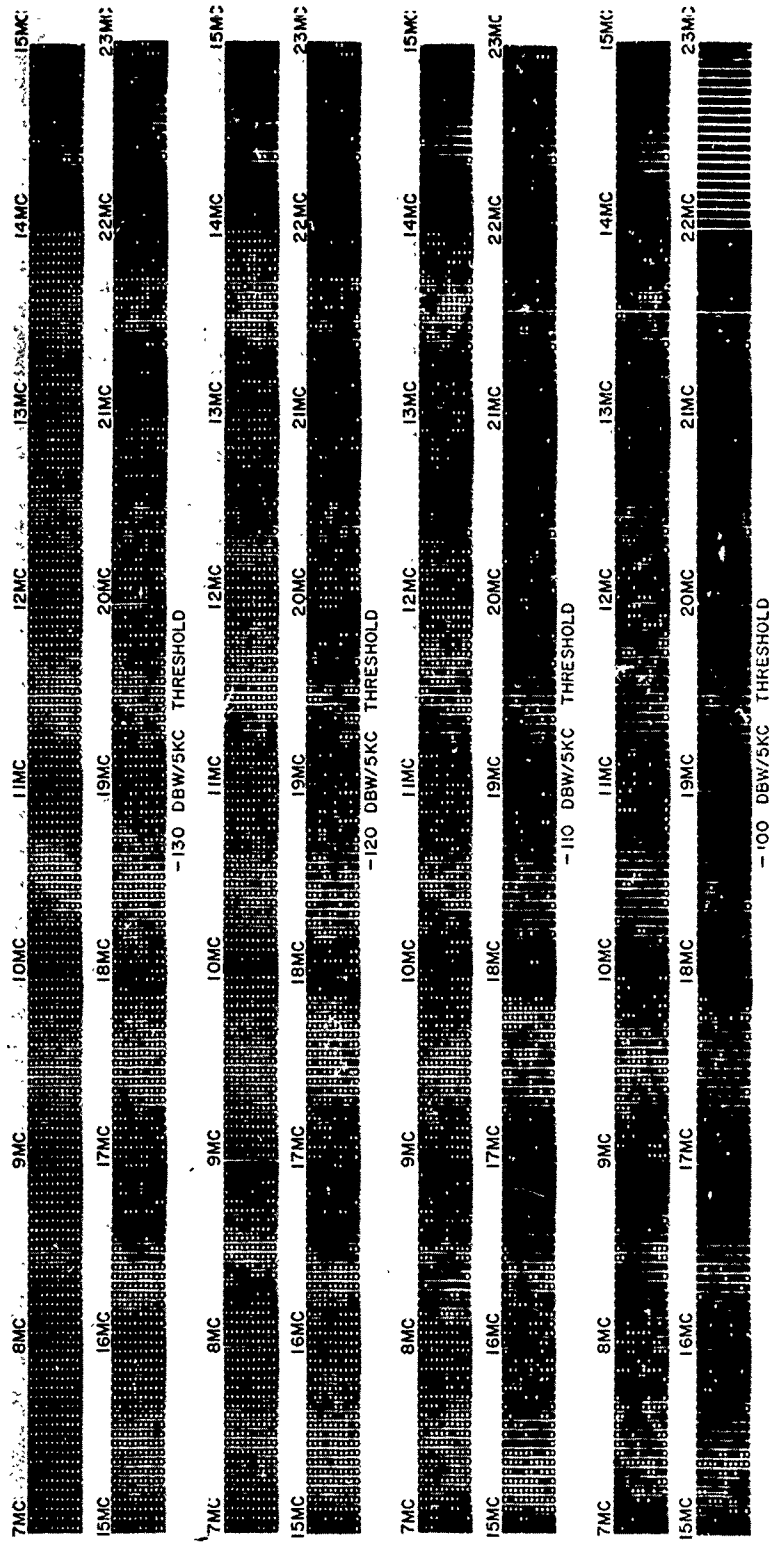

Fig. I-19 - Channel occupancy, 90° Az, 0725 EST 11/23/66

SECRET

SECRET



0800 EST 11/23/66 10 SECOND TIME CONSTANT 270° Az BEAMWIDTH 65°

Fig. I-20 - Channel occupancy, 270° Az, 0800 EST 11/23/66

SECRET

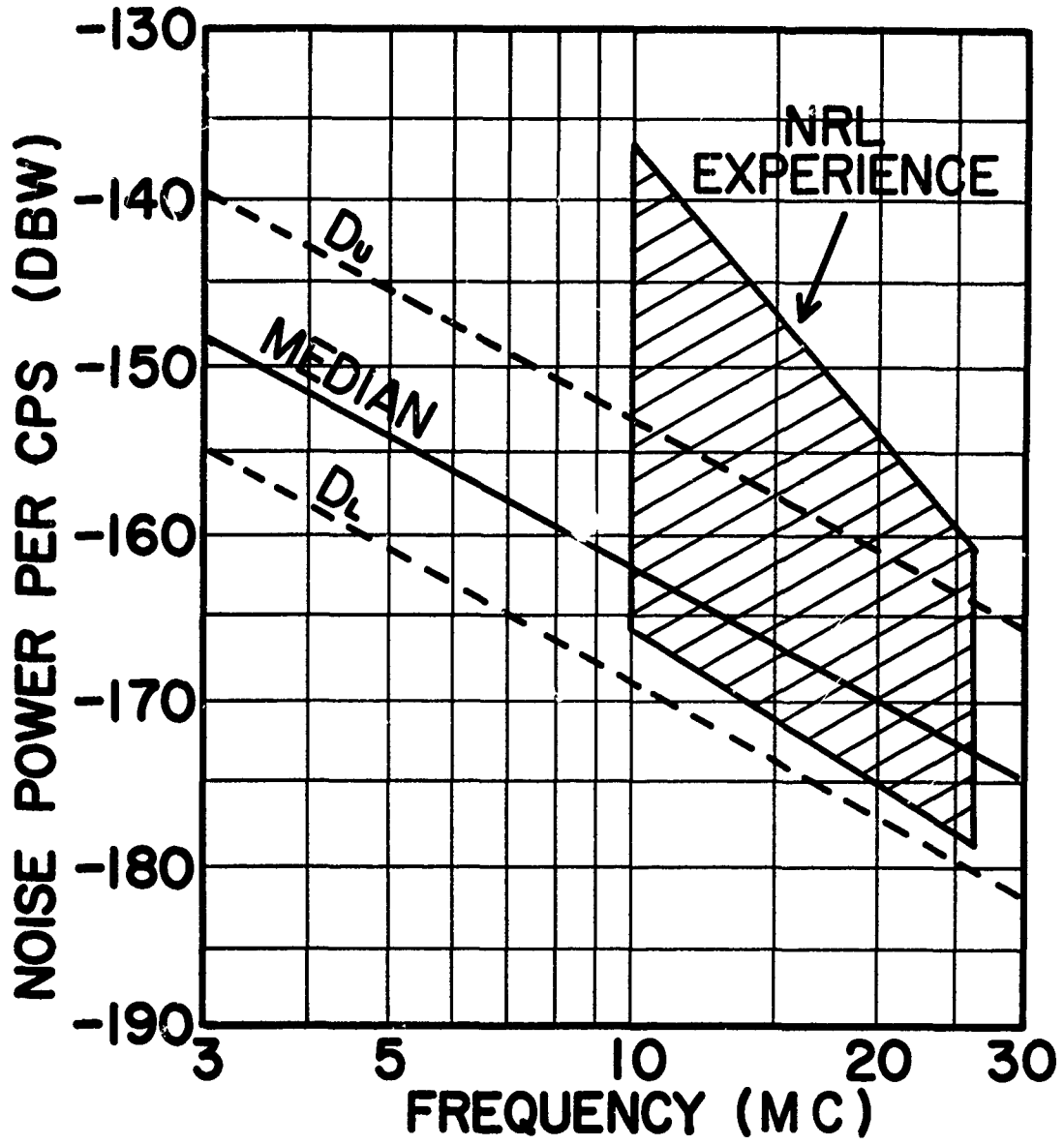

Fig. I-21 - "Rural noise" distribution and NRL experience

SECRET

PART II. SIGNAL ANALYSIS EXAMPLES

Frequency analysis of a remote broadcast station can show features of a point to point path and demonstrate some features of a radar with a narrow azimuthal beam. Figure II-1 is a frequency ("doppler") time history of WWV (Ft. Collins, Colo.) signal peak amplitudes made near Washington, D.C. This could have been received by mixed E and F path, but still the spectrum is tight and for most of the time evidence of paths by no more than two highlights is evident. Figure II-2 gives a range gated doppler time history of the earth backscatter via an E path. Even though the antenna horizontal beamwidth was about 35 degrees the spectrum is narrow. Figures II-3 and 4 are a similar pair except the earth echo is from the area around WWV and is via F propagation. In both cases the point to point circuit appears to be via ionospheric "highlights" of life times running between tens of seconds and minutes.

Aircraft target doppler analysis can show frequency integrity of the path, within the target and doppler processing limitations. Figs. II-5 a-f show results from tracking a nominal constant velocity aircraft at about 1900 nmi. Amplitude versus frequency analyses of the target signal taken at about 6 second intervals are given at the top; the amplitude of the peaks is plotted at the bottom. The frequency content of the returns are close to the resolution bandwidth of the analyzing filter, about 0.1 c/s. There is some evidence of a frequency change with each cycle of the fading pattern but the frequency does not wander much. Figure II-6 a-b is a condensation of Fig. II-5. The maximum amplitude doppler is plotted at the top as a solid line; the dotted lines on either side are the 6 dB points. At the bottom the maximum amplitude is plotted. The combined effects of any aircraft motion and path movement are in this display; evidently between 5 and 10 seconds coherent time could be effective for this typical example.

In the prior paragraphs examples have been given of paths with fair doppler integrity. These conditions do not always maintain and Fig. II-7a contains an example. Figure II-7a is a range gated doppler time history of the earth (actually sea) echo. The view is obviously by many short lived "highlights" with 1 to 2 cycles dispersion behavior. Fig. II-7b is the family of backscatter amplitude versus range pictures; in these one can actually see the high return spots moving from the shorter to longer ranges. These results are for a time when a long coherent processing time could not be effective and slow targets could not be distinguished by doppler methods.

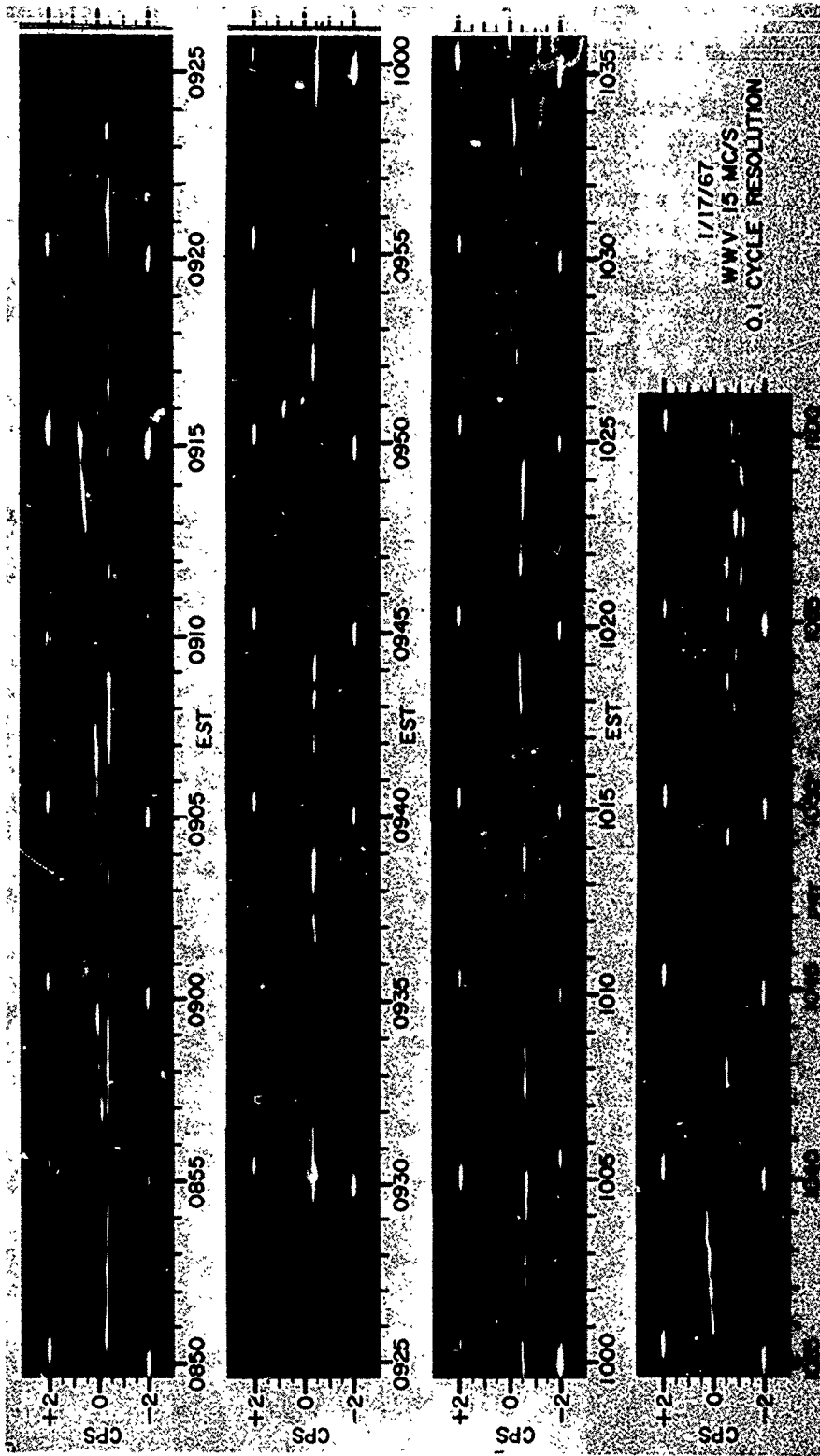

Fig. II-1 - Doppler time history of WWV via mixed E and F paths

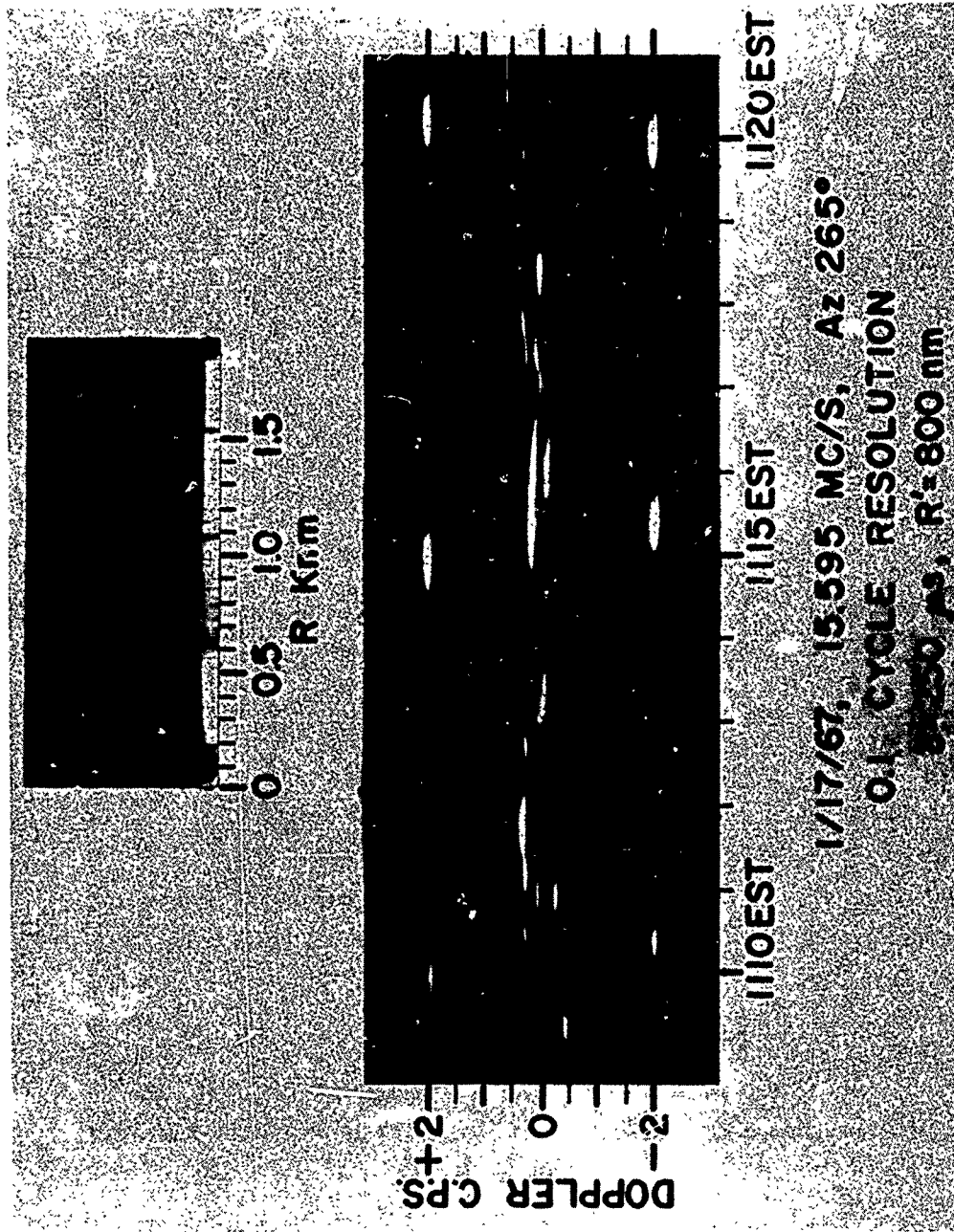

Fig. II-2 - Doppler time history for earth backscatter via an E path

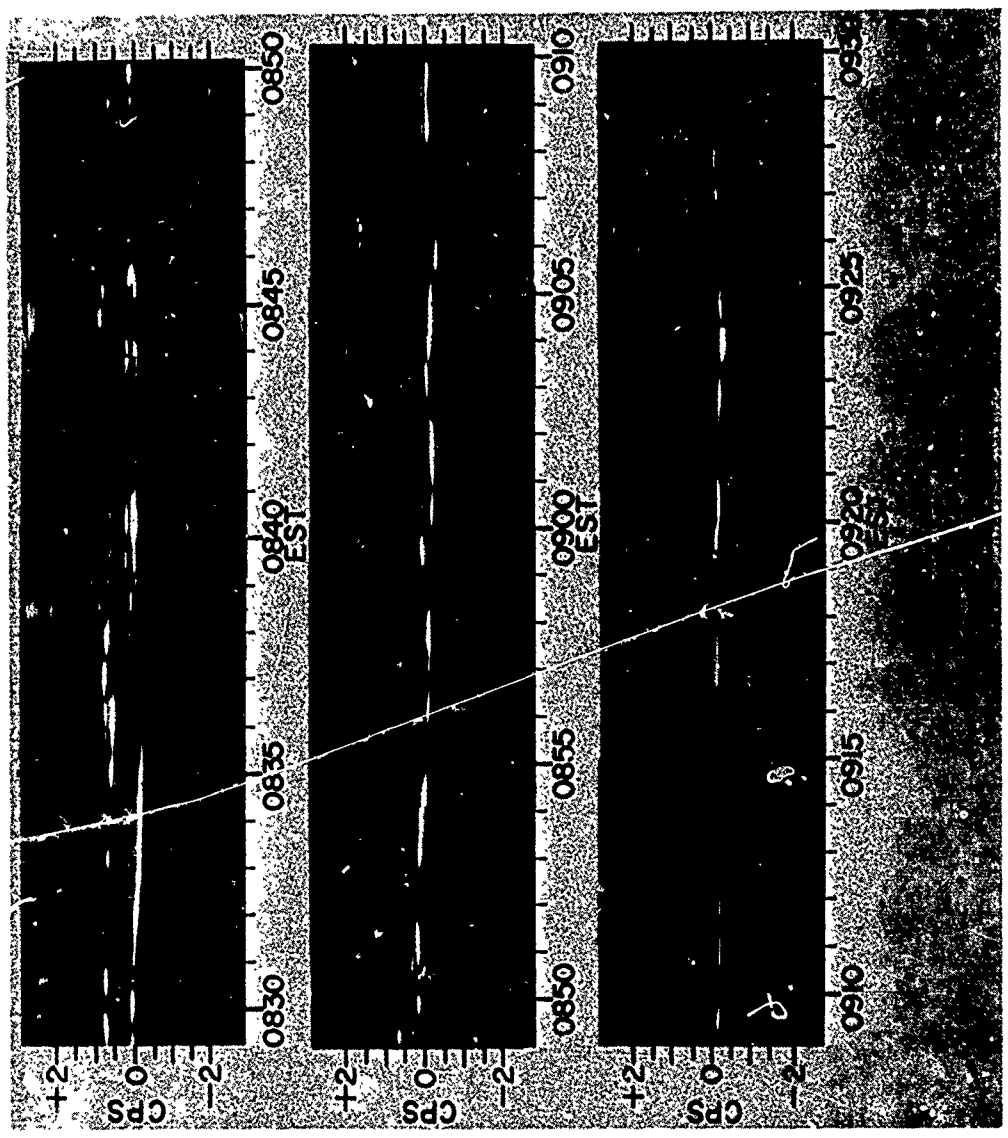
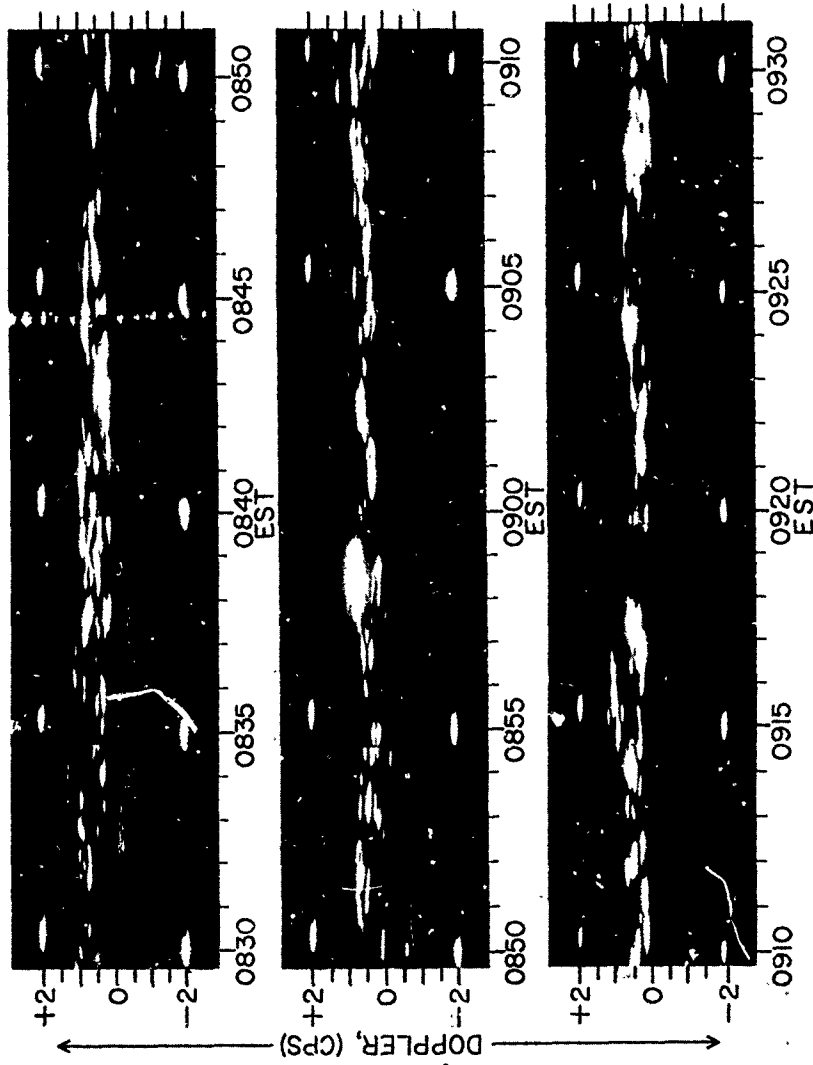

Fig. II-3 - Doppler time history of WWV via an F path

SECRET



2/21/67
Backscatter, 19:27 MC
0.1 Cycle Resolution
Sample 1600 Naut. Mi.
600 μ s Pulse

Fig. II-4 - Doppler time history for earth backscatter from Ft. Collins region via propagation

SECRET

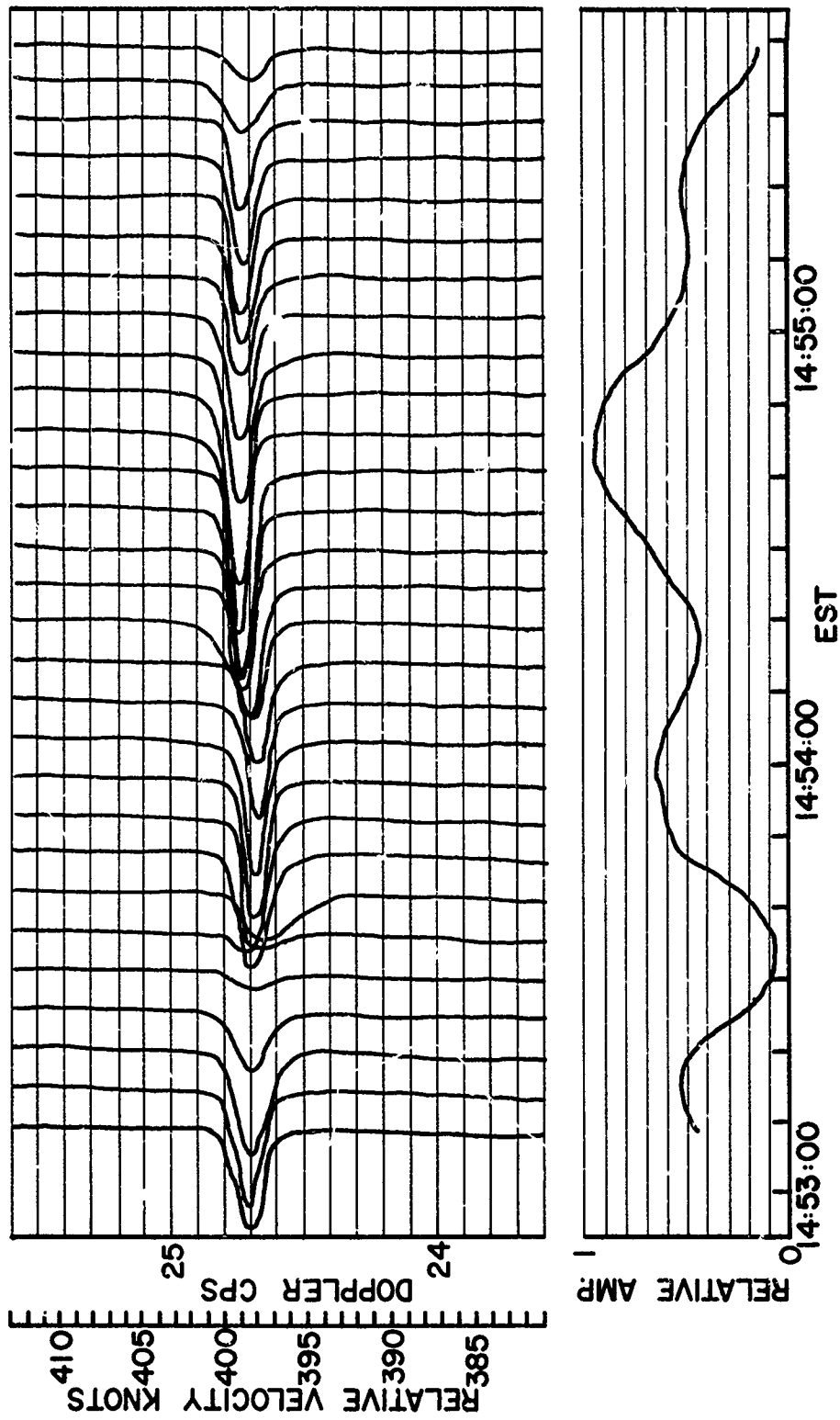

Fig. II-5a - Amplitude doppler time characteristic for a 35-minute track of a P3A aircraft

SECRET

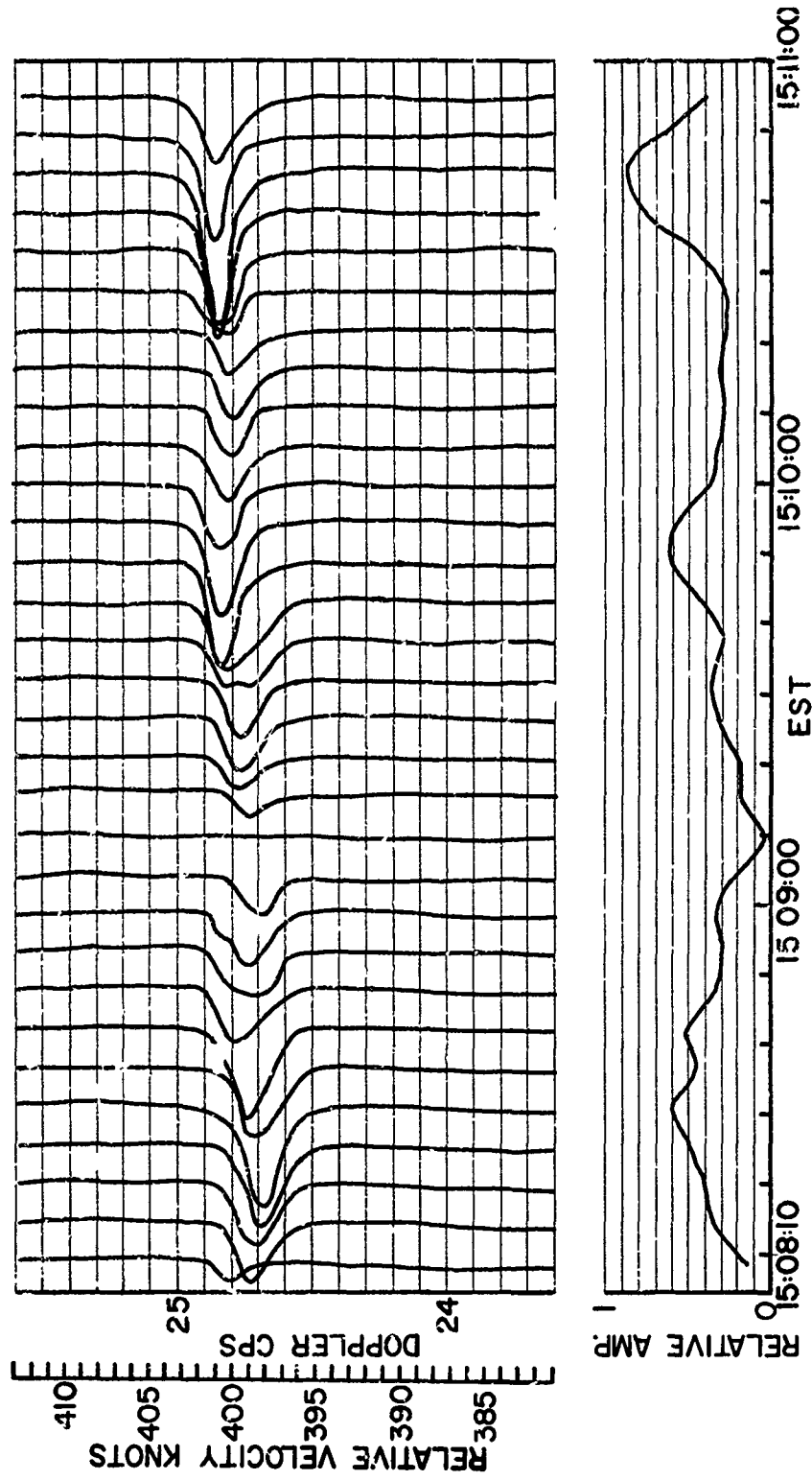
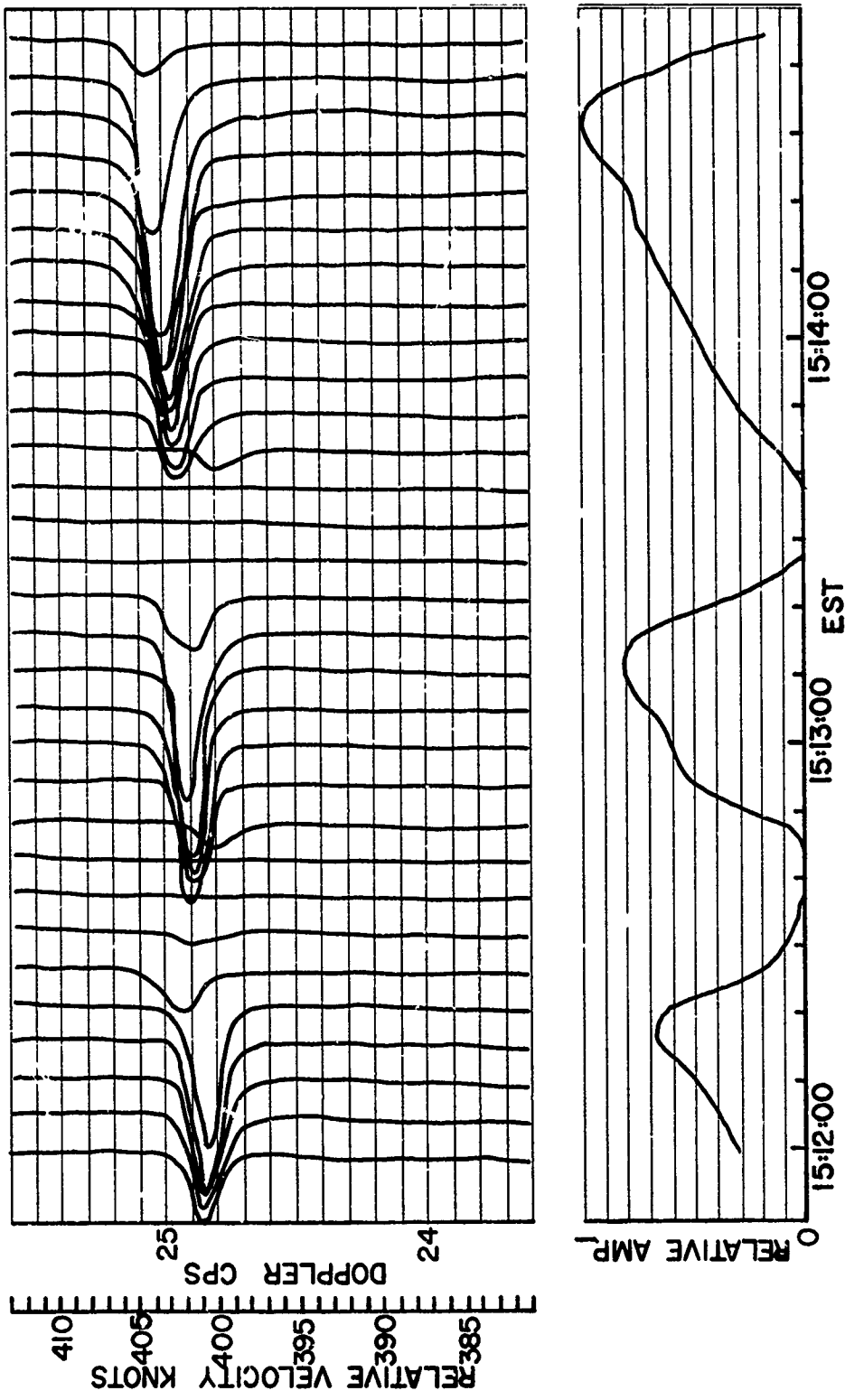

Fig. II-5b - Amplitude doppler time characteristic for a 35-minute track of P3A aircraft

SECRET



32

Fig. II-5c - Amplitude doppler time characteristic for a 35-minute track of a P3A aircraft

SECRET

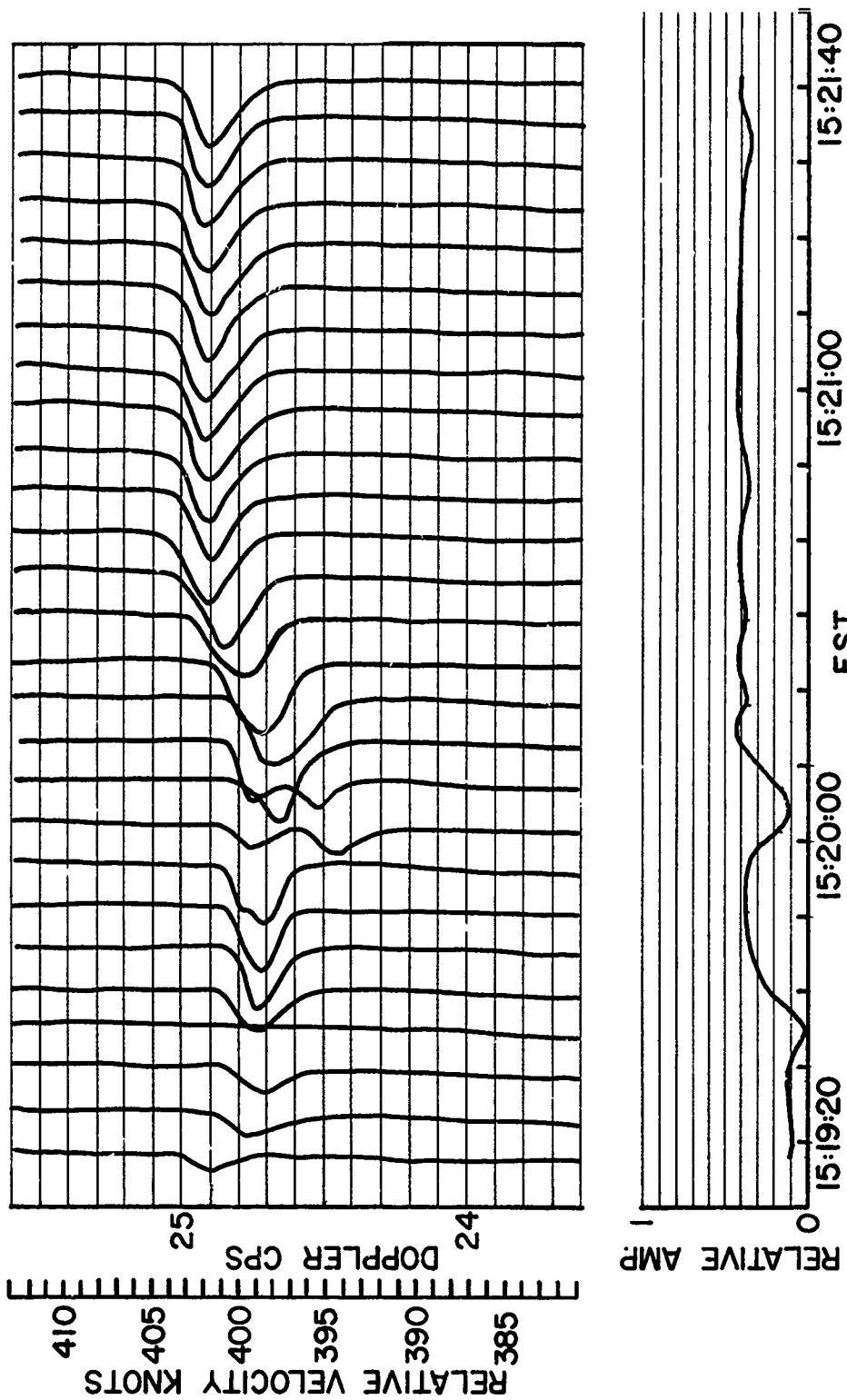

Fig. II-5d - Amplitude doppler time characteristic or a 35-minute track of a P3A aircraft

SECRET

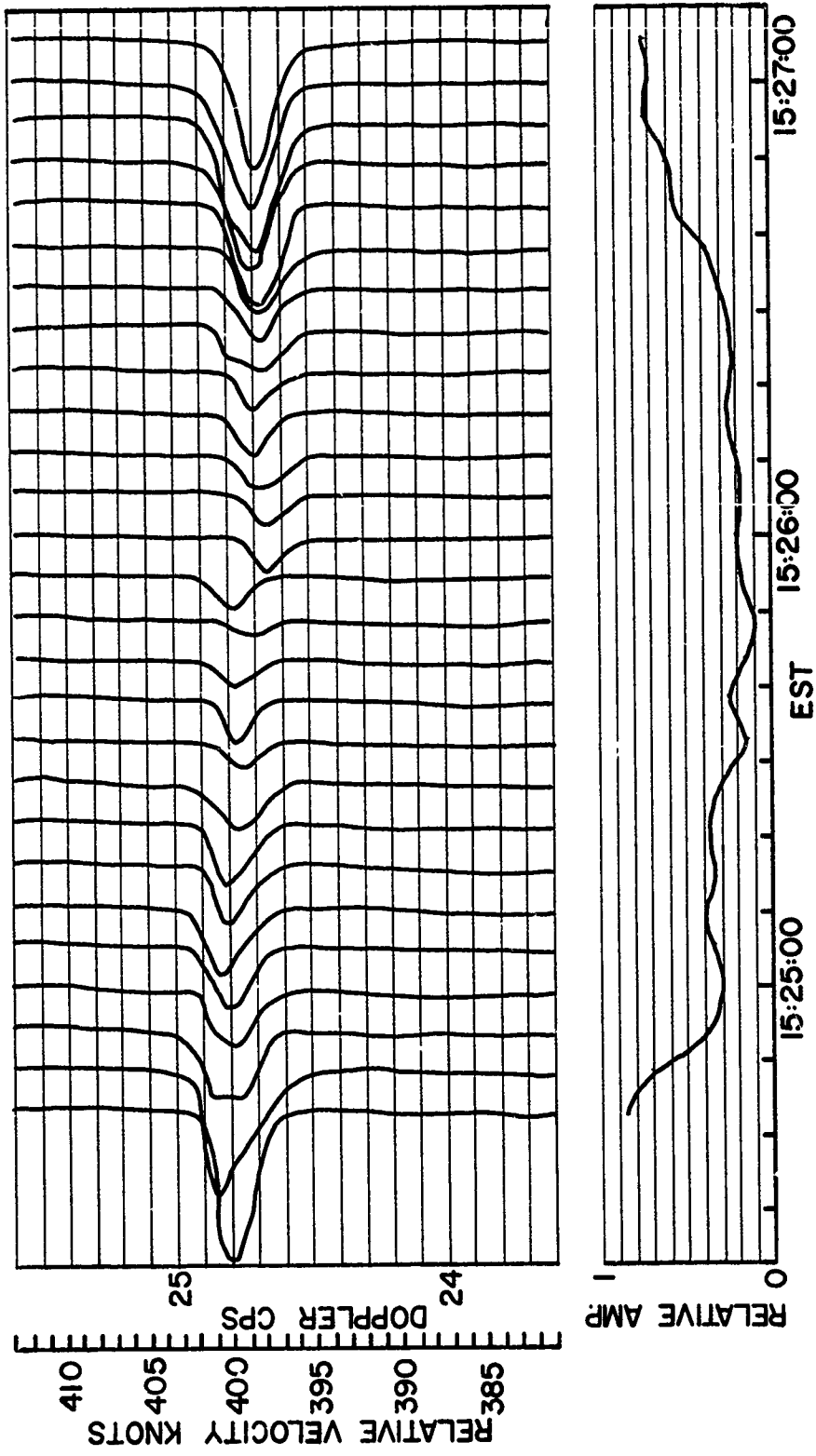

Fig. II-5e - Amplitude doppler time characteristic for a 35-minute track of a P3A aircraft

SECRET

SECRET

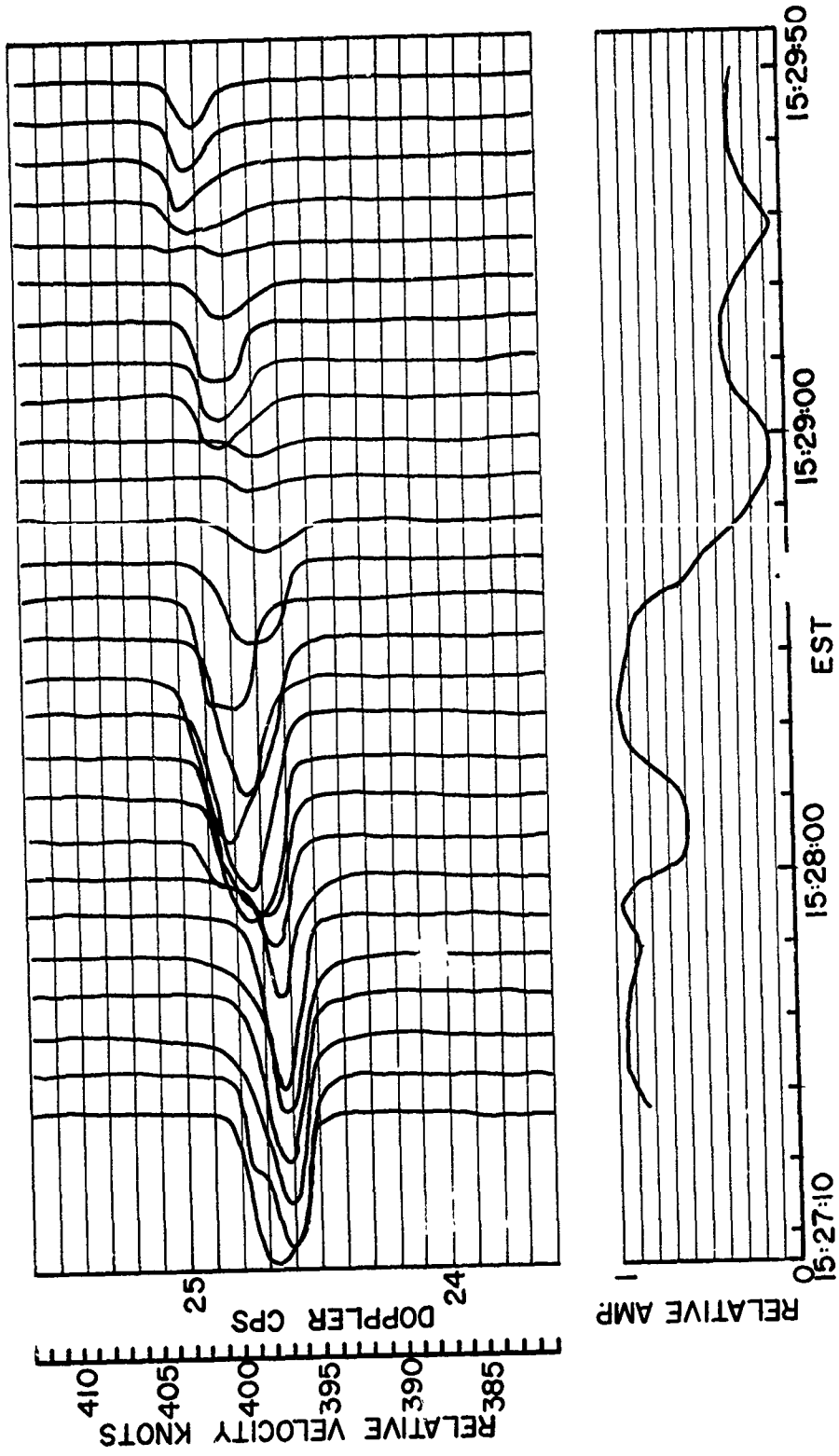

Fig. II-5f - Amplitude dopper time characteristic for a 35-minute track of a P3A aircraft

SECRET

SECRET

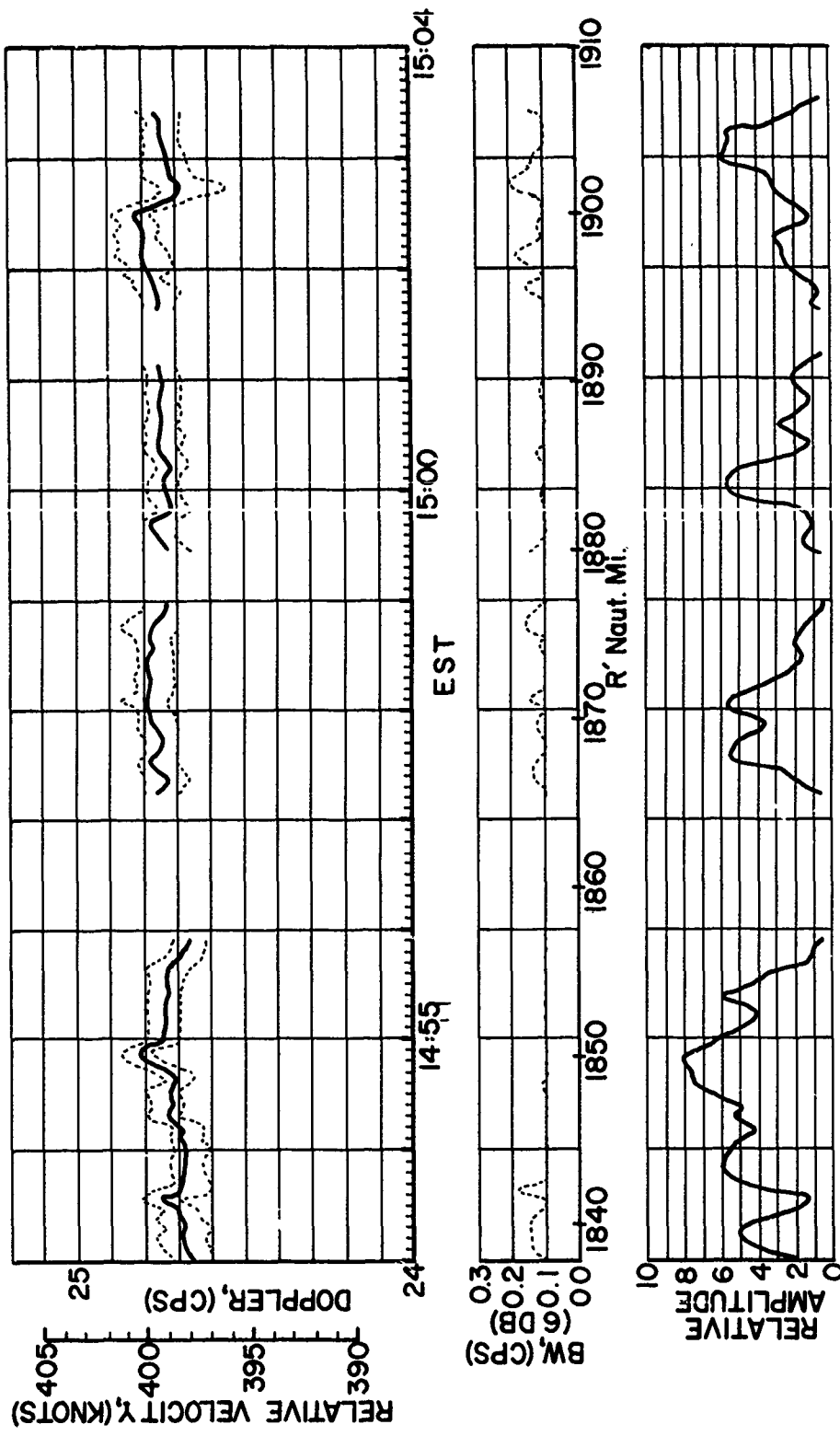

Fig. II-6a - Condensed P3A spectral and amplitude data

SECRET

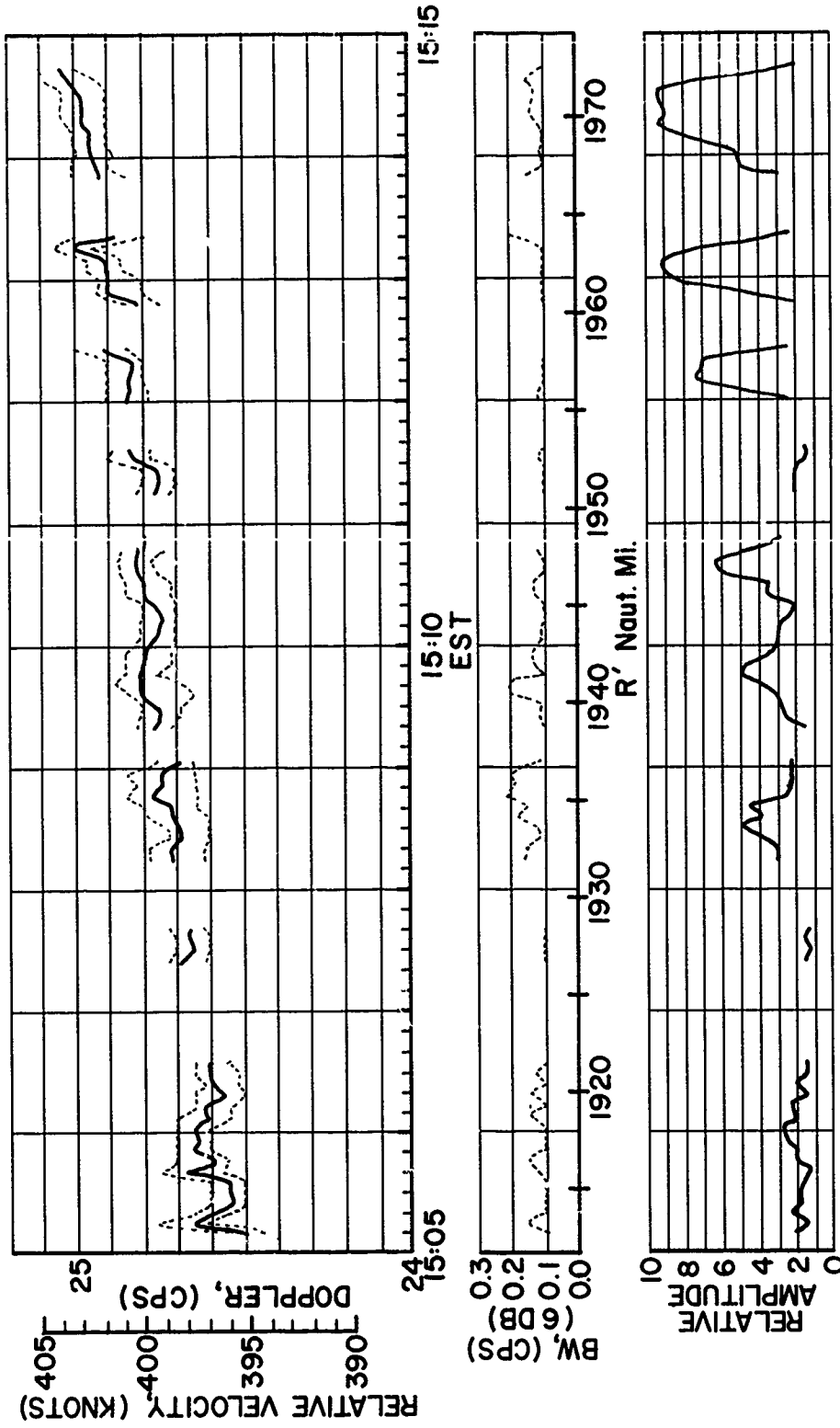

Fig. II-6b - Condensed P3A spectral and amplitude data

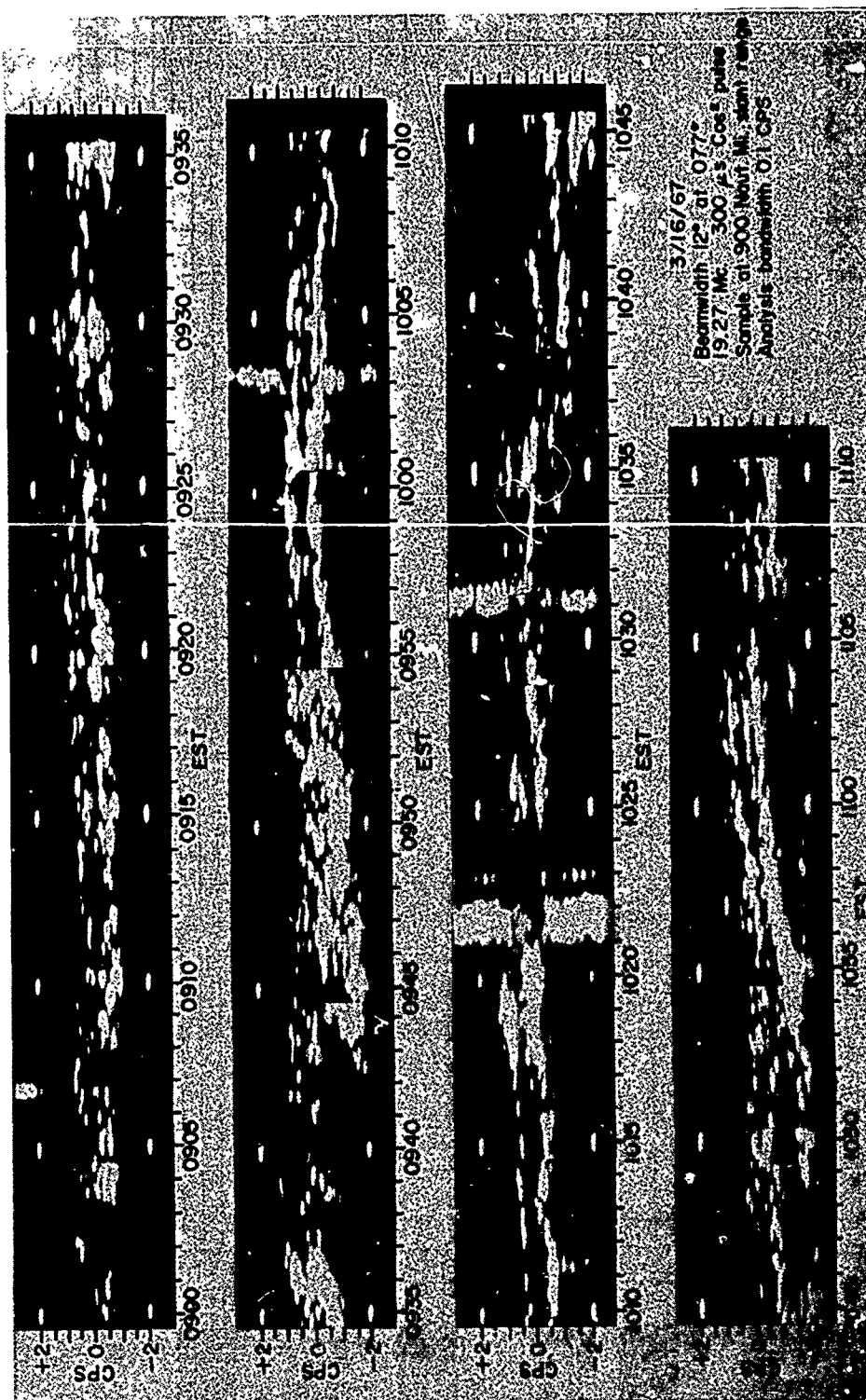

Fig. II-7a - Doppler time history for backscatter from the surface of the sea during period of short-lived highlights

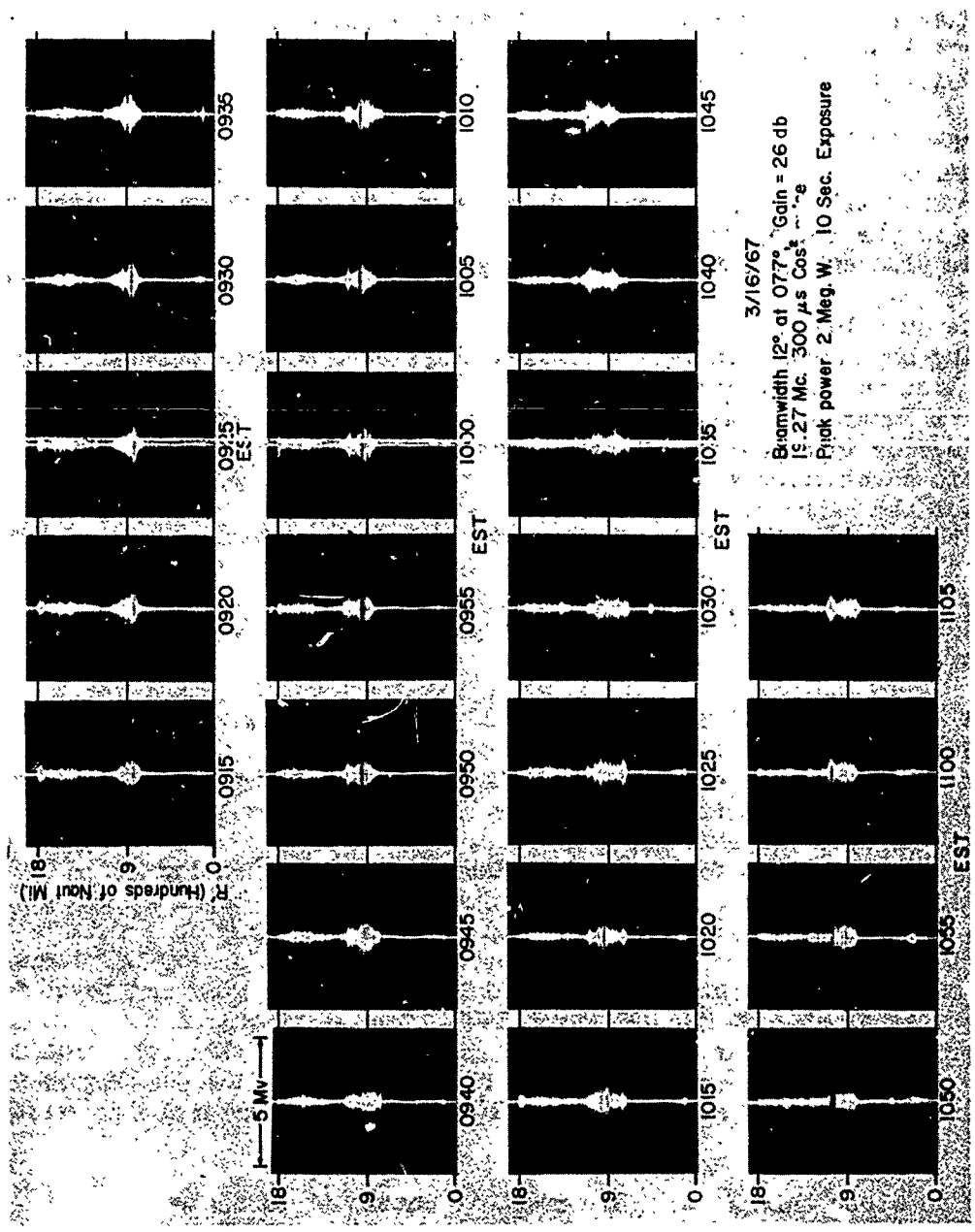

Fig. II-7b - Backscatter amplitude versus range for a 110-minute period

SECRET

PART III. SLOW SPEED TARGET TEST AND CLUTTER CHARACTERISTICS

For a number of years over-the-horizon aircraft and missiles have been detected and tracked with the Madre radar. Most of the operation has been with a signal processor and clutter filters designed to reject all of the clutter all of the time. The processor and clutter filters treat targets of very low doppler in the same manner as clutter.

Under typical ionospheric conditions the target signal can be one of the order of 3 microvolts at the antenna terminals immersed in earth backscatter of 3 millivolts or more. This represents a 60 dB range. The comb filters in the Madre system provide this kind of rejection and make possible aircraft detection and tracking.

The question does arise "What are the limitations of MTI methods for detecting slow moving targets including ships with a skywave radar?" The answer lies in the spectral character of the backscatter in which the target is immersed. There are times when the amplitude spectra is tight (i.e., narrow in bandwidth). Under such conditions an adaptive comb filter in combination with a high dynamic range doppler processor might bring out the ships or other slow targets. Under other spectral conditions it may be possible to get by without comb filters provided the processor has 60 dB or more dynamic range. There will be times when the backscatter spectra is too wide in bandwidth and too high in amplitude for any combination of filtering and large dynamic range processing to be effective for slow targets.

On January 6, 1967 there was a small informal conference on OTH Radar Ocean Surface Monitoring. The conference was held under the auspices of the Committee on Undersea Warfare of the National Academy of Sciences - National Research Council in Washington, D. C. As a result of this meeting and OPNAV interest in this area, Mr. J.J. Kane, Code 418, ONR, arranged a ship surveillance test for the end of March. The test was for ITT-EPL, Riverdale, Md.; however, ESSA-ITSA, Boulder, Colorado (Lowell Tveten's group), and the NRL Madre radar at Rangle Cliff, Md., made observations during the test period. The plan as carried out placed a Navy LST approximately 800 nmi from Washington, D. C. at 26°N 72°W (the starting point for the test) at about 1 PM EST, 21 March 1967. The ship cruised at 15 knots for approximately 2 hour periods on headings which gave alternate broadside and bow or stern on aspects referenced to a radial from the Washington area. The course pattern was similar to a square wave and progressed from west to east.

Among other things the Madre radar is committed to a study of sea clutter at HF. This work is sponsored by RADC; (Mr. Kenneth Stiefvater is the project engineer). This LST test was used as an opportunity to examine backscatter spectral returns from the ocean surface in the region of a known ship target and from which sea conditions would be observed.

SECRET

SECRET

The Madre radar operated on two days during the test. On the first day, 21 March, the radar operated from 1 - 6:30 PM EST. On the second day, 22 March, data was recorded from 10:15 - 11:25 AM and from 1:15 - 3:30 PM EST. During both days data was taped for later doppler processing and analysis, however, during the second day, 22 March, spectral data was simultaneously taped and recorded on 16 mm film.

During the operating periods on both days the sea and weather conditions were stable. During the operating time on 21 March sea state 4 was recorded in the ship's log. Waves were 5-6 ft. in height with 5 second periods. On 22 March the sea state was 3 with 3-4 ft. waves and periods of 7-8 seconds. During both days wind direction was approximately at right angles to the radial from the Madre site to the LST. The wind was coming from 50° to 70° relative to true north.

A representative portion of the data is shown in Fig. III-1 through III-8. Figures III-1 and 6 are amplitude-range pictures which cover the period of operation. Calibration spikes appear at 450 nmi intervals and correspond to 1 mV p to p signals at the radar antenna terminals. On Fig. III-1, the first calibration signal appears at 375 nmi while on Fig. III-6 the first mark appears at 450 nmi. Time (EST) appears above each frame. Operation during the morning was at 19.27 Mc with an antenna beamwidth of 31°. During the afternoon's operation at 15.53 Mc the antenna beamwidth was 37°. For both cases the transmitted pulse was a 300 micro-second cosine squared pulse.

During the time interval covered by Figs. III-1, 2, 3, 4, 5 the LST was cruising broadside at a ground range of 889 nmi from the Madre radar site. Figures III-2 and III-3 show spectral amplitude scans at 90 second intervals from a range gate covering 805 to 845 nmi. This range gate doesn't cover the LST's position, however, Figs. III-4 and 5 show spectral data from a wider gate extending from 850-930 nmi. This second gate covers the LST position.

The spectral scans were made during the test every 2.8 seconds and each scan was photographed on a single frame of 16 mm film. Figures III-2, 3, 4, 5 contain single frames taken from the 16 mm film at 90 second intervals. Here two synthesizers are used to provide reference signals 2 cycles above and 2 cycles below the carrier. The resolution is 1/10 cycle and the calibration level corresponds to a $0.7 \times 10^7 \text{m}^2$ target at 825 nmi (the middle of the first gate) and a $0.9 \times 10^7 \text{m}^2$ target at 890 nmi (the middle of the second gate). The gate can be varied in both range and doppler extent. During this test the doppler gate was set at a 5 c/s width which is adequate to show all backscatter components. The analyzer (drum) storage time is 20 seconds.

Figures III-7 and III-8 represent spectral scans taken during the afternoon of 22 March. The frequency was lowered to 15.53 Mc to maintain

SECRET

SECRET

coverage of the LST position. At 14:14 EST the LST was at checkpoint 12 which was 859 nmi from the radar. Prior to 14:14 the ship was moving along the radial toward the Washington area (bow aspect); at checkpoint 12 it turned 90° and proceeded east presenting a broadside view. The ship continued on the broadside course until it reached checkpoint 13 at 1630.

In Figs. III-7 and III-8 a $0.9 \times 10^7 \text{m}^2$ target at 900 nmi would present the same level signal as the calibration. In all the spectral pictures a signal 20 dB below the calibration level corresponding to a $\sigma \sim 10^5 \text{m}^2$ would just be visible. Close examination of Fig. III-7 prior to 14:14 reveals nothing which one might call a 15 knot ship. During this period the LST was cruising along a radial toward Washington. Its doppler would be about 0.8 cycles on the high side of the carrier. Earlier this year Mr. Joseph Green of IIT-EPL made some model cross section measurements on a destroyer of the Fletcher Class. He measured a $\sigma \approx 7 \times 10^3 \text{m}^2$ at bow aspect with vertical polarization for an equivalent HF frequency of 7.41 Mc. Values for the LST should be within a few dB. From these figures it appears that the LST was probably 20 dB lower in cross section than our minimum detectable cross section. Broadside measurements gave $\sigma = 1.7 \times 10^5 \text{m}^2$.

Figure III-9 shows a doppler time record made by Lowell Tveten's group (ESSA-ITSA Boulder, Colorado) of the sea scatter at the range and bearing of the LST as viewed from Boulder. Prior to 1730 GMT the clutter spectrum appears to be mixed and unsettled. Similar effects are noted in Figs. III-2, 3, 4, 5 of the NRL record. After 1730 GMT the ESSA spectral record has two peaks, one above and the other below the carrier. Similar peaks appear in the NRL data as shown in Figs. III-7 and III-8.

In summary this test produced expected results. It appears that at times a slow moving target should be visible on a spectral basis provided there is sufficient dynamic range. Our future plans involve operation against ship targets of opportunity using a higher gain antenna and the new 60 dB dynamic processor.

On April 13, 1967 spectral backscatter data was taken during sunrise. Operation was at 13.67C with the antenna slewed to 90° and horizontal beamwidth 15°. About an hour's spectral data was taken in a manner similar to that during the LST test. A 40 nmi gated portion of the backscatter was analyzed. Time of operation extended from about 4 AM to 5 AM EST. As the backscatter comes in it has a spectral width of about 1.5 c/s displaced about 1.5 c/s above the carrier. With time the spectral width decreases and the spectral position of the backscatter moves closer to the zero doppler position. These effects are shown in Fig. III-10. Some of the frames have spikes at + 2 c/s. These are doppler calibration marks. It was not possible to place the 40 nmi gate at a fixed position in range and still receive signals of useful amplitude during this hour's sunrise period. The backscatter as a whole closes in range during this period. At 4:15 AM EST the gate position was 1600 nmi, at 4:35 gate was moved to 1450, at 4:45 gate at 1375, and 4:55 gate at 1270.

SECRET

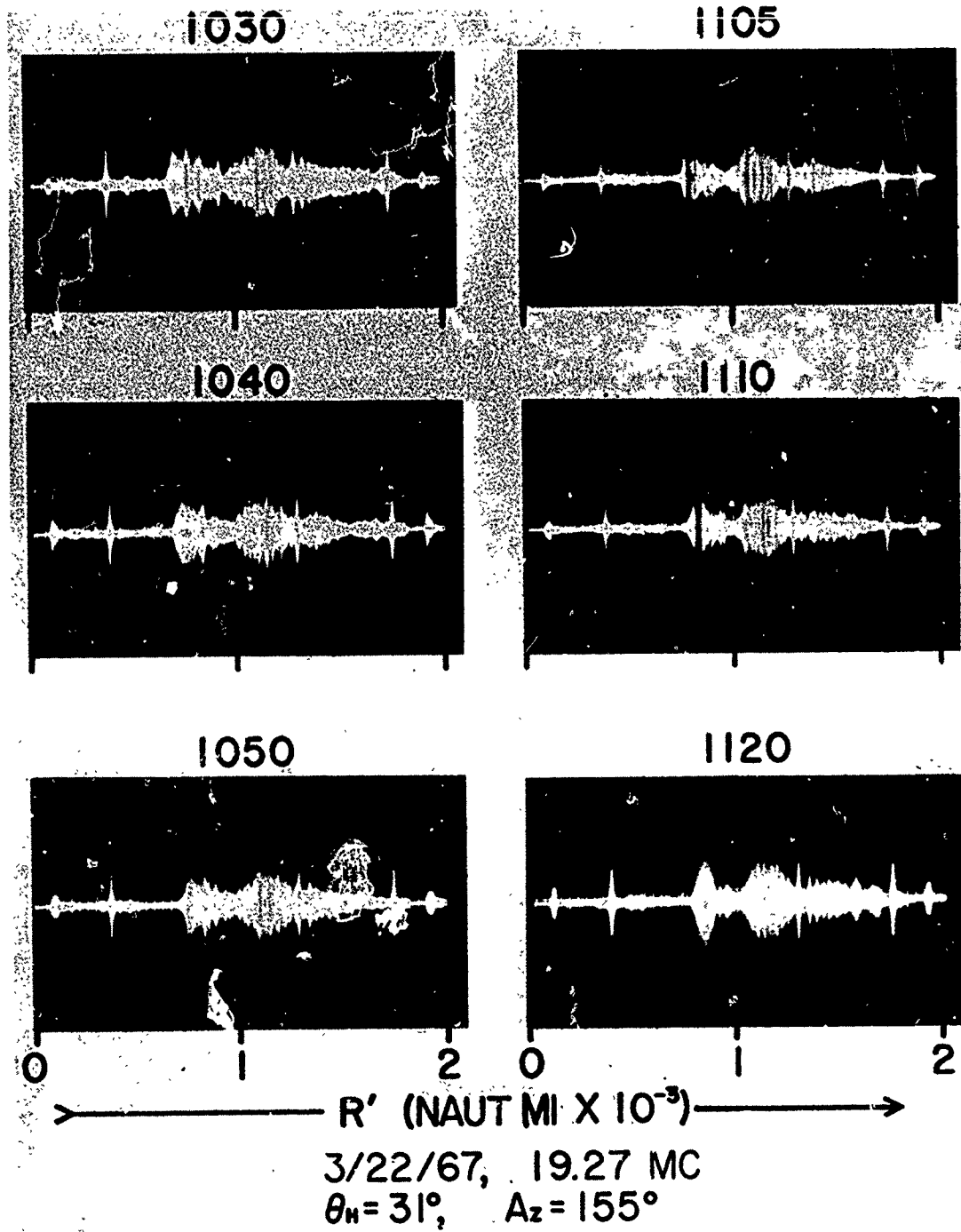

Fig. III-1 - Backscatter amplitude versus range at 19.27 Mc

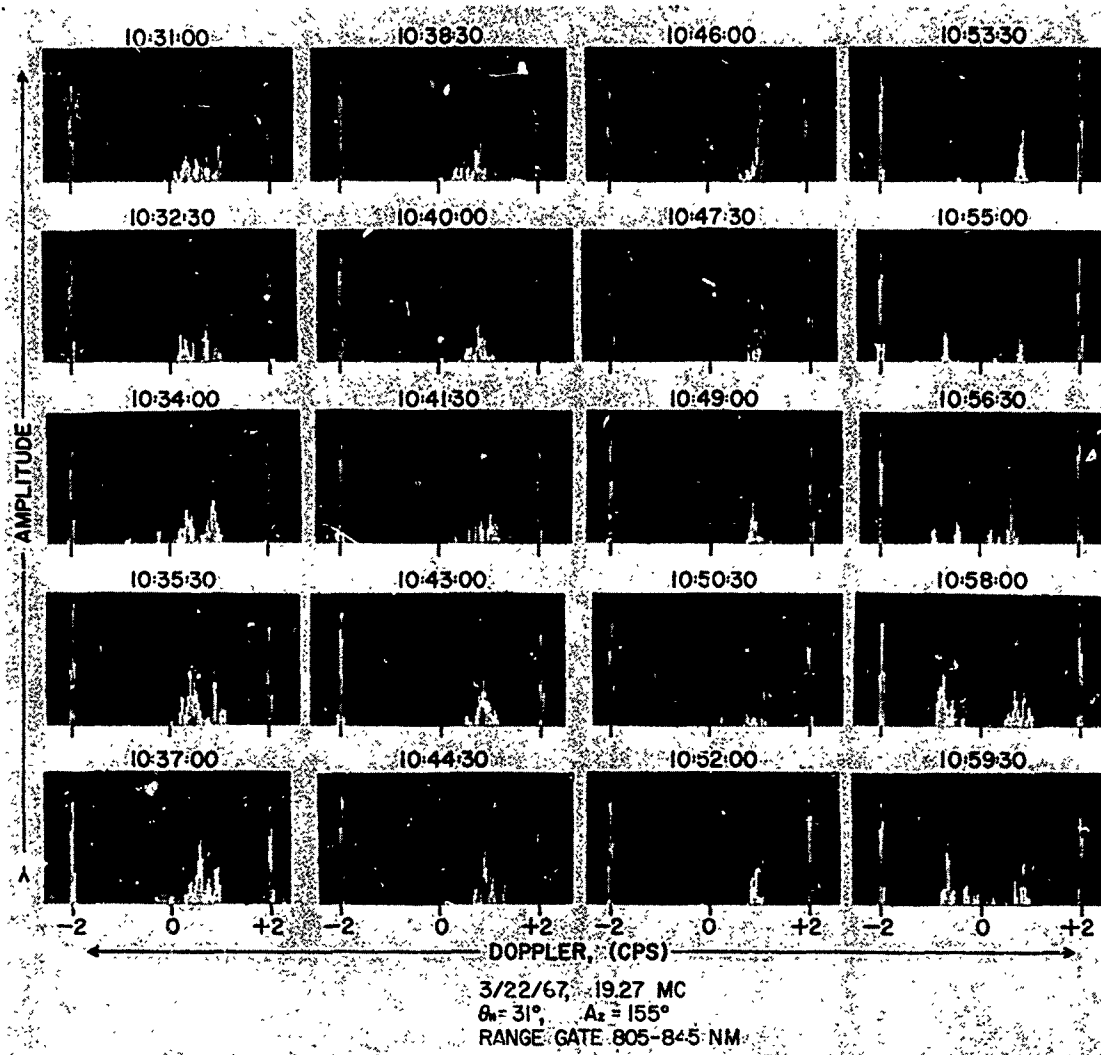

Fig. III-2 - Backscatter spectrum at 90-second intervals,
 19.27 Mc. Calibration at ± 2 c/s.

SECRET

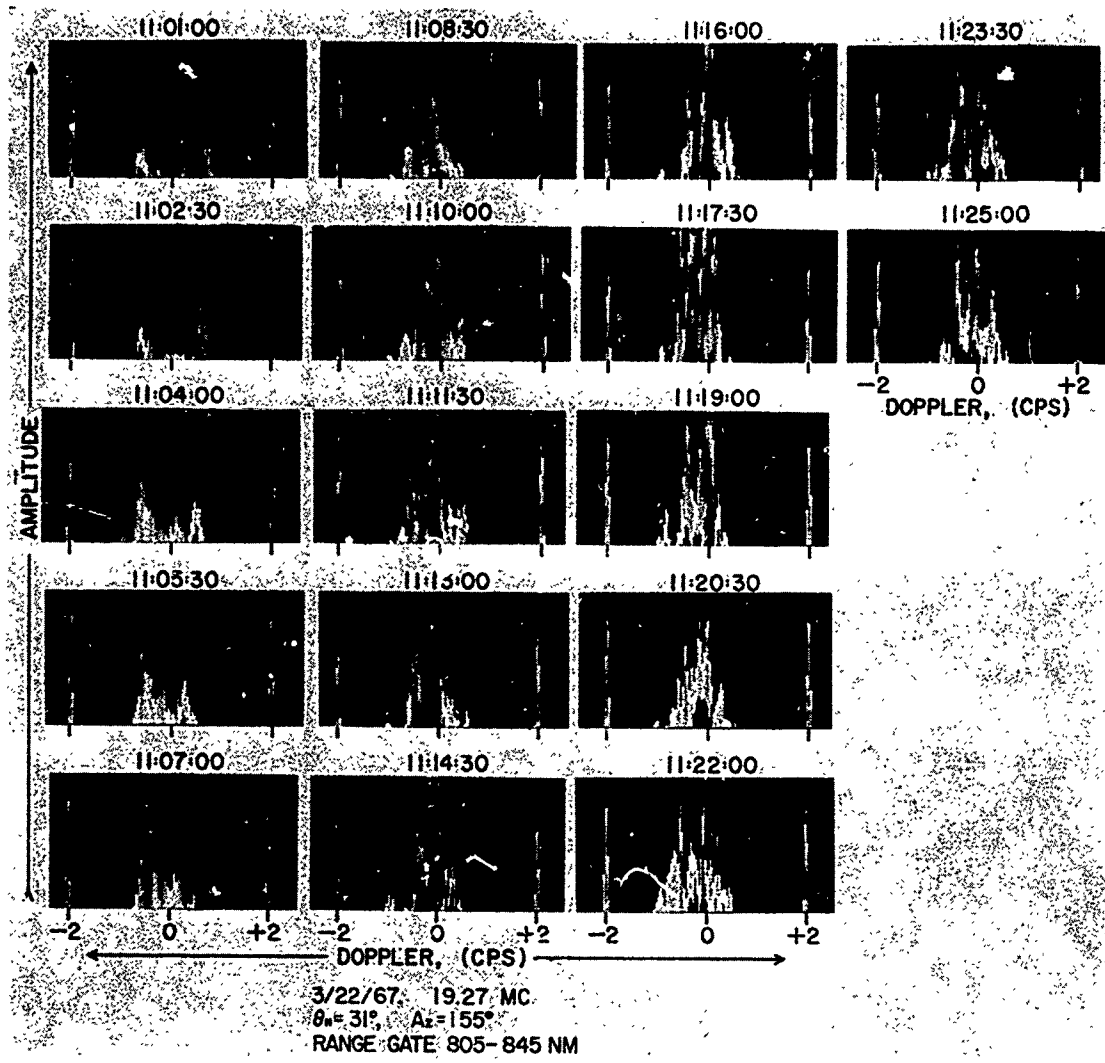

Fig. III-3 - Backscatter spectrum continued

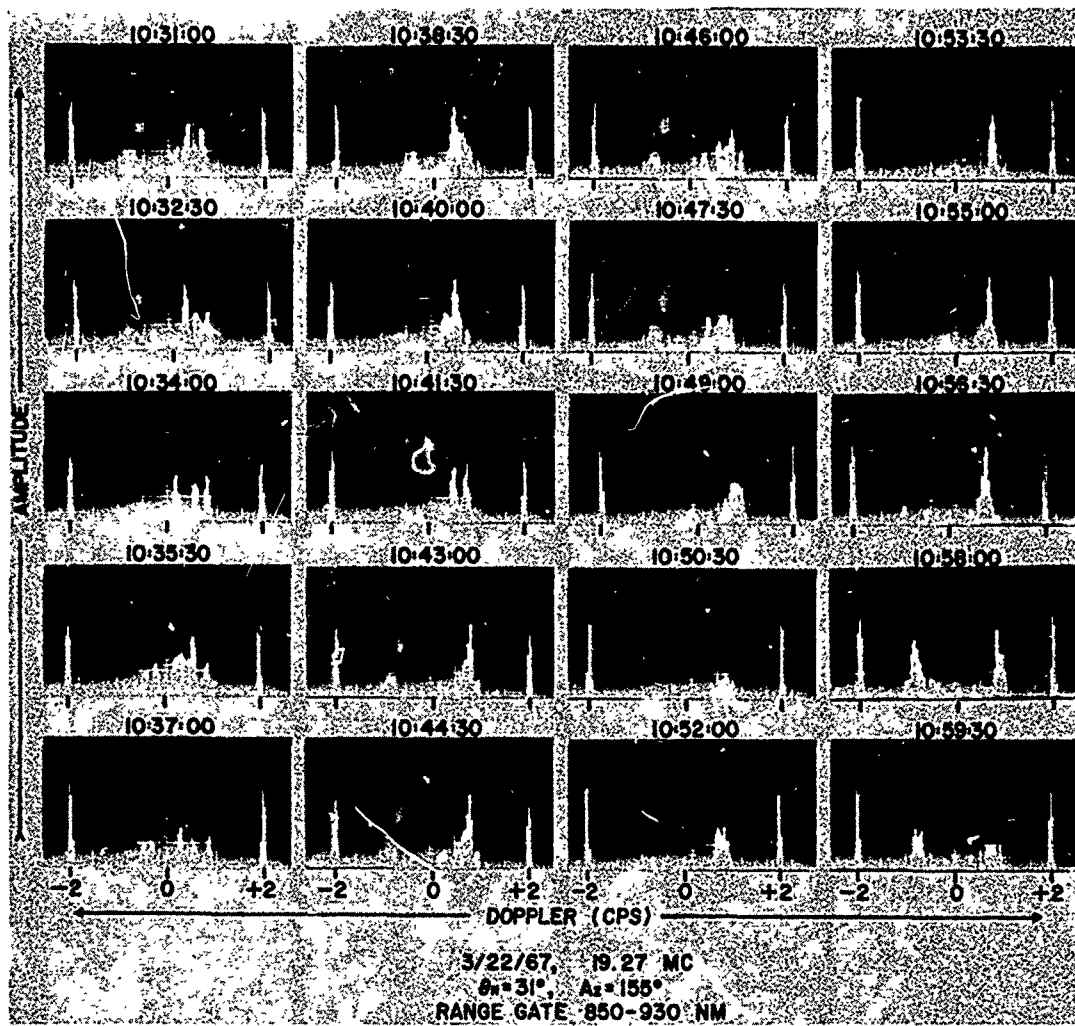

Fig. III-4 - Backscatter spectrum continued

SECRET

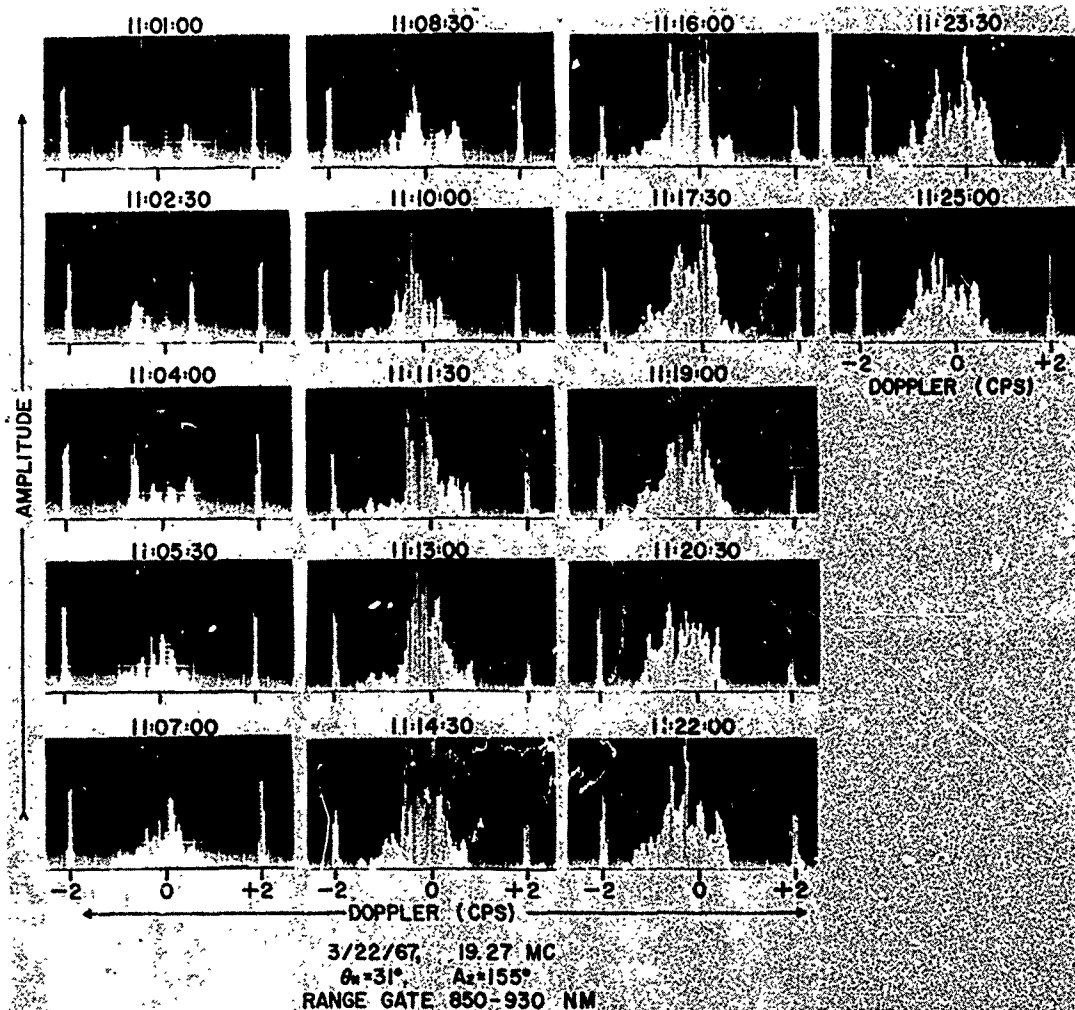

Fig. III-5 - Backscatter spectrum continued

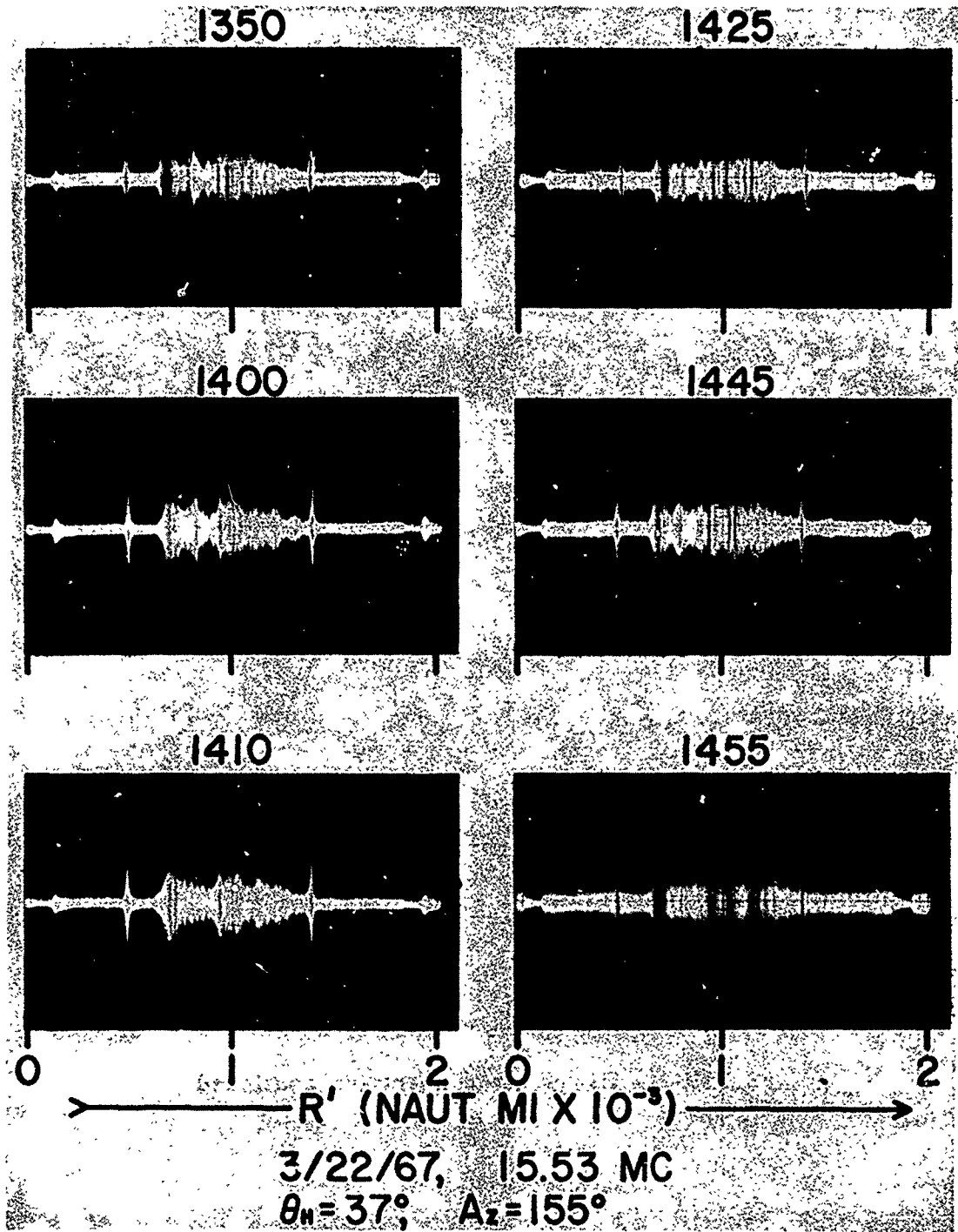

Fig. III-6 - Backscatter amplitude versus range at 15.53 Mc

SECRET

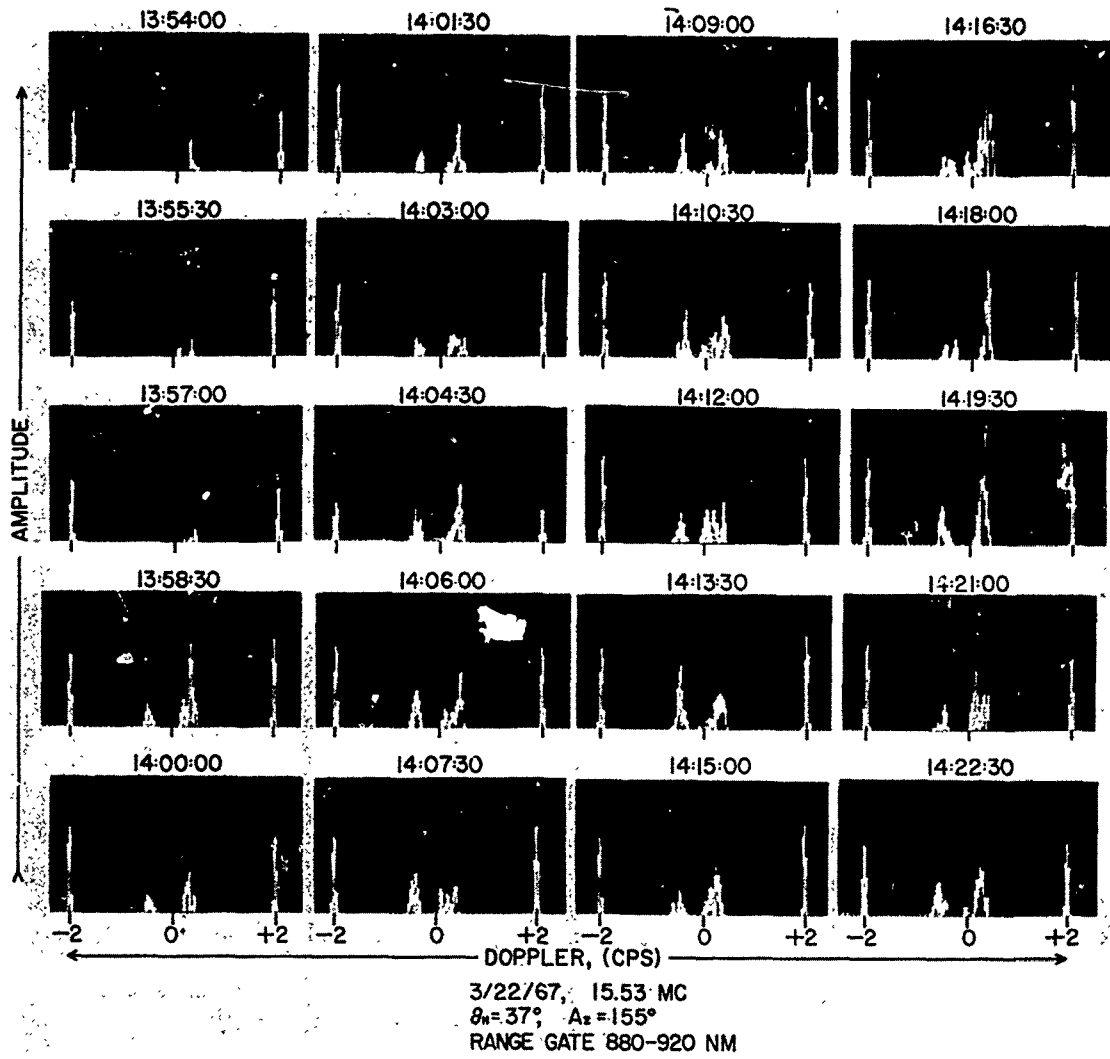

Fig. III-7 - Backscatter spectrum at 90-second intervals
15.53 Mc. Calibration at ± 2 c/s.

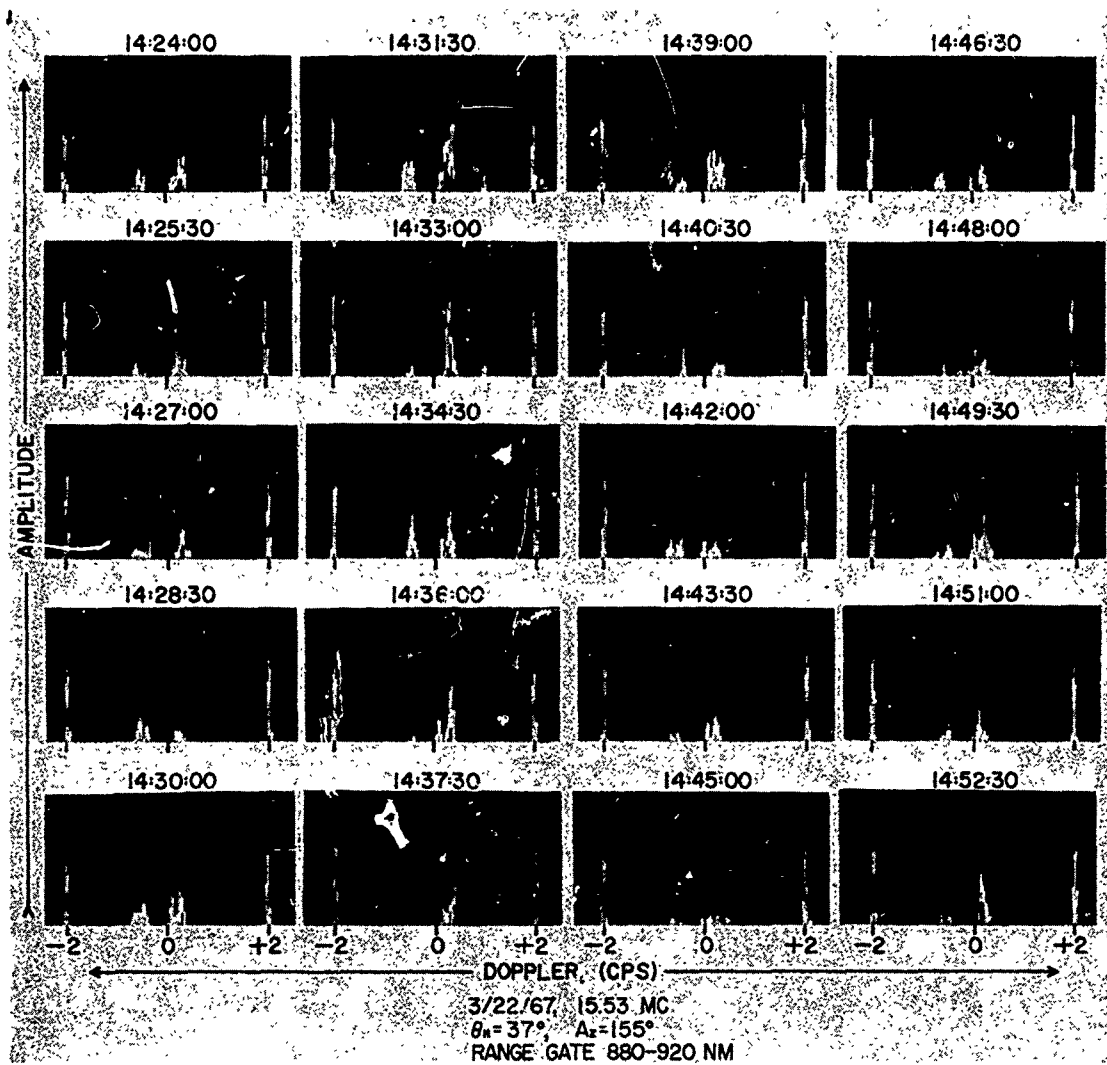

Fig. III-8 - Backscatter spectrum continued

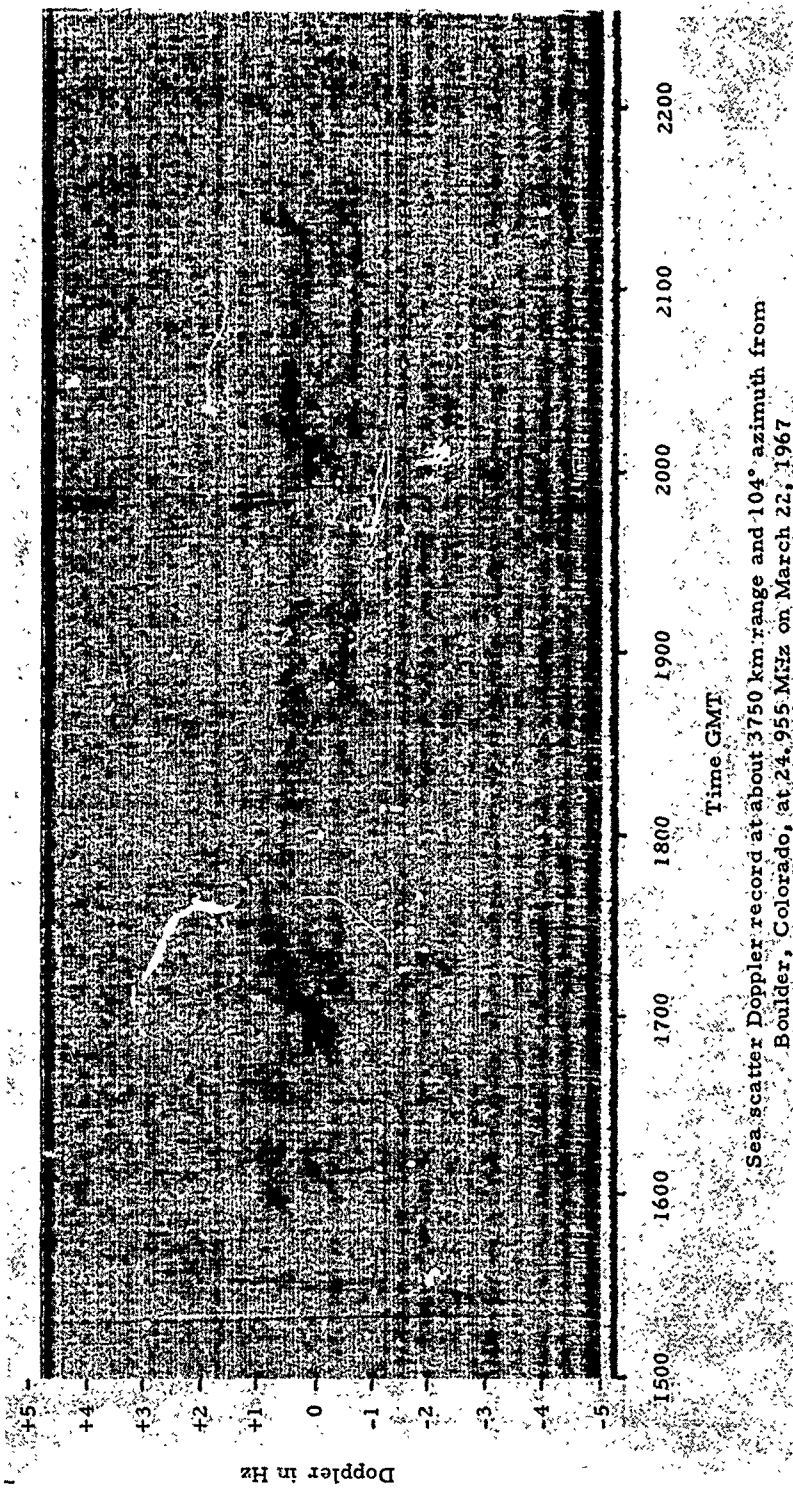

Fig. III-9 - Sea scatter spectrum as viewed from Boulder, Colorado

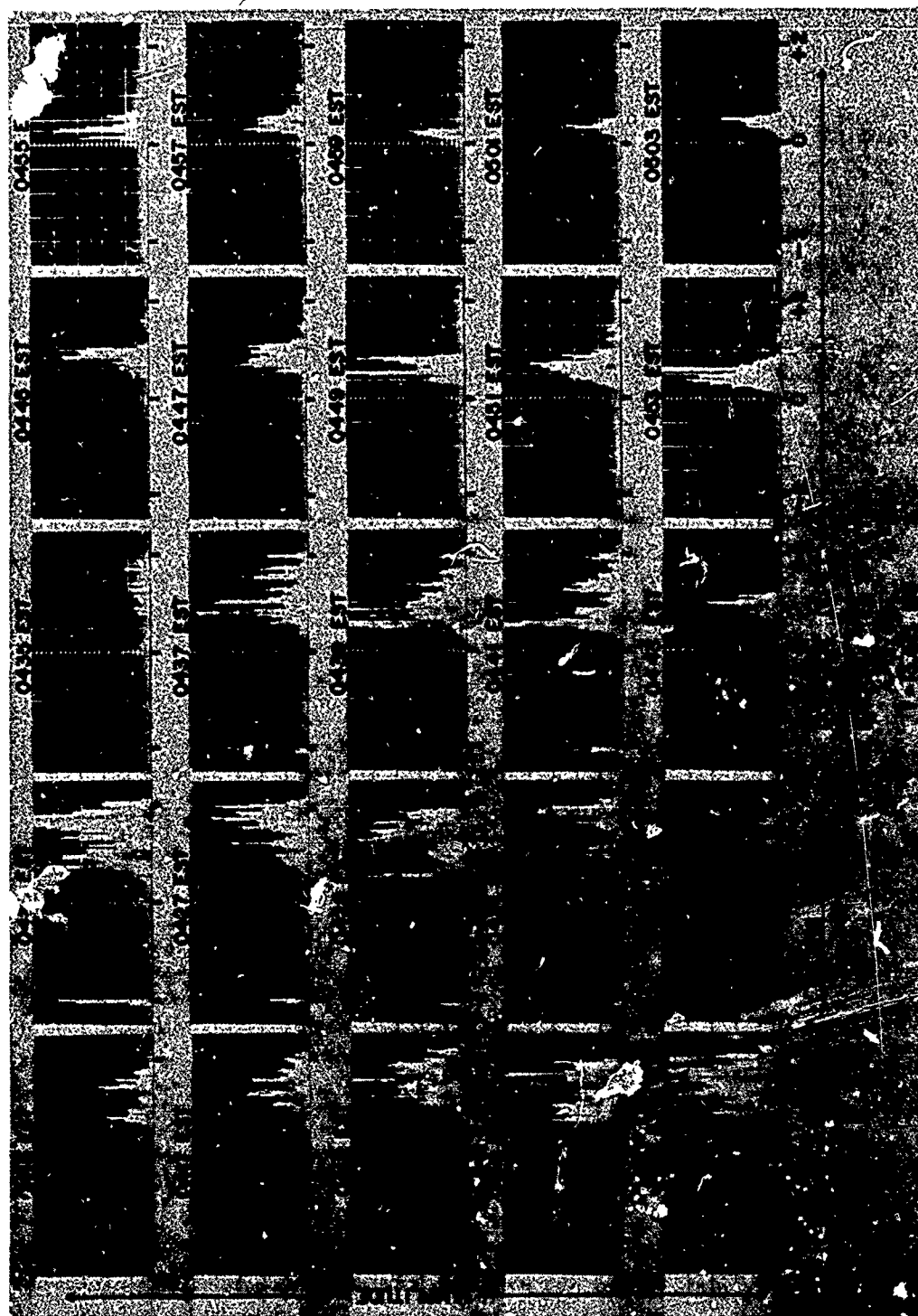

Fig. III-10 - Backscatter spectrum during sunrise

SECRET

DISCUSSION

The noise/interference distributions collected on a 5 kc channel basis give examples of what an HF radar must work against. These descriptions are not adequate for building a noise model for a coherent pulse doppler radar but should do well for a random frequency choice system with no coherent processing time. The absence of an adequate noise/interference description directly imposes a serious limitation on the ability to predict radar performance.

The frequency analyses of broadcast signals, the earth echo, and aircraft target indicate that at least part of the time there may be promise for detection and tracking of slow targets. To define slow, dopplers between a few tenths to a cycle per second are meant. The proportion of time that the capability might be available is estimated to be appreciable if conditions are chosen such that just one mode provides illumination. There is one unknown that could disqualify the above statement; all work has been done with a frequency analyzer of no better than 30 dB dynamic range. The detection of small, slow targets is contingent upon the backscatter spectra having tight low level skirts.

SECRET

SECRET

REFERENCES

Headrick, J.M., Zettle, E.N., Lucas, D.L., "High-Frequency Sky-Wave Radar Performance," NRL Report 6568, (Secret Report, Unclassified Title), June 1, 1967.

Headrick, W.C. and Ward, E.W., "High Frequency Channel Occupancy," Unofficial NRL Report with limited distribution (Unclassified) April 14, 1966.

Davis, J.R., Thomason, J.F., Hudnall, J.M., Boyd, F.E., and Utley, F.H., "The Spectral Characteristics and Temporal Behavior of HF Radar Echoes from Over-the-Horizon Aircraft Targets," NRL Report 6371 (Secret Report, Unclassified Title), Nov. 18, 1965.

Headrick, J.M., Headrick, W.C., Ahearn, J.L., and Ward, E.W., "Earth Backscatter Character at HF," Proceedings of the ARPA Meeting at SRI (Secret Report, Unclassified Title), July 7-8, 1965.

Headrick, J.M., Headrick, W.C., Ward, E.W., and Ahearn, J.L., "Spectrum and Amplitude of Earth Backscatter at HF," Proceedings of the ARPA Meeting at Boulder, Colorado (Secret Report, Unclassified Title), June 1-2, 1966.

SECRET

SECRET

Security Classification		
DOCUMENT CONTROL DATA - R & D		
<i>(Security classification of title, body of abstract and indexing annotation must be entered when the overall report is classified)</i>		
1 ORIGINATING ACTIVITY (Corporate author)	2a. REPORT SECURITY CLASSIFICATION	
Naval Research Laboratory Washington, D.C. 20390	Secret	
	2b. GROUP	
	3	
3 REPORT TITLE		
SOME SKYWAVE RADAR CONSTRAINTS (U)		
4 DESCRIPTIVE NOTES (Type of report and inclusive dates)		
Interim report on the problem.		
5 AUTHOR(S) (First name, middle initial, last name)		
J.L. Ahearn, W.C. Headrick, J.M. Headrick, and R.W. Ward		
6. REPORT DATE	7a. TOTAL NO. OF PAGES	7b. NO OF REFS
October 1967	58	5
8a. CONTRACT OR GRANT NO	8b. ORIGINATOR'S REPORT NUMBER(S)	
NRL Problem R02-23F,G	NRL Memorandum Report 1811	
b. PROJECT NO	9b. OTHER REPORT NO(S) (Any other numbers that may be assigned this report)	
USAF MIPR F30602-67-C-0070 USAF MIPR F30602-67-C-0069, USAF MIPR 30602-64-3412, USAF MIPR 30602- 65-3677, ARPA Order No.160 amendment 6 Feb. 3, 1965		
10 DISTRIBUTION STATEMENT		
In addition to security requirements which apply to this document and must be met, it may be further distributed by the holder only with specific prior approval of Director, Naval Research Laboratory, Washington, D.C. 20390.		
11. SUPPLEMENTARY NOTES	12 SPONSORING MILITARY ACTIVITY	
	USAF (RADC, Griffiss AFB, New York)	
13 ABSTRACT		
[SECRET]		
Sky wave radar performance and method of operation are limited by other users of the hf band and by variability of the propagation medium. Examples of measured noise and interference background show features of this constraint; indications are that any pulse system must work against an interference background greater than that due atmospheric or galactic noise and that the wider the bandwidth the higher the interference level. Signal processing time and target speed discrimination possibilities are studied by frequency analysis of earth backscatter, aircraft echoes, and one way transmissions; effective processing times can be in excess of 10 seconds and tests suggest that part of the time targets with relative speeds as low as 10 knots may be detectable using large dynamic range MTI methods.		

DD FORM 1473 (PAGE 1)
1 NOV 65

S/N 0101-807-6801

55

SECRET
Security Classification

SECRET

Security Classification

14 KEY WORDS	LINK A		LINK B		LINK C	
	ROLE	WT	ROLE	WT	ROLE	WT
Skywave radar constraints HF ionospheric radar Signal processing technique Spectrum occupancy Target speed						

MEMORANDUM

20 February 1997

Subj: Document Declassification

Ref: (1) Code 5309 Memorandum of 29 Jan. 1997
(2) Distribution Statements for Technical Publications
NRL/PU/5230-95-293

Encl: (a) Code 5309 Memorandum of 29 Jan. 1997
(b) List of old Code 5320 Reports
(c) List of old Code 5320 Memorandum Reports

1. In Enclosure (a) it was recommended that the following reports be declassified, four reports have been added to the original list:

Formal: 5589, 5811, 5824, 5825, 5849, 5862, 5875, 5881, 5903, 5962, 6015, 6079, 6148, 6198, 6272, 6371, 6476, 6479, 6485, 6507, 6508, 6568, 6590, 6611, 6731, 6866, 7044, 7051, 7059, 7350, 7428, 7500, 7638, 7655. Add 7684, 7692.

Memo: 1251, 1287, 1316, 1422, [redacted], 1500, 1527, 1537, 1540, 1567, 1637, 1647, 1727, 1758, 1787, 1789, 1790, 1811, 1817, 1823, 1885, 1939, 1981, 2135, 2624, 2701, 2645, 2721, 2722, 2723, 2766. Add 2265, 2715.

The recommended distribution statement for the these reports is: **Approved for public release; distribution is unlimited.**

2. The above reports are included in the listings of enclosures (b) and (c) and were selected because of familiarity with the contents. The rest of these documents very likely should receive the same treatment.

J. M. Headrick
J. M. Headrick
Code 5309

Copy: Code 1221 — *CR OK 7/1/97*
Code 5300
Code 5320
Code 5324