

UNCLASSIFIED

AD NUMBER

AD391696

CLASSIFICATION CHANGES

TO: unclassified

FROM: confidential

LIMITATION CHANGES

TO:
Approved for public release, distribution
unlimited

FROM:
Controlling DoD Organization: Assistant
Chief of Staff for Force Development
[Army], Washington, DC 20310.

AUTHORITY

30 May 1978 per DoDD 5200.10 document
marking; Adjutant General's Office [Army]
ltr dtd 29 Apr 1980

THIS PAGE IS UNCLASSIFIED

AD391696

15 May 66

CONFIDENTIAL

6 LESSONS LEARNED
HEADQUARTERS
145TH AVIATION
BATTALION

12 322 p.

HEADQUARTERS
145TH AVIATION BATTALION
APO San Francisco 96227

15 May 1966

AVAW-FC

SUBJECT: Operational Report on Lessons Learned Ending 30 April 1966.
(Report Control Symbol CSGPO-28 (RI))

"This document contains information affecting the National
Defense of the United States within the meaning of the
Espionage Laws, Title 18, U. S. Code, Sections 793 and 794.
Its transmission or the revelation of its contents in any
manner to an unauthorized person is prohibited by law."

TO: See Distribution

9 Operational rept. for period ending 30 Apr 66.

SECTION I: (C) UNIT ORGANIZATIONAL STRUCTURE AND OPERATIONAL STATISTICS.

A. (U) Reporting period is from 1 January through 30 April 1966.
and is submitted in accordance with AR 525-24, 29 October 1959 and USARV
Regulation 870-1, changes 1 and 2. Activities of subordinate units are
included as a section of this report.

B. (C) MISSION: 18 OACSFOR

AUG 12 1968

To augment, within the rules of engagement, the aviation support
capability available to II Field Forces Victor and the Republic of
Vietnam Forces operating within the III ARVN Corps Tactical Zone.

c. (C) ORGANIZATIONAL STRUCTURE: 19 OT-RD-660023

1. The 145th Aviation Battalion was reorganized in accordance
with General Order Number 28, Headquarters United States Army, Pacific,
dated 2 February 1966, with a reorganization effective date of 10 February
1966. The Battalion is composed of the Headquarters and Headquarters
Company, five aviation companies (three airmobile light companies, one
armed helicopter company and one fixed wing aerial surveillance company,
light) and supporting maintenance, medical, signal avionics and pathfinder
detachments.

2. The three Airmobile Light Aviation Companies (68th, 118th
and A/501st) are organized under the provisions of TOE 1-77E and augmented
by USARPAC General Order 262-65. Each AML Aviation Company either has
its own or shares with another company the attached maintenance,
medical and signal detachments. The companies consist of two airlift
platoons (16 UH-1D troop carriers), one armed platoon (8 UH-1B armed
helicopters) and one maintenance helicopter (UH-1B). The armed helicopter
company (197th) is composed of twenty-four UH-1B armed helicopters and
one UH-1B maintenance helicopter. The fixed wing aerial surveillance
company, light (74th) is organized under the provisions of 1-7D and
has twenty-five O-1F and O-1D aircraft authorized.

FILE COPY

FOR OT RD
660023

003 650

1
DOWNGRADED AT 3 YEAR INTERVALS;
Declassified after 12 years
DOD DIR 5200.10

CONFIDENTIAL

Best Available Copy

SECURITY

MARKING

The classified or limited status of this report applies to each page, unless otherwise marked.

Separate page printouts MUST be marked accordingly.

THIS DOCUMENT CONTAINS INFORMATION AFFECTING THE NATIONAL DEFENSE OF THE UNITED STATES WITHIN THE MEANING OF THE ESPIONAGE LAWS, TITLE 18, U.S.C., SECTIONS 793 AND 794. THE TRANSMISSION OR THE REVELATION OF ITS CONTENTS IN ANY MANNER TO AN UNAUTHORIZED PERSON IS PROHIBITED BY LAW.

NOTICE: When government or other drawings, specifications or other data are used for any purpose other than in connection with a definitely related government procurement operation, the U. S. Government thereby incurs no responsibility, nor any obligation whatsoever; and the fact that the Government may have formulated, furnished, or in any way supplied the said drawings, specifications, or other data is not to be regarded by implication or otherwise as in any manner licensing the holder or any other person or corporation, or conveying any rights or permission to manufacture, use or sell any patented invention that may in any way be related thereto.

CONFIDENTIAL

3. The aviation assets of this Battalion are allocated daily through the Army Aviation Element (AAE) of II Field Forces Victor Tactical Operations Center to support III (ARVN) Corps, and II Field Forces which consist of the 1st (US) Infantry Division, 25th (US) Infantry Division and the 173rd Airborne Brigade. This Battalion frequently reinforces other aviation battalions of the 12th Aviation Group, as this battalion is reinforced from other elements when the lift requirements for an operation are beyond the organic means. This Battalion has also reinforced the aviation requirements of the IV Corps and II Corps tactical zone.

D. (C) TYPE AND NUMBER OF AIRCRAFT ASSIGNED TO THE 145TH AVIATION BATTALION:

<u>TYPE</u>	<u>NUMBER</u>
UH-1B	5
UH-1B (A)	48
UH-1D	48
O-1F	22
U-6A	1

E. (C) OPERATIONAL STATISTICS FOR THIS PERIOD:

1. Number of aircraft hours flown by the Battalion in support of III ARVN Corps aviation requirements.

<u>UNIT</u>	<u>MONTHS</u>				<u>TOTAL</u>
	January	February	March	April	
68th Avn Co (AML)	1769.0	2087.0	2188.0	1948.0	7992.0
74th Avn Co (ASL)	1726.0	2098.0	2692.0	254.0	9056.0
118th Avn Co (AML)	1700.0	1673.0	2179.0	2167.0	7919.0
120th Avn Co (AML)	1426.0	1421.0	* N/A	* N/A	2847.0
197th Avn Co (armed)	1103.0	1474.0	1565.0	1573.0	5715.0
A/501st Avn Bn (AML)	1693.0	1625.0	1871.0	1595.0	6784.0
6th Airlift Plat	<u>464.0</u>	<u>511.0</u>	<u>* N/A</u>	<u>* N/A</u>	<u>975.0</u>
TOTAL	9881.0	11,089.0	10,495.0	9823.0	41,288

* Not Assigned

2. Total number of sorties flown during this period: 73,802

3. Number of Battalion size operations conducted by the 145th Aviation Battalion during this period:

	<u>Combat Assaults</u>	<u>Extractions</u>	<u>Repositions</u>	<u>Total</u>
JANUARY	28	13	8	49
FEBRUARY	30	9	9	48
MARCH	25	11	6	42
APRIL	25	5	0	30
TOTAL	<u>108</u>	<u>38</u>	<u>23</u>	<u>169</u>

CONFIDENTIAL

CONFIDENTIAL

4. Number of troops and passengers airlifted:

	<u>JANUARY</u>	<u>FEBRUARY</u>	<u>MARCH</u>	<u>APRIL</u>
Troops	12,239	9,899	17,225	13,284
Passengers	28,206	25,152	24,161	24,798
Total	40,445	35,051	41,386	38,082

5. Number of Viet Cong personnel killed, and structures and sampans destroyed.

	<u>V.C (KBA)</u>	<u>STRUCTURES (Dest)</u>	<u>Sampans (Dest)</u>
JANUARY	63	114	61
FEBRUARY	104	285	82
MARCH	155	411	97
APRIL	97	197	51
TOTAL	419	1007	291

F. (U) NUMBER OF DAYS ENGAGED IN TRAINING AND COMBAT OPERATIONS DURING THE QUARTER: 120

CONFIDENTIAL

SECTION II: (C) PERSONNEL

CONFIDENTIAL

A. (C) STRENGTH BREAK DOWN

The following break down depicts the authorized personnel strength verses assigned strength in all units assigned to the 145th Aviation Battalion.

Headquarters and Headquarters Company

	<u>OFF</u>	<u>WO</u>	<u>EM</u>	<u>AGG</u>
Auth:	22	2	87	111
Assg:	26	4	91	121

68th Aviation Company (AML)

	<u>OFF</u>	<u>WO</u>	<u>EM</u>	<u>AGG</u>
68th Avn Co	Auth: 14	41	141	196
	Assg: 22	22	145	189
282nd Sig Det	Auth: 1	0	9	10
	Assg: 1	0	9	10
391st Trans Det	Auth: 1	1	70	72
	Assg: 1	1	71	73
430th Med Det	Auth: 1	0	8	9
	Assg: 2	0	6	8
Total	Auth: 17	42	228	287
	Assg: 26	23	232	281

118th Aviation Company (AML)

	<u>OFF</u>	<u>WO</u>	<u>EM</u>	<u>AGG</u>
118th Avn Co	Auth: 14	41	141	196
	Assg: 21	27	141	189
573rd Trans Det	Auth: 1	1	70	72
	Assg: 2	1	68	71
93rd Med Det	Auth: 1	0	8	9
	Assg: 1		10	11
198th Sig Det	Auth: 1	0	9	10
	Assg: 1	0	10	11
Total	Auth: 17	42	228	287
	Assg: 25	28	229	288

CONFIDENTIAL

CONFIDENTIAL

197th Aviation Company (Armed)

		<u>OFF</u>	<u>WO</u>	<u>EM</u>	<u>AGG</u>
197th Avn Co	Auth:	29	26	139	194
	Assg:	20	25	144	189
571st Trans Det	Auth:	1	1	70	72
	Assg:	1	1	66	68
774th Med Det	Auth:	1	0	9	10
	Assg:	1	0	9	10
Total	Auth:	31	27	218	276
	Assg:	22	26	219	267

A/501st Aviation Battalion (AML)

		<u>OFF</u>	<u>WO</u>	<u>EM</u>	<u>AGG</u>
A/501st Avn Bn	Auth:	14	41	141	196
	Assg:	22	24	124	170
94th Sig Det	Auth:	1	0	9	10
	Assg:	1	0	13	14
151st Trans Det	Auth:	1	1	70	72
	Assg:	2	0	79	81
Total	Auth:	16	42	220	278
	Assg:	25	24	216	265

74th Aviation Company (ASL)

		<u>OFF</u>	<u>WO</u>	<u>EM</u>	<u>AGG</u>
74th Avn Co	Auth:	41	1	82	124
	Assg:	31	4	98	133
320th Sig Det	Auth:	1	0	9	10
	Assg:	1	0	11	12
563rd Trans Det	Auth:	0	0	24	24
	Assg:	0	0	22	22
Total	Auth:	42	1	115	158
	Assg:	32	4	131	167

B. (U) AWARDS AND DECORATIONS:

1. During this reporting period the following types and number of awards were presented to members of the Battalion.

5
CONFIDENTIAL

<u>TYPE</u>	<u>NUMBER</u>
Silver Star	7
Legion of Merit	1
Distinguished Flying Cross	37
Soldiers Medal	1
Bronze Star "Valor"	11
Bronze Star "Meritorious Service"	23
Airmedal "Valor"	67
Air Medal	2301
Army Commendation "Valor"	15
Army Commendation "Meritorious Service"	43
Purple Heart	37
	<hr/>
Total	2543

2. Of special significance, is the fact that the 10,000th Air Medal presented by this Battalion since 1 January 1965 was received this quarter.

C. (U) PUBLIC INFORMATION OFFICE (PIO)

During the period 1 January through 30 April 1966 the Battalion PIO forwarded one feature story per day to higher headquarters involving major items of interest happening within the Battalion. Several of the news releases were disseminated to publication agencies in the United States. On each airmobile operation a member of the PIO staff was represented in order to gain information and pictures of the battalion in combat. A photo team from the Department of Army Signal Branch spent the month of April with the Battalion gaining first hand information, both still pictures and movies of the battalion activities.

D. (U) AVIATION SAFETY:

1. The 145th Aviation Battalion flew a total of 41,288 hours during this reporting period and experienced the following aircraft losses and/or mishaps.

Combat Losses	5
Major Accidents	13
Incidents	8
Forced Landings	4
Precautionary Landings	9

2. To date, the 145th Aviation Battalion rate is 29.9 per 100,000 flying hours as compared to the USARV rate of 27.9. (31 March 1966)

3. The following is a list of those personnel who were fatalities or injured as a result of hostile ground action or accidents:

	<u>OFF</u>	<u>MO</u>	<u>BM</u>
Fatalities	3	2	5
Injuries	4	1	3

4. Approximately 150 aviators participated in a test conducted within the Battalion involving the use of a new type combination "nape-end-chin" strap for the APH-5 helmet. The primary purpose of this device was to retain the flight helmet on the individual in case of an abrupt stop. The tests were very successful and the device proved adequate in its intended use.

E. (U) CHAPLAIN ACTIVITIES:

The activities of the Battalion chaplain are many and varied and because of the distances between unit locations much of his time is spent traveling to and from these various points. Due to the many request for services, it was impossible for him to conduct normal services and interviews on sundays; therefore, most of the weekly services were conducted at night at the termination of the work day. In spite of the hectic schedule the following activities wer perofrmed.

Chapel Services	70
Counselings	67
Interviews	188
Visits to Orphanages	19
Meetings and Briefings	17
Christian Faith Instruction	23

CONFIDENTIAL

SECTION III (C) INTELLIGENCE:

A. (C) During January and February there were two reports of ground to air missiles, trailing smoke, fired from suspected V.C. positions toward airborne helicopters. Airbursts were observed near the aircraft indicating the V.C may be using some type of surface to air missile.

B (C) The V.C. massed into regimental size units in the III ARVN Corps to attack Vo Xu on 27 February and again on 21 March 1966. An attack was also launched against the 1st (US) Infantry Division in early March and against the 173rd (US) Airborne Brigade in mid March. Both of these were conducted by regimental size units. The V.C. sustained heavy casualties in all four attacks and since that time have conducted only small unit operations.

C. (C) The V.C. have introduced 75 MM "pack" howitzers in the III ARVN Corps during the past four months.

D. (C) The V.C continue to fire at helicopters at every opportunity. This is verified by the fact that aircraft have been hit and/or destroyed in areas where little or no contact has been encountered between the friendly ground elements and V.C.

E. (U) The weather has been favorable for all airmobile operations except on two occasions. Early morning ground fog delayed both operations for a three hour duration.

8
CONFIDENTIAL

CONFIDENTIAL

SECTION IV (C) OPERATIONS

A. (C) CONCEPT OF OPERATIONS:

1. The aviation tasks performed by this Battalion are varied and range from multi-ground combat battalion airmobile assaults and extractions, in which all elements operate as a battalion team, to single aircraft missions of observation, courier runs, pigs and rice lifts, and all manner of administrative and logistical missions.

2. Nightly, "Lightening Bug" missions are flown by the armed helicopter company exacting a significant Viet Cong kill and destruction of sampans and other enemy shipping.

3. Gunship teams daily provide on station firepower to road convoys, conduct strikes against enemy emplacements, installations and shipping. They are also employed around the clock as an immediate (5 minute) alert for the security of the Bien Hoa Airbase complex (Dong Nai Sensitive Section). Gunships have been effective in breaking V.C. attacks, ambushes, and are a significant factor in the security of U.S. and ARVN installations from attack.

4. The Battalion has been directed by MACV, through II Field Forces Victor, to conduct several special missions involving the development of special tactics and techniques. Of particular interest is "Operation Market Time". This is a joint operation involving the U.S. Navy and U.S. Army Aviation. It was initiated in early March and will continue for an indefinite period of time. The primary mission is to conduct off shore patrols and surveillance in order to enforce curfews and prevent Viet Cong infiltration, movement, and resupply along the Delta estuary coast and across the major rivers of the Mekong Delta and Rung Sat Special Zone (RSSZ). The armed helicopters in support conduct their flights from off-shore landing crafts and support river patrol craft and forces ashore with fire support as required. To properly support this operation, the aviation assets of all of the units within the Battalion have been used. By doing this, all assigned units gain an insight on such operations and it does not degrade the capabilities of any one company. Other MACV directed special missions include Mha Be Tank Farm fire team cover, Rung Sat Special Zone (RSSZ) continuous overhead river channel cover and Capital Military Region (CMR) 5 minute stand-by fire team coverage.

5. During the month of February the 145th Aviation Battalion Headquarters displaced from its location in Saigon to Bien Hoa, where the new Battalion Headquarters is established. During this transition period the Battalion continued to conduct airmobile operations in support of III ARVN Corps tactical and administrative requirements. During the months of February and March the following units were either assigned to or released from battalion control.

DATE

UNIT/ASSIGNMENT

10 February 1966

Augmentation of Pathfinder Detachment, C.O. 28, dated 2 Feb 1966.

CONFIDENTIAL

CONFIDENTIAL

15 March 1966

145th Aviation Battalion reverts to the control of II Field Forces Victor.

15 March 1966

120th Aviation Company and 6th Airlift Platoon released from Battalion control.

12 March 1966

774th Med Detachment attached to 197th Aviation Company.

6. The aviation assets of the Battalion are directly controlled by II Field Forces Victor. Daily, II Field Forces Victor allocates a certain number of aircraft to III ARVN Corps in support of its administrative and tactical requirements. The remainder of the aviation assets are then used to support either the 173rd (US) Airborne Brigade, 1st (US) or 25th (US) Infantry Divisions. Should the aviation requirements of III ARVN Corps exceed the assets allocated by II Field Forces Victor a decision for further aviation support will be made at that level of command. The assets of the Battalion are controlled by the Battalion Operations Center, which is responsible for determining the assignment of each mission and disseminating them to the companies of the Battalion. (Appendix A, (Battalion Operations Center SOP)).

7. Initial Battalion planning determines the number of troop carrier helicopters required for the conduct of an airmobile operation. Whenever the tactical requirement dictates the use of sixteen or more troop carriers, the operation will be coordinated, planned, and controlled by the Battalion. Fifteen troop carriers or less required for an operation will be coordinated and directed at Company level. A normal flight element for Battalion size operations consists of ten troop carriers (UH-1D) and four armed (UH-1B) helicopters. Other aircraft which comprise the airmobile task force are: command and control helicopter, a forward area maintenance recovery team, a standby recovery aircraft, a medical evacuation helicopter, five to eight armed helicopters and O-1F (Fixed Wing) aircraft to perform radio relay, weather advisory and surveillance.

B. (U) SIGNIFICANT BATTALION OPERATIONS

During this period the 145th Aviation Battalion coordinated, planned and conducted one hundred and sixty nine Battalion size operations (108 combat assaults, 38 extractions and 23 repositionings) and received and coordinated one hundred and ninety-two company size operations (164 combat assaults, 22 extractions and 6 repositionings) in support of the III ARVN Corps, 173rd (US) Airborne Brigade, 1st (US) and 25th (US) Infantry Divisions and II and IV Corps requirements. A sampling of seven battalion size tactical operations conducted are inserted as Inclosures 1 thru 7, Appendix B.

1. After Action Report, 145th Aviation Battalion Operation 2-66, dtd 2 January 1966.

2. After Action Report, 145th Aviation Battalion Operation 4-66, dtd 8 January 1966.

3. After Action Report, 145th Aviation Battalion Operation 15-66, dtd 2 March 1966.

4. After Action Report, 145th Aviation Battalion Operation 18-66 dtd, 9 March 1966.

5. After Action Report, 145th Aviation Battalion Operations 18-66 AA, 18-66 BB, and 18-66 CC (Extraction Phases) 210725, 211400, and 221125 March 1966.

6. After Action Report, 145th Aviation Battalion Operation 20-66, dtd 14 March 1966.

7. After Action Report, 145th Aviation Battalion Operation 22-66, dtd 5 April 1966.

C. (U) OTHER TACTICAL OPERATIONS

After Action Reports of other significant tactical operations are included in this report and inserted as Inclosures 8 thru 21 to Appendix E.

SECTION V (U) LOGISTICS

A. (U) III Corps ARVN airfields are primarily used as ARVN staging areas and as logistical bases of operation for the 145th Aviation Battalion. These airfields are geographically located throughout III ARVN Corps, so that any area of operation is within a 25-30 nautical mile radius of an airfield; the exception being the Rung Sat and a small area in the center of III ARVN Corps.

B. (U) Each airfield has a prestock of class III A and V which serves as normal operating stocks, and emergency stocks in support of III ARVN Corps contingency plans. The 145th Aviation Battalion does not have the capability to provide for its own logistical support (Class III A & V) while in support of ARVN forces, and relies upon use of these prestocks. Use of the prestocks for logistical support enables the battalion to respond rapidly and provide airlift support to the ARVN for both preplanned and rapid reaction type operations.

C. (U) Refueling is accomplished by the battalion at these airfields utilizing either 500 gallon bladders or 55 gallon drums and portable pumping equipment. The 500 gallon bladders are positioned in line and an entire flight element (ten to sixteen aircraft) can be refueled in a matter of minutes without shutting down. This method has proved extremely effective in refueling 4-6 flight elements on a continuous basis during battalion size multi-lift operations. Refueling can also be accomplished by loading 55 gallon drums on 2½ ton trucks and pumping fuel directly into the aircraft. Availability of trucks limit this type of operation and refueling time is lengthened by aircraft shutting down.

D. (U) Prestock levels are closely monitored by III ARVN Corp and the battalion since these prestocks represent the only real source of logistical support readily available to the battalion during airmobile operations with ARVN forces. The only time that III ARVN Corps and this battalion experience difficulties in maintaining the prestock level is when other US aviation units fail to coordinate with III ARVN Corps when they stage out of the ARVN airfields depleting the prestocks and do not immediately replenish them.

CONFIDENTIAL

SECTION VI (C) COMMUNICATIONS

A. (C) Fm frequency interference continues to be one of the biggest communications problems faced by the battalion. Prior to 1 April 1966 the companies of the battalion encountered some frequency interference from the ground units. On 1 April USARV Signal reallocated FM frequencies within the III CTZ. Instead of giving the aviation units relief from interference, they are sharing frequencies with other Aviation units. This creates very hazardous situations especially if both units are simultaneously involved in airmobile operations. This is a problem that requires command interest and emphasis at the highest level of command. It is imperative that each airmobile battalion and company be allocated a discreet FM frequency.

B. (C) Another communications problem encountered by the battalion during the last quarter was that of the shortage of Class A telephone numbers in the Bien Hoa area. Both the Bien Hoa local and the Bien Hoa long distance switchboards are filled to capacity. Only a minimum number of Class A numbers were made available to the battalion upon its arrival early in the quarter. This caused the battalion to have to install and continuously operate a 63 line battalion switchboard in order to have adequate telephone service. Since the TOE for the Communications Section does not provide enough switchboard operators for a 24 hour operation, a burden is placed upon those men of the section who have to work out of their MOS field while acting as switchboard operators. The shortage of Class A telephone numbers also has resulted in inadequate telephone service to Higher Headquarters (12th Aviation Group) in Saigon.

C. (C) Communications security discipline has improved greatly; however, security violations continue to occur, especially during airmobile operations. Common violations are, frequencies being transmitted in the clear, and brevity code words improperly used which enables ease of compromise. The overcrowded FM frequency spectrum makes it almost impossible to assign a new frequency when one is compromised.

D. (C) The existing telephone system in Vietnam is greatly overloaded. All calls should be official only and kept as brief as possible. Routine calls should also be timed to avoid the midmorning and midafternoon peak circuit loads. Routine messages should be routed through the battalion courier as much as possible to help relieve the load of the telephone system.

E. (C) The battalion UHF frequency is the primary control frequency during airmobile operations. It is imperative that this frequency have a minimum amount of interference. There has been a significant improvement in the transmission of only essential matter, in a brief, concise manner. The number of stations that are required to be in the net during a large scale airmobile operation, demands constant command emphasis to maintain a high state of communications efficiency.

CONFIDENTIAL

SECTION VII: (U) CIVIL AFFAIRS

A. (U) During this reporting period, the Civil Affairs activities underwent a major reorganization and revitalization. On 26 February a full time S-5 was appointed to coordinate the Battalion's Civic Actions. Civic Affairs was emphasized at all echelons of command. The program was expanded in scope to encompass Community Relations, Orphanage Support, Refugee Assistance and MEDCAP II Activities. In addition, the Battalion coordinated all of its civic actions through the Government of Vietnam, thus satisfying the long term objectives of the program. Appendix D, ("Proposed Expansion of the Battalion Civic Action Program").

B. (U) A recapitulation of the Battalions contribution to the economic and social development of Vietnam is as follows:

1. Donations:

- a. Foodstuffs 60,255 pounds VC captured, relief supplies, Battalion resources.
- b. Clothing 2300 pounds, mostly received from supporters in United States.
- c. Money 143,327 \$VN (\$1400 Approx.) Used primarily for education.

2. Refugees evacuated by air elements ----- 1500.

3. Relief supplies transported ----- 52,700 pounds.

4. Conversational English classes held ----- 30 classes.

5. Held sick call at Leper Colony ----- Weekly.

6. Emergency medical evacuation ----- 18 Vietnamese civilians.

7. Assisted in 2 self help school construction projects.

8. Assisted Popular Forces in construction of dependents quarters.

9. Distributed approximately 1000 pounds of health and sanitation items to local orphanages along with projects at the orphanage to improve the sanitation.

SECTION VIII: (U) TRAINING

A. (U) There is a continuing training requirement for each unit of the Battalion in order to maintain a high state of readiness and professionalism. The rapid personnel turn over in units aggravated this requirement. Due to the heavy operational commitments, much of the prescribed training is performed in conjunction with operational requirements whenever possible.

B. (U) The battalion has continually been called upon by higher headquarters to provide in country orientation and standardization briefings and flight training for newly arriving aviation units in the Republic of Vietnam. These units have ranged in size from aviation battalion staff and aviator personnel to four and five man fire team elements receiving training on special equipment and tactical doctrine developed by the Battalion. Staff members of the 25th Aviation Battalion spent several days with the Battalion staff receiving guidance and observing the detailed planning required in order to properly support ARVN and US ground elements in their counterinsurgency effort.

C. (U) Battalion training memorandums provide the nucleus from which necessary training is conducted. The following subjects receive continuing emphasis on a quarterly basis.

1. Aviator Unit Standardization Training.
2. Night Airmobile Operations.
3. Instrument Training.
4. Decca Navigational Training.
5. Individual and Crew Served Weapons.
6. External Loads.
7. Driver Education.
8. Chemical, Biological and Radiological.
9. Gunner Training.
10. Code of Conduct.
11. Special Training.
 - a. In Country Orientation and Standardization for newly arriving aviation units.
 - b. Airborne Radar Tests to determine the "pin point" vector accuracy of special equipment.
12. Armament and New Weapons Concept Training.

a. Mortar Aerial Delivery System -- "MAD" (Appendix I, to Annex P to 145th Avn Bn SOP for Airmobile Operations, Appendix E).

b. Offensive and Suppressive Fire Techniques (Annex M to 145th Avn Bn SOP for Airmobile Operations, Appendix E).

c. Lightning Bug Training.

d. Starlight Scope Training.

e. Cluster Bomb Unit -- "CBU".

f. 20 mm Weapon System.

SECTION IX: (U) COMMAND AND LEADERSHIP

A. During the period, the Battalion command changed on 20 February due to the death of its former commander as a result of a helicopter accident. A change of commanders, even under normal circumstances, is somewhat traumatic to the unit; therefore, all efforts were directed to quickly grasping the reins and moulding the Battalion into an even more effective operational team. Some actions that were taken that assisted this effort were:

1. To apprise each member of the Battalion of the importance of Army aviation to the ground combat unit's ability to effectively operate, and the contribution being made by the Battalion to "Win in Vietnam".

2. To emphasize that the Battalion engages in combat daily with the enemy, during airmobile assaults and extractions, when conducting gunship strikes or engaging in the offensive fire technique. The damage inflicted on the enemy is publicized weekly as realistic evidence that the Battalion in fact is a Combat Aviation Battalion and that its pilots, gunners and crewmen are combat crewmen. As a display of this title a Bronze Battle Star was authorized to be worn on the aviator and crewmen wings, after having earned the fifth Air Medal.

3. To institute a publication, entitled "Commander's Combat Notes", as a medium for transmitting information that the Battalion Commander deems necessary to keep all members of the command informed. The routine note is a Weekly Summary of activities of the Battalion. Appendix F, (Inclosures 1 thru 22)

4. To increase efforts to locate the entire Battalion in one geographic location at Bien Hoa. The condition of having individual companies of the Battalion widely separated tended to preclude battalion cohesion. The 197th Aviation Company moved from Saigon to join the 118th and A/501st Aviation Companies at Bien Hoa. The Battalion Headquarters and Staff also moved to Bien Hoa. Since the 120th Aviation Company was under operational control of MACV and the fact that it would remain in Saigon, overtures were made to ask for its removal from the Battalion. On 15 March, the company was transferred to the control of 12th Aviation Group. Efforts are underway presently to move the 68th Aviation Company from Vung Tau to Bien Hoa. When this is accomplished, four of the five companies will be located at Bien Hoa. The fixed wing surveillance company will remain at Phu Loi. It is evident that a marked increase in the Battalion team attitude has already resulted, which is a contributor to unit effectiveness.

B. (U) Modification of NCO Promotion Board: The Enlisted Promotion Board, which was formerly composed of NCO's only, was changed to include the Battalion Executive Officer, two Company Executive Officers, the Sergeant Major, and one First Sergeant. The board, employing the newly introduced evaluation forms, Appendix G, has greatly improved the quality of NCO's promoted within the Battalion. Basing the promotion on a "best qualified" basis has also produced at unit level a desirable side-effect in that it places all eligible personnel in a competitive position and results in a greater determination and higher job performance by the individual.

SECTION X: (U) COMMANDERS RECOMMENDATIONS:

The mobility, fire power, observation and logistic support provided by Army Aviation units in Vietnam is spelling victory to ground combat elements. Frequently combat operations go or don't go, based on the availability of rotary wing airlift. The build up of Army Aviation has enabled even larger ground combat operations, ranging to great distances. The frequency and scale of airmobile assaults, conducted in a repetitious manner is forcing the Viet Cong to expose himself to our devastating firepower. The aircraft we have available are still not enough to satisfy all operational requirements. Every effort is made to husband these critical resources by analyzing each mission in order to establish priorities.

The demands on aircraft preclude any maintenance stand-down in this Battalion. Every flyable aircraft is appointed and except in rare instances assigned a task. It is a credit to the maintenance personnel of this Battalion to achieve the continuous high availability rate experienced thus far. This however, comes about only through strong leadership within the companies, and having people who have a sense of urgency about them. Couple these traits with the ability to scrounge parts throughout Vietnam (the underground supply system) and the aircraft remain flyable. The price will be paid for this high useage factor however, in early equipment wearout.

Since this Battalion is the primary supporter of aviation to the three ARVN Infantry Divisions, the ARVN Airborne Division, the separate Ranger Companies and CIDG troops of III (ARVN) Corps, some comments are appropriate relative their use of Army Aviation. In general, all ARVN elements are quickly adapted to the airmobile assault. The airmobile technique appears to make the ARVN soldier more aggressive and confident. Difficulty arises when planning and conducting airmobile operations with ARVN forces in coordinating VNAF airstrikes, as to timing and type of ordnance. Difficulty is often encountered in obtaining information and warning of friendly mortar and artillery fire while aircraft are operating in the area. These problem areas are analyzed and consultation with U.S. advisory personnel develop a solution to preclude recurrence. The ARVN forces compete with the U.S. ground forces for the use of the available Army Aviation resources. The priorities are established and resources allocated by II Field Forces Victor Tactical Operations Center.

The U.S. Tactical Air Support provided for the preparation of landing zones has been outstanding. The strikes are accurate, they begin at the designated time, and carry the type ordnance requested. The single problem encountered is the length of time required to prepare the landing zone. The procedure has evolved where a FAC directs each aircraft on each pass to a specific target. The time required to prepare the LZ has been 30 to 45 minutes, and this is too long. It has been determined from experience and from captured documents that the Viet Cong are very familiar with the pattern that has been set for LZ preparation and have ample time to move toward the LZ prepared to attack the assaulting forces. The Air Force delivery techniques must be modified to place more ordnance into the LZ area in a shorter time. Simultaneous, multiple aircraft delivery appears to be the solution. It is recognized that accuracy will be sacrificed; however, this is acceptable and is outweighed by the shock action and surprise achieved through mass delivery.

The Viet Cong are fanatics at recording everything that we do and then analyze the operation to develop countermeasures (Ref Cbt Cmdrs Note No. 5, Appendix F). They particularly attempt to detect patterns. We have set many patterns in the conduct of airmobile operations. We are attempting for every operation to vary our pattern within the allowable limits. There are certain aspects that can be varied but others can't. We vary the helicopter formations but we can't vary the angle of descent or speed to any appreciable degree when in its most vulnerable stage, those last few hundred meters before touchdown in the LZ known as the "dead man's zone". We also set a pattern by preparing only one LZ, thus pinpointing the exact location we will land. When possible we now prepare several logical LZ areas, as a deceptive measure, knowing we will land at only one. When the tactical situation permits we may not prepare a landing zone with tactical air or artillery and use only armed helicopters to strike three or four minutes in advance of the lead troop carrier. Occasionally, without Tac Air we use a heavy volume of artillery fire for a short duration and immediately land with gunships providing the last, discrete, protective fires. In summary: stereotyped procedures compromise operations. Deceptions, innovations, and unpredictable, unorthodox procedures are the keynotes to success.

Civic Action activities by companies of this battalion are perhaps equally rewarding to them as to the indigenous recipients. A degree of competition has been established between companies which displays pride in their accomplishments. The companies become possessive of their Civic Action projects which creates a sense of unit responsibility for a certain activity. There is an attitude of ever increasing and expanding these activities. At present, some of the activities border on geographic areas between secure and unsecure area. In these locations Civic Actions have the capability of touching Viet Cong oriented people who can be swayed over to the GVN.

The aircraft hits from enemy ground fire are increasing. The hits are also becoming more accurate and striking the pilot compartment. Several aircraft have been knocked down or damaged to preclude further flight. Several hits have been experienced at 2500 feet; however, the morale and attitude of the crews have not been affected by these hits.

Looking at the Army aviator of this Battalion as a whole, he is an outstanding product. He is essentially combat arms experienced and oriented, and recognizes the significance of Army Aviation in this war. He is aggressive, proud of what he does, and intimately associated with the ground combat soldier. In fact, a mutual respect has developed that no longer requires Army aviation to be sold. Its worth is demonstrated daily. The attitude that now prevails is "How can each task be accomplished more effectively with greater destruction to the enemy?"

In the endeavor to exploit the offensive capability of the helicopter this battalion has employed teargas dispensed from a helicopter in flight over a likely avenue of approach into a helicopter landing zone. A few minutes after this delivery, when the tear gas has time to settle to the ground and force Viet Cong out of their holes, 60-81mm mortar rounds were dropped in the same area from a helicopter. Ground troops reported three kills by body count and took four prisoners from the area. Experiments with dropping CBU's from a helicopter, and the firing of the 20mm cannons are also in progress.

The offensive fire procedures, developed by the Battalion (Annex M, 145th Avn Bn SOP for Airmobile Operations) have been used on numerous occasions with great success. During a quick reaction operation when this Battalion supported the 5th ARVN Division, this technique was used by flying all available helicopters, troop carrier and armed, over a designated area in the "Iron Triangle" to pursue by fire the reported location of the withdrawing Viet Cong. No tactical air was available for the operation and the target was too lucrative to pass-up. Ground elements were not sent into the area; therefore, the extent of damage inflicted on the Viet Cong could not be determined. If the awesome sight of the ground erupting under the helicopters from the fire of over 60 aircraft was any indication - damage was inevitable and extensive.

The pilot shortage in the unit periodically results in flyable aircraft not being manned. A recent check reveals that this occurred on 17 occasions within a 15 day period. When looking at the overall pilot strength the reason for this isn't evident. Each aircraft is flown with a pilot and co-pilot, except for infrequent administrative type missions. The crewchief then occupies the co-pilot seat. The problem arises in the requirement to have a qualified aircraft commander in each aircraft. This qualification is achieved only after having fulfilled certain requirements of training, apprenticeship and then having been checked by a standardization pilot. These qualifications can be lowered, however this would invite an increase in accidents. Many pilots of this Battalion fly over 120 hours each month. After 90 hours they are examined by a flight surgeon and further flight is authorized by the Battalion Commander. Unit Commander's carefully observe pilots after reaching the 90 hour level. A certain amount of the pilot shortage is attributed to the non-flying duties that must be performed by pilots. Non-rated officers can assume a number of these duties.

Additional emphasis must be given to the personnel management of critical and specialized officer skills, especially in the area of aircraft maintenance. The absence or shortage of qualified school trained Aircraft Maintenance Officers has necessitated critical positions to be filled by unskilled personnel or left vacant.

Present TO&E for Transportation Detachments (CHFM) and Service Platoons of Airmobile Companies authorize one Captain MOS 64823 and one Warrant Officer (rated) MOS 671C. These positions are now being filled by Majors and Captains and a limited number of Warrant Officers, depending on the availability of qualified aircraft maintenance trained personnel to fill required vacancies.

To sustain daily Airmobile Operations, Aircraft Maintenance must be kept at the highest level of proficiency and emphasis must be continued to obtain qualified maintenance supervisors. Therefore, validated replacements to fill programmed vacancies for maintenance positions by name, rank, and MOS should be disseminated down to Battalion level sufficiently far in advance to preclude unqualified personnel being required to fill the technical position of Aircraft Maintenance Officer (MOS 64823) or Aircraft Maintenance Technician (671C).

A certain amount of degradation of unit effectiveness resulted from the rotation of officers between units of the Battalion and from the infusion program with the 1st Cav Division in an attempt to relieve DROS humps. The company team then must be retrained, yet there is never an opportunity to stand-down to train this team as a whole, due to operational commitments.

Aerial photos are vital to planning airmobile operations and the Battalion does not have an organic aerial photographic section. Aerial photos must be requested through Field Forces Victor G-2 Air Section, which takes seven to fourteen days for processing. Since average planning time for an airmobile operation is 24 to 72 hours, most operations are conducted without aid of aerial photos. The assignment of an aerial photo section to the Aviation Battalion would provide timely and adequate photo coverage.

Each commander of this Battalion is being faced with an emerging two-headed monster. The one head is operational. It has the sense of urgency to get the tactical job accomplished. It is the offensive spirit and is combat oriented to exploit aviation to its limits in support of the man on the ground. The other head is somewhat smaller at present but appears to be perceptibly growing. It is the peacetime administrative head and demands that the proper format and procedure is equally important as combat. It contends that both can be accomplished without one degrading the other. This two-headed concept is best typified by the type of flying performed by the Battalion. Accident prevention and safety, naturally is always practiced as a part of flying. However, there is seldom even a fine line between an aircraft accident due to combat and non-combat. Since many of the missions performed are with single aircraft, the decision as to whether the combat head or the administrative head reigns usually falls on the shoulder of a young Warrant Officer or Junior Officer.

FLIGHT CORRIDORS

ITEM: Artillery Flight Corridor Clearance.

DISCUSSION: Prior to each Battalion size airmobile combat assault, coordinates depicting the center line of the proposed flight corridor are relayed to higher headquarters for proper clearance. However, on numerous occasions these corridors were not properly cleared, thus resulting in some operational delays and near misses. (Inclosure 3, Appendix B).

OBSERVATION: Forwarding flight corridor clearance requests to ALE, II Field Forces Victor has reduced many of the previous problems encountered.

MULTIPLE LANDING ZONES

ITEM: Combat Assaults into Multiple Landing Zones.

DISCUSSION: When conducting combat assaults into multiple landing zones coordination and control is very difficult. Also, the requirement for armed helicopter support is doubled or tripled in order to properly prepare the LZ(s). (Inclosure 1, Appendix B).

OBSERVATION: By utilizing the armed helicopter platoons from the AML companies to help prepare the LZ's, simultaneous preparation may be accomplished. The armed helicopters do not escort the troop carriers all the way back to the staging area, but release them and pick them up at the R.P.

CH-47 UTILIZATION

ITEM: Utilization of CH-47 helicopters in conjunction with UH-1D troop carriers on combat assaults and extractions.

DISCUSSION: When conducting combat operations it is not feasible to combine CH-47 helicopters and UH-1D troop carriers. Problem areas encountered are: (Inclosure 3, Appendix C)

1. Lack of proper communications
2. Maneuverability
3. Vulnerability
4. Complexity of operating system

OBSERVATION: The CH-47 helicopter is ideally suited for resupply missions, arty displacement and heavy cargo carry after the initial introduction of combat troops into the operational area. The repositioning of forces from one secure area to another by CH-47 is feasible and desirable.

TROOP REPOSITIONING

ITEM: Positioning troops near the operational area.

DISCUSSION: On numerous occasions the operational area was located a considerable distance (40-50 nm) from the staging area. Long turn arounds result between lifts, resulting in a higher risk for forces in the objective area, and prolongs the duration of the conduct of the air movement phase.

OBSERVATION: Whenever possible, troops should be repositioned to a forward intermediate staging area which will alleviate the lengthy turn about time, thereby achieving mass more quickly in the objective area, reducing risk and decreasing the time to accomplish the airmovement. If the intermediate staging area is a prepared area, the repositioning should be accomplished by fixed wing aircraft to conserve the more costly and critical helicopter.

LANDING ZONE SELECTION

ITEM: Requirements for Landing Zone Selection.

DISCUSSION: In many instances, the landing zones selected by the ground elements were not suitable for helicopter operations. Ground units are not cognizant of obstacle restrictions, space requirements, angles of approach and departure requirements. (Inclosure 5, Appendix C)

OBSERVATION: It is mandatory that the Air Mission Commander (or representative) and the Airmobile Force Commander jointly reconnoiter the proposed landing zone(s) in the same helicopter.

SPECIAL WEAPONS

ITEM: Utilization of Special Weapons for Landing Zone Preparation.

DISCUSSION: The Viet Cong are known to carefully analyze the patterns of our airmobile assaults in order to devise countermeasures. In order to preclude the stereotype landing zone preparation which so often precedes the introduction of combat troops into the operational area, innovations must be devised in order to gain surprise and deceive the enemy.

OBSERVATION: Special weapons and varied delivery techniques have been used in the landing zone prior to the introduction of combat troops. Their effectiveness has been demonstrated by achieving enemy kills. (Annexes N and P to 145th Aviation Battalion SOP for Airmobile Operations, Appendix E).

ARMED HELICOPTER PRESTRIKE

ITEM: Utilization of Armed Helicopters to conduct the LZ prestrike in place of Tac Air and Artillery.

DISCUSSION: In order to eliminate the previously set pattern of lengthy LZ preparation the technique should be varied in such a manner that a rapid, devastating prestrike be conducted within 30 seconds of the first flight elements arrival in the LZ. (Inclosure 8, Appendix C)

OBSERVATION: The short, rapid, devastating LZ preparation achieved maximum surprise and is recommended when the situation will permit.

WHITE PHOSPHOROUS

ITEM: Use of White Phosphorous for LZ Preparation.

DISCUSSION: During several landing zone preparations by Tactical Air and Artillery, white phosphorous (WP) was used. This is very effective ordnance against ground troops and causes many casualties; however, it also acts as a screening agent and severely hinders the forward visibility of the approaching helicopters.

OBSERVATION: White phosphorous should not be used when preparing an LZ for the introduction of an airmobile force.

LOCATION OF FRIENDLY FORCES

ITEM: Marking locations of forward elements of Friendly Forces.

DISCUSSION: During the conduct of airmobile assaults or extractions there is a constant requirement for the airborne command element to know the location of the forward elements of friendly forces in order to safely direct gunships, artillery or tactical air against enemy targets.

OBSERVATION: Training at company and battalion level must constantly emphasize techniques to use and responsiveness in marking locations.

GROUND TACTICAL PLANNING

ITEM: Dissemination of Ground Tactical Plan of Supported Unit.

DISCUSSION: Prior to conducting an airmobile assault it is necessary that all supporting units be thoroughly familiar with the aspects of the supported units ground tactical plan. This must be accomplished so that immediate responsive aviation support is available to the ground commander during and after the airmobile operation.

OBSERVATION: Overlays of the supported units TAOR, objectives, and direction of movement must be provided to aviation units in time to incorporate into aviation unit briefings.

OFFENSIVE FIRE

ITEM: Fire Power Capability of UH-1D and UH-1B Helicopters.

DISCUSSION: The offensive fire technique has been developed to strike known or suspected enemy locations, deny the enemy certain areas, and seal off possible escape routes. It is a technique which directs all available fire power of an airmobile task force into a specific location where enemy positions are known or suspected. The method of devastation is normally used as the departure route from a landing zone. (Annex M to 145th Avn Bn SOP for Airmobile Operations, Appendix E).

OBSERVATION: This technique has been very effective and has accounted for Viet Cong confirmed KBI.

STAGING AREAS

ITEM: Landing Zone Conditions During the "DRY" Season.

DISCUSSION: The prevalence of hazardous dusty conditions during the dry season make operations in and around the troop pick-up sites very dangerous. Additional precautions and safety measures must be taken to safeguard against mid-air collisions and incidents which may very easily occur in this condition. (Inclosure 3, Appendix B).

OBSERVATION: Additional personnel and equipment have been provided to prepare adequate landing and staging areas. Recently, two major staging areas have been improved sufficiently enough to reduce this problem.

CONVERGING FLIGHT ELEMENTS

ITEM: Converging of Flight Elements at the Intermediate Staging area.

DISCUSSION: In the interest of saving time and fuel it has been found that flight elements based at various locations are capable of flying directly to the intermediate staging area and linking up with the remainder of the airmobile force. By doing this, it has enabled early completion of the assigned mission. (Inclosure 11, Appendix C).

OBSERVATION: This technique has proven very successful on several occasions and demonstrates that an airmobile task force can be rapidly assembled in flight.

UNANNOUNCED ARTILLERY FIRE

ITEM: Unannounced Artillery and Mortar Fire along the Flight Routes.

DISCUSSION: Unannounced artillery and mortar fire in close proximity to previously cleared flight corridors is a continuous hazard to flight and causes delays in the scheduled air movement. Even though prior coordination has been affected, a positive means of communication must be continuous between the command and control helicopter and the artillery base firing into the area of influence. (Inclosure 4, Appendix B).

OBSERVATION: Positive command emphasis has been placed on this matter and two Aviation Artillery Coordination Centers (AACC) are in the process of being organized in III ARVN Corps.

POST EXTRACTION SUPPRESSION

ITEM: Suppressing the Pick Up Site after the Last Extraction.

DISCUSSION: After the last troops and equipment are lifted out of the pick up area during the extraction operation the armed helicopters providing overhead cover will expend their remaining ordnance in and around the extraction site. All avenues of approach are thoroughly covered in order to preclude immediate reoccupation by the Viet Cong. (Inclosure 5, Appendix B).

OBSERVATION: This technique has proven very effective and on one occasion Tac Air was directed on Viet Cong observed exiting the area after the armed helicopters had completed the suppressive firing pass.

LOGISTICAL PRESTOCK

ITEM: Logistical Prestock Points Strategically Located with III ARVN Corps.

DISCUSSION: To preclude the possibility of having to transport aviation fuel and ammunition to remote operational areas, various prestock points have been strategically located at ARVN installations throughout III ARVN Corps. Until recently, availability of aviation fuel and ammunition has been no problem; however, with the introduction of additional U.S. Army elements into III ARVN Corps, these prestock points are slowly being eliminated through misuse.

OBSERVATION: U.S. Aviation Forces, other than this Battalion, staging from III ARVN Corps airfields where prestock points are located must affect coordination with III ARVN Corps prior to their usage. Prestock should only be utilized as a last resort.

FM COMMUNICATIONS

ITEM: FM Radio Interference.

DISCUSSION: Due to the increased number of US elements in RVN it is virtually impossible to communicate on FM frequencies without being blocked out by either RVN or U.S. At the present time units are having to share frequencies due to the limited FM frequencies available.

OBSERVATION: Each airmobile battalion and company must have its own tactical frequency whether it be FM or VHF.

STANDING OPERATING PROCEDURE
NO. 6

145th Aviation Battalion
Bien Hoa, RVN
15 March 1966

BATTALION OPERATIONS CENTER

1. GENERAL:

a. References: References and guidance for Battalion Operations Center activity are outlined in appropriate Army, MACV, USARV, 1st (US) Inf Div, III Corps, and 145th Aviation Battalion directives, regulations, circulars training memorandums and standing operating procedures.

b. Purpose: To establish policies and procedures which will facilitate the smooth and uninterrupted functioning of the Battalion Operations Center.

c. Mission: To receive and coordinate all tactical and administrative aviation support requirements disseminated to the Battalion by the Army Aviation Division of Field Force, Vietnam II or the 173rd Airborne Brigade and III ARVN Corps, supported Units.

d. Definitions and Abbreviations:

(1) Flyable Aircraft - Aircraft in a flying status, which do not meet the criteria of mission ready aircraft. Included in this category are aircraft which have mission essential equipment either removed or inoperable. Also included as flyable but not mission ready are those aircraft requiring test flights, operational checks, etc.

(2) Mission Ready Aircraft - Aircraft immediately available for mission deployment with all mission essential equipment installed and fully operational, including Crew.

(3) Aircraft Available for Commitment - The aircraft shown in a mission ready posture capable of being committed immediately in response to aviation requirements from higher headquarters. (Note - This does not include the Aviation Battalion Command and Control Aircraft, staff aircraft, maintenance aircraft and aircraft required by the companies to fulfill training requirements in order to maintain a high state of proficiency).

(4) Committed Aircraft - Those aircraft that are actively performing missions assigned by 12th Aviation Group AAD or III Corps.

(5) Air Alert- Those aircraft committed in support of higher headquarters will continually monitor Capital Center frequency and/or battalion control frequency in order to rapidly react to an immediate recall. or aircraft will be placed on station in the air to be responsive and cover a particular operation.

APPENDIX A

27

(6) Ramp Alert- Aircraft with all components fully operable, in a mission ready posture and an entire flight crew ready to react within 5 minutes.

(7) Villa Alert-Aviation Personnel in a mission ready posture and capable of reacting to any emergency within 30 minutes. Aircraft must be available and ready on the ramp.

(8) High Voltage-Indicates that an emergency exists in the III Corps Tactical Zone. Designated aircraft will terminate the assigned mission as rapidly as possible and proceed with maximum speed to the assigned area, refuel, arm, and line up by company element as indicated in the Battalion Air-mobile SOP.

(9) AAE- Army Aviation Element.

(10) AAD-Army Aviation Division.

(11) AALO-Army Aviation Liaison Officer.

(12) AAOS-Army Aviation Operations Center.

(13) BOC-Battalion Operations Center.

(14) COC-Combat Operations Center.

(15) DACO-Departure Airfield Control Officer

(16) DTOC-Division Tactical Operations Center

(17) OPREP- 5-Operational Report Number 5

(18) REDOPS-Unit Readiness Report

(19) TOC-Tactical Operations Center

2. ORGANIZATION: The Battalion Operations Center is staffed with seven personnel; the OIC (Assistant Division Aviation Officer (Major), three Duty Officers (Assistant Division Liaison Officers) (Captains), one Operations Coordinator (Sp-4), and three Division Liaison Team Sergeants.

3. DUTIES AND RESPONSIBILITIES:

a. OIC, BOC-The OIC, BOC is directly responsible to the Battalion S-3 for all matters pertaining to daily battalion aviation support requirements. The OIC, BOC is also the head of the Battalion Liaison Section. Duties of the OIC, BOC include:

(1) Supervising the daily mission scheduling and activities of the Duty Officer.

(2) Advising the 12th Aviation Group AAD and III Corps AAE of battalion assets and capabilities.

(3) Insuring the equal and consistent assignment of missions to subordinate units commensurate with the units capability and the prevailing tactical and operational situations.

(4) Supervising the preparation of all outgoing communications as required. (Reports, NOTAMS, explanatory directive, etc.).

(5) Coordinating battalion tactical operations with other mission requirements.

(6) Maintaining a current and thorough knowledge of aircraft requirements pertinent to 173rd Airborne Brigade, III Corps, 145th Avn Bn and other units as directed by FF-V II, AAD.

(7) Supervising the administrative performance of the Pathfinder Section (Provisional).

(8) Supervising the functions of the Operations Coordinator to insure the adequacy and preparedness of BOC administration and files.

(9) Updating all reports, report formats, and reporting procedures as required.

(10) Insuring the smooth, continuous operation of BOC around the clock.

(11) Advising the S-3 of current changes or requirements applicable to, and affecting the operations of, BOC.

b. Pathfinder Detachment Commander (Provisional): The pathfinder Detachment Commander (Provisional) works under the supervision of, and maintains close coordination with, the OIC, BOC. He is directly responsible to the S-3 for the performance of pathfinder operations but under the administrative supervision of the OIC, BOC for day to day routine operations. During the conduct of tactical operations, the Pathfinders Detachment will be employed as an integral part of the Battalion Command and Control Group. Duties of the Pathfinder Detachment Commander are:

(1) Advance Coordination with the S-3, 145th Avn Bn, to determine aircraft employment, staging and operational areas, elements to be airlifted and all specific information pertinent to the planned operation.

(2) Preparation of detailed staging diagrams.

(3) Liaison with a ground representative of the elements to be airlifted.

(4) Preparation of the staging area with lights, smoke, radio assistance and pathfinder personnel as required.

(5) Organization of troops in the loading zone.

(6) Advising the S-3 and Battalion flight elements of the tactical situation prevailing in unsecure field locations (extraction-staging sites), approach and departure routes, enemy information, weather and any other information about unforeseen contingencies which may develop.

(7) Maintaining pathfinder equipment in a high state of readiness and repair. (Annex L).

c. **BOC Duty Officer:** To provide continuous and expedient aviation support a Duty Officer is required to be on duty in the Battalion Operations Center twenty-four hours a day. In order to accomplish this, three (3) Duty Officers are utilized, each fulfilling a twenty-four hour duty tour commencing at 1200 hours daily. His duties are:

(1) Advising 12th Avn Gp AAD and AAE at III Corps of battalion capabilities (aircraft availability).

(2) Maintaining appropriate records and status daily as required.

(3) Accepting and consolidating operational reports from units within the battalion and preparing battalion reports for forwarding as required.

(4) Recording and assigning all missions received from the III Corps AAE, 173rd Airborne Brigade and AAD of FF#VII.

(5) Monitoring the progress of individual missions and the location of all battalion aircraft at all times.

(6) Initiating action on downed or missing aircraft.

(7) Maintain the S-3 Daily Staff Journal.

(8) Maintain BOC Situation Map of current ground operations, naval gunfire, downed aircraft locations, etc.

d. **Operations Coordinator:** The Operations Coordinator will:

(1) Prepare all reports and stencils and initiate distribution of required reports to higher headquarters.

(2) Keep all files up to date.

(3) Maintain flight records of rated Officers and Warrant Officers assigned to Headquarters, 145th Aviation Battalion.

(4) Maintain expendables and office equipment as required.

(5) Maintain all equipment received to the BOC Section.

(6) Assist the Duty Officer in office functions.

4. SUPPORT REQUEST CHANNELS: The 145th Aviation Battalion is assigned to 12th Aviation Group. However, the battalion assets will be committed in direct support of the III ARVN Corps and the 173rd Airborne Brigade. Should aviation requirements occur for units other than III ARVN Corps and the 173rd Airborne Brigade, 12th Aviation Group will establish priorities as directed by FF-VII.

a. 12th Aviation Group AAD: Should an aviation requirement exist in III ARVN Corps or the 173rd Airborne Brigades Tactical Area of Responsibility which is beyond the assets of the 145th Aviation Battalion, a request for additional aviation support will be forwarded to 12th Aviation Group AAD. The decision for the requested aviation support will be made by 12th Aviation Group AAD. Normally the 145th Aviation Battalion S-3 will coordinate the aviation requirements with the BOC Duty Officer.

b. III Corps Missions: Mission requests from the III Corps AAE are telephonically transmitted to BOC daily. The requests are for both the III ARVN Corps Divisions (5th, 10th and 25th) and the 173rd Airborne Brigade. They will be fulfilled with the available aircraft from the battalion providing 12th Aviation Group AAD does not have higher priority aviation requirements for the battalion. Should aviation requirements from both agencies exceed the available assets, 12th Aviation Group AAD will have priority over III Corps mission requests.

c. MACV Missions: The 145th Aviation Battalion does not fall under the operational control of MACV (AAOS). Should a requirement exist to fulfill a MACV request, the mission will be forwarded to 12th Aviation Group AAD who in turn will determine which aviation battalion will fulfill the mission.

d. 145th Aviation Battalion Missions: Aviation requirements of a tactical nature for the battalion will be planned, coordinated, conducted and controlled by the Air Mission Commander or his delegated representative. All requirements to support the 145th Aviation Battalion, (ie: training, staff, courier, etc.) will be fulfilled without jeopardizing III Corps or the 173rd Airborne Brigade aviation requests.

5. MISSION SCHEDULING:

a. Availability Forecast: Prior to 1430 hours daily, a forecasted report of aircraft availability for the following day will be rendered to BOC by the companies within the battalion. This forecast report in turn will be forwarded to 12th Aviation Group AAD and III Corps AAE prior to 1500 hours where it is used to plan the following days aviation requirements. All III Corps requests will be submitted to BOC by the III Corps AAE. Should the requirement exist to support 12th Aviation Group AAD commitments, this will take priority over III Corps requests. In order to properly distribute the missions to the individual Mission Sheets are utilized (Annex A and B).

b. Receiving and Assigning Missions: Mission requests from III Corps and 12th Aviation Group AAD will be recorded on the Master Mission Sheet. After receipt of these missions, they will be recorded by type aircraft and disseminated to the companies on the individual mission sheet (Annex B). After submission, the Master Mission Sheet and the individual mission sheets are placed in the appropriate binder and maintained for ready reference throughout the tour of duty. All changes to previously scheduled missions will be recorded on both the Master Mission Sheet and Individual Mission Sheet.

c. Recording and Filing Missions: Copies of the Master Mission Sheet will be prepared in duplicate and made available to the Battalion Commander and S-3 prior to 0830 hours daily. At the close of the day, the Master Mission Sheet and individual mission sheet work copies will be consolidated, filed and retained for a period of thirty days.

6. REPORTS:

a. Daily Staff Journal (DA Form 1594): The completed journal, which is the official record of actions and communications, will be submitted to S-3, 145th Avn Bn no later than 0830 hours daily. This report will reflect a twenty-four hour period from 0700 to 0700 daily. Upon completion of review this form is returned to BOC and placed under confidential cover for permanent retention. (Annex C).

b. 145th Aviation Battalion Aircraft Commitment Report (145th Avn Bn Form 4): The daily status of all assigned aircraft by unit and type in support of III ARVN Corps, 173rd Abn Bde, MACV and the 145th Avn Bn is shown on this report. It is the responsibility of the BOC Duty Officer to prepare this report prior to 0830 each morning. The report is confidential, marked accordingly, prepared in triplicate and distributed as follows:

(1) Original - Battalion Commander.

(2) Copy - Battalion S-3.

(3) Copy - File.

The file copy is retained in BOC for a period of thirty days after which it is destroyed. (Annex D).

c. OPREP-5 (Daily; Results and Highlights): A daily report submitted to agencies as indicated below. The report is a narrative of the previous day's aviation highlights. It details company sized or larger operations, etc. A negative report, if appropriate, is required. The text of the report is prepared by the OIC BOC by 0900 hours daily and forwarded to the S-3 for review and approval. (Annex E). After action has been taken by the S-3, the report is distributed as follows:

(1) Original - Commanding Officer, 12th Avn Grp (S-3) AVAM-SC

(2) Copy - Commanding General, USARV ATTN: AVAV

(3) Copy - Commanding General, FFV II ATTN: AAE-TOC

(4) Copy - S-3

(5) Copy - File

d. Sorries and Hours Flown in Support of Combat Operation (145th Avn Bn Form 8): Used whenever the 145th Avn Bn is involved in providing prolonged aviation support to either US or VN ground forces. Also implemented at the specific request of the S-3 to provide necessary documentation for the preparation of other related reports and statistics maintained by S-3. The required information contained in this report will be forwarded from the companies to BOC at the close of each day's flying activity. The BOC Duty Officer will record the information on 145th Avn Bn Form 8. This report will be attached to the BOC copy of the daily OPREP -5 and made available upon request. (Annex F).

e. OPREP-5 Report (Weekly): This is a comprehensive and detailed summary of all aviation activities from all units within the battalion which occurred in the space of one week. It is compiled every Thursday evening by the BOC Duty Officer who receives the necessary information from the individual units within the battalion. The report is broken down into four sections; two for fixed wing aircraft, one for rotary wing aircraft, and one which applies to both. Final preparation is completed the following morning and, after review by the S-3, the report is telephonically submitted to 12th Avn Grp (Annex G). Distribution of the report is as follows:

- (1) Original - 12th Grp (AAD)(Action)
- (2) Copy - III Corps (Info)
- (3) Copy - 145th Avn Bn S-3 (Info)
- (4) Copy - File (Info)

The file copy is retained for a period of one year.

f. 95-5 Checklist (145th Avn Bn Form 7): This report is required only when a unit of the battalion is placed in support of an operation the 145th Avn Bn is otherwise not supporting. The form provides the battalion headquarters with information regarding the number of aircraft involved, area of operations, unit to be supported, etc. It will be submitted by the unit involved as soon as the necessary information becomes available. (Annex H).

g. Downed Aircraft Report (USARV Form 195): All information contained on this report is telephoned to BOC by the unit involved. Upon receipt of this information it will be distributed to the agencies listed at the top of the form. (Annex I).

h. Unsatisfactory Mission Report (145th Avn Bn Form 5): If, during the conduct of an aviation support mission, it is felt that aircraft utilization was not proper, this form should be completed and forwarded to BOC within twenty-four hours of the misutilization incident. It is the aircraft (Mission) Commander's responsibility to file the report with his unit operations officer who will in turn forward it to BOC. The report will be forwarded by BOC to the S-3 for further action. (Annex J).

1. REDOPS Report: The REDOPS Report is a daily report required by CG, FF-VII. It provides FF-VII and higher headquarters with essential information necessary to exercise command and operational control. Essentially, the report reflects the operational readiness of a unit based upon three criteria; personnel, major items of authorized equipment on hand (aircraft), and major items of equipment operationally ready. A master copy of the report is maintained in BOC and at FF-VII COC. Since the report is a status-type report, changes by line item only are required. The companies will phone the changes to BOC by line number every evening prior to 2200 hours. The Duty Officer will record the changes on the master copy (on acetate) and relay the consolidated reports to FF-VII COC between 2300 hours and 0200 hours daily. In addition to recording the changes on acetate, the Duty Officer will record changes on the Daily Journal (DA Form 1594) for permanent record (Annex K).

7. SPECIAL PROCEDURES:

a. Downed or Missing Aircraft: All rescue and recovery operations involving downed 145th Avn Bn aircraft will be coordinated through 145th Avn BOC. For this purpose, BOC will schedule daily emergency standby aircraft to be available for immediate reaction to any notification of aircraft in distress. Although primarily concerned with 145th Avn Bn aircraft, BOC will remain prepared to react to any downed aircraft emergency which may arise in the III Corps area. This includes augmenting USAF Rescue Facilities with fireteam escort if requested. In coping with emergencies of this nature, it should be remembered that the rapid arrival of rescue and/or aircover aircraft at the scene will often determine the successful recovery of crew members. Therefore, minutes will not be wasted determining who goes after whom. The following steps will be taken on notification of downed aircraft:

- (1) Assemble emergency aircraft with armed escort.
- (2) Notify aero-medical evacuation facilities, if necessary.
- (3) Coordinate with III Corps AAE to obtain TAC USAF aircraft for overhead cover.
- (4) Coordinate with III Corps AAE to provide security of the site with ground forces, if necessary.
- (5) Notify designated organizations of all known information.
- (6) Notify Capitol Center and request any additional assistance required.
- (7) Contact 56th Transportation Company for recovery CH-47 Helicopter support (as required).

b. Aero-medical Evacuation: All medical evacuation requests will normally be processed through III Corps TOC. However, in many instances BOC will be required to effect necessary action. Should this occur, notify the 57th Medical Detachment; telephone AD 4121. The priorities of medical evacuation are as follows:

- (1) Urgent - Casualty must be removed immediately.
- (2) Priority - Casualty must be removed within twenty-four hours.
- (3) Routine - Casualty must be removed within seventy-two hours.

c. Alert Plans: In accordance with current plans, BOC will serve to maintain coordination and collect operational status reports for the CO, 145th Avn Bn. During alerts, (practice or actual) the Duty Officer remains at the desk and maintain communications with higher headquarters and subordinate units. He records all actions taken in the journal to include the status reports which will be called in to BOC by the subordinate units.

(1) During duty hours: The Duty Officer will receive instructions from the S-3 or the OIC, BOC.

(2) After duty hours: The Duty Officer will receive notification of the alert from the Officer-of-the-Day. He will then notify the S-3 and the OIC, BOC, and subordinate units in that order. (The off-duty BOC personnel will only be notified in the case of an actual alert).

d. Naval Gunfire: Within III Corps Tactical Area of Responsibility several different coastal areas have been designated as Naval Gunfire Areas. It is the responsibility of 12th Aviation Group AAD to notify this headquarters when naval gunfire is underway. The BOC Duty Officer will in turn notify all companies within the battalion of the naval gunfire location. (All areas are listed on the situation map and numbered. When calling naval gunfire to the subordinate units the number reference system will be used).

8. COMMUNICATIONS:

a. Hot Lines: 145th Commo Section will maintain communications with all subordinate units. In addition, Hot Lines will be maintained to 12th Avn Grp AAD, III Corps TOC, Capitol Center and other agencies and facilities as may become necessary.

b. 125th ATC (Capitol Center): The flight following system currently in effect will be utilized to provide communications with aircraft on missions and to augment coordination of operational requirements. The direct line to Capitol Center will be maintained for this purpose.

c. Class "A" Telephone: The Class "A" and /or commercial telephone system will be used to augment communications as necessary. However, it should be kept in mind that this system is both insecure and unreliable, and that maximum use of the Hot Line system is preferred. When the Class "A" phone must be used in connection with an emergency (downed aircraft, etc.), the operator will be so informed and a priority will be granted.

JCOOST
Lt. Col

ANNEXES:

1. Annex A-Master Mission Sheet
2. Annex B-Individual Mission Sheet
3. Annex C-Daily Staff Journal
4. Annex D-Aircraft Commitment Report
5. Annex E-OPREP 5 (Daily)
6. Annex F-Sorties and Hours Flown in Support of Operations
7. Annex G-OPREP 5 (Weekly)
8. Annex H-95-5 Checklist
9. Annex I-Downed Aircraft Report
10. Annex J-Unsatisfactory Mission Report
11. Annex K-HEDOPS Report
12. Annex L-Pathfinder Equipment
13. Annex Z-Distribution

DISTRIBUTION: Annex Z

OFFICIAL:

Baughman
3-3

1. Emergency Standby
2. Corps D.S.A.
3. Corps A.D.S.A.
4. CO 145th Avn Bn
5. 5XX S.A
6. 10XX S.A
7. 25XX S.A.
8. DONG NAI S.A.
9. C-3 S.F.
10. PsyWar # 1
11. PsyWar # 2
12. _____
13. 5XX # 2
14. 5XX # 3
15. 5XX # 4
16. 5 # 5
17. 10XX # 2
18. 10XX # 3
19. 10XX # 4
20. 10XX # 5
21. 25XX # 2
22. 25XX # 3
23. 25XX # 4
24. 25XX # 5
25. C-3 # 2
26. C-3 # 3
27. C-3 # 4

III CORPS UH-1

MISSIONS FOR _____

- 28. Chaplian # 1
- 29. Chaplian # 2
- 30. G-1
- 31. G-2
- 32. G-3
- 33. G-4
- 34. G-5
- 35. Engineer
- 36. Chemical
- 37. Arty
- 38. Signal
- 39. RF/FF
- 40. Navy
- 41. MP Advisor
- 42. Marines
- 43. USAF
- 44. N. G. F.
- 45. G-1 Mail Run
- 46. Ranger Group
- 47. _____
- 48. _____
- 49. _____
- 50. _____

III CORPS UH-1B (A)

MISSIONS FOR _____
Date

1. III Corps Emergency L. F. T. _____
2. Lightning Aug _____ T
3. III Corps DONG NAI L. F. T. _____
- 4a. PsyWar Escort # 1 _____
- 4b. PsyWar Escort # 2 _____
5. 5XX _____
 - a. LPT _____
 - b. LPT _____
 - c. LPT _____
 - d. LPT _____
 - e. LPT _____
 - f. LPT _____
 - g. LPT _____
6. 10XX _____
 - a. LPT _____
 - b. LPT _____
 - c. LPT _____
 - d. LPT _____
 - e. LPT _____
 - f. LPT _____
 - g. Platoon _____
7. 25XX _____
 - a. LPT _____
 - b. LPT _____
 - c. LPT _____
 - d. LPT _____
 - e. LPT _____

- a. HFT _____
- f. HFT _____
- g. Platoon _____
- 8. a. LFT _____
- b. LFT _____
- c. LFT _____
- d. LFT _____
- e. LFT _____
- f. LFT _____
- 9. a. HFT _____
- b. HFT _____
- c. HFT _____
- d. HFT _____
- e. HFT _____
- f. HFT _____
- 10. a. Platoon _____
- b. Platoon _____
- c. Platoon _____
- d. Platoon _____
- e. Platoon _____
- f. Platoon _____

III CORPS FIXED WING

3

MISSIONS FOR _____
Date

- 1. G-1 (COUIER) _____
- 2. G-1 # 2 _____
- 3. Naval Gun Fire _____
- 4. G-2 # 1 _____
- 5. G-2 # 2 _____
- 6. G-3 _____
- 7. _____
- 8. _____
- 9. _____
- 10. _____
- 11. _____
- 12. _____ T
- 13. _____
- 14. _____
- 15. _____

OFFICIAL:

JOOST
Lt Col

BAUGHMAN
S-3

Annex "B" (Individual Mission Sheet) To 145th Aviation Battalion SOP No. 6

(MISSION TITLE)

RECALL _____ A/C TAIL NUMBER _____

MSN NUMBER _____ DATE _____

NO & TYPE A/C UH-1D _____ UH-1B(A) _____ UH-1B _____ F/W _____

REQUESTING AGENCY:

FFV-II _____ 145TH STAFF _____

III CORPS _____ BOC/DO _____

MISSION RECEIVED BY: _____
(Units Opns Rep. - Time)

AIRCRAFT REPORT TO: _____
(Location) (Beginning - Release Time)

AIRCRAFT COMMANDER REPORT TO: _____
(Individual or Office)

MISSION CHANGES: _____

REMARKS AND SPECIAL INSTRUCTIONS: _____

AST 95-21 23 May 1964 (Rev 11 Mar 66)

OFFICIAL
BAUGHMAN
S-3

42
JOOST
Lt Col

145th AVIATION BATTALION DAILY AIRCRAFT COMMITMENT REPORT DATE

UNIT	TYPE A/C	ASSIGNED	OPN CONTROL	MSN RDY MAINT	NO CREW	AVAILABLE	1ST INF DIV	JLI RD CORPS	MACV	145TH AVN BN	COMMITTED	UNCOMMITTED
68th Avn Co	UH-1D											
	UH-1B (A)											
	UH-1B (M)											
118th Avn Co	UH-1D											
	UH-1B (A)											
	UH-1B (M)											
197th Avn Co	UH-1B (A)											
	UH-1B (A)											
	UH-1B (M)											
A/501st Avn Bn	UH-1D											
	UH-1B (A)											
	UH-1B (M)											
74th Avn Co	O-1F											
	UH-6A											
120th Avn Co	UH-1D											
	UH-1B											
	UH-1B (A)											
	UH-1B (M)											
2/171st Avn Co	UH-1B											
	UH-1B (A)											

REMARKS: _____

(145TH AVN BN FORM # 4 DATED 3 MAR 66, REVISED)

OFFICIAL:
BAUGHMAN
S-3

JOOST
Lt Col

44

ANNEX "E" (OPREP -5) (Daily) To 145th Aviation Battalion SOP No. 6
SOP No 6

JOINT MESSAGEFORM * CONTINUATION		SECURITY CLASSIFICATION	
FROM:			
OFFICIAL:		JOOST	
BAUGHMAN		Lt Col	
S-3			
SYMBOL		PAGE NO	NO OF PAGES
174-1		45	
		SECURITY CLASSIFICATION	INITIALS

Annex "F" (Sorties and Hours Flown in Support of Operations) To 145th Aviation Battalion SOP, No. 6

SORTIES AND HOURS IN SUPPORT OF SPECIFIC OPERATIONS OR ORGANIZATIONS									
UNIT	DATE		DATE		DATE				
	TROOP CARRIERS	ARMED	TROOP CARRIERS	ARMED	TROOP CARRIERS	ARMED	F/M	TOTAL	TOTAL
68th	/	/	/	/	/	/	/	/	/
74th	/	/	/	/	/	/	/	/	/
118th	/	/	/	/	/	/	/	/	/
120th	/	/	/	/	/	/	/	/	/
197th	/	/	/	/	/	/	/	/	/
A/501st	/	/	/	/	/	/	/	/	/
212/171	/	/	/	/	/	/	/	/	/
TOTALS	/	/	/	/	/	/	/	/	/

(145th AVN BN FORM # 9 TO 5-60 00)

OFFICIAL :
BAUGHMAN
S-3

JOOST
Lt Col
46

SECTION III RECON (Fixed Wing Only)

N-1 NUMBER OF SORTIES BY TYPE AIRCRAFT FUNCTION

A TYPE ACFT	B VIS RECONN	C PHOTO	D INFRA RED	E SLAR	F RDF/ ELEC	G FAC	H OTHER (SPECIFY)	I TOTAL
1. O1								
2. U6								
3. U1A								
4. U8								
5. OV1								
6. CV2								

SECTION IV (F/W AIRCRAFT Special Msn)

N-1 NUMBER OF SORTIES BY TYPE AIRCRAFT BY FUNCTION

A TYPE ACFT	B COMBAT TC CGO		C LOGISTIC TC CGO		D FLARE	E DEFOL IATION	F PSY WAR	G OTHER (SPECIFY)	H TOTAL	I TONS CGO	J PAX
1. O1											
2. U6											
3. U1A											
4. U8											
5. CV2											

SECTION V (Helicopter)

N-1 NUMBER OF TASKS AND SORTIES BY TYPE AIRCRAFT BY FUNCTION

A TYPE ACFT	B ARMED HELO		C COMBAT TC		D COMBAT CGO		E LOGISTIC TC		F LOGISTIC CGO		G COMMAND & CONTROL		H SAR	
	S	T	S	T	S	T	S	T	S	T	S	T	S	T
1. UH1														
2. OH23														
3. OH13														
4. CH37														
5. CH47														
6. CH54														

N-1 CONTINUED

TYPE ACFT	I CAS		J RECONN		K FAC		L TAC RECOVERY		M OTHER		N TOTAL		O TONS CGO		P PAX	
	S	T	S	T	S	T	S	T	S	T	S	T	S	T	S	T
1. UH1																
2. OH23																
3. OH13																
4. CH37																
5. CH47																
6. CH54																
TOTAL																

Z-1 RESULTS

D OTHERS (SPECIFY)

VC KIA	B STRUCTURE		C SM/PAMS	
	DAM	DEST	DAM	DEST

Z-2 TOTAL ORDNANCE EXPENDED

Z-3

A	B	C	D	E
7.62MM	5.56 MM	2.75 MM	50 CAL	40 MM

CASUALTY EVAC

UNSATISFACTORY MISSION REPORT

- (A) DATE _____
- (B) UNIT MAKING REPORT _____
- (C) NUMBER AND TYPE A/C _____
- (D) A/C CMDR, FIRE TEAM or FLIGHT LDR _____
- (E) UNIT SUPPORTED _____
- (F) SCHEDULED REPORTING TIME AND PLACE _____
- (G) ACTUAL REPORTING TIME _____
- (H) TIME RELEASED _____
- (I) TOTAL FLYING HOURS _____
- (J) MISSION (INCLUDE MSN NUMBER) _____

- (K) WAS/WERE A/C or FIRE TEAM BRIEFED UPON ARRIVAL _____
- (L) PROBLEMS ENCOUNTERED ON MISSION (BE SPECIFIC _____

- (M) RECOMMENDATIONS FOR IMPROVEMENT _____

ORGN _____

CONFIDENTIAL
(When Completed)

As of _____ 2300H

8. UTC _____

9. UNIT _____

10. U NAME _____

13. Home PAC _____

14. XFER _____

15. OFCOM _____

17. LOC _____

18. COORD _____

19. CMDB _____

203. CINCAT _____

21. ACTV CO _____

22. PERS AUTH _____

COMBAT READINESS CATEGORY _____

25. MERSD (3) _____

23. NEOPT _____

23-1 MAJ Equip Auth _____

24. MECAP _____

25. MERSD (3) _____

27. YEOHC (3) _____

MAJ Equip Ident _____

MAJ Equip Auth _____

MAJ Equip Cpld _____

MAJ Equip No _____

MAJ Equip Rdy _____

a. _____ C

b. _____ C

c. _____ C

d. _____ C

Commander's Comments: _____

MIN ACFT ASG CL _____

MIN ACFT OPR RPY CL _____

MIN PERS /SG CL _____

C2 _____

C2 _____

C2 _____

C3 _____

C3 _____

C3 _____

CONFIDENTIAL (When Completed)

OFFICIAL:

BAUGHMAN

JOOST
Lt Col

LINE ITEM NUMBER	ITEM DESCRIPTION	STRENGTH FULL	STRENGTH REDUCED
108050	Decontaminating Apparatus Portable 1 1/2 Qt	2	2
108171	Dectector, Kit Chemical Agent VGH	1	1
222752	Compass, Magnetic Lensatic 1.58 In. Dia. Card	15	12
232940	Flashlight, Plastic right angle 2 cell miniature flange lamp waterproof	15	12
231941	Flashlight, Plastic baton TY 2 cell miniature flange lamp waterproof	22	16
24909300	Light Set, marker landing & drop zone	4	4
259900	Protractor, Semicirc plastic 6 in dia 1-2 deg grad	2	2
401248	Binocular, 6x30 military reticle	3	3
94469600	Rifle, 5.56 XM 16 - E - 1	15	12
457110	Trailer, amphibious Cargo 1/4 ton 2 wheel	1	1
457190	Trailer, Cargo 3/4 ton 2 wheel	1	1
461790	TRUCK, Utility 1/4 ton 4x4	1	1
460080	TRUCK, Cargo 3/4 ton 4x4 w/w	1	1
465380	Watch, wrist, grade II	15	12
529100	Goggles, sun 2 plastic lens 1 colorless 1 polarized green	15	12
450500	Panel, marker aerial liaison nylon 6 ft long 2 ft wide	62	62
605470	Beacon, AN/CBX - 1 AN/CBX-1	4	4
609625	Charger, radiac detector PP/1578/PD	2	2
634670	Radiometer, IM-93/UD	15	12
634675	Repair kit, tentage	6	6
643100	Radio set, AN/VRC - 53	2	2
660060	Reel, equipment DL-11	2	2
665090	Signal lamp, equipment SE-11	10	10
668130	Reel, Cable dr-8	2	2
678260	Telephone set, TA-312/PT	4	4
697830	Wind measuring set, AN/FMQ - 3	10	10
698390	Wire, wd-1/TT MX 306/G	6	6
698535	Splicing kit, telephone cable MK-356/G	1	1
960010	Antenna, AR-791	4	4

OFFICIAL:

JOCST
Lt Col

BAUGHMAN
S-3

Distribution:

1 each Company, 145th Aviation Battalion
1 S-3, 145th Aviation Battalion

OFFICIAL:

JOOST
Lt Col

BAUGHMAN
S-3

AVAW-FC

2 February 1966

SUBJECT: After Action Report, 145th Aviation Battalion Operations 82-65,
82-65AA, and 2-66

TO: Commanding General, 1st Infantry Division, APO San Francisco
96345
Commanding Officer, 12th Aviation Group, APO San Francisco
96307
Senior Advisor, III Corps, APO San Francisco 96227

1. TASK ORGANIZATION:

a. Battalion Headquarters:

145th Aviation Battalion Command and Control Helicopter
74th Aviation Company (-)
197th Aviation Company (-)

b. 1st Flight Element: A Company, 501st Aviation Battalion:

11 UH-1D Helicopters
5 UH-1B (Armed) Helicopters
1 UH-1B (Maint) Helicopter

c. 2nd Flight Element: A Company, 82nd Aviation Battalion:

11 UH-1D Helicopters
5 UH-1B (Armed) Helicopters
1 UH-1B (Maint) Helicopter

d. 3rd Flight Element: 116th Aviation Company:

12 UH-1D Helicopters
5 UH-1B (Armed) Helicopters
1 UH-1B (Maint) Helicopter

e. 4th Flight Element: 118th Aviation Company:

10 UH-1D Helicopters
5 UH-1B (Armed) Helicopters
1 UH-1B (Maint) Helicopter

ANNEX B

53

f. 5th Flight Element: A Company, 1st Aviation Battalion:

11 UH-1D Helicopters
5 UH-1B (Armed) Helicopters
1 UH-1B (Maint) Helicopter

g. Support Element:

145th Aviation Battalion Communications Section
145th Aviation Battalion Pathfinder Detachment
145th Aviation Battalion POL Section
56th Transportation Company (-)
57th Medical Detachment (Air Ambulance) (-)

2. MISSION: The 145th Aviation Battalion provided air movement, armed helicopters, radio relay, and surveillance support to the 173rd (US) Airborne Brigade for ground convoy cover and the air movement to a forward staging site, (LZ WHISKEY, vicinity of Bao Tri, coordinates XT 545048) for three Battalions (1st Battalion Royal Australian Regiment, and the 1st and 2nd Battalions of the 503rd Airborne Infantry); thereafter, conducted three airmobile combat assaults into three landing zones: LZ VODKA (coordinates XT 450008) with the 1/503 Infantry, LZ SCOTCH (coordinates XT 485042) with the 1/RAR, LZ WINE (coordinates XS 535960) with the 2/503 Infantry beginning 010630 January 1966; and prepared to lift a reaction force into designated LZ's within three hours.

3. SUMMARY OF OPERATIONS:

a. 1-2 Jan 66

(1) The 145th Aviation Battalion supported this operation in four phases:

PHASE I: The 145th Aviation Battalion (Reinf) assembled troop carriers, armed helicopters, and the necessary Command and Control elements at the Bien Hoa staging area (SNAKEPIT) under the hours of darkness for final briefing and organization for combat.

PHASE II: The initial air movement consisted of a repositioning of three battalions of the 173rd (US) Airborne Brigade to LZ WHISKEY. The landing zone was secured by elements of the 25th ARVN Division and the landings were unopposed and without incident.

PHASE III: The 145th Aviation Battalion executed two combat assaults into LZ VODKA. The 1st Battalion, 503rd Airborne Infantry, was lifted from LZ WHISKEY into LZ VODKA and presented no major problems.

Initial identification of the landing zone was difficult due to the numerous canals, pineapple groves, and similar looking rice paddies in the area. Light sniper fire was received by all flight elements during approaches and departures to LZ VODKA. This landing zone had been prepared for the combat assault with friendly artillery, tactical air, and armed helicopters. Phase III continued with 2 combat assaults into LZ SCOTCH with the 1st Battalion, Royal Australian Regiment. These combat assaults were executed smoothly with no ground fire being received. Friendly artillery prepared LZ SCOTCH for 10 minutes; however, the fire was ineffective as it did not strike around the periphery of the LZ. Most of the rounds fell at least 400 meters southwest of the intended target. During this phase of the operation 5 troop carriers were dispatched back to LZ WHISKEY to airlift 50 additional troops to LZ VODKA. This was aborted, however, due to insufficient fuel remaining to orbit while artillery units completed a firing mission in the vicinity of the landing zone. Armed helicopters of the 197th Aviation Company supported ground elements of the 1st Battalion, 503rd Airborne Infantry during their ground attack on enemy positions after their combat assault landing. Troop carriers were defueled to 1100 lbs due to density altitude and to allow a sufficient aircraft handling safety margin.

PHASE IV: The 145th Aviation Battalion continued the operation on 2 January 1966 by airlifting the 2nd Battalion, 503rd Airborne Infantry from LZ WHISKEY into LZ WINE beginning 020800 January 1966. During the first combat assault into LZ WINE moderate automatic weapons and small arms fire was received by all flight elements. In order to lessen the exposure of the flight elements to the hostile fire the landing direction was changed for the second lift. This allowed tactical air to continue strikes against enemy positions on the immediate southern periphery of the landing zone. One aircraft from the 116th Aviation Company received hits from hostile fire and one door gunner was wounded. The 197th Aviation Company's armed aircraft remained on station providing overhead cover and assisting the ground commander as required.

SEQUENCE OF EVENTS

010615 Jan 66	Final Briefing
0600	145th Avn Bn (Reinf) closed SNAKEPIT
0700	145th Avn Bn (Reinf) departed SNAKEPIT
0720	1st Landing LZ WHISKEY (1/503)
0805	2nd Landing LZ WHISKEY (1/503)
0830-0915	145th Avn Bn refueled and departed Dien Hoa
0935	3rd Landing, LZ WHISKEY (1/RAR)
1020	4th Landing, LZ WHISKEY (1/RAR)
1045-1130	145th Avn Bn refueled and departed LZ WHISKEY
1150	5th Landing, LZ WHISKEY (2/503)
1240	6th Landing, LZ WHISKEY (2/503)
1300-1345	145th Avn Bn refueled and departed Dien Hoa
1405-1410	Tac Air prestrike, LZ VODKA
1405-1410	145th Avn Bn arrived and departed Dien Hoa
1410-1420	Arty Prep, LZ VODKA
1425	1st Landing, LZ VODKA
1453	2nd Landing, LZ VODKA

1515-1545	145th Avn Bn refueled and departed Bien Hoa
1535-1605	Tac Air prestrike, LZ SCOTCH
1605-1615	Arty prep, LZ SCOTCH
1615-1620	Armed helicopter prestrike, LZ SCOTCH
1620	1st Landing, LZ SCOTCH
1650	2nd Landing, LZ SCOTCH
1715	145th Avn Bn (Reinf) arrived Bien Hoa, refueled and released
020630 Jan 66	145th Avn Bn closed SNAKEBIT
0645	Final Briefing
0725	145th Aviation Battalion departed Bien Hoa
0715-0745	Tac Air prestrike, LZ WINE
0745-0755	Arty prep, LZ WINE
0745	145th Avn Bn arrived LZ WHISKEY
0748	145th Avn Bn departed LZ WHISKEY
0755-0800	Armed helicopter prestrike, LZ WINE
0800	1st Landing, LZ WINE (2/503 Inf)
0830	2nd Landing, LZ WINE (2/503 Inf)
0900	145th Avn Bn refueled and were released at Bien Hoa

(2) Supporting this operation, the 145th Aviation Battalion committed 95 rotary wing and one fixed wing aircraft flying a total of 395 hours and 925 combat sorties.

d. 3 Jan 66:

(1) The 173rd (US) Airborne Brigade continued search and destroy operations against Viet Cong forces, supplies, and installations by conducting airmobile assaults from LZ VODKA to LZ SODA, vicinity coordinates XS 535935. Four lifts were required to airlift one Battalion (1/503rd) into the landing zone. The operation was initiated at 1100 hours and was completed at 1230 hours. Light ground fire was received; no aircraft were hit and no casualties were reported.

SEQUENCE OF EVENTS

1000	145th Avn Bn (Reinf) closed Bien Hoa (SNAKEBIT)
1015	Final Briefing
1045	Pathfinder reported LZ VODKA
1050-1130	Tac Air prestrike, LZ SODA
1100	145th Avn Bn departed Bien Hoa
1130-1140	Arty prep, LZ SODA
1133	145th Avn Bn arrived, loaded troops, and departed LZ VODKA
1140-1145	Armed helicopter prestrike, LZ SODA
1145	1st Landing, LZ SODA
1200	2nd Landing, LZ SODA
1215	3rd Landing, LZ SODA
1230	4th Landing, LZ SODA
1230	Mission completed and flight elements released

(2) In support of this operation the 145th Aviation Battalion committed 58 helicopters and flew 84.9 hours and 200 sorties.

c. 5 Jan 66:

(1) The 173rd (US) Airborne Brigade continued its operations against Viet Cong forces with one Battalion (1/503) conducting airmobile assaults into two landing zones, LZ NORTH (coordinates XT 462038) and LZ SOUTH (coordinates XT 457030). The plan called for the simultaneous landings of two flight elements in separate landing zones with elements of the 1/503 Airborne Infantry Battalion. The troops were picked up at landing Zone VODKA and the flight elements conducted a forming turn in order to coordinate the simultaneous landings in the two LZ's. The pickup, forming turns, and approach were executed perfectly, and utilizing their organic armed aircraft the flight elements suppressed their way into the landing zones as planned. Two lifts were performed in this manner with light fire being received on the departure route after the second landing. All flight elements returned to home station and were placed on a one hour alert to airlift reserve forces or conduct an extraction on order.

SEQUENCE OF EVENTS

050630 Jan 66	Final Briefing, SNAKE PIT
0705	145th Avn Bn closed SNAKE PIT
0745	Pathfinder reported to LZ VODKA
0800-0820	Tac Air prep, LZ's NORTH & SOUTH
0818	145th Avn Bn arrives LZ VODKA
0820-0825	Arty prep, LZ's NORTH & SOUTH
0825-0830	Armed helicopter prestrikes, LZ's NORTH & SOUTH
0830	1st Aslt Landing, LZ NORTH
0830	1st Aslt Landing, LZ SOUTH
0838	2nd Aslt Landing, LZ NORTH
0838	2nd Aslt Landing, LZ SOUTH
0915-1000	145th Avn Bn refueled at Bien Hoa
1000-1500	On standby for commitment of reserves
1630-1800	Extracted 1/503rd Abn Inf; 145th Avn Bn released

(2) During this portion of the operation the 145th Aviation Battalion committed 46 helicopters and flew 49.3 hours and 167 sorties.

4. ADMINISTRATION AND LOGISTICS:

a. Supply:

(1) On 1 January 1966, rearming and refueling of aircraft was conducted at Bien Hoa and Duc Hoa. Troop carrier aircraft refueling at Bien Hoa required 36,456 gallons of JP/4 while armed aircraft refueling at Duc Hoa required 12,350 gallons of JP/4.

(2) Refueling on 2 January 1966 was conducted at Bien Hoa for the initial refueling, requiring 1,200 gallons of JP/4. Refueling for troop carriers was conducted at Tan Son Nhut Air Base requiring 9,375 gallons; Armed aircraft refueled at Duc Hoa using 12,400 gallons of JP/4. The continuing operation required that 2 men and pumping units remain on station at Duc Hoa.

(3) Refueling on 3 January 1966 required 1,200 gallons of JP/4. Upon completion of the operation, another refueling operation was conducted requiring 6,000 gallons of JP/4.

(4) Refueling operations were conducted at Bien Hoa on 5 January 1966 before and after completion of the operation. Armed aircraft refueled at Duc Hoa. A total of 6,000 gallons of JP/4 fuel was used at both sites.

b. Maintenance: The following aircraft experienced maintenance problems or combat damage.

(1) 118th Aviation Company:

(a) UH-1D, SN 63-8675, received bullet damage. Aircraft continued mission and was repaired at home station after the lift.

(b) UH-1D, SN 63-8597, was inspected and found to have a leaking servo. Aircraft was flown to home station and servo replaced.

(c) UH-1D, SN 64-13714, received bullet damage to skid and right door. Aircraft continued mission and was repaired at home station upon completion of the operation.

(2) 68th Aviation Company:

UH-1D, SN 64-14095, received one round of small arms fire through the main rotor blade on final approach to a LZ. The aircraft was flown to home station and the blade repaired.

(3) A Company, 501st Aviation Battalion:

(a) UH-1D, SN 64-13712, failed to start prior to departure for the lift. Aircraft inspection revealed the exciter box was inoperative. Exciter box was replaced and aircraft was returned to a flyable status.

(b) UH-1D, SN 64-13563, experienced loss of power and low RPM on take off from Bien Hoa. Aircraft was returned to Bien Hoa and repair was effected.

(4) 197th Aviation Company:

UH-1D, SN 63-13949, and SN 63-13974, aircraft received minor bullet damage during low level reconnaissance. Aircraft continued the mission and were repaired at home station upon return.

(5) "A" Company, 82nd Aviation Battalion:

(a) UH-1D, SN unknown, received round through main rotor blade. Aircraft returned to 166th Transportation Detachment for repairs.

(b) Two UH-1D's SN unknown, received skid damage due to small arms fire. No major damage was caused and aircraft continued mission.

c. Medical:

(1) The Battalion Flight Surgeon overflew the flight routes and landing zones throughout the operation.

(2) The 93rd Medical Detachment ambulance was on continual standby at the Snakepit.

(3) Two casualties from 197th Aviation Company were evacuated to 3rd Field Hospital. These injuries were received as a result of ground fire as aircraft approached Duc Hoa for refueling.

5. COMMENTS:

a. Landing Zone WHISKEY was a recently harvested rice paddy, and a large amount of rice straw was ingested into the aircraft engines and accumulated around the engine air intake screen and compressor blades. This required air intake screens and compressors to be inspected and cleaned during each refueling operation.

b. Landings in multiple landing zones are extremely difficult to coordinate and control. If multiple landings are made upon completion of tactical air and artillery support; it points out the increased requirement for armed helicopters since the effort must be divided. This battalion is extremely short of armed helicopters in its armed helicopter company due to the continuous nightly requirement for LIGHTNING BUG, and due to the detachment of one armed platoon which is at Qui Nhon in support of Marine helicopter squadron HMM #363. Recommend that this platoon be returned to this Battalion at the earliest practicable date.

c. On 1 January 1966, a USAF Forward Air Controller, directing artillery strikes against the enemy flew his aircraft through the gun target line. His aircraft was hit by friendly artillery and exploded. Even though this officer had been thoroughly briefed, was fully aware of the gun target line, and had this information posted on his map, a slight miscalculation on his part resulted in a fatality and the loss of one aircraft. It is necessary that all aviators be cognizant of the inherent danger in this type of a situation, and that each aviator be thoroughly briefed on artillery adjustment procedures.

Charles M. Honour Jr.
CHARLES M. HONOUR JR.
Lt. Colonel Infantry
Commanding

145TH AVIATION BATTALION
APO San Francisco 96307

AVAM-FC

18 January 1966

SUBJECT: After Action Report, Operation 4-66, 145th Aviation Battalion,
8 January 1966

TO: Commanding General, 1st US Infantry Division, APO San Francisco
96345
Commanding Officer, 12th Aviation Group, APO San Francisco
96307
Senior Advisor, III AVN Corps, APO San Francisco 96227

1. TASK ORGANIZATION:

a. Battalion Headquarters:

145th Aviation Battalion Command and Control Helicopter
74th Aviation Company (-)
197th Aviation Company (-)

b. 1st Flight Element: 68th Aviation Company (ALL):

10 UH-1D Helicopters
5 UH-1B (Armed) Helicopters
1 UH-1B (Maint) Helicopter

c. 2nd Flight Element: 118th Aviation Company (ALL):

10 UH-1D Helicopters
5 UH-1B (Armed) Helicopters
1 UH-1B (Maint) Helicopter

d. 3rd Flight Element: A Co, 82nd Aviation Battalion:

10 UH-1D Helicopters
5 UH-1B (Armed) Helicopters
1 UH-1B (Maint) Helicopter

e. 4th Flight Element: 155th Aviation Company:

10 UH-1D Helicopters
5 UH-1B (Armed) Helicopters
1 UH-1B (Maint) Helicopter

f. 5th Flight Element: A Co, 501st Aviation Battalion:

10 UH-1D Helicopters
5 UH-1E (Armed) Helicopters
1 UH-1D (Maint) Helicopter

g. Support Element:

145th Aviation Battalion Communications Section
145th Aviation Battalion Maintenance Section
145th Aviation Battalion POL Section
145th Aviation Battalion Pathfinder Detachment
56th Transportation Company (-)
57th Medical Detachment (-)

2. **MISSION:** The 145th Aviation Battalion (Reinf) provided troop carrier, armed helicopter, control and surveillance aircraft for 173rd (US) Airborne Brigade (1960 troops; 1/RAR, 1/503 and 2/503) airmobile assault into multiple landing zones (LZ MARCH, coordinates XT 644283, LZ APRIL, coordinates XT 614261, and LZ MAY, coordinates XT 625288) 13 Km southwest of Ben Cat, beginning 080930 January 1966.

3. **SUMMARY OF OPERATION:**

a. Flight elements of the 145th Aviation Battalion (Reinf) closed at 0755 hours at the Bien Hoa SINKPIT staging area for final preparation and organization for combat. The final briefing was conducted by the Air Mission Commander and Staff for subordinate units; flight crews received final instructions and prepared for departure.

b. Battalion flight elements departed Bien Hoa at 0855 hours enroute to landing zone WHISKEY (Bao Trai, coordinates XT 545048) to load assault elements of the 1/RAR. The initial airmobile assault into LZ MARCH with the 1/RAR was preceded by intense artillery and air preparation; however, all flight elements received heavy automatic weapons and small arms fire on final approach, in the immediate vicinity of the LZ, and upon departure. Prior to the arrival of a second lift with reinforcing elements for LZ MARCH, tactical air strikes were directed along the helicopter approach and departure routes by the Command and Control helicopter. The second lift into the area also received heavy fire from the ground. Upon completion of the second lift all battalion elements returned to Bien Hoa and Duc Hoa for refueling and rearming. The Command and Control helicopter remained on station to provide direction and assistance to the ground elements. A light fire team of the 197th Aviation Company remained to cover ground operations, escort the Command and Liaison helicopter in and out of the area and to patrol the Song Saigon river. One Sampan (coordinates XT 665263) was discovered and destroyed under the direction of the airmobile force commander.

c. The 3rd and 4th assaults into LZ APRIL with the 1/503rd Airborne Infantry, as well as the 5th and 6th assaults into LZ MAY with the 2/503rd Airborne Infantry, all received heavy automatic weapons and small arms fire along the approach and departure routes from the LZ's. Each LZ had been extensively prepared prior to the assault force arrival; however, this vividly points out the requirement to also concentrate prestrikes along the approach and departure routes. Air strikes were redirected from the Command and Control helicopter between each lift in an effort to neutralize enemy ground fire. Armed helicopter and troop carrier gunners fired close and continuous suppressive fire entering and departing LZ's and are credited with keeping enemy fire at a minimum during the final seconds of the assault landings. Although flight visibility in the operational area was approximately two miles, all flight elements maintained extremely fine separation and timing moving into and out of the LZ's.

d. The 197th Aviation Company performed column cover, reconnaissance of the flight routes, landing zones, and armed cover of the surrounding area.

e. One O1-F aircraft of the 74th Aviation Company provided observation and surveillance, radio relay, and weather advisories throughout the operation.

f. The 145th Aviation Battalion Command and Control helicopter effected necessary coordination and control of airmobile flight elements, tactical air strikes, and other supporting fires. One enemy small arms round hit the Command and Control helicopter in the left troop compartment door departing the helicopter through the cabin roof. Upon completion of the operation the Command and Control group were taken to the Brigade Forward Command Post.

g. Eighty five rotary wing and one fixed wing aircraft were committed by the battalion in support of the operation. During the airmobile assaults, 1,321 sorties, and 320.3 hours were flown. All flight elements were released for return to home station at 1500 hours.

SEQUENCE OF EVENTS

080745 Jan 66	145th Avn Bn Fwd CP Opened Bien Hoa
0755	145th Avn Bn Closed Bien Hoa
0800	Final Briefing
0855	145th Avn Bn departed Bien Hoa
0845-0915	Tac Air Prep LZ MARCH
0915-0925	Artillery prep LZ MARCH
0916	145th Avn Bn departed BT
0925-0930	Armed Hcptr prestrike LZ MARCH
0930	1st Aslt landing LZ MARCH (1/RAR)
1000	2nd Aslt landing LZ MARCH (1/RAR)
1030-1126	145th Avn Bn refueled and departed Bien Hoa

1115-1125	Arty Prep LZ APRIL
1125-1155	Tac Air Prep LZ APRIL
1146	145th Avn Bn arrived BT, loaded and departed
1155-1200	Armed Hcptr prestrike
1200	3rd Aslt landing LZ APRIL (1/503)
1230	4th Aslt landing LZ APRIL (1/503)
1300-1356	145th Avn Bn refueled and departed Bien Hoa
1345-1355	Arty Prep LZ MAY
1355-1425	Tac Air Prep LZ MAY
1416	145th Avn Bn arrived BT, loaded and departed
1425-1430	Armed Hcptr prestrike LZ MAY
1430	5th Aslt landing LZ MAY (2/503)
1500	6th Aslt landing LZ MAY (2/503)
1530	Released

4. ADMINISTRATION AND LOGISTICS:

a. Supply:

(1) Arrangements were made for 3 trucks (2½ ton) to be loaded with two 500 gallon bladders per truck to augment the tankers available at Bien Hoa. An additional tanker was requested from the 120th Aviation Company and one from A Company, 82nd Aviation Battalion making a total of 16 tankers available to refuel 60 aircraft at Bien Hoa.

(2) Further arrangements were made with 25th ARVN Division to furnish five 2½ ton trucks loaded with 15 drums of JP/4 at Duc Hoa. Six tankers were available to refuel 30 armed aircraft at Duc Hoa. On 7 January 1966, two men and additional pumping units were transported to Duc Hoa for refueling. A total of 14,700 gallons of JP/4 were required at Bien Hoa and 10,700 gallons at Duc Hoa.

(3) At approximately 1700 hours 8 January 1966, the men and equipment of the Battalion POL section were returned to home station. Other members of the section at Bien Hoa were released to return to home station at approximately 1400 hours.

b. Maintenance:

(1) The following aircraft of the 118th Aviation Company received combat damage as indicated:

(a) UH-1D, SN 64-13700, received bullet damage to the chin bubble. The aircraft was flown to home station for repair.

(b) UH-1D, SN 64-13726, received bullet damage to door post. The aircraft was flown to home station for repair.

(2) The full win aircraft of Company, 501st Aviation Battalion received damage as indicated.

(a) UH-1B, SN 63-12922, bullet damage to main rotor blades. Aircraft returned to home station for repairs.

(b) UH-1B, SN 63-12925, bullet damage to hydraulic lines. Aircraft returned to home station and lines were replaced.

(c) UH-1D, SN 64-13667, bullet damage to cargo compartment. Aircraft was inspected and continued mission. Aircraft was repaired at end of mission.

(d) UH-1D, SN 64-13669, made a hard landing in LZ causing damage to skids and underside of aircraft. Aircraft was flown to home station for repairs.

(3) The following aircraft from the 155th Aviation Company received damage as indicated.

(a) UH-1B, SN unknown, received a round through engine on approach to Duc Hoa. Temporary repairs were made and aircraft was flown to 56th Transportation Company maintenance area for thorough inspection and repairs.

(b) UH-1B, SN unknown, received a round through the main rotor blade and two rounds through the tail boom. Aircraft was flown to Tan Son Nhut Air Base where main rotor blade was replaced.

(4) The following aircraft from the 68th Aviation Company received damage as indicated:

(a) UH-1D, SN 64-13791, small arms round through main rotor blade. Aircraft returned to home station for blade repair.

(b) UH-1B, SN 64-14089, small arms round through main rotor blade. Aircraft landed at Duc Hoa where blade was changed and aircraft returned to home station.

(c) UH-1D, SN 64-13732, Battalion Command and Control aircraft, received a small arms round through left cargo door and through the roof of cargo compartment without damaging main rotor blades or rotor head. Aircraft continued mission and returned to home station for repairs.

c. Medical:

(1) the 93rd Medical Detachment ambulance was on standby in the SHAKFIT with the Battalion Surgeon.

(2) No casualties were reported as a result of the operation.

(3) Two crew members from 68th Aviation Company sustained minor burns as a result of a JP/4 splash during refueling. Personnel were treated at 93rd Medical Detachment and returned to Vung Tau.

64

5. COMMENTS: This operation, although complex in scope, was conducted in a highly professional and smooth manner. Coordination and timing between airborne elements, artillery and tactical air support was remarkably precise and accurate.

Charles M. Honour Jr.
CHARLES M. HONOUR JR.
Lt. Colonel Infantry
Commanding

HEADQUARTERS
145TH AVIATION BATTALION
APO SAN FRANCISCO 96227

AVAW-FC

10 March 1966

SUBJECT: After Action Report, 145th Aviation Battalion Operation 15-66,
020900 March 1966

TO: See Distribution

1. TASK ORGANIZATION:

a. Battalion Headquarters:

145th Aviation Battalion Command and Control Helicopter
74th Aviation Company (-)
197th Aviation Company (-)

b. 1st Flight Element: 68th Aviation Company (AML):

10 UH-1D Helicopters
5 UH-1B (Armed) Helicopters
1 UH-1B (Maint) Helicopter

c. 2nd Flight Element: A Company, 501st Aviation Battalion (AML):

At'chd: 4 UH-1B (Armed) Helicopters from 197th Aviation Company
10 UH-1D Helicopters
4 UH-1B (Armed) Helicopters
1 UH-1B (Maint) Helicopter

d. 3rd Flight Element: 118th Aviation Company (AML):

10 UH-1D Helicopters
5 UH-1B (Armed) Helicopters
1 UH-1B (Maint) Helicopter

e. Support Element:

145th Aviation Battalion Communication Section
145th Aviation Battalion Maintenance Section
145th Aviation Battalion Pathfinder Detachment
145th Aviation Battalion POL Section
56th Transportation Company (-)
57th Medical Detachment (Air Amb) (-)

2. MISSION: The 145th Aviation Battalion provided command and control, troop carriers, and armed aircraft to support three Battalion sized airmobile assaults of 25th Division i.to TAOR, 20 Km south of Tay Ninh; thereafter provided troop carriers for logistical support and armed helicopters for continuous overhead cover of ground operations and prepared for extraction on order.

3. SUMMARY OF OPERATION:

a. Battalion combat and supporting elements colsed the Battalion forward staging area (SNAKEPIT) for final organization, briefing, and preparation for combat 020710 February 1966.

b. The first flight element departed the SNAKEPIT at 0815 hours enroute to LZ JOHN (Cu Chi, coordinates XT 641115) for the initial loading of assault troops. Troops were loaded and flight elements departed for the objective area. The initial objective had been prepared by tactical air utilizing 500 lb high explosive bombs. In addition tactical air prepared the landing zone for the admission of the troop carriers. One armed platoon from the 197th Aviation Company provided a full prestrike of the LZ and suppressive fires during the initial assault. The first landing into LZ MAY (coordinates XT 148309) was completed at 0904 hours. Late tactical air resulted in the LZ time being delayed four minutes. Heavy small arms and automatic weapons fire was received by all flight elements during the departure from LZ MAY. The second and third troop loading site was located at LZ FRANK, (coordinates XT 485194) Trang Bang air strip. The second landing was made into landing zone DAN (coordinates XT 160307) at 0944 hours and light small arms and automatic weapons fire was received on the approach and departure from the landing zone. A larger number of troops than expected required two troop carriers to be diverted back to LZ FRANK to complete the lift into LZ DAN. Refueling was conducted at Tay Ninh after completion of the second assault. Flight elements departed Tay Ninh airstrip at 1038 hours enroute to LZ FRANK to load troops for the last lift. The third assault was complete at 1122 hours into LZ JANE, (coordinates XT 202341), with only light small arms fire received during the departure from the loading zone. All aircraft returned to the SNAKEPIT for refueling and preparation for assigned III Corps missions and remainder of the day.

c. The 197th Aviation Company (Armed) provided armed aircraft for flight route and surrounding area reconnaissance, LZ marking and prestrikes, and continuous over head cover of the ground operation. During the ground operation, after the lift, 10 Viet Cong were spotted in the open, fleeing the area. The armed ships attacked and killed all of the insurgents.

d. The 74th Aviation Company (CAL) provided one O-1F for radio relay, aerial surveillance and weather advisory throughout the air movement phase of the operation. Thereafter, provided continuous 24 hour aerial support for the duration of the ground operation.

SEQUENCE OF EVENTS

020710 Feb 66	145th Avn Bn closed BH
0715	Final Briefing
0745	Pathfinder reported LZ JOHN
0750	C&C reported Duc Hoa
0755-0825	Tac Air prep of objective
0815	145th Avn Bn departed Bien Hoa
0825-0855	Tac Air prep of LZ MARY
0834-0837	145th Avn Bn arrived, loaded, and departed LZ JOHN
0855-0900	Armed Hcptr prep LZ MARY
0900-0904	1st Aslt landed LZ MARY
0905-0935	Tac Air prep LZ DAN
0915-0918	145th Avn Bn arrived LZ FRANK
0924	145th Avn Bn departed LZ FRANK
0935-0940	Armed Hcptr prep LZ DAN
0940	2nd Aslt landed LZ DAN
0953	145th Avn Bn arrived Tay Ninh, and refueled
1038	145th Avn Bn departed Tay Ninh
1043-1113	Tac Air prep LZ JANE
1056-1059	145th Avn Bn arrived LZ FRANK
1113-1118	Armed Hcptr prep LZ JANE
1118	3rd Aslt landed LZ JANE
1158	145th Avn Bn arrived Bien Hoa, refueled and released

e. In support of the air movement the 145th Aviation Battalion committed one O-1F airplane and 57 helicopters, flying a total of 161.4 hours and 431 combat sorties. A total of 821 troops were lifted from two pick up sites into the operational area. The Battalion Command and Control helicopter was used by the 25th ARVN Division Command Group and the Air Mission Commander, Air Liaison Officer, artillery, and other supporting elements during the air movement of the Division.

f. At 051000 March 1966 the 145th Aviation Battalion was alerted that an extraction of the 25th ARVN Division from their TACR and subsequently conduct combat assaults into a new operational area 6 Km southeast of Trang Bang would begin at 060700 1966. The Battalion S-3 and S-2 departed immediately for Duc Hoa, 25th Division headquarters, to coordinate with the Senior Advisor and Advisory Staff. In addition, a reconnaissance of the pick up sites was made. Two pick up sites and four landing zones were selected. A detailed operational briefing was held at the Battalion S-3 office at 051600 hours for unit commanders and staff. The tactical plan called for night extraction from the selected pickup zone and a day break combat assault into two landing zones simultaneously. Troop carriers closed the Battalion staging area (SNAKEPIT), during the hours of darkness at 060450 March 1966 for final briefing and organization for combat. The organic armed escort and the reconnaissance elements from the 197th Aviation Company were positioned forward to Duc Hoa, refueled, and prepared to rendezvous with the flight elements enroute to the pick up site. This forward positioning enabled the armed helicopters to remain on station during the extraction and combat assault without refueling. Flight elements departed the SNAKEPIT during the hours of darkness at 060606 March 1966 for the 1st extraction. The 145th Aviation Battalion Pathfinder had preceded the lift elements and prepared for the pickup sites with approach lights and XM 172 marker panels to indicate the extremities of the landing zone.

The marker panels are presently under test by this battalion and are rendering excellent results. The weather in the operational area was marginal at take off; however, the decision was made to attempt to keep the airmobile operation on schedule to effect the greatest amount of surprise for the extraction and combat assault. The Command and Control helicopter arrived in the operational area prior to the troop carriers and observed the weather deteriorating to such extent that the operation would have to be delayed. All flight elements returned to the SNAKEPIT to standby. Weather delays were announced in one hour increments for the first two hours and thirty minutes thereafter. During the standby, flight crews participated in physical training and Col Joost, the Battalion Commander made a combat readiness inspection of the 68th Aviation Company. After a three hour weather delay the flight elements departed the SNAKEPIT to begin the extraction and subsequent combat assaults. After loading the troops, the enroute to the landing zone flight elements executed a forming turn to establish flight interval for the simultaneous landings in the initial assault. To achieve maximum surprise, the LZ was not prestruck by Tac Air or armed helicopters; in addition, a low level approach was executed with friendly artillery firing diversionary fires to provide noise to cover the approaching helicopters and confuse the enemy as to the actual location of the landing zone. Two lifts were required to complete the airmobile operation. Only light small arms fire was received and no aircraft were hit. The operation was completed at 1154 hours and the flight elements were released to perform scheduled III Corps missions.

g. In support of this operation the Battalion committed 50 troop carriers, 30 armed aircraft and one O-1F fixed wing airplane. A total of 266.2 hours and 447 combat sorties were flown.

h. The 197th Aviation Company provided route and surrounding area reconnaissance and armed overhead cover of the ground operation.

i. The 74th Aviation Company provided one O-1F for weather advisory, radio relay and aerial surveillance.

j. The Command and Control helicopter carried the ground command group during the operation, controlled the air movement and provided vector assistance during the low level phase of the operation.

4. ADMINISTRATION AND LOGISTICS:

a. Supply:

(1) Refueling and rearming was conducted at Tay Ninh airstrip.

(2) On 1 March 1966, the Battalion S-4 transported eight (8) fuel pumping units to Tay Ninh and made arrangements with the Sector S-4 for eight (8) 2½ ton vehicles to be loaded with fifteen (15) drums of JP/4 on each vehicle.

(3) A total of fifty-five (55) aircraft were refueled in 45 minutes for a total consumption of 10,200 gallon of JP/4.

b. Maintenance:

(1) A maintenance representative was located at Tay Ninh throughout the operation.

(2) The following aircraft from the 68th Aviation Company experienced maintenance problems as indicated:

(a) UH-1D, SN 64-13810, would not start after refueling at Tay Ninh. Inspection revealed that the exciter box was inoperative. The maintenance aircraft from the 68th returned to home station for the part.

c. Medical:

(1) 93rd Medical Detachment provided an airmobile aid station at Tay Ninh throughout the operation.

(2) No casualties were reported or treated during operation.

5. COMMENTS AND RECOMMENDATIONS:

a. Artillery clearance for flight route corridors are coordinated and confirmation received with 1st Division FSCC prior to the execution of the operation. In addition, the command and control helicopter reconfirms the flight route clearance with the controlling agency just prior to the arrival of the troop carriers. Artillery firing within flight corridors, or without prior warning to aircraft within the range of artillery continues to be a problem. CORSAIR CONTROL, the artillery advisory for 1st Division, was not cognizant of the flight route clearance. It is imperative that all artillery controlling agencies are aware of previously cleared flight routes and off the extreme hazard of uncontrolled artillery fire while large numbers of aircraft are operating within the area. In addition the FM frequency or radio assigned to CORSAIR CONTROL is weak, garbled, and often times unreadable; in addition, the back up UHF frequency is either unreliable or not monitored.

b. The medium cargo helicopter assigned to transport the command group and supporting artillery was briefed on the location to rendezvous for armed escort and the assigned frequency to monitor for instructions during the lift. The attached CH-47 from the 147th Aviation Company failed to report or respond on the assigned frequency. The avionics and signal difficulties experienced by these helicopters is a major communications and operational problem and should receive immediate attention.

c. The dry season continues to present a major problem in helicopter staging and a detriment to safe operations. The supported unit at Doc Hoa is aware of this and have provided a PSP pad for refueling a limited number of helicopters; however, this provides only limited relief and often fails to completely reduce the dust hazard. It is recommended that major emphasis be placed on this problem and that additional equipment, personnel and facilities be provided so that adequate landing and staging areas are available for airmobile operations.

Horst K. Joost

HORST K. JOOST
Lt Col Infantry
Commanding

DISTRIBUTION:

Special

HEADQUARTERS
145TH AVIATION BATTALION
APO San Francisco 96227

AVAW-FC

24 March 1966

SUBJECT: After Action Report, 145th Aviation Battalion Operation 18-66
090730 March 1966

TO: See Distribution

1. TASK ORGANIZATION:

a. Battalion Headquarters:

145th Aviation Battalion Command and Control Helicopter:
74th Aviation Company (-)
147th Aviation Company (-)
197th Aviation Company (-)

b. 1st Flight Element: A Company, 82d Aviation Battalion (AML):

10 UH-1D Helicopters
4 UH-1B (Armed) Helicopters
1 UH-1B (Maint) Helicopter

c. 2nd Flight Element: 118th Aviation Company (AML):

10 UH-1D Helicopters
4 UH-1B (Armed) Helicopters
1 UH-1B (Maint) Helicopter

d. 3rd Flight Element: 116th Aviation Company (AML):

10 UH-1D Helicopters
4 UH-1B (Armed) Helicopters
1 UH-1B (Maint) Helicopter

e. 4th Flight Element: 68th Aviation Company (AML):

10 UH-1D Helicopters
4 UH-1B (Armed) Helicopters
1 UH-1B (Maint) Helicopter

f. 5th Flight Element: A Company, 501st Battalion (AML):

10 UH-1D Helicopters
4 UH-1B (Armed) Helicopters
1 UH-1B (Maint) Helicopter

g. Support Element:

145th Aviation Battalion Communication Section
145th Aviation Battalion Maintenance Section
145th Aviation Battalion Pathfinder Detachment
145th Aviation Battalion POL Section
56th Transportation Company (Maint)(-)
57th Medical Detachment (Air Ambulance)(-)

2. MISSION: The 145th Aviation Battalion (Reinf) provided troop carriers, armed helicopters and command and control aircraft for the 173rd (US) Airborne Brigade airmobile assaults (1/RAR, 1/503) into landing zone # 12 (coordinates YT 082425) beginning 090730 March 1966; and landing zone # 8 beginning 110800 March 66; there after provided logistical support as required and necessary airmobile force for extraction on 21st and 22nd March 66.

3. SUMMARY of OPERATION:

a. A detailed command and staff briefing was conducted 081600 March 66 for all battalion and supporting elements in preparation for 173rd Airborne Brigade operation SILVER CITY. On 090615 Mar 66, the morning of the operation, a final briefing for flight crews and support personnel was conducted at the battalion forward command post (SNAKEPIT). All battalion flight elements closed the (SNAKEPIT) staging area under cover of darkness for organization and preparation for combat.

b. The first lift departed the staging area at 0710 hours and was enroute to the landing zone during the tactical air preparation and landed in the LZ immediately following the armed helicopter prestrike. Tactical Air and the armed helicopter prestrike was very effective and the landing was unopposed; however light small arms and automatic weapons fire was received 500 meters southwest of the landing zone. Suppressive fire by the armed helicopters silenced the hostile fire. During the second landing, only single shot small arms fire was received and during successive lifts no hostile fire was reported. After the second landing by the assault helicopters the CH-47 medium helicopters began to reposition the 319th artillery battalion, New Zealand (KIWI) artillery and other supporting personnel and equipment. At 1143 hours the final lift was completed and the battalion flight elements were released at 1259 hours. Normal scheduled III Corps missions were performed by battalion aircraft. A Company 82d Aviation Battalion provided direct aviation support for resupply of food and equipment during the operation.

c. On the morning of 11 March 66 final briefing was again held at the SNAKEPIT. The same task organization was committed and two lifts were required to lift the 2/503rd Airborne Infantry into LZ # 8, coordinates YT 108995. The landing zone had previously been secured by the 1/RAR, therefore no prestrike was required by either tac air or armed helicopters; however tac air and armed helicopters provided air cap and were immediately available. No hostile fire was encountered during the lift. The landing zone was smaller than expected and flight elements were required to be broken down into flight's of three aircraft each. No problems were encountered and only minor changes to the time schedule were made. During the return to the SNAKEPIT flight elements participated in offensive firing along the border of the 173rd TAOR. Normal scheduled III Corps missions were performed for the remainder of the day.

d. The Command and Control helicopter carried the ground command group and air mission commander and directed and coordinated the airmovement.

e. The 197th Aviation Company provided armed helicopters for flight route escort, LZ reconnaissance and LZ marking.

f. The 74th Aviation provided one O-1F aircraft for radio relay, aerial surveillance and weather advisory during the air movement.

SEQUENCE OF EVENTS

<u>ITEM</u>	<u>TIME</u>	<u>ACTIVITY</u>
1.	090600 Mar 66	145th Avn Bn CP opened BH
2.	0615	145th Avn Bn (Reinf) closed Snakepit
3.	0615	Final Briefing
4.	0700-0725	Tac Air prep of LZ # 12
5.	0705	1/RAR loaded, Snakepit
6.	0710	145th Avn Bn departed Snakepit
7.	0725-0730	Armed Hcptr prestruck, Recon'd and marked LZ # 12
8.	0730	1st aslt landed LZ # 12
9.	0745-1500	CH-47 moved 319th arty Bn (Reinf), 101st arty and other support
10.	0750-0753	145th Avn Bn (Reinf) arrived Snakepit loaded, and departed
11.	0813	2nd Aslt landed LZ # 12
12.	0834	145th Avn Bn (Reinf) Snakepit shutdown and loaded equipment, refueled
13.	0849	145th Avn Bn (Reinf) departed Snakepit
14.	0909	3rd aslt landed w/equipment
15.	0929	145th Avn Bn arrived Snakepit
16.	0949	A/82d landed, command group LZ # 12
17.	1009	A/82d arrived Snakepit, refueled
18.	1035-1040	145th Avn Bn (Reinf) loaded 1/503rd and departed Snakepit
19.	1100	4th aslt landed LZ # 12
20.	1120-1123	145th Avn Bn (Reinf) arrived Snakepit loaded and departed
21.	1143	5th aslt landed LZ # 12
22.	1204	145th Avn Bn (Reinf) flight elements released on order
23.	1500	CH-47's released on order
1.	110630 Mar 66	145th Avn Bn CP opened Snakepit
2.	0645	145th Avn Bn (Reinf) closed Snakepit
3.	0700	Final Briefing
4.	0730-0740	Deceptive arty prep'd LZ # 45
5.	0740-0755	Deceptive air struck LZ # 45
6.	0740	145th Avn Bn (Reinf) departed Snakepit
7.	0800	1st aslt landed LZ #8
8.	0844	2nd aslt landed LZ #8
9.	0900	145th Avn Bn (Reinf) flight elements released on order

g. In support of the 145th Aviation Battalion completed 476 helicopter flying hours and 1145 combat sorties.

4. ADMINISTRATION and LOGISTICS:

(9 March 1966)

a. Supply:

(1) Refueling was conducted in the Snakepit for all troop carriers and armed helicopters.

(2) Refueling of the eight (8) CH-47's was conducted at the west end of the Bien Hoa runway from 0715 to 1015 hours, utilizing one 5,000 gallon tanker from the 506th QM Company.

(3) Seventeen 1200 gallon tankers were utilized in support of the operation, and a total of 20,000 gallons of JP/4 fuel were required for the 88 helicopters.

b. Maintenance:

(1) A maintenance representative was located at the Snakepit throughout the operation.

(2) UH-1B, SN 12918, from A/82d Aviation Battalion received a small arms round in the pilots door frame causing minor damage. Aircraft continued with its mission.

c. Medical:

(1) The battalion surgeon and 93rd Medical Detachment surgeon were located at the Snakepit.

(2) 93rd Medical Detachment provided one aidman and ambulance on standby in the Snakepit.

(3) No casualties were reported or treated as a result of the operation.

(11 March 1966)

a. Supply:

(1) Refueling was conducted at the Snakepit with aircraft being refueled upon closing at Bien Hoa and at the conclusion of the operation.

(2) UH-1D, SN 64-13714, from the 118th Aviation Company failed to start for the first lift. Battery was low and replaced. Aircraft started and participated in the second lift.

c. Medical:

- (1) Battalion Surgeon was located at the Snakepit throughout the operation .
- (2) 93rd Medical Detachment provided one aidman and ambulance on standby.
- (3) No casualties were reported or treated as a result of the operation.

5. COMMENTS and RECOMMENDATIONS:

a. During the air movement, at approximately 0755 hours, unannounced artillery or mortar fire from the 1st Brigade 1st (US) Infantry artillery base (NEVADA) began falling extremely close to the previously closed flight route. The S-3 145th Aviation Battalion immediately called for a cease fire in order for the combat assault to be executed on schedule. Unannounced artillery fire within previously cleared flight corridors continues to be a hazard to flight elements and disrupts the scheduled air movement. Assault elements must be admitted into the landing zone immediately following the USAF and armed helicopters landing zone preparation and prestrike in order to take advantage of the dazed and disorganized enemy defenders. Each airmobile operation conducted by this battalion has flight route clearance through 1st (US) Infantry Division FSCC, to and from the landing zone; however upon contact by the command and control helicopter with the local FSCC, no flight corridor has been requested through their area of influence. It is recommended that command emphasis be placed on this problem area and that II, FFV coordinate with each artillery controlling agency within the flight corridor before confirming the flight route.

b. Communications interference on assigned battalion command frequencies continue to present a problem. Interference on the battalion pathfinder frequency was experienced throughout the operation. The station call sign utilizing this assigned frequency was Pokey Steamer. Interference on command frequencies is unacceptable. A major effort by the appropriate headquarters should be made to insure the command frequencies are assigned on a sole user basis.

c. Noteworthy was the well organized and rapid clearing of the landing zone of the large equipment and numerous supplies which the CH-47's landed in the LZ in between the air lift of combat troops. This aggressive securing of the landing zone and rapid deployment of men and equipment, insured the smooth continuous flow of combat troops into the operational area.

d. This operation was conducted in highly professional and efficient manner.

Distribution:

Special

Horst K. Joost
HORST K. JOOST
Lt. Col. Infantry
Commanding

HEADQUARTERS
145TH AVIATION BATTALION
APO San Francisco 96227

AVAW-PC

24 March 1966

SUBJECT: After Action Report, 145th Aviation Battalion Operation 18-66AA, 18-66 BB
and 18-66CC (extraction Phases) 210725 March 1966, 211400, March 1966
and 221125 March 1966

TO: Distribution Special

1. TASK ORGANIZATION:

a. Battalion Headquarters:

145th Aviation Battalion Command and Control Helicopter
145th Aviation Battalion Armed Helicopters (-)
74th Aviation Company (-)

b. 1st Flight Element:

18-66AA and 18-66BB

18-66CC

118th Aviation Company
10 UH-1D Helicopters
1 UH-1B (Maint) Helicopter

68th Aviation Company
10 UH-1D Helicopters
1 UH-1B (Maint) Helicopter

c. 2nd Flight Element:

A Company 501st Aviation Battalion
10 UH-1D Helicopters
1 UH-1D (Maint) Helicopter

118th Aviation Company
10 UH-1D Helicopters
1 UH-1B (Maint) Helicopter

d. 3rd Flight Element:

68th Aviation Company
10 UH-1D Helicopter
1 UH-1B (Maint) Helicopter

A Company, 82nd Aviation Bn
10 UH-1D Helicopters
1 UH-1B (Maint) Helicopter

e. 4th Flight Element:

116th Aviation Company
10 UH-1D Helicopters
1 UH-1B (Maint) Helicopter

f. Armed Elements:

68th Aviation Company
5 UH-1B (Armed) Helicopters

116th Aviation Company
2 UH-1B (Armed) Helicopters

118th Aviation Company
4 UH-1B (Armed) Helicopters

A Company 82nd Aviation Battalion
3 UH-1B (Armed) Helicopters

A Company 501st Aviation Battalion
3 UH-1B (Armed) Helicopters

g. Support Elements:

145th Aviation Battalion Communications Section
145th Aviation Battalion Maintenance Section
145th Aviation Battalion Pathfinder Detachment
145th Aviation Battalion POL Section
56th Transportation Company (Maint)(-)
57th Medical Detachment (Air Amb)(-)

2. MISSION: The 145th Aviation Battalion (Reinf) provided troop carriers, armed helicopters and command and control aircraft for the 173rd (US) Airborne Brigade Airmobile assaults (1/RAR, 1/503) into landing zone # 12 (coordinates YT 082425) beginning 090730 March 1966; and landing zone # 8 beginning 110800 March 1966; there after provided logistical support as required and necessary airmobile force for extraction on 21st and 22nd March 66.

3. SUMMARY OF OPERATIONS:

a. All Battalion flight elements closed SNAKEPIT staging area by 210725 and final briefing for the extraction phase of operation SILVER CITY was held at 210730 March 1966. The first lift departed for LZ 102 at 210840 preceded by 145th Aviation Battalion Command and Control and Pathfinder elements. The first extraction phase included six lifts in which 1186 troops of the 1st and 2nd Battalions 503rd Infantry were helilifted out of War Zone D. No enemy fire was received during this phase. Another extraction operation for III (ARVN) Corps, from War Zone D, was initiated on very short notice at this point. This operation began with a final briefing in the SNAKEPIT staging area at 211400 March 1966. At 211513 145th Aviation Battalion departed the SNAKEPIT for LZ TERI. A force of 300 CIDG troops was extracted in one lift from LZ TERI in an operation that was executed exactly as planned. No enemy fire was received and all flight elements returned to the SNAKEPIT area and were released. The final phase of SILVER CITY began with 145th Aviation Battalion closing the SNAKEPIT area at 221125 March 1966 with final briefing at 211130 March 1966. This operation was planned with a flexible takeoff time built in; the actual takeoff time was advanced 30 minutes from the planned time and the 145th Aviation Battalion was airborne at 211310 enroute LZ 12.

The LZ was sub-divided into three pickup sites to support the tactical plan. This call for close coordination between all flight elements, 145th Aviation Battalion Command and Control aircraft and the 145th Aviation Battalion Pathfinder Detachment. This coordination handled in an outstanding manner by all elements which insured smooth and positive execution of the critical pickup phase of this operation. A total of 690 troops from the First Battalion Royal Australian Regiment with all organic heavy weapons, two platoons of 4.2 mortars and six engineer (ICR) assault boats were extracted from LZ 12 in four lifts. No enemy fire was received by the troop carriers; however, armed helicopters received small arms and automatic weapons fire at (coord YT 122421), 4 Km east of LZ 12. This fire was returned quickly and the enemy position was neutralized. Offensive fires were utilized by the last flight element one Km south of LZ 12. After a visual reconnaissance of the LZ to insure all troops had been extracted, the armed escort platoons interdicted by fire the avenues of approach on the east side of the river.

b. All 145th Aviation Battalion (Reinf) armed helicopters (-197th Aviation Company) were detained under battalion control during these extraction operations, except for three platoons which were placed in direct support of ground elements in phase three. This airborne firepower was utilized in lieu of normal artillery which was not available during this critical phase. Armed elements under battalion control performed armed escort, flight route reconnaissance and continuous armed overhead cover of the operational area.

c. The 74th Aviation Company provided one O-1F aircraft for radio relay, aerial surveillance and weather advisory during the air movement.

SEQUENCE OF EVENTS

210725 March 66	145th Aviation Battalion closed SNAKEPIT
0730	Final Briefing
0840	145th Aviation Battalion (Reinf) departed SNAKEPIT
0900	1st lift, arrived, loaded and departed LZ 102
0923	145th Aviation Battalion, arrived unloaded and departed SNAKEPIT
0945	2nd lift, arrived, loaded, and departed LZ 102
1008	145th Aviation Battalion arrived, unloaded and departed SNAKEPIT
1030	3rd lift arrived, loaded and departed LZ 102
1053	145th Aviation Battalion arrived SNAKEPIT and refueled to 1200 lbs.
1130	145th Aviation Battalion departed SNAKEPIT
1150	4th lift arrived, loaded and departed LZ 102
1213	145th Aviation Battalion arrived, unloaded and departed SNAKEPIT
1235	5th lift arrived, loaded and departed LZ 102
1255	145th Aviation Battalion arrived, unloaded and refueled to 1000 lbs.
1400	Final briefing for second phase of extraction
1500	145th Aviation Battalion Command and Control aircraft reported to Bien Hoa (III Corps) soccer field
1530	145th Aviation Battalion arrived, loaded and departed LZ TERI

1550	145th Aviation Battalion arrived, unloaded and was released at the SNAKEPIT
221125 Mar 66	145th Aviation Battalion closed SNAKEPIT
1130	Final briefing phase three.
1310	1st lift departed SNAKEPIT
1330	1st lift arrived, loaded and departed LZ 12A
1352	2nd lift departed SNAKEPIT
1412	2nd lift arrived, loaded and departed LZ 12A
1433	2nd lift arrived SNAKEPIT and refueled (1200 lbs)
1510	3rd lift departed SNAKEPIT
1528	3rd lift arrived, loaded and departed LZs 12B and C.
1546	4th lift departed SNAKEPIT
1604	4th lift arrived, loaded and departed LZs 12B and C.
1622	145th Aviation Battalion closed SNAKEPIT, unloaded and was released.

d. In support of this operation the 145th Aviation Battalion (Reinf) provided one O-1F aircraft and 64 helicopters flying 248 hours and 796 combat sorties. There were no aircraft hit or friendly casualties.

4. ADMINISTRATION AND LOGISTICS

a. Supply:

(1) Refueling of the troop carriers and armed helicopters was accomplished at the Snakepit staging area with fourteen (14) 1200 gal. tankers.

(2) Eight (8) CH-47 helicopters were provided fuel throughout the operation on 22 March 66.

b. Maintenance: No maintenance problems or combat damage were encountered by the flight elements during the operation.

c. Medical: No casualties were reported or treated as result of the operation.

5. COMMENTS AND RECOMMENDATIONS:

a. During the first extraction phase at 210915 March 1966 a U6A type aircraft overflow the area of operations making two passes at 3000 feet MSL from west to east. Unauthorized aircraft should be restricted from areas of operations as overflights create a very hazardous condition.

b. During the second phase the artillery base (NEVADA) did not receive the flight route clearance from AACC. This could have been a very serious error had not the 145th Aviation Battalion Command and Control double checked for proper clearance. Recommend AACC revise methods of route clearance to provide additional cross checks of units under their control.

c. Armed helicopters in direct support of ground units during phase three were not kept informed of mortar fire in their area. Ground elements must be aware of their obligations to keep attached aviation elements fully informed of the tactical situation at all times. Only by monitoring both ground and air frequencies constantly was the 145th Aviation Battalion command group able to keep it's armed aircraft informed as to friendly mortar fires.

d. During the critical, final phases the last extraction, the ground commander asked that the flight elements delay for ten minutes. This request was not received by the air mission commander until his lead element was on low short final to LZ 12 B&C. This created a dangerous situation in that a go-around was made over hostile territory at very low level. In future operations it is strongly recommended that the ground commander plan his movements and make them known to the air mission commander far enough in advance to avoid last second changes in LZ time.

e. During the planning stages for future operations in which a flexible time schedule is utilized both the air mission commander and the ground commander should agree on time slippages and speed ups as needed.

f. Troops should again be cautioned against the practice of jumping from helicopters prior to touch down.

g. The airmobile force commander should relay all changes in flight composition and numbers of helicopters per element to his ground unit commander for load planning. The air mission commander will also advise his pathfinders of these changes.

h. During the final phases of extraction operations the ground commander may plan for the fastest possible turn around times as the Aviation elements have the necessary flexibility to evacuate troops to closer alternate LZ's and substantially reduce turn around times.

i. The number of helicopters normally available to this unit for troop lift dictates that future planning be made on the basis of three lifts per battalion size ground unit.

j. In future extraction operations executed by the 145th Aviation Battalion it will become standard operating procedure for armed helicopters to overfly the last LZ after the final lift is clear and search for friendly personnel and equipment. After this sweep is completed these armed elements will interdict by use of offensive fires all avenues of approach to the LZ to hamper immediate hostile occupation of the area.

Distribution :
Special

HORST K. JOOST
Lt Col Infantry
Commanding

HEADQUARTERS
145TH AVIATION BATTALION
APO San Francisco 96227

AVAW-FC

28 March 1966

SUBJECT: After Action Report; 145th Aviation Battalion Operation
20-66, 141300 March 1966

TO: See Distribution

1. TASK ORGANIZATION:

a. Battalion Headquarters:

145th Aviation Battalion Command and Control Helicopter
74th Aviation Company (-)
197th Aviation Company (-)

b. 1st Flight Element; A Company, 501st Aviation Battalion (AML)

Attached: 3 UH-1D helicopters from 116th Aviation Company (AML)
12 UH-1D helicopters
5 UH-1B (Armed) helicopters
1 UH-1B (Maint) helicopter

c. 2nd Flight Element: 68th Aviation Company (AML)

Attached: 2 UH-1D helicopters from 116th Aviation Company (AML):
12 UH-1D helicopters
5 UH-1B (Armed) helicopters
1 UH-1B (Maint) helicopter

d. 3rd Flight Element: 116th Aviation Company (AML):

12 UH-1D helicopters
5 UH-1B (Armed) helicopters
1 UH-1B (Maint) helicopter

e. 4th Flight Element: 118th Aviation Company (AML):

Attached: 2 UH-1D helicopters from 116th Aviation Company (AML):
12 UH-1D helicopters
5 UH-1B (Armed) helicopters
1 UH-1B (Maint) helicopter

2. MISSION:

The 145th Aviation Battalion (Reinf) provided the necessary troop carriers, armed helicopters and control aircraft in support of the 25th ARVN Division Airmobile assault into LZ MIKE, (coordinates XS 521979) and LZ ZULU (coordinates XS 536892) D Day and LZ NAN, (coordinates XS 509945) on D Day + 1.

82

3. SUMMARY of OPERATION:

a. The 145th Aviation Battalion Commander and Staff assembled at the forward command post (SNAKEPIT) for final briefing of flight crews and organization for combat 141115 March 1966.

b. The 145th Aviation Battalion (Reinf) departed the SNAKEPIT at 1206 hours enroute to the troop loading sites. Two sites were selected, Cu Chi and Tram Vang; the first two flight elements landed Cu Chi and loaded troops while the third and fourth flight elements continued to Tram Vang for troop loading. A rendezvous in flight over a preselected air control point was executed and the combat assault conducted into LZ MIKE, USAF Tac Air provided landing zone preparation and the armed helicopters provided the final prestrike. The lead flight element's organic armed platoon provided suppressive fire during the assault landing. Only light small arms fire was received by the flight elements during the 1st assault. Troops for the second assault were also located at different sites, Tan An and Ben Luc. The first, second, and third flight elements proceeded to Tan An and the fourth flight element loaded troops at Ben Luc. A rendezvous in flight was executed and the second combat assault into landing zone ZULU was made, USAF tactical air and the armed helicopters provided LZ preparation and only light small arms fire was received. Upon departure from the landing zone the battalion conducted offensive firing to seal off the Viet Cong escape routes. The battalion was released except for Company A, 501st Aviation Battalion which conducted one more assault into the operational area with the command group and the remaining ground force elements which were at Ben Luc. During this portion of the operation a Viet Cong radio station was discovered and 4 troop carriers from A Company 501st Aviation Battalion and one light fire team conducted a raid, air lifting 35 troops into the area. The station was not located. One fortified gun emplacement was destroyed by rocket fire from an armed helicopter.

c. At 150715 March 1966 the 145th Aviation Battalion (Reinf) assembled in the SNAKEPIT for final briefing of flight crews to continue in support of the 25th ARVN Division. Flight elements departed the SNAKEPIT at 0813 hours enroute to Cu Chi and an intermediate troop loading site. The battalion conducted simultaneous loading and a rendezvous enroute to the landing zone. The assault landing was complete at 0904 hours and no hostile fire was received. Upon completion of this assault the battalion flight elements were released to perform normal scheduled III Corps command and liaison, administrative and logistical support.

d. The 74th Aviation Company provided one O-1F for aerial surveillance, radio relay and weather advisory.

e. The 197th Aviation Company (Armed) conducted flight route and surrounding area reconnaissance and LZ prestrikes, marking and continuous over head cover for the ground force. During the over head cover phase of the operation a camouflaged Viet Cong position was located, and ground troops were alerted. Receiving no response from the ARVN force on the ground the position was engaged by the armed helicopters and destroyed.

f. In support of the air movement phase the battalion committed one O-1F airplane and 81 helicopters, flying a total of 181.4 hours and 442 combat sorties. A total of 1140 troops were lifted from four pick up sites into the operational area. The Battalion Command and Control Helicopter was used by the 25th ARVN Division Command Group and the Air Mission Commander for coordination of TAC AIR, Artillery, and other supporting elements during the air movement of the Division.

SEQUENCE OF EVENTS

<u>ITEM</u>	<u>TIME</u>	<u>ACTIVITY</u>
1.	141100 Mar 66	145th Avn Bn Closed BH
2.	1115	Final Briefing
3.	1145	Patherfinder Trang Bang and Trom Vang; thereafter reported to Ben Luc and Tan An
4.	1206	145th Avn Bn (Reinf) departed BH
5.	1220	C&C helicopter reported DH
6.	1230-1255	Tac Air prep'd LZ MIKE
7.	1237	1st & 2nd flight elements landed & loaded LZ BLUE
8.	1240	1st & 2nd flight elements departed LZ BLUE
9.	1242	3rd & 4th flight elements arrived LZ BLACK
10.	1245	3rd & 4th flight elements departed LZ BLACK
11.	1247	1st & 2nd flight elements arrived ACP AIREDALE
12.	1249	3rd & 4th flight elements rendezvoused ACP AIREDALE
13.	1255-1300	Armed Hcptr prestruck & marked LZ MIKE
14.	1300	1st assault landed LZ MIKE
15.	1300-1325	Tac Air prep'd LZ ZULU
16.	1315	4th flight element arrived LZ GREEN
17.	1320	1st, 2nd, 3rd flight elements arrived and loaded, LZ RED
18.	1323	1st, 2nd, flight element departed LZ RED
19.	1324	4th flight element departed LZ GREEN
20.	1325-1338	Armed Hcptr prestruck & marked LZ ZULU
21.	1334	Flight elements rendezvoused/ ACP SPARROW
22.	1339	2nd aslt landed LZ ZULU
23.	1348	Bn flight elements released on order except A Co, 501st Avn Bn
24.	1349	145th Avn Bn conducted offensive fire on order
25.	1354-1357	A Co, 501st Avn Bn arrived LZ GREEN, loaded & departed
26.	1413	3rd Aslt landed LZ ZULU
27.	1422	A Co, 501st Avn Bn arrived DH refueled, & released to perform scheduled missions.

4. ADMINISTRATION and LOGISTICS:

a. Supply:

(1) The assistant S-4 and POL section with six fuel pumping units departed Bien Hoa at 0740 hours for Duc Hoa and prepared to support the operation. Coordination had been effected and ten 2½ ton trucks loaded with 55 gallon drums of JP/4 fuel was provided by the G-4 advisor, 25th ARVN Division. A total of 8,000 gallons of JP/4 fuel was used at Duc Hoa and 2,500 gallons at Bien Hoa.

(2) 500 rounds of 40 MM ammunition was transported to Duc Hoa in support of the operation.

b. Maintenance:

(1) A maintenance representative was located at the SNAKEPIT throughout the operation.

(2) UH-1D, SN 64-13868, 116th Aviation Company, did not make the lift due to an electrical short in the fuel booster pump. Aircraft was taken to 573rd Maintenance Detachment for repair.

c. Medical:

(1) The battalion surgeon was airborne throughout the operation in the command and control helicopter.

(2) 93rd Medical Detachment provided an ambulance and aidman on standby in the SNAKEPIT throughout the operation.

(3) A gunner from A Company 501st Aviation Battalion, armed platoon sustained an abrasive injury on the left forearm during a firing pass. The injury was treated by the battalion surgeon at Duc Hoa during refueling and aircraft and crew continued with the mission.

5. COMMENTS and RECOMMENDATIONS:

a. Unannounced and uncontrolled artillery fire continue to present a major problem, particularly when staging area or airfields are ringed with artillery. In addition, the central controlling agency for artillery, Fire Support Coordination Center, at 1st (US) Infantry Division and III Corps TOC is informed of impending operations by this battalion and a flight route corridor is forwarded to FSCC, and III Corps TOC for coordination with supporting artillery units. Confirmation is always received prior to the air movement. The command and control helicopter arrived in the area and requested confirmation of flight route clearance. The local FSCC was not aware of the flight route.

b. Recommend that command emphasis be placed on the positive control of artillery fires and that local artillery controlling agencies be notified through 1st US Infantry Division FSCC of Air Movement within their tactical area of responsibility.

Distribution:
Special

Horst K. Joost
HORST K. JOOST
Lt Col Infantry
Commanding

85

HEADQUARTERS
145TH AVIATION BATTALION
APO San Francisco 96227

AVAW-FC

5 April 1966

SUBJECT: After Action Report of 145th Aviation Battalion Operation
22-66, 5 April 1966

TO: Distribution Special

1. TASK ORGANIZATION:

a. Battalion Headquarters:

145th Aviation Battalion Command and Control Helicopter
74th Aviation Company (-)
197th Aviation Company (-)

b. 1st Flight Element: A Company 501st Aviation Battalion

8 UH-1D helicopters
1 UH-1B helicopter

c. 2nd Flight Element: 68th Aviation Company (AML)

10 UH-1D helicopters
3 UH-1B (armed) helicopters
1 UH-1B (maint) helicopter

d. 3rd Flight Element: 118th Aviation Company (AML)

9 UH-1D helicopters
3 UH-1B (armed) helicopters
1 UH-1B (maint) helicopter

e. Support Element:

145th Aviation Battalion Communications Section
145th Aviation Battalion Maintenance Section
145th Aviation Battalion Pathfinder Section
145th Aviation Battalion POL Section
56th Transportation Company (-)
57th Medical Detachment (Air AMB)(-)

2. MISSION: The 145th Aviation Battalion Provided troop carriers, armed helicopters, radio relay and command and control aircraft for Eagle Airborne Assault into LZ's Scarlet, (coordinates XT 029544) and Red (coordinates XT 011585), 050800 April 1966 and conducted extractions on order from LZ's IRON and PURPLE for repositioning into LZ GREEN.

3. SUMMARY OF OPERATIONS:

a. Battalion combat and support elements (- 68th Aviation Company) closed the Bien Hoa (SNAKEPIT) staging area 050440 April 1966 for final briefing and organization for combat.

b. Flight Elements departed Bien Hoa enroute to the troop loading site at Tay Ninh at 0522. The 145th Aviation Battalion Pathfinder Detachment (-) preceded the lift elements and prepared the troops for immediate loading upon the arrival of the troop carriers. Tay Ninh airfield was used as a loading zone and no difficulty in loading was experienced.

c. The initial airmobile assault into LZ Scarlet was delayed for twelve minutes because friendly artillery was not in position to support. After this lift was completed the troop carriers returned to Tay Ninh, refueled and were joined by the 68th aviation company.

d. At 0746 145th Aviation Battalion departed Tay Ninh airfield enroute to LZ Red (North). Prior to the armed helicopter prestrike and marking of LZ Red (North) two helicopters dropped CS gas, followed by another helicopter using the "MAD" system in the offensive fire zone north of the LZ. Both assaults in LZ Red (North) went as planned on scheduled and enemy fire received one and one half kilometers north east of the LZ was ineffective. Each flight element on departing LZ Red conducted offensive fires from armed ships and slick door guns covering the barrier created by the CS. This resulted in 3 KBA and 3 WBA and an estimated 9 KBA in the area immediately south of the barrier. The CIDG forces did not advance into or North of the barrier which was also covered by offensive fire. Results in this area are unknown, but estimated to be twice the confirmed results. The third assault landing was changed, by the ground commander, from LZ Red (South) to LZ Red (North & South).

e. Phase III of the operation was cancelled because ground elements were in close contact with enemy forces. During this time frame the CIDG troops were supported both by armed and dustoff (Aerial Ambulance) helicopters. At 1145 a slick evacuated four ARVN WIA's from the vicinity of LZ Brown. The dustoff aircraft participating in the evacuation was fired upon and hit by an automatic weapon; the crew chief returned the fire killing the Viet Cong gunner. at 1540 four more ARVN WIA's were evacuated from LZ Brown by gun ships.

f. At 1705 the final phase of the day's operation began with the 145th Aviation Battalion lifting 798 CIDG troops in three lifts, low level from LZs Brown to LZ Green. One helicopter from the 68th Aviation Company crashed on take off from LZ Brown with no serious injuries to crew members. By 1805 this helicopter had been recovered by the 56th Transportation Company. LZ Green was prestruck by organic gun ships with only light small arms fire received to the north and north east of the LZ.

g. The 74th Aviation Company provided one O-1F for radio relay, weather, advisory and surveillance throughout the operation.

h. The 197th Aviation Company provided 5 UH-1B (armed) helicopters and conducted flight route and surrounding area reconnaissance, landing zone marking, prestrike and provided two helicopters for CS gas dispensing. One UH-1D helicopter from the 118th Aviation Company was attached for dropping 81 mm mortar rounds equipped with bomb fuzes following the gas strike.

SEQUENCE OF EVENTS

TIME	ACTIVITY
0440	145th Avn Bn (-) closed SNAKEPIT
0445	Final Briefing
0522	A/501st, 118th, and 197th departed SNAKEPIT
0600	Flight elements arrived Tay Ninh
0610-0625	Artillery preparation LZ Scarlet
0618	Flight elements loaded and departed Tay Ninh
0625-0630	Armed helicopters marked and prestruck LZ Scarlet
0630	Flight elements landed LZ Scarlet
0645	Flight elements arrived Tay Ninh (refueled) (Note: 1200 lbs UH-1D)
0700	68th Avn Co arrived Tay Ninh (refueled) (Note: 1200 lbs UH-1D)
0710-0755	Tac Air prep LZ Red (North)
0746	145th Avn Bn departed Tay Ninh
0755-0800	Armed helicopter marked and prestruck LZ Red (North)
0755-0800	Operation "GAS" and "MAD"
0800	1st assault landed LZ Red (North)
0835	2nd assault landed LZ Red (North)
0910	3rd assault landed LZ Red (North & South)
0930	145th Avn Bn arrived Tay Ninh (refueled) stood-by for further operations
1705	145th Avn Bn arrived LZs Brown and Purple (2 lifts LZ Purple, three lifts LZ Brown) into LZ Green
1820	145th Avn Bn Elements were released.

In support of this operation the 145th Aviation Battalion provided one O-1F airplane and 39 helicopters flying 114 hours and 223 combat sorties, carrying 1019 troops in a multi lift operation. Four aircraft were hit by ground fire, however there were no aircrew casualties.

4. ADMINISTRATION AND LOGISTICS:

a. Supply:

(1) Battalion S-4 coordinated with the S-4 of Det 32, Tay Ninh for six (6) 2½ ton vehicles to be loaded with fifteen (15) drums of JP/4.

(2) The 118th Aviation Company provided 3, UH-1D to transport six (6) fuel pumps to Tay Ninh.

(3) A total of 46 UH-1's and 5 CH-47's were refueled for a consumption of 13,500 gallons of JP/4.

b. Maintenance:

(1) A battalion maintenance representative was located at the battalion forward command post throughout the operation.

(2) The following aircraft from the 68th Aviation Company received damages as indicated:

(a) UH-1D, SN 64-14087, received a small arms round through the radio compartment rendering several radios inoperative. Aircraft continued with the operation.

(b) UH-1D, SN 64-13798, crashed into trees departing the landing zone. Aircraft was a total loss. Aircraft was evacuated to Vung Tau.

(3) UH-1D, SN 63-8597 from the 118th Aviation Company received small arms rounds through the left side of aircraft causing minor damage. Aircraft continued with the mission.

(4) UH-1B, SN 63-8658, from the 57th Medical Detachment, received a small arms round through the bottom of aircraft under pilot seat. No major damage was caused and aircraft continued with the mission.

c. Medical:

(1) Aid Station was provided by the 430th Medical Detachment and transported to battalion forward command post by the 68th Avn Co.

(2) No US casualties were reported as a result of the operation.

5. COMMENTS AND RECOMMENDATIONS:

a. At 051040 artillery fired from the LZ Scarlet area into the LZ Red (North) objective area while Saber elements were airborne in that area. No coordination was made with either the command and control element or Saber flight leader. Artillery commanders at all levels must be made aware of their responsibilities to supporting Aviation Elements, and coordination must be made down to the flight element level when both artillery and armed helicopter support are utilized.

b. The aircraft utilized in the tactical air prestrike were changed from F-100s to A-1Es without notification to the air mission commander. The change of bomb load from 500lb general purpose and CBUs to white phosphorus caused smoke obscuration of both LZ Red North and the offensive fire zone.

c. The air mobile force commander must be designated in the order for the ground tactical plan. A clearly defined chain of command is necessary for a smoothly controlled operation.

d. Supported unit commanders must remain in constant communication with the air mission commander to insure that timely decisions are made to insure successful operations.

e. The locations of enemy forces firing on flight elements were passed to ground commanders for action and information. Little or no action was taken by ground commanders to eliminate the source of this fire or to engage the enemy.

f. The aerial photographs requested from IIFV for this operation were unsatisfactory. The aerial photographs recieved did not cover the area requested and the key which located the area of the aerial photos was different from the aerial photos recieved.

g. The G-3, II F Forces V observed the entire airmobile operation from the command and control aircraft.

h. CG Aviation Brigade was briefed by the 145th Aviation Battalion Commander at 051500, he than participated in the final phase of the operation.



HORST K. JOOST
Lt Col Infantry
Commanding

HEADQUARTERS
145TH AVIATION BATTALION
APO San Francisco 96307

AVAW-PC

19 January 1966

SUBJECT: After Action Report, Operation 1-66, 145th Aviation Battalion,
4 January 1966

TO: Commanding General, 1st Infantry Division, APO San Francisco 96345
Commanding Officer, 12th Aviation Group, APO San Francisco 96307
Senior Advisor, III ARVN Corps, APO San Francisco 96227

1. TASK ORGANIZATION:

a. Battalion Headquarters:

145th Aviation Battalion Command and Control Helicopter
197th Aviation Company (-)

b. 1st Flight Element: 68th Aviation Company:

11 UH-1D Helicopters
5 UH-1B (Armed) Helicopters
1 UH-1B (Maint) Helicopter

c. 2nd Flight Element: A Co, 501st Aviation Battalion:

11 UH-1D Helicopters
5 UH-1B (Armed) Helicopters
1 UH-1B (Maint) Helicopter

d. 3rd Flight Element: 118th Aviation Company:

11 UH-1D Helicopters
5 UH-1B (Armed) Helicopters
1 UH-1B (Maint) Helicopter

e. Support Element:

145th Aviation Battalion Communications Section
145th Aviation Battalion Maintenance Section
145th Aviation Battalion Pathfinder Detachment
56th Transportation Company (-)
57th Medical Detachment (Air Amb) (-)

2. MISSION: The 145th Aviation Battalion provided troop carrier, armed escort, and Command and Control aircraft for the 25th ARVN Division airmobile assault with two battalions (3/49 and 1/49) into LZ MIKE (coordinates XT 407179) and LZ GOLF (coordinates KT 423182), 7 Km southeast of Go Dau Ha, RVN, beginning 041000 January 1966; thereafter, provided continuous armed overhead cover and close support for ground operations. Flight elements were then released to perform scheduled III Corps missions subject to a two hour recall to lift a reserve reaction force.

3. SUMMARY OF OPERATION:

a. Commanders, Staff, and supporting elements assembled at the 145th Aviation Battalion Forward Command Post in Bien Hoa, 040830 January 1966, for final briefing. Flight elements of the battalion were assembled, given final instructions, and organized for combat. At 0925 hours the flight elements departed Bien Hoa enroute to the initial troop loading site at Cu Chi.

b. At the Cu Chi loading site the battalion flight elements encountered a flight of VNAF CH-47's (10) which had arrived in the loading site unannounced. The VNAF CH-47's were scheduled to airlift the 49th ARVN Regiment Command Post group into the operational area fifteen minutes after the initial combat assault had been completed. Due to the efforts of the 25th ARVN Division Commanding General (flying in the Command and Control helicopter) and the 145th Aviation Battalion Pathfinder, the VNAF CH-47 flight was repositioned in order to permit the orbiting assault troop carriers to land in the loading site. Loading was extremely slow due to:

- (1) Non availability of troops in the loading area.
- (2) Limited Pathfinder Personnel.
- (3) The American advisor with the ARVN troop unit showed little initiative in organizing ground elements for loading.

c. The 145th Aviation Battalion flight elements departed the loading site at Cu Chi five minutes behind schedule due to the encountered delays; however, this time was regained during flight enroute to the objective area. The artillery and tactical air prestrike of the landing zone was extremely good and well coordinated from the Command and Control helicopter. Armed helicopters of the 197th Aviation Company received small arms fire during their reconnaissance of the LZ and returned suppressive fire. The initial assault landing in LZ MIKE was relatively unopposed; however, each flight element received small arms fire in the vicinity of the LZ and during departure. The second combat assault was made from a loading site at TRANG BANG into LZ GOLF. Landing Zone GOLF was adjusted approximately 50 meters south and east from a wet marshy area to firmer ground by the Command and Control helicopter. No fire was received during the second assault landing. Upon completion of the second assault, battalion elements were released to home station for organization and preparation to continue scheduled III Corps missions.

d. 197th Aviation Company performed flight route and LZ reconnaissance, marking and prestrike of the landing zone and continuous overhead cover for the ground operation.

e. The 145th Aviation Battalion Command and Control helicopter effected the necessary coordination and control of flight elements, tactical air strikes, and other supporting fires throughout the operation.

f. Sixty-four helicopters were committed by the 145th Aviation Battalion in support of the operation. A total of 320 sorties and 118 flying hours were flown. No aircraft received hits or were damaged.

SEQUENCE OF EVENTS

040815 Jan 66	145th Avn Bn closed Bien Hoa
0830	Final Briefing at Bien Hoa
0925-0955	Tac Air preparation LZ MIKE
0925	145th Avn Bn departed Bien Hoa
0942	145th Avn Bn arrived Cu Chi, loaded troops and departed
0955-1000	Armed helicopters prestrike LZ MIKE
1000	1st Assault Landing LZ MIKE
1005-1030	Tac Air preparation LZ GOLF
1010-1015	145th Avn Bn arrived Trang Bang, loaded troops and departed
1030-1035	Armed helicopters prestrike LZ GOLF
1035	2nd Assault Landed LZ GOLF
1100	145th Avn Bn released

4. ADMINISTRATION AND LOGISTICS:

a. Supply:

(1) Refueling was conducted at Bien Hoa with an initial top off. Armed aircraft refueled at Duc Hoa and used 5,050 gallons of JP/4.

(2) It was decided to maintain 2 men and pumping units at Duc Hoa for continuing operations.

b. Maintenance: No maintenance problems were reported.

c. Medical:

(1) The 93rd Medical Detachment ambulance was on standby at Bien Hoa (SHALPIT).

(2) The Battalion Surgeon was located at Bao Trai (173rd Airborne Brigade Clearing Station).

(3) No casualties were reported.

5. PROBLEMS ENCOUNTERED:

a. Troops were not cooperative or well organized in loading sites and caused unnecessary delay. Fortunately, the flight elements were able to regain the lost time and arrive in the landing zone close to supporting fires as planned.

b. The VNAF CH-47 flight was not well coordinated and nearly precluded the troop carriers from accomplishing their assigned mission on time.

6. RECOMMENDATIONS:

a. That supported units render maximum cooperation and assistance to the airmobile battalion pathfinder representatives during loading zone organization and operation.

b. That all aircraft assigned for a particular operation be placed under one air mission commander in order to comply with the principle of unity of command.

CHARLES M. HONOUR JR.
Lt Colonel Infantry
Commanding

HEADQUARTERS
145TH AVIATION BATTALION
APO San Francisco 96307

AVAM-FC

4 February 1966

SUBJECT: After Action Report, 145th Aviation Battalion Operation 3-66
7 January 1966

TO: Commanding General, 1st Infantry Division, APO San Francisco
96345
Commanding Officer, 12th Aviation Group, APO San Francisco
96307
Senior Advisor, III Corps, APO San Francisco 96227

1. TASK ORGANIZATION:

a. Battalion Headquarters:

145th Aviation Battalion Command and Control Helicopter
74th Aviation Company (-)
197th Aviation Company (-)

b. 1st Flight Element: A Company, 501st Aviation Battalion

10 UH-1D Helicopters
5 UH-1B (Armed) Helicopters
1 UH-1B (Maint) Helicopter

c. 2nd Flight Element: 68th Aviation Company

10 UH-1D Helicopters
5 UH-1B (Armed) Helicopters
1 UH-1B (Maint) Helicopter

d. 3rd Flight Element: 118th Aviation Company:

10 UH-1D Helicopters
5 UH-1B (Armed) Helicopters
1 UH-1B (Maint) Helicopter

e. Support Element:

145th Aviation Battalion Communications Section
145th Aviation Battalion Maintenance Section
145th Aviation Battalion Pathfinder Detachment
56th Transportation Company (-)
57th Medical Detachment (Air Amb) (-)

2. MISSION: The 145th Aviation Battalion (-) provided troop carriers, armed cover, and control aircraft for the 48th Regiment, 10th ARVN Division's airmobile assault with two Battalions (2/48 Inf and 3/48 Inf) from LZ ORANGE (An Loc) into Landing Zone RED (coordinates YT 896419) 15 Km northwest of Vo Dat beginning 070800 January 1966.

3. SUMMARY OF OPERATION:

a. The 145th Aviation Battalion (-) closed the 145th Aviation Battalion Forward staging area (SNAKEPIT) 070615 January 1966 under the cover of darkness for final briefing and organization for combat.

b. At 0713 hours the 145th Aviation Battalion (-) flight elements departed the SNAKEPIT enroute to LZ ORANGE (An Loc) the troop staging area. Flight elements departed LZ ORANGE at 0730 hours enroute to the landing zone. The first assault landing was completed at 0800 hours with flight elements landing in Battalion column. Units echeloned their formations to the left to avoid landing directly into the sun and to effectively utilize all of the available landing area. Light small arms fire was received during the armed helicopter reconnaissance of the LZ. The second assault landing was completed at 0900 hours. The landing zone was adjusted 150 meters northeast of the original landing zone to facilitate troop movement into the objective area. Flight elements returned to Kuan Loc to refuel and reorganize. Due to a shortage of troops only fifteen aircraft were required to complete the third assault landing which terminated at 1035 hours. After the third lift fifteen additional troops, ill with malaria, were evacuated from Tanh Linh to Ham Tan. At 1215 hours, all battalion elements were released and returned to normal assigned III Corps missions.

c. The 74th Aviation Company (ASL) provided one O-1F for weather advisories, radio relay, and aerial surveillance.

d. The 197th Aviation Company (Armed) provided armed helicopters for flight route and surrounding area reconnaissance, landing zone marking, prestrike, and continuous overhead cover for the ground operations.

SEQUENCE OF EVENTS

070600 Jan 66	145th Avn Bn Fwd CP opened Bien Hoa
0615	145th Avn Bn closed SNAKEPIT
0630	Final briefing
0700	C&C helicopter reported Kuan Loc
0700	Pathfinder reported LZ ORANGE
0713	145th Avn Bn departed Bien Hoa
0725-0755	Tac Air prestrike, LZ RED
0730	145th Avn Bn arrived LZ ORANGE loaded and departed
0755-0800	Armed helicopter, marked and prestruck LZ RED
0800	1st Aslt landing LZ RED
0830	145th Avn Bn arrived LZ ORANGE loaded and departed
0900	2nd Aslt landing LZ RED
0930	145th Avn Bn arrived Kuan Loc and refueled

0943-1030	Completed 3rd Aslt landing, LZ RED
1025	3rd Flight Element arrived Tan Linh loaded and departed
1035	3rd Flight Element landed LZ RED
1200	145th Avn Bn released
1200-1730	145th Avn Bn prepared for following days operation which was to require a maximum effort.

e. Supporting this operation the 145th Aviation Battalion provided one fixed wing and 56 rotary wing aircraft flying 219.4 hours and 448 combat sorties.

4. ADMINISTRATION AND LOGISTICS:

a. Supply:

Coordination was effected with the G-4 advisor of the 10th ARVN Division at Xuan Loc on 6 January 1966 for the use of an area to conduct rapid refueling for the operation on 7 January 1966. Arrangements were made for two CH-47's to move fifteen 500 gallon bladders of JP-4 to Xuan Loc. In addition, five men and eleven pumping units were transported to Xuan Loc on 6 January 1966 in order to prepare the area for rapid refueling.

b. Maintenance:

The following aircraft of the 118th Aviation Company required maintenance support as indicated:

(1) UH-1D, SN 64-13702, experienced a fuel control unit failure and did not make the lift.

(2) UH-1B, SN 62-4590, was inspected by the crew chief after the first lift and the mixing lever bearings were found to be excessively worn. The mixing levers were replaced and the aircraft returned to home station.

c. Medical:

The 430th Medical Detachment provided an air airmobile aid station at Xuan Loc with the Battalion Flight Surgeon supervising. No casualties were reported.

5. COMMENTS:

a. The Command and Control helicopter overflying the operation observed three Viet Cong fleeing the operational area. The Command and Control helicopter descended into the operational area to mark and suppress their escape route with machine gun fire. One Viet Cong was killed, and the others took refuge under heavy cover. The command and control helicopter again marked the hiding place of the Viet Cong and directed armed helicopters to strike the area to insure that their escape route was blocked.

b. During the dry season in areas that are dusty, protective goggles must be provided to all ground personnel, particularly those conducting helicopter refueling operations, and pathfinder duties.

CHARLES E. ONOR JR.
Lt. Colonel Infantry
Commanding

HEADQUARTERS
145TH AVIATION BATTALION
APO San Francisco 96307

AVAW-FC

1 February 1966

SUBJECT: After Action Report, 145th Aviation Battalion Operation 5-66
14 January 1966

TO: Commanding General, 1st (US) Infantry Division, APO San Francisco
96345
Commanding Officer, 12th Aviation Group, APO San Francisco 96307
Senior Advisor, III ARVN Corps, APO San Francisco 96297

1. TASK ORGANIZATION:

a. Battalion Headquarters:

145th Aviation Battalion Command and Control Helicopter
74th Aviation Company (-)
197th Aviation Company (-)

b. 1st Flight Element: A Company, 501st Aviation Battalion:

10 UH-1D Helicopters
4 UH-1B (Armed) Helicopters
1 UH-1B (Maint) Helicopter

c. 2nd Flight Element: A Company, 82nd Aviation Battalion:

10 UH-1D Helicopters
1 UH-1B (Maint) Helicopter

d. 3rd Flight Element: 68th Aviation Company:

10 UH-1D Helicopters
4 UH-1B (Armed) Helicopters
1 UH-1B (Maint) Helicopter

e. Support Element:

145th Aviation Battalion Communications Section
145th Aviation Battalion Maintenance Section
145th Aviation Battalion Pathfinder Detachment
145th Aviation Battalion POL Section
56th Transportation Company (-)
57th Medical Detachment (Air Ambulance)(-)

MISSION: The 145th Aviation Battalion provided troop carrier, armed escort, and Command and Control helicopters to extract 3 battalions (1/503, 1/RAR, and 2/503) of the 173rd Airborne Brigade from LZ FEBRUARY (coordinates XT 633308) and LZ JULY (coordinates XT 651268). 10 kilometers northeast of Trung Lap, to Bien Hoa, RVN.

3. SUMMARY OF OPERATION:

a. This operation was planned and coordinated with the Aviation Officer and C-3 of the 173rd (US) Airborne Brigade. An initial briefing was conducted by the Commander and Staff, 145th Aviation Battalion, 131600 January 1966. On the following day, 140650 January 1966, Commanders and the Staff again assembled for final briefing and last minute instructions, while Aviation elements were being organized and prepared for the extraction. The 145th Aviation Battalion staged under the hours of darkness in the SNAKEBIT (Bien Hoa), and the 147th Aviation Company (Med Hcptr) was staged after first light in the BIRDCAVE (Bien Hoa).

b. Seven extractions were planned; three from LZ FEBRUARY, and four from LZ JULY, with the 145th Aviation Battalion, consisting of 30 UH-1D assault troop carriers, making the initial and final extractions, while the CH-47 (CHINOOK) flight from the 147th Aviation Company made intermediate extractions from the secured LZ's. Flight elements departed the staging area at 0740 hours enroute to LZ FEBRUARY for extraction of the 1/503rd Airborne Infantry Battalion. The Battalion was short 3 UH-1D's, of the required 39 helicopters, due to maintenance and other commitments. The first flight element received enemy automatic weapons fire along final approach into the LZ and all subsequent elements were directed to fly east of the planned flight route in order to minimize exposure. Radio communications with the CH-47's for all practical purposes was impossible on both UHF and FM frequencies. Consequently, the CH-47 flight leader was unable to receive rerouting instructions and overflew the enemy automatic weapon positions and received numerous small caliber hits. Seven CH-47's out of nine committed for the operation made their initial extraction; however, due to enemy ground fire and other maintenance difficulties, only four were able to make their second extraction and their availability subsequently fell to two. One medium helicopter was repaired in the staging area and returned the operational area. Due to the heavy loss in medium helicopters, which represented a large portion of the troops to be extracted, an emergency call was made to the Battalion Forward CP to scramble every available helicopter that could be obtained, since the integrity and strength of final security forces in LZ had been diluted. Enemy fire in and around the LZ had increased markedly and although the Battalion had increased troop carrier helicopters to maximum emergency over loads (9 and 10 troops per aircraft), twelve troops were still left in the LZ. The command and control helicopter directed close armed helicopter cover and went into the LZ to extract four of the remaining troops. The Pathfinder helicopter and one armed helicopter were also directed into the LZ to effect final personnel extraction while additional armed helicopters were suppressing enemy positions within 50 meters of the LZ with machine guns, rockets, and 40MM grenades. One aviator was wounded in the arm during this extraction and one enemy 50 caliber machine gun was reported at coordinates XT 625302.

c. All helicopters were refueled, rearmed and inspected prior to the next phase of the extraction of the 1/MAI and 2/503rd Airborne Infantry battalion from LZ JULY. This LZ had received enemy mortar fire prior to the arrival of helicopters and light to moderate fire was received during the extraction upon departure from the area. Subsequent extractions went smoothly; however, the reduction in lift capability, with the CH-47 losses, continued to disrupt the planned extraction and jeopardized the integrity and strength of the final security force. In view of the reduced lift capability and the hazard presented to the small remaining security force; it was decided to extract all ground elements to a nearby, secure intermediate position and when all troops were out of the threatened area, to continue their repositioning to Bien Hoa unhampered or jeopardized by refueling interruptions.

d. The 197th Aviation Company (-) provided seven UH-1B (Armed) helicopters for flight route reconnaissance, LZ reconnaissance, marking, escort, and surrounding area cover. The 197th also extracted two troops from the first LZ.

e. One C-119 airplane from the 74th Aviation Company provided weather advisory information, radio relay, surveillance of the area and flight element navigational assistance.

f. The Battalion Command and Control helicopter carried the air-mobile force commander's representative, artillery controller, air liaison officer, and the air mission Commander. Necessary coordination, alternate planning and controlling was easily effected by the assembled Command and Control group. The intermediate LZ at Trung Lap was also marked by the Battalion Command and Control helicopter.

g. During the extraction the Battalion committed 65 helicopters, one fixed wing airplane, and flew 247.4 hours and 213 sorties. A total of 2060 troops were extracted; 525 by CH-47 and 1535 by UH-1D troop carriers.

4. ADMINISTRATION AND LOGISTICS:

a. Supply:

(1) The Battalion FCL representatives closed Bien Hoa, at 0635 hours. A total of eight JP/4 tankers were available from Battalion resources at Bien Hoa.

(2) Arrangements were made to augment these tankers with one tanker from the 120th and 197th Aviation Companies and one 2 1/2 ton truck with 500 gallon bladders with pumping unit from HHD, 145th Aviation Battalion.

(3) With the attachment of eight CH-47's from the 147th Aviation Company, arrangements were made for two 5,000 gallon tankers from the 506th M Company from the Long Binh area for support in refueling.

(4) A total of sixty-four aircraft were refueled for a total consumption of 16,525 gallons of JP/4.

b. Maintenance:

(1) The following aircraft of Co A 501st Aviation Battalion received damage as indicated:

(a) UH-1D, SN 64-13922, received bullet damage through pilot's door, lower forward cabin window, and overhead cabin window. Aircraft continued mission and returned to home station for repairs.

(b) UH-1D, 64-13669, received combat damage to main rotor blade while departing the Landing Zone. Aircraft continued mission and returned to home station for repairs.

(c) UH-1B, SN 63-8650, 6th Airlift Platoon, experienced a hot start during starting, prior to lift. Aircraft did not make the lift and was towed to the 151st Transportation Detachment Detachment for inspection.

(2) The following aircraft of the 68th Aviation Company received damage as indicated:

(a) UH-1D, SN 64-14809, received bullet damage to main rotor blade. Aircraft continued mission and returned to Snakepit. Aircraft was grounded for repairs upon its return to home station.

(b) UH-1D, SN 64-14799, left fuel boost pump was noticed to be leaking after landing at the Snakepit for refueling. Temporary repairs were made and aircraft was flown to home station for installation of a new boost pump.

(3) The 147th Aviation Company had seven CH-47's that received bullet damage entering and departing the Landing Zone. Six aircraft returned to the Birdcage where temporary repairs were made on three of the damaged aircraft. Three aircraft remained in the Birdcage for further repairs. The seventh aircraft was unable to return to the Birdcage but made a safe landing at Phu Loi for repairs.

c. Medical:

(1) The 93rd Medical Detachment ambulance was on standby at the Snakepit.

(2) The Battalion Surgeon was located at the forward command post.

(3) One casualty: WO Wolf sustained multiple abrasive wounds of right forearm and right side of face.

Puncture wounds were also sustained in right upper forearm from metallic fragments. The Battalion Surgeon removed the fragments, cleaned, and dressed the wound. Wounds were sustained entering LZ FEBRUARY. No disability resulted.

5. PROBLEM AREAS:

a. Communication on UHF and FM with the CH-47 helicopters was a major problem. The helicopter seems to have so many operating systems that communications are garbled, blocked and distorted, making control extremely difficult.

b. An adequate number of aircraft were not made available to the Battalion by the 1st Infantry Division Army Aviation Control Center for the extraction. The Battalion was required to furnish an additional five helicopters to III ARVN Corps for administrative missions. This prevented the Battalion from providing the additional helicopters needed for the extraction.

c. Coordination with USAF operations at Bien Hoa for use of the PSP inactive runway for CH-47 staging received a negative response. This runway is not currently being used and is ideally suited for large helicopter staging operations at Bien Hoa. Denying the use of a valuable piece of real estate for support of combat operations when the area under question is not being utilized at all is considered poor cooperation for the attainment of a common goal.

SEQUENCE OF EVENTS

140645 Jan 66	145th Avn Bn closed Snakepit
0650	Final Briefing
0715	Pathfinder reported to LZ FEBRUARY
0740	145th Avn Bn departed Bien Hoa
0755	147th Avn Co (-) departed Bien Hoa
0800	1st Extraction LZ FEBRUARY (145th)
0815	2nd Extraction LZ FEBRUARY (147th)
0822	145th arrived and departed Bien Hoa
0837	147th arrived Bien Hoa
0835-0920	147th refueled Bien Hoa
0845	3rd Extraction LZ FEBRUARY (145th)
0915-0915	145th arrived Bien Hoa and refueled
0920	147th departed Bien Hoa
0940	4th Extraction LZ JULY (147th)
0945	145th Avn Bn departed Bien Hoa
1005	147th Avn Co arrived and departed Bien Hoa
1010	5th Extraction LZ JULY (145th)
1025	6th Extraction LZ JULY (147th)
1050	147th Avn Co released
1100	7th Extraction LZ JULY (145th)
1120	Mission complete; Bn elements released

6. COMMENTS AND RECOMMENDATIONS:

Although the CH-47 has a large troop lift capability and was employed in an area considered secure, it is not considered suitable for extraction missions. The helicopter is extremely large and relatively unmaneuverable, necessarily slow on final approach. Extractions almost invariably become as hazardous as combat assaults and are more ideally supported by the smaller, more elusive UH-1D assault troop carrier. It is recommended that the larger CH-47 be utilized for equipment and bulk supply missions and for necessary repositioning of troops from one secure area to another.

Charles M. Honour Jr.
CHARLES M. HONOUR JR.
Lt. Colonel Infantry
Commanding

HEADQUARTERS
145TH AVIATION BATTALION
APO San Francisco 96307

AVAW-FC

31 January 1966

SUBJECT: After Action Report, 145th Aviation Battalion Operation 6-66,
24 January 1966

TO: Commanding General, 1st Infantry Division, APO San Francisco 96345
Commanding Officer, 12th Aviation Group, APO San Francisco 96307
Senior Advisor, III Corps, APO San Francisco 96327

1. TASK ORGANIZATION:

a. Battalion Headquarters:

145th Aviation Battalion Command and Control Helicopter
197th Aviation Company (Armed) (-)

b. 1st Flight Element: 118th Aviation Company (A1):

11 UH-1D Helicopters (1 Replacement)
5 UH-1B (Armed) Helicopters
1 UH-1B (Maint) Helicopter

c. 2nd Flight Element: A Company, 82nd Aviation Battalion (A1):

11 UH-1D Helicopters (1 Replacement)
5 UH-1B (Armed) Helicopters
1 UH-1B (Maint) Helicopter

d. 3rd Flight Element: A Company 501st Aviation Battalion (A1):

11 UH-1D Helicopters (1 Replacement)
5 UH-1B (Armed) Helicopters
1 UH-1B (Maint) Helicopter

e. Support Element:

145th Aviation Battalion Communications Section
145th Aviation Battalion Maintenance Section
145th Aviation Battalion Pathfinder Detachment
145th Aviation Battalion POL Section
56th Transportation Company (-)
57th Medical Detachment (Air Ambulance) (-)

2. MISSION: The 145th Aviation Battalion (-) provided troop carriers, armed cover and Command and Control aircraft for 173rd (US) Airborne Brigade (-) air movement into Landing Zone FALCON, (coordinates XT 943238), 2 Km northwest of Tan Uyen.

3. SUMMARY OF OPERATION:

a. The 145th Aviation Battalion Commanders and Staff, troop carriers and armed aircraft assembled at the Bien Hoa forward Command Post (Snakepit) at 240950 January 1966 for final briefing and organization for combat.

b. The 145th Aviation Battalion (-) departed the Bien Hoa staging area (Snakepit) at 241051 January 1966 enroute to LZ FALCON. The landing zone was secured by an infantry company from the 48th ARVN Regiment. Since the LZ had been secured by friendly elements, no artillery or tactical air preparation was required; however, 4 A-1E's were on Air Gap, and two batteries of artillery were available for support if required.

c. Prior to the troop carriers arrival, the Command and Control helicopter executed a last minute reconnaissance of the landing zone. During this low reconnaissance of the LZ, numerous bushes and scrub growth were spotted that denied areas of the landing zone to the flight elements because of the tail rotor obstacles. Continuing the reconnaissance, an area south and adjacent to the primary LZ was selected to be used in conjunction with the original landing zone. Flight elements were alerted to the change in LZ's. Flight elements changed formation enroute to adjust for the change in LZ configuration. The first lift was in the LZ as planned at 1100 hours, and the second and final lift was completed at 1119 hours.

d. All Battalion elements were released at 1126 hours. Supporting this operation, the 145th Aviation Battalion provided 60 helicopters flying 60.3 hours and 240 combat sorties.

SEQUENCE OF EVENTS

240950 Jan 66	145th Avn Bn Closed SNAKEPIT
1000	Final Briefing
1051	145th Avn Bn Departed SNAKEPIT
1100	1st Landing LZ FALCON
1107-1100	145th Avn Bn Loaded troops and departed SNAKEPIT
1117	2nd Landing, LZ FALCON
1126	Bn elements released

4. ADMINISTRATION AND LOGISTICS:

a. Supply

Refueling was not required for this operations; however, fuel were available and standing by at the Snakepit.

b. Maintenance:

There were no maintenance problems encountered as a result of action or mechanical malfunction during this operation.

c. Medical:

(1) The 93rd Medical Detachment's Commanding Officer (Flight Surgeon), ambulance, and attendants were at the Battalion Forward Command Post during the operation.

(2) No casualties were reported.

5. COMMENTS: All aircraft reported to the staging area with 2000 lbs of fuel to facilitate maximum loading of US combat troops and to increase ease and safety of aircraft handling. The operation was conducted in a smooth, professional manner.

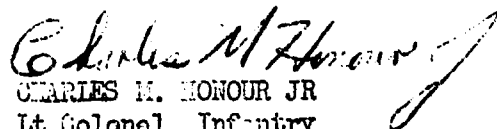
CHARLES M. HONOUR JR
Lt Colonel, Infantry
Commanding

HEADQUARTERS
145TH AVIATION BATTALION
APO San Francisco 96307

AVAW-FC

17 February 1966

SUBJECT: After Action Report, 145th Aviation Battalion Operations 8 and
9-66, 4 & 9 February 1966.

TO: Commanding General, 1st Infantry Division, APO San Francisco 96345
Deputy Senior Advisor, III ARVN Corps, APO San Francisco 96227
Commanding Officer, 12th Aviation Group, APO San Francisco 96307

1. TASK ORGANIZATION:

a. Battalion Headquarters:

145th Aviation Battalion Command and Control Helicopter
60th Aviation Company (-)
197th Aviation Company (-)

b. 1st Flight Element: A Company, 82nd Aviation Battalion:

13 UH-1D Helicopters
5 UH-1B (Armed) Helicopters
1 UH-1B (Paint) Helicopter

c. 2nd Flight Element: A Company, 501st Aviation Battalion:

12 UH-1D Helicopters
5 UH-1B (Armed) Helicopters
1 UH-1B (Paint) Helicopter

d. Support Element:

145th Aviation Battalion Communication Section
145th Aviation Battalion Maintenance Section
145th Aviation Battalion Pathfinder Detachment
56th Transportation Company (-)
57th Medical Detachment (Air Ambulance) (-)

2. MISSION: The 145th Aviation Battalion (-) provided troop carriers, armed cover, surveillance and control aircraft for 173rd Airborne Brigade (1/RAR) airmobile assault into TAOR, 10 Km northeast of Tan Uyen; thereafter provided troop carriers, armed cover, and control aircraft for extraction on order.

3. SUMMARY OF OPERATION:

a. The 145th Aviation Battalion forward Command Post, combat, and combat support elements displaced to the Dien Hoa (Snakepit) helicopter staging area, beginning 040800 February 1966. Final coordination, briefing and preparation for the 1/RAR heliborne movement was completed. Elements were reassembled for the 1/RAR extraction beginning 090900 February 1966.

b. The first flight element of the heliborne lift departed the Snakepit at 1021 hours followed by the remaining lift and support elements. The battalion was short one UH-1D troop carrier due to a last minute maintenance problem. Arrival and landing in the operational area presented no problems; however, the ground force securing the LZ could not be contacted on the assigned frequency for direct coordination of the LZ smoke marks. The security force had also selected and subsequently marked and unsuitable area. The unsuitable area was a burned off field, heavily cluttered with tail rotor obstacles and soot. Flight elements were notified and the LZ was adjusted, from the Command and Control helicopter, 50 meters to the east into an obstacle free rice paddy area. The first landing was effected without incident. During the 2nd and 3rd lifts, the flight formation was changed from staggered trail to V's of 3 in trail in order to facilitate landing in the best available LZ space. Light small arms fire was received during the approach on the last lift. One aircraft received two hits during the lift. The mission was completed at 1150 hours and all flight elements were released to perform III Corps support missions.

c. Extraction of the 1/RAR was effected beginning 090900 February 1966. A total of three lifts from LZ 106 (coordinates XT 970363), 9 km southeast of Phuoc Hoa were required. The 145th Aviation Battalion pathfinder organized ground elements in the LZ for extraction and all operations were controlled from the command and control helicopter. Moderate enemy small arms and automatic weapons fire was received during approach and departure from the LZ. Subsequent Tac Air and armed helicopter strikes were directed into areas of reported enemy fire and flight routes were altered to avoid these areas. No casualties or aircraft hits were incurred by air lift elements during the operation.

d. The 197th Aviation Company performed flight route and surrounding area reconnaissance and provided landing zone marking and prestrike for the combat assault and armed overhead cover during the extraction.

e. In support of the two operations the 145th Aviation Battalion committed 37 rotary wing aircraft and flew 1036 hours and 444 sorties.

f. The command and control helicopter coordinated flight route clearance and controlled each phase of the air movement. During the extraction medical evacuation aircraft were directed to evacuate casualties from a mined utility prime mover. In addition Tac Air and armed helicopters were directed in strikes against known and suspected Viet Cong positions.

4. ADMINISTRATION AND LOGISTICS:

a. Supply:

(1) Battalion S-4 representative closed Dien Hoa 0850 hours 4 February 1966 and 0800 hours 9 February 1966.

(2) No major refueling of aircraft was conducted during operation on 4 February 1966. Refueling of 22 aircraft was conducted on 9 Feb for a total consumption of 2500 gallons of JP/4.

b. Maintenance:

(1) The following aircraft of Co A/501st Aviation Battalion experienced maintenance problems as indicated (4 Feb 66):

(a) UH-1D, SN 63-13683, blew the engine oil filter "O" ring during starting for first lift. "O" ring was replaced and aircraft participated in the second and third lifts.

(2) The following aircraft of the 197th Aviation Company received combat damage as indicated (4 Feb 66):

(a) UH-1B, SN 63-12945, received small arms round through the tail boom and main rotor blade. Aircraft returned to home station for repairs.

(3) No maintenance problems or combat damage was encountered or received on 9 February 1966.

c. Medical:

(1) Commanding Officer, 93rd Medical Detachment was located at the Battalion forward command post on 4 February 1966. Battalion Surgeon was at the battalion forward command post on 9 February 1966.

(2) 93rd Medical Detachment provided two medical aid men and ambulance on standby at Snakepit throughout both operations.

(3) No casualties were reported or treated on either operation.

5. PROBLEM AREAS:

a. The landing zone selected by the ground security force for the initial operation was unsuitable for helicopter operations. This is a continuing problem. Ground units are not cognizant of obstacle restrictions and space requirements; not to mention approach angles and departure requirements. This particular LZ was also a burned out area, which is quite common during the dry season, and was full of soot and burned debris.

This is extremely dangerous and highly conducive to accidents due to the many fine particules getting into the eyes and blinding crew members during approach and departure. Also the ground security element could not be reached on the assigned radio frequency and had to be given relayed instructions. Relayed information will normally suffice; however, in airmobile operations, direct responsive, and positive contact is required due to minute timing and reduction of time and space factors.

b. The command and control group was separated during the initial operation, which is not desirable or recommended. Coordination had been effected with the Airmobile Force Commander by the helicopter support unit representative, in order to control the operation from the Airmobile Battalion command and control helicopter. Instead of adhering to this plan the Airmobile Force Commander departed the staging area utilizing a second command and control helicopter and coordination of LZ adjustment, artillery, and air support at this point became practically non-existent.

6. RECOMMENDATIONS:

a. That ground units be instructed on the requirements for selection of a helicopter landing zone.

b. That the command and control group controlling an airmobile operation direct the operation from the same command and control helicopter. This group should as a minimum, include; the Airmobile Force Commander, the Air Liaison Officer, and artillery representative from the FSCG, and the Air Mission Commander.

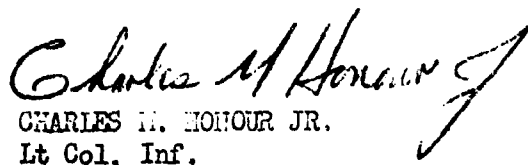
CHARLES H. HONOUR JR.
Lt Col, Inf.
Commanding

HEADQUARTERS
145TH AVIATION BATTALION
APO San Francisco 96307

AVAW-FC

15 February 1966

SUBJECT: After Action Report, 145th Aviation Battalion Frag Order 10-66,
12 February 1966

TO: Commanding General, 1st Infantry Division, APO San Francisco 96345
Commanding Officer, 12th Aviation Group, APO San Francisco 96307
Deputy Senior Advisor, III ARVN Corps, APO San Francisco 96227

1. TASK ORGANIZATION:

a. Battalion Headquarters:

145th Aviation Battalion Command & Control Helicopter
74th Aviation Company (-)
197th Aviation Company (-)

b. 1st Flight Element: 68th Aviation Company (A.L.):

12 UH-1D Helicopters (2 replacements)
4 UH-1B (Armed) Helicopters
1 UH-1B (Maint) Helicopter

c. 2nd Flight Element: A, Co 501st Aviation Battalion (A.L.):

10 UH-1D Helicopters
4 UH-1B (Armed) Helicopters
1 UH-1B (Maint) Helicopter

d. 3rd Flight Element: 118th Aviation Company (A.L.):

10 UH-1D Helicopters
1 UH-1B (Maint) Helicopter

e. Support Element:

145th Aviation Battalion Communications Section
145th Aviation Battalion Maintenance Section
145th Aviation Battalion Pathfinder Detachment
145th Aviation Battalion POL Section
56th Transportation Company (-)
57th Medical Detachment (Air Ambulance) (-)

2. MISSION: The 145th Aviation Battalion provided troop carrier, armed helicopters, surveillance and control aircraft for Special Forces airmobile assault into three landing zones (LZ RED, coordinates YT 143303, LZ BLUE, coordinates YT 153281, LZ GREEN, coordinates YT 147287) 20 km northeast of Bion Hoa; thereafter, prepared to lift reserve forces on order.

3. SUMMARY OF OPERATION:

a. Battalion combat and supporting elements closed at the Bion Hoa (Snakepit) staging area 120600 February 1966 (during the hours of darkness) for final briefing and organization for combat.

b. Artillery and tactical air strikes on and around the LZ's occurred on schedule and were highly effective. The first and second assault into LZ RED was unopposed; however, light enemy small arms fire was received along the flight approach and departure route. Dust and flying burned debris was extremely bad in the LZ due to the area being heavily burned. Upon completion of the second assault, Battalion flight elements were separated as planned and sent to separate landing zones (Phuoc Vinh and Bion Hoa) for movement of assault forces into LZ BLUE. Tactical air preparation of LZ BLUE was timely and again extremely effective. Battalion flight elements were converged over assigned aircraft control points and directed in the third assault landing into LZ BLUE as scheduled. Heavy automatic weapons and small arms fire was received along the approach and departure route from the LZ. Flight routes were adjusted to avoid known areas of enemy fire and armed helicopter strikes were directed in the area. The fourth assault into LZ GREEN and troop reinforcing movements into LZ RED were effected without any difficulty.

c. The 197th Aviation Company (A med) provided armed fire teams for flight route reconnaissance, LZ marking and prestrike. In addition, fire teams were provided for escort of troop carriers and overhead cover for the ground operation.

d. Command and Control of the operation was effected from the Battalion Command and Control helicopter. In support of the operation, 56 helicopters and one O-1F of the 145th Aviation Battalion flew 204.2 hours and 357 sorties.

4. ADMINISTRATION AND LOGISTICS:

a. Supply:

(1) Arrangements were made to augment the eight tankers available at Bion Hoa for the refueling operations from the following units.

Son Hut. (a) Two tankers from the 120th Aviation Company from Tan

Son Hut. (b) One tanker from the 197th Aviation Company from Tan

(c) Two tankers from A/82nd Aviation Battalion from Bien Hoa.

(d) One 2½ ton truck with two 500 gallon bladders from HHD, 145th Aviation Battalion.

(2) All UH-1D's were fueled or defueled to 1200 lbs prior to start of the operation.

(a) All UH-1D's were fueled to capacity.

(3) A total of fourteen tankers were used to refuel 56 helicopters in twenty (20) minutes time. A total of 4430 gallons of JP/4 was dispensed in support of the operation.

b. Maintenance:

(1) The following aircraft from A/501st Aviation Battalion encountered maintenance problems and combat damage as indicated.

(a) UH-1D, SN 64-13796, failed to start prior to first lift. Battery was replaced and aircraft started and participated in the initial lift.

(b) UH-1B, SN 63-12997, received small arms round through right cabin nose window. Aircraft was inspected and continued the mission to completion.

(2) UH-1D, SN 64-13571, A/82nd Aviation Battalion experienced low power with high torque reading and exhaust gas temperature of 640 degrees. Aircraft was inspected and found the HL blades were nicked and bent. Aircraft did not make the last lift, but was able to return to home station for repairs.

(3) UH-1B, SN 64-13999, 197th Aviation Company received small arms round through leading edge of tail rotor blades. Damage occurred on last lift and aircraft returned to home station for repairs.

c. Medical:

(1) Commanding Officer (flight surgeon), 93rd Medical Detachment was located at Battalion forward command post throughout the operation.

(2) 93rd Medical Detachment provided ambulance and two aid men on standby at Snakepit staging area during operation.

(3) Battalion flight surgeon was airborne and on station throughout the operation.

(4) No casualties were reported or treated during these operations.

5. PROBLEMS: FM radio interference continues to be a major problem. During this operation and unidentified US Artillery fire direction net was operating on the 145th Aviation Battalion alternate FM frequency. This frequency is used by the battalion for critical pathfinder operations and control.

6. COMMENTS AND RECOMMENDATIONS:

a. This operation, although large and complex, was performed in a highly professional and extremely smooth manner.

b. Recommend the 1st Infantry Division Signal Officer closely monitor FM frequency assignments in order to preclude duplicate assignment of FM radio frequencies with aviation units.

Charles M Honour Jr
CHARLES M. HONOUR JR.
Lt Col, Inf.
Commanding

HEADQUARTERS
145TH AVIATION BATTALION
AFC San Francisco 96227

AVAW-FC

24 February 1966

SUBJECT: After Action Report, 145th Aviation Battalion Operation 11-66,
21 February 1966

TO: Commanding General, 1st Infantry Division, AFC San Francisco 96345

1. TASK ORGANIZATION:

a. Battalion Headquarters:

145th Aviation Battalion Command and Control Helicopter
74th Aviation Company (-)
197th Aviation Company (-)

b. 1st Flight Element: 68th Aviation Company (AML):

14 UH-1D Helicopters
5 UH-1B (Armed) Helicopters
1 UH-1B (Maint) Helicopter

c. 2nd Flight Element: 118th Aviation Company (AML):

13 UH-1D Helicopters
5 UH-1B (Armed) Helicopters
1 UH-1B (Maint) Helicopter

d. 3rd Flight Element: A Co, 501st Aviation Battalion (AML):

13 UH-1D Helicopters
5 UH-1B (Armed) Helicopters
1 UH-1B (Maint) Helicopter

e. Support Element:

145th Aviation Battalion Communications Section
145th Aviation Battalion Pathfinder Detachment
145th Aviation Battalion Maintenance Section
56th Transportation Company (-)
57th Medical Detachment (-)

116

2. MISSION: The 145th Aviation Battalion provided troop carriers, armed helicopters, and command and control aircraft to support the 2nd Brigade, 1st (US) Infantry Division, airmobile assault into landing zones ANN (coordinates XT 448375) and BETTY (coordinates XT 487385); thereafter, provided armed helicopters for continuous overhead cover of ground operations and troop carrier helicopters as required for logistical support throughout the operation, and for extraction of ground forces on order.

3. SUMMARY OF OPERATION:

a. A detailed command and staff briefing was conducted on 20 February 1966 for all Battalion and supporting elements in preparation for 1st Infantry Division Operation MASTIFF. In addition, a final briefing was conducted for all flight crews and support personnel in the Bien Hoa (SNAKEPIT) staging area on the morning of the operation. Battalion flight elements closed into the SNAKEPIT under the cover of darkness for organization and preparation for combat.

b. The first lift departed the staging area at 0816 hours enroute to Dau Tieng (coordinates XT 495470) for troop loading and the initial assault into LZ ANN. Organic armed platoons of the airmobile companies preceded the flight elements into the forward pickup site for early replenishment of fuel. Tactical air, artillery, and the armed helicopter preparation of LZ ANN was very effective and the assault landing was unopposed. Light small arms fire was received 300 meters southeast of the LZ by armed helicopters covering the assault landing. Suppressive fires were rendered with unknown results. Three additional lifts were made into LZ ANN with no resistance being encountered. Light enemy small arms and automatic weapons fire was received enroute to the LZ on subsequent lifts by the lead flight element; other flight elements were diverted in order to avoid the known enemy positions.

c. Prior to the completion of all lifts into LZ ANN; tactical air and artillery preparations were begun on LZ BETTY, 4 Km to the east. Armed helicopters completed the preparation of LZ BETTY, marked the LZ, and escorted the troop carriers during the assault landings. Two relatively unopposed lifts were made into LZ BETTY. Light small arms fire was received in the vicinity of the LZ with 3 aircraft receiving 4 hits. Upon completion of the last lift, at 1030 hours, all flight elements returned to Dau Tieng for minimum refueling and return to home station. Two troop carriers, one command and control helicopter and two light fire teams were placed in direct support of the ground operation upon completion of the airmobile assault.

d. The 197th Aviation Company provided armed helicopters for escort, flight route and LZ reconnaissance, LZ marking and prestrike. In addition, armed fire teams provided continuous coverage during the operation. One armed platoon was used for armed reconnaissance along the Saigon River, in sector, sealing Viet Cong routes from the operational area.

e. The 74th Aviation Company provided one O-1F aircraft for radio relay, surveillance, and weather advisories throughout the operation.

SEQUENCE OF EVENTS

0700	21 Feb 66	Final Briefing
0715		145th Avn Bn closed Bien Hoa
0745		145th Avn Bn C&C reported Dau Tieng
0748		Armed Flt's arrived Dau Tieng
0816		145th Avn Bn departed Bien Hoa
0820-0835		Arty prep, LZ ANN
0835-0855		Tac Air prep, LZ ANN
0848		145th Avn Bn arrived Dau Tieng loaded and departed
0855-0900		Armed Hopter prep, LZ ANN
0900		1st Aslt landing, LZ ANN
0915		2nd Aslt landing, LZ ANN(A)
0925, 0945		Tac Air prep, LZ BETTY
0930		3rd Aslt landing, LZ ANN(B)
0945		4th Aslt landing, LZ ANN(B)
0945-0955		Arty prep, LZ BETTY
0955-1000		Armed Hopter prep, LZ BETTY
1000		5th Aslt landing, LZ BETTY
1015		6th Aslt landing, LZ BETTY
1020		Armed Hopters returned Dau Tieng and refueled
1045		145th Avn Bn returned to home station and were released to assigned missions

f. In support of the air movement and ensuing ground operation, the 145th Aviation Battalion committed one O-1F airplane and 75 helicopters, flying 205.2 hours and 975 sorties. A total of 1273 troops were lifted in 1 hour and 27 minutes. The Battalion Command and Control helicopter was used by the Brigade Command Group for coordination and control of Tac Air, artillery, and other supporting elements during the air movement of the brigade.

g. The 145th Aviation Battalion was notified by 1st Infantry Division Army Aviation Control Center, 241930 February 1966, to prepare for airmobile extraction of 2nd Brigade, 1st Infantry Division on the following morning. Battalion combat and supporting elements were issued a warning order for the operation and alerted for early morning assembly in the Bien Hoa (SNAKEBIT) staging area. The Battalion S-2 and S-3 departed prior to daylight for the Brigade forward command post at Dau Tieng for coordination, final briefing, and reconnaissance of the intended extraction sites. Two sites were selected for the extraction; LZ RED (coordinates XT 532350) and LZ BLUE (coordinates XT 523359). A final briefing was given to all participating personnel at the SNAKEBIT and battalion elements departed at 0920 hours for the first extraction from LZ RED. The Battalion Pathfinder Detachment assisted with the organization and loading in LZ RED; all group personnel were extracted in two lifts without any major difficulty. Light enemy small arms fire and automatic weapons fire was received during the approach and departure from the LZ.

Four lifts were required for extraction of two Battalions from LZ BLUE. Some delay was experienced due to ground unit disorientation and late arrival in the LZ for pickup. All troops were extracted to the Dau Tieng airfield. Armed helicopters and troop carriers were refueled and returned to home station at 1130 hours.

h. The Battalion Command and Control helicopter was used by the Brigade Command Group for coordination and control of the operation. A total of 1025 troops were extracted by 30 helicopters flying 99.3 hours and 585 combat sorties in support of the operation. Three aircraft received a total of five hits and there were no casualties.

4. ADMINISTRATION AND LOGISTICS:

a. Supply:

(1) All Class III and V were supplies by 1st Infantry Division in support of this operation.

(2) Coordination was made by the Asst S-4, 145th Aviation Battalion with Asst S-4, 1st Aviation Battalion and G-4, 1st Infantry Division to verify repositioning of supplies.

(3) Coordination was made with the Asst S-4, 2nd Bde, 1st Infantry Division to position Class V at three locations on the airfield for armed helicopters.

b. Maintenance:

(1) A maintenance representative was located at Dau Tieng throughout the operation.

(2) No maintenance problems were encountered during the operation.

c. Medical:

(1) The 93rd Medical Detachment provided two (2) medical aid men and ambulance on standby at the SHAKEPIT throughout the operation.

(2) The Battalion Surgeon was located at the 2nd Bde medical clearing station at Dau Tieng during the operation.

(3) No casualties were reported or treated during the operation.

5. COMMENTS AND RECOMMENDATIONS:

a. Communications could not be maintained with the air mission commander on the assigned VHF radio frequency due to interference and radio difficulty. The assigned frequency was the same as Saigon Tower (Tan Son Nhut) for ground control of aircraft and is heavily used for this purpose. Other available VHF frequencies are fully committed for control of armed helicopter platoons.

Lack of communications is also attributed to the air mission commander not being able to monitor the assigned control frequency due to other commitments. It is recommended that VHF radio frequencies not be used for overall control of airmobile operations and that a ground control reporting facility be established for reception of required progress reports.

b. There was an insufficient amount of JP/4 fuel at Dau Tieng to effectively sustain the operation throughout the day. Troop carriers were provided just enough fuel to enable them to return to home station. Had the tactical situation required emergency resupply, medical evacuation or repositioning of troops immediately after completion of airmobile assault operations, the missions could not have been accomplished because of the fuel problem. In addition, armed helicopters were not able to provide continuous overhead cover to support the ground troops throughout the day because of the shortage of fuel. The assistant S-4 of this Battalion coordinated with the Assistant S-4 of 2nd Bde prior to the start of the operations and advised that considerable more fuel would be necessary in support of the pending operation than what was planned for prestock at Dau Tieng. Recommend that in the future, units providing support for the 145th Aviation Battalion coordinate with the S-4 as far in advance as possible to establish fuel requirements of the Battalion.

c. Crews of the armed helicopters providing overhead cover to the ground troops subsequent to the airmobile operations were required to assemble 2.75 rockets prior to loading. This caused excessive delay on the ground. Recommend provisions to be made to assemble the 2.75 rockets prior to start of an operation to preclude loss of time by helicopter crews in providing effective overhead cover to ground troops.

d. Both operations were performed in an extremely smooth and professional manner.

Horst K Joost

HORST K. JOOST
Lt Col Inf
Commanding

HEADQUARTERS
145TH AVIATION BATTALION
APO San Francisco 96 307

AVAW-FC

24 February 1966

SUBJECT: After Action Report, 145th Aviation Battalion Operation 12-66
22 February 1966

TO: Commanding General, 1st Infantry Division, APO San Francisco 96345
Deputy Senior Advisor, III Corps, APO San Francisco 96227
Commanding Officer, 12th Aviation Group, APO San Francisco 96307

1. TASK ORGANIZATION:

a. Battalion Headquarters:

145th Aviation Battalion Command and Control Helicopter
197th Aviation Company (-)

b. 1st Flight Element: 118th Aviation Company (AML)

10 UH-1D Helicopters
5 UH-1B (Armed) Helicopters
1 UH-1B (Maint) Helicopter

c. 2nd Flight Element: A Co, 82nd Aviation Battalion (AML):

10 UH-1D Helicopters
5 UH-1B (Armed) Helicopters
1 UH-1B (Maint) Helicopter

d. 3rd Flight Element: 68th Aviation Company (AML):

12 UH-1D Helicopters (2 Replacement)
5 UH-1B (Armed) Helicopters
1 UH-1B (Maint) Helicopter

e. Support Element:

145th Aviation Battalion Communications Section
145th Aviation Battalion Pathfinder Detachment
145th Aviation Battalion Maintenance Section
145th Aviation Battalion POL Section
56th Transportation Company (-)
57th Medical Detachment (-)

121

2. MISSION: The 145th Aviation Battalion provided troop carriers, armed helicopters, surveillance aircraft and command and control aircraft to the 43rd ARVN Infantry Regiment airmobile assault into LZ WHITE (coordinates YS 419714) 8 Km southwest of Binh Gia.

3. SUMMARY OF OPERATION:

a. Battalion combat and supporting elements were closed into the Bien Hoa (SNAKEPIT) staging area for final organization, briefing and preparation for combat, 220550 February 1966. The SNAKEPIT was lighted and controlled by the Battalion Pathfinder Detachment for arrival of the aircraft prior to daylight.

b. The first flight element departed the SNAKEPIT at 0649 hours enroute to LZ ORANGE (An Loc, coordinates YT 44 109) for the initial loading of assault troops. Organic armed helicopter platoons of the airmobile companies preceded the lift elements to the forward staging area for refueling prior to the operation. This enabled the armed helicopters to remain on station as long as the troop carriers without additional refueling. Troops were loaded and all flight elements departed for the objective area preceded by an armed platoon of the 197th Aviation Company. Only organic armed helicopter support was used for the LZ preparation, since the area was extremely dry and subject to immediate burning; however, Tac Air was available on call. The first assault landing was made behind a one minute armed helicopter prestrike and was totally unopposed. The landing zone immediately caught fire as expected; however, all lift elements entered and departed the LZ without any difficulty. Light enemy small arms and automatic weapons fire was received along the departure flight route, approximately 6 Km northeast of the LZ. Flight elements were diverted around the known enemy locations and a Tac Air strike was coordinated and directed from the Command and Control helicopter on the enemy position.

c. The 2nd, 3rd and a partial 4th lift were diverted into an alternate LZ, 1 Km north of LZ WHITE, due to intense smoke and low visibility from the burning of the primary LZ. This had been anticipated during the planning phase of the operation and was coordinated in advance as part of the overall plan. The alternate LZ had been previously burned off and became extremely dusty from flying debris and burned particles. Flight formations were cautioned, spread out, and landed without incident. Light enemy fire was received north of the LZ by armed escort elements. The 1st lift was complete at 1021 hours and all flight elements were released for return to home station, except for 3 troop carriers and two light fire teams which remained to support the ground operation.

d. The 197th Aviation Company provided flight route and surrounding area reconnaissance, LZ prestrike, marking and continuous armed overhead cover of the ground operation.

Sequence of Events

220550 Feb 66	145th Avn Bn (-) closed Bien Hoa
0600	Final Briefing
0630	145th Avn Bn C&C aircraft reported to XL, armed aircraft reported to XL, refueled
0649	145th Avn Bn (-) departed Bien Hoa
0707	145th Avn Bn (-) arrived An Loc, loaded troops
0710	145th Avn Bn (-) departed An Loc
0728-0730	Armed helcopter prestrike & mark, LZ WHITE
0730	1st Aslt Landing LZ WHITE
0814	2nd Aslt Landing LZ WHITE
0835-0905	145th Avn Bn arrived Xuan Loc refueled
0910	145th Avn Bn arrived An Loc loaded and departed
0930	3rd Aslt landing LZ WHITE
0935	Bn elements released

a. In support of the operation, the 145th Aviation Battalion committed 62 helicopters which flew 192.6 hours and 563 sorties. A total of 970 troops were lifted into the operational area. The Battalion Command and Control helicopter flew the Division Command and Control group during the air movement phase of the operation.

4. ADMINISTRATION AND LOGISTICS:

a. Supply:

(1) The Battalion POL Section displaced nine (9) fuel dispensing units to Xuan Loc on 21 February 1966, in preparation for the operation.

(2) A total of three (3) UH-1D's were required to transport men and equipment to and from Xuan Loc.

(3) A total of 10,900 gallons of JP/4 were used in support of this operation.

b. Maintenance:

(1) Maintenance representative was located at Xuan Loc throughout the operation.

(2) No maintenance or combat damage was encountered during the operation.

c. Medical:

(1) Battalion Surgeon was located at Xuan Loc throughout the operation.

(2) No casualties were reported or treated as a result of the operation.

5. COMMENTS AND RECOMMENDATIONS:

a. This operation was conducted without an artillery or Tac Air prestrike of the LZ in order to achieve maximum surprise and to keep from igniting the dry LZ grass. Armed helicopters did an excellent job of preparing the LZ one minute prior to the arrival of the lift elements. This technique varied a previously set pattern of lengthy LZ preparation, achieved maximum surprise and is highly recommended as a variation when the situation will permit.

b. The 145th Aviation Battalion demonstrated excellent flexibility and control during the operation and it was executed in a smooth and highly professional manner.

Horst K Joost

HORST K. JOOST
Lt Col Infantry
Commanding

HEADQUARTERS
145TH AVIATION BATTALION
APO San Francisco 96307

AVAW-FC

SUBJECT: After Action Report of 145th Aviation Battalion Operation 13-66,
26 February 1966

TO: Commanding General, 1st Infantry Division, APO San Francisco 96345
Deputy Senior Advisor, III Corps, APO San Francisco 96227
Commanding Officer, 12th Aviation Group, APO San Francisco 96307

1. TASK ORGANIZATION:

a. Battalion Headquarters:

145th Aviation Battalion Command and Control Helicopter
74th Aviation Company (-)
197th Aviation Company (-)

b. 1st Flight Element: 68th Aviation Company (A-1):

10 UH-1D Helicopters
5 UH-1B (Armed) Helicopters
1 UH-1B (Maint) Helicopter

c. 2nd Flight Element: A Company, 501st Aviation Battalion (A-1):

10 UH-1B Helicopters
5 UH-1B (Armed) Helicopters
1 UH-1B (Maint) Helicopter

d. Support Element:

145th Aviation Battalion Communications Section
145th Aviation Battalion Maintenance Section
145th Aviation Battalion Searcher Detachment
145th Aviation Battalion POL Section
53th Transportation Company (-)
57th Medical Detachment (Air Amb) (-)

2. MISSION: The 145th Aviation Battalion provided troop carriers, armed helicopters, surveillance and control aircraft for the 50th Regiment, 25th (ARVN) Division, in the conduct of airborne assaults in two landing zones, (LZ AIII coordinates ZS 667642 and LZ JOMI coordinates ZS 666832) vicinity 8 km northeast of Lon Luc in order to execute search and destroy operations against Viet Cong Forces, supplies, and installations.

125

3. SUMMARY OF OPERATIONS:

a. Battalion combat and supporting elements closed the Bien Hoa (SNAKEPIT) staging area 260710 February 1966 for final briefing and organization for combat.

b. Flight elements departed Bien Hoa enroute to the troop loading site (LZ MAUDE) at Ben Luc at 0816 hours. A flight route to the east of the Saigon Tan Son Nhut area had been previously coordinated with friendly artillery and the United States Air Force. The 145th Aviation Battalion Pathfinder Detachment (-) had preceded the lift elements and prepared the troops for immediate loading upon arrival of the troop carriers. A large rice paddy area 2 Km east of Ben Luc was used as a loading zone and no difficulty in loading was experienced.

c. The initial airmobile assault into LZ ANN was preceded by an intense and very effective tactical air preparation. Light enemy fire was received on approach to and departure from the landing zone as well as from the canal lines north of the landing zone. The second lift into LZ ANN was on schedule and enemy fire received was ineffective. The command and control helicopter directed tactical air and armed helicopter strikes against the areas from which hostile fire had been received.

d. Tactical air attempted to start preparation of the second landing zone (LZ JOHN) ten minutes early instead of adhering to the planned and coordination schedule; however, this was corrected by the Air Mission Commander in the Command and Control helicopter and subsequent lifts were landed on schedule and without opposition. Light fire continued to be received on the approaches to and departures from the landing zone.

e. One UH-1D (Air Ambulance) helicopter of the 57th Medical Detachment evacuated one wounded child and one ARVN soldier to Ben Luc.

f. The 74th Aviation Company provided one O-1F for radio relay, weather advisory, and surveillance throughout the operation.

g. The 197th Aviation Company provided 8 UH-1B (Armed) helicopters and conducted flight route and surrounding area reconnaissance, landing zone marking and pre-strike, and provided two light fire teams for continuous overhead cover of the ground operation.

SEQUENCE OF EVENTS

260710 Feb 66	145th Avn Bn (-) closed SNAKEPIT
0715	Final Briefing
0800	Pathfinder reported LZ MAUDE
0816	145th Avn Bn (-) departed SNAKEPIT
0820-0855	Tac Air prepared LZ ANN
0830	C&C Hcptr reported LZ MAUDE
0844	145th Avn Bn (-) arrived LZ MAUDE and loaded
0847	145th Avn Bn (-) departed LZ MAUDE

0855-0900	Armed Hcptrs marked & prostruck LZ ANN
0900	1st Aslt landing LZ ANN
0925	2nd Aslt landing LZ JOHN
0927-0947	Tac Air prepared LZ JOHN
0947-0952	Armed Hcptrs marked & prostruck LZ JOHN
0952	3rd Aslt landing LZ JOHN
1019	4th Aslt landing LZ JOHN
1045	145th Avn Bn (-) arrived SNAKEPIT and refueled; Bn elements released

h. In support of this operation the 145th Aviation Battalion provided one O-1F airplane and 44 helicopters flying 110 hours and 396 combat sorties. Two aircraft from the 145th Aviation Battalion received two hits. There was one friendly casualty among the flight crews.

4. ADMINISTRATION AND LOGISTICS:

a. Supply:

(1) Refueling was conducted at Bien Hoa for all elements prior to lift.

(2) Coordination was made with the 197th Aviation Company for refueling and rearming of armed helicopters at Tan Son Nhut Air Base, for this operation.

b. Maintenance:

(1) Maintenance representative was on standby at the SNAKEPIT throughout the operation.

(2) The following aircraft from Second Section, Second Platoon, 171st Aviation Company received combat damage as indicated.

(a) UH-1B, SN 63-8632, received a small arms round through underside of cargo compartment. Damage was minor and aircraft continued mission.

(3) The following Aircraft from A Company, 501st Aviation Battalion received combat damage as indicated:

(a) UH-1B, SN 63-12921, received small arms round through transmission and transmission cowling. Aircraft returned to home station for repairs.

c. Medical:

(1) Battalion Surgeon was located at SNAKEPIT throughout the operation.

(2) 93rd Medical Detachment provided one medical aid man with ambulance on standby at SNAKEPIT.

(3) A crew member of the 197th Aviation Company sustained IRHA when smoke grenade ignited during firing pass over LZ. This resulted in second and third degree burns to the inner thigh. Individual evacuated to 3rd Field Hospital.

(4) An RVN soldier and an indigenous person were wounded and evacuated by Dust Off.

5. COMMENTS AND RECOMMENDATIONS:

a. The ground unit did not use the standard 1st (US) Infantry Division Artillery Grid system for the control of supporting artillery fires. This grid is carried on the map of all aviators and must be used by all ground elements for safe and efficient control of artillery in the conduct of airmobile operations.

b. In this operation no consideration had been given by the ground element as to restrictions on canal or waterway traffic. It is imperative that proper coordination and control of this traffic be thoroughly planned and emphasized so that sufficient restrictions and controls on suppressive fires can be effected by the airmobile force commander.

Horst K Joost

HORST K. JOOST
Lt Col Infantry
Commanding

HEADQUARTERS
145TH AVIATION BATTALION
APO San Francisco 96227

AVAN-FC

5 March 1966

SUBJECT: After Action Report, 145th Aviation Battalion Rapid Reaction
26 February 1966, and Operation 14-66 1 March 1966

TO: Commanding General, 1st Infantry Division, APO San Francisco 96345
Deputy Senior Advisory, III Corps, APO San Francisco 96227
Commanding Officer, 12th Aviation Group, APO San Francisco 96307

1. TASK ORGANIZATION

a. Battalion Headquarters:

145th Aviation Battalion Command and Control Helicopter
197th Aviation Company(-)

b. 1st Flight Element: A Company, 82 Aviation Battalion (AML):

12 UH-1D Helicopters
5 UH-1B (Armed) Helicopters
1 UH-1B (Maint) Helicopter

c. 2nd Flight Element: A Company 501st Aviation Battalion (AML)

12 UH-1D Helicopters
5 UH-1B (Armed) Helicopters
1 UH-1B (Maint) Helicopter

d. Support Element:

145th Aviation Battalion Communications Section
145th Aviation Battalion Pathfinder Detachment
145th Aviation Battalion Maintenance Section
145th Aviation Battalion POL Section
56th Transportation Company (-)
57th Medical Detachment (Air Amb)(-)

2. MISSION: The 145th Aviation Battalion provided the necessary troop carriers, armed cover, and command and control aircraft for the 173rd Airborne Brigade air movement.

3. SUMMARY OF OPERATION:

a. The 145th Aviation Battalion was alerted for extraction of the 2/503rd Airborne Infantry Battalion by 1st Infantry Division Army Aviation Control Center; 26 February 1966.

Upon arrival of the Battalion Commander and S-3 at the Brigade Command Post, the mission was changed to a combat assault with one rifle company. The 2/503rd which had made heavy contact with the enemy was to be reinforced and remain in the assigned TAOR. Tactical Air, artillery, and Army Aviation Support was quickly planned and coordinated for the operation.

b. Flight leaders were given a briefing and all elements prepared for immediate departure from separate staging areas (assigned unit areas). Troops were loaded at the 173rd Airborne Brigade helipad and departed at 1630 hours for the operational area. Tactical air prestruck targets in the vicinity of the LZ (coordinates XT894255) and armed helicopters were used for suppressive fire during the assault landing. Light small arms and automatic weapons fire was received during the landing and numerous fires were started in the landing area. Only one lift was required to lift the assault force of 168 men and all aircraft were released at 1715 hours. In support of the operation the 145th Aviation Battalion committed 33 helicopters which flew 48.3 hours and 165 sorties. No aircraft received hits and there were no casualties among the flight crews.

c. The Battalion was again alerted 1 March 1966 for extraction of 2/503rd Airborne Infantry Battalion. The flight leaders were briefed at the Bien Hoa (SNAKEPIT) staging area at 1130 hours and all elements were prepared for the extraction. The flight elements were staged from separate locations (assigned unit areas) and joined in the air for the operation.

d. Battalion Pathfinders and the command and control helicopter proceeded the flight elements into the LZ (coordinates XT 878268) for final coordination and preparation of troops for loading. The landing zone selected by the ground unit was extremely small and only large enough to accommodate one half of each flight element (five helicopters). In addition, there were obstacles 30 feet high at the departure end of the landing zone and the density altitude was approximately 3000 feet. The flight elements were separated and cautioned about the landing zone conditions. The extraction began at exactly 1300 hours, requiring three lifts and was completed at 1415 hours. Light small arms and automatic weapons fire was received on approach and departure from the landing zone. The flight routes were adjusted to avoid the hazardous areas and armed helicopter strikes were conducted on known and suspected enemy positions. A total of 488 troops were extracted in one hour and fifteen minutes. The battalion committed 36 helicopters for the operation and flew 56.8 hours and 185 combat sorties. No aircraft were hit by enemy fire and there were no aviation crew casualties.

e. The Battalion Command and Control helicopter carried the ground command group during each operation and controlled the air movement.

13

4. ADMINISTRATION AND LOGISTICS:

a. Supply:

No supplies were required for either the assault or the extraction phase of the operation.

b. Maintenance:

No maintenance problems or combat damage was reported during the two phases of the operation.

c. Medical:

No casualties were reported or treated during either phase of the operation.

5. COMMENTS AND RECOMMENDATIONS:

Each operation, although rapidly planned, was executed in a highly professional manner without any major difficulties.

Horst K Joost

HORST K. JOOST
Lt Col Infantry
Commanding

HEADQUARTERS
145TH AVIATION BATTALION
APO San Francisco 96227

AVAW-FC

10 March 1966

SUBJECT: After Action Report, 145th Aviation Battalion Operation 16-66
3 March 1966

TO: Commanding General, 1st Infantry Division, APO San Francisco 96345
Deputy Senior Advisor, III Corps, APO San Francisco 96227
Commanding Officer, 12th Aviation Group, APO San Francisco 96307

1. TASK ORGANIZATION:

a. Battalion Headquarters:

145th Aviation Battalion Command and Control Helicopter
197th Aviation Company (-)

b. 1st Flight Element: 118th Aviation Company (AML):

8 UH-1D Helicopters
5 UH-1B (Armed) Helicopters
1 UH-1B (Maint) Helicopter

c. 2nd Flight Element: A Company, 82nd Aviation Battalion (AML):

9 UH-1B Helicopters
5 UH-1B (Armed) Helicopters
1 UH-1B (Maint) Helicopter

d. 3rd Flight Element: 68th Aviation Company (AML):

9 UH-1D Helicopters
5 UH-1B (Armed) Helicopters
1 UH-1B (Maint) Helicopter

e. Support Element:

145th Aviation Battalion Communications Section
145th Aviation Battalion Pathfinder Detachment
145th Aviation Battalion POL Section
56th Transportation Company (-)
57th Medical Detachment (Air Amb) (-)

2. MISSION: The 145th Aviation Battalion provided the necessary troop carriers, armed helicopters, and command and control aircraft for the 43rd Regiment, 10th (ARVN) Division's airborne assault from LZ BLUE (coordinates YS 398627) into LZ PURPLE (coordinates YS 501539) beginning 030800 March 1966.

3. SUMMARY OF OPERATION:

a. Battalion combat and supporting element representatives were assembled at the Bien Hoa (SNAKEPIT) staging area 030600 March 1966 for briefing prior to the operation. The flight elements were staged at four separate locations, (Bien Hoa, 173rd Abn Bde helipad, Vung Tau, and Tan Son Nhut) and converged for the operation at the forward troop loading zone.

b. Flight elements departed their respective staging areas, beginning, 030715 March for LZ BLUE. Due to an unexpected cloud layer, flight altitude was adjusted from 2000 feet MSL to 1500 feet MSL. Some difficulty was experienced by Tac Air during the LZ preparation due to the unexpected low layer of clouds; however, naval gunfire and armed helicopters were also used in the preparation and were expertly coordinated from the Command and Control helicopter. Light small arms and automatic weapons fire was received by the flight elements on approach and departure from LZ PURPLE during the initial assault. A "heavy-left" landing formation was used to position maximum army aviation fire support toward the enemy side of the LZ. Organic armed helicopters were also employed heavily on the left. Subsequent flight elements were diverted around the known enemy locations and Tac Air was directed into the area between the 1st and 2nd lifts in order to neutralize enemy fire.

c. The 2nd and 3rd and a partial 4th lift were made into the landing zone without any major difficulties. One ARVN soldier was reported injured and the aeromedical evacuation ambulance was directed into the area for casualty evacuation. Upon completion of the last lift, three troop carriers and two light fire teams were assigned to continue support of the ground operation. The remaining flight elements were released to home station at 0945 hours to prepare for normal scheduled III Corps missions.

d. The 197th Aviation Company provided 8 UH-1B (Armed) helicopters and conducted flight route and surrounding area reconnaissance, LZ marking and prestrike, and two light fire teams for continuous cover of ground operations.

SEQUENCE OF EVENTS

0600
0645
0630-0730
0715
0722
0730-0755

Final Briefing SNAKEPIT
C&C reported Xuan Loc
Naval Gun Fire
Pathfinders reported to LZ BLUE
145th Avn Bn (-) departed Bien Hoa
Tac Air prestrike LZ PURPLE

0737	68th Avn Co departed Vung Tau
0745	145th Avn Bn arrived, loaded and departed LZ BLUE
0755-0800	Armed helicopters prestruck LZ PURPLE
0800	1st Aslt landing LZ PURPLE
0830	2nd Aslt landing LZ PURPLE
0900	3rd Aslt landing LZ PURPLE
0930-1000	Bn element arrived XL and VI; refueled
1025	145th Avn Bn arrived LZ PURPLE, loaded, and departed
1040	4th Aslt landing LZ PURPLE

e. In support of this operation, the 145th Aviation Battalion committed 52 helicopters which flew 119.3 hours and 390 sorties. 977 assault troops were lifted into the operational area in 1 hour and 48 minutes. No aircraft were hit and there were no casualties among the flight crews.

4. ADMINISTRATION AND LOGISTICS:

a. Supply:

(1) Refueling and rearming of aircraft for this operation was scheduled to be conducted at Xuan Loc.

(2) Having received a warning order from the S-3, the S-4 made arrangements to transport eight (8) fuel pumping units direct from Tay Ninh to Xuan Loc on 2 March 1966.

(3) Coordination was made with 10th Division G-4 advisor for the refueling of bladders in preparation for the operation.

(4) The assistant S-4 with nine (9) enlisted men departed Bien Hoa for Xuan Loc at 0640 hours, 3 March; however refueling was not required. Equipment and men were returned to home station.

b. Maintenance:

(1) A maintenance representative was located at Xuan Loc until completion of the operation.

(2) No maintenance problems or damage was reported.

c. Medical:

(1) The Battalion Aid Station was located at Vung Tau and staffed by the 430th Medical Detachment.

(2) No casualties were reported or treated as a result of the operation.

5. COMMENTS AND RECOMMENDATIONS:

a. Troops were extremely slow in moving off the immediate landing area.

134

This is a problem of great concern since flight elements are spaced one minute or less apart during combat assaults and require immediate clearance in the area. Since the LZ and surrounding area had been heavily prestruck and armed helicopters are providing close and continuous suppressive fire during landing, it would appear to be to the friendly units advantage to aggressively move forward and retain the initiative. Delay in clearing the landing area also presents innumerable safety hazards to ground troops and approaching helicopters, in that troops may be struck by approaching aircraft or cause the aircraft to collide while maneuvering to avoid personnel on the LZ. It is highly recommended that these critical points be emphasized during training and operational planning.

b. The technique of converging distantly located flight elements in the operational area saved a significant amount of aircraft flying time and reduced refueling requirements. It also enabled early completion of the operation.

c. This operation was executed in a highly professional and smooth manner with no major difficulties encountered.

Horst K. Joost

HORST K. JOOST
Lt Col Inf
Commanding

HEADQUARTERS
145TH AVIATION BATTALION
APO San Francisco 96227

AVAW-FC

18 March 1966

SUBJECT: After Action Report, 145th Aviation Battalion Operation 20-66AA

TO: See Distribution

1. TASK ORGANIZATION:

a. Battalion Headquarters:

145th Aviation Battalion Command and Control Helicopter
197th Aviation Company (-)

b. 1st Flight Element: 68th Aviation Company (AML):

10 UH-1D Helicopters
3 UH-1B (Armed) Helicopters
1 UH-1B (Maint) Helicopter

c. 2nd Flight Element: 118th Aviation Company (AML):

9 UH-1D Helicopters
3 UH-1B (Armed) Helicopters
1 UH-1B (Maint) Helicopter

d. 3rd Flight Element: A Company, 501st Aviation Battalion:

9 UH-1D Helicopters
6 UH-1B (Armed) Helicopters
1 UH-1B (Maint) Helicopter

e. Support Element:

145th Aviation Battalion Communications Section
145th Aviation Battalion Maintenance Section
145th Aviation Battalion Pathfinder Detachment
145th Aviation Battalion POL Section
56th Transportation Company (-)
57th Medical Detachment (Air Amb) (-)

2. MISSION: The 145th Aviation Battalion provided the necessary troop carriers, armed helicopters, and command and control aircraft for the 50th Regiment, 25th (ARVN) Division's airborne assault from Duc Hoa (coord XS 590956) to LZ KING (coord XS 564847) and LZ HELEN (coord XS 533839) beginning 180915 March 1966.

3. SUMMARY OF OPERATION:

a. Battalion combat and supporting element representatives were assembled at the Bien Hoa (SHANKS) staging area 180730 March 1966 for briefing prior to the operation. All flight elements were staged from Bien Hoa except the 197th Aviation Company which staged from Tan Son Nhut.

b. Flight elements departed their respective staging areas, beginning, 180754 with the armed helicopters, less those of A Company 501st Aviation Battalion. The armed helicopters were refueled at Duc Hoa prior to the arrival of the troop carriers. Troop carriers departed Bien Hoa at 0839 with intermediate troop loading at Duc Hoa and then direct to LZ HELEN. Tac preparation was terminated five minutes prior to LZ time on LZ HELEN, armed helicopters then prestruck and marked the LZ. Light small arms fire was received by flight elements on approach and departure from LZ HELEN however its effect was minimized by excellent use of offensive suppressive fire.

c. The second and third lifts were made into landing zone KING. Enroute to LZ KING, on the second lift one aircraft from A Company 501st Aviation Battalion received one hit from small arms fire over Pont Duc (coord 533960). There were no wounded and the aircraft continued the mission. Numerous reports of small arms fire and one report of automatic weapons at (coord 550850) were received and armed helicopters were utilized to neutralize these fires. Tac air was not requested due to the proximity of friendly troops. Between the second and third lifts into LZ KING, 10 Viet Cong were reported in the open at (coord 542040) 400 meters north of LZ HELEN; armed helicopters engaged with good results. The third lift was flown at 1500 feet due to cloud cover. Upon completion of the last lift, four troop carriers and two light fire teams were assigned to continue support of the ground operation. The remaining flight elements were released to Bien Hoa at 1036 hours to prepare for normal III Corps missions.

d. The 197th Aviation Company provided six UH-1B armed helicopters and conducted flight route and surrounding area reconnaissance, LZ marking and five minute prestrike.

SEQUENCE OF EVENTS

0700	Final briefing SHANKS
0730	145th Aviation Battalion closes Bien Hoa
0815	Armed aircraft close Duc Hoa (except A company 501st Aviation Battalion)
0825-0910	Tactical air preparation
0839	145th Aviation Battalion departs Bien Hoa
0900	145th Aviation Battalion arrives Duc Hoa
0903	145th Aviation Battalion departs Duc Hoa

139

0910-0915	Armed helicopter prestrike LZ HELEN
0915	1st Assault landing LZ HELEN
0927-0930	145th Aviation Battalion arrives Duc Hoa, loads and departs
0945	2nd Assault landing LZ K NG
0957-1000	145th Aviation Battalion arrives Duc Hoa, loads and departs
1012	3rd assault landing LZ KING
1038	145th Aviation Battalion elements were released
1300	145th Aviation Battalion reverted to normal III Corps missions.

e. In support of this operation, the 145th Aviation Battalion committed 52 helicopters which flew 110 hours and 327 sorties. 689 assault troops were lifted into the operational area in one hour and twenty-three minutes. One troop carrier was hit with only minor damage and there were no casualties among the flight crews.

4. ADMINISTRATION AND LOGISTICS:

a. Supply:

Refueling was conducted at Bien Hoa for all troop carriers and at Duc Hoa for all armed helicopters.

b. Maintenance:

No maintenance problems or combat damage was reported.

c. Medical:

(1) Battalion Surgeon was located at SNAKEPIT during the operation.

(2) No casualties were reported or treated as a result of the operation.

5. COMPLAINTS AND RECOMMENDATIONS:

a. 25th (ARVN) Division was short 45 troops for second lift, this led to poor utilization of airlift capability during this lift. It is recommended that more accurate information as to the number of troops to be lifted be supplied to the airlift unit.

b. At 1000 hours an unidentified U-8 type aircraft flew from north to south at 1500 feet across both LZ's KING and HELEN. It is highly recommended that aircraft not involved in operations be restricted from operational areas as a flight hazard.

Horst K. Joost

HORST K. JOOST
Lt Col. Infantry
Commanding

HEADQUARTERS
145TH AVIATION BATTALION
APO San Francisco 96227

AVAM-FC

10 April 1966

SUBJECT: After Action Report of 145th Aviation Battalion Operation 23-66,
and 23-66A, 10 April 1966

TO: SPECIAL

1. TASK ORGANIZATION: 23-66

a. Battalion Headquarters:

145th Aviation Battalion Command and Control Helicopter
74th Aviation Company (-)
197th Aviation Company (-)

b. 1st Flight Element: 68th Aviation Company (AHL):

10 UH-1D Helicopters
4 UH-1B (Armed) Helicopters
1 UH-1B (Maint) Helicopter

c. 2nd Flight Element: 126th Aviation Company (AHL):

9 UH-1D Helicopters
4 UH-1B (Armed) Helicopters
1 UH-1B (Maint) Helicopter

d. Support Element:

145th Aviation Battalion Communication Section
145th Aviation Battalion Maintenance Section
145th Aviation Battalion POL Section
56th Transportation Company (-)
57th Medical Detachment (Air Amb) (-)

23-66

TASK ORGANIZATION:

a. Battalion Headquarters:

145th Aviation Battalion Command and Control Helicopter
74th Aviation Company (-)
197th Aviation Company (-)

b. 1st Flight Element: 68th Aviation Company (AML):

5 UH-1D Helicopters
4 UH-1D (Armed) Helicopters
1 UH-1B (Maint) Helicopter

**c. 2nd Flight Element: 162nd Aviation Company (AML) plus one from
A Company 501st Aviation Company**

5 UH-1D helicopters
2 UH-1B (Armed) Helicopters

**d. 3rd Flight Element: 116th Aviation Company (AML) plus one
from the 68th Aviation Company (AML):**

5 UH-1D Helicopters

e. 4th Flight Element: 118th Aviation Company (AML):

5 UH-1D Helicopters
(4th lift only)

f. Support Element Same as 23-66

2. MISSION: The 145th Aviation Battalion provided troop carriers, armed helicopters, surveillance and control aircraft for detachment C-3 (Mike Force). US Special Forces in conduct of airmobile assaults into LZ CUTLASS (coordinates YS 109872) in order to execute search and destroy operations against Viet Cong Forces, supplies and installations, and extracted on order.

3. SUMMARY OF OPERATIONS:

a. Battalion Combat and supporting elements closed the Bien Hoa (BLIND CAGE) staging area 100640 April 1966 for final briefing and organization for combat.

b. Flight elements loaded and departed BLINDCAGE at 0742 hours. a flight route east of the Saigon, Tan Son Nhut area had been previously coordinated with friendly artillery. 145th Aviation Battalion prestrike and 1st assault landing were six minutes late due to late tactical air prestrike. Both the tactical air and armed helicopter prestrikes were very effective. The first lift received fire from (coordinates YS 076842)

140

as they left LZ Cutlass. The fire was neutralized by Saber elements and second and third lifts were directed to change their departure heading to 110° no additional fire was received. 145th Aviation Battalion elements were released for normal missions at 0935 except for one command and control aircraft and one light fire team for the 68th Aviation Company and one heavy fire team from the 197th Aviation Company which remained to cover ground operations.

c. At 101430 April 1966 a rapid reaction was ordered to extract the same ground elements introduced in the morning operation. By 1645 all elements to be utilized closed into the SNAKEPIT staging area. A final briefing was held at 1650 hours and the first extraction lift departed the SNAKEPIT area at 1715. A total of four lifts were utilized by three flight elements to bring out 489 troops. There was no enemy opposition and the operation was handled in a very professional manner, again demonstrating the great flexibility of Army Aviation.

d. The 74th Aviation Company provided one O-1F for radio relay, weather advisory and surveillance throughout the morning operation.

e. The 197th Aviation Company provided 5 UH-1B (Armed) helicopters during morning operations and four during the rapid reaction phase.

SEQUENCE OF EVENTS

100640	145th Aviation Battalion (-) closed BIRDCAGE
0645	Final Briefing
0710-0801	Tac Air prep LZ CUTLASS
0742	145th Avn Bn departed BIRDCAGE
0801	Armed helicopters marked and prestruck LZ CUTLASS
0806	1st Aslt landing LZ CUTLASS
0826	145th Avn Bn arrived BIRDCAGE loaded and departed
0844	2nd Aslt landing LZ CUTLASS
0904	145th Avn Bn arrived BIRDCAGE loaded and departed
0922	3rd Aslt landing LZ CUTLASS
0940	145th Avn Bn arrived BIRDCAGE and was released
1430	Alerted for "High Voltage"
1645	Closed SNAKEPIT

23-66 AA

1650	Final Briefing
1715	145th Avn Bn departed SNAKEPIT for 1st extraction lift
1745	Second lift
1825	Third lift
1845	Final lift
1905	All elements were released.

d. In support of these operations the 145th Aviation Battalion provided one O-1F airplane and 48 helicopters flying 107 hours and 250 combat sorties. There were no aircraft hit and no friendly casualties among the flight crews.

4. ADMINISTRATION AND LOGISTICS:

a. Supply: Refueling consisted of aircraft refueling to maximum capacity before and after both phases of the operation.

191

Stagging was conducted at the STAKEPIT

b. Maintenance:

(1) Maintenance representative was located at the SNAKEPIT for Both phases of the operation.

(2) No damage or maintenance problems were encountered.

c. Medical:

(1) Battalion Flight Surgeon was located at the SNAKEPIT for the assault phase of the operation.

(2) Commanding Officer, 774th Medical Detachment provided 2 aidmen and ambulance on standby at the SNAKEPIT for the extraction phase.

(3) No casualties were reported or treated as a result of the operation.

5. COMMENTS AND RECOMMENDATIONS:

a. Tactical air prestrikes were very effective but caused a six minute delay in the armed helicopter prestrike and marking of the LZ. This, in turn, caused the first assault landing to be six minutes late. Recommend all elements work on same time schedule and that the air liaison officer insure that tactical air elements work within established time frames.

b. The number of troops to be lifted was given in all coordination meetings at 540 however only 498 were lifted. This resulted in six aircraft unused in the last lift. This resulted in poor utilization of available aircraft resources and places unrealistic restrictions on the support this battalion can render to other units.

HORST K. JOOST
Lt Col Infantry
Commanding

HEADQUARTERS
145TH AVIATION BATTALION
APO San Francisco 96227

AVAW-FC

19 April 1966

SUBJECT: After Action Report of 145th Aviation Battalion Operation
27-66, 18 April 1966

TO: SPECIAL

1. TASK ORGANIZATION:

a. Battalion Headquarters:

145th Aviation Battalion Command and Control Helicopter
74th Aviation Company (-)
197th Aviation Company (-)

b. 1st Flight Element: 118th Aviation Company (AML):

10 UH-1D Helicopters
5 UH-1B (Armed) Helicopters
1 UH-1B (Maint) Helicopter

c. 2nd Flight Element: 68th Aviation Company (AML):

10 UH-1D Helicopters
4 UH-1B (Armed) Helicopters
1 UH-1B (Maint) Helicopter

d. Support Element:

145th Aviation Battalion Communications Section
145th Aviation Battalion Maintenance Section
145th Aviation Battalion Pathfinder Detachment
145th Aviation Battalion POL Section
56th Transportation Company (-)
57th Medical Detachment (Air Amb) (-)

2. MISSION: The 145th Aviation Battalion provided troop carriers, armed helicopters and command and control aircraft for the 50th Regiment, 25th (ARVN) Division, in the conduct of airmobile assaults into four landing zones, (LZ 1 Coordinates XS 458760, LZ 2 Coordinates XS 464764, LZ 3 Coordinates, XS 478768 and LZ 4 Coordinates XS 487768) vicinity 12 Km north west of Tan An in order to execute search and destroy operations against Viet Cong Forces, supplies and installations.

143

3. SUMMARY OF OPERATIONS:

a. 145th Aviation Battalion combat combat and supporting elements closed Bien Hoa (SNAKEPIT) staging area 180650 April 1966 for final briefing and organization for combat.

b. Flight elements departed Bien Hoa enroute to the troop loading site (Tan An Airstrip) at 0808 hours. A flight route to the south of Saigon was chosen to conserve fuel. The 145th Aviation Battalion pathfinder and command and control elements preceded the troop carriers to insure proper coordination and immediate loading of the troop carriers.

c. The initial airmobile assault into LZ's 1 and 2 was delayed by an uncontrolled, uncoordinated air strike in the LZ areas by VNAF A-1s. These aircraft dropped white phosphorus bombs which caused numerous fires and completely obscured the LZ areas. Due to this airstrike LZ time was changed from 0900 to 0945. At 0940 during his prestrike, Saber Six (CO, 197th Aviation Company) reported mortar fire in the LZ area. These fires were coming from river assault group boats operating in the Occidental River, west of the LZ's this fire was also uncontrolled and created very hazardous conditions which caused another five minute delay in plans. From this point on the operation went as planned with 510 troops being lifted into four LZ's in three lifts. Small arms fire was received from (coordinates 424744) during the return from the first lift. At 0955 hours Mustang six (68th Aviation Company gun platoon leader) engaged an estimated Viet Cong squad at this and neutralized their fire.

d. One CH-47 from the 56th Transportation Company evacuated a UH-1D from the 118th Aviation Company which had damaged it's tail rotor.

e. The 197th Aviation Company provided 5 UH-1B (Armed) helicopters and conducted flight route and surrounding area reconnaissance, landing zone marking and prestrike on LZ's 1 and 2. Marking and prestrike on LZ 3 and 4 was executed by the 118th Aviation Company gun platoon and the 68th Aviation Company supplied two light fire teams for continuous overhead cover for the river assault groups operating in the area.

SEQUENCE OF EVENTS

180650	145th Avn Bn (-) closed SNAKEPIT
0700	Final Briefing
0808	145th Avn Bn (-) departed SNAKEPIT
0838	145th Avn Bn (-) arrived Tan An
0931	145th Avn Bn (-) loaded, departed Tan An
0945	197th Avn Co prestruck and marked LZ's 1 and 2.
0955	118th Avn Co landed LZ 1
0956	68th Avn Co landed LZ 2
1032	118th Avn Co prestruck and marked LZ 3 and 4
1037	118th Avn Co landed LZ 3
1038	68th Avn Co landed LZ 4
1118	118th and 68th Avn Co's split into five aircraft elements for landings on LZ 2 and 3
1138	145th Avn Bn (-) arrived Duc Hoa, refueled, 68th Avn Co stoodby other elements released.

144

f. In support of this operation the 145th Aviation Battalion provided 34 helicopters flying 123 hours and 249 combat sorties. There were no aircraft hit and no aircrew casualties on this operation.

4. ADMINISTRATION AND LOGISTICS:

a. Supply:

(1) Coordination was made with the G-4 advisor of the 25th ARVN Division at Duc Hoa for six (6) trucks (2½) to support the refueling operation.

(2) The battalion POL section arrived at Duc Hoa with six men and six pumps. 500 gallon bladders were loaded on the trucks and rigged for operation.

(3) A total of 45 aircraft were refueled for a consumption of 5000 gallons of JP/4.

b. Maintenance:

(1) The following aircraft received damage as indicated.

(a) UH-1D, SN 64-13700, 118th Aviation Company struck the tail boom of UH-1D, SN 65-9613, causing damage to the main rotor blades.

(b) UH-1D, SN 65-9613, 25th Infantry Division received damage to tail rotor blades and tail boom after having been struck by the main rotor blade of UH-1D, SN 64-13700.

c. Medical:

No medical support was required for this operation.

5. COMMENTS AND RECOMMENDATIONS:

a. It is imperative that the Airmobile Force Commander and his directing headquarters plan and coordinate all major aspects of the operation to include supporting fires, tactical air support, and control within the TAOR. The air mission commander supports the air mobile force commander and must, of necessity, get all information from him and coordinate the air movement at that level. Final selection of LZ's and specific employment of supporting fires and tactical air for pre-strike must be accomplished jointly.

b. That the airmobile force commander be prepared to discuss all aspects of the operation at the final coordination meeting to insure safe and timely execution of the air movement. That the air mobile force commander have control of all elements within the TAOR which support the air landed force or which have the capability of interfering with the air movement through use of unscheduled or unannounced fires.

Horst K. Joost
HORST K. JOOST
Lt Col Infantry
Commanding

145

HEADQUARTERS
145TH AVIATION BATTALION
APO San Francisco, 96227

AVAW-FA

21 March 1966

SUBJECT: Proposed Expansion of the Battalion Civic Action Program

TO: See Distribution

1. PURPOSE: The purpose of this plan is to outline the needs, objectives and methods to expand the Battalion's Civic Actions and increase its sphere of influence in the local communities.

2. DEFINITION: Civic Action can be defined as "the use of military forces on projects useful to the local populace, such as education, training, public works, agriculture, transportation, communication, health, sanitation and other projects which contribute to the economic and social development of the country".

3. OBJECTIVES: The objectives of civic action projects are threefold. The first objective is psychological and seeks to gain and maintain the support of the people for the Government of Vietnam (GVN). Through constructive rehabilitation projects the loyalty and respect of the populace for the GVN can be developed, thus accomplishing the long range goal of establishing a self-sufficient government. Secondly, to improve the living conditions of the people so as to remove one of the basic underlying causes of insurgency. Civic actions oriented toward improving the standard of living provide tangible evidence to the populace that the US Military is interested in their welfare and is here to help them. Thirdly, through a carefully considered and balanced civic action program, the battalion may reap intelligence information from the populace concerning the Viet Cong's intentions against the United States and ARVN forces. Although not the primary reason for our assistance, this alienation of the populace will deny the Viet Cong the free access he has enjoyed in the outlying areas.

4. The Need for Civic Action:

a. In Vietnam, nearly 90% of the population are farmers who live in poverty, ignorance and superstition. In addition they have been exploited by the government and abused by the military. They were easily influenced by the Viet Minh and Viet Cong with the promise of the better life. Only recently has the Saigon government made any progress in winning the people away from supporting or tolerating the Viet Cong. This was accomplished through a counter-insurgency plan which Civic Action is one of the basic components.

b. The people of Vietnam have been carrying on their struggle for approximately 20 years. Their record of bravery and gallantry is written in the pages of military history. However, their struggle has resulted in a tremendous regression in economic and social growth. Consequently the populace as a whole still lives in abject poverty. Many of them have been displaced as a result of combat operations, either voluntarily or involuntarily. Other ethical groups have come to Vietnam in search of freedom. The one basic fact that they all have in common is an overwhelming desire to improve their status economically and socially. However, they are refugees and as such have few worldly possessions, or the capacity to produce consumer goods. They have established communities under the control of the Government of Vietnam.

c. It must be recognized that the GVN is relatively young by United States Standards. Although the government has assumed its responsibility of providing for all its people, it does not have the capability of providing this support or creating an economy that will ultimately lead to a higher standard of living without the help of the United States.

d. The magnitude of this refugee problem is best illustrated by the current situation in the Bien Hoa province, but is applicable to all refugee areas in Vietnam. Immediately east of Bien Hoa proper is the Ho Nai refugee camp. The population is in excess of 80,000 and refugees are arriving at the rate of 250 per day. The government has helped these people build shelters and establish communities but the economic development has not kept pace with the expanding communities. Consequently the communities are in name only and do not represent communities as we know them, with schools, water systems, sewage systems, roads and industries.

5. DEVELOPMENT: a. The Battalion has conducted civic actions in the past but not of a magnitude commensurate with its resources. In our expansion effort the focus will be on improving our community relations on an individual daily basis, increasing the support that is currently being provided to local orphanages and expanding our civic actions program to include common projects, and MEDCAP activities in the local communities.

b. Community Relations: Our greatest strength lies in the individual soldier. Each member of the battalion must act as an ambassador of good will. One act of misconduct or violence can cause a feeling of resentment toward all Americans. One act of kindness can foster Vietnamese American relations and reap untold rewards. In this connection, each member of the Battalion must be oriented toward his responsibility in dealing with the Vietnamese Nationals.

c. Orphanage Support: From time to time each unit has had sole or joint sponsorship of an orphanage. Relocation of company size units has caused continuity problems, however, orphanage support has been one of the major projects in the past. Now that the Battalion and subordinate units are in a static position, or as static as the fluid tactical situation allows, definitive arrangements should be made, where practicable, for each company to support an orphanage located a reasonable distance from its geographic

location. There are unlimited opportunities to distribute food stuffs, clothing, and other luxury items either donated by members of the Battalion or supporters from the United States. However, this association with orphanages is not coordinated through the GVN and even though it does improve the image of the United States military it does not accomplish the ultimate objective of winning the populace to the Vietnamese Government. For this reason it is anticipated that the Battalion's greatest effort will be in the area of common projects.

d. Common Projects: Common projects will be accomplished by units of the Battalion in their respective local areas in conjunction with Vietnamese Nationals. For this reason the program of community support through common projects will be discussed separately by areas.

(1) Bien Hoa: 145th Avn Bn Hq and Hq Det

118th Avn Co

197th Avn Co

A/501st Avn Bn

(a) Coordination was made with the Province Chief through his American counterpart to ascertain the greatest needs in the Bien Hoa province. The Province Chief evaluated the needs, our resources and location and suggested that the Battalion work in the Duc Tu subsector which contains the Ho Nai refugee area and separate refugee camps. Major Rasmussen, Duc Tu Subsection advisor, in conjunction with his counterpart, the Subsector Chief, chose the Xu Bui Vinh parish for the Battalion to sponsor. Since many units work in the Duc Tu subsector, the advantages of a specific unit working in a specific hamlet or parish were pointed out. Also the parish is reasonably accessible as shown by sketch, inclosure 1. Another obvious advantage of working on a long term basis with one specific parish is that rapport is immediately established and as the relationship improves with the passage of time, continuity adds a feeling of mutual respect and trust.

(b) Father Doan Kin Thanh is the parish chief. The parish has approximately 7000 inhabitants with more arriving each day. The people are from various ethical and religious backgrounds with approximately 3000 Catholic and 4000 Protestant, Buddhist and other occidental and oriental religions. This refugee center has been established since the early 50's and has made a great effort to improve its standards of living. An example of their desire to improve is the school which they are building at present. Through their own resources they are making the cement blocks to build a 5 room school. It goes without saying that they could use and would appreciate help in this project.

(c) Paper work has been submitted to field a MEDCAP II team in the parish. The battalion team of two medical aid men will treat on regular visitations, starting with one per week. In conjunction with this MEDCAP II program a milk distribution will be initiated. The dry milk will be obtained through USAID and given to the children for health purposes. The milk program will be rotated among the subordinate units in Bien Hoa to supply transportation, personnel and containers.

148

(d) There is no limit to the projects that can be accomplished in the parish. Father Thanh has been told that we want to help in all civic areas such as, construction, health and sanitation, transportation, education and training, community relations, etc. etc. At present there is a need for the construction of three (3) wells strategically placed in the parish. This construction will be self help common projects.

(e) In the area of education there is much work to be done. Approximately seven hundred (700) children go to school in class rooms designed for three hundred (300). They do not have adequate desk facilities or school supplies. Also many children cannot go to school because their parents cannot afford to send them. Most of these children's parents are widows or newly arrived refugees. It costs thirty (30) piasters per month per child. Father Thanh provides money to allow some of these children to attend, but his resources cannot take care of them all.

(f) Father Thanh has many old people and blind people who are incapable of taking care of themselves. At present they do not receive any support from the Social Welfare Agency of the GVN. The ultimate plan is to provide assistance through a form of social security. In the meantime they need food, clothing and help in improving their living quarters. Father Thanh will make his wishes known through the S-5 and the S-5 will solicit help from the units. In addition, company commanders and company civil affairs officers should coordinate directly concerning any project that the company would like to undertake maintaining company integrity. Each man in the Battalion should feel free to visit the parish, talk to Father Thanh and offer assistance. Once the men actually observe the poverty, they immediately become interested in helping, in the American tradition. This has prompted many letters to charitable organizations, social groups and individuals in the United States requesting drives to obtain vitally needed items of clothing and cleaning products to be distributed to the needy. Contact will be made with local ARVN units to enlist their support in common projects. In the past the most successful projects have been common projects utilizing common labor from ARVN units and US military technical advise and assistance.

(g) It must be remembered that all our projects in the parish will be common projects with the sanction of the Parish Leader, Father Thanh. Our accomplishments in developing their economic and social status will foster the relationship between the people and the GVN. Father Thanh is the government representative and hopefully will be able to care for his people as the Government becomes stronger and expands its role.

(2) Vung Tau: 68th Avn Co

(a) Since the arrival of the 68th Aviation Company in Vung Tau, coordination has been made with the Vung Tau advisor's office seeking suitable civic action projects. A list of proposed projects was submitted for approval but due to administrative delays it was not provided to the US units until recently. This prompted the 68th Avn Co to seek a hamlet or

village outside the Vung Tau sub-sector to sponsor. Through visits and coordination with the Vung Tau subsector advisor it was decided to sponsor Can Gio. (Located as shown sketch, inclosure 2).

(b) Can Gio is highly suited for sponsorship since the only American influence, at present, is a seven (7) man US advisory team. By virtue of its geographic location and Viet Cong influence in the surrounding area, US units have not been able to provide any support to this remote village. Travel to and from Can Gio must be by air. Can Gio has a population of 3000 people comprised of refugees and fisherman. Plans include the integration of three (3) nearby villages into the civic action program thereby increasing the US area of influence. The total population affected would then be 6000.

(c) Coordination with the US sector advisor and counterpart revealed a desire to receive help in the following areas:

1. MEDCAP II visitation on a scheduled basis
2. English classes to be held twice weekly
3. Training and technical assistance in carpentry, brick laying, building, etc.
4. Transportation of materials from Saigon that are provided under the Self Help Program.

(d) In addition to these projects, a vigorous campaign to improved health and sanitation will be initiated. This will include sanitation and health education, and projects to eradicate filth and disease.

(e) Various members of the unit have initiated home town drives by civic, religious and social groups which will produce food stuff, clothing and cleaning products to be donated through the village officials to the people.

(3) Phu Loi: 74th Avn Co

(a) In the Phu Loi area liaison has been established with the civic actions coordinator, Captain Tokushige who is in charge of all projects conducted in the subsector. Many units are working in the civil affairs field, however he indicated he has immediate needs which the 74th Aviation Company can fill.

(b) Civic Actions will be undertaken based upon the availability of personnel and materials in the following areas:

1 Education: Two volunteers are needed to conduct English classes in Phu Cuong on Tuesdays and Thursday for two hours each night.

2 Community Relations: Two volunteers with former Boy Scout experience are needed to organize a scout troop in the local

community and to train Vietnamese boys in Scout handicrafts and skills.

3 Construction: a. Three volunteers are needed to aid in constructing better quarters, improving sanitation and aiding in transportation of supplies and materials for a platoon of Popular Forces near Phu Loi.

b. Considerable help is needed in an ambitious project to construct a one-hundred (100) family refugee center within the perimeter of Phu Loi air field. At least 3 or 4 men are needed to supervise and assist in construction of quarters, sanitation facilities, water supply and lighting. The land has been acquired and materials will be produced locally with the program being largely self-help. Some financial aid will be required but will be minimal. It was stressed by the area coordinator that the most pressing need is for personnel to volunteer thier time.

c. In addition to the above listed projects, Capt Tokushige stated that there are numerous other civic action projects taking place in the local area. Supplies and materials are not a problem, but American ingenuity and drive are needed. Captain Tokushige has arranged appointments with the subsector advisor and various ARVN commanders to introduce the 74th Civil Affairs Officer to establish direct liaison in expanding the unit's civic action activities.

6. The main objectives of Civic Actions are to gain and maintain the support of the people for the Government of Vietnam (GVN) and to improve the living conditions of the people. The Battalion's expansion program to include improving community relations, increasing orphanage support and undertaking common civic action projects will contribute to the ultimate goal of economic and social development of Vietnam. We are only limited by our imagination, ingenuity and generosity to provide support through a myriad of civic action projects.

FOR THE COMMANDER:

2 Incl

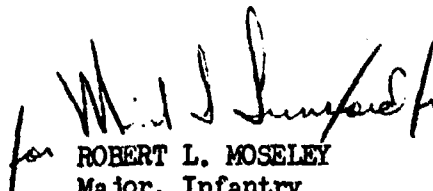
for 
ROBERT L. MOSELEY
Major, Infantry
Adjutant

DISTRIBUTION

"A" Plus
1- USARV
1-12th Avn Gp

SCALE 1:50 000

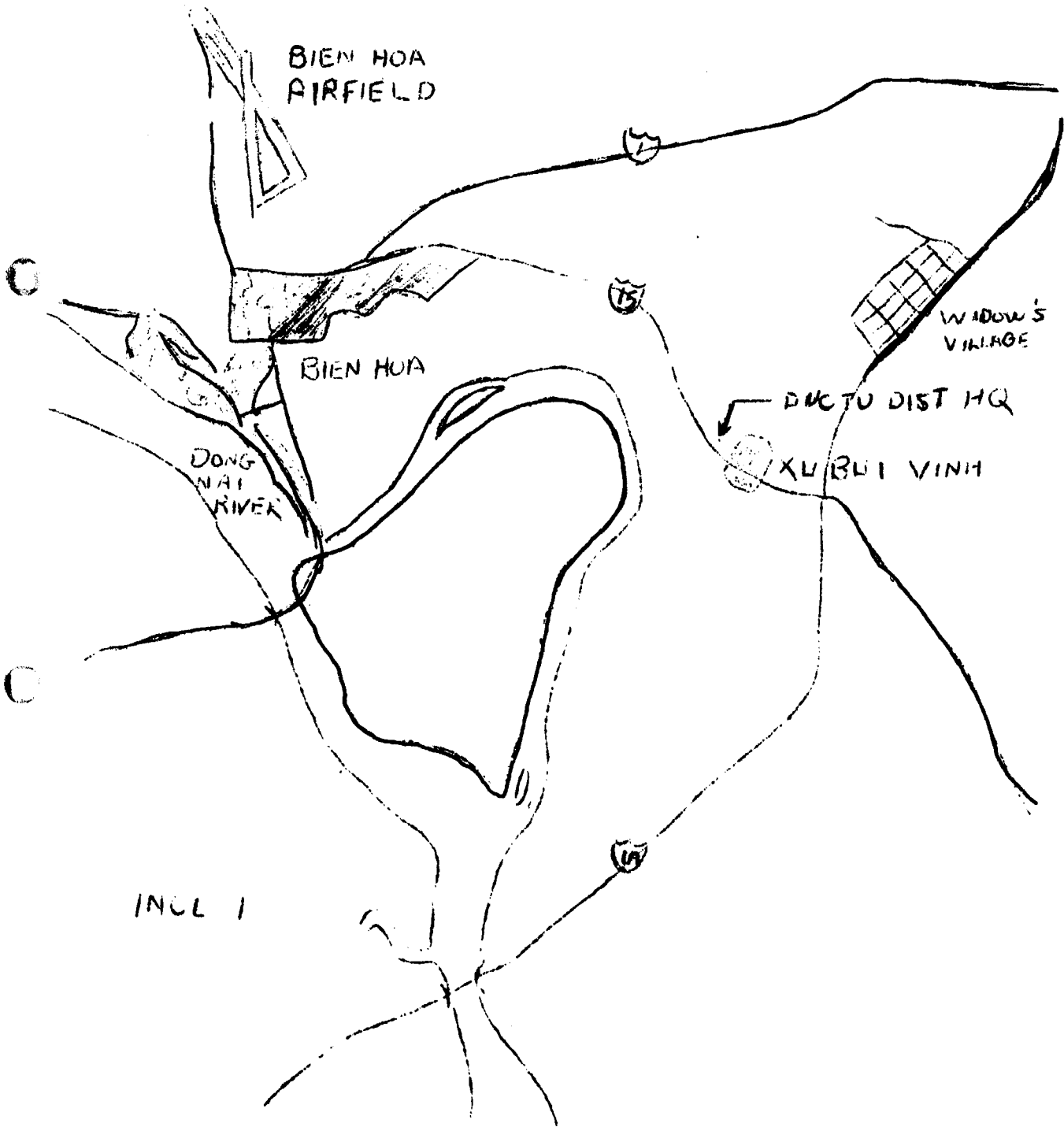

INCL 1

SCALE 1:50 000
5 0 5 10 15
STATUTE MILES

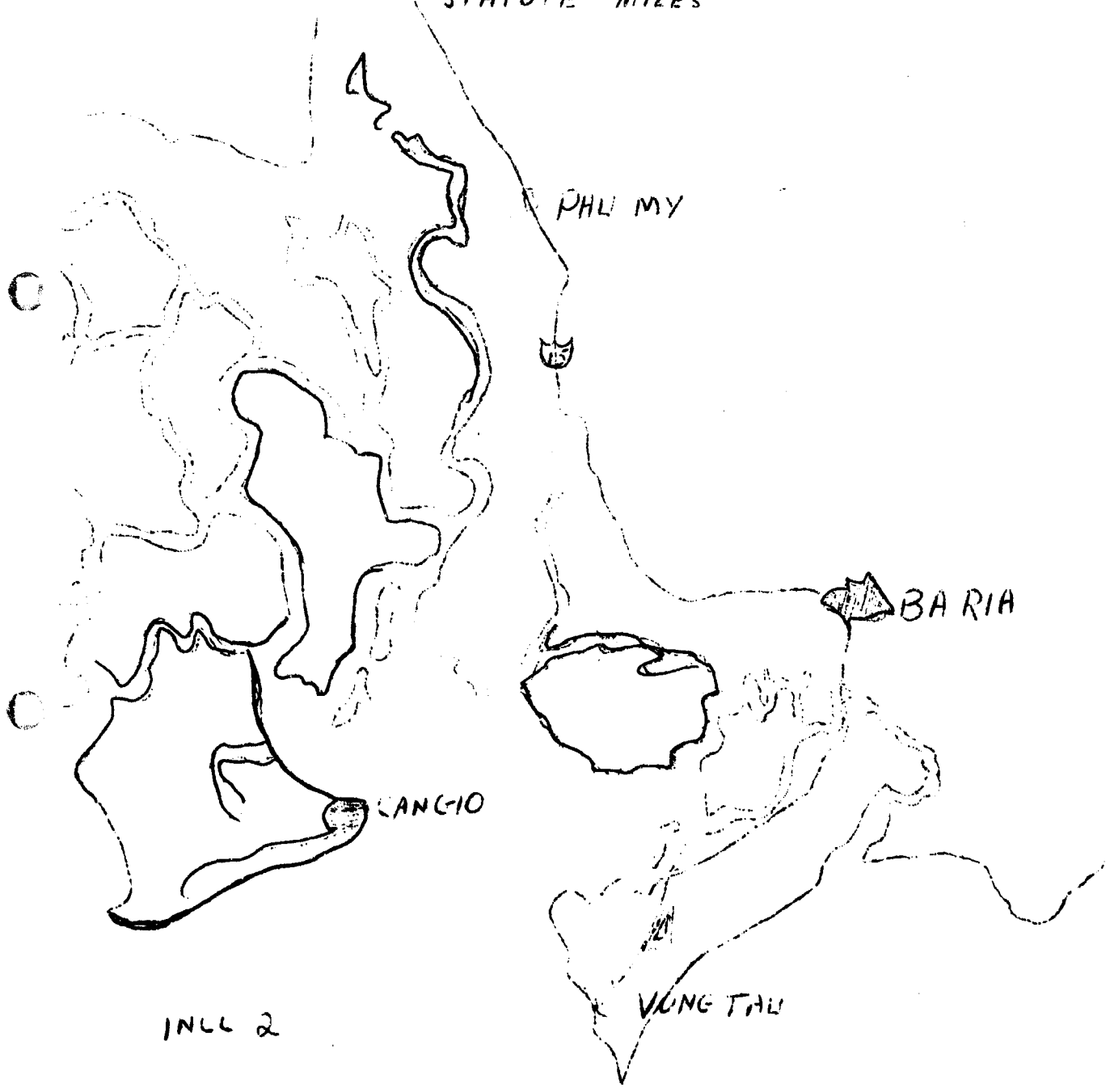

INLL 2

153

145 TH AVIATION BATTALION

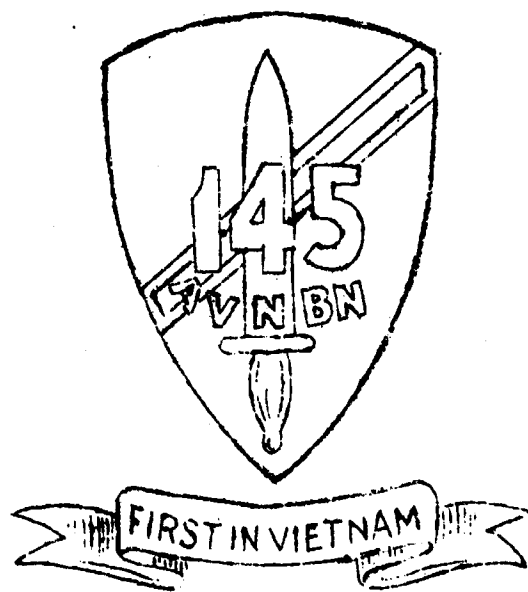

STANDING OPERATING PROCEDURES FOR AIRMOBILE OPERATIONS

TABLE OF CONTENTS

AIRMOBILE OPERATIONS:

1. General
2. Mission Assignment
3. Mission Planning
4. Mission Execution

ANNEXES:

1. Annex A - Intelligence
2. Annex B - Liaison Officer's Check List
3. Annex C - Downed Aircraft Procedures
4. Annex D - Administration and Logistics
5. Annex E - Communications
6. Annex F - Helicopter Formations
7. Annex G - Artillery Corridors
8. Annex H - Command Post and Stagefield Organization and Procedures
9. Annex I - Operations Briefing
10. Annex J - Flight Commander's Debriefing
11. Annex K - After Action Report Format
12. Annex L - Preplanned Operations
13. Annex M - Offensive and Suppressive Fire
14. Annex N - Chemical Delivery
15. Annex O - Pathfinder Operations
16. Annex P - Landing Zone Preparation
17. Annex Q - Night Operations
18. Annex Z - Distribution

Acknowledge:

JOOST
Lt Col

OFFICIAL:

Sauers
SAULS
S-3

155

FOR OFFICIAL USE ONLY

STANDING OPERATING PROCEDURE
NO. 6

AIRMOBILE OPERATIONS

1. GENERAL

a. References:

- (1) FM 1-5
- (2) FM 1-60
- (3) FM 57-35
- (4) FM 101-5

b. Purpose. This SOP standardizes all 145th Aviation Battalion units operational procedures and expedites planning, facilitates control, and insures timely, professional execution of airmobile operations.

c. Definitions:

(1) Air Mission Commander: The Aviation Unit Commander or his designated representative will be the air mission commander and will exercise command over the helicopter support portion of the operation.

(2) Chalk Number: A single aircraft or aircraft load within a flight element.

(3) Eagle Flight (Annex L): Heliborne infantry troops either on air alert over predesignated area or on immediate ground alert to perform immediate search and destroy operations, or otherwise provide the ground commander with a highly mobile and responsive strike force.

(4) Extraction Zone: A landing site jointly agreed upon by the ground commander and aviation commander where troops will be loaded aboard aircraft.

(5) Flight: Two or more elements with a common mission under the control of a single commander, usually one company size unit.

(6) Flight Element: Two or more aircraft under the control of a single commander.

(7) Forming Turn: A turn executed after takeoff to permit aircraft or elements to join in formation or gain separation.

(8) Landing Zone (LZ): An area jointly selected and approved by the ground commander and aviation commander where troops will be landed.

(9) Lift: One movement of loaded troops by a complete flight from one type of zone to another.

(10) Pick-Up Zone: A landing site, jointly agreed upon by the ground commander and aviation commander, where troops will be loaded aboard aircraft for purpose of entry into an operation.

(11) Rapid Reaction: Emergency commitment of standby armed fire teams, troop carriers or other aircraft. Standby aircraft are to be off the ground within five minutes, enroute to the assigned area. Also used in conjunction with the emergency recall of battalion aircraft for employment in support of tactical emergencies.

(12) Stagefield: A pre-determined area, usually an airfield or heliport, where aircraft assemble prior to commitment on an airmobile operation. A stagefield will normally have refueling and rearming facilities, a stagefield control party and command post operating facilities.

(13) Vector Aircraft: A fixed or rotary wing aircraft used to guide helicopter formations to landing zones, mark landing zones, perform radio relay and give weather advisories.

(14) Sortie: One sortie is one aircraft making one take off and one landing for the purpose of loading personnel, ordnance, or fuel; however, armed helicopters escorting troop carrying helicopters will log a sortie in the landing zone on combat assault operations whether or not they actually land.

(15) Task: A single definite accomplishment by one aircraft i.e., one helicopter delivering cargo to four locations. In this case the aircraft would report four sorties and one task upon termination of its mission.

(16) Mission: The dispatching of one or more aircraft for the accomplishment of a specific task or tasks.

d. Types of Missions:

(1) Pre-planned Airmobile Assault:

Lift of troops into an insecure LZ. Enemy resistance is expected during the approach, landing, or departure. Normally, empty troop carriers and unnecessary personnel will not be committed into an objective area.

(2) Troop Repositioning: Lift of troops from a secure loading zone to an LZ that is relatively secure.

(3) Troop Extraction: Lift of troops from an operational area (LZ) to a secure staging area or landing zone. LZ secured by lifted unit. Enemy resistance may be expected on last lift.

(4) Repetitious Assaults: Lift of a number of self-contained fighting elements over a large area of operations in a short period of time, with a minimum debilitation of infantry elements.

(5) Tactical Emergency Recall and Commitment of Aircraft:

(a) In the event a tactical emergency occurs within the III Corps Tactical Zone, necessary aircraft will be recalled from assigned missions in order to provide required airmobile support as directed by the supported unit. Aircraft to be used during tactical emergencies will be designated daily by the Battalion Operation Center when daily missions are assigned to units.

(b) All available communications channels will be used for emergency recall of aircraft based on the following priority:

1. III Corps TOC and II FFV channels to ground units.
2. Capital Center flight following facility.
3. Battalion Command UHF and FM radio nets.
4. Company Command UHF and FM radio nets.
5. Other

(c) Aircraft being recalled will be designated by tail or chalk number. Text of message will be:

"(Unit Aircraft Call Sign)", Assemble SNAKEPIT (or other designated Location), HIGH VOLTAGE".

HIGH VOLTAGE will indicate that an emergency exists in the III ARVN Corps Tactical Zone. Designated aircraft will terminate assigned mission as rapidly as possible and proceed with maximum speed to the assigned area, refuel, arm, and line up company element as follows:

<u>UNIT</u>	<u>ROW</u>
A/501st Avn Bn (AML)	1
(attached units)	
56th Trans and 57 Med	2
118th Avn Co (AML)	3
68th Avn Co (AML)	4
197th Avn Co (Armed)	PSP Area
74th Avn Co (ASL)	On station 6000' ISL

The Battalion Operations Center will notify company operations for battalion units, 56th Transportation Company, and 57th Medical Detachment for the attachment of maintenance recovery and medical evacuation aircraft. Units will assemble organic maintenance aircraft as part of their task organization.

(d). Flight commanders will remain at designated staging area or proceed on order to forward CP for receipt of the combat order. Assistant flight leaders will ready flight elements for immediate departure from staging area and rendezvous on order at assigned check point for further instructions and employment. The 1st Infantry Division Artillery Grid System will be used to designate rendezvous points and detailed areas of interest. Final vectoring and marking of LZ's will be directed and controlled from the Command and Control helicopter.

(e) All aircraft will monitor Battalion Command or Capital Center UHF radio frequency at all practicable times in order to comply rapidly with emergency recall instructions.

(f) Battalion support elements will proceed to the staging area or alternate Command Post as announced.

2. MISSION ASSIGNMENT

a. The 145th Aviation Battalion is assigned to 12th Aviation Group. The Battalion has been directed by 12th Aviation Group to render direct combat aviation support to III ARVN Corps and 173rd (US) Airborne Brigade or to reinforce other aviation units as directed.

b. Missions will normally be assigned to the battalion by the 12th Aviation Group, Army Aviation Element, II Field Forces Victor through the 145th Aviation Battalion, Battalion Operation Center.

c. For missions involving fifteen troop carriers or less, this headquarters will assign the mission to a company commander. Signal, logistical, and pathfinder support will be provided by this headquarters as required.

d. For missions involving sixteen or more troop carriers, this headquarters will plan, coordinate, and control the operation as a battalion effort.

3. MISSION PLANNING

a. Preliminary liaison will be effected by this headquarters. Additional follow up planning will be accomplished by the subordinate unit to which the mission is assigned if the mission is determined to be less than battalion size.

b. Liaison officers will use the Liaison Officers Checklist (Annex B) in the preliminary planning stages to facilitate complete coordination with ground and air units.

c. A visual reconnaissance of the LZ's to be used will be conducted jointly by the army aviation and ground units concerned immediately following preliminary coordination to facilitate finalizing ground and air movement plans as early as possible. Aerial photos will be requested for all landing zones.

d. This headquarters will prepare an operation order and briefing for all missions to be controlled by battalion. Subordinate units will prepare detailed operational briefings for their participating personnel.

e. Logistical, maintenance, pathfinder support, planning, and preparation will be accomplished by this headquarters.

4. MISSION EXECUTION

a. Staging Area: This headquarters will establish and control all stagefields as outlined in Annex H.

b. Air Movement Phase:

(1) In company size operations the mission commander will normally be the company commander. He will be in command of the aviation elements employed in the airmobile operations. Battalion S-2 and S-3 personnel will be available to assist in coordination and control as required and directed by the mission commander. Formations, altitudes routes, employment of pre-strike, suppressive fire, and vector control aircraft will be determined by the mission commander in coordination with the ground commander. Each airmobile light company committed outside of the III ARVN Corps Tactical Zone will have one Ol-F aircraft attached.

(2) In battalion size operations the 145th Aviation Battalion Commander will normally be the mission commander. He will designate a lead or base element, establish responsibility for navigational control, and designate battalion formations. Unless otherwise specified, companies will fly in a formation of V's of three, in trail with organic armed escort. Normally a one minute interval between companies will be used. Within the limits of control necessary to insure a coordinated battalion effort, companies will be given mission type orders and employed as elements retaining tactical unit integrity.

c. Air Landed Phase:

(1) Prior to landing in the LZ, artillery and/or tactical air will be employed to neutralize enemy forces in landing zone area. This preparation will terminate 5 minutes prior to landing of initial troop units. (Annex P).

(2) As the artillery and tactical air preparation ceases, armed helicopters will initiate visual reconnaissance of the LZ, deliver suppressive fires as needed, and mark the LZ to insure minimum ground fire by enemy forces during landing of the troop elements. The armed helicopter leader reconnoitering and marking the LZ will report enemy information, LZ condition, recommended approach and departure procedures and suppressive fire information to the air mission commander.

(3) As the lead elements of the troop carriers approach the LZ, armed helicopters engaged in the reconnaissance will shift to areas away from the LZ.

Armed escort helicopters will assume the suppressive fire role while the troop carriers are landing, unloading and departing the LZ. Lead aircraft of each flight element will drop two smoke grenades to mark the LZ upon their departure unless directed otherwise.

(4) The mission commander will insure that, whenever possible, all troop elements land and depart in formation to decrease exposure to hostile fire and facilitate the suppressive fire mission of the escort aircraft. The standard to be achieved is simultaneous touchdown and takeoff of all aircraft, with maximum of 10 seconds on the ground.

(5) Upon return to the staging area between lifts, units will send a designated representative to the Battalion Forward CP to report personnel and equipment status, enemy activity, and receive additional coordinating instructions.

(6) The Battalion Command and Control (C&C) helicopter will normally carry the airmobile force commander, air liaison officer, and an artillery representative in order to control, adjust, and coordinate the operation as a self contained and complete airborne command post. The C&C helicopter will be flown by the Aviation Battalion Commander and the Battalion S-3 or designated representatives. Company operations officers will report to C&C aircraft when elements are on the ground at staging areas and intermediate landing zones.

5. REPORTS

a. All flight element leaders will report departure from stage-fields, arrival at assigned aircraft control points (ACP) inbound to the objective area, enemy fire information, and any change in flight element status.

b. All aircraft commanders are responsible for prompt, accurate completion of after action reports.

Acknowledge

JOOST
Lt Col

OFFICIAL:

SAUERS
S-3

Hq, 145th Avn Bn
Bien Hoa, Vietnam
15 April 1966

ANNEX A: (Intelligence) to 145th Aviation Battalion SOP for Airmobile Operations.

1. GENERAL

The Intelligence Section is responsible to the Air Mission Commander for all matters pertaining to weather, terrain and the enemy situation.

2. MISSION PREPARATION

a. Coordination. As soon as possible after receipt of an airmobile mission a representative of the Intelligence Section, with a representative from Operations, will coordinate directly with the supported unit. At the initial coordination the Intelligence representative should familiarize himself with the general ground tactical plan, area of operations, date of operation, and locations of the proposed LZs. From the supported Intelligence Section he should ascertain all the information he can concerning enemy operations in the area, recent weather and the nature of the terrain. Current INTSUMS, PERINTREPS, Intelligence Estimates and study of the enemy situation map of the supported unit all contribute to gaining information.

b. Reconnaissance. After initial coordination a reconnaissance of the area of operations is conducted to select the LZs. Recommendations are made to the Airmobile Force Commander for the location of the LZ based on the terrain, weather forecast, and enemy situation.

c. Aerial Photographs. As early as possible during mission planning requests will be made for aerial photographs of the Landing Zones.

d. Weather Briefing. Coordination will be made with the US Air Force Weather Detachment to obtain forecast weather information for the area of operation. Particular emphasis should be placed on information concerning restrictions to visibility, ceiling if there is one, maximum density altitude and wind direction and velocity.

e. Enemy Information. All sources available should be researched to gain information of the enemy. As a minimum the following should be reviewed.

- (1) INTSUMS
- (2) PERINTREPS
- (3) Hit report map
- (4) Information from supported units
- (5) Order of Battle
- (6) Other sources

3. BRIEFING

Prior to every operation a minimum of an oral briefing will be conducted with key personnel to disseminate all information listed in paragraph 2 above.

162
F O R O F F I C I A L U S E O N L Y

The terrain will be discussed, especially in the area of the LZs, to include size, obstacles and condition of the ground. The weather forecast will include as a minimum those items listed in paragraph 2d. The information of the enemy will emphasize automatic weapons positions, anti-aircraft weapons positions, and previous reports of ground to air fire. Time permitting, a written Intelligence Annex will be prepared.

4. MISSION EXECUTION

During the conduct of an airmobile operation the Intelligence Section will maintain an enemy situation map. Monitoring of the operation will be continuous to gain enemy information. Based on reported information (Spot Reports) of the enemy personnel, positions, structures, transportation routes and facilities the Intelligence Section will be prepared to recommend to the Air Mission Commander changes in flight altitude, routes and Landing Zone locations.

5. DEBRIEFING

Upon completion of an airmobile operation all information of the enemy should be sent to the Intelligence Section as expeditiously as possible for processing and dissemination. Aircraft fired at or hit by enemy fire will report:

- a. Location (six digit coordinates)
- b. Type and number of weapons
- c. Intensity and accuracy
- d. Speed, altitude, direction of flight of aircraft
- e. Damage to aircraft and crew injuries
- f. Action taken

JOOST
Lt Col

DISTRIBUTION: Annex Z

OFFICIAL:

De France

DE FRANCE
S2

FOR OFFICIAL USE ONLY

A2

163

Hqs, 145th Aviation Battalion
Bien Hoa, RVN
15 April 1966

ANNEX B (Army Aviation Liaison Officers Checklist) to 145th Aviation Battalion
SOP for Airmobile Operations.

1. Name of operation and duration: _____
2. Units to be lifted:
3. No of troops to be lifted per unit:
4. No of lifts:
5. Stagefield or Loading Zone (Secure):
6. LZ Location and time:
7. Alternate LZ's:
8. Ground Tac Plan:
9. Enemy situation:
10. Mission (s) after the lift:
 - a. O-1F
 - b. UH-1's (Troop Carriers)
 - c. UH-1's (Armed)
 - d. C&C Helicopter
11. Suppressive fire restrictions:
12. Recon restriction:
13. Weather delay:
14. Photo coverage:
15. Reserves:
16. Reserve to be used in the event of downed A/C:
17. Artillery support:
 - a. Fire support plan
 - b. Arty location
 - c. Emergency lifting
18. Naval Fire Support:
 - a. Type
 - b. Fire support plan
 - c. Emergency lifting
19. Air Support:
 - a. Type A/C
 - b. Ordnance requested
 - c. Mission
 - (1) Pre-strike
 - (2) Escort
 - (3) Air Cap

FOR OFFICIAL USE ONLY

164

20. Offensive Fire:

- a. Targets
- b. Clearance
- c. Supports ground tactical plan
- d. Supports future operations
- e. Supports cover and deception

21. Communication Coordination to Include (SOI Extract)

22. Friendly Troop Identification:

23. Special check point system or codes:

24. Airmobile Force Commander

25. Observer requirements:

NO

P/U POINT

a. UH-1's (Armed) _____

b. O-1F _____

26. A/C Required:

a. UH-1D (s) _____

b. UH-1B (Armed) _____

c. C&C Helicopter _____

d. O-1F's _____

e. Dust Off _____

f. Maintenance _____

27. Border Operation (Compliance with MACV Dir 95-2 (S))

28. Pathfinder requirements:

29. Deception Plan:

30. Medical Evacuation Location:

31. S3 Coord with:

CO & XO

S2

S4

BOC

Maint

Commo

Acknowledge

JOOST

Lt Col

OFFICIAL:

Sauers

SAUERS

S-2

FOR OFFICIAL USE ONLY

165

HQ 145th Aviation Battalion
Bien Hoa, RVN
15 April 1966

Annex C (Downed Aircraft Procedures) to 145th Aviation Battalion SOP
for Airmobile Operations

All rescue and recovery operations involving downed Army Aircraft in III ARVN Corps will be coordinated through ~~Battalion Operation Center~~, (BOC), 145th Aviation Battalion. BOC will schedule daily Emergency Standby aircraft in support of III ARVN Corps.

1. BOC will perform the following steps upon notification of a downed aircraft.
 - a. Alert Emergency Standby aircraft with fire team.
 - b. Coordinate with III Corps Air Support Operations Center for strike aircraft to cover site of downed aircraft, and ground unit security forces.
 - c. Notify designated organizations of all known information. (Appendix 1).
 - d. Coordinate, as necessary, with Search and Rescue.
 - e. Coordinate, with II FFV Army Aviation Element (AAE), for troops to secure the downed aircraft.
2. The Flight Commander will be responsible for the following steps:
 - a. Evacuate and secure the downed aircraft with his available resources.
 - b. Notify BOC, 145th Avn Bn of downed aircraft by the most expeditious means possible. (Paris Control, 145th Flight Following, radio relay thru some other aircraft, telephone to 12th Aviation Group AAE, or 145th BOC). Include as much information as possible. Any request for assistance needed will be forwarded to BOC for coordination.
 - c. Determine the extent of damage and what action is necessary to recover the aircraft. If parent unit is unable to locally recover, request assistance from 145th Avn Bn Maint Officer through BOC.
3. When US personnel cannot be left in the area of downed aircraft the following critical items will be removed.
 - a. SOI extract and other sensitive cargo items
 - b. Automatic Weapons
 - c. Personal Weapons
 - d. Communications equipment, to include survival radios (URC-4 or URC-10)
 - e. Ammunition
 - f. Other loose equipment
4. Intentional destruction of downed aircraft will be considered only if capture of the aircraft with weapons mounted intact appears imminent. Every attempt will be made to keep strike aircraft over the downed aircraft. The decision to intentionally destroy a downed aircraft will be made only by the Commanding Officer, 145th Aviation Battalion.
5. Search and Rescue will be provided with the necessary aircraft to transport the SAR and BOD people within III ARVN Corps.

F O R O F F I C I A L U S E O N L Y

6. The aircraft crew will use the following visual signals to inform other aircraft of their status:

- a. Red Smoke - In trouble - need med evac, rescue, cover.
- b. Green Smoke - No immediate problem.
- c. White Smoke - Receiving Fire - Thrown in direction of hostile fire.

7. Any operation that presents a high probability of encountering hostile ground fire will have in the task organization the following elements:

- a. Company maintenance aircraft with repair team.
- b. 56th Maintenance Co (DS) aircraft recovery team.

JOOST
Lt. Col

OFFICIAL:

Sauers
SAUERS
S-3

1 Incl:

Appendix 1 - Check List for Downed and/or Missing Aircraft

C-2
FOR OFFICIAL USE ONLY

167

II FFV _____ 56th Trans _____
12th Grp AAE _____
8-3 _____
Bn Safety Officer _____
Company _____

1. Source of Information _____
2. Date/Time Received _____
3. Date/Time of Incident/Accident _____
4. Location of Site (Coordinates) _____
5. Parent Unit of aircraft _____ Type/SN _____
6. Mission: OCS _____ CS _____ CA _____ MED EVAC _____ TRNG _____ OTHER _____
7. Circumstances: _____

8. Names of Crew P _____ CP _____
CE _____ G _____ OB _____

PASSENGERS: _____

9. Passengers/Troops Aboard: Yes _____ No _____ Number _____

10. Extent of Injuries P _____ CP _____

CE _____ G _____ OB _____

PASSENGERS: _____

11. Casualties _____ Commissioned _____ Warrant _____ EM _____

12. Status of Security of Site: Secured _____ Not Secured _____

13. Status of Weapons, Secured _____ Not Secured _____

14. Status of SOI/Radios, Secured _____ Not Secured _____

15. Damage to aircraft, None _____ Minor _____ Major _____ Total _____

16. Recovery in Process, Yes _____ No _____ Recovery Unit _____

17. Information received by _____ Aviation Officer _____

18. Remarks: **FOR OFFICIAL USE ONLY**

148

ANNEX "D" (ADMINISTRATION AND LOGISTICS) TO 145TH AVIATION
BATTALION SOP FOR AIRMOBILE OPERATIONS

1. General:

The Battalion S-4 is responsible for planning and providing the necessary logistical support for the Battalion during airmobile operations to include Class IIIA & V, medical and transportation.

2. Planning of Logistical Requirements:

a. Immediately upon notification of a pending airmobile operation, the Battalion S-4 will coordinate with the S-3 to determine:

- (1) Refueling location.
- (2) Number of aircraft participating in operation.
- (3) Flight time between refueling.
- (4) Time allotted for refueling.
- (5) Duration of operation.

b. Class IIIA:

- (1) Refueling operations at fixed installations:

(a) Unit JP/4 tankers - operational control of battalion S-4.

(b) Two 500 gallon fiber bladders loaded aboard 2½ ton trucks will be used to supplement JP/4 tankers capability as required.

- (2) Refueling operations at field locations:

(a) 2½ ton trucks loaded with 500 gallon bladders or 55 gallon drums will be used to refuel during an operation consisting of 2 flight elements or less.

(b) Rapid refueling method (portable pumps and 500 Gall bladders) will be utilized for Battalion size operations consisting of 2 or more flight elements.

c. Class V:

- (1) Refueling at fixed installation.

(a) Units will provide own ammunition for both armed helicopters and troop carriers.

FOR OFFICIAL USE ONLY

(b) Attached units will be provided ammunition resupply by unit designated by S-4

(2) Rearming at field locations

(a) Ammunition located at pre-stock points will be used by all units participating in the airmobile operation.

(b) S-4 will arrange for vehicles to transport ammunition to rearming site.

(3) S-4 will deliver or make arrangements for delivery of specific ammunition that is not available at the pre-stock points prior to start of operation.

e. Medical:

(1) Battalion flight surgeon will be located at battalion forward command post.

(2) Battalion Surgeon will arrange for an ambulance and medical aid men to be present at battalion forward command post (fixed installation).

(3) Medical evacuation plan will be determined by the battalion surgeon:

f. Transportation:

(1) S-4 will provide transportation as required.

(2) Units within the battalion will be directed to furnish vehicles to battalion S-4 to fulfill transportation requirements of command, staff and attached operating units.

3. Administration:

a. Crew chiefs will secure main rotor blades as soon as possible in order to expedite refueling.

b. Crew chiefs will refuel own aircraft at refueling sites.

c. Gunners will rearm own aircraft.

4. Reports:

a. S-4 will initiate para 4 of the after action report to S-3 upon completion of the airmobile operation.

b. Report will contain highlights of the operation in the following areas:

- (1) Supply
- (2) Maintenance
- (3) Medical
- (4) Administration

DISTR: Annex Z

JOGST
Lt Col

OFFICIAL:

Ganga Kumar
KOFAR
S-4

FOR OFFICIAL USE ONLY

170

ANNEX E: (COMMUNICATIONS) to 145th Aviation Battalion SOP for Airmobile Operations

1. PURPOSE: This SOP standardizes recurring communications support procedures within the 145th Aviation Battalion during airmobile operations except when modified by battalion order.

2. GENERAL

a. The 145th Aviation Battalion Communications SOP for airmobile operations is based on Command SOP's.

b. The battalion communications SOP contains instructions on organization, equipment, and routine operations of the battalion communications section.

c. These instructions include:

- (1) Radio Communications
- (2) Wire Communications
- (3) Messenger Service
- (4) Radio Relay Communications
- (5) Visual Communications
- (6) Stagefield Organization and Procedures

3. RADIO COMMUNICATIONS

a. The Battalion Communications Officer will supervise the frequency and call sign assignments provided by higher headquarters.

b. Jamming and interference reports will be submitted to the battalion signal officer without delay, giving time, frequency, type of jamming (interference), signal strength, readability, and identification of interfering station.

c. The battalion communications section will establish FM and UHF Radio Net Control Stations at the battalion rear CP, battalion forward CP, and at the battalion alternate CP during all combat airmobile operations and during battalion directed company operations.

d. Battalion radio nets will conform to those prescribed in the current signal annex to the airmobile operations order.

e. Radio communications on battalion command nets during airmobile operations will be limited to operational reports and emergencies.

FOR OFFICIAL USE ONLY

f. Brevity of transmission will be stressed in all cases.

g. Brevity codes will be utilized as outlined in the signal annex and Battalion SOI.

4. WIRE COMMUNICATIONS

a. The battalion communications section will maintain and operate a switchboard at the 145th Aviation Battalion rear CP.

b. The battalion communications section will maintain and operate a switchboard at forward command post or staging area when the battalion is in the field for extended periods of time.

c. Wire lines will normally be installed to battalion units during field operations and will be maintained by the battalion communications section.

d. Battalion units will provide field telephones for termination of lines to the battalion switchboard.

5. MESSENGER SERVICE

a. The battalion communications section will provide messenger service as required.

b. Service that may be required:

(1) Delivery of SOI's.

(2) Pick up and delivery of messages, orders, and reports.

c. Frequency of delivery and pick up will be determined by the battalion adjutant and signal officer as required by the tactical situation.

6. RADIO RELAY COMMUNICATIONS

a. Radio relay communications on battalion command nets will be provided during airmobile operations by O1-F aircraft of the 74th Aviation Company.

b. High frequency (SSB) ground relay stations will be maintained at the battalion rear and battalion forward CP's.

7. VISUAL COMMUNICATIONS

a. Battalion subordinate units aircraft will be distinctively marked for ease of identification during airmobile operations as follows:

UNIT

MARKING

(1) 68th Aviation Company

Dayglo and Red

(2) 118th Aviation Company

Dayglo and Green

FOR OFFICIAL USE ONLY

2 172

- (3) 197th Aviation Company Dayglo and White
(4) A/501st Aviation Company Dayglo and Blue

b. Sacks will be employed during operations by color as indicated:

<u>COLOR</u>	<u>ACTION or INDICATION</u>
(1) Yellow	Marks LZ
(2) Red	Emergency, downed aircraft, need medical evacuation
(3) White	Marks enemy or enemy fire
(4) Green	No immediate problem

8. STAGE FIELD ORGANIZATION AND PROCEDURES

a. Communications equipment utilized during staging operations varies with the distance of the objective area from the stage field, the accessibility of the staging area to vehicles, and the availability of transportation for movement of communications equipment to isolated stage fields. The following equipment is needed for normal operations:

- (1) FM Radio - 1 AN/PRC-25 or AN/GRC-125
- (2) UHF Radio - 1 VRC-24
- (3) 1 - RC 292 + Mast with Mounted UHF Antenna
- (4) 1 - Field Table
- (5) 2 - Chairs (folding)
- (6) Pathfinder FM Control Radios, 2 - AN/PRC-25's w/batteries
- (7) 1.5 kwDC Generator
- (8) 1 - Shop Van or 1 - Tent (fly)

b. Communications equipment required at the forward command post:

- (1) FM Radio - 2 AN/PRC-25's w/batteries
- (2) UHF Radio - 1 VRC-24
- (3) 1.5 kw DC Generator

c. Personnel required for stagefield control

- (1) 3 Radio Operators
- (2) 1 Operations NCO or Communications Sergeant

FOR OFFICIAL USE ONLY

173

- (3) 2 Wiremen (on extended operations)
- (4) 3 Switchboard Operators (on extended operations)
- (5) 2 Radio Operators - will be required at advance CP

d. The signal officer will have available additional operations codes, authentication tables, and SOI extracts, and will be thoroughly familiar with their use.

e. Staging area communications equipment will be set up and checked early enough to allow replacement or repair of equipment before the operations begins.

f. The signal officer will normally be located at the forward CP during airborne operations.

9. SIGNAL SECURITY

a. Transmission security will be monitored and controlled by the NCS.

b. All classified documents will be secured in an authorized container when not in use.

c. All SOI's carried on aircraft will be secured on the person of the aviator to prevent inadvertent loss in flight.

d. The compromise of any codes or SOI's will be reported as soon as possible to the battalion S-2.

e. Documents may be destroyed to prevent capture. A report will be submitted to the battalion signal officer giving time, place, and method of destruction.

f. Classified documents will not be left unattended.

JOOST
Lt Col

DISTR: Annex Z

OFFICIAL:

Sauers
SAUERS
S-3

F O R O F F I C I A L U S E O N L Y

E-4

174

APPENDIX 1 (COMMAND NET UHF) TO: Annex E (COMMUNICATIONS) TO: 145th Aviation Battalion SOP for Airmobile Operations

1. General:

a. The purpose of the battalion UHF net is to provide any member of the battalion away from the Headquarters in an aircraft a means of contacting any portion of the battalion headquarters.

b. The battalion UHF net will operate on the primary battalion UHF frequency and will be monitored 24 hours a day.

2. Diagram:

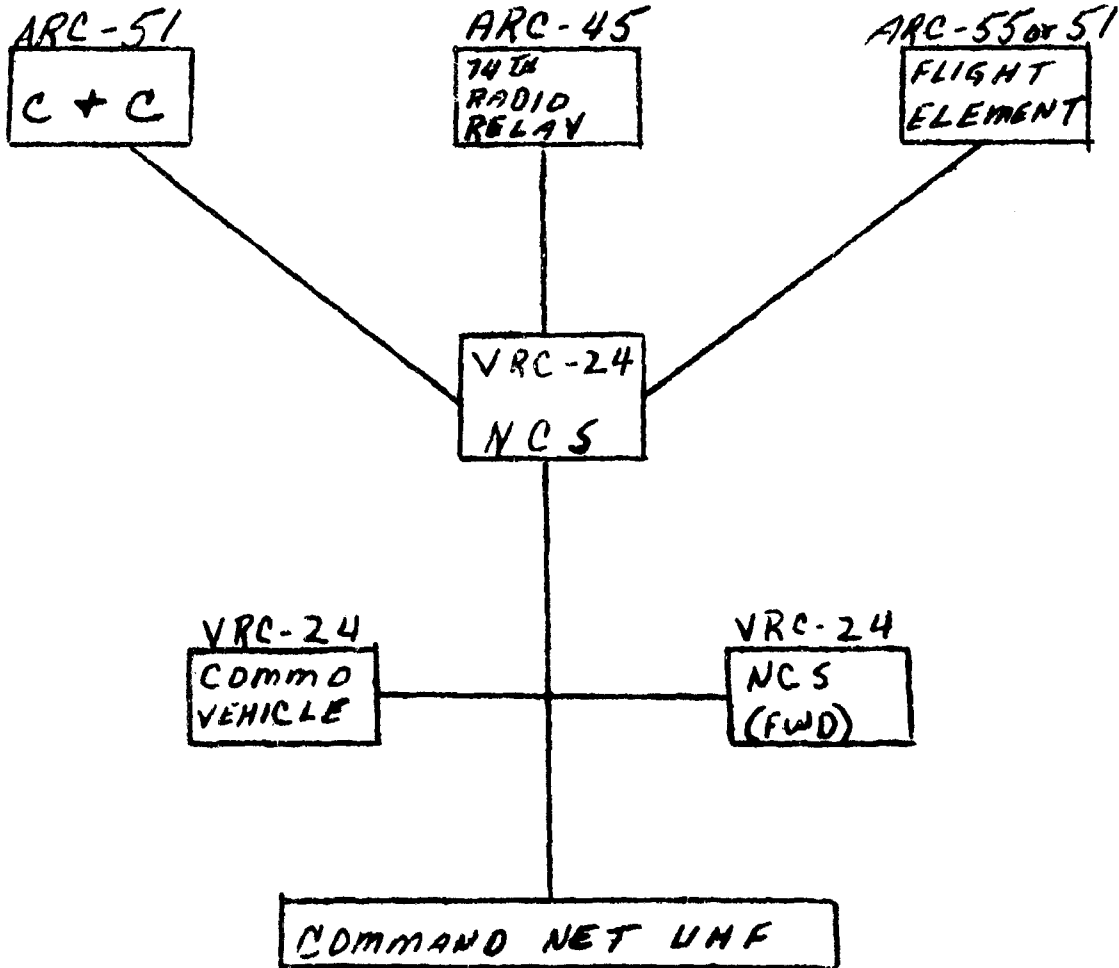

FOR OFFICIAL USE ONLY

APPENDIX 2 (COMMAND NET FM) TO: Annex E (COMMUNICATIONS) TO: 145th Aviation Battalion SOP for Airmobile Operations

1. General:

a. The purpose of the battalion FM net is to provide any member of the battalion away from the Headquarters in a ground vehicle or aircraft, a means of contacting any portion of the Battalion Headquarters.

b. The battalion FM net will operate on the primary command frequency and will be monitored 24 hours a day.

2. Diagram:

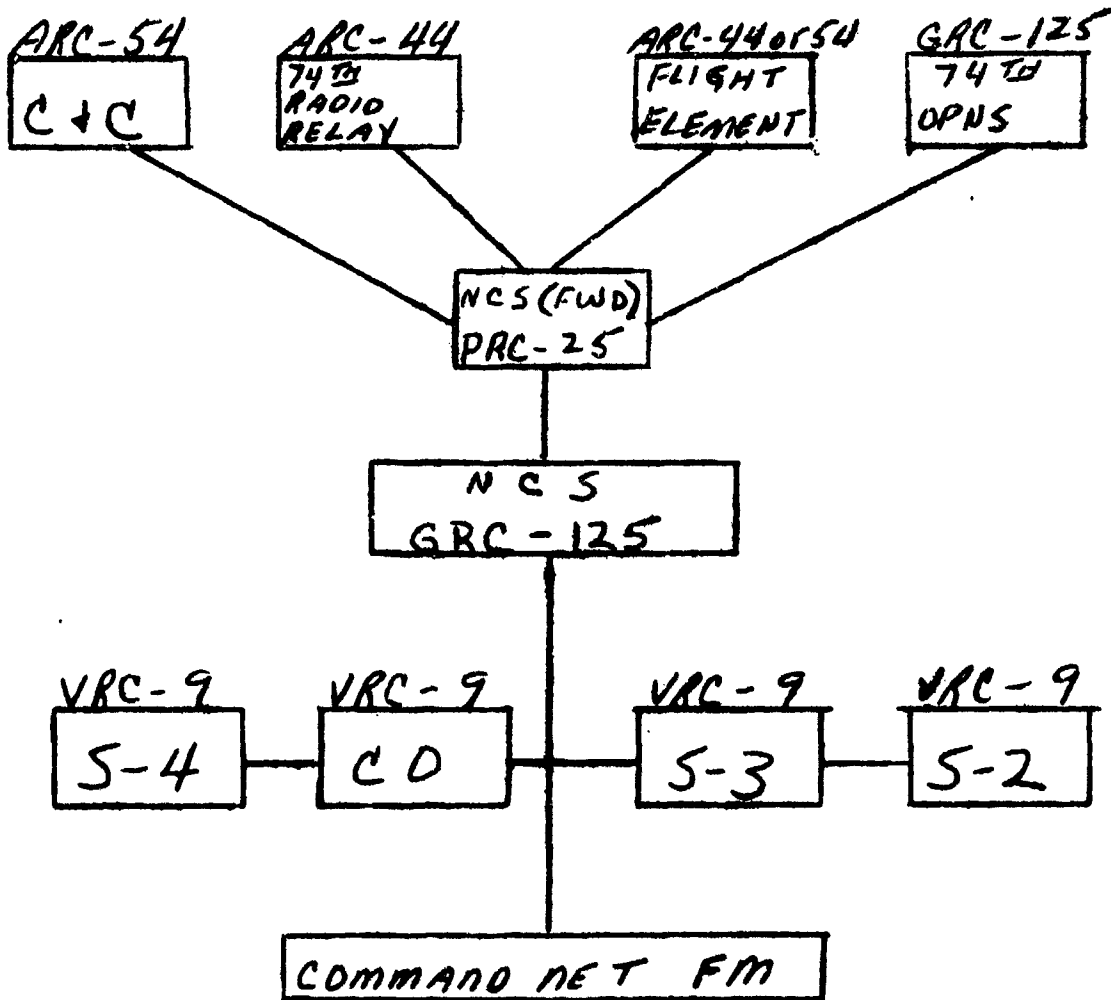

FOR OFFICIAL USE ONLY

APPENDIX 3 (12TH AVIATION GROUP NET FM WITH BACKUP SSB NET) To: Annex E (COMMUNICATIONS) TO: 145th Aviation Battalion SOP for Airmobile Operations

1. General:

a. The purpose of the 12th Aviation Group FM Net is to provide the Group Commander with a command net with which he can contact each battalion within the 12th Aviation Group.

b. The Group FM Net is backed up by an on call Group SSB Net.

c. The 145th Aviation Battalion has been directed by 12th Aviation Group to operate a station in the Group FM Net and to act as alternate net control station.

d. The 145th Aviation Battalion functions in the Group SSB Net as it does in the Group FM Net.

e. The battalion FM station will operate on the 12th Aviation Group primary FM frequency and will monitor traffic from 0730 to 1800 hours daily Monday through Saturday.

f. The battalion SSB station will operate on the 12th Aviation Group primary single side band frequency as directed by 12th Aviation Group.

2. Diagram:

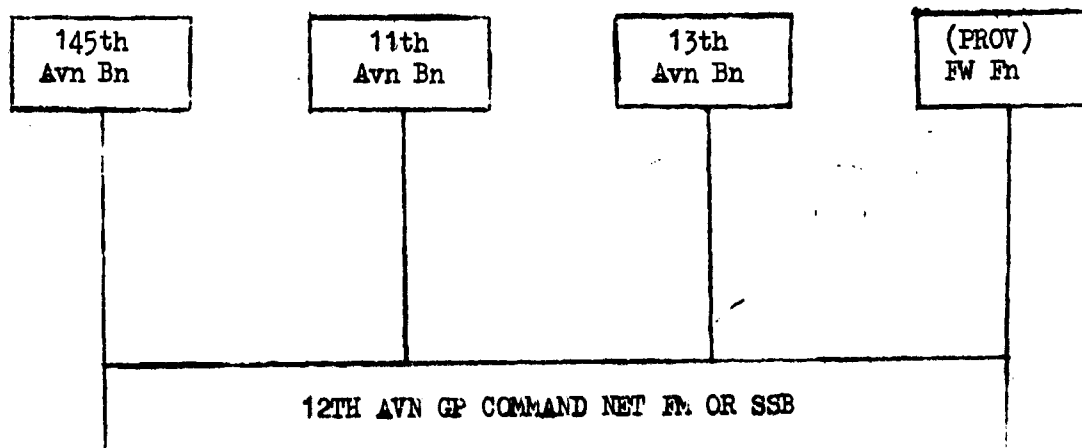

FOR OFFICIAL USE ONLY

Annex F (Helicopter Formations) to 145th Aviation Battalion SOP for
Airmobile Operations.

1. PURPOSE

To establish standard helicopter formations to be utilized by units
of this command.

2. GENERAL

The attached illustrations of basic flight formations are established
as standard tactical formations which will be utilized by the 145th Aviation
Battalion and subordinate units during all combat operations.

3. Variations to the standard formations, as illustrated, may be employed
by the Air Mission Commander as necessary to adjust to the tactical
situation. Separation between helicopters, except in train will be a
minimum of 50 feet from the extremity of one helicopter to another.
In trail formation the separation between helicopter extremities will be
a minimum of 100 feet. The basic helicopter formations used by the 145th
Aviation Battalion are as follows:

- | | |
|--|---------------|
| a. Basic Symbols | (Appendix 1) |
| b. Echelon Left | (Appendix 2) |
| c. Echelon Right | (Appendix 3) |
| d. Basic "V" Flight Formation | (Appendix 4) |
| e. Heavy Left | (Appendix 5) |
| f. Heavy Right | (Appendix 6) |
| g. Company Trail | (Appendix 7) |
| h. Company Staggered Trail | (Appendix 8) |
| i. Company Column, Flights in V's of Three | (Appendix 9) |
| j. Company Diamond, Flight in V's of Three | (Appendix 10) |
| k. Company Echelon Left | (Appendix 11) |
| l. Company Echelon Right | (Appendix 12) |
| m. Company Column, Flights heavy left | (Appendix 13) |
| n. Company Column, Flights heavy right | (Appendix 14) |
| o. Battalion Vee Formation | (Appendix 15) |
| p. Battalion Column | (Appendix 16) |
| q. Battalion Echelon Left | (Appendix 17) |

17 Appendixes:

as

JOOST
Lt Col

OFFICIAL:

Jones
S-3
S-3

Appendix 1 (Basic Symbols) to Annex F (Helicopter Formations) to
145th Avn Bn SOP for Airmobile Ops.

BASIC SYMBOLS

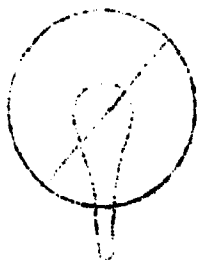

Troop Carrier

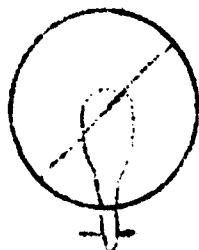

Section Leader

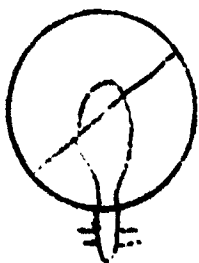

Mission Commander

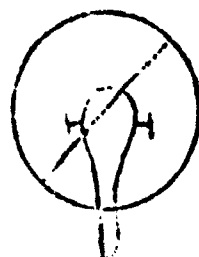

Armed Ship

ECHELON LEFT

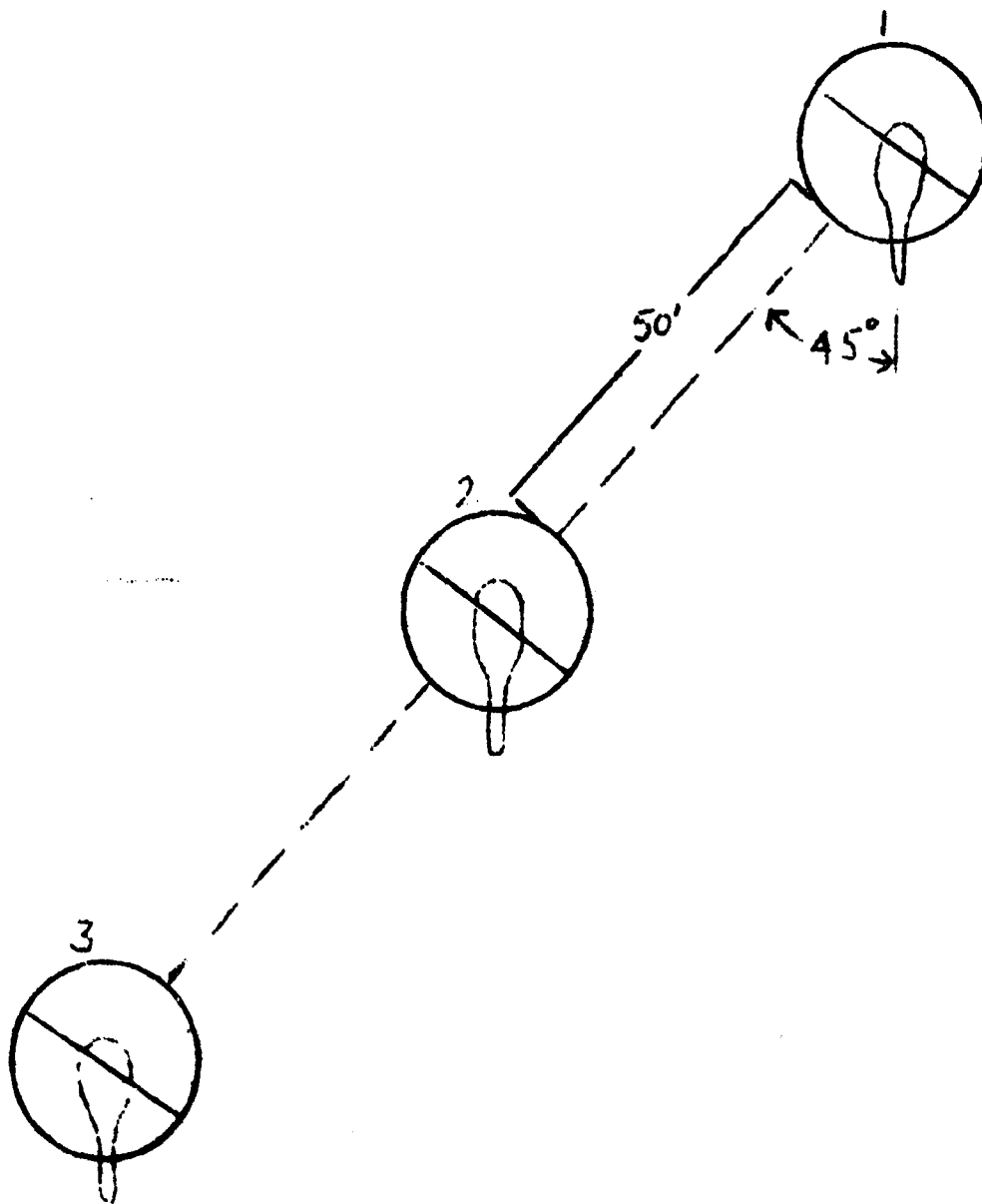

SAUERS
9-3

190
FOR OFFICIAL USE ONLY

ECHOLON RIGHT

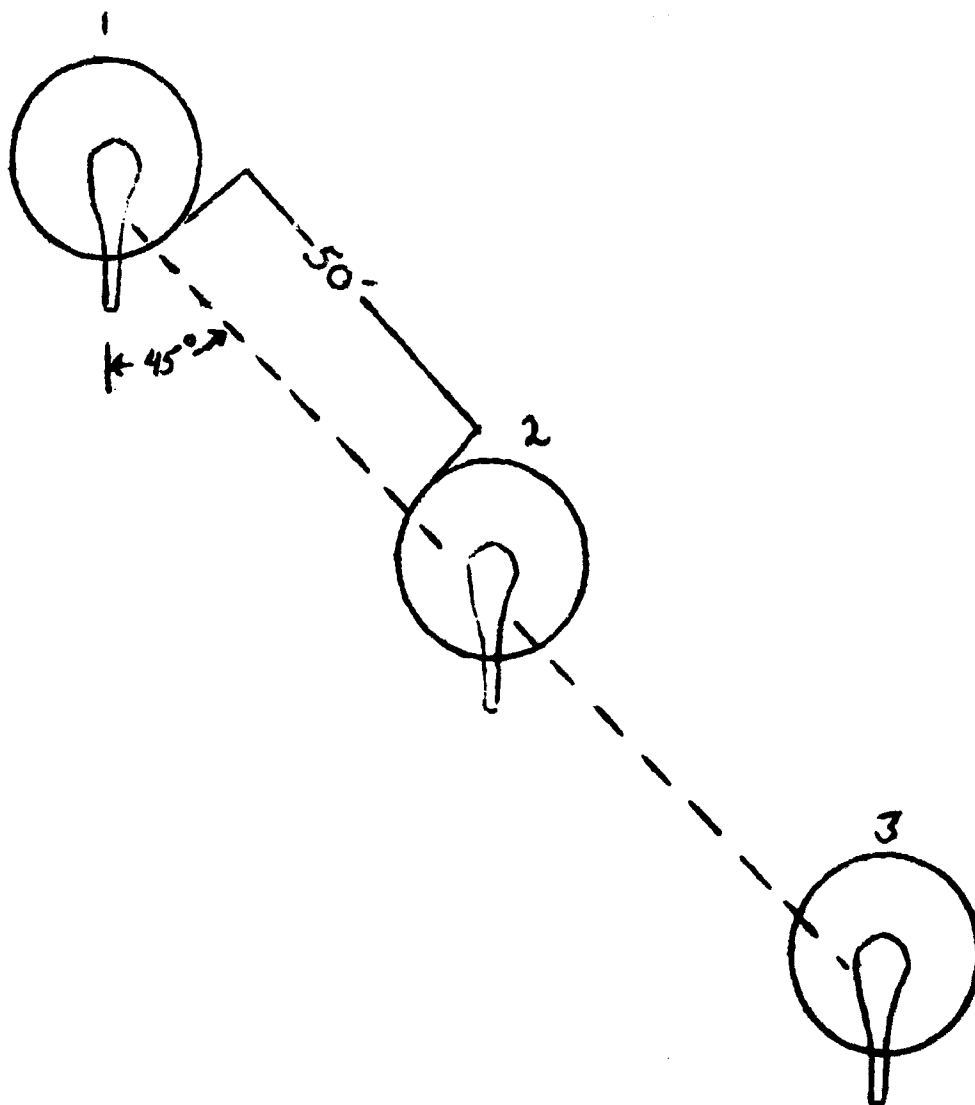

SAUERS
S-3

181

FOR OFFICIAL USE ONLY

Appendix 4 (Basic "V" Flight Formation) to Annex F (Helicopter Formations)
to 145th Avn Bn SOP for Airmobile Opns.

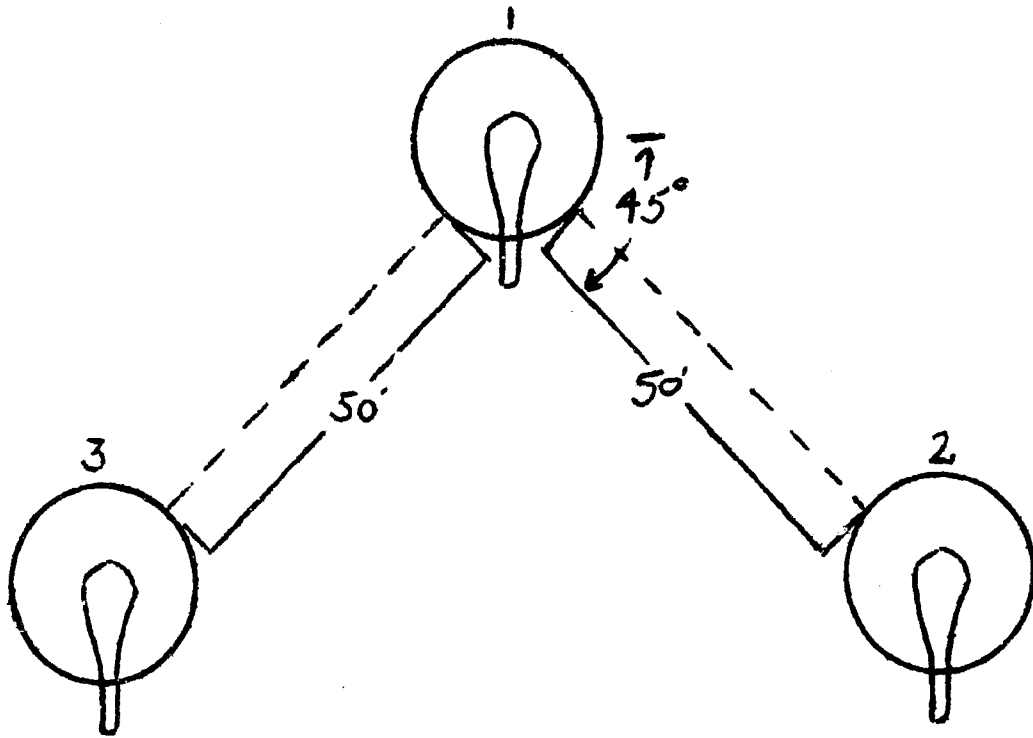

SAUERS
S-3

182

FOR OFFICIAL USE ONLY

BASIC HEAVY LEFT FORMATION

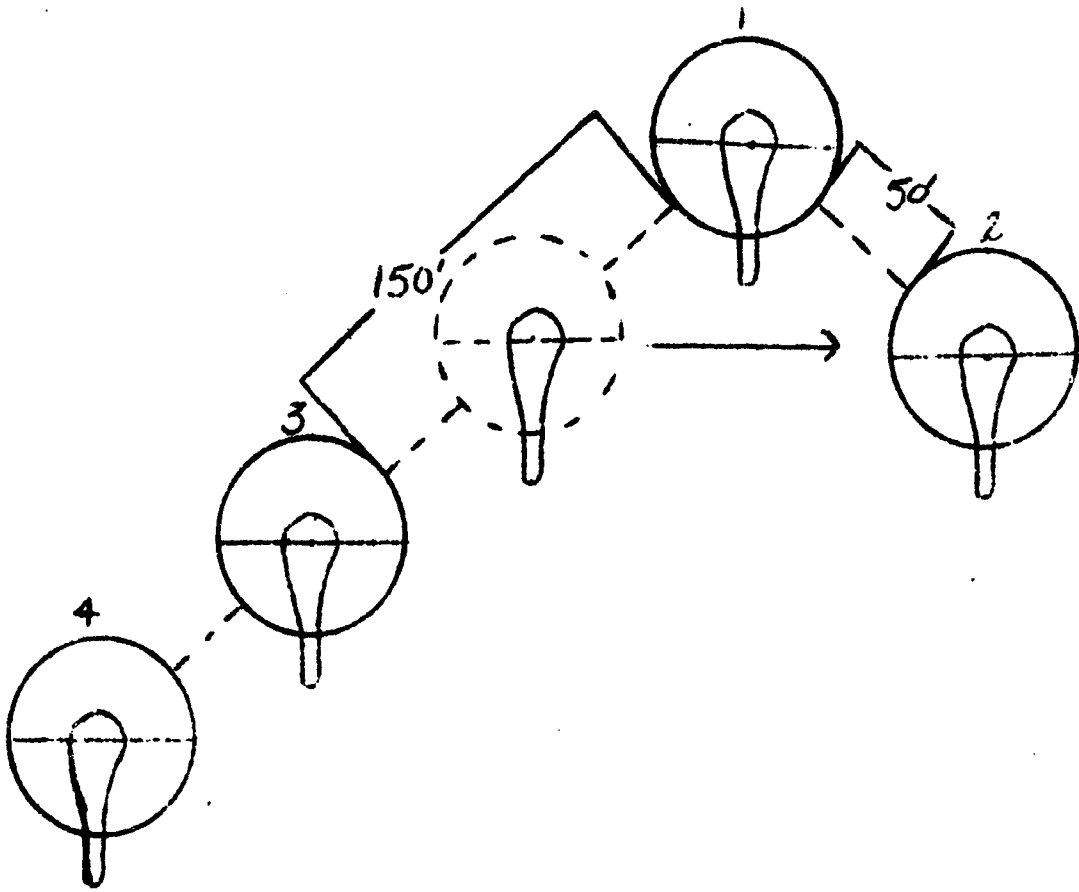

BASIC HEAVY RIGHT FORMATION

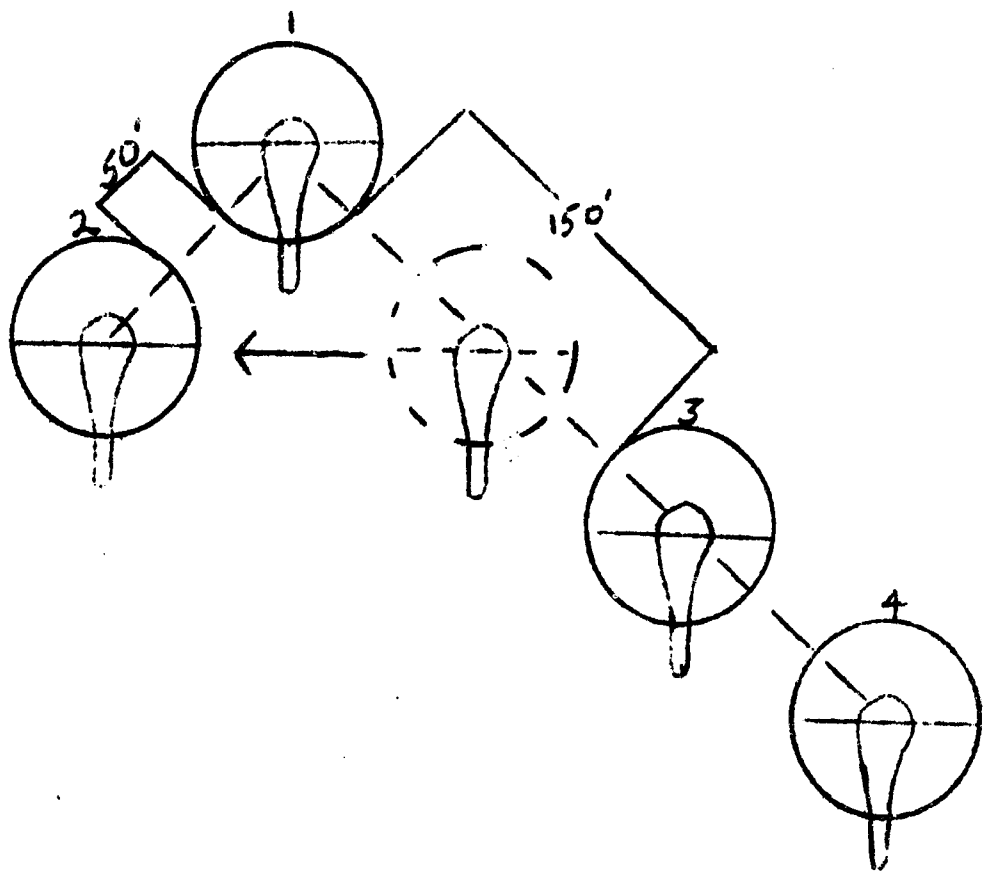

SAUERS
S-3

184

FOR OFFICIAL USE ONLY

145th Avn Bn SOP for Airmobile Opns.
COMPANY TRAIL

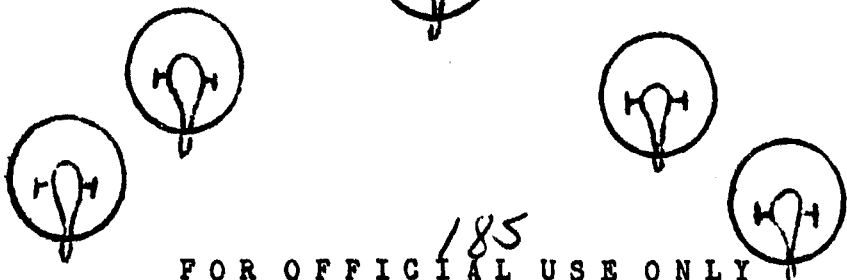
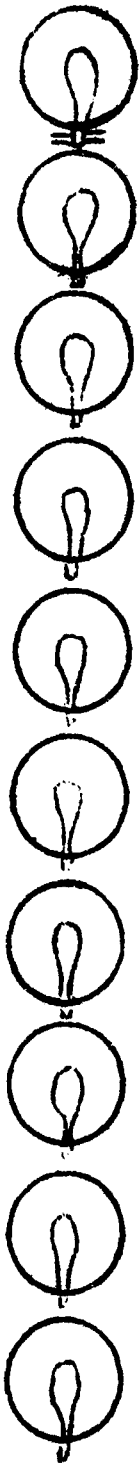

SAUERS
S-3

185
FOR OFFICIAL USE ONLY

COMPANY STAGGERED TRAIL (RIGHT)

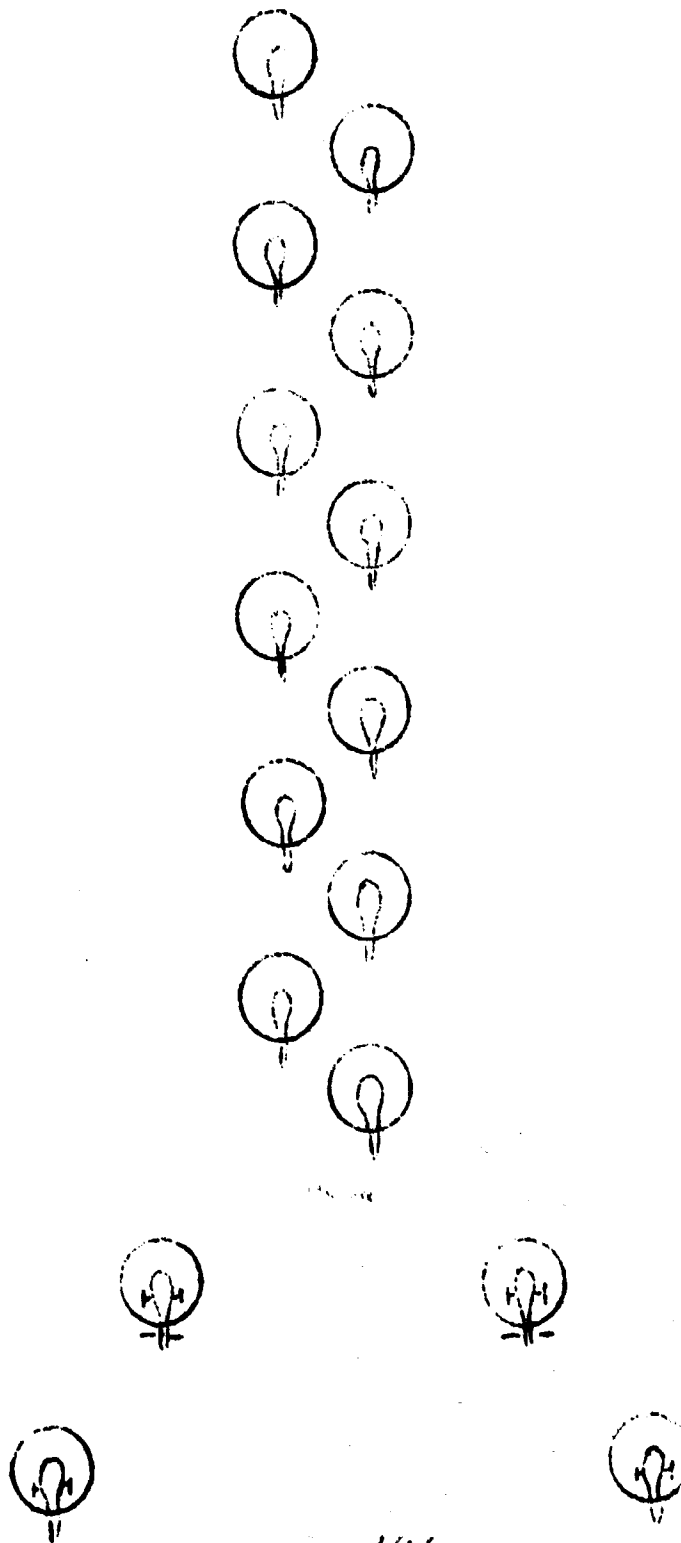

SAUERS
S-3

186

FOR OFFICIAL USE ONLY

COMPANY COLUMN FLIGHTS IN VEE'S OF THREE

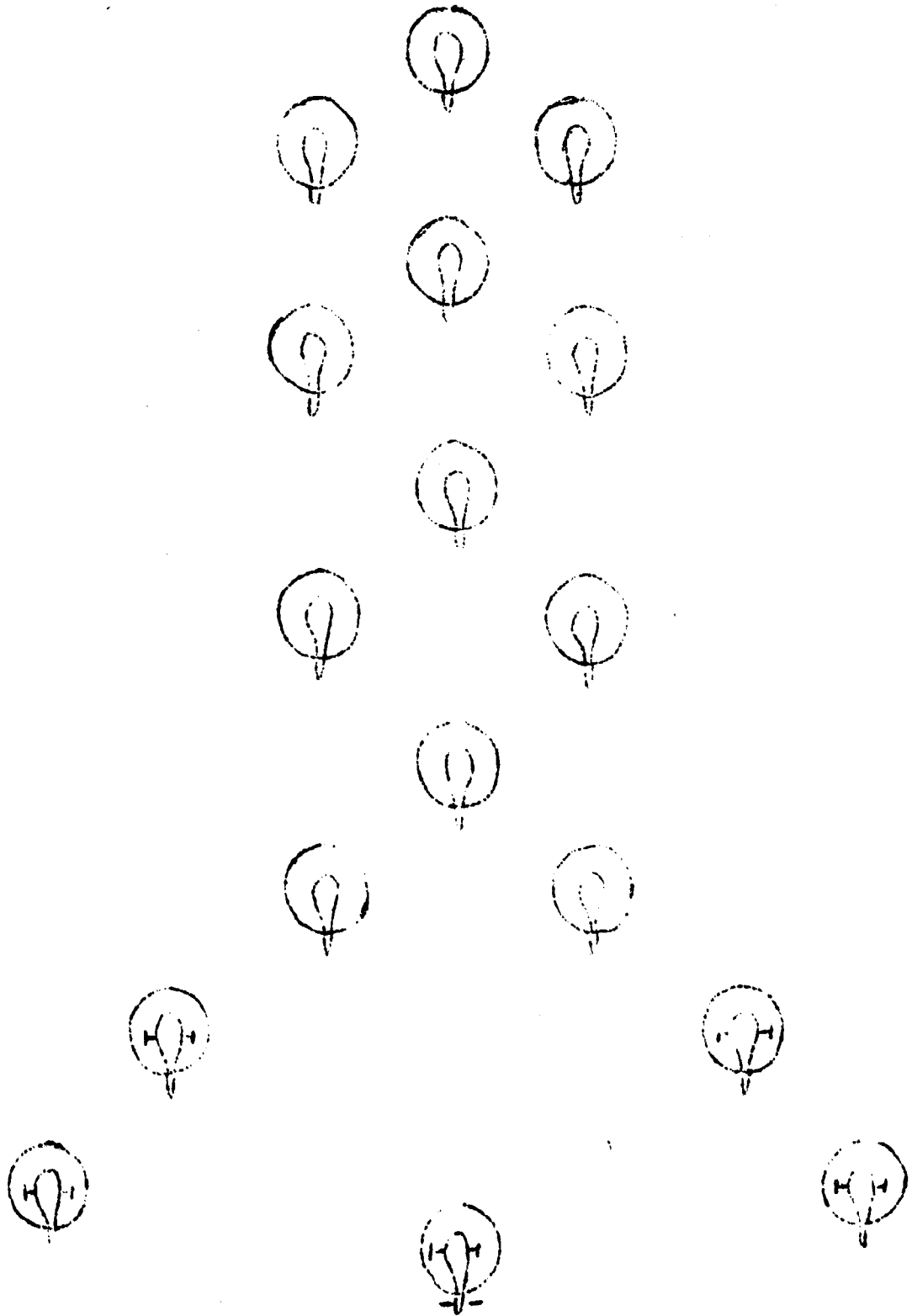

SAUERS
S-3

187
FOR OFFICIAL USE ONLY

Company Diamond, Flight in V's of Three) to Annex F
(Helicopter Formations) to 145th Avn Bn SOP for Airmobile Opns.
COMPANY DIAMOND FORMATION FLIGHTS OF V's OF THREE

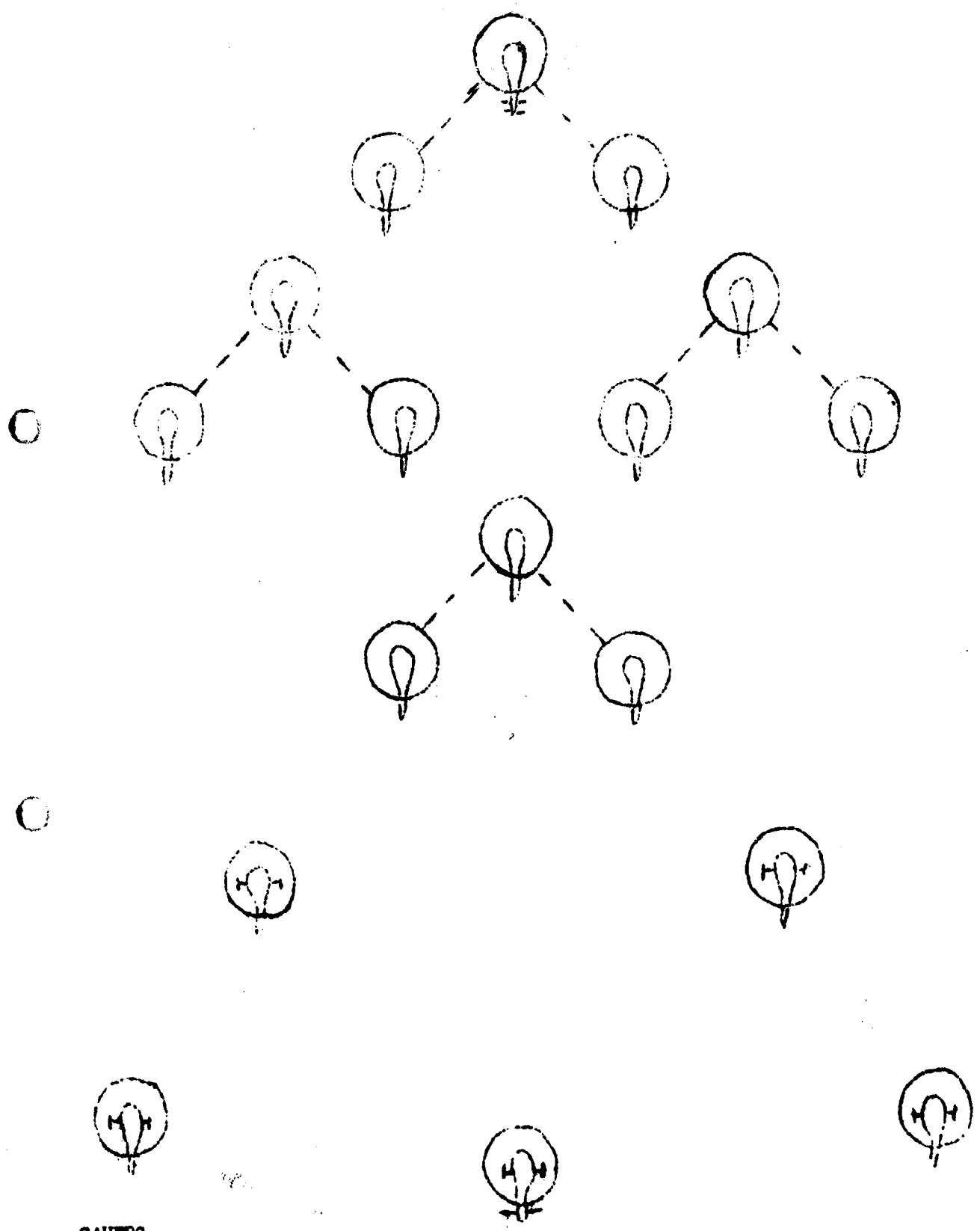

SAUERS
S-3

FOR OFFICIAL USE ONLY

188

COMPANY ECHELON LEFT

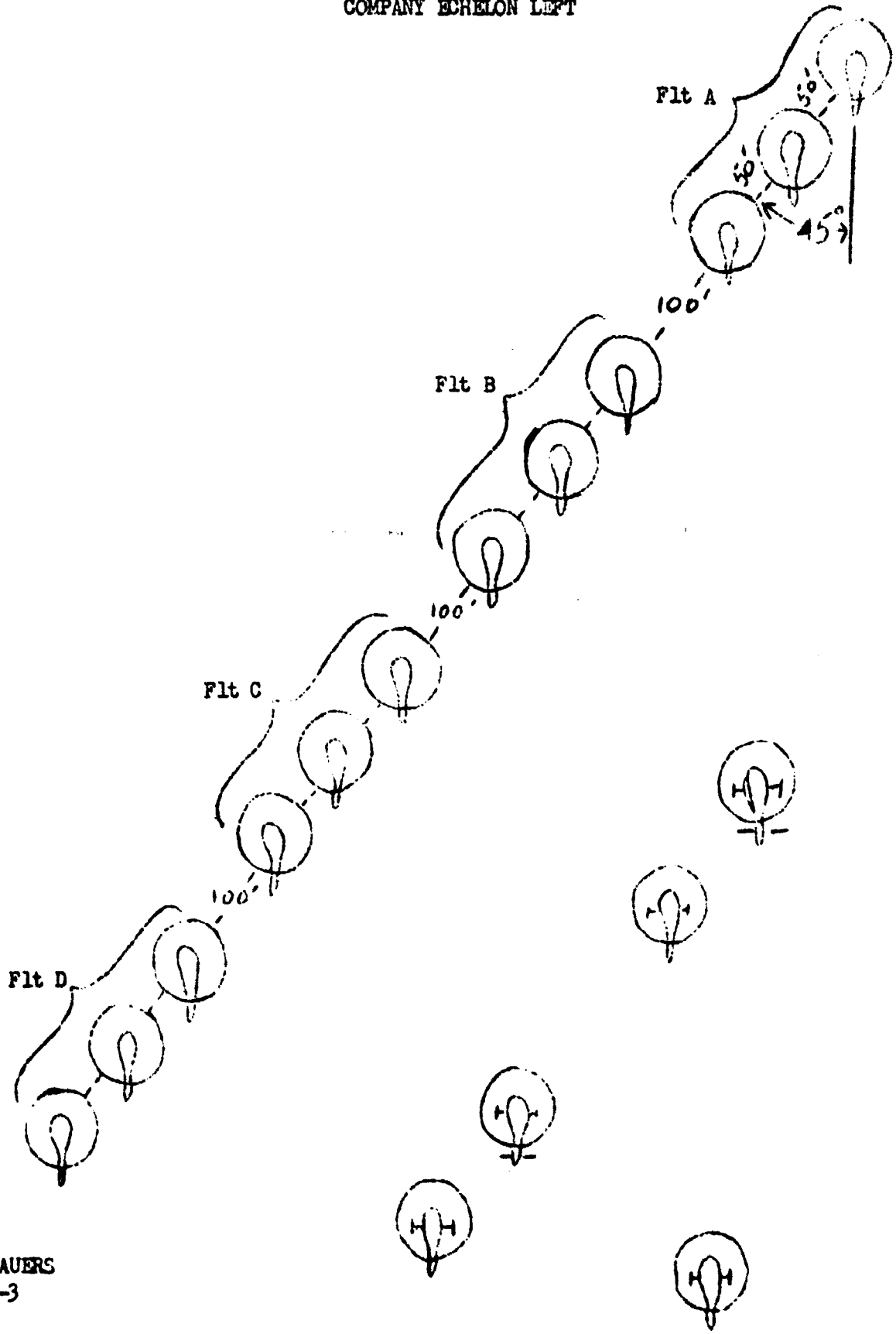

SAUERS
S-3

FOR OFFICIAL USE ONLY

189

COMPANY ECHELON RIGHT

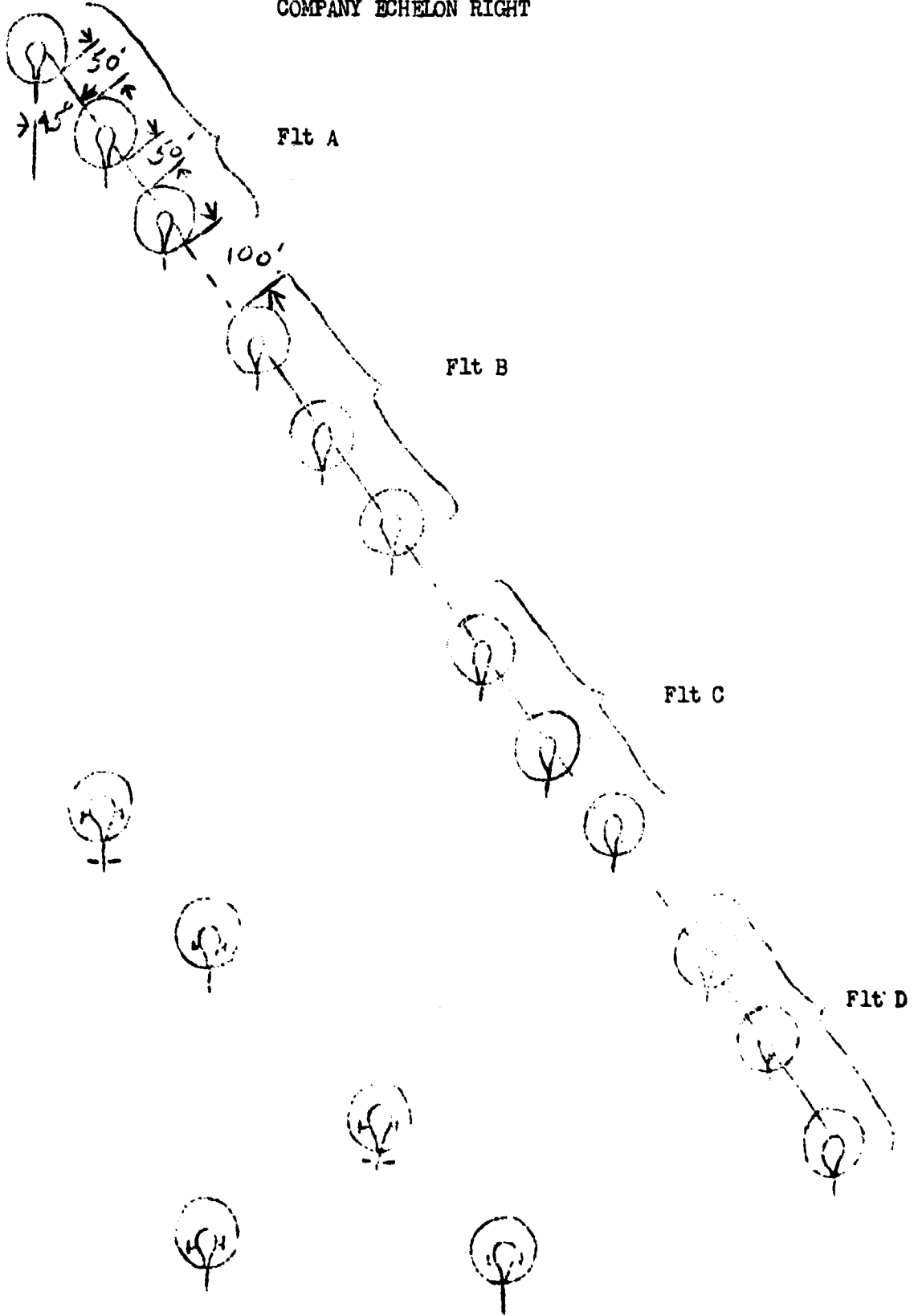

SAUERS
S-3

FOR OFFICIAL USE ONLY

190

COMPANY Column of four HEAVY LEFT

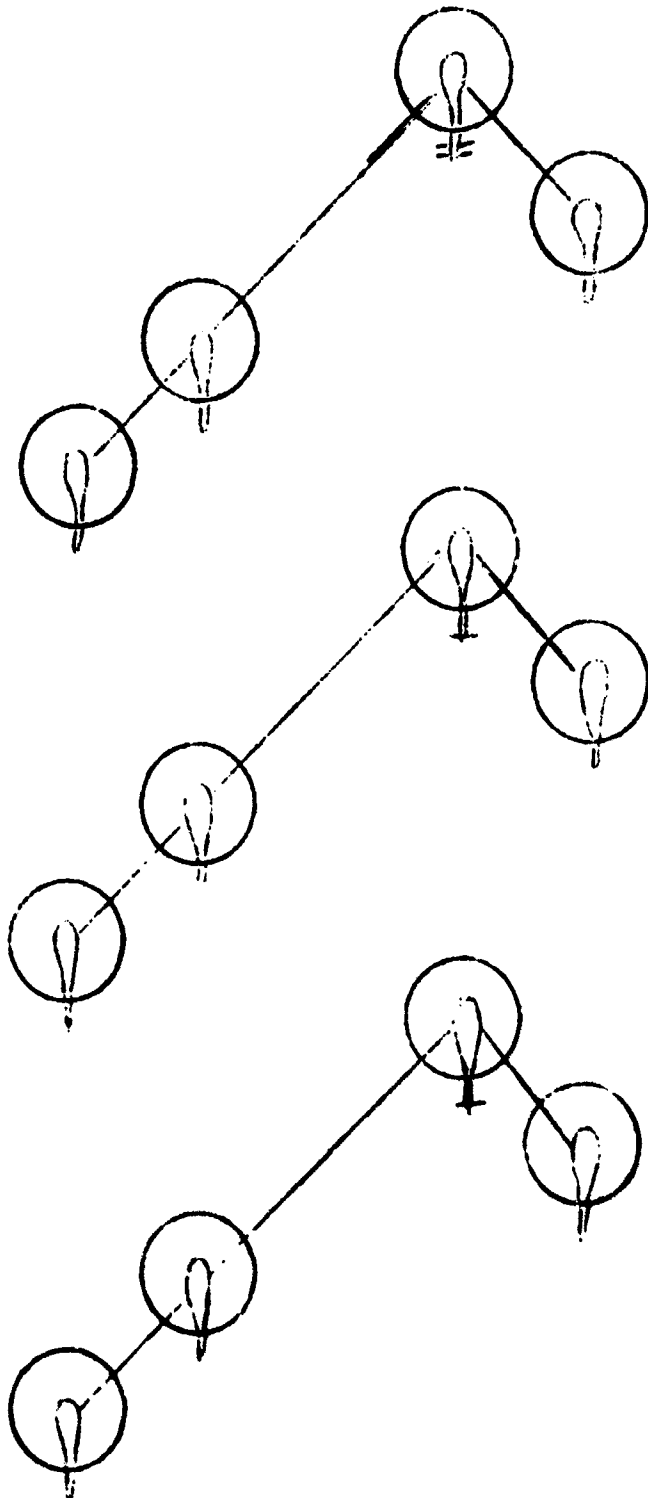

SAUERS
S-3

FOR OFFICIAL USE ONLY

191

Flt A

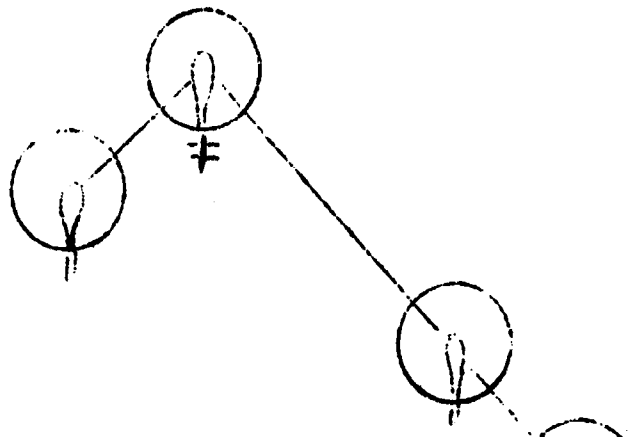

Flt B

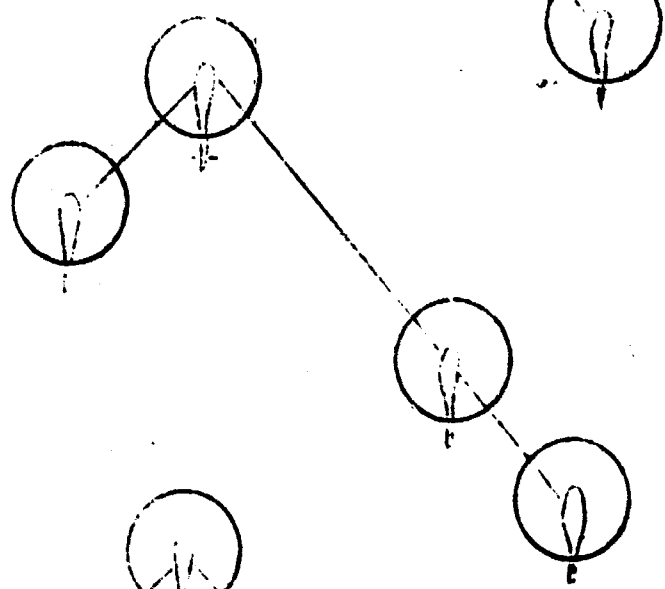

Flt C

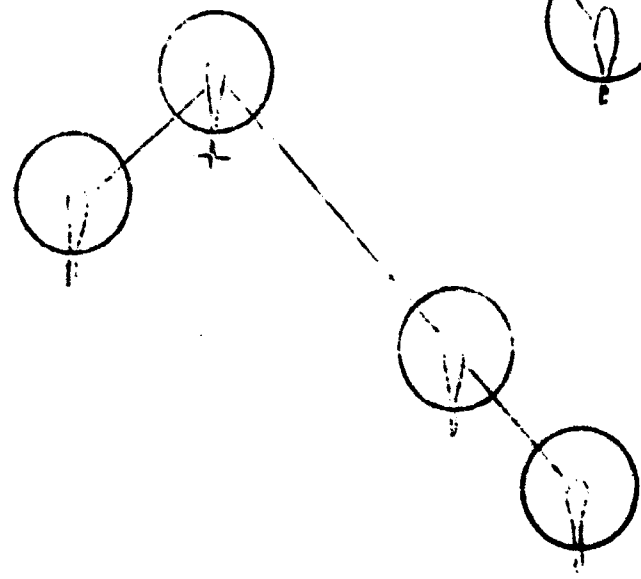

SAUERS
S-3

BATTALION VEE FORMATION

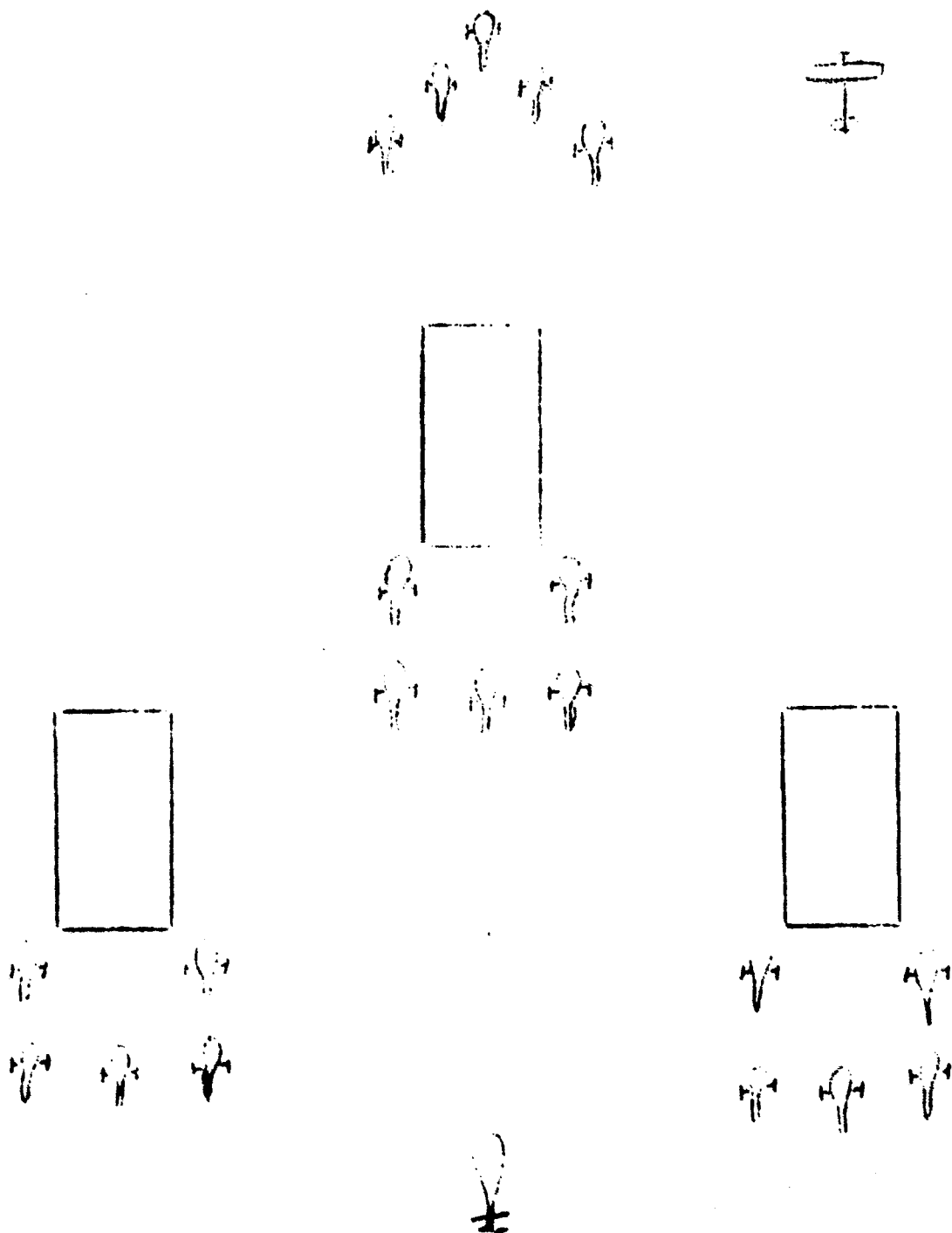

CFC

SAUERS
S-3

FOR OFFICIAL USE ONLY

Appendix 16 (Battalion Column) to Annex F (Helicopter Formations) :
145th Avn Bn SOP for Airmobile Opns

BATTALION COLUMN

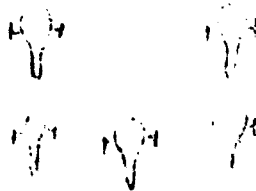
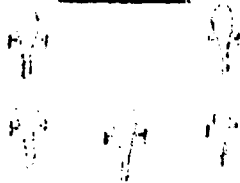
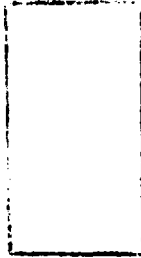

CPC
HE

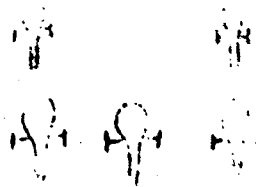

SAUFERS
S-3

FOR OFFICIAL USE ONLY

BATTALION ECHELON LEFT

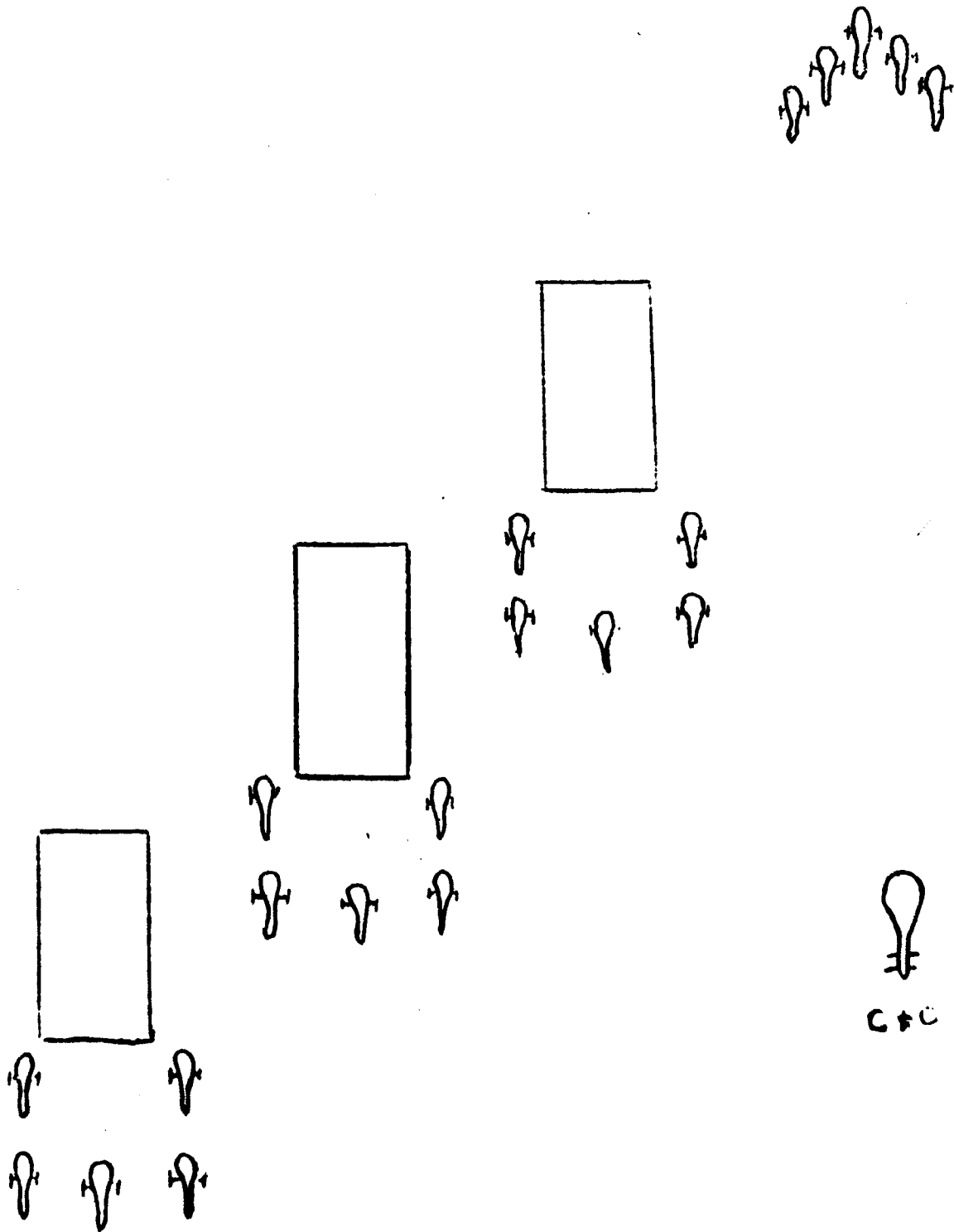

SAUERS
8-3

FOR OFFICIAL USE ONLY

195

Hqs, 145th Avn Bn
Bien Hoa, RVN
15 April 1966

Annex G (Flight Route Corridor) to 145th Aviation Battalion SOP for
Airmobile Operations.

1. PURPOSE: To establish procedures to be followed by all elements of this command to minimize the hazard to aircraft from friendly artillery.

2. SCOPE: With the introduction of US Army ground elements and supporting artillery in the Republic of South Vietnam, free or uncontrolled flight cannot be conducted safely. The density of US artillery positions in III ARVN Corps dictates the establishment of an airway system. To achieve this objective, flight corridors and controlling agencies have been established. All projected flight corridors are routed to and from major military installations. The flight corridors established will provide airspace free from US artillery only. If the flight path to be flown, whether within or outside of an established corridor, is over or near an ARVN artillery location, communications must be made with that installation for artillery advisory. The flight corridors Do Not guarantee freedom from ARVN artillery. The air-ground radio frequencies listed in the current SOI must be used to clear your route of flight over or in close proximity to all ARVN artillery units.

a. Flight corridor dimensions:

(1) All flight corridors are 4000 meters wide (2000 meters each side of a center line) and follow prominent terrain features for ease of identification.

(2) All flights will be free of artillery between the ground and 3000 feet (M); however, since all flight corridors pass directly over all of the friendly artillery in III Corps it is necessary to restrict the width and altitude of corridors at these locations. Width will be limited to 2000 meters and altitude must be between 2500 and 3000 feet.

b. Flight Corridor Agencies: To provide for the safe and expeditious flow of air traffic and create a central control element for all friendly artillery, two Artillery Air Control Center (AACC) have been established.

(1) 1st. (US) Infantry Division AACC

(a) All air traffic within the specified corridors east of the Saigon River (on a line from southeast to northwest) will monitor the designated frequency of the 1st. (US) Infantry Division AACC.

(b) US artillery units under the jurisdiction of the 1st (US) Infantry Division are located at Phouc Vinh, Lai Khe, Phu Loi, Dien, Bien Hoc and Xuan Loc.

(2) 25th (US) Infantry Division AACC

FOR OFFICIAL USE ONLY

196

(a) All air traffic within the specified corridors west of the Saigon River will monitor the designated frequency of the 25th (US) Infantry Division AACC.

(b) US artillery units under the jurisdiction of the 25th (US) Infantry Division are located at Cu Chi.

c. Flight Corridor Procedures:

(1) Daylight hours (0700-1900): All aircraft on single aircraft missions are guaranteed friendly artillery clearance as long as their flight path remains well within the flight corridor. Aviators utilizing the assigned corridors will at all times monitor the appropriate AACC frequency for warnings of non-scheduled artillery fires. Transmissions to the AACC agency are required only when requesting further artillery advisories, or departing a flight corridor. At the time of corridor departure the pilot must report the point of exit, destination, route of flight, altitude and time of exit to:

(a) The AACC having jurisdiction over that flight corridor.

(b) The artillery location whose fires cover the TAOR that is being overflown.

At that time pilots will be advised of any artillery fires which may effect their route of flight. Upon request from the aviator, fires will be suspended as directed by AACC, unless the lifting of fires is precluded by a tactical emergency.

(2) Hours of Darkness (1900-0700): Flight corridors during the hours of darkness are non-existent. At night, restrictions imposed on artillery by flight corridors are lifted. Aviators will obtain information of scheduled and non-scheduled fires affecting their flight path by monitoring the radio frequency of the AACC in who's area of responsibility the flight is being conducted. To obtain a desired flight path at night, prior coordination must be effected with the AACC agency directly involved.

(3) For company or battalion size airmobile operations the same procedure as above will be adhered to if existing corridors are suitable. Flight paths to be used to and from the established corridors will require advanced approval from the AACC having jurisdiction over the operational area to insure that timing of the operation is not disrupted while awaiting artillery clearance.

d. Artillery Grid System: The standard 1st (US) Infantry Division Artillery Grid System overlay will be utilized at all times when making reference to ~~artillery~~ positions, gun-target lines and flight path direction of movement. This grid system may also be used when calling fires on known or suspected enemy positions.

Appendix 1

Flight Route Corridor Diagram

ACKNOWLEDGE:

[Signature]
OFFICIAL

Sauer's S-3

JOOST
Lt Col

197

Appendix 1 (Flight Route Corridor Diagram) to Annex G to 145th Aviation
Battalion SOP for Airborne Operations

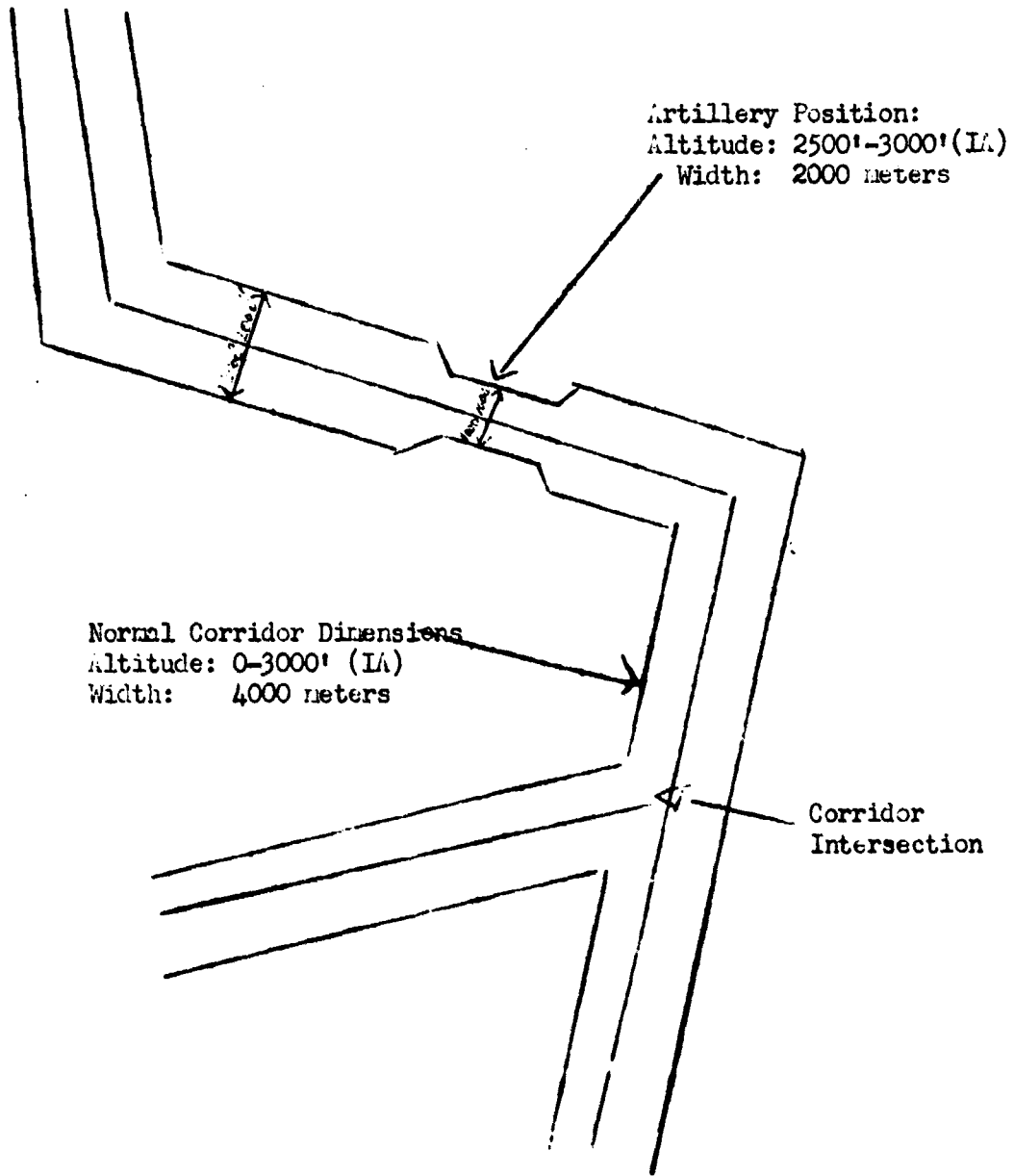

OFFICIAL:

SIGNERS:
S-3

Hqs, 145th Aviation Battalion
Bien Hoa, RVN
15 April 1966

Annex H (Command Post and Stagefield Organization and Procedures) to
145th Aviation Battalion SOP for Airmobile Operations.

1. PURPOSE: This SOP is to establish stagefield and command post procedures and organization for the Battalion Forward CP and Stagefield during airmobile operations, and applies ~~except~~ when modified by the commander.

2. GENERAL: The stagefield and command post, size, location, and required facilities will be determined during the planning phase of the operation. Size may vary from a single C&C aircraft to a full field Battalion CP organization.

3. ORGANIZATION:

a. The following staff groupings and support elements are normally utilized for Command Post organization and control:

- (1) Administration
- (2) Intelligence
- (3) Operations, Communications, and Stagefield Control
- (4) Logistics
 - (a) Aid Station
 - (b) POL and Armament
 - (c) Maintenance and Recovery

b. The Battalion Tactical Command Posts are normally organized as follows:

(1) Battalion Rear Command Post:

- (a) S-1 Section and Personnel
- (b) Intelligence NCO
- (c) Asst S-3
- (d) Asst S-4
- (e) Communications Section (-)
- (f) Safety Officer

(2) Battalion Forward Command Post:

- (a) Executive Officer
- (b) S-2
- (c) Asst S-3
- (d) OIC Pathfinder Detachment
- (e) Signal Officer
- (f) Chaplain
- (g) Flight Surgeon
- (h) HHD Commandant
- (i) S-4
- (j) Maintenance Officer

F O R O F F I C I A L U S E O N L Y

199

(3) Battalion Airborne Command Post (C&C Helicopter):

- (a) Commanding Officer
- (b) S-3
- (c) ALO
- (d) FSCC
- (e) Ground Commander

(4) Battalion Alternate Command Post

- (a) Operation NCO
- (b) Communications Personnel
- (c) Pathfinder Personnel
- (d) S-4 Sergeant

4. PERSONNEL, DUTIES, AND RESPONSIBILITIES:

a. The officer in charge of the CP will normally be the Battalion Executive Officer, or in his absence, be furnished by the S-3; he will have overall control and responsibility for the Command Post and Stagefield facilities, personnel, and operation.

b. The Stagefield Operations Officer or NCO will be furnished by the Battalion S-3; he will be responsible for all operational matters at the Command post and stagefield. His responsibilities include:

- (1) Maintain situation maps
- (2) Maintain aircraft availability status
- (3) Prepare estimates of aircraft operational readiness
- (4) Brief visiting personnel as required
- (5) Assume duties of stagefield commander in the absence of the executive officer.
- (6) Coordinate with Battalion S-4 for transportation of personnel and equipment.

c. The stagefield Intelligence Officer or NCO will be responsible for all intelligence matters pertinent to current operations. His responsibilities include the following.

- (1) Provide continuous military intelligence estimates of the enemy situation.
- (2) Make recommendations to the stagefield commander concerning.
 - (a) Flight Routes
 - (b) Landing zones
 - (c) Counterintelligence and deception plans
 - (d) EEI
- (3) Provide current weather and light data.
- (4) Maintain current enemy situation map.
- (5) Collect and consolidate information of the enemy from aviation units assigned or attached.
- (6) Disseminate intelligence information to assigned and attached units.

d. The stagefield Administrative Officer or NCO will be furnished by the Headquarters and Headquarters Commander. He will be responsible for:

F O R O F F I C I A L U S E O N L Y

200

- (1) Establishment of security, and the command post
- (2) Messing facilities for all staff and command personnel
- (3) Stagefield defense
- (4) Area police
- (5) Coordination of transportation requirements with Battalion S-4 for all equipment and personnel

e. The Battalion S-4 will be responsible for all logistical support. His responsibilities include:

- (1) Refueling of aircraft
- (2) Re-arming of aircraft
- (3) Coordination of POL and ammunition requirements at the stagefield
- (4) Coordination of Class I supply
- (5) Coordination of Transportation
- (6) Coordination of logistical requirement for continuing operations

f. The airfield parking and control officer or NCO will be furnished by Battalion S-3 (normally the Battalion Pathfinder); he will be responsible for stagefield parking, aircraft control, and troop loading. His responsibilities include:

- (1) Control of all inbound and outbound aircraft
- (2) Parking instructions to all aircraft (Appendix 2)
- (3) Organization and loading of troops
- (4) Lighting facilities necessary for control and parking of aircraft
- (5) Coordination with Battalion S-4 for transportation requirements

g. The Maintenance Officer or NCO will be furnished by the battalion maintenance section; he will be responsible for all recovery operations and maintenance of vehicles and aircraft as required. His responsibilities include:

- (1) Coordination of recovery operations when required
- (2) Liaison with recovery personnel
- (3) Monitoring overall maintenance status of aircraft
- (4) Coordination with Battalion S-4 for transportation requirements

h. The Medical Officer or NCO will be determined by the Battalion Flight Surgeon and will be responsible for stagefield and forward medical facilities. His responsibilities include:

- (1) Establishing an aid station at the stagefield
- (2) Coordination with other medical units (United States or Vietnamese) for facilities, equipment, and personnel
- (3) Coordination of transportation requirements for personnel and equipment to forward locations with S-4

i. The Communications Officer or NCO will be responsible for all communications at the stagefield and command post. His responsibilities include:

FOR OFFICIAL USE ONLY

201

- (1) Operation of ground to ground and ground to air communications from battalion to subordinate units (Annex E, Communications.)
- (2) Publication and distribution of SOI materials as required.
- (3) Coordination of transportation requirements with the Battalion S-4.

JOOST
Lt Col

Appendixes:

- 1-Command Post and Stagefield Equipment
- 2-Stagefield Arrangement and Aircraft Parking Diagram
- 3-Maintenance Recovery

Distribution Annex Z

OFFICIAL:

S. UERS
S. UERS:

S-3

Appendix I (Command Post and Stagefield Equipment) to Annex H (Command Post and Stagefield Organization and Procedures) to 145th Aviation Battalion SOP for Airmobile Operations.

1. PURPOSE: To outline the Battalion Command Post and stagefield minimum required items of equipment during combat operations.
2. GENERAL: The Headquarters Commandant is responsible for providing equipment, personnel and supervision for Command Post and stagefield operations:
3. EQUIPMENT: The following list of equipment is the minimum required for non-prolonged Command Post and stagefield operations:

a. Items of equipment common to both fixed facilities and field location CP.

- (1) Chairs, folding, steel, 22 ea
 - (2) Table, folding, wood, 6 ea
 - (3) Cot, folding, canvas, (as required)
 - (4) Air Mattress, (as required)
 - (5) Blanket, wool, (as required)
 - (6) Pillow, bed, ctn, tick (as required)
 - (7) Flash lights, 6 ea
 - (8) Candles, 4 doz
 - (9) Insect Repellant, 1 case
 - (10) Foot powder, 1 case
 - (11) Rations, (as required)
 - (12) Jug, insulated, 1 gal, 10 ea
 - (13) Bag, water, sterilizing, w/poles, 2 ea
 - (14) Can, water, military, 5 gal, 5 ea
 - (15) Lantern, gasoline, leaded fuel, 4 ea
 - (16) Shovel pick & axe, 6 ea
 - (17) CP signs
 - (18) Trunk, locker, wood, 4 ea
- (a) Cup, drinking, hot drink, 450 ea
 - (b) Salt tablets, w/dispenser, 1 ea
 - (c) Tape, cloth, 4" Green, 1 ea
 - (d) Engineer Tape, 1 roll
 - (e) Malaria pills

b. Additional equipment required for field location CP...

- (1) Tent, command post, w/poles, 1 ea
- (2) Tent, general purpose, w/poles, (as required)
- (3) Table, wood, 4 ea
- (4) Concertina wire, (as required)
- (5) Sandbags (as required)
- (6) Generator 3 KW
- (7) Light set (25 outlet)
- (8) Field Phones TA 312, 8 ea

OFFICIAL:

SAUERS
S-3

203

Appendix 2 (Stagefield Arrangement & Aircraft Parking Diagram) to Annex H
(Command Post and Stagefield Organization and Procedures) to 145th Aviation
Battalion SOP for Airmobile Operations

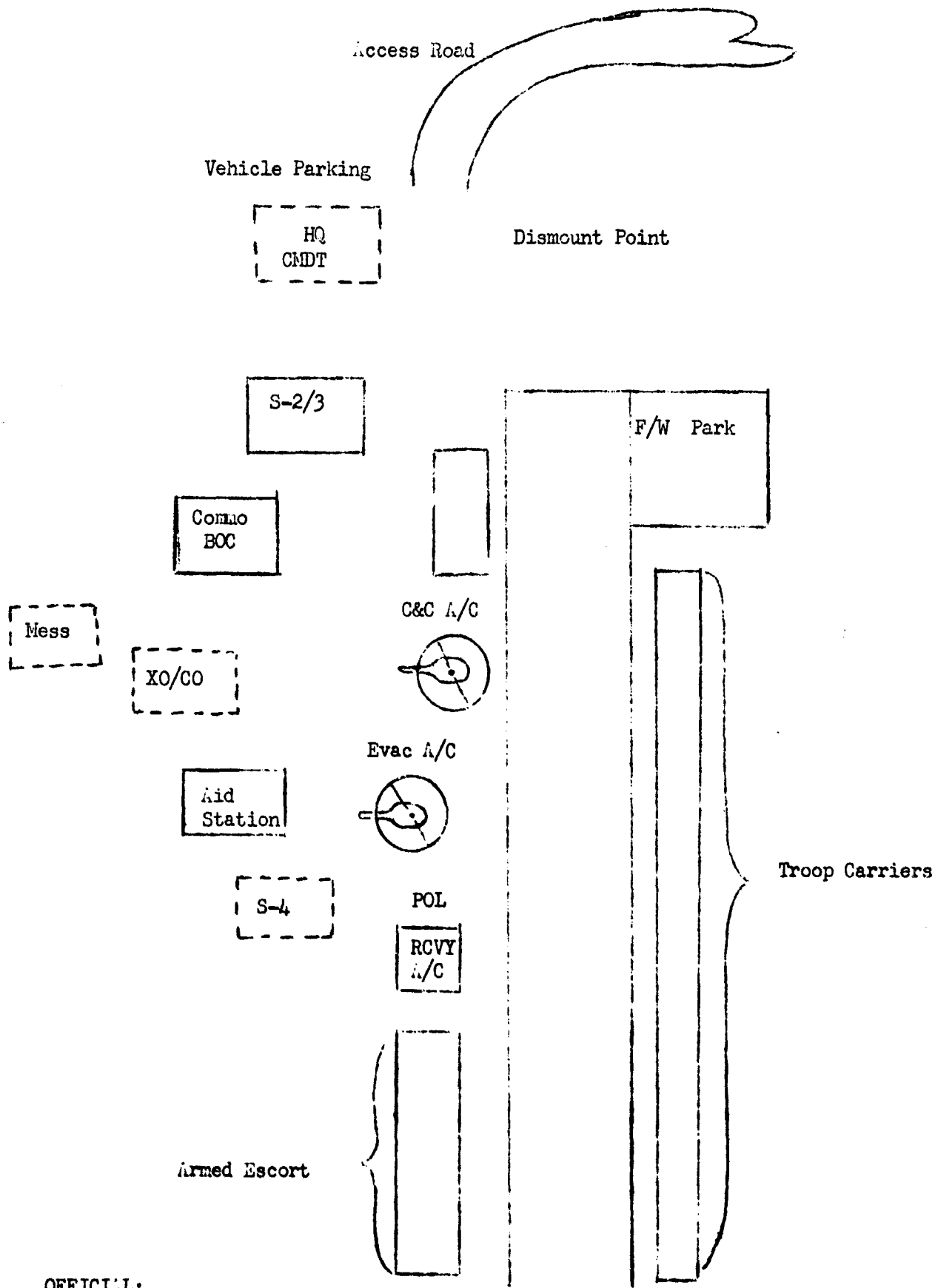

OFFICIAL:

Sauers
SAUERS
S-3

204

FOR OFFICIAL USE ONLY

Appendix 3 (Maintenance and Recovery) To Annex H (Command Post and Stagefield organization and proceedings) to 145th Aviation Battalion SOP for airmobile operations.

1. **PURPOSE:** To outline procedures and duties of the Battalion Aircraft Maintenance Representative at the stagefield during Airmobile operations.

2. **GENERAL:** The Battalion Aircraft Maintenance Representative will be an Officer or Enlisted man provided by the Battalion Maintenance Section. He will be present during all battalion airmobile operations at the stagefield site.

3. **PROCEDURE:**

a. The Battalion Maintenance Representative will report to the Command Post Commander upon arrival at the staging area, and remain under the Command Post Commander's control until released.

b. The Battalion Maintenance Representative (s) will be located in close proximity to the forward CP at the staging area.

c. In fixed staging areas, the Battalion Maintenance Section will provide one (1) representative. One company will be designated during the operational briefing, to provide maintenance personnel for aircraft maintenance support at the designated stagefield.

d. In remote staging areas, the Battalion Maintenance Section will provide two (2) representatives.

e. Recovery of aircraft will normally be coordinated by Command and Control Personnel while airborne (Annex C). If this cannot be accomplished the Battalion Maintenance Representative will coordinate upon notification.

4. **DUTIES:**

a. The Battalion Maintenance Representative will assist, appraise battle damage, and provide technical inspection for all units involved in airmobile operations at the stagefield area.

b. The Battalion Maintenance Representative will record all battle damage, and maintenance incidents, by unit aircraft type, serial number, damage/maintenance discrepancy, for the Battalion After Action Report and Maintenance Section Battalion Historical Report.

c. Upon notification, the Battalion Maintenance Representative will coordinate recovery of aircraft by notifying unit recovery personnel or the 56th Transportation Company Recovery Team (s).

SCHRYER
MAINTENANCE OFFICER

F O R O F F I C I A L U S E O N L Y

205

Appendix 1 (Command Post and Stagefield Equipment) to Annex H (Command Post and Stagefield Organization and Procedures) to 145th Aviation Battalion SOP for Airmobile Operations.

1. **PURPOSE:** To outline the Battalion Command Post and Stagefield minimum required items of equipment during combat operations.
2. **GENERAL:** The HHD Commander is responsible for providing equipment, personnel and supervision for Command Post and Stagefield Operations.
3. **EQUIPMENT:** The following list of equipment is the minimum required items of equipment for non-prolonged Command Post and Stagefield Operations:

a. Items of equipment common to both fixed facilities and field location CP.

- (1) Chairs, folding, steel, 22 ea
 - (2) Table, folding, wood, 6 ea
 - (3) Cot, folding, canvas, (as required).
 - (4) Air Mattress, (as required).
 - (5) Blanket, wool, (as required)
 - (6) Pillow, bed, ctn, tick (as required)
 - (7) Flash lights, 6 ea
 - (8) Candles, 4 doz
 - (9) Insect Repellent, 1 case
 - (10) Foot powder, 1 case
 - (11) Rations, (as required)
 - (12) Jug, insulated, 1 gal, 10 ea.
 - (13) Bag, water, sterilizing, w/poles, 2 ea
 - (14) Can, water, military, 5 gal, 5 ea
 - (15) Lantern, gasoline, leaded fuel, 4 ea
 - (16) Shovel pick & ace, 6 ea
 - (17) CP signs
 - (18) Trunk, locker, wood, 4 ea
- (a) Cup, drinking, hot dring, 450 ea
 - (b) Salt Tablets, w/dispenser, 1 ea
 - (c) Tape, cloth, 4 " Green, 1 ea
 - (d) Engineer Tape, 1 roll
 - (e) Malaria pills

b. Additional equipment required for field location CP.

- (1) Tent, command post, w/poles, 1 ea
- (2) Tent, general purpose, w/poles, (as required)
- (3) Table, wood, 4 ea
- (4) Concertina wire, (as required)
- (5) Sandbags (as required)
- (6) Generator 3 KW
- (7) Light set (25 outlet)
- (8) Field Phones TR 312, 8 ea

OFFICIAL:

SAUERS
S-3

Appendix 2 (Stagefield Arrangement & Aircraft Parking Diagram) to Annex H
(Command Post and Stagefield Organization and Procedures) to 145th Aviation
Battalion SOP for Airmobile Operations

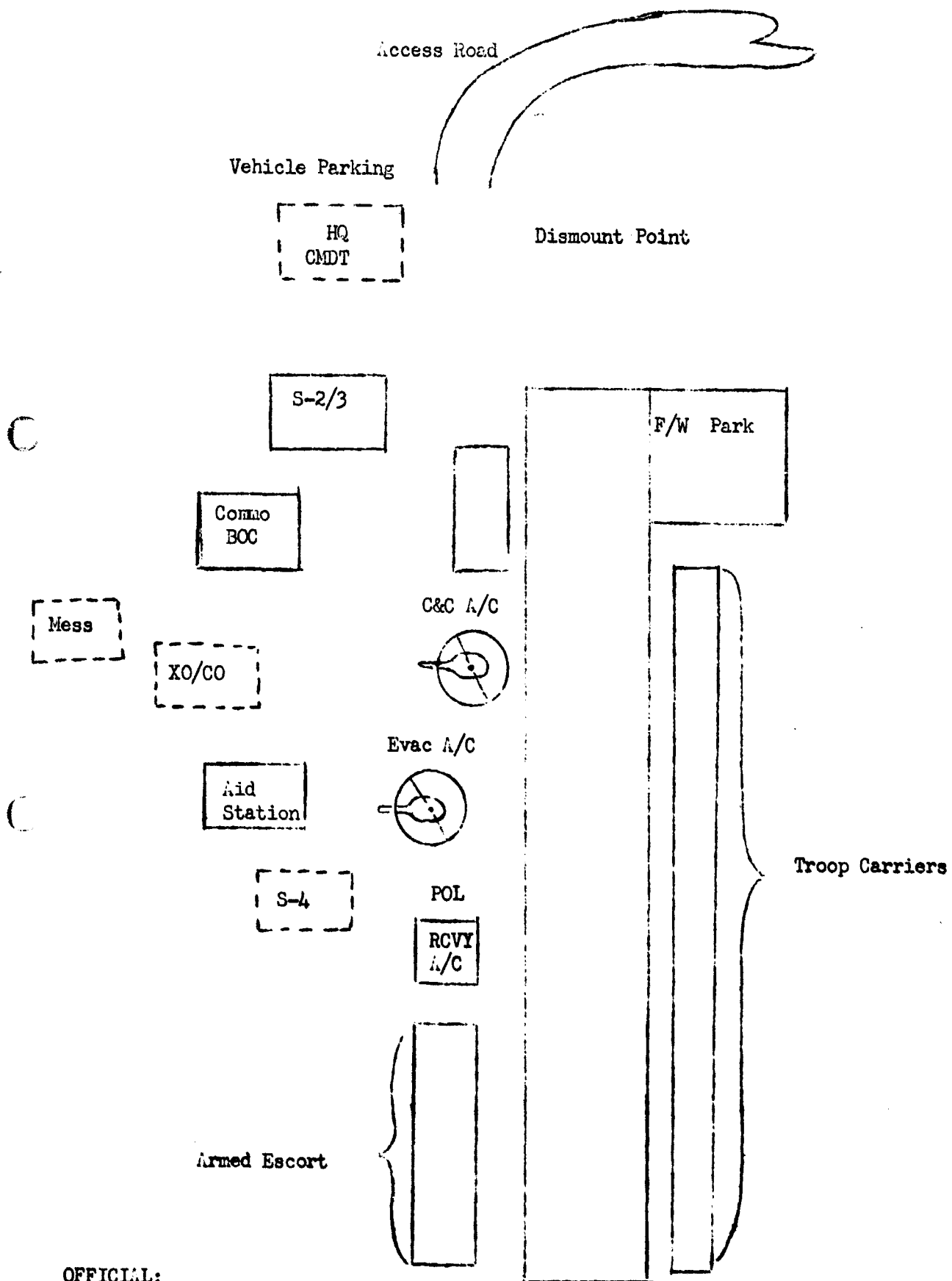

OFFICIAL:

Amers
SKUERS
S-3

FOR OFFICIAL USE ONLY

Appendix 3 (Maintenance and Recovery) To Annex H (Command Post and Stagefield organization and proceedings) to 145th Aviation Battalion SOP for airmobile operations.

1. **PURPOSE:** To outline procedures and duties of the Battalion Aircraft Maintenance Representative at the stagefield during Airmobile operations.
2. **GENERAL:** The Battalion Aircraft Maintenance Representative will be an Officer or Enlisted man provided by the Battalion Maintenance Section. He will be present during all battalion airmobile operations at the stagefield site.
3. **PROCEDURE:**
 - a. The Battalion Maintenance Representative will report to the Command Post Commander upon arrival at the staging area, and remain under the Command Post Commander's control until released.
 - b. The Battalion Maintenance Representative (s) will be located in close proximity to the forward CP at the staging area.
 - c. In fixed staging areas, the Battalion Maintenance Section will provide one (1) representative. One company will be designated during the operational briefing, to provide maintenance personnel for aircraft maintenance support at the designated stagefield.
 - d. In remote staging areas, the Battalion Maintenance Section will provide two (2) representatives.
 - e. Recovery of aircraft will normally be coordinated by Command and Control Personnel while airborne (Annex C). If this cannot be accomplished the Battalion Maintenance Representative will coordinate upon notification.
4. **DUTIES:**
 - a. The Battalion Maintenance Representative will assist, appraise battle damage, and provide technical inspection for all units involved in airmobile operations at the stagefield area.
 - b. The Battalion Maintenance Representative will record all battle damage, and maintenance incidents, by unit aircraft type, serial number, damage/maintenance discrepancy, for the Battalion After Action Report and Maintenance Section Battalion Historical Report.
 - c. Upon notification, the Battalion Maintenance Representative will coordinate recovery of aircraft by notifying unit recovery personnel or the 56th Transportation Company Recovery Team (s).

SCHRIER
MAINTENANCE OFFICER

F O R O F F I C I A L U S E O N L Y

208

Hq, 145th Aviation Battalion
Bien Hoa, RVN
15 April 1966

ANNEX I: (OPERATIONS BRIEFING) To 145TH AVIATION BATTALION SOP FOR AIRMOBILE OPERATIONS

1. SITUATION (S-2/3)
 - a. Weather, enemy and terrain
 - b. Friendly forces
 - c. Attachments and detachments
2. MISSION (S-3)
3. EXECUTION (S-3)
 - a. Concept of Operations
 - (1) Maneuver
 - (2) Fires
 - b. Missions to subordinates
 - c. Coordinating instructions
 - (1) Air Movement
 - (a) Formation
 - (b) Flight route
 - (c) Flight altitude
 - (d) Flight speed
 - (e) Loading
 - (2) Sequence of Events
4. ADMINISTRATION AND LOGISTICS
 - a. Supply
 - b. Maintenance
 - c. Medical
5. COMMAND AND SIGNAL (S-3)
 - a. Signal; Annex _____
 - b. Command
 - (1) CP locations
 - (2) Air mobile force commander
 - c. Time _____

Distribution: Annex Z

JOOST
Lt Col

OFFICIAL

[Signature]
SQUERS

S-3

209

Hqs 145th Aviation Battalion
Bien Hoa, RVN
15 April 1966

Annex J (FLIGHT COMMANDERS DEBRIEFING) to 145th Aviation Battalion SOP
For Airmobile Operations

1. Planning Phase:

- a. Were units informed in time?
- b. Was intelligence accurate?
- c. Was arty or Tac air preparation adequate?
- d. Did aircraft arrive on time?
- e. Were there sufficient aircraft to fulfill the mission?
- f. Was the flight corridor and flight path properly planned for?
- g. Were there any delays?
- h. Were the aircrews aware of the ground tactical plan?

2. Loading Zone:

- a. Was pathfinder properly used?
- b. Were the troops properly broken down?
- c. Was the take-off on time?
- d. Were any difficulties experienced when refueling or rearming?
- e. Was the loading area adequate?

3. Movement Phase:

- a. Were the flight formations adequate?
- b. Were the ACP's and RP easily identifiable?
- c. Was there adequate interval between flight elements?
- d. Was proper air cover afforded the troop carriers?

4. Landing Phase:

- a. Was the landing zone easily identifiable?
- b. Was the landing zone properly marked?
- c. Did the landing zone adequately accommodate the flight formation?
- d. Was suppressive fire allowed?
- e. Was the offensive fire technique used exiting the landing zone?
- f. Did the armed helicopters provide proper coverage?
- g. Other

5. Reserve Employment:

JOOST
Lt Col

OFFICIAL
Sauers
SAUERS
S-3

HQ 145th Aviation Battalion
Bien Hoa, RVN
15 April 1966

Annex K (After Action Report Format) to 145th Aviation Battalion SOP
for Airmobile Operations.

HEADING

File No.

Date

SUBJECT:

TO:

1. TASK ORGANIZATION:

- a. HQ's
- b. Combat Elements
- c. Support Elements

2. MISSION:

3. SUMMARY OF OPERATION:

- a. As Executed
- b. Statistics
 - (1) No. of Aircraft
 - (2) No. Flight Hours
 - (3) No. Sorties

4. ADMINISTRATION AND LOGISTICS:

- a. Supply
- b. Maintenance
- c. Medical

5. PROBLEM AREAS

6. COMMENTS OR RECOMMENDATIONS

HORST K. JOOST
Lt Colonel Infantry
Commanding

OFFICIAL

Sauers
SAUERS
S-3

211

Hqs, 145th Avn Bn
Bien Hoa, RVN
15 April 1966

Annex L (Preplanned Missions) to 145th Aviation Battalion SOP for Airmobile Operations

1. PURPOSE

To establish guidance for both air and ground unit commanders in the conduct of preplanned airmobile operations. The various appendices to this annex serve to expedite planning and decrease reaction times involved in the included operations.

2. SCOPE

This annex includes three types of operations; Eagle Flights, Repetitious Assaults and Birdcage. Each of these operations is covered in detail in the appropriate appendix.

ACKNOWLEDGE:

JOOST
Lt Col

APPENDICES:

1. Eagle Flights
2. Repetitious Assaults
3. Birdcage
4. Aircraft Formations
5. Signal Instructions

DISTRIBUTION:

Annex Z

OFFICIAL:

S. ULERS
S-3

Hqs, 145th Avn Bn
Bien Hoa, RVN
15 April 1966

Appendix 1 (Eagle Flight SOP) to Annex L (Preplanned Missions) to 145th Aviation Battalion SOP for Airmobile Operations

1. PURPOSE

To establish guidelines to be used by air and ground Unit Commanders in training, planning and execution of "Eagle Flight". DEFINITION: "Eagle Flight" is the name given a type mission that is designed to kill, capture and otherwise disorganize isolated Viet Cong units in the field.

2. SCOPE

This appendix will explain the organization, tactical employment, training, and logistics of an "Eagle Flight".

3. GENERAL

The "Eagle Flight" is based on the premise that a small, highly skilled, organized and trained infantry-type combat unit that is one-hundred percent airmobile can produce more Viet Cong casualties in a given time than a much larger organization that is handicapped by an administrative and logistical tail. The success and effectiveness of an "Eagle Flight" unit depends upon its ability to react and maneuver immediately in any combat situation in order to harass and disrupt the activities of the ever moving Viet Cong Guerrilla units. The elements of "surprise" and "shock" are absolute essentials to the success of the "Eagle Flight" mission. The Viet Cong Guerrilla employs "it-and-run" and "hide-and-peek" type tactics to a very great advantage. In essence, the "Eagle Flight" beats him at his own game.

4. ORGANIZATION

An "Eagle Flight" ideally should be composed of the following elements:

a. Command and Control Element, composed of the Aviation Commander (US); Infantry Troop Commander, or his representative. This element will utilize a command & control helicopter. The responsibility of this element will be to select and/or locate appropriate targets for the combat elements; to designate the assault formation and tactics to be employed and be responsible for the command, control and coordination of the overall operation. The only decisions made by the Air Mission Commander will be those necessary to insure that his air elements are employed safely and in accord with their capabilities. Ground tactical decisions will be made by the Airmobile Force Commander or his representative.

b. Troop carrier element is composed of seven (7) UH-1D helicopters, unarmed and equipped as troop-carriers. Six (6) of these aircraft will be utilized to transport the combat element; the seventh, to transport prisoners taken and as an emergency-rescue aircraft.

c. Escort element is composed of five (5) armed UH-1B helicopters whose primary mission is to safeguard the troop carrier element; with an equally important additional mission of providing protection by fire for the ground troops.

d. Medical evacuation element is composed of one (1) UH-1B helicopter, equipped and manned for the sole purpose of evacuation of friendly casualties. This element will not be used as a prisoner-transport.

e. Combat troop element, composed of six (6) squads of nine (9) men each. Each two (2) squads, if ARVN, should be accompanied by an American Advisor for control and communication purposes. Troops should be trained and employed in two-squad elements. In addition, the American Advisor to the ARVN troop commander should accompany the element. The troop element must be made up of selected, highly aggressive, well-trained troops, armed with automatic weapons.

5. **TRAINING:** All elements must undergo a training period as a unit, during which time they will learn to function as a single well-drilled combat team. The combat troop element and the troop carrier element should train together for a minimum of two (2) full days, with all elements participating the last day. A live firing problem should be conducted on the afternoon of the last training day in order to accustom the ground troops to the fire of armed escort helicopters at close quarters. During this last exercise, simulated emergencies, such as medical evacuations, fire requests and problems of all types should be practiced. All visual air to ground and ground to air signals should be brought into play. Special emphasis should be placed throughout the training period on the use of the two squad element and tactical deployment from the various aircraft landing formations (Appendix 4). Ground commanders should be thoroughly oriented in the selection and marking of adequate landing sites to facilitate troop pick up.

6. CONDUCT OF THE OPERATION:

a. Prior to each mission, close coordination between the troop carriers, armed helicopters and the ground force commander is essential. The following coordination must be affected:

- (1) Sequence of events
- (2) Possible landing zones (S-2 report)
- (3) Radio frequencies, call signs; calibration of ground to air radios
- (4) POW pick up and collecting points
- (5) Pyrotechnics
- (6) Emergency signals
- (7) Logistics (Aircraft fuel range and refueling points)

b. Reconnaissance : The enroute flight formation for troop carrying helicopters is two-ship echelons, at a trail (Appendix 4). Armed helicopters provide escort by using normal flank-escort formations. Two minutes ahead of the troop carrying element, the Escort Element Leader accompanies the Command and Control Element to reconnoiter the objective area, leaving four (4) armed helicopters to escort the troop carrying helicopters and medical evacuation helicopter. After target selection and reconnaissance, the Escort Element Leader will return to the main column as the Command and Control Element issues the attack order. The attack order will include:

- (1) Enemy situation in the landing zone
- (2) Instructions for pre-strike (when applicable)
- (3) Landing formations to be employed (Appendix 4)
- (4) Direction of landing and departure for troop carriers

c. The Attack: After the attack order has been issued the troop carriers will commence their approach to the landing zone, led by the Command and Control Element and escorted by the armed helicopter unit (provided this element is not engaged in a pre-strike). In any case, the Escort Element will terminate pre-strike in sufficient time to provide flank security for the Troop Carrier Element during the last three-hundred (300) meters of the approach. The Command and Control Element, preceding the Troop Carrier Element by approximately one (1) minute, will mark the landing zone with smoke (Appendix 5) and give instructions for landing with relation to the smoke marker (Appendix 1 for formations to be used).

After the troops have dismounted, the unarmed helicopters will orbit at an altitude of twenty-five hundred (2,500) feet, one mile away from the landing zone, standing by for pick-up instructions. Fire teams (armed helicopters) continue coverage of their respective flanks of the landing zone (troop element). Normal low-level orbits below one-hundred (100) feet will be used to reconnoiter the area and provide the ground force with aerial flank security. Ground forces can call for armed helicopter fire to point targets by radio or visual signal (Appendix 5).

d. Apprehension of Prisoners: When Viet Cong are observed fleeing the objective area, the armed helicopters will attempt to halt their escape by fire. Every effort will be made to drive the suspects to an area where ground forces can capture them. The commander may commit the reserve element, or airlift elements from the objective area in order to block and/or apprehend fleeing Viet Cong.

If necessary, the armed helicopters will capture prisoners. One aircraft will land to pick up the prisoner, while the other team element provides cover. The aircraft providing cover will be positioned so that fire may be placed in the vicinity of the pick up aircraft or it's crew. The observer, under supervision of the crew chief, will thoroughly search and secure the prisoner at a safe distance from the aircraft. The gunner will place himself in a position to cover the crew chief and observer. If it is evident that the apprehension will in any way endanger the aircraft or crew, the Viet Cong will be killed. Any crew-member or the observer is authorized to kill the suspect if he commits an overt act which will endanger the helicopter or it's crew. Whenever possible, a rendezvous will be made with the prisoner transport aircraft, so that he may secure the prisoners enroute to the staging area.

The reserve may be used to capture prisoners (see above paragraph), or to reinforce or block any area deemed necessary by the commander. The reserve may be called in either by radio or by visual signal (Appendix 4).

2. Pick-up of ground forces: Ground forces and aircraft will be called in by the ground commander (Appendix 5). Armed aircraft will provide normal flank security during the pick up and departure. The Command and Control Element should keep the ground commander appraised on the aircraft fuel status and the remaining time available for him to operate on the ground. The Ground Commander should plan and conduct his operation to make maximum utilization of a short ground operational period. It is feasible to strike more than one objective without aircraft re-fueling.

NOTE: If fuel runs short, helicopters may be dispatched in elements for refueling in order to maintain constant support to the element operating on the ground. However, this procedure should be avoided whenever possible, since it somewhat restricts the air-maneuverability and aerial fire protection of the ground element.

3. Special instructions to the Mission Leader: Due to the complexity of the Eagle Flight, operations must be planned in detail and a detailed mission order and briefing conducted. The mission order must be clearly understood by all aviators and crew-members. Whenever possible the ground advisor should be present at the briefing to facilitate coordination. Special emphasis should be placed on the following:

- (1) Map reconnaissance of the operational zone.
- (2) That each aircraft crew knows its mission and position in the strike force.
- (3) Flight and landing formations are clearly understood.
- (4) Crew chiefs, gunners and observers are briefed on the apprehension of prisoners.
- (5) Prisoner collecting points are pre-designated. Whenever possible, pick up points in the objective area are pre-designated.
- (6) Aircraft and ground radios are operational and calibrated.
- (7) Smoke and emergency signals are understood.
- (8) Crews are cautioned on delivering fire in the close proximity of other aircraft and personnel in and around the objective area.

OFFICIAL:

SAUERS
S-3

Hqs, 145th Avn Bn
Bien Hoa, RVN
15 April 1966

Appendix 2 (Repetitious Assaults) to Annex L (Preplanned Missions) to
145th Aviation Battalion SOP for Airmobile Operations.

1. PURPOSE:

To exploit the mobility of the helicopter to lift assault forces in frequent and repetitious airmobile assaults to quickly search out and destroy the Viet Cong over a large area. Surprise, shock action, and security are achieved by the delivery of a high volume of artillery, tactical air and armed helicopter fire support in the assault landing zone in the shortest possible period of time prior to landing of the troop carriers. All possible consideration should be given methods to vary the fire support to avoid a stereotyped operation.

2. SCOPE:

This appendix will explain the organization and tactical employment of the airmobile phase of a repetitious assault operation.

3. GENERAL:

The repetitious assault disposes a number of self-contained fighting elements over a large area of operations in a short period of time, with a minimum debilitation of infantry elements. The prerequisites for the use of repetitious assaults are an abundance of helicopter landing zones, open terrain with good fields of fire and observation, within range of supporting artillery and or naval gunfire, tactical or strategic air support, adequate troop carrier and armed helicopters and loosely organized enemy situation.

4. ORGANIZATION:

A repetitious assault should ideally be organized as follows:

a. Command and Control Element: Composed of the Air Mission Commander, Air Mobile Force Commander, Air Mission Operations Officer, Artillery Liaison Officer, Air Liaison Officer, (a Naval Gunfire Liaison Officer will be included if necessary). This command element directs the selection of the landing zones, the introduction and extraction of ground elements, employment of fire support and the employment of the reaction force to reinforce an employed element. An alternate command and control helicopter should be provided and fully staffed by deputies who are knowledgeable of the situation and capable of making command decisions. This aircraft will be utilized to relieve the primary command and control helicopter on station when refueling is necessary or to replace it should it become disabled, thereby insuring a continuous command and control of all elements.

b. Troop Carrier Element: Must be of sufficient strength to lift the combat elements of a rifle company. Greater shock action and shorter turn around times may be achieved by using a greater number of troop carriers in simultaneous assaults on multiple landing zones.

c. Escort Element: Should be composed of at least two light fire teams per company sized element. These aircraft should be utilized for troop carrier escort, landing zone reconnaissance, marking and preparation and if needed provide overhead cover for ground operations.

d. Combat Troop Elements: Are formed into assault task forces up to company size by the ground battalion responsible for the execution of the repetitious assaults.

5. Conduct of the Operation:

a. Prior to each operation joint coordination in the following areas must be effected:

- (1) Flexible sequence of events
- (2) All possible landing zones, with code names
- (3) Radio frequencies, call signs; calibration of ground to air radios.
- (4) Pyrotechnics and emergency signals.
- (5) Logistics (aircraft fuel range and refueling rearming points)
- (6) Reconnaissance
- (7) Weather delays
- (8) Fire support
- (9) Reserves

b. To initiate a repetitious assault operation the airmobile force commander announces "Skyhook + LZ code name" at a predetermined ground reference point. This reference point is selected to be a prescribed flight time away from the landing zone. The artillery liaison officer and air liaison officer in the Command and Control helicopter then initiate immediate artillery and air preparation of the landing zone. This consists of a high volume of fire of three to five minutes duration. Colored smoke rounds are fired to signify last rounds. During this preparation the troop carriers and their escorts fly inbound to the landing zone so as to be on final as the preparation ends. At this point armed helicopters precede and fly to the flanks during the landing suppressing any enemy fires that may interfere with the assault. On landing the ground assault forces deploy rapidly from the landing zone to search out and destroy enemy forces in the area. Preplanned fires should be varied, for example, instead of artillery it may be appropriate to use just air support, armed helicopters or any combination thereof.

c. After the first operation the helicopters return to the battalion base to pick up the next task force. When airborne, the same sequence is repeated, this assault takes place in a different predesignated area which may contain enemy forces. The distance that this force lands from the first may preclude mutual support between forces. While the second assault element is airborne, the status of enemy contact of the first force is determined. If contact is heavy the second assault force may be used as a reaction force to reinforce or to block for the first force.

d. The remaining infantry company is then picked up and may be used to assault a new location by the same procedure as described for the first two. At the completion of the last assault, the battalion is situated in three separate locations. After a predesignated time, or on call, when contact with the enemy is unattainable, or has ceased, the helicopters return to pick up one of the employed forces to begin the sequence anew.

e. When as many as two companies of the first committed battalion are employed, a task element from another battalion must be designated as the reaction force, effective on commitment of the third company. Two battalions may be employed in this manner in sequence.

6. TRAINING: Repetitious assault operations are battle drill type operations that can be refined and executed with precision through training and experience. All elements should undergo a training period as a unit, during which time they will learn to function as a single well-drilled combat team. This training should stress visual ground to air signals, communications, simulated emergencies, and extraction operations. An orientation covering the selection and marking of landing zones to facilitate troop extraction should be scheduled for ground unit officers and key NCO personnel.

OFFICIAL:

SAUERS

S-3

Hqs, 145th Avn Bn
Bien Hoa, RVN
15 April 1966

Appendix 3 (BIRDCAGE SOP) to Annex L, (Preplanned Missions) to 145th
Aviation Battalion SOP for Airmobile Operations

1. PURPOSE

To establish guidance to be utilized by air mobile commanders in initiation and execution of "BIRDCAGE" operations. Definition: "BIRDCAGE" is the name given to an operation designed to protect aircraft downed in hostile territory.

2. SCOPE

This appendix describes the organization and utilization of "BIRDCAGE" task elements to protect downed aircraft.

* 3. GENERAL

The "BIRDCAGE" operation is based on "OPLAN BIRDCAGE", Headquarters 173rd Airborne Brigade (sep) and its use will be coordinated with the C-3, 173rd Airborne Brigade. This operation is based on the premise that an aircraft is down in hostile territory in or near the 173rd Airborne Brigade, TAOR. Any aircraft commander or ground commander may initiate "BIRDCAGE" by utilizing the code word "BIRDCAGE" plus the location of the aircraft. This information should be given either to 145th Aviation Battalion Operations Center or 145th Aviation Battalion command and control aircraft.

4. MISSION.

145th Aviation Battalion provides troop carriers and armed helicopter escort for the airmobile force. 173rd Airborne Brigade supplies airmobile force to consist of one reinforced rifle platoon (TASK FORCE BIRDCAGE), for the purpose of protecting a downed aircraft in a hostile area until it is repaired or evacuated. This rifle platoon will have a commissioned leader and be reinforced by one 81 mm mortar squad

Oplan "BIRDCAGE" is currently under study by II Field Forces Vietnam for use as a standard downed aircraft protective measure throughout their area of operations.

OFFICIAL:

Sauers
SAUERS

S-3

AIRCRAFT FORMATIONS

1. Enroute and holding formation will be two ship echelons at trail, with escort aircraft providing flank security:

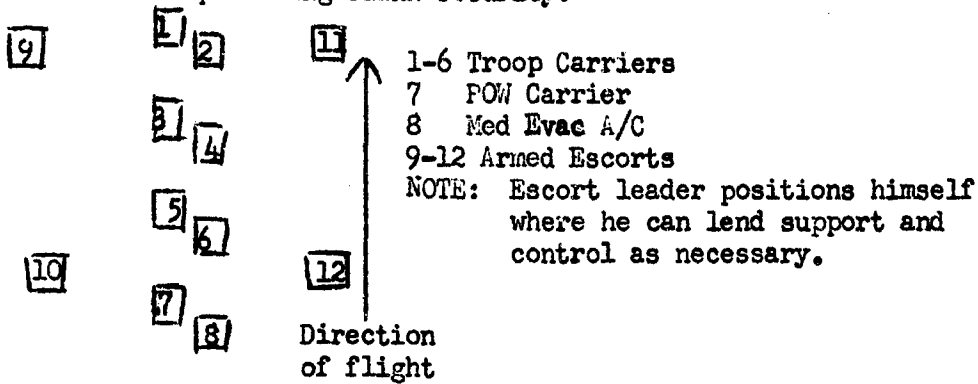

2. Aircraft landing formations:

a. "L-right." This formation and the "L-left" utilize one wing of the "L" as a base and the other as a maneuvering (clearing) element. Fire and base elements are varied to meet the situation.

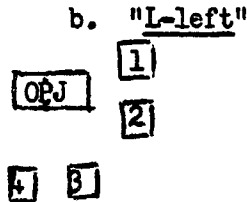
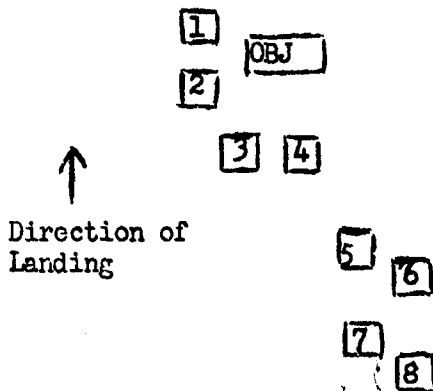

5-8 elements kept in airborne reserve until needed. Altitude 2,500'.

c. "Trail-right" or "trail-left". Whether formation is right or left depends upon the relation of the objective to the landing area. If the objective is to the right, than a "trail-right" is used and the troops exit the aircraft and form assault line to the right; if the objective is to the left, then the reverse is true..

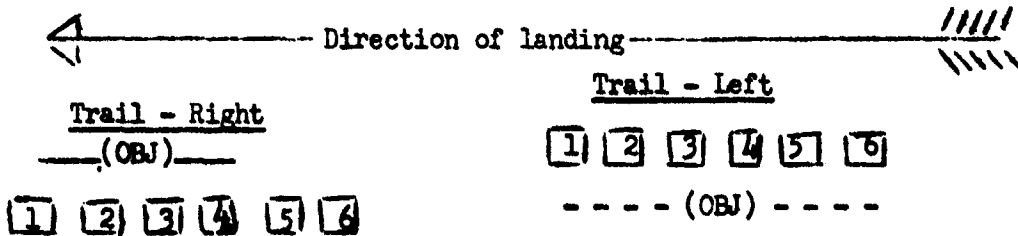

OFFICIAL:

SAUERS
 S-3

In either the "trail-right" or "trail-left" formations, four (4) or six (6) squads may be initially committed. It is highly recommended that two (2) squads be retained as a heliborne reserve, to be committed later as needed.

d. The "Box" formation is used to place concentration of troops in a confined landing area, such as a river-junction, etc. In this formation, a two-ship reserve is utilized.

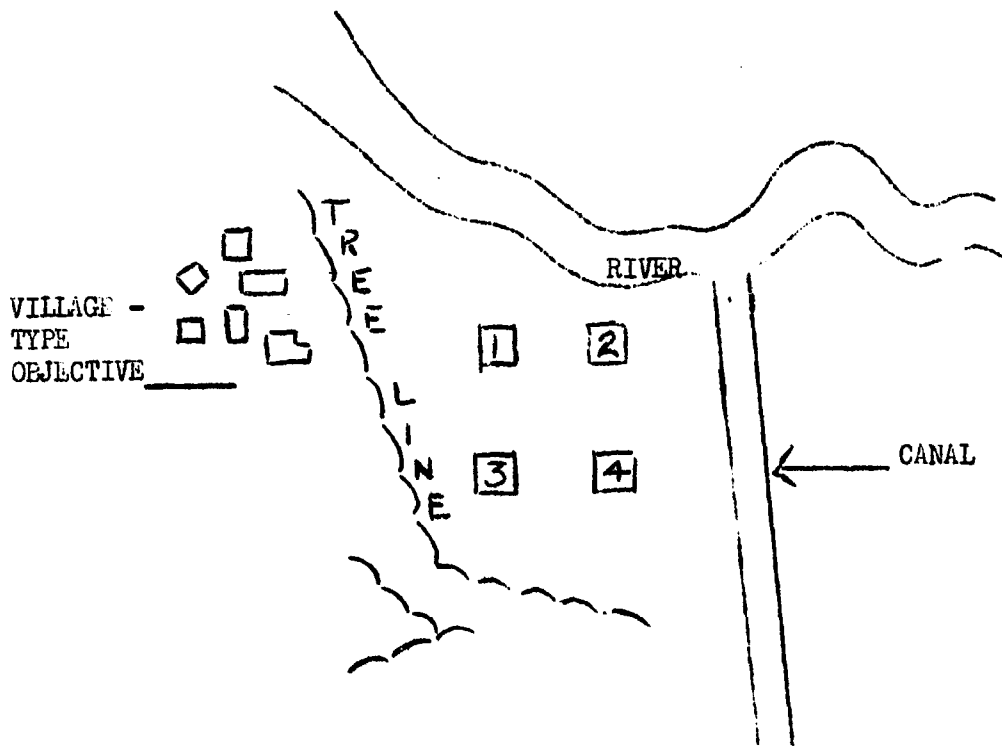

OFFICIAL:

SAUERS
S-3

F O R O F F I C I A L U S E O N L Y
L-1-2

222

Appendix 5 (Signal Instructions) to Annex L (Preplanned Missions) to
 145th Avn Bn SOP for Airmobile Operations.

1. Smoke Signals:

- RED SMOKE.....Medical Evacuation Desired
- YELLOW SMOKE.....Commit Reserve - land as near smoke as possible
- GREEN SMOKE.....Pick-up troops (1st Squad at Smoke)
- WHITE SMOKE.....Target for armed helicopter support element
 (LUNNY POSITION)
- VIOLET SMOKE.....Friendly Troops

2. Co-pilot visual (drawn) and hand signals are utilized prior to landing to insure that all troop elements are fully aware of the forthcoming ground maneuver.

a. An acetate covered board is used initially to indicate the type formation to be used and the side of the aircraft from which the troops are to exit.

2nd ship in "L" right 4th ship in "L" left 3rd ship in line right

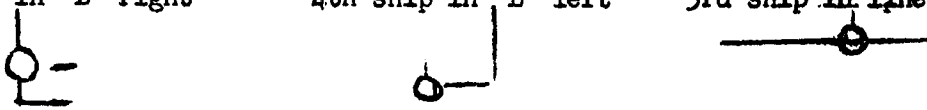

b. Just prior to landing, a thumb signal is given by the co-pilot to indicate which side of the aircraft the troops are to exit from.

- (1) Right hand (thumb-up).....exit right door & assault right
- (2) Left hand (thumb-up).....exit left door & assault left
- (3) Both hands (thumb-up).....exit both doors & assault both directions

3. Fire requests from ground to air and requests for cease fire.

- a. Emergency cease fire.....Red flare (vary pistol)
- b. Panel Marking

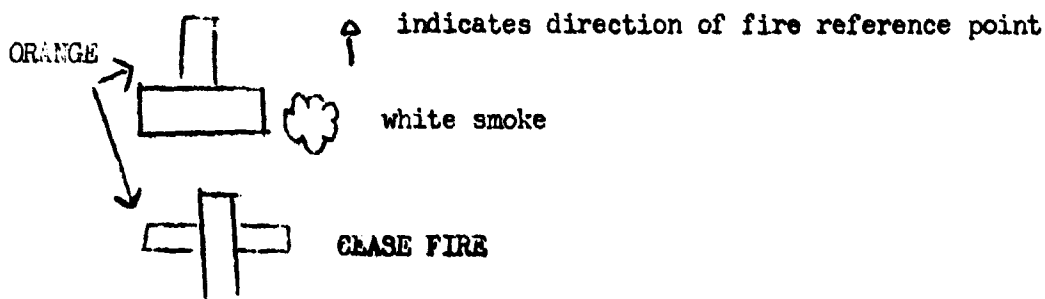

OFFICIAL:

SAVERS
 3-3

FOR OFFICIAL USE ONLY

4. Troop identification using colored markers. a. (for Eagle Flight Operations Only)

a. Each squad can be readily identified from the air by the use of colored scarves, one per individual. Each squad should be assigned a different color and each member of that squad required to wear a neckerchief of his squad's color. This insures that the aircraft crews can readily identify the squads that their aircraft is transporting. This is important in that tactical integrity must be maintained on troop pick-up to insure proper deployment on the next objective.

b. It is recommended that dayglo marker panels be carried by the flank men of each squad (2 men per squad). These panels should be of standard size, dayglo orange on one side and dayglo red on the other. One end of the panel should be secured to the individual's shoulders, with the orange side out and secured at the waist (back) with the excess rolled under and secured. In this position the panel readily indicates to aerial elements the flank limits of each squad, reducing the possibility of mis-directed firing into friendly elements. To request fire, or to call cease fire, the rolled up portion of the panel is released and allowed to hang full length. The individual assumes a prone position exposing the panel to full aerial observation; two individuals used together make up the panel signals. When the bottom of the panel is pulled to the individual's shoulders exposing one-half ($\frac{1}{2}$) of the red side, and green smoke has been utilized, it indicates the squad pick up point, enabling the helicopters to more readily identify the individual squad positions.

OFFICIAL:

SAUERS
S-3

Hqs, 145th Avn Bn
Bien Hoa, RVN
15 April 1966

Annex M: (Suppressive and Offensive Fire) to 145th Aviation Battalion SOP
for Airmobile Operations.

1. **PURPOSE:** To exploit the offensive fire capability of the troop carrier helicopter and organic armed escort, within the rules of engagement, and the requirement for combat and combat support. It is further designed to give individual gunners and armed helicopter personnel confidence in their weapons, improve their accuracy and enable unit commanders to exercise and control their fire capability.

2. **DEFINITIONS:**

a. **Suppressive Fire:** Those organic fires utilized to protect troop carriers from hostile fire during the critical final approach and initial climb out phases of an airmobile assault.

b. **Offensive Fire:** Those organic fires utilized to support the ground tactical plan by placing a concentrated volume of fire on a target jointly approved by the airmobile force and air mission commanders.

3. **GENERAL:** Suppressive firing techniques will be used as required to suppress the flight route during final descent and approach on combat assaults into hostile landing zones. During extractions, the last flight out of the landing zone will utilize this procedure to place maximum suppressive fire on the enemy along the departure and climb out routes. Offensive firing will be conducted during diversionary airmobile operations to give added realism to deceptive plans. In addition, this technique will be used in conjunction with the ground tactical plan on known or suspected enemy positions to channel the enemy into areas occupied by friendly forces or to block the enemy retreat from the operational area immediately after an airmobile assault.

4. **PROCEDURE:** The exercise of this technique will be in specified strike zones established by the ground commander concerned or executed within the rules of engagement. Unit commanders or aircraft commanders will give the order to commence firing and to cease fire. Altitude limits of offensive fire will be from 2000 feet absolute altitude down to 1000 feet absolute altitude, enemy situation permitting; however, suppressive fires may be utilized at any altitude.

5. **DESIRED RESULTS:** To render maximum aerial firepower in support of the ground tactical plan by placing a concentrated volume of fire on known or suspected enemy targets in order to destroy enemy forces, supplies, and installations. This technique also allows the exercise of rigid control and control of fires by unit commanders and aircrews. Properly employed it will destroy the enemy, disorganize and deceive him, seal his escape routes and assist the maneuvering ground forces.

JOOST
Lt Col

OFFICIAL

SAUERS
S-3

725

ANNEX N (Chemical Delivery) to 145th Aviation Battalion SOP for Airmobile Operations.

1. PURPOSE: To establish guide lines and procedures to be used in the aerial delivery of chemical grenades, specifically smoke and tear gas (CS).

2. GENERAL:

a. The delivery of chemical grenades as a harassing agent is used to assist air and ground movement into areas previously occupied by the Viet Cong where prepared positions are prevalent. The aerial delivery of chemical agents prior to airmobile assaults provides additional flexibility to the Air Mission and Airmobile Force commander. Variations to the standard delivery method as outlined in this SOP may be employed by the Air Mission Commander as necessary to adjust to the tactical situation.

b. Helicopter Delivery System

(1) Troop Landing Smoke Screen System: serial number DA-01-021-AMC-11594Z.

(2) Jury Rig System: utilizing two Air Force rocket pods (19 tubes).

c. Rigging:

(1) The Troop Landing Smoke Screen System (ref 2 (b) 1) is adaptable to the M-3 aircraft armament system. The M-3 modules are reversed so the chemical grenades are dispensed aft rather than forward. The adapter plate (firing mechanism) assembly is attached to the modules and electrically connected to an intervalometer or control box located inside the aircraft. The intervalometer receives its power source from any one of the electrical outlets in the cargo compartment and is mounted so that either the co-pilot or a crew member can fire the grenades on order from the aircraft commander. The weight of the system loaded approximates that of a loaded M-3 armament system. There are six grenades per rocket tube and a total of two hundred and eighty eight in the system. Different airspeeds can be used for drop separation, however, dispensing intervals must also be adjusted on the intervalometer located inside the aircraft. To obtain the best coverage and incapacitating time, a drop separation of 8-10 feet should be used. The following air speeds and time sequence will result in optimum spacing.

50 Knots - 0.5 sec
90 Knots - 0.3 sec
100 Knots - 0.2 sec

The recommended airspeed is 90 knots and 0.3 second time adjustment. Utilizing this drop separation one M-3 system will be expended each 2,304 feet or 750 meters, and time lapse will be 16 seconds. Fuze delay is 2 seconds from drop, therefore flight altitude will be low level or not higher than 50 feet. Incapacitation time will last from 15 seconds to 15 minutes depending on meteorological conditions and density of coverage. The effective radius of the grenade at zero wind speed is 15 meters. For optimum coverage (35 meters) a light,

steady wind of 3-5 knots is best; winds higher than 7 knots tend to dissipate the chemical agent rapidly and incapacitation time is reduced.

(2) The jury rig system (ref (b) 2) is composed of two rocket pods (19 tubes) lashed to the cargo deck of a UH-1H helicopter. The rocket tube is loaded with eight grenades and manually dispensed. Rocket pods will be staggered, one lashed forward and one aft, to allow the crew members freedom of movement, with the manual plunger. Tube loading for this system is eight grenades per rocket tube with a total capacity of 304 grenades. The system is employed in the same manner and with the same results as the Troop Landing Smoke Screen System; however, more crew training is required to obtain optimum results, and more time is required to load this system as no loading tray or tube is available. In addition, the grenade safety lever must be bent outward at the fuze end to insure the plunger does not fall and activate the grenade while in the rocket tube, or the grenade fall out prior to arrival in the objective area.

(3) In using both systems, the safety pins will be pulled during loading. Safety pins should be retained in order to resafety the grenades if all are not utilized.

d. Employment:

(1) In utilizing either system, the method of employment will be the same. Because of the fuze timing, the delivery must be made at low level altitudes; therefore, a fire team escort is required to suppress or neutralize areas of hostile fire during the low level delivery. In addition, an M-3 or M-5 system will precede the chemical dispensing helicopter firing white phosphorous rockets to mark the objective and the exact drop route. The smoke produced will aid in confining the chemical agent in close proximity of the ground in the objective area, and insure its maximum concentration. If multiple passes must be made, the normal hostile fire evasive tactics for helicopters will be executed.

(2) Protective Mask Utilization:

(a) Loading: During the process of loading and arming the system, all members of the loading team will wear the M-24 protective mask in case of any unexpected discharge of the chemical agent being prepared for delivery. Should such an emergency arise, the standard "GAS" alarm will be sounded so as to warn others who are in close proximity to the loading team.

(b) Masking for Delivery: Prior to departing the staging area enroute to the delivery area, two members of the flight crew will mask in case of an emergency enroute. (is a round from a hostile weapon may enter the rocket pod and ignite one or more of the loaded grenades). Prior to initiating the low level pass all members of the flight crew will wear the M-24 protective mask.

(c) Unmasking: At the termination of the aerial delivery, and after the helicopter has gained sufficient altitude and is up wind from the drop zone the following unmasking procedures will be adhered to. The gunner will unmask first; if any of the chemical agent is detected he will immediately mask and wait for a brief period of time. If none of the agent is detectable the remainder of the flight crew will unmask one at a time in the following sequence, crew chief, aircraft commander, and pilot.

(3) This SOP is designed to be used as a guide and a reference from which future employment of this weapons system can be expanded. However, the rigging of each system as outlined in paragraph 1c results in the optimum concentration and time spacing of this delivery system.

JOOST
Lt Col

OFFICIAL:

Sauers
SAUERS
S-3

Annex O (Pathfinder Detachment) to 145th Aviation Battalion SOP for Standard Operation Procedure.

1. GENERAL: The mission of the Battalion Pathfinder Detachment is to provide navigational assistance to army aircraft and to organize and expedite the loading of troops, equipment, and cargo of the supported unit.

2. PLANNING:

a. At least one Pathfinder Officer will accompany the Battalion Liaison Officer on his initial visit to the supported unit.

b. Pathfinders will coordinate with the ground unit commander or his designated representative the following:

- (1) Loading area
- (2) Landing formation and location of lead element
- (3) Time for the troops to be at the loading area
- (4) Number of troops per lift
- (5) Number of troops per aircraft

c. Pathfinders will prepare and conduct a briefing with diagrams of the pick-up zone, showing as a minimum:

- (1) Navigational aids
- (2) Landing direction
- (3) Landing formation
- (4) Obstacles

3. EXECUTION:

a. Staging Area: In executing airborne operations the 145th Aviation Battalion will stage from an improved landing strip or helipad normally the SHARFIT.

(1) During day-light operations pathfinders will be on location to indicate by arm and hand signals, radio, or smoke touch down points of flight elements and individual aircraft.

(2) During night operations pathfinders will mark the four corners of the area with blue "blue bag" lights. The touchdown point of the lead aircraft of the first flight element will be indicated with a "T" utilizing five amber lights. The "T" will be relocated to indicate touch down point of the lead aircraft of subsequent elements.

FOR OFFICIAL USE ONLY

b. Pick-Up Zones:

(1) Pathfinders will arrive at the pick-up zone 30-45 minutes prior to arrival time of the first flight element.

(2) Pathfinders will direct aircraft by radio, smoke, lights or navigational beacons. Hand and arm signals with lighted batons will be utilized for sling loads if applicable.

c. Landing Zone: If requested, the pathfinder team will accompany the lead flight element into the landing zone and accomplish the following:

(1) Mark the touchdown point of subsequent lead aircraft by the use of a panel or smoke.

(2) Give landing directions by radio to inbound aircraft.

(3) Remove obstacles or mark them with red panels or lights as time permits.

(4) During night operations mark the limits of the LZ with blue lights.

(5) Assist in directing fire of gunships in the event the LZ is under hostile fire.

d. Extractions: Pathfinders will be utilized in extractions to:

(1) Aid the supported unit in the rapid loading of troops, equipment and cargo.

(2) Perform all the duties listed in para 3c above.

4. ADMINISTRATION: Stagefield diagrams will show areas for parking of all aircraft flights, gunships, refueling facilities, rearming facilities, avionics and maintenance assistance, C&C aircraft, VIP areas, and aid station.

5. SIGNAL:

a. Upon arrival at the operational area the air to ground radio will be the first item of equipment to become operational. Air to ground communication will be maintained with flight elements at all times. The air to ground radio will be the last item taken out of operation.

b. Visual communication will be utilized as directed in preceding paragraphs.

JOOST
Lt Col

OFFICIAL:

[Signature]
SAUERS
S-3

Annex P (Landing Zone Preparation) to 145th Aviation Battalion SOP for
Airmobile Operations

1. Purpose: To define the numerous variations of landing zone preparation available to both the Airmobile Force and Air Mission Commanders which will enable them to prepare a landing zone prior to a heliborne assault without becoming stereotyped in their method of preparation.

2. Scope: This annex will explain in detail the various methods of landing zone preparation available to the Airmobile Force and Air Mission Commander.

3. General: Landing zone preparation techniques are based on the premise that the harder you can hit the enemy prior to landing a heliborne assault force, the more disorganized and bewildered he will be; enabling the air landed force to gain an easy foothold once in the landing zone. Basic doctrine for such tactics is very sound, however continuous repetition of the same technique creates stereotyped operations, thus eliminating the flexibility, fire power and element of surprise which is required to overcome the defender. The inability of individuals to rapidly react to the unknown and unexpected creates unrest, chaos, and disorganization which in itself opens the door leading to immediate and continuous success. In order to create an atmosphere of unrest and fear of the unknown, new and different techniques of landing zone preparation must be developed which do not in any manner follow the same pattern or sequence of events.

4. Methods of Landing Zone Preparation:

a. Several methods of landing zone preparation have been developed and used in the past. These methods have included the use of several different agencies in order that maximum devastation might be brought in and around the landing zone(s) in a minimum amount of time.

b. Agencies and methods to be discussed in this annex include:

- (1) Tactical Air Power
- (2) Artillery Preparation
- (3) Naval Gun Fire
- (4) Strategic Air Power
- (5) Armed Helicopters
- (6) Offensive Fire
- (7) Troop Landing Smoke Screen System
- (8) MAD (Mortor Aerial Delivery)
- (9) Preparation of Dummy Landing Zones
- (10) Feint

c. All methods included in this annex have the capability of disorganizing a strong Viet Cong force in such a manner that he is unable to react immediately to a rapidly changing tactical situation and thus becomes decreasingly effective against an airmobile combat landed assault. The "element of surprise" which is created through the use of different methods of landing zone preparation can, if effectively employed, become a major asset to the ground commander.

The flexibility afforded the attacker is equal in combat ratio to having a unit in reserve ready to react on a moments notice.

(1) Tactical Air Power: This agency is undoubtedly the strongest of our "Strong Right Arms". Its capability should never be underestimated, and the versatility of available ordnance allows for flexibility in any plan of operation. The type of ordnance and method of drop will depend on several factors; ie disposition of troops, type of landing zone, location of landing zone, time of combat assault, desired effect. The tactical air power must always be immediately responsive to the air mission commander in order to adjust to the rapidly changing situation of any combat environment.

(2) Artillery Preparation: Artillery preparation of a landing zone is undoubtedly the oldest and most used by the ground commander. However, due to its stereotype employment prior to any large scale operations, it has lost its capability of maximum devastation. Variations of artillery barrages and concentration must be utilized at different times and places in order to throw the Viet Cong off balance so that he never knows "Exactly" when or where the combat assault is going to occur. Then and only then can this support agency do an adequate job of preparing a landing zone prior to an airmobile combat landed assault.

(3) Naval Gun Fire: Due to its location and restriction of movement, naval gun fire is often disregarded as an available source for landing zone preparation. However, on numerous occasions this service can be used very effectively to prepare several likely landing zones, thus causing the Viet Cong to become confused as to which landing zone would actually be chosen. A positive means of radio contact with the vessels involved would create an atmosphere of direct response which in turn can be utilized to the advantage of the Air Mission Commander.

(4) Strategic Air Power: A classified means of delivering maximum devastation against a Viet Cong force fortified in or near a proposed landing zone. Coordination for the use of this agency is completed at the "J" staff and MACV level of command.

(5) Armed Helicopters: The armed helicopters within each airmobile company, and those assigned to the armed helicopter company within the battalion give to the commander his greatest capability for immediate responsive close tactical air support. The tactics and techniques of employment are such that without fail a single command from the command and control helicopter can bring about devastating destruction of Viet Cong forces present within the landing zone. The techniques of suppressive fire developed by the armed helicopters allows preparation of the landing zone in a minimum amount of time with the capability to adjust quickly and accurately.

(6) Offensive Fire: A technique developed by the battalion utilizing all of its available armament resources to create a "wall of steel" covering known or suspected Viet Cong locations and at the same time sealing off and denying him the use of likely escape routes. Once the combat assault force has been airlanded into the landing zone the battalion may very well execute a simulated landing into a dummy LZ utilizing the technique of offensive fire. This method has proven very effective in the past and is an excellent means by which the ground commander can receive immediate close air support.

(7) Troop Landing Smoke Screen System: The use of chemical agents, (ie smoke, CS, CN) to prepare a landing zone is one of the most effective means against an enemy who is well entrenched around a proposed landing zone. The value of this system has been proven and its exact usage and criteria for delivery is contained in Annex N to the 145th Avn Bn SOP for Airmobile Operations.

(8) "MAD" (Mortar Aerial Delivery): The ability of an aerial platform to deliver projectiles into a landing zone which will have the same devastating effect as a mortar barrage has been a topic of study and discussion for a long time. Such a system, as unsophisticated as it may be, has been developed and proven with outstanding accuracy. The "MAD" system gives the ground commander the capability of aerial delivery of 81mm mortar rounds in any location he desires to prepare for the introduction of combat assault troops and provide close support there after. This system can be used in conjunction with any one of the above mentioned agencies for the preparation of landing zones. (Appendix I.)

(9) Preparation of Dummy Landing Zones: In order to deceive the enemy as to the exact location the combat assault landed force will be introduced, several landing zone locations may be prepared by Tac Air, Artillery or a combination of any one of the above agencies. This preparation must be planned and executed in the same manner as the actual landing zone to be used.

(10) Feint: During the conduct of an airmobile operation, whether combat assault or extraction, the use of dummy landing zones is very effective. Enroute to a landing zone the flight elements may descent to low level, a few feet above the ground, and give the impression that a landing is being conducted. By executing one or more of these maneuvers enroute to the objective area it is very difficult to ascertain the exact point of touchdown for off loading. However, it is imperative that prior to such a maneuver a thorough reconnaissance be conducted in the areas to be used as feints. All descents and climbs must simulate those of the actual area to be used for the combat assault.

Appendix

1. Mortar Aerial Delivery System

JOOST
Lt Col

OFFICIAL

Sauers
SAUERS
S-3

HQs 145th Avn Bn
Bien Hoa, RVN
15 April 1966

Appendix 1 (Mortar Aerial Delivery) to Annex P (Landing Zone Preparation)
to 145th Avn Bn SOP for Airmobile Operations

1. Purpose: The purpose of this SOP is to establish procedures and furnish guide lines for the tactical employment and aerial delivery of 81 mm mortars.

2. General: The "MAD", (Mortar Aerial Delivery) weapons system has the capability of augmenting existing methods of landing zone preparation, conduct of offensive fires, and is an excellent weapons system to be employed against prepared positions and concentrations of enemy personnel. It is a highly versatile weapon, which, when effectively employed, can deliver rapid, devastating, accurate ordnance on likely areas of retreat, avenues of approach, or supplement harrassing and interdiction fires in conjunction with ground operations.

The "MAD" system in no way duplicates or parallels the prestrike, or landing zone preparation and close air support mission of the USAF Tactical Air. This system is designed to provide the ground commander with a rapid limited ordnance delivery capability in support of combat personnel engaged with the enemy.

3. Ordnance:

a. 81mm Mortar: The standard 81mm mortar round, high explosive, is normally delivered with this system. The selection of different type explosive ordnance will be dictated by the mission and the requirement of the supported ground commander. To prepare the round for aerial delivery, the propellant increments, base fuze and point detonating fuze must be removed.

b. Fuze Nose Bomb, M-158: The M-158 fuze is utilized to provide safety features in flight and to arm the warhead after its release from the aircraft.

c. Assembly and Storage: The M-158 fuze replaces the point detonating fuze and will provide arming and detonation of the mortar round. The fuze should be hand tightened to the mortar round prior to delivery. A five foot strip of engineer tape is secured to the tail fins and wrapped so that it unfurls freely when the round is released from the aircraft. The engineer tape is required to provide stabilization during free fall and to insure the round strikes the ground nose first. Misfires will result if the tape is not used. After the assembly of component parts, the rounds will be stored, tail fin down, in a wooden box. A basic load of mortar rounds, fuzed, boxed and prepared for flight should be readily available for aerial delivery in the event a tactical situation arises requiring the use of this ordnance. Additional rounds should be available with the base fuze, propellant increments and the point detonating fuze removed. Care must be exercised to keep from bending or breaking the arming propeller during handling and storage.

d. Mortar Round Racks and Preparation for Delivery: A locally fabricated delivery chute is used to hold and release the rounds. The chute is wooden; dimension 50" by 19" with a sheet metal or tin cover on the bottom to allow the mortar rounds to slide freely. The rounds are loaded laterally, approximately 20 to a chute. Two chutes are utilized, one on either side of a UH-1D helicopter. Additional boxes of prepared mortar rounds may be carried inside the aircraft for reloading in the air. Prior to drop, a release door is opened and the rounds are held by hand to keep them from sliding out. At the command from the aircraft commander, the end of the chute is raised and the number of rounds required are allowed to slide out. Prior to delivery or enroute to the objective area, the safety wire on the nose fuze will be removed and the propeller hand turned one or two revolutions to insure freedom of movement. Approximately 150 revolutions of the propeller arms the fuze.

e. Aerial Delivery: The flight path of the aircraft will be determined by the geographical orientation of the target area or by the disposition and location of friendly units in the proximity of the strike zone. Flight paths will vary depending upon the tactical situation. Flight altitudes and speeds may be varied; however, more practice is required to obtain accuracy when other than the following recommended flight altitude and speed is used. At a flight altitude of 2500' feet absolute and an airspeed of 60 knots, the rounds are released when the aircraft's foot pedal attaching bolt is aligned with the target. The aircraft commander gives the command to release the rounds. Sensing the mortar rounds as they detonate, adjustments for target sight picture and wind conditions can be made and greater accuracy will result. To activate the fuze once it has become armed, five pounds of pressure is required. Excellent results have been obtained when this weapons system is employed against targets located in dense jungle areas where secondary forest canopies are prevalent. A variety of targets may be engaged with accuracy and the tactical employment of this weapons system is unlimited.

4. Safety:

a. Storage: A storage area or ammunition bunker will be prepared and sandbagged on the sides and top. Two compartments, separated by a sandbag wall will separate the basic load of mortar rounds and extra fuzes from the prepared ordnance. Signs indicating explosive material and no smoking within 50 feet will be displayed on all four sides of the ammunition bunker. A raised wooden floor with adequate spacing between floor boards is required for drainage and proper ventilation.

b. Handling: The basic load of ordnance must be stored in wooden boxes to allow for ease of handling and loading. The arming propeller must be turned over 150 revolutions to arm the round; however, care must be exercised to insure that the ordnance is not dropped or thrown. Miss fires will result if the fuze is bent or damaged.

c. Unexpended Ordnance: Upon landing, fuses of unexpended rounds will be safetied and tagged to indicate prior preparation. Proper planning must be exercised to prepare the exact number of rounds commensurate with the mission.

d. Defective Ordnance: Suspected defective mortar rounds or fuzes will be turned in to ordnance disposal personnel for destruction.

1 Incl:

2 Illustrations, side view and top view of delivery chute

OFFICIAL:

SAUERS
S-3

Inclosure 1 to Appendix 1 to Annex I to SOP ,145th Aviation Bn

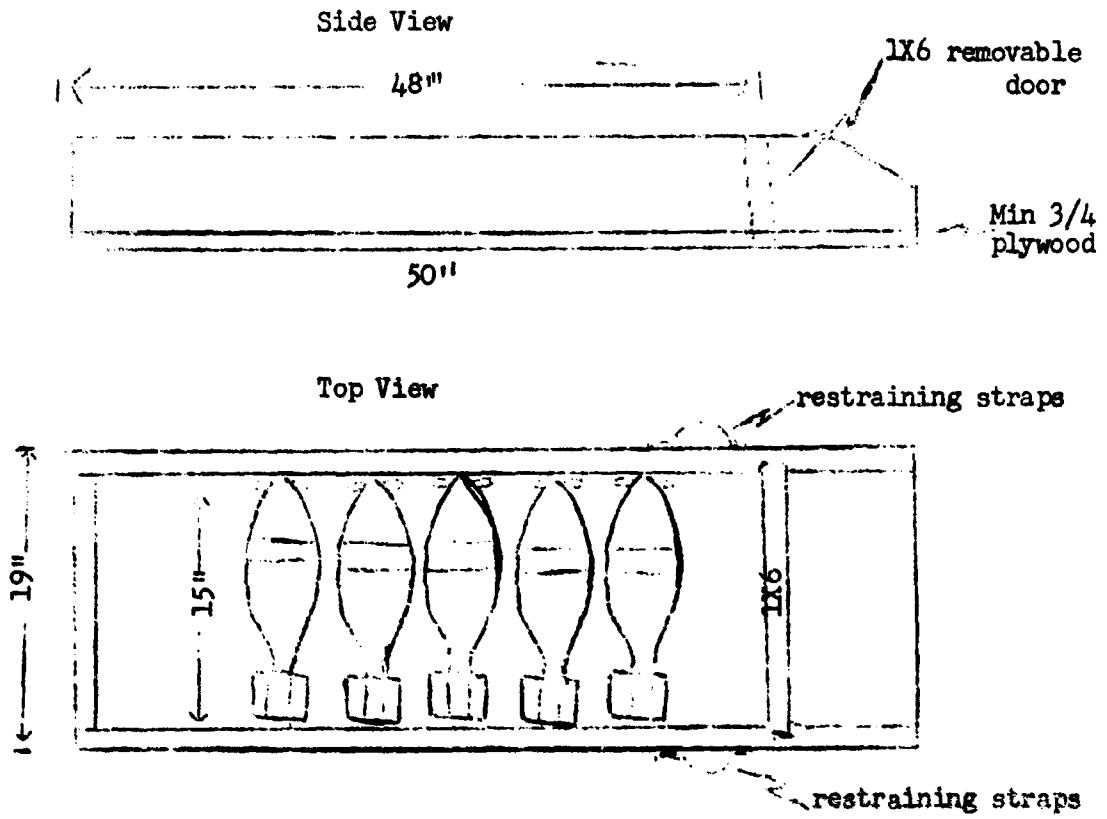

ANNEX Q (Night Airmobile Operations) to 145th Aviation Battalion SOP
for Airmobile Operations

1. Purpose: To establish procedures to be utilized by the units of this battalion during the conduct of Night Airmobile Operations.

2. General:

a. In order to adequately support the ground commander in all phases of his ground tactical plan, it is necessary that the aviation battalion be readily capable of immediate support during any hour of the day. To insure that this support is always present, it is necessary to establish criteria for the conduct of airmobile operations during the hours of darkness as well as daylight. Many of the procedures for the conduct of night airmobile operations parallel those practiced between the hours of BMNT and EENT, however, a different technique is involved.

b. The items which will require more attention to detail include:

- (1) Standard Night Formations
- (2) Aircraft Lighting
- (3) Landing Zone Identification Technique
- (4) Staging Area, Landing Zone and Extraction Site Markings
- (5) Flight Path Vector Techniques
- (6) Communication Procedures

3. Standard Night Formations: Variations of the standard formations, as illustrated, may be employed by the air mission commander as necessary to adjust to the tactical situation. Separation between helicopters will be a minimum of 100 feet from the extremity of one helicopter to another. The basic helicopter formations used by the battalion for night airmobile operations are as follows:

- a. Basic Symbols (Appendix 1)
- b. Company Staggered Trail (Appendix 2)
- c. Company Column, Flight in V's of Three (Appendix 3)

4. Aircraft Lighting: In order to utilize the cover of darkness to mask the battalion move from one location to another, a minimum amount of lighting is desired on the helicopter. The following action is taken on each helicopter prior to participating in night airmobile operations.

Insure that:

- a. All lower position lights and navigation lights are taped.
- b. Upper navigation lights completely taped and upper position lights taped in such a manner that the inside portion of the light can be seen only from above.

- c. The lower half of the tail light is taped.
- d. Landing lights and search lights are pre-set in case of emergencies.
- e. Minimum cabin lights are used.
- f. Position lights are placed in the "Steady-Dim" position.
- g. Grimes light (Rotating Beacon) is off at all times, except when a change in flight formation is desired. At that time, the lead aircraft of each flight element will illuminate the rotating beacon.

5. Landing Zone Identification Techniques: Two primary means are used for identifying the landing zone at night. The armed helicopter company, organic to the battalion, is responsible for the pre-strike and marking of all landing zones during a battalion size combat assault. During the prestrike, instead of using smoke to mark the touch-down point of the lead aircraft of the first flight element, a candle flare may be dropped at low altitude to mark the location of the most forward element. Secondly, night LZ illumination can be provided through the use of flares. On all battalion operations an Ol-F aircraft is airborne to act as radio relay, weather advisory and flare ship. Should the weather conditions and tactical situation dictate, the use of flares is most desirable. The battalion command and control helicopter will dictate their usage. If the landing zone has been pre-struck in such a manner that several obstacles are within the landing area, it may be advantageous for the helicopter of the first flight element to use its landing light. This is not recommended, as it provides a pin point target for the enemy around the LZ.

6. Staging Area, Landing Zone and Extraction Site Marking:

a. Staging Area:

In executing a night airmobile operation the 145th Aviation Battalion will stage from an improved landing strip or location, normally the Snakepit. This location will be marked in the following manner.

- (1) The four corners of the area will be marked with blue "bean bag" lights.
- (2) The touch down point of the lead aircraft of first flight element will be indicated with a "T" utilizing five amber lights.
- (3) The "T" will be relocated to indicate the touchdown point of the lead aircraft of subsequent elements.

b. Landing Zone:

(1) The lead flight element in a night airmobile assault will locate the landing zone either by reference to the prestrike conducted by the armed helicopters or request that flares be dropped from the overhead fixed wing aircraft acting as a radio relay and vector platform.

(2) The pathfinder team will accompany the lead flight element into the landing zone and guide subsequent element into the landing zone by the use of lights, strobe-light, navigational beacons or radios. The standard "T" will mark the touchdown point of the lead helicopter.

c. Extractions: For night extractions, the pathfinder team will precede the first flight element into the pick-up site by at least 30 minutes. The following tasks will be performed prior to touchdown time.

(1) The outer limits of the extraction site will be marked with blue lights. (Appendix 4)

(2) A "T" utilizing ten yellow and white lights will be placed just forward of the intended touchdown point of the lead helicopter. (Appendix 4)

(3) All obstructions within the boundaries of the extraction site will either be removed or marked with red obstacle lights. (Appendix 4)

(4) Positive radio communication will be established with the lead flight element at the release point (RP).

7. Flight Path Vector Techniques: Under conditions of reduced visibility or inclement weather, it is necessary to provide some type of vector means for the lead flight element to insure that the proper flight path is followed inbound to the landing zone. This can be accomplished through the use of one of three methods.

a. Vector Control Aircraft: The same aircraft used for radio relay and flare drop may also provide vector information to the lead helicopter.

b. Radar: If the landing zone to be used is within a 25 nautical mile radius of Saigon, through prior arrangements, Saigon Radar will vector the entire flight directly to the landing zone. The lead helicopter must have a fully functional IFF (Identification Friend or Foe) Transponder on board.

c. Decca Navigational System: The lead helicopter of each flight element will contain a fully functional Decca Navigational System. Proper map coverage can be placed in the system prior to the operation, and a preplotted flight path will lead the battalion directly to the landing zone. NOTE: "Night Effect" on the system will cause some inaccuracy depending on the atmospheric conditions.

8. Communication Procedures: Primary communications between flight elements and the battalion command and control helicopter will be UHF. Communications among the aircraft of each flight element will be company VHF and FM frequencies. All communications between the flight elements and pathfinder will be on FM. Standing Operation Instructions (SOI) and signal annexes for each operation will dictate primary means of communications.

ACKNOWLEDGE:

JOOST
Lt Col

4 Annexes
as

OFFICIAL:

J. Sauers
Sauers

3-3

241

Appendix 1 (Basic Symbols) to Annex Q (Night Airmobile Operations) to
145th Aviation Battalion SOP for Airmobile Operations.

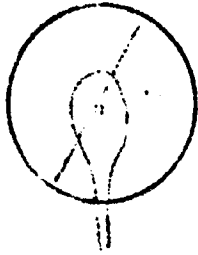

Troop Carrier

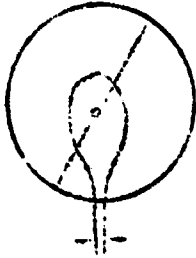

Flight Leader

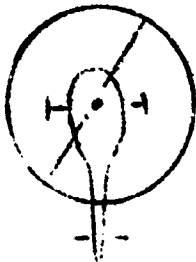

Armed Helicopter

C. J. SAUERS
SAUERS

S-3

Appendix 2 (Company Staggered Trail-Left) to Annex Q (Night Airmobile Operations) to 145th Aviation Battalion SOP for Airmobile Operations

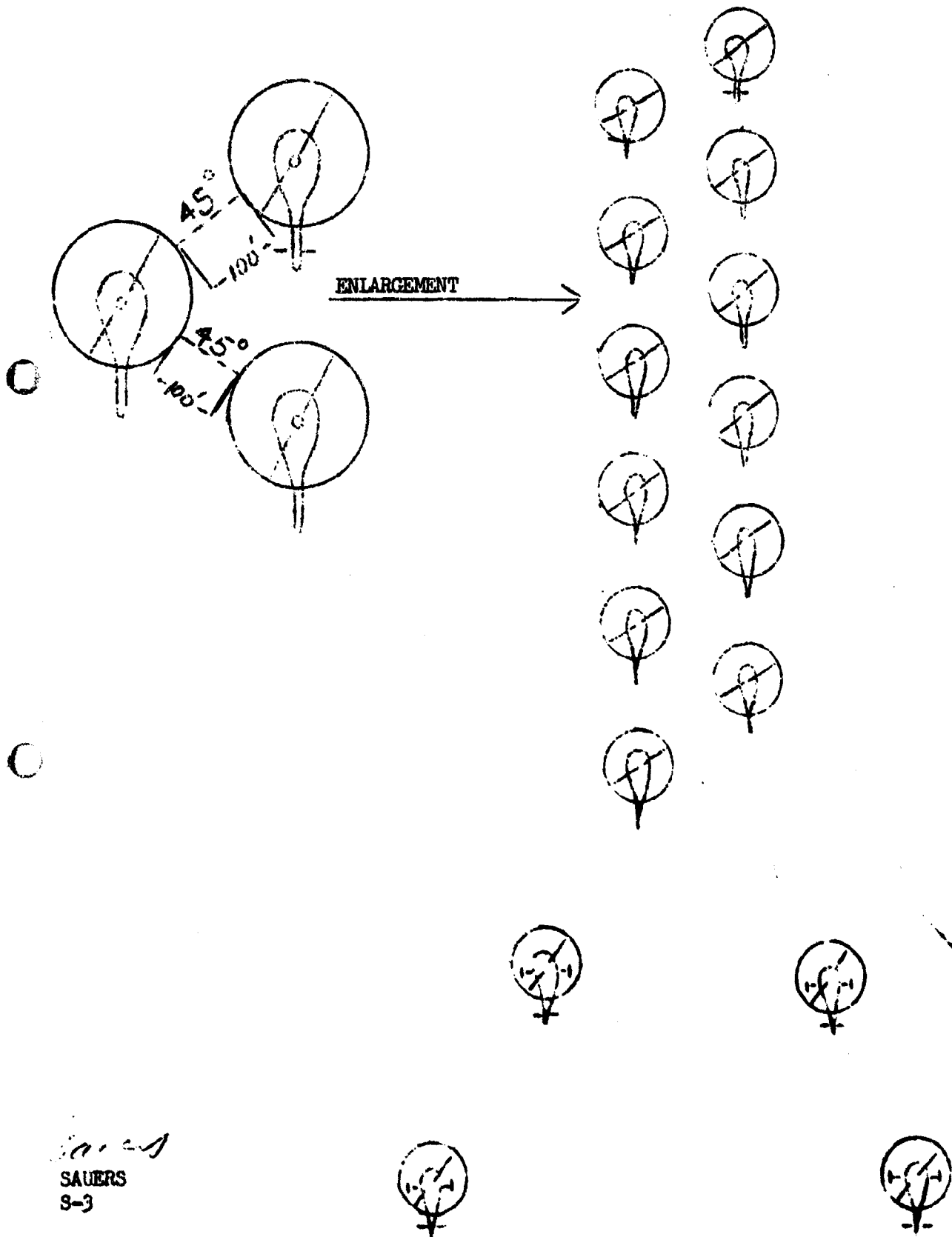

SAUERS
S-3

243

Appendix 3 (Company Column, Flight in V's of Three) to Annex Q (Night Airmobile Operations) to 145th Aviation Battalion SOP for Airmobile Operations.

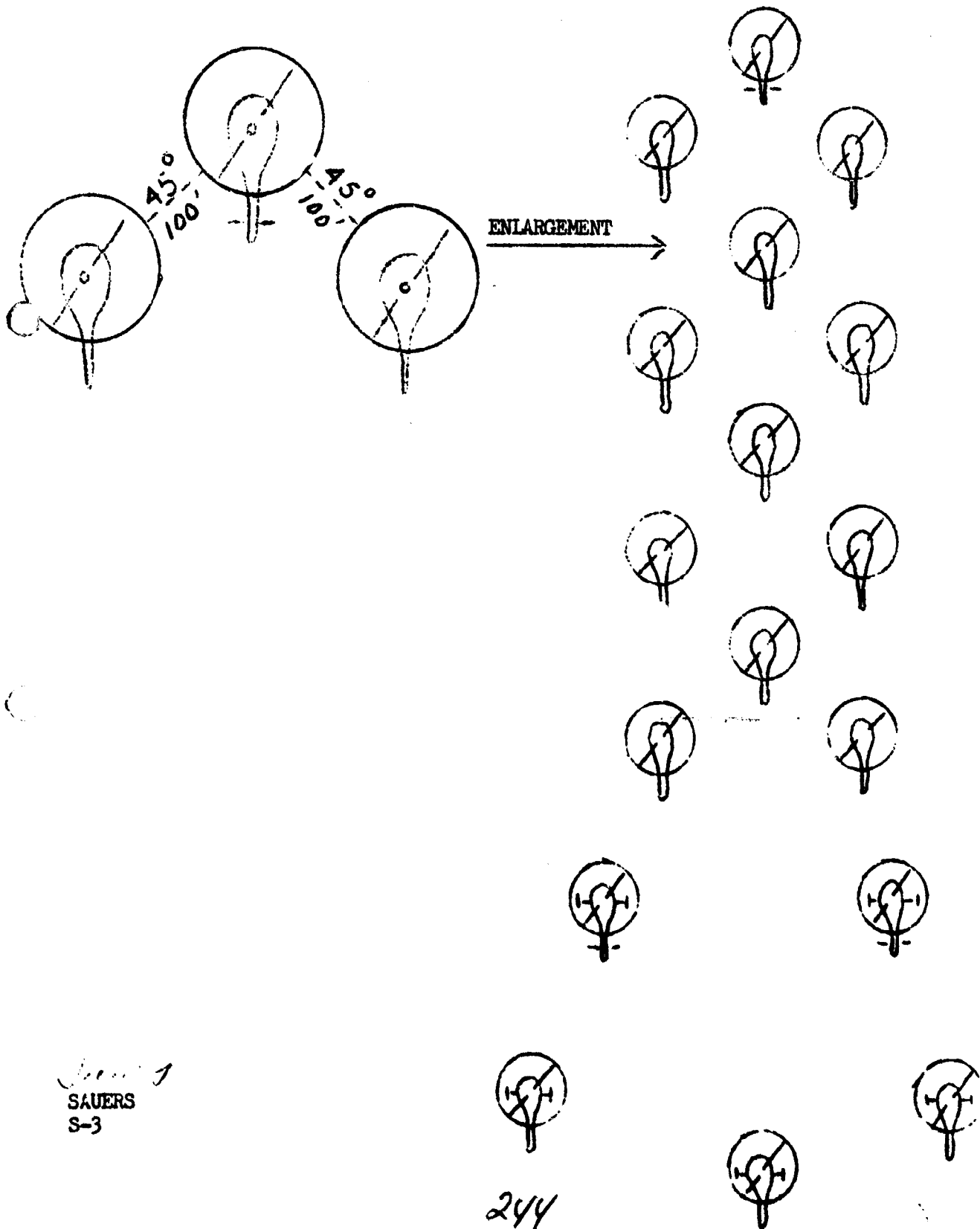

J. J. J.
SAUERS
S-3

244

Appendix 4 (Extraction Site Lighting) to Annex Q (Night Airmobile Operations)
to 145th Avn Bn SOP for Airmobile Operations

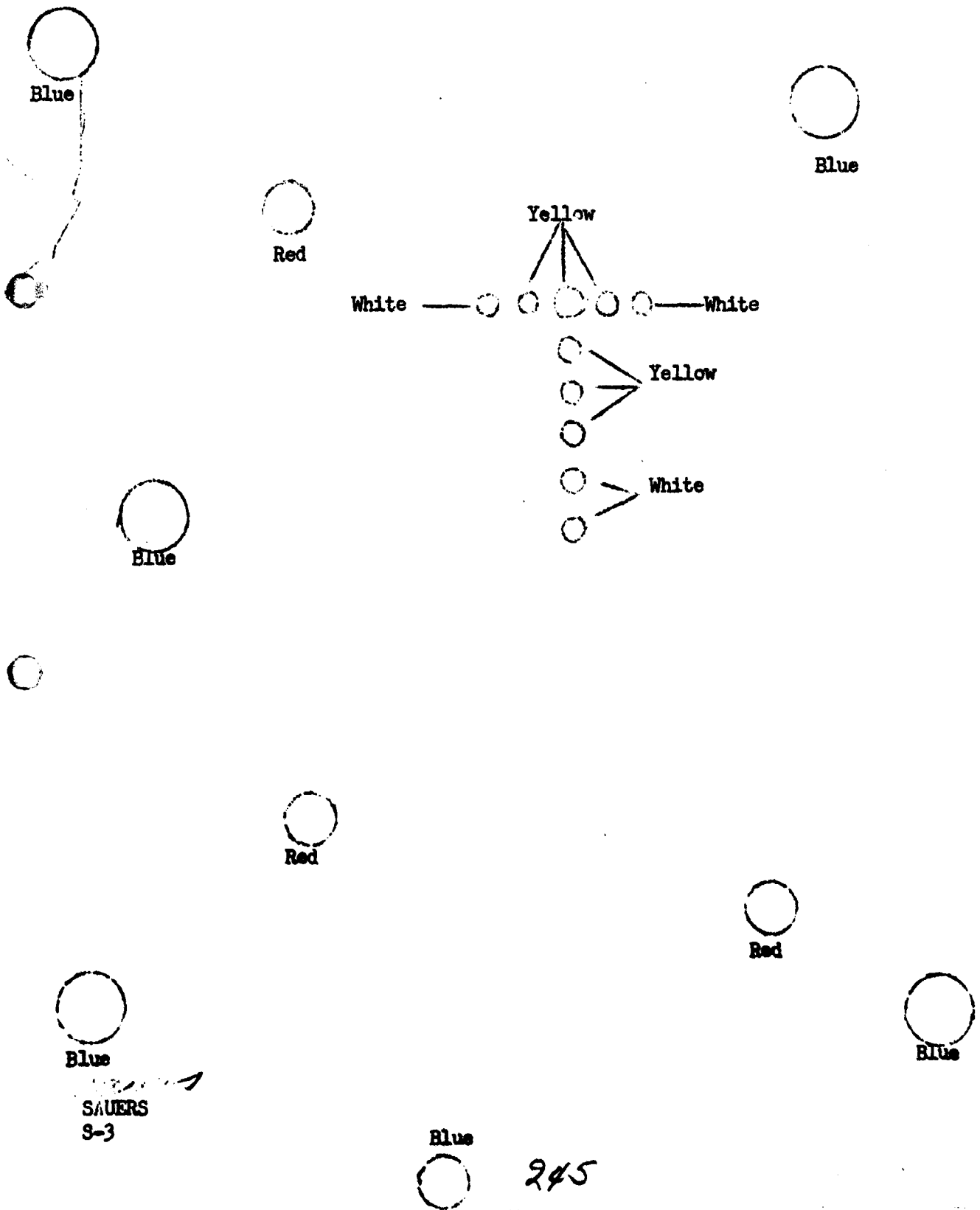

Hqs, 145th Avn Bn
Bien Hoa, RVN
15 April 1966

Annex Z (Distribution) to 145th Aviation Battalion Airmobile SOP

2 each unit, 145th Avn Bn
3 II Field Forces V
3 Aviation Brigade
3 12th Aviation Group
3 17th Aviation Group
2 1st (US) Infantry Division
2 25th (US) Infantry Division
2 173rd (US) Airborne Brigade
5 Deputy Senior Advisor III Corps
1 USARV Aviation Officer
1 USARPAC Aviation Officer

Acknowledge:

JOOST
Lt Col

OFFICIAL:

SAUERS
S-3

HEADQUARTERS
145TH AVIATION BATTALION
APO San Francisco, 96307

AVAN-F

23 February 1966

SUBJECT: Commanders Combat Note No 1

TO: See Distribution

I am proud to have been designated to command the 145th Aviation Battalion. This organization has distinguished itself on many occasions. It enjoys an esteemed reputation and has set the pace for other similar units arriving in Vietnam.

I intend to maintain this high state of professionalism while being cognizant that we are all first and foremost ground combat qualified and then are qualified to provide aviation combat support.

Army Aviation has changed the course of this conflict from a ground bound, ambush-susceptible slugging match, to a highly mobile and flexible posture that has been instrumental in keeping the Viet Cong off-balance. Army Aviation is providing the Free World Forces an offensive capability which is confronting the Viet Cong with an unpredictable nemesis. You are writing this chapter in history.

We must be mindful however, that our enemy carefully studies our every move and attempts to predict our pattern so that he can strike our weak spot. We must not be complacent with our past successes. We must constantly strive to improve our techniques and procedures. We must also be efficient with our resources of manpower and materiel. A non-combat loss of personnel and aircraft through an accident is a score for our enemy.

This battalion is an integrated team. Although basically the slick helicopter crew is the "bread and butter" of our many tasks, they are supported by everyone that makes up the organization. This includes the gunships, which provide protective fires, to the maintenance, avionics, operations, mail clerks, cooks, and all others that make the team. The success of each operation is the result of a contribution from each team member. Always bear this in mind!

Keeping everyone in this battalion informed is one of my goals. To this end, I will periodically publish a Commander's Combat Note which is intended to be disseminated to all members of this organization.

CLEAR LEFT AND RIGHT

Horst K. Joost

HORST K. JOOST
Lt Colonel, Inf
Commanding

DISTRIBUTION
"A" Plus
5-Each Company
Info: 10 - 12th Avn Group

247

HEADQUARTERS
145TH AVIATION BATTALION
APO San Francisco, 96227

AVAW-F

28 February 1966

SUBJECT: Commander's Combat Note #2

TO: See Distribution

1. Effective immediately I desire that the word "SCRAMBLE" be stricken from usage in the 145th Aviation Battalion and that it be replaced by "REACTION".

2. The word and the connotation of "SCRAMBLE" implies that Haste is of primary importance and that safe practices and procedures are relegated to second place. This should never occur.

3. Another implication of the word "SCRAMBLE" is that it is licence for a careless and slipshod operation, disregard for regulations, and actions based on emotion rather than sound judgement.

4. In all our missions we must have a sense of urgency. However, this sense of urgency must be tempered by a deliberate and calculated "REACTION" to the immediate situation and never be overshadowed by unsafe practices or procedures.

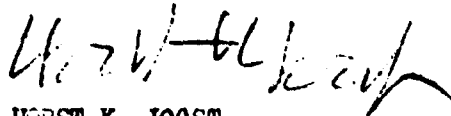

HORST K. JOOST
Lt Colonel, Inf
Commanding

DISTRIBUTION

"A" Plus
5 to each Company
10 - 12th Avn Group

HEADQUARTERS
145TH AVIATION BATTALION
APO San Francisco, 96227

AVAW-F

3 March 1966

SUBJECT: Commander's Combat Note #3

TO: See Distribution

WEARING OF DECORATIONS AND AWARDS

US Army Aviation is world renown for its mental alertness and sharp military appearance. Whether in the field or on parade we take a back seat to no one; indeed, Army Aviation is "Above All". We have established ourselves as the military pioneers of our modern day Army and in the case of this particular Battalion, we have "written the book" on airmobile warfare in Vietnam.

It is every soldier's duty to uphold this reputation and reaffirm it whenever the opportunity arises. Wear your uniform properly and proudly. It is made of fine material and represents the finest nation in the world. Wear all badges and decorations properly. You have earned them and they represent some of your accomplishments.

Since it would be impractical for each member of the Battalion to seek out the appropriate regulation to insure that he is wearing his badges and ribbons in the proper order, this note is published so that our soldiers, when they wear their decorations here or proceed to their next assignment, will arrive with their decorations worn in the proper order.

"FIRST IN VIETNAM"

1 Incl
Chart of Awards

Horst K. Joost
HORST K. JOOST
Lt Colonel, Inf
Commanding

DISTRIBUTION
4 Plus
5 to each Company
INFO: 10 - 12th Avn Group

249

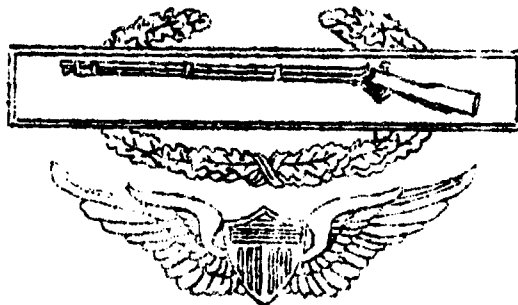

	Medal of Honor	Distinguished Flying Cross	Distinguished Service Medal	
*Silver Star	Legion of Merit	Distinguished Flying Cross	Soldiers Medal	Bronze Star
Air Medal	Joint Services Commendation Medal	Arm Commendation Medal	Purple Heart	Good Conduct Medal
American Defense Service Medal	American Campaign Medal	Asiatic Pacific Campaign Medal	European, Africa, Mi Eastern Campaign Medal	World War II Victory Medal
Army of Occupation Medal	National Defense Service Medal	Korean Service Medal	Armed Forces Expeditionary Medal	Vietnamese Service Medal
Armed Forces Reserve Medal	Philippine Service Ribbons	Foreign Decorations	United Nations Service Medal	Other Foreign Service Medal

*Ribbons may be worn on bars of three, four or five



----- Worn on pocket if CIB and aviators wings are worn.

NOTES:

1. The Distinguished Unit Emblem is worn centered immediately above the right breast pocket.
2. The Republic of Korea Presidential Unit Citation, with the red portion uppermost, is worn immediately above the right breast pocket. If the Distinguished Unit Emblem is worn at the same time, the ROKPUC will be worn closest to the center of the wearers body.
3. United States Medals are worn in the order earned.
4. The order of precedence is always from left to right as you face the wearer.
5. Cross of Gallantry if awarded as an individual award will be worn in the block "Foreign Decorations".
6. All personnel of this battalion are authorized to wear the Vietnamese Cross of Gallantry (as a unit award) over the right pocket.

HEADQUARTERS
145TH AVIATION BATTALION
APO San Francisco, 96227

AVAW-F

4 March 1966

SUBJECT: Commander's Combat Note No #4

TO: See Distribution

ENEMY ACTIVITIES AGAINST HELICOPTERS

1. CAPTURED VC DOCUMENTS ON ANTI-HELIBORNE TACTICS. Recent captured documents verify that the VC are studying our heliborne operations closely and are training to take the best defensive measures against us. Following are excerpts from several captured documents. The contents are quoted here to keep you informed of VC anti-heliborne tactics and to remind each of us that we must continue to be flexible in our planning and execution of our missions.

a. Anti-Aircraft Organization. In each village, hamlet or crowded market, the VC set up an air warning post run by specialized personnel or the inhabitants who watch on a rotation basis. When the aircraft arrives, the post occupants beat a triangular iron, drum or tocan to warn the VC.

b. Aircraft Downing Organization. If the condition permits, each village will organize many aircraft downing cells of 3-4 men each. Sharpshooters are selected from village guerrilla units and will be trained on techniques of downing aircraft, using organic weapons. In case of emergency, those who have weapons can fire, but are not to fire at random to keep troop locations from being discovered.

c. Counter-Heliborne Operations. In hamlets and villages or areas having open and dry fields suitable to air drops or heliborne landing are all covered with sharp spikes of 2-3 meters high, mines and booby traps. In addition, fortifications are set up around this area. Therefore, when paratroopers and helicopters land, the VC will attack both paratroopers and the aircraft.

2. HIGHLIGHTS ON THE OPERATION IN NORTH BEN CAT. (Refers to 173rd Abn Bde in October 1965).

a. Before the operation, the US conducted air reconnaissance on several occasions and during many days in advance in order to observe the terrain, prepare and determine the operation plan.

b. The Air Force and Artillery went into action 2 or more days before the operation started. B-52 bombers were even employed to soften the area from 30 minutes to 1 hour before the operation started.

c. Helicopters were employed to land troops on one or more LZs from where attacks were launched in several directions. Some guerrilla cells grasped the U.S activity schedule (depart from the landing zone in the morning, return in the evening to change clothes, draw sleeping bags, and rations supplied by helicopters) and approached US bivouacs every night to attack them with hand grenades, thus inflicting losses upon them constantly harrassing and frightening them.

d. Thirty to forty minutes after the bombing of an area, (by B-52s) enemy helicopters would land about 2 companies to one battalion. Lacking preparations to attack enemy heliborne troops or having inadequate preparation, failing to be determined against the enemy and being afraid of enemy fighters, Quyet Thang unit missed 2 opportunities to wipe out a few enemy companies.

3. CHARACTERISTICS, CAPABILITIES AND EFFECTS OF D.H. 10 MINE (Directional Mine)

a. The P.H. 10 Mine is a type of mine which launches its fragments in a fixed direction and is very effective in wearing down and annihilating the enemy infantry and his armored vehicles less than 3 MM thick. It is also efficient in destroying and exterminating landing helicopters, in neutralizing the runway and the landing zones as well.

b. Description. It is 30 CM in height. It looks like a big compass. Its container is made of tin. Its concave surface contains 420 to 450 steel fragments. Resembling a cylinder, each fragment is 12MM in diameter and 12 MM in height. In its center of gravity, there is a hole in which an electrical blasting device with a resistance of 4 ohms is plugged in. In combat usage this mine is mounted on its quadruped. Its concave surface and its axis are aimed through its sight directly at the target. When the mine is exploded its fragments scatter. If the range is 200M, fragments will be scattered within a circle of 16 to 20 meters. If the range is 50 meters, the fragments will be scattered within a circumference of 4 to 5 m in diameter. In each square meter of this surface, there are 5 fragments per average. This mine can be laid in the open field with its concave face turning upward to prevent enemy choppers and paratroopers. In this case as well as in the case of setting mines in the friendly defense perimeter of the battle ground for counter operations, the electrical wire must be buried deep in the earth to prevent being cut by enemy airstrikes and artillery shells.

"FIRST IN VIETNAM"

Horst Joost

HORST K. JOOST
Lt Colonel, Inf
Commanding

DISTRIBUTION

"A" Plus

5 to each company

INFO: 10-12th Avn Group

252

AVAW-FB

TRANSLATION REPORT

4 March 1966

SUBJECT: Commanders Combat Notes No 5

TO: See Distribution

1. The following is taken from USMACV DEC Log No 02-1090-66, Subject: Translation Report c. Enemy Documents, for your information.

-----FULL TRANSLATION-----

Page 1 of original text

Grenade Launching Holes Against Helicopters, Infantry and Vehicles.

I. Characteristics.

These holes are used against:

- a. Helicopters landing on fields and clearings.
- b. Enemy infantry and vehicles during their sweep operations on rough terrain and clearings.

II. Form and Size of the Grenade Launching Holes.

- a. 60cm in diameter.
- b. 60cm in depth.
- c. Having the form of a funnel.

III. Equipment Needed.

- a. A square board, 5cm in thickness and 60cm on each side
- b. A 1.400 kg TNT pack.
- c. Detonator Nr 8, electric detonator.

IV. Deployment Against Helicopters.

a. Selection of Position:

- Select open spaces where helicopters can land so that grenades will not encounter any obstacles once launched.

- Make several holes in an area to concentrate the fire power of grenades in order to down the helicopters.

- Dig holes in the form of a triangle or parallelogram.

b. Method of Making:

1. Dig a round hole, 60cm both in diameter and in depth having a funnel like shape (similar to a upside-down latrine conical hat).

2. Put the TNT pack in the hole and place the electric wire in the hole.

3. Fill the hole with dirt up to 10cm from the board.
4. Lay from 10 to 16 grenades on the board then pull out the safety pins.
5. Link the electric wire from the hole to the place of the man who will blow the mine, from 200 to 300 meters. It will not be broken when the RVNAF clear the landing field.

METHOD OF NAILING TO FASTEN GRENADES TO THE BOARD

a. MK2 Grenade.

Drive 2 nails at 7cm from each other to keep the grenade in place.

Lay grenades on the board between the nails.

Pull out the safety pin when the board has been put over the hole and grenades placed between the nails.

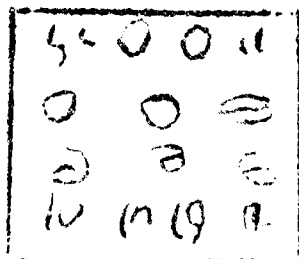

b. Stick Grenade (primer).

Nails must be driven in the board the same way as for MK2 grenades.

The wooden stick must protrude 1cm from the board.

Plant stakes 1.2 meter from the board and fasten the grenade sticks to the stake by wire. (When the mine explodes, grenades will be thrown upward and dispersed - They will explode in the air because their primers, tied to the wire, have been pulled out.)

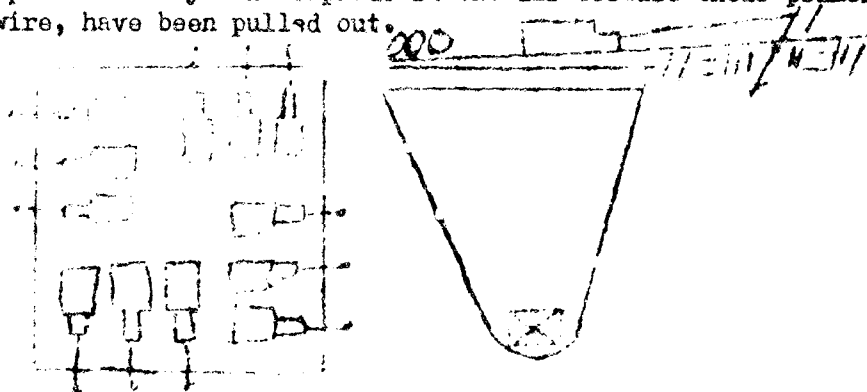

Camouflage.

Once everything is ready, cover the grenades and board with grass and dirt gathered from surrounding area. (This camouflage is similar to that for mines). During camouflage, one should pay attention not to cover the holes with too much grass and dirt and not to make the grenade spring up from the board.

c. Organization of the grenade-planting cell.

3 persons - One digs the hole and the other two fasten grenade sticks to the stake.

These men are provided security and warned by guerrillas or their comrades-in-arms.

3. Fill the hole with dirt up to 10cm from the board.

4. Lay from 10 to 16 grenades on the board then pull out the safety pins.

5. Link the electric wire from the hole to the place of the man who will blow the mine, from 200 to 300 meters. It will not be broken when the RVNAF clear the landing field.

METHOD OF NAILING TO FASTEN GRENADES TO THE BOARD

a. MK2 Grenade.

Drive 2 nails at 7cm from each other to keep the grenade in place.

Lay grenades on the board between the nails.

Pull out the safety pin when the board has been put over the hole and grenades placed between the nails.

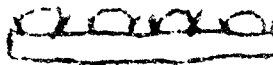
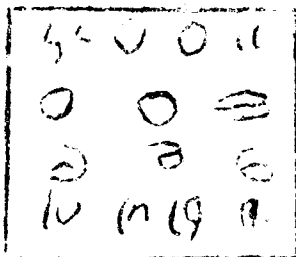

b. Stick Grenade (primer).

Nails must be driven in the board the same way as for MK2 grenades.

The wooden stick must protrude 1cm from the board.

Plant stake 1.2 meter from the board and fasten the grenade sticks to the stake by wire. (When the mine explodes, grenades will be thrown upward and dispersed - They will explode in the air because their primers, tied to the wire, have been pulled out.)

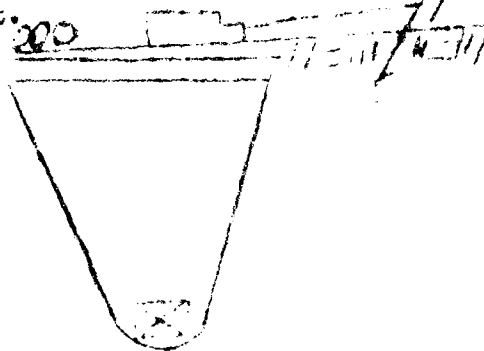
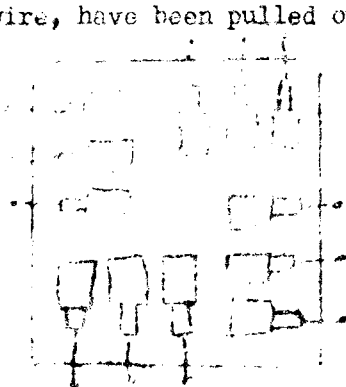

Camouflage.

Once everything is ready, cover the grenades and boards with grass and dirt gathered from surrounding area. (This camouflage is similar to that for mines). During camouflage, one should pay attention not to cover the holes with too much grass and dirt and not to make the grenade spring up from the board.

c. Organization of the grenade-planting cell.

3 persons - One digs the hole and the other two fasten grenade sticks to the stake.

These men are provided security and warned by guerrillas or their comrades-in-arms.

HEADQUARTERS
145TH AVIATION BATTALION
APO US Forces, 96227

AVAW-FB

4 March 1966

SUBJECT: Commanders Combat Notes No. 6

TO: See Distribution

1. Contained herein are extracts from translations of documents captured by units of the 173rd Airborne Brigade during "Operation Crimp". They lend some insight into the mental attitude, morale, and tactical doctrine of the men we are fighting.

2. Circumstance of capture: Unit: 1st Bn RAR/173rd Airborne Brigade
Date: 11 Jan 66 Area: XT 650280

FULL TRANSLATION

"For the past few days the enemy has been launching air and artillery action against our area, sowing destruction and confusion among the civilians and revolutionary forces. Recent information from high level disclose that the enemy will launch a sweep operation against the area bordering and the villages within our base area, as of 6 January 1966. This action will be launched by the Americans and puppet troops, the latter being the main force and the Americans the backbone.

H.151 hereby informs the various places of the above news. The following emergency measures must be taken tonight:

- 1/ Check countersweep positions, landing strips, trenches and fox-holes. Insure that continuous fighting can be performed.
- 2/ Deploy village guerrilla forces along countersweep positions respectively assigned to them and organize the civilian forces for on-the-spot political struggle and active military proselyting.
- 3/ Frequent liaison and reports to the predetermined places, such as agencies above and below Route 7, must be made.
- 4/ Check all grenades, mines, (booby traps) launching pads, planted grenades, and ammunition for fierce and continous countersweep action.

Upon receipt of this note, addressees must immediately carry our plans along the above mentioned lines but with specific measures appropriate to each local area. This must be done without delay tonight and secrecy must be insured to avoid sowing confusion among the civilians who might then evacuate the area: it would not benefit us."

3. Circumstance of capture: Unit: B/1/503
Date: 120700 Jan 66 Area: Xt 647297

"Have spent four days in tunnel. About 8 to 9 thousand American soldiers were in for a sweep-operation. The attack was fierce, in the last few days. A number of underground tunnels collapsed. Some (of our men) were caught in them and have not been able to get out yet. It is not known what have become of sisters BA, BA Y, HONG HANH and TAN HO in these tunnels. In their attempt to provide security

for the agency, TAM and UT were killed. Their bodies, left unattended and deteriorated, have not been buried yet. In the afternoon, one of our village unit members trying to stay close to the enemy for reconnaissance was killed and his body has not been recovered.

Fifteen minutes ago, enemy jets dropped bombs: houses collapsed and trees fell. I was talking when a rocket exploded 2 meters away and bombs poured down like a torrent.

We should fight them, we should annihilate them, you (US soldiers) will have no way out...

It is always dark before sunrise. After cold days, warm days will come...

The most tiresome moment is when one moves up a hill. One must rise up disregarding death and hardships, determined to defeat the American aggressors.

Oh! What hard days, one has to stay in tunnel, eat cold rice with salt, drink unboiled water! However, one is free and feels at ease.

4. Circumstances of capture: Unit: 2nd Bn/503, 173rd Abn Bde

Date: 11 Jan 66

Area: XT 657275

SUMMARY:

"The following are extracts from a notebook which was written in Chinese, no identification of writer or time period.

-The important targets have to be destroyed are: airport, ammunition storages, wharfs, fire-arms and cars concentrated places, important American Offices, ministry of National Defense etc...

-The men have to be killed are: American officers, soldiers and technicians, the MPs, High Vietnamese personnel, US Messes and camps etc...

Every time when the enemy is careless, we must attack them immediately so we have to prepare weapons and always make plans in mind.

-A good example (how to kill enemies) in 1953, the Viet Minh made fire on the French ammunition storage, hundreds of French were putting out the fire. A bomb exploded and killed them all. (Enemies had double casualties).

-Steal the enemies' weapons to kill them.

-Use strong poison needles to kill Americans who walk alone in the street.

-Find a place to hide grenades all around the target which we plan to destroy. (Avoid danger of transportation.)

-How to keep secret about organization systems? Do not say anything to parents, friends and relatives.

-Make secret signals to comrades.

-Learn by heart all streets especially small streets around the house and the district you live in.

-When walking in the street with weapons, send a comrade to go before you to see if there is any policeman.

SUBJECT: Commanders Combat Notes No. 6

-In the street or in a crowd, don't say hello to any comrades you meet.

-Always pay attention to see if there is someone following you, from time to time bend down to fasten your shoe-laces or look at the shop-windows, "Keep secret about the activities".

-Don't tell the whole plan to your comrades, only to those who are in charge of work.

-First, prepare a secret place to store fire-arms, then a safe but secret place for comrades to take shelter.

-Second, make clear the secret signals of advancing, fighting and retreating.

-Disguise the important documents carried on you so that even the enemies can't find them.

-Never use real names: For things, replace by other words such as: fish in water means enemy ships, sparrow means aircrafts, crabs mean cars.

There are many other ways to teach comrades to dupe the enemy."

5. Circumstances of capture: Unit: 2nd Bn/503, 173rd Avn Bde
Date: 11 Jan 66 Area: XT 657275

FULL TRANSLATION

SUMMARY:

"Personal letter, written in Chinese, containing the following main points:

-A youth, he did not want to be drafted. So under the introduction of his friend, Mr. Wong, he was led by him into the Liberated Area to become a member of VC.

-Luther: Chinese named Ming-Chiang possibly Middle-High-School education perhaps lived in Cholon written on 7 May 65 in Liberated Area.

-The last paragraph "...we must bear all the hardship to win over the American imperialist."

"FIRST IN VIETNAM"

Horst K. Joost
HORST K. JOOST
Lt Col Inf
Commanding

DISTRIBUTION:

"A" Plus
5 to each company
Info: 10-12th Avn Group

HEADQUARTERS
145TH AVIATION BATTALION
APO San Francisco, 96227

AVAW-F

5 March 1966

SUBJECT: Commander's Combat Note #7

TO: See Distribution

SUMMARY OF OPERATIONS 21 FEBRUARY THROUGH 3 MARCH 1966

1. During this period the 145th Aviation Battalion, in addition to moving to Bien Hoa, conducted nine major airmobile operations, two of which were conducted in one day. Our armed helicopters operating at night, accounted for 18 sampans or boats sunk, one of which was carrying VC troops and explosives, 15 sampans were damaged, and 5 VC huts were destroyed. On 23 February, armed helicopters of the 197th Aviation Company were responsible for the VC withdrawal from an attack on an ARVN compound when they brought fire to bear on the attackers.

2. This battalion supported the 2d Brigade, 1st U. S. Infantry Division, on 21 February, during Operation MASTIFF, by conducting six combat assaults with three infantry battalions, into two landing zones, 15 Kilometers southeast of Dau Tieng. Forty-four troop carriers and 32 gunships were employed. Enemy small arms and automatic weapons fire was received during the landings. Aircraft damage was slight. Suppressive fire from armed aircraft placed on enemy positions was responsible for decreasing the volume and intensity of VC fire.

3. On 22 February this battalion airlifted a regiment of the 10th ARVN Division from An Loc, vicinity of Xuan Loc, and conducted an airmobile assault 43 KM to the South, near Binh Gia. Thirty UH-1D's and 17 UH-1B's (armed) were employed in the operation. No air or artillery preparation of the LZ was used in order to achieve surprise during the landing, and to preclude the possibility of setting the dry grass which covered the LZ on fire. The gunships of the 197th Aviation Company led the way by a few minutes and placed accurate and deadly fire on the treeline which encircled the LZ. The initial assault was accomplished with no enemy fire on the LZ. The gunship preparation however, started the grass burning in the LZ. The smoke and fire became intense which necessitated the subsequent lifts to be diverted to an alternate LZ. The response on the part of all elements was immediate when modifications in plans were made from the battalion command and control aircraft. Gunships diverted to the new LZ and began to place fire on suspected areas. The troop carriers modified their formation while airborne to compensate for the new conditions on the LZ. Between lifts, Air Force tactical air placed strikes on enemy ground fire along the helicopter flight routes, which had begun to become active. This operation demonstrated the flexibility of airmobile operations by being able to adjust to changing conditions with a minimum amount of radio transmission from a single command element. It also demonstrated the team work inherent in the gunships, troop carriers, and Air Force Tactical air.

259

4. The 2d Brigade, 1st (US) Infantry Division was extracted from two landing zones by this battalion on 25 February, employing 31 UH-1D helicopters and 17 armed helicopters. These troops were lifted back to Dau Tieng prepared to be re-committed to another airmobile assault. Enemy small arms and automatic weapons fire was received by flight elements in the vicinity of the extraction zones. Three aircraft hits were sustained.

5. The morning of 26 February found this battalion assembling 20 troop carriers and 14 armed helicopters to airlift elements of the 25th ARVN Division and assault two landing zones located 15 KM Northeast of Ben Luc in order to conduct search and destroy operations against Viet Cong forces, supplies and installations. Ground fire was received and one aircraft hit.

6. At 1700 hours that evening, the battalion lifted elements of the 173rd Airborne Brigade into one landing zone into war zone D, 11 KM Northwest of Bien Hoa. This assault was designed to commit a reaction force into a blocking position to entrap a VC main force element, that was being engaged by the paratrooper elements previously lifted into the area. Enemy fire was received from numerous locations around the assault LZ as the troop helicopters landed. Two aircraft received damage. During the extraction one UH-1D troop carrier from the 118th Aviation Company experienced a flame out and was successfully landed without damage in a rice paddy in the vicinity of the operational area. A night recovery of the downed aircraft by a CH-47 helicopter was executed. This latter accomplishment demonstrated the teamwork that we have developed in accomplishing any mission.

7. Early in the morning of 28 February, a main force Viet Cong, estimated to be a regiment, attacked and overran the ARVN secured town of Vo Xu located east of Vo Dat in the Rice Bowl area. At 0455 hours the 145th Aviation Battalion was alerted to provide a rapid reaction airmobile capability to reinforce the friendly forces in Vo Xu. By 0630 hours, forty UH-1D troop carriers and 17 UH-1B armed aircraft were on runway alert at Bien Hoa, Vung Tau and Tan Son Nhut. All aircraft and crews were assembled, briefed and organized for combat by 1730 hours. One Ranger Battalion was airlifted from Duc Hoa and positioned at Vo Dat. Another was lifted from Bao Trai and positioned at Vo Dat. Another ARVN Ranger Battalion was then lifted from An Loc and an airmobile assault conducted south of Vo Xu. One of the Ranger Battalions positioned at Vo Dat next conducted an assault on the same LZ. These assaults were designed to entrap and intercept the VC that had attacked Bo Xu earlier in the day. Three aircraft were hit by enemy ground fire. During the assault, one troop carrier aircraft experienced a hard landing, and could not be flown out of the LZ. Immediate action was taken to prepare the aircraft for liftout. A CH-47 helicopter arrived and within seconds snatched the aircraft out of the LZ. This recovery was performed with such speed that it did not interfere with the tactical plan of the ground elements. This day's operation proved on several occasions that Army Aviation elements are more responsive to rapid reaction than are the ground elements. Planning for the conduct of the operation was accomplished in the cockpit by commanders and staff while flying to assembly areas. Short, standardized briefings and mission type orders are the key to rapid reaction.

8. On 1 March, 2/503 Inf Battalion, 173rd Airborne Brigade, was extracted from their operational area in War Zone D, to the Brigade base. Three lifts were conducted employing twenty-eight UH-1D and thirteen UH-1B (armed) helicopters. Hostile ground fire was encountered during the lift out.

9. In the early morning of 2 March, the battalion again assembled its elements for an airmobile assault. Thirty UH-1D troop carriers and eighteen

UH-1B armed helicopters were employed. This time elements of the 25th ARVN Division were lifted from Trang Bang and Cu Chi to assault three landing zones 11 KM South of Tay Ninh, adjacent to the Cambodian border. All three landing zones were prepared by tactical air strikes and armed helicopters, however, light to moderate automatic and semi-automatic enemy weapons fire was encountered. Gunships and tactical air was placed on this ground fire. One troop carrier was hit. During the airmobile assaults an air observer detected approximately 40 VC fleeing west toward the Cambodian border. Gunships gave chase and worked the area over with their weapons. Damage to the VC is unknown.

10. On the last day of the reporting period, 3 March, this battalion conducted an airmobile assault with elements of the 10th ARVN Division south of Baria, immediately adjacent to the sea coast. Twenty-seven UH-1D and 25 UH-1B armed helicopters were employed. Troop pick-up was from a road north of Baria. Four lifts completed the operation. Light to moderate hostile fire was encountered during the assault. Armed helicopters and tactical air strikes worked over these enemy locations during and between lifts. No aircraft hits were sustained.

11. In addition to these operations this battalion provided normal command and liaison, administrative and logistical support for III ARVN Corps.

12. A wrap-up for the period is as follows:

- A total of 5,547 U.S. and ARVN forces were committed in airmobile assaults. Extractions of forces from areas of operations consisted of 1,525 U.S. Forces. Repositioning of 639 ARVN troops was accomplished.

- The total sorties flown was 6,118 for a total of 2,192 flying hours.

13. This was a full period and all members of this battalion are to be congratulated for their accomplishments. Added congratulations must go to the maintenance personnel who have kept us ABOVE ALL.

14. In the area of civic action, which I feel is as vital as combat operations, this battalion is making great strides. In addition to our heavy operations schedule for the period, the 145th Aviation Battalion was active in the areas of Community Relations, Educations and Training, and Health and Sanitation. A total of \$VN 16,020 was collected by the 197th Aviation Company to purchase baby beds for a Saigon orphanage. Officers and enlisted men from A/501st Aviation Battalion conducted 4 one-hour English classes for the Bien Hoa National Police. Members of the 118th Aviation Company continued to provide support to a Bien Hoa orphanage in the form of 320 lbs rice, 100 lbs of peanuts, powdered milk, cooking oil, condiments and various cleaning products. In addition, two doctors visited the Leprosy colony for the purpose of treating patients. Letters received by members of the 68th Aviation Company indicate that local drives in their hometowns are making progress and donations for distribution to the local populace will be forthcoming.

"FIRST IN VIETNAM"



HORST K. JOOST
Lt Colonel, Inf
Commanding

DISTRIBUTION:

"A" plus
10 - 12th Avn Gp
5 - Bn CO
50 - S-1
100 - Ea Co

261

HEADQUARTERS
145TH AVIATION BATTALION
APO US Forces, 96227

AVAW-FB

11 March 1966

SUBJECT: Commanders Combat Notes No 8

TO: See Distribution

1. The handling of classified material is extremely important to the successful accomplishment of our mission. Almost every aviator comes in contact with classified material every day, and because of this daily routine it is easy to become complacent and forget its importance. This is especially true with SOIs and operational orders. An added hazard to our handling of classified material is that at times it must be used during flight. Open windows and doors of aircraft are an invitation to loose papers.

2. I want to emphasize very strongly the 145th Aviation Battalion policy that SOIs will be carried on the person. They will not be set down on the console while flying. The aviator who will be tuning the radios is the aviator who should have the SOI. Carrying SECRET documents in the aircraft is discouraged as much as possible. Only when operational requirements demand will SECRET documents be carried.

3. Another matter of security is voice communications over the telephone and especially over the radios. Attempting to double talk or talk around a subject to transmit a message is useless. If you can succeed in getting the message translated to whom you are talking you have also informed the VC listening in on your conversation. We know for a fact the VC monitor our UHF and FM radios. We have brevity codes, map coordinate codes, and call sign codes. Use these properly and consistently.

4. Security is the responsibility of every member of this command. I enjoin each commander to stress periodically the safety of handling classified material. Command emphasis of this matter will deny our enemy access to information and material.

"FIRST IN VIETNAM"

Robert E. Joost

ROBERT E. JOOST
Lt Colonel, Inf
Commanding

DISTRIBUTION:

4 + 5 to ea Co
10 to 12th Avn Gp
25 to stock

HEADQUARTERS
115TH AVIATION BATTALION
APO San Francisco 96227

AVAW-F

13 March 1966

SUBJECT: Commander's Combat Note Number 9

TO: See Distribution

SUMMARY OF OPERATIONS 4 MARCH THROUGH 11 MARCH 1966

This week the 115th Aviation Battalion accomplished a variety of combat and combat support missions which contributed significantly toward beating Victor Charlie.

The battalion, or elements thereof, conducted three multi-ground battalion airmobile assaults or extractions; two airmobile assaults in which company sized ground elements were employed; and one airmobile company reinforced the lift of another aviation battalion.

The 197th Aviation Company, in addition to providing their normal armed reconnaissance and marking of LZ's, and armed escort for all airmobile operations, sank 6 sampans and damaged 9 sampans by their lightning Bug operations.

The 74th Aviation Company conducted 42 radio relay missions, 30 command and liaison missions, 26 artillery control missions, 2 flare missions, and one psy-war mission.

The battalion effort on the VC score board for this week is as follows:

An estimated 58 VC killed, a body count of 35 VC killed, 27 structures destroyed and 20 damaged, and 31 sampans destroyed and 31 damaged. This one week's toll is a commendable figure. It is especially significant when it is realized that some ground combat units of brigade size can't match this claim.

On 4 March, the 118th Aviation Company, reinforced by A/501st Aviation Battalion, supported the 1st Aviation Battalion with 15 UH-1D troop carriers and 6 armed helicopters to lift 405 troops of the 5th ARVN Division from Lai Khe into an operational area Northeast of Phu Loi.

On 5 March, the 118th Aviation Company reinforced by A/501st Aviation Battalion, employed 11 troop carriers and 4 armed helicopters to lift 111 troops of the 1st Bde, 1st U.S. Inf Div from a pick-up site fifteen kilometers North of Tan Uyen into a landing zone at Tan Uyen. In the afternoon the same ground element was lifted back to its original departure point.

A major operation was conducted by this battalion, reinforced by aviation elements of the 1st U.S. Infantry Division on 6 March 1966. The unit being

13 March 1966

SUBJECT: Commander's Combat Note Number 9 (cont'd)

supported was the 25th ARVN Division. Fifty UH-1D troop carriers, 27 UH-1B armed helicopters, and 2 Ol-D fixed wing aircraft were assembled to execute this operation. The plan was to extract four infantry battalions from two pick-up sites twelve kilometers South of Tay Ninh during the hours of darkness, and conduct two combat assaults into two landing zones four kilometers Southwest of Cu Chi at daybreak. Due to a dense ground fog in the pick-up area, the pick-up had to be delayed until later in the morning. Eight hundred and twenty ground troops conducted the assault. Moderate automatic weapons fire was encountered during the landing, resulting in one helicopter being hit. The fires of the organic gunships of the airmobile companies, and of the 197th Aviation Company were placed on this enemy fire which served to suppress it. Armed helicopters committed to support the ground battle also took a toll of nine structures destroyed and eleven damaged. During the airmobile assault of the last ground elements, a group of 10 VC were spotted fleeing the area. Gunships of the 197th immediately over the spot and opened fire. The result - eight VC killed and two possibles. Body count was confirmed by ground elements. It is worthy to note that we had some frustrated crews when they realized that their mission didn't permit them to land and recover the VC weapons. It is also regrettable that weather conditions did not permit the night extraction and dawn assault to be executed as planned. As the tactical situation permits, it is intended in the future to conduct more night operations.

At 1440 hours on 8 March, a CIDG company conducting search and destroy operations 10 kilometers West of Tay Ninh was attacked and surrounded by an estimated two company size VC force. The 118th Aviation Company (reinforced) was assembled for a reaction operation and flown to Tay Ninh. There they picked up 200 troops of the 25th ARVN Division and airlifted them into an operational area to reinforce the CIDG unit. This operation again demonstrates the flexibility and rapid response capability of helicopter units. From the time the alert was received by the Battalion Operations Center, until troops were landed in the operational area, only 105 minutes had elapsed. This is an amazingly short time considering that the aircraft had to be recalled from other missions.

The last large operation of the period was conducted on 9 March when two battalions of the 173rd Airborne Brigade assaulted an operational area deep into War Zone D, 16 KM East of Phuoc Hoa. During the troop carrier lifts, ten attached CH-47 helicopters lifted 41 sorties of artillery and supplies into the operational area. Five lifts of the fifty assault helicopters were required to complete the airmovement of the ground elements. Twenty-seven armed helicopters provided air escort and suppressive fire support. Automatic weapons fire was received by flight elements enroute to the operational area and sniper fire was encountered in the landing zone. One aircraft was hit.

During the period the 145th Aviation Battalion provided administrative and combat support to the 1st (US) Infantry Division, 173rd (US) Airborne Brigade and III ARVN Corps.

Operational statistics for the period are as follows:

244

13 March 1966

SUBJECT: Commander's Combat Note Number 9 (cont'd)

Rotary Wing:	Total Sorties	-	4,948
	Total Flying Hours	-	1,818
	Passengers Flown	-	5,984
Fixed Wing:	Total Sorties	-	224
	Total Flying Hours	-	339

The aviation company of this battalion, thus far not mentioned is the 58th. In its silent, modest approach to mission accomplishment, it is already flying 293 hours over program for the month. This is 104 hours over the next highest company. It also has one aircraft less than the other companies.

This battalion has been assigned a new, unique, and challenging mission which will enable us to operate with the U.S. Navy. Plans are being developed at this time and more information will be released as the project develops. Captain Brofer, 197th Aviation Company has been assigned as the Battalion Project Officer.

SUMMARY OF CIVIC ACTIONS

During the period units of the battalion were active in the areas of Community Relations, Education and Training, Health and Sanitation, Construction and Communications. Personnel from the 197th Aviation Company constructed a fence within the An Lac Orphanage, along with organizing a drive to obtain materials to repair a perimeter fence damaged by Viet Cong. In addition the officers and men donated 400 pounds of cookies and candy, 1 case of body soap and 1/2 case of mosquito repellent. The majority of these donations were sent to members of the unit from supporters in the United States. The 118th Aviation Company performed loudspeaker and leaflet support for Psychological Warfare operations for Voice of America for a period of three hours. The officers and men also donated 3,000 \$VN to the Bien Hoa Orphanage along with 300 pounds of rice, 10 pounds of sugar and 1/2 case of wash soap. Doctor Altomonte attended to the sick at the Orphanage. Members of the 120th Aviation Company continued to provide support to the Go Vap Orphanage in the form of \$47.50 MPC, and 2,540 \$VN, one-hundred bags of cement for building projects, 2 cases of cornmeal, 4 cases of evaporated milk and 60 pounds of beans. Captain Wurster from the 129th Med Det surveyed the health needs at the orphanage and concluded that the children receive adequate treatment from their own doctor. A conversational English class was conducted by A/501st Aviation Battalion for the Bien Hoa National Police. Coordination has been made with the MACV Sector Advisor to sponsor a New Life Hamlet in the Ho Nai Refugee area. Many units work in this area but with 80,000 refugees and more arriving each day, there is a tremendous opportunity to help in the traditional American spirit. Our first project will be to field a MEDCAP team.

DISTRIBUTION:

"C" plus
 10 - 12th Avn Gp
 5 - Bn CO
 50 - S-1
 100 - Ba Co

Horst K. Joost
 HORST K. JOOST
 Lt Colonel, Inf
 Commanding

265

HEADQUARTERS
145TH AVIATION BATTALION
APO San Francisco, 96227

AVAW-F

17 March 1966

SUBJECT: Commander's Combat Note #10

TO: See Distribution

1. Wearing of the Combat Army Aviator Badge and Combat Aircraft Crewman Badge is authorized effective this date.
2. Criteria for wear of either of the two badges is receipt of five (5) Air Medals.
3. The Combat Army Aviator Badge will consist of the standard Army Aviator Badge with a bronze star affixed to the center of the coat of arms.
4. The Combat Aircraft Crewman Badge will consist of the standard Badge with the bronze star affixed to the center of the coat of arms.
5. The Aircraft Crewman Badge, to be worn by both gunners and crew chiefs, as authorized and described in para 9.1c, change 11, AR 672-5-1, is the only crewman's badge authorized for wear within this Battalion.
6. It is my desire that Commanders screen all personnel to determine those eligible for this award and take immediate action to present these awards and to standardize their wear.

"FIRST IN VIETNAM"



HORST K. JOOST
Lt Colonel, Inf
Commanding

DISTRIBUTION

"A" Plus
5 ea Co
10 - 12th Avn Gp
5 - Bn CO
50 - S-1

HEADQUARTERS
145TH AVIATION BATTALION
APO San Francisco 96227

AVAW-F

21 March 1966

SUBJECT: Commander's Combat Note
Number 11

TO: See Distribution

SUMMARY OF OPERATIONS 11 MARCH THROUGH 17 MARCH 1966

The 145th Aviation Battalion conducted six major airmobile assaults this week. Four of these major operations were conducted in two consecutive days. Two of these operations were rapid reactions requiring recall and assembly of aircraft from other tasks.

The 197th Aviation Company killed 4 VC confirmed by body count. The company also destroyed 9 sampans (one being 35 feet in length). Four VC installations were destroyed and 8 damaged.

This week the armed helicopters of A/501st Avn Bn, and the 118th, 68th and 197th Aviation Companies had numerous occasions to prove their worth by protecting the troop carrier aircraft and the ground elements they were supporting. The gunners on the troop carriers also had several opportunities to prove to the VC that it isn't healthy to fire at a helicopter.

On 11 March, the 145th Aviation Battalion (Reinf) assembled at the forward command post at 0600 hours to receive the final briefing and organize for combat. This operation was the second airmobile assault conducted in support of operation "Silver City". Fifty UH-1D troop carriers and thirty-one UH-1B armed helicopters were committed in support of the 173rd (US) Airborne Brigade. The Battalion combat assault landed six hundred and fifty-six troops from Bien Hoa into the landing zone eighteen kilometers east of Phouc Hoa.

Since their employment into this area, the 173rd Airborne Brigade has achieved phenomenal success against the enemy. At last count (which is incomplete) for operation Silver City over 300 enemy dead have been counted, and a vast store of arms, documents, and supplies have been captured.

Two major operations were conducted on 14 March. At 0935 hours, two companies of the 145th Aviation Battalion (68th and A/501st), attached to the 11th Aviation Battalion, landed at the staging area two kilometers north of Cu Chi. Twenty UH-1D troop carriers and six UH-1B armed helicopters were committed in support of the 25th (US) Infantry Division. Two hundred and seventy-two troops were airlifted in two lifts from the staging area into the operational area twelve kilometers southwest of Cu Chi.

AVAW-F

21 March 1966

SUBJECT: Commander's Combat Note Number 11 (Cont'd)

Hostile small arms and semi-automatic weapons fire was encountered. This was the first airmobile operation conducted in support of the 25th (US) Infantry Division since its arrival in the Republic of South Vietnam.

At 1100 hours on the same day, fifty-two UH-1D troop carriers and twenty-nine UH-1B armed helicopters were committed in support of the 25th ARVN Division. The Battalion flew to intermediate staging areas located at Trang Bang and Tram Vang where five hundred and twenty troops were loaded and later combat assault landed into an operational area seven kilometers northwest of Duc Hoa. Light to moderate small arms fire was encountered during the first combat assault. The Battalion then flew to Tan An and Ben Luc where an additional five hundred and twenty troops were loaded and combat assault landed into the second landing zone seven kilometers southwest of Duc Hoa and airlifted one hundred troops from that location into the second landing zone. During the entire operation, one aircraft was hit.

At 0230 hours on 15 March the 145th Aviation Battalion reacted immediately to a rapid reaction request from III ARVN Corps. Under the cover of darkness the 145th Aviation Battalion assembled for final briefing and to conduct final organization for combat.

The flight elements departed the assembly area at 0620 hours and picked up the first lift of troops of the 5th ARVN Division at Lai Khe during darkness. With the assistance of the 145th Battalion Pathfinders, the loading proceeded in an orderly fashion. At dawn, two hundred and forty-six troops were combat assault landed into a landing zone eight kilometers south, south-east of Ben Cat. The troop carriers then returned to Bien Hoa and airlifted an additional three hundred and twenty troops into a second landing zone twelve kilometers south of Ben Cat. During the operation the 197th Aviation Company was responsible for evacuating twelve casualties, destroying four structures and damaging eight others.

This reaction operation was initiated with the purpose of reinforcing ARVN elements in the area that had been attacked during the night. The landing areas were chosen with the intent to block the enemy and destroy them. During the landings an intense amount of automatic weapons fire was received from the south eastern edge of the "Iron Triangle". Information was relayed from the ground elements to the 5th ARVN Division Commander, located with the 145th Aviation Battalion Commander in the Command and Control aircraft, that the enemy was in fact withdrawing to the Iron Triangle. It was determined that tactical air would not be on station for at least one half hour. The Division Commander asked what the 145th Aviation Battalion could do to engage the enemy. He was informed we could turn all guns on enemy. As the last elements were landed in the assault, the order was given to all 145th Aviation Battalion elements to prepare for offensive firing. Instructions were transmitted while companies were making a forming turn to echelon the Battalion. Four companies consisting of a total of 37 troop carriers and 19 gunships were spaced one minute apart, echeloned right at an altitude of 1500 feet. On the signal of the lead company all weapons of the gunships and slicks fired into the suspected enemy areas along the

21 March 1966

SUBJECT: Commander's Combat Note Number 11 (Cont'd)

eastern edge of the "Iron Triangle". The width of area covered was extensive, and the density of strikes within the beaten zone was awesome. It is frustrating not to know the extent of damage incurred on the enemy. It is certain that we caused damage, since this fire covered the area from which we were receiving automatic weapons fire. A total of seventy-eight thousand rounds of 7.62 ammunition, three hundred and fifty 2.75 inch rockets, and one hundred and thirty-five rounds of 40MM ammunition were expended during the one firing pass.

At 0830 hours, on the same day, the 145th Aviation Battalion (Reinf), again assembled for combat in support of another airmobile assault. Forty-three UH-1D troop carriers and twenty-seven UH-1B armed helicopters flew to intermediate staging areas at Cu Chi and an area eight kilometers northwest of Duc Hoa. From these two locations four hundred and ten troops of the 25TH ARVN Division were airlifted in one combat assault into the operational area six kilometers west of Duc Hoa. Small arms and semi-automatic fire was received in the vicinity of the landing zone and one of the attached aircraft was hit.

On 16 March, the 145th Aviation Battalion (Reinf) reacted immediately to a rapid reaction initiated by the 1st (US) Infantry Division in support of the 173rd (US) Airborne Brigade. At 0935 hours the Battalion Operations Center was notified of the rapid reaction. By 1200 hours, twenty-eight UH-1D troop carriers and sixteen UH-1B armed helicopters had been recalled from III ARVN Corps support missions, assembled at the forward command post and lifted two hundred troops of the 1st (US) Infantry Division (2nd Brigade) into a landing zone twenty-two kilometers north of Bien Hoa. Throughout the remainder of the day an additional twelve hundred and thirty troops were lifted from Lai Khe, Long Than North (Bearcat), and Phuc Vinh into two landing zones in the operational area. Due to the immediate requirement for additional support in the second landing zone, troops were repositioned from one landing zone to the other. Small arms and semi-automatic weapons fire was encountered in the vicinity of the landing zones; however, there were no aircraft hit. Throughout the entire operation, the flight elements arrived at the pickup sites prior to the time the ground elements were organized for air movement. The rapidity with which this rapid reaction was accomplished indicates the flexibility which is ever present within the companies of the Battalion.

On 17 March, the 68th Aviation Company was attached to the 11th Aviation Battalion to support the 25th (US) Infantry Division in search and destroy operations being conducted eight kilometers southeast of Tay Ninh. Ten UH-1D troop carriers and two UH-1B armed helicopters were involved in the operation which was staged from Phu Loi. One hundred and twelve troops of the 2nd Brigade, 25th (US) Infantry Division were airlifted in one lift and combat assault landed into the operational area.

During the period, the 74th Aviation Company conducted the following missions:

3
268

AVAW-F

21 March 1966

SUBJECT: Commander's Combat Note Number 11 (Cont'd)

Command and Liaison	- 39	Air Escort	- 21
Radio Relay	- 13	Visual Reconnaissance	- 76
Artillery Adjustment	- 27	Photo	- 1
Air Control	- 30	Forward Air Control	- 1
Surveillance	- 12	Logistics	- 5

During this period the 145th Aviation Battalion also provided normal administrative and combat support to the 1st (US) Infantry Division, 173rd (US) Airborne Brigade and III ARVN Corps.

Operational statistics for rotary wing aircraft in support of operations are as follows:

Total Sorties	- 4221
Total Flying Hours	- 1668
Passengers Flown	- 6196

Operational statistics for fixed wing aircraft in support of operations are as follows:

Total Sorties	- 252
Total Flying Hours	- 538

Due to the large influx of new aviators in the Battalion a vigorous training program is now under way within the companies to insure that all newly assigned personnel receive a detailed and thorough standardization flight check prior to flying on III Corps aviation support missions.

SUMMARY OF CIVIC ACTIONS

This week the 145th Aviation Battalion accomplished a variety of Civic Actions in its effort to expand the Civil Affairs Program. In the area of commerce the Battalion and subordinate units provided approximately 300 jobs for the local populace on a continuous basis, broken down as follows:

Bn HQ & HHD	- 30	118th Avn Co	- 70
68th Avn Co	- 50	197th Avn Co	- 50
74th Avn Co	- 28	A/501st Avn Bn	- 41

The 68th Avn Co relocated 201 ARVN and refugees on three separate operations conducted in the Xuan Loc, Tanh Ninh area. In addition they transported 3,500 lbs of food and personal belongings associated with the move. Preliminary planning was accomplished with U.S. Advisors at Can Co for the company's sponsorship. The 68th has also extended an offer to help the An Phong welfare organization when assistance is needed.

The 74th accomplished initial coordination with the Phu Loi Civic Actions Coordinator and it is anticipated that work will begin very soon. Help is needed in the Education, Community Relations and Construction fields.

* 270

21 March 1966

SUBJECT: Commander's Combat Note Number 11 (Cont'd)

The 118th accomplished Civic Actions in virtually all areas. One hundred civilians were evacuated from a village in the Song Be area that was supposed to be over-run by Viet Cong. At the same time two gunships evacuated two civilians that needed immediate medical attention. Both of these operations were done under extreme hazardous conditions and in only a few hours duration. The gunships received several rounds of small arms fire while completing the medical evacuation. Twenty-two bags of rice which were located on a search and destroy mission in the operational area north of Phu Loi were lifted to home station. The rice was donated to help relieve some financial burden of the Bien Hoa Orphanage. In addition the officers and men have volunteered their off-duty time to help construct plywood and tin-lined cupboards at the orphanage. Donations for the week were: Two cases of jam, 50 cans of bread, 12 lbs of sugar, 100 lbs of peanuts, 600 lbs of white rice, 200 lbs of powdered milk, 1 case of bath soap, 1 dozen wash cloths, 15 tooth brushes and tooth paste packs, 6 dozen diapers, assorted children's clothes, 10 lbs of salt, and 2 cases of candies. The following medical supplies and cleaning products were donated by the officers: 1 case of chlorine bleach, 1 case of insect spray, 1 case of aureomycin eye ointment, and 2 boxes of assorted vitamins to fulfill their daily needs. The 118th also flew a psychological warfare mission for three hours duration. During the mission the Voice of America and leaflets offered the words of freedom and safety from the South Vietnamese Government in the Tan Uyen area. Doctor Altomonte treated patients again at the Leper Colony for various illnesses other than leprosy. This assistance has greatly helped in isolating the disease and has lessened the suffering of those afflicted with leprosy. SPl Amisano has been giving English classes to the children around Cong-Ly. He is affectionately known as the "teacher" and this kind of people to people program is the very foundation of our civic actions here in Vietnam.

The 197th continued to provide support to the An Lac Orphanage in the areas of Health and Sanitation, and Community Relations. Donations included 1 case of body soap, 5 lbs of tooth brushes and tooth paste, 40 lbs of flour, 15 lbs of sugar, and 20 lbs of candy. Emphasis is being placed on improving the cleanliness of the children. Civic organizations in the U.S. supporting the 197th sponsorship of the orphanage have indicated that 80 lbs of clothes is on the way and it will be a continuous program from then on.

A/501st Avn Bn was active in the areas of Community Relations, Transportation and Education. An English class was taught for the National Police of Bien Hoa. The officers and men donated 12,875 \$VN worth of clothes, writing pads, readers, and coloring books which were presented to the Catholic Orphanage of Bien Hoa. On 13 March two helicopters assisted the 5th ARVN Division in relocating 45 civilians, bag and baggage, from Song Be to Duc Phuong. Also during the course of normal missions 300 lbs of USAID rice and 200 lbs of school supplies were transported to a remote village north-east of Song Be.

The effort to expand civic action activities has shown some real

8271

AVAW-F

21 March 1966

SUBJECT: Commander's Combat Note Number 11 (Cont'd)

progress in the last week despite the loss of the 120th Aviation Company which was very active in Civil Affairs.

Horst K. Joost

HORST K. JOOST
Lt Colonel, Inf
Commanding

DISTRIBUTION:

"D"

266

HEADQUARTERS
145TH AVIATION BATTALION
APO San Francisco, 96227

AVAN-F

28 March 1966

SUBJECT: Commander's Combat Note
Number 12

TO: See Distribution

SUMMARY OF OPERATIONS 18 MARCH THROUGH 24 MARCH 1966

The 145th Aviation Battalion conducted two major airmobile assaults, and two extractions, and on five occasions provided aviation reinforcement to other units during the period. Included was reinforcement to the II Corps and IV Corps aviation.

The 197th Aviation Company sank three sampans and damaged three. The company also destroyed two V.C. structures. During the support of the 25th ARVN Division, three armed helicopters evacuated 14 ARVN casualties.

On 18 March, the 145th Aviation Battalion employed 28 UH-1D troop carriers and 18 UH-1B armed helicopters to support the 25th (ARVN) Division in air assault operations 13 kilometers southwest of Duc Hoa. From the staging area at Duc Hoa, 595 troops were airlifted in three successive assaults. Light small arms and automatic weapons fire was encountered on the 2nd and 3rd assaults. Three aircraft were hit.

During the 2nd assault ten Viet Cong were sighted in the open 400 meters north of the landing zone. Although tactical air, organic artillery and mortars were available and could have been used, the airmobile force Commander took advantage of the flexibility, fire power and rapid response of the armed helicopters. The target was immediately engaged and neutralized with seven Viet Cong estimated killed.

At 1620 hours, the 145th Aviation Battalion responded to a rapid reaction notification to air land one battalion (317 troops) from the 25th (ARVN) Division to reinforce the troops that had been air landed earlier in the day. The responsiveness of the Aviation Battalion was clearly evident as the entire operation, from notification to termination, took only one hour and thirty minutes. Moderate ground fire was received from the vicinity of the landing zone and two aircraft were hit. Thirty one ARVN casualties were evacuated, under fire, after the assault troops were landed. Only through the close covering fire provided by the gunships was it possible to remove these casualties without losing an aircraft to enemy fire. All personnel participating are to be commended for their courageous behavior in the face

of enemy fire. I also want to commend Lieutenant Holcomb, 74th Aviation Company for his quick thinking and actions, while flying fixed wing cover in support of this operation.

The 118th Aviation Company, also on this day, committed five UH-1D troop carriers and four UH-1B armed helicopters to extract 46 ARVN Special Forces from a site 25 kilometers north of Suoi Da, in support of operation MARCH EAGLE I.

On 19 March, Company A/501st and the 118th Aviation Company teamed together to extract troops of the 1st Brigade, 1st Infantry Division (US), from a site 20 kilometers southeast of Phuoc Vinh. Ten UH-1D troop carriers and two UH-1B armed helicopters were used to extract 112 troops in two air-lifts.

The 145th Aviation Battalion employed seventeen UH-1D troop carriers and ten UH-1B armed helicopters in support of III (ARVN) Corps missions on 20 March 1966.

On 21 March, the Battalion supported the 173rd Airborne Brigade in Operation SILVER CITY by employing thirty-three UH-1D troop carriers and eight UH-1B armed helicopters to extract 1186 troops of the 1st and 2nd Battalion, 503rd Airborne Infantry in six air lifts.

In the afternoon the Battalion supported III (ARVN) Corps with twenty nine UH-1D troop carriers and eight UH-1B armed helicopters. Three hundred CIDG troops were extracted from a landing zone 16 kilometers north of Xom Cat and air lifted to Bien Hoa.

Operation SILVER CITY terminated at 1635 hours on 22 March, as the 145th Aviation Battalion employing forty UH-1D troop carriers and nineteen UH-1B armed helicopters, extracted six hundred and ninety troops of the 1st Battalion, RAR from a landing zone along the Song Be River. In addition to the troops, the aircraft lifted 4.2 mortars, several Engineer assault boats and other crew-served weapons.

The flexibility and rapid reaction of the 145th was proven again as the Battalion responded to a late request by the ground commander to depart the staging area thirty minutes earlier than scheduled.

Offensive firing highlighted the operation. Seven UH-1B armed helicopters conducted offensive firing along the banks of the Song Be River opposite the landing zone. The remaining twelve UH-1B armed helicopters were placed in support of the ground commander. While in orbit east of the landing zone they received small arms and automatic weapons fire from a location four kilometers east of the landing zone. The target was immediately engaged and neutralized.

On 23 March, the 68th Aviation Company, reinforced by the 118th Aviation Company, responded to a rapid reaction request to support IV (ARVN) Corps. Ten UH-1D troop carriers and three UH-1B armed helicopters air lifted two hundred and seventy nine troops in one air assault and four extractions in the vicinity of Muc Hoa.

Three UH-1B armed helicopters from the 197th Aviation Company supported the 25th (ARVN) Division at Duc Hoa.

On 24 March, the 118th Aviation Company reinforced the 1st Aviation Company, 1st (US) Infantry Division, airlifting 185 troops with five UH-1D troop carriers in five combat air assaults. Enemy fire was received in vicinity of the landing zone.

On this date, A/501st Aviation Company departed this station to reinforce the aviation of the II Corps. The unit departed in a posture prepared to operate in the field for an extended period. With only a short warning, aviation again proved their responsiveness to mission accomplishment, when this company moved a couple of hundred miles and was ready to operate on arrival. These short notice, field operations will become more frequent. Therefore, all companies must update their plans for such contingencies.

During the week, the 74th Aviation Company accomplished the following tasks:

<u>TYPE MISSION</u>	<u>TOTAL NUMBER</u>
Visual Reconnaissance	64
Forward Air Control	2
Radio Relay	20
Surveillance	25
Artillery adjustment	21
Naval Vessel escort and road column Observation	35
Command Liaison	19
Logistics	3

Operational statistics for rotary wing aircraft in support of operations are as follows:

Total Sorties	4315
Total Flying Hours	1551
Passengers Flown	5045

Operational Statistics for fixed wing:

Total Sorties	229
Total Flying Hours	538

This week, I am pleased to announce that the first Combat Crewman's Badges were awarded to Sergeant Major L. A. DuBrey, the Battalion Sergeant Major, and SP5 Buster R. Timberlake, crew chief for the Battalion Commander's Command and Control aircraft. These were the first awards of the many Combat Crewman wings and Combat Aviator wings that have been earned by members of this Battalion. Wear these wings proudly.

SUMMARY OF CIVIC ACTIONS

During the week the 145th Aviation Battalion Hq & Hq Det continued its plans to expand Civic Actions in the surrounding communities. Three thousand pounds of Viet Cong captured rice was donated to the parish through the chief. The parish, in turn, will distribute the rice to refugees who are unable to provide for themselves. In this category there are many blind, incapacitated, ill, and elderly refugees. Approximately one hundred adults and children observed this demonstration of good will which will do much to foster the Vietnamese-American Relations. On Sunday, several officers attended Catholic Mass at the refugee village, and surveyed the school needs. Pictures were taken, and information gathered to send home in an effort to solicit home town help.

The 68th Aviation Company was active in the civic action area by evacuating two hundred and fifty eight ARVN dependents and refugees on four different operations in as many days. One of the evacuation operations was from a village recently over-run by the Viet Cong on two separate occasions. Incident to the movement of the dependents and refugees, 12,000 pounds of foodstuff, and personal belongings were moved.

This week the 74th Aviation Company obtained volunteers, written material, and classroom spaces to teach Conversational English classes to Vietnamese children in Phu Cuong, two afternoons each week. Two volunteers are aiding a Regional Forces Platoon in construction of new living quarters in Phu Cuong. The Platoon presently lives, with dependents, in two crowded buildings. The officers and men donated condensed milk, fresh milk, canned hams, and orange juice to a local school to supplement the children's diet. For construction at the school, five bags of cement were donated.

The 118th Aviation Company was active in many areas of civic affairs. The officers of the 118th Avn Co donated thirteen dozen "Dixie-Cups" of ice cream to the Bien Hoa Orphanage. The celebration was a complete surprise to the children who gave their hardest thanks. It will be a long time ~~before~~ before this act of generosity is forgotten. The company also donated the following list of items to the orphanage: Flour, sugar, cases of canned food, soap for personal use, baby night shirts and assorted children's clothing, salt, cooking oil, powdered milk, and a few toys of various kinds donated by relatives from the States. Doctor Altomonte donated another six hours work at the Leper Colony on Sunday. SP4 Amisano again donated time each day this past week to teaching the children on Cong Ly Street English at night. The classes are approximately 1 1/2 hours long and recently a couple of the Bien Hoa National Police also attended.

The 118th Aviation Company, in the course of their operational missions, transported a total of 250 lbs of medical supplies and dressings and evacuated ten civilians from Da Thelgen area because of injuries and tuberculosis.

Despite the fact that the 197th Aviation Company was engaged in moving from Saigon to Bien Hoa, the company still found time to accomplish civic actions in their support of the An Lac Orphanage. The company has already explored the possibility of supporting a boys farm in the Bien Hoa area that is affiliated with the An Lac Orphanage. Two cases of body soap were donated to the orphanage. This soap was a gift from people of the State of New Hampshire, in response to a request for support. The officers and men donated: rice, dried beans, cases of cherries, cases of dehydrated potatoes, cases of dehydrated eggs, cases of egg noodles, cases of jollo, a case of orange juice, a case of cocoa, and approximately 20 pounds of clothing.

A/501st Aviation Battalion was active in the area of community relations and education. On 24 March, 1500 pounds of Viet Cong captured rice was donated to the Catholic orphanage of Bien Hoa. Also a conversational English class was taught to the National Police of Bien Hoa.

Horst K. Joost

HORST K. JOOST
Lt Colonel, Inf
Commanding

DISTRIBUTION
"D"

HEADQUARTERS
145TH AVIATION BATTALION
APO San Francisco, 96227

AVAW-F

1 April 1966

SUBJECT: Commander's Combat Note
Number 13

TO: SEE DISTRIBUTION

SUMMARY OF OPERATIONS 25 MARCH THROUGH 1 APRIL 1966

Business was slow this week. Operations consisted of company size or smaller elements of the 145th Aviation Battalion conducting independent or reinforcing operations.

The score for the 197th Aviation Company is one sampan sunk and two damaged, and two V.C. structures destroyed. During this period the company moved to its new home at Bien Hoa.

From 25 March through 27 March, the Battalion provided aircraft in support of normal III Corps (ARVN), II FFORCEV and MACV missions.

On 28 March, the 68th Aviation Company employed nine troop carriers and six armed helicopters to air assault with 454 CIDG troops into three landing zones in the vicinity of TAY NINH. The same troops were extracted on completion of the raids. Offensive firing highlighted the "Tiger" Company operation with a result of twenty seven VC structures destroyed, twenty five damaged, and two sampans sunk.

Company A/501st returned from a four day reinforcement mission in the II Corps area. The company got its first taste of operating independently under field conditions. Many lessons were learned from the move while conducting operations in an environment where density altitude conditions were normally at 5000 feet. Employing ten UH-1D troop carriers and five UH-1B armed helicopters, 609 troop and nine tons of supplies were lifted in sixteen combat assaults and one extraction.

On 29 March, the Battalion responded to a rapid reaction request from III Corps (ARVN) to airlift elements of the 5th ARVN Division into an area northeast of PHU CUONG. The mission was to secure three pallets of 105mm howitzer ammunition that had been jettisoned from a C-123 aircraft and to prevent the ammunition from falling into V.C. hands. Company A/501st, reinforced by one troop carrier from the 68th Aviation Company and three armed helicopters from the 118th Aviation Company, departed the stage field and were ready to pick up the ground elements at Phu Loi, one hour after being alerted.

A total of one hundred and eleven troops were landed on two landing zones nine miles northeast of PHU CUONG.

On 30 March, Company A/501st, employing eight UH-1D troop carriers and two small helicopters, airlifted ninety-nine troops of the 1st (US) Infantry Division from Bien Hoa to a landing zone fifteen kilometers north of Tan Uyen. In the afternoon the company again supported the 1st (US) Infantry Division by lifting two hundred and seventy-two troops in five assaults from Bear Cat to a landing zone twenty kilometers southeast of Bear Cat.

On 31 March, Company A/501st reinforced the 1st Aviation Battalion, 1st (US) Infantry Division with seven troop carriers and airlifted one hundred and ninety nine troop in five combat air assaults from Vung Tau to a landing zone three kilometers east of Phu My.

During the week the 74th Aviation Company conducted the following tasks:

	<u>Sorties</u>
Visual Reconnaissance	87
Radio Relay	22
Forward Air Control	1
Surveillance	42
Command Liaison	16
Escort	49
Artillery Adjustment	47
Logistics	9

On 26 March the 74th Aviation Company celebrated their first anniversary since activation. During the one year period they have set a commendable record of 22,438 flying hours, consisting of 15,503 sorties. Congratulations and continued success.

Operational statistics for the rotary wing aircraft of the Battalion for this week's period are as follows:

Total Sorties	5004
Total Flying Hours	1495
Passengers Flown	4865

Operational statistics for fixed wing aircraft for the Battalion are as follows:

Total Sorties	333
---------------	-----

The 145th Aviation Battalion has gone to sea. We now have a task force of gunships which are operating with the U.S. Navy with the mission of providing aerial fire support for naval patrol boats operating in the river and delta areas to destroy the Viet Cong and to secure shipping lanes. At present two armed helicopters operate from the deck of the Seventh Fleet Dock Landing Ship U.S.S. Belle Grove. The teamwork developed between the Army helicopter crew and the Navy landing teams is something to behold when a helicopter is launched and landed.

The helicopters were first landed aboard the vessel on 25 March. The first rapid-reaction was called on 26 March, to assist the Marine Landing Force during operation JACK STAY in the Rung Sat Special Zone. The operation consisted of directing an ambush party from the air to move to a safe area, and to escort a river patrol boat employing Underwater Demolition Teams. On 27 March, the gunships were launched to escort medical evacuation patrol boats. Also on that day the fire team was launched to support a swift boat that was attacked by V.C. gunfire. The fire team expended twenty four rockets and 5,000 rounds of 7.62 caliber ammunition against the VC ground fire.

Captain D. R. Brofer is the Project Officer and commander of the gunship task force. This project will soon be expanded and all companies will provide crews and aircraft for the Task Force. The Army crews are enthusiastic about the duty and I was pleased to have the Captain of the U.S.S. Belle Grove tell me that he has worked with the Army on numerous occasions but he has never met a more gung-ho, mission-oriented group of Army people as these gun crews.

In the field of training, a program has been initiated by the Battalion in the adjustment of artillery fire. The goal is to have every rotary wing and fixed wing aviator proficient in the adjustment of artillery fires.

SUMMARY OF CIVIC ACTIONS

The 145th Aviation Battalion Hq and Hq Det conducted its biggest operation to date, in the area of Community Relations. 30,000 pounds of bulgur wheat were obtained from the Catholic Relief Society through coordination with the III Corps G-5. The bulgur was transported to the Bui Vinh refugee village during a two day operation. This donation constitutes the basic staple for approximately 2000 refugees for one month. The bulgur will be distributed to the needy by members of the Hq and Hq Det and members of the community under the supervision of the GVN. A fund was established by the Battalion Headquarters to provide money for approximately 60 school children to attend the elementary school, and also buy school supplies. Contributions received on March 31st amounted to 17,000 piasters, enough to sustain the program for the remaining school year. 2000 piasters were turned over to the Parish Chief for March and April. In the area of communication, 150 pounds of books, magazines and leaflets were obtained through JUSPAO and donated to the Bui Vinh refugee center. These materials will be used to stock a reading room and will contribute to the psychological warfare effort.

In addition to normal missions the 68th Aviation Company evacuated or

relocated 119 ARVN dependents and refugees on four separate operations. 11,500 pounds of personal belongings and foodstuffs were also transported in conjunction with these movements. In coordination with the Korean Hospital, four Vietnamese civilians were transported from Phu My to the Korean Hospital for surgery. Aircraft returning from normal missions provided this transportation. On the spot first aid was also administered by a gunship crew, on a normal mission at Vo Dat, to two small children with severe cuts.

The 74th Aviation Company was active in the areas of Community Relations, Sanitation, Health, and Construction. The officers and men donated 20 cartons of dixie cups to the Phu Cuong school. In addition, 1 case of tooth paste was donated to the school children along with instructions for its use. Two volunteers continued to assist a Regional Forces Platoon in the construction of new living quarters.

The 118th Aviation Company was very active this week in civic action activities. Armed elements evacuated two injured children and one woman from a village over-run by the Viet Cong, thus saving their lives. The Officers and men donated the following to the Bien Hoa orphanage: Brown sugar, powdered soups, assorted jams, canned vanilla pudding, raisins, corn beef, canned beef, peanut butter, egg noodles, white rice, powdered milk, boxes of clothing, and toys. Doctor Altomonte made his weekly visit to the Leper Colony and treated fifteen patients for common illnesses. A project was also completed at the orphanage to improve the sanitation of the toilet area. SP/4 Amisons again held Conversational English classes for the local residents of Cong Ly Street. In addition to normal missions, the airmobile elements re-located approximately 50 refugees from a Viet Cong controlled outlying area of Song Be to a New Life Hamlet in Song Be.

The 197th Aviation Company was busy this week completing its move to Bien Hoa. However, on 25 March the home of one of its Vietnamese employees was completely destroyed by fire. The 197th immediately responded by donating food and clothing for the family and construction material for a new house. In the area of commerce the unit has provided employment for approximately 20 local Vietnamese in the Bien Hoa area.

A/501st Aviation Battalion, although on an operational mission near Ban Le Thuot for most of the period, continued its Conversational English class for the National Police of Bien Hoa. Representatives of the company visited a Montagnard village in the operation area when it was learned that the villagers would not leave the village to hunt and fish because of their fear of the armed helicopters. This visit did much to foster Vietnamese-American relations.



HORST K. JOOST
Lt Colonel, Inf
Commanding

DISTRIBUTION
"D"

281

HEADQUARTERS
145TH AVIATION BATTALION
APO US Forces, 96227

AVAW-FB

5 April 1966

SUBJECT: Commander's Combat Note
Number 14

TO: See Distribution

VIETNAMESE COMMUNIST ORGANIZATION

The Viet Cong Military and Political apparatus in South Vietnam is an extension of the Communist Military and Political structure in North Vietnam.

Political direction and control of the Viet Cong is supplied through the Central Committee of the Lao Dong Party, which is the Communist Party of North Vietnam, led by Ho Chi Minh. The Central Committee, in turn, issues directives through its Reunification Department to the Central Office for South Vietnam or COSVN. COSVN is the headquarters of the Viet Cong movement in South Vietnam and is located in Tay Ninh Province near the Cambodian border.

Under COSVN are five regional units plus the Special Zone of Saigon-Cholon-Gia Dinh. Each has a Regional Committee which is responsible for liaison, propaganda, training, personnel, subversive activities, espionage, military bases and the like. Below each region are similarly organized committees at the province and district levels. The villages and hamlets which comprise the bottom of the structure are organized into party cells based upon geography or upon social or occupational groups. The development of the party unit and the extent to which it operates openly is determined primarily by the extent of VC control over the area concerned.

An elaborate propaganda screen has been devised to influence world opinion and to hide the Communist direction of Viet Cong activities. The National Front for the Liberation of South Vietnam was established in 1960, to create the illusion that the aggression in South Vietnam is an internal rebellion, by many groups, against the established government. To carry the illusion further, a Peoples's Revolutionary Party was organized in order to explain Communist presence in the Front and to make it appear that they are only one of the several affiliated organizations in the Front.

However, the NFLSVN must be recognized for what it is and therefore, in official usage, we do not give it status by using the term National Liberation Front or National Front for the Liberation of South Vietnam.

A key element in the Viet Cong effort is an elaborate organization in Hanoi called the Central Research Agency or CRA. The CRA handles the North Vietnamese intelligence effort on a worldwide scale, but the main focus of its attention is South Vietnam. Inside the Republic the intelligence network is quite extensive and includes the supervision and handing of agents, supplies, equipment, and communications. Party and military intelligence units work closely with the CRA. Taken as a whole, the North Vietnamese intelligence operation in support of the Viet Cong is one of the largest of its kind in the world.

The military activities of the Viet Cong are the responsibility of the Ministry of Defense and the high command of the North Vietnamese Army, under close supervision from the Lao Dong Party and in coordination with COSVN. The five military regions and the capital zone are the same as those of the VC political organization. The military structure of the Viet Cong is an integral part of the political machinery that controls every facet of the VC activity in South Vietnam. Each political headquarters has a military component which controls day-to-day military operations. Similarly, each military headquarters has a political element. This meshing is designed to insure the closest cooperation in support of the total Communist mission. It also guarantees political control over the military. Thru COSVN, and its associated military headquarters, Hanoi directs its principal military units and their operations in the South.



HORST K. JOOST
Lt Col Inf
Commanding

1 Incl
Diagram, Vietnamese Communist
Organization

DISTRIBUTION

"D"

VIETNAMESE COMMUNIST ORGANIZATION

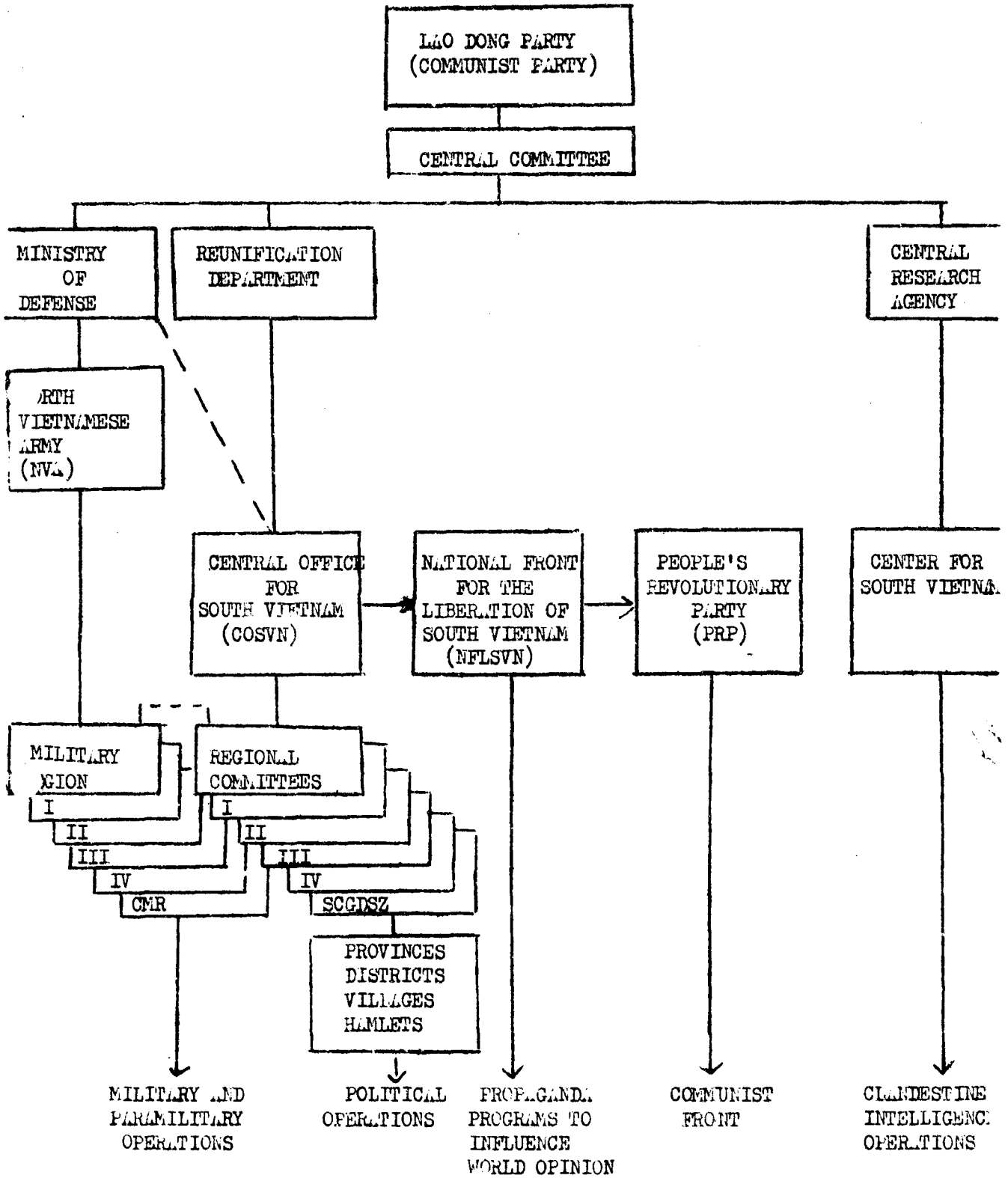

HEADQUARTERS
145TH AVIATION BATTALION
APO San Francisco, 96227

AVAW-F

9 April 1966

SUBJECT: Commander's Combat Note
Number 15

TO: SEE DISTRIBUTION

SUMMARY OF OPERATIONS 1 APRIL THROUGH 7 APRIL 1966

The 145th Aviation Battalion made great strides this week in demonstrating that Army Aviation is a significant and vital part of combat operations in defeating the Viet Cong in Vietnam.

Evidence of damage to the Viet Cong from this Battalion's efforts is obvious from this weeks score board: Nineteen V. C. killed, thirty-nine estimated killed, three wounded prisoners, thirty-three V. C. structures destroyed and twenty damaged, eighteen sampans sunk and fourteen damaged, and one truck destroyed.

One of the major efforts this week was the aviation support of the 2nd Brigade, 25th (US) Division during operation "CIRCLE PINES" from 30 March to 4 April. All units of the Battalion provided support, however, 118th Aviation Company was assigned mission responsibility. The area of operations was to the north of a line running from Cu Chi to Trung Lap and to the Saigon River. This operation was a classic example of how aviation should and should not be employed. Some significant lessons were learned. The most significant being that Army Aviation can't be dispatched as taxi cabs to perform a mission. Close coordination and understanding must be established between the aviation unit commander and the support ground commander, and the individual pilot must know the current situation. It was discovered that, during the initial days of the operation, aircraft that were being assigned to support the brigade on a single mission basis were being subjected to enemy fire when lifting resupply to forward elements. This fire ranged from single shot sniping to medium and heavy automatic weapons fire. In an attempt to bring order to this situation, Major Underwood, Commanding Officer of the 118th Aviation Company was assigned the mission to support the operation until termination. Troop carrier aircraft and gunships of all other companies of the Battalion reinforced the 118th Aviation Company during the remainder of the operation as required. By close association with the command and staff elements of the supported Brigade, the aviation commander was able to advise how and where to best use airlift and aerial fire support. He was also able to study the enemy fire techniques and take appropriate counter measures to protect the aircraft and incur maximum damage to the enemy. At one stage of the operation the Brigade was supported by eleven troop carrier aircraft and fourteen armed aircraft. By the employment of appropriate tactics with gunships against enemy ground fire, hits on troop carrier aircraft were considerably reduced and the score of V.C. kills mounted. After the aviation leadership, advice and management was established, the supported brigade enjoyed the type of support that aviation is designed to produce.

285

Also, no aircraft stood idle - this critical resource was fully used. Within these few days, aviation was employed as follows: Lift supplies from the support base to forward employed elements; command, control and liaison for commanders and staff; radio relay; armed escort of ground columns, reconnaissance by fire in advance of ground columns; armed escorts for troop carrier aircraft; preparation by fire of a landing zone; reconnaissance and marking of a landing zone; airlift of troops in an airmobile assault; armed reconnaissance of a river and aerial fire against V.C. river traffic; armed aircraft strikes on targets designated by forward ground elements which were too close to friendly troops for tactical air engagement (some strikes were 100 meters in front of friendly troops); and medical evacuation of wounded. What started out to be an operation where aviation was piecemealed to support the Brigade for occasional missions, turned out to be a well coordinated operation in which aviation was effectively and economically used and contributed significantly to the success of the operation. This reversal is due to the fact that an aviation unit commander was assigned a mission and he felt the responsibility toward that supported unit. That personal responsibility in fact kept his company maintenance working overtime to come up with several more aircraft available for missions than programmed.

A summary of the result achieved and resources employed for this operation is shown below:

	<u>118th</u>	<u>A/501st</u>	<u>68th</u>	<u>197th</u>	<u>TOTAL</u>
Total Flying Hours	253	77	45	33	408
Total Sorties Flown	913	26	132	26	1097
Total Tons Cargo	90	19	7	—	116
Passengers Lifted	879	273	40	—	1192
Medevacs	17	3	2	1	23
V.C. Structures destroyed/damaged	10/5	2/2	7/5	4/6	23/18
V.C. Sampans destroyed/damaged	3/10	0/0	6/7	0/0	9/10
Total tasks Performed	1197	341	90	32	1660
Rounds expended					
7.62mm	55,000	10,000	16,000	24,000	105,050
40mm	500	0	80	50	630
Rockets	234	28	52	98	412
V. C. KIA Confirmed	5	0	0	4	9
Estimated	10	3	3	15	31

During the week the 197th Aviation Company, operating on independent missions (excluding the support rendered in the operation described above) claimed eight sampans sunk, four sampans damaged, ten V.C. structures destroyed, one truck destroyed and three V.C. killed.

The combined effort of the 145th Aviation Battalion conducted an operation in support of Operation GREENE EAGLE in the Tay Ninh area on 5 April. This operation consisted of conducting an air assault of 200 CIDG troops into an area to establish security for an artillery support base. 105mm howitzer artillery was then airlifted by Chinooks into the secured base and artillery registered. The next air assault consisted of lifting 710 CIDG troops into two landing zones for the conduct of a search and destroy operation. This air assault was highlighted by the employment of tear gas dispensed by helicopters to create a barrier to an avenue of approach into the landing zone. After the tear gas was dispensed, offensive fire was conducted over the tear gassed area by dropping sixty 81mm mortar rounds from a helicopter, and by firing armed helicopters and machine guns from troop carrying aircraft. The fire power accounted for four enemy confirmed killed, three wounded prisoners, and a possible four other V.C. killed. Later in the day the assaulting force was extracted and reemployed in another airmobile assault against a suspected V.C. location. During this operation the 197th Aviation Company was also credited with three V.C. killed and an estimated four V.C. killed from the results of strikes placed against enemy ground fire.

On 7 April, the 68th Aviation Company conducted an airmobile assault with 190 RF/PF troops in an area 15 kilometers south of Hon Quan.

The 74th Aviation Company performed the following tasks during the period:

	<u>Tasks</u>
Visual reconnaissance	100
Escort Missions	40
Psychological warfare	3

The armed aircraft task force of this Battalion, operating with the Navy, has been designated Task Force Sea Wolf. At present the task force is operating aboard the U. S. S. Belle Grove in the Rung Sat Special Zone. During the week these gunships provided forward air control support for Navy tactical air strikes, escorted friendly patrol boats and LST's and LCM's during the U. S. Marine Corps extraction from the Rung Sat Special Zone, conducted night and day reconnaissance, which located a V.C. bunker and tunnel complex, and conducted strikes on enemy positions and sampans. With a result of one sampan destroyed and two structures damaged. A gunship also evacuated a wounded Vietnamese Marine.

Training in Artillery adjustment from an aerial platform has been initiated by the Battalion this week.

The operational statistics for the period are:

Rotary Wing:

Total Sorties	4428
Total Flying hours	1404
Passengers	5421

277

Fixed Wing:

Total Sorties	329
Total Flying hours	556

The following awards were received by the Battalion:

Distinguished Flying Cross	6
Bronze Star "Valor"	1
Air Medal "Valor"	11
Army Commendation Medal	3
Purple Heart	10

The following promotions were received:

Capt to Major	2
E-2 to E-3	11
E-3 to E-4	3
E-4 to E-5	11
E-6 to E-7	1

SUMMARY OF CIVIC ACTIONS

The Hq & Hq Detachment donated 4500 pounds of rolled wheat, candy and canned goods to the Bui Vinh refugee center.

The 68th Aviation Company evacuated or relocated 114 ARVN dependents and refugees in the WO DAT, XUAN LOC area. 10,000 pounds of personal belongings and foodstuffs were airlifted concurrently with the dependents and refugees. Final coordination was made at Can Gio by representatives of the 68th Aviation Company, in an effort to begin several projects in that community.

The officers and men of the 74th Aviation Company distributed coolaide to the children of the 5th ARVN Division Dependents School at Phu Loi. In addition, coolaide, orange juice, candy and cookies were donated to the HIET BINH XA School. Lt Ebert and Sp/4 Montey conducted a conversational English Language Seminar for the faculty of the HIET BINH XA School.

The 118th Aviation Company evacuated twenty-five refugees from a 25th Inf Div operational area. Armed elements medically evacuated five Montagnards from a V.C. controlled area to HON QUAN. As a result of this evacuation, intelligence was gained, and later the same day armed elements made strikes based upon this intelligence. Here is another example of an immediate pay-off of Civic Action efforts. Donations to the Bien Hoa Orphanage this week consisted of a large amount of foodstuffs, assorted toys, plastic baby bottles with nipples, and clothing for infants and children. In addition, the following items were donated to

the Catholic Orphanage in TU DUC: Preserves and jellies, peanut butter, tooth paste and brushes, and assorted children's clothing. Doctor Altomonte made his weekly visit to the Leper Colony at TAN UYEN and treated twenty-five patients. Doctor Altomonte also donated medical supplies to the Bien Hoa Orphanage in an effort to improve the health and sanitation level. Sr/4 Amisano continued his conversational English instruction each day this week to the children of Cong Ly Street and several Bien Hoa National Police.

A/501st Aviation Battalion was active in Refugee Assistance, Transportation, Education, and Community Relations. On 6 April, airmobile elements evacuated 125 refugees from near the Cambodian border to Bien Soi. The refugees, mostly women and children, had been rendered homeless by a search and destroy operation. Transportation was also provided for the Bien Hoa JUSPAO representative, Mr. Martin, in support of psychological warfare activities. The officers and men made the following donations: 1500 pounds of rice to the Catholic Orphanage, and 17,478 piasters to a private Bien Hoa school for the purchase of school supplies. Conversational English classes were conducted for members of the Bien Hoa National Police.



HORST K. JOOST
Lt Colonel, Inf
Commanding

DISTRIBUTION
"D"

HEADQUARTERS
145TH AVIATION BATTALION
APO US Forces, 96227

AVAW-FB

13 April 1966

SUBJECT: Commander's Combat Note
Number 16

TO: See Distribution

VC TUNNELS, FORTIFICATIONS, CAMPS

Information in this report has been compiled from reports from 1st Infantry Division.

Fortifications, base camps, storage areas, and tunnel complexes usually form integrated systems. Size, configuration, and elaborateness vary according to the number of people using the complex, the importance and function of the complex, and the probability of having to defend the complex. Defensive systems usually have tunnels and **trenches for escape** and for shifting defense forces. Sleeping quarters and command posts are centrally located underground. A water supply, either a stream or well, is readily available. Frequently wells are dug in underground rooms or tunnels.

Entrances to underground systems are well camouflaged. Some systems have natural foliage embedded in concrete trap doors. Others use animal mounds or ant hills as entrances. In populated areas, entrances are frequently hidden under fire places, in charcoal kilns, in animal stalls and in storage huts.

Tunnels and underground systems are usually well ventilated. In large tunnels ventilation holes are often the shafts which were dug to help extract dirt during construction. Air **shafts** are quite often filled with bamboo and sticks and other material which forms a porous fill. This allows the air to pass while preventing the shaft to be used as an entrance.

H. K. Joost
HORST K. JOOST
Lt Col - Inf
Commanding











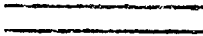



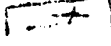

15 Incls
Diagrams of VC Tunnels,
Fortifications and Camps

DISTRIBUTION:
"D"

290

LEGEND

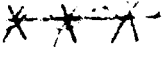
Incl 1

- | | |
|--------------------------------|---|
| 1. TRENCH |  |
| 2. TUNNEL |  |
| 3. BUNKER |  |
| 4. UNDERGROUND SHELTER |  |
| 5. FOOD STORAGE |  |
| 6. BOOBY TRAP |  |
| 7. MINE |  |
| 8. PUNJI PIT |  |
| 9. WELL |  |
| 10. VEGETATION |  |
| 11. EXIT |  |
| 12. TRAP DOOR |  |
| 13. FOX HOLE |  |
| 14. MOUND |  |
| 15. THORN BUSHES |  |
| 16. VINE FENCE |  |
| 17. OBSERVATION/LISTENING POST |  |
| 18. BRIDGE |  |

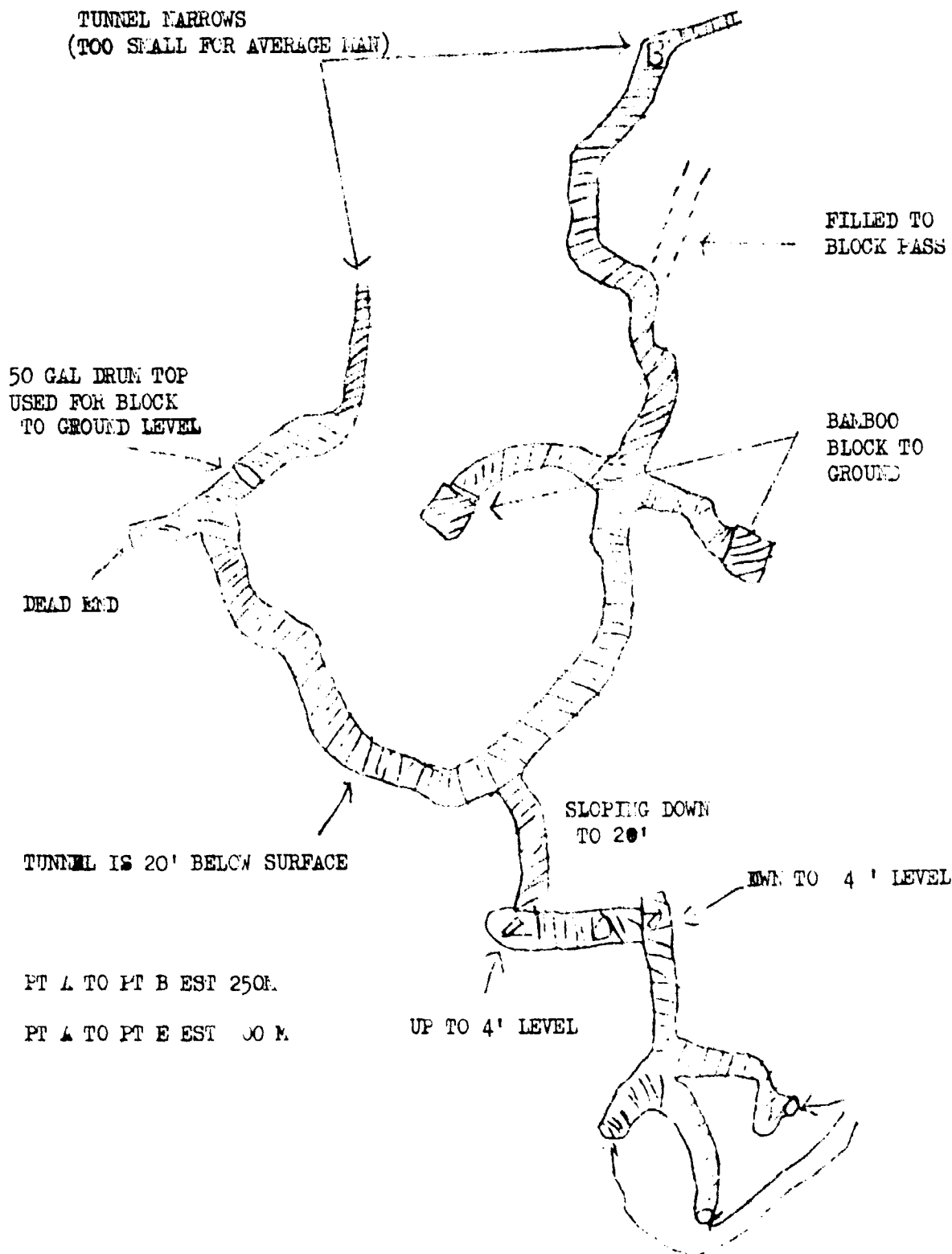

PROFILE OF TUNNEL SYSTEM

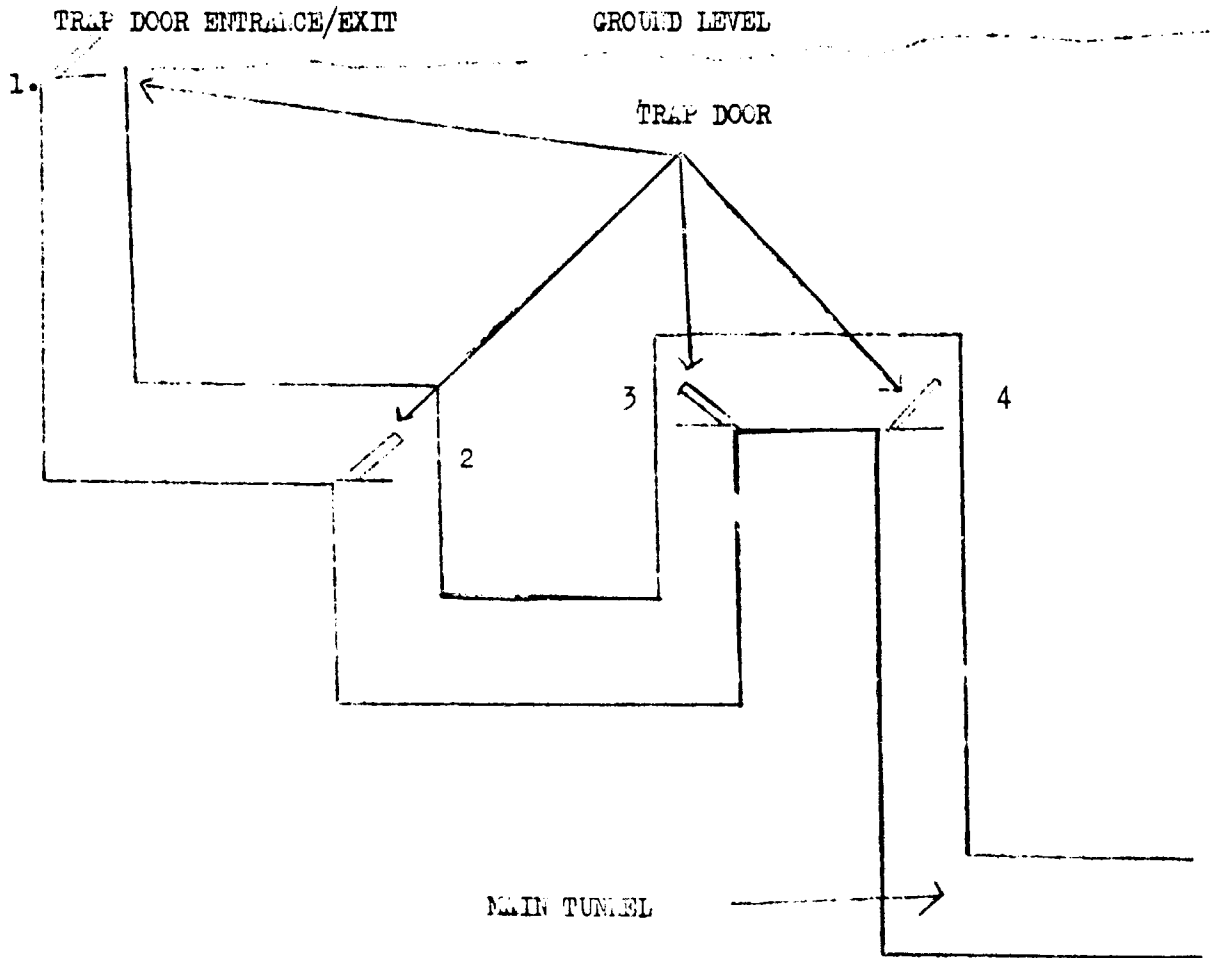

PROFILE OF A TUNNEL SYSTEM

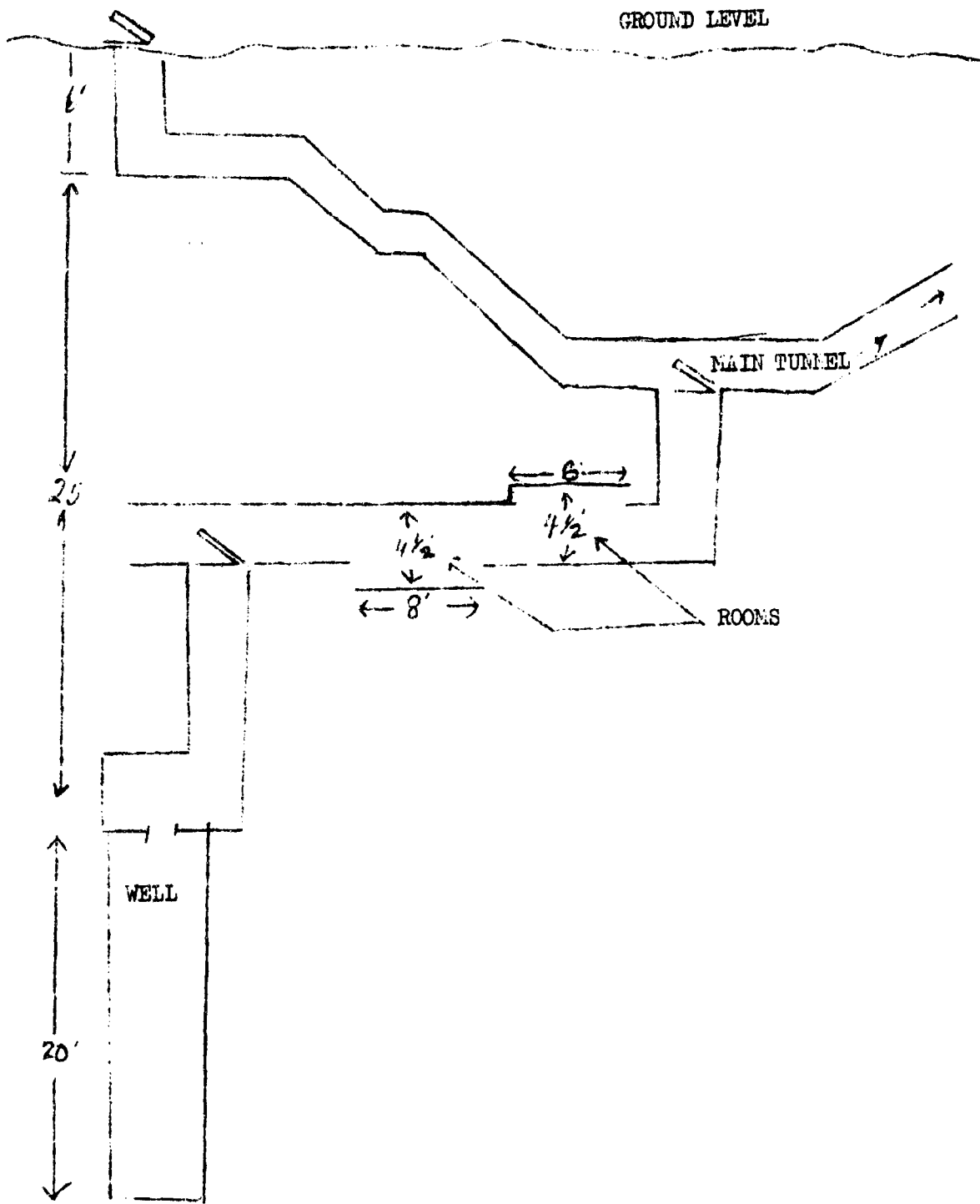

6
294

SIDE VIEW

MAIN TUNNEL

EARTH EXTRACTION SHAFT/
AIR SHAFT

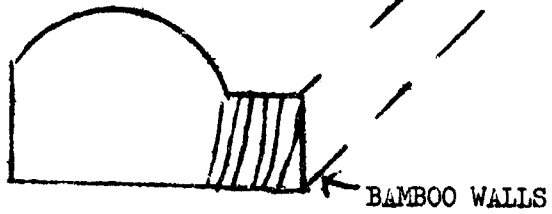

TOP VIEW

MAIN TUNNEL

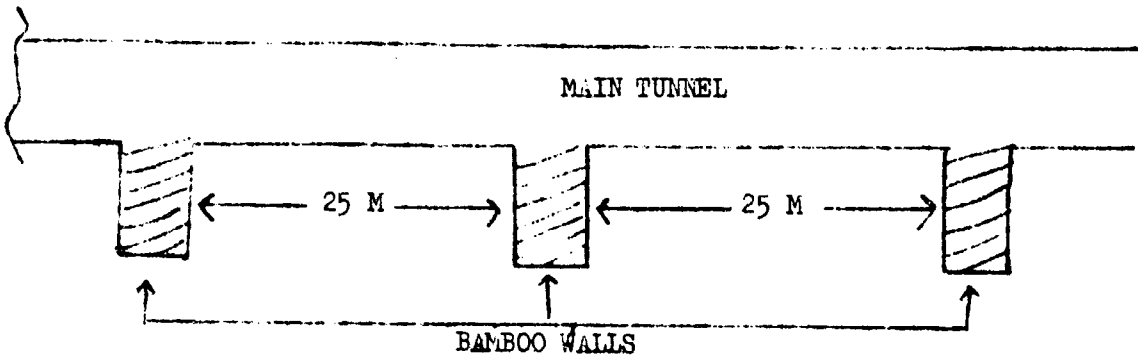

295

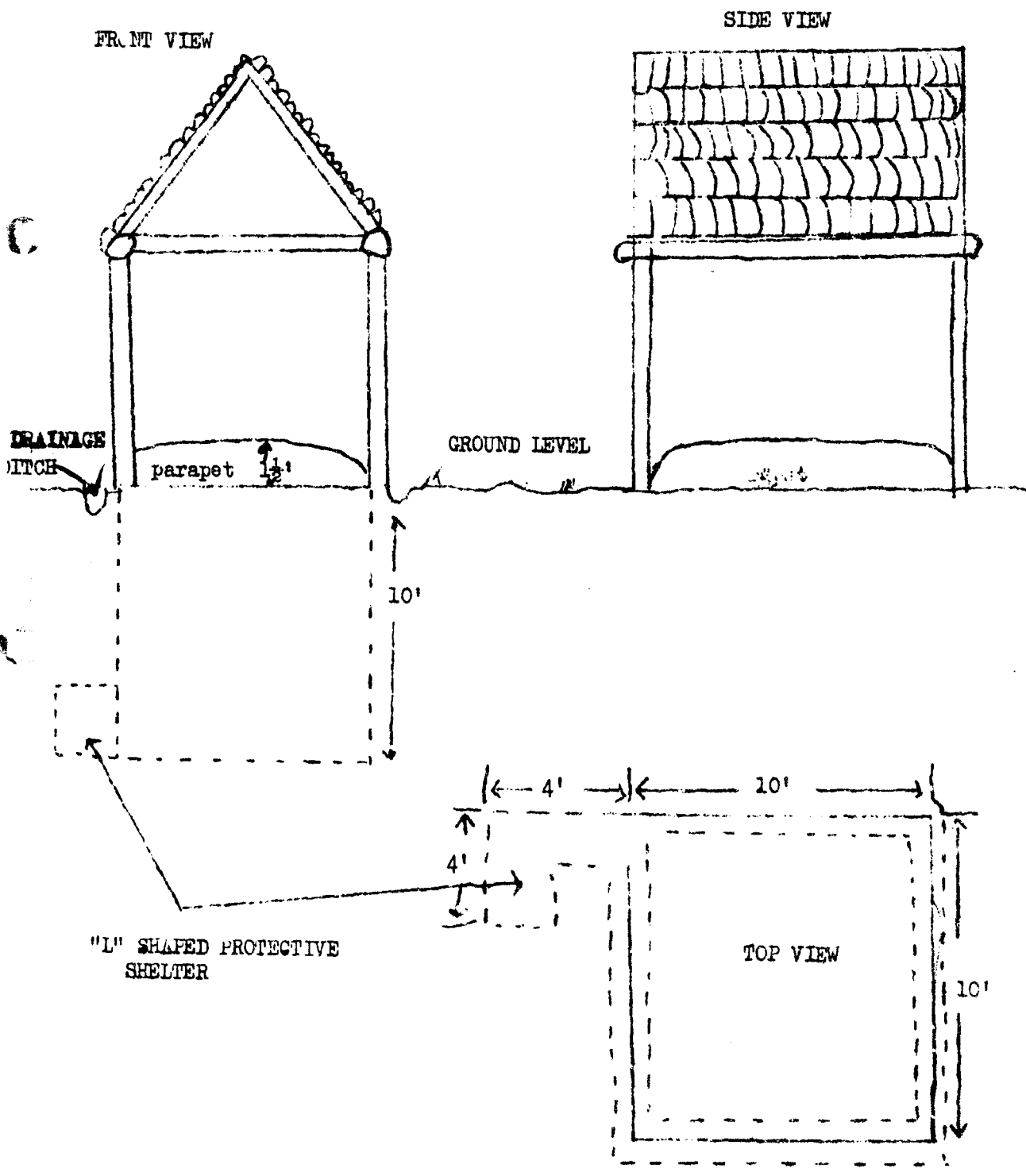

296

BUNKERS

A. COMBAT BUNKER SIDE VIEW

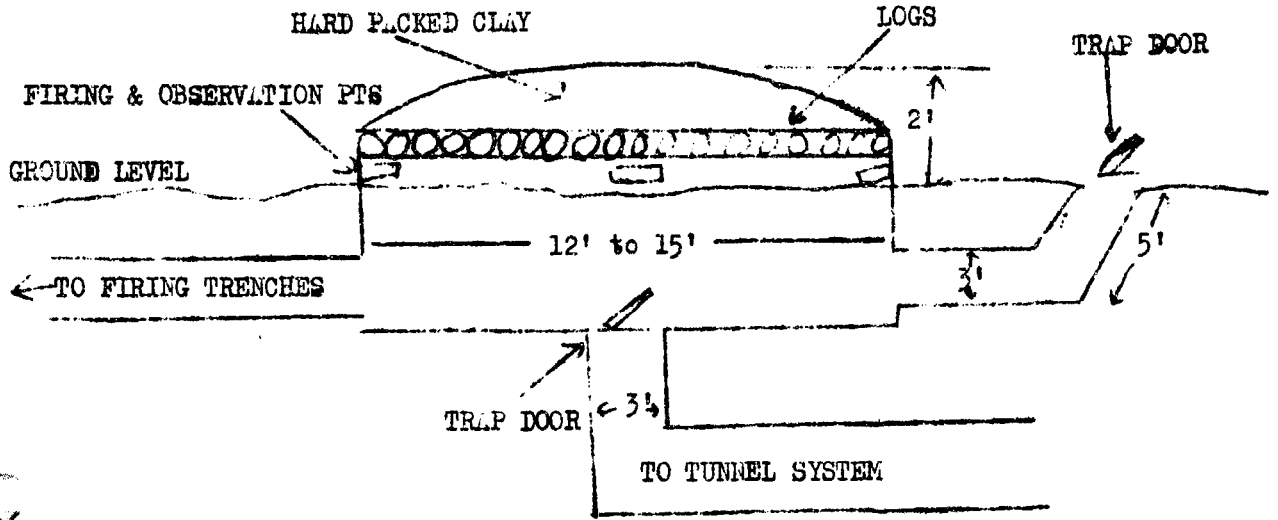

B. OP BUNKER SIDE VIEW

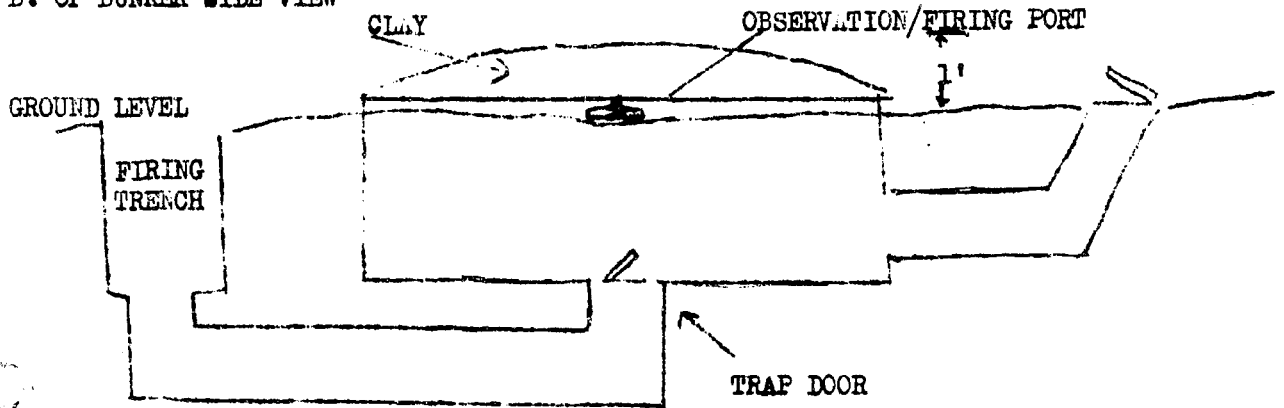

C. COM. D BUNKER SIDE VIEW

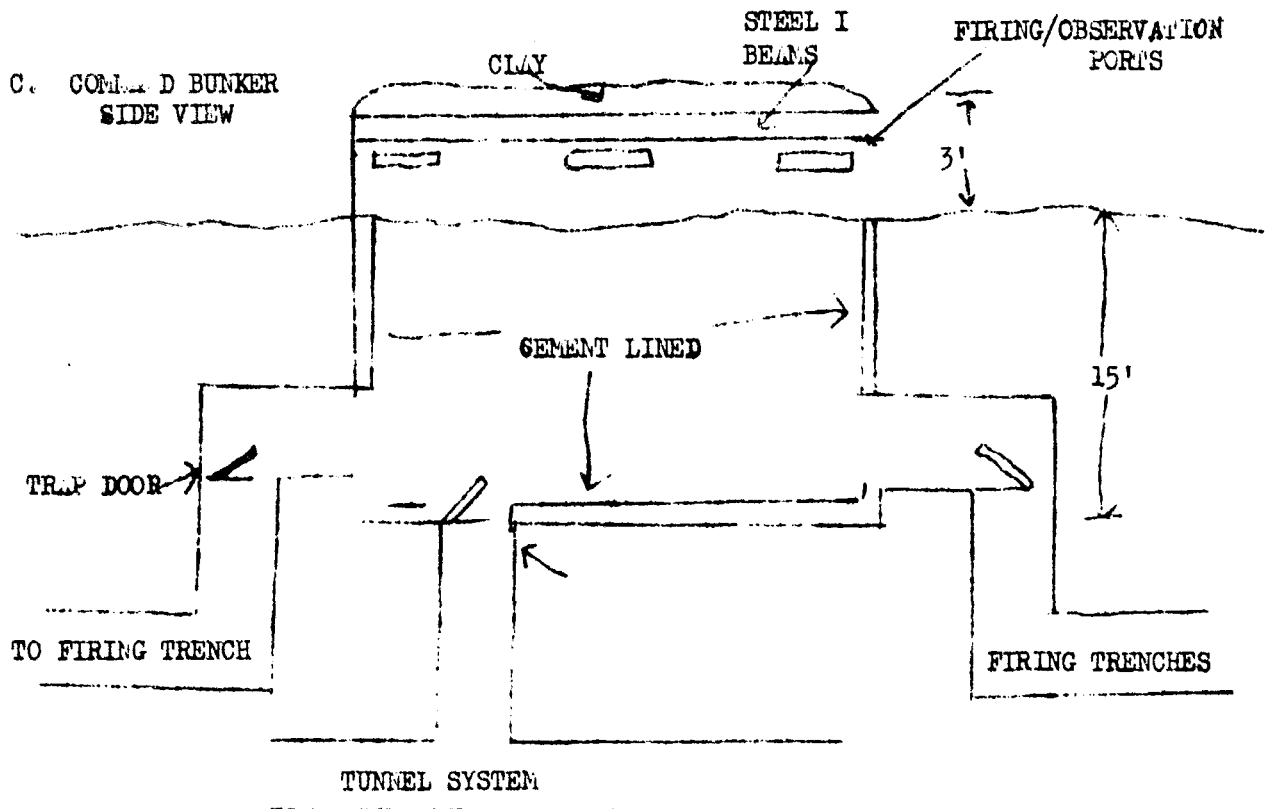

SQUAD SIZE BASE CAMP

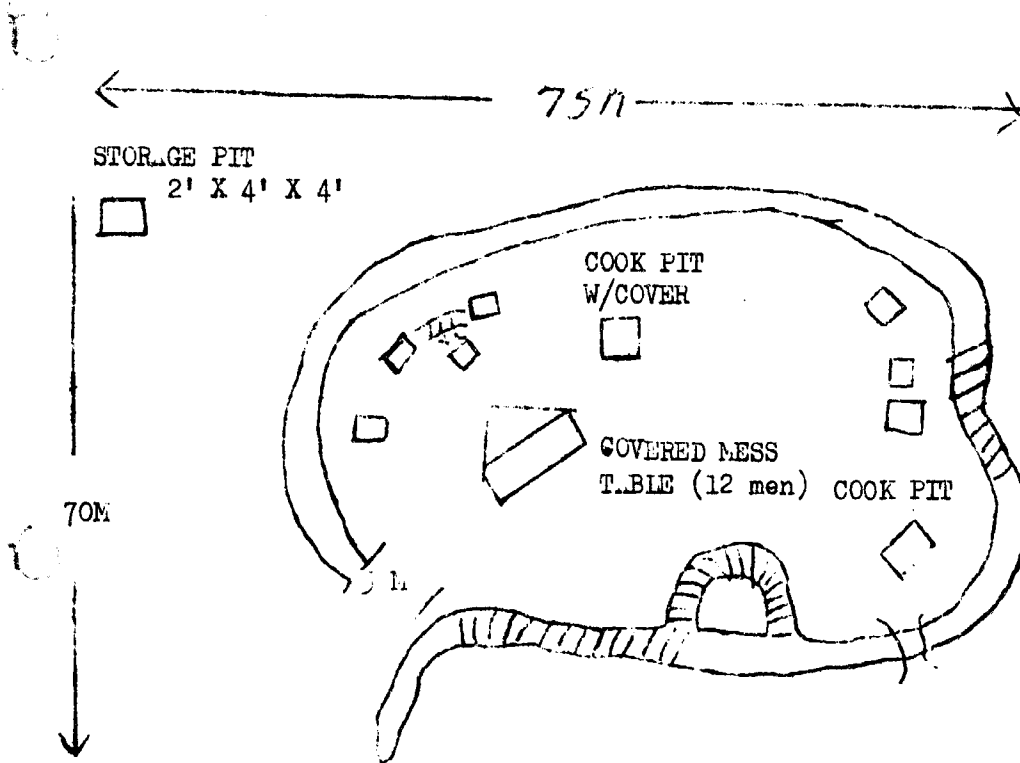

ALL TUNNELS ARE
3' to 6' wide
5' to 6' deep

2298

COMPANY SIZE BASE CAMP

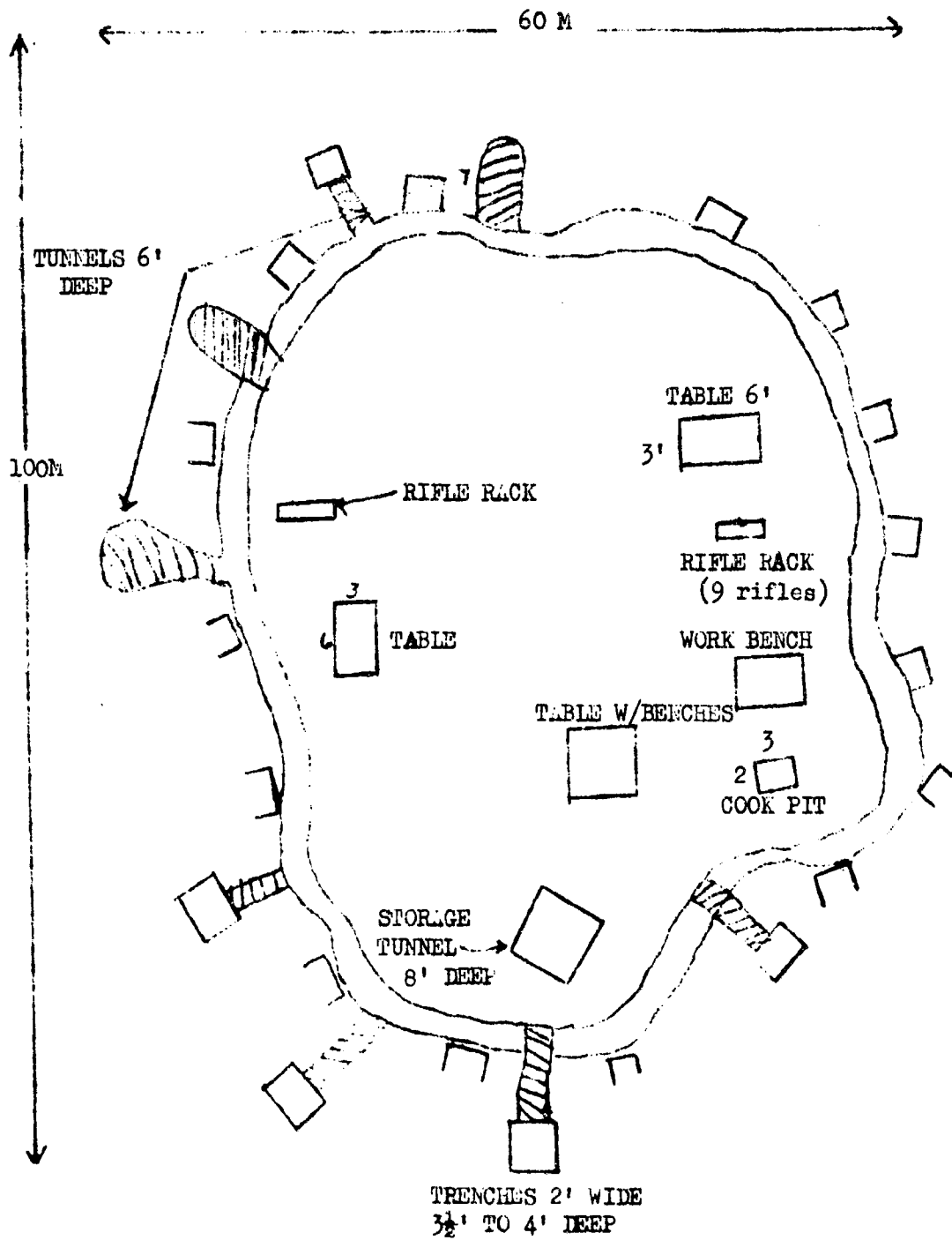

299

TRAILING AREA

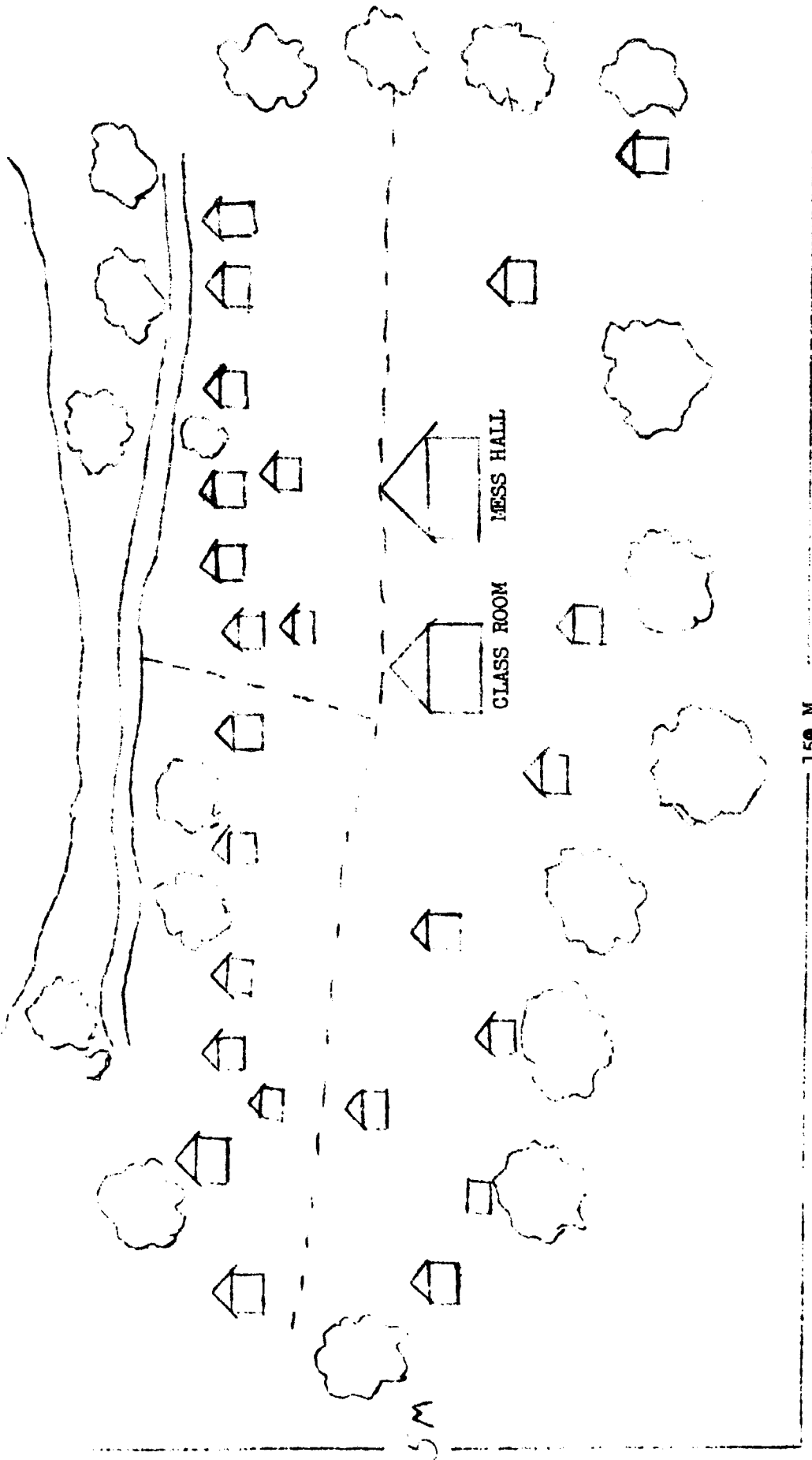

150 M

300

FORTIFIED VILLAGE

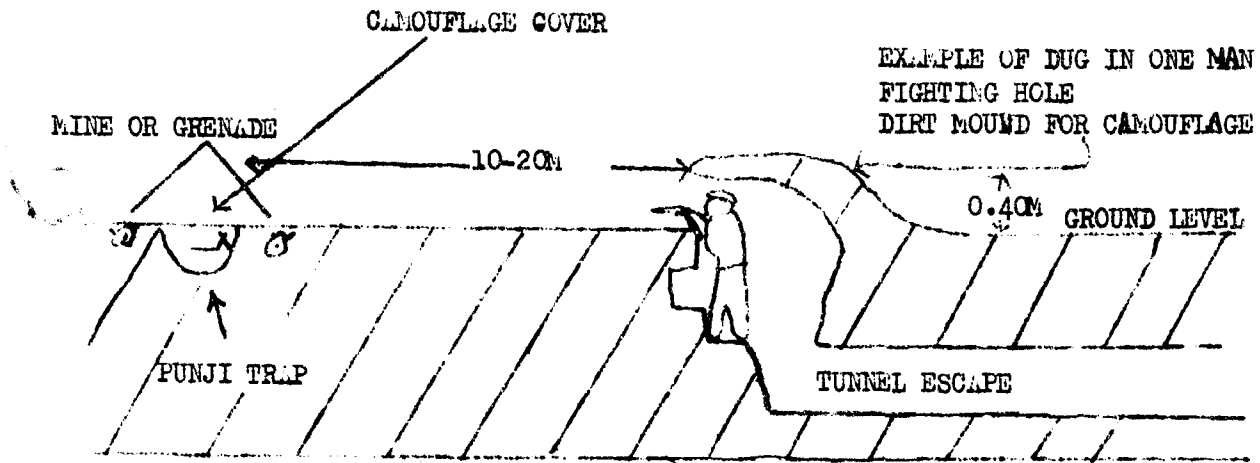

FIGHTING POSITION AS SEEN FROM ABOVE

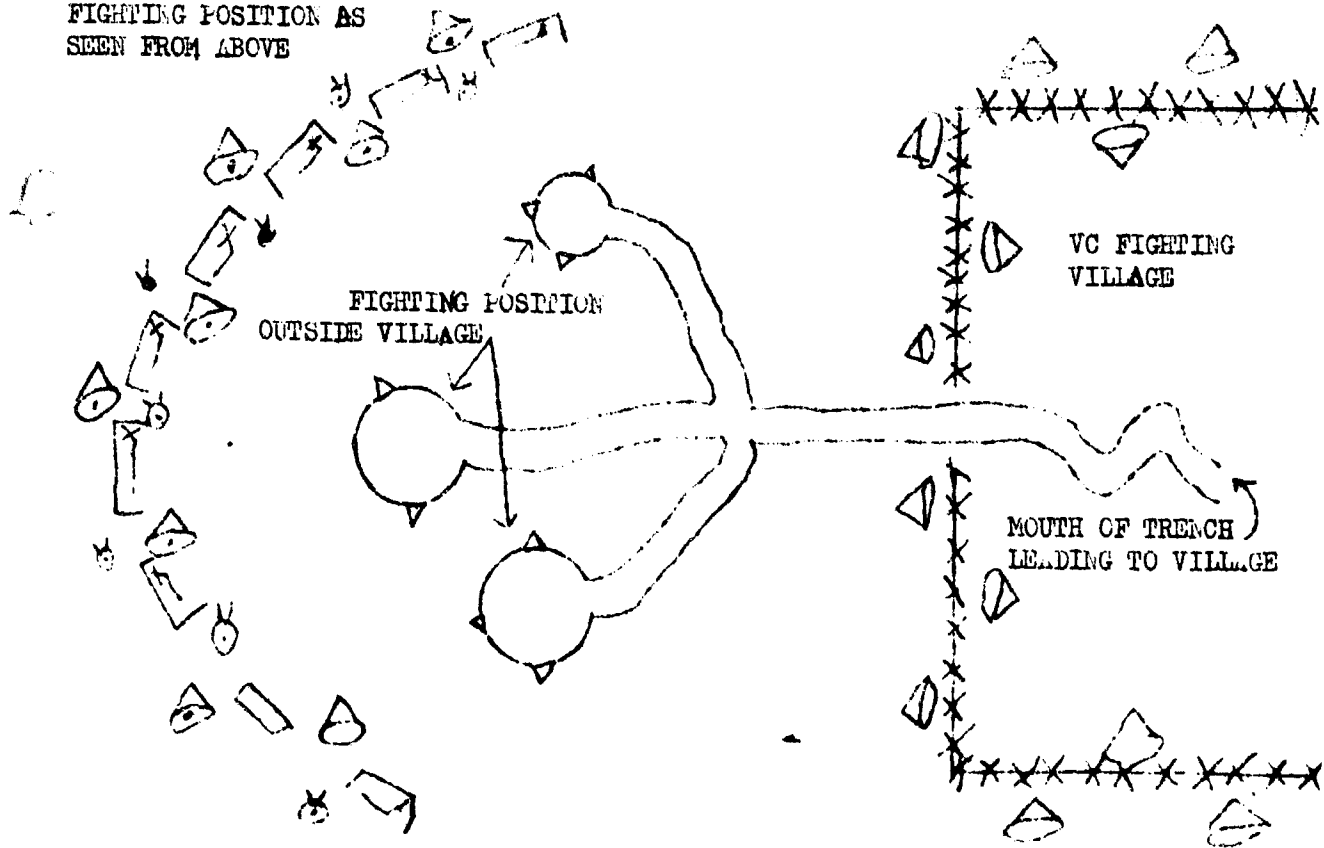

EXAMPLE OF FORTIFIED VILLAGE

x6

301

HEADQUARTERS
145TH AVIATION BATTALION
APO San Francisco, 96227

AVAM-*

16 April 1966

SUBJECT: Commander's Combat Note
Number 17

TO: See Distribution

HELICOPTER TACTICS

1. On a recent operation of the 145th Avn Bn, over a period of five days it became apparent that the VC in the area of Cu Chi were well trained in anti-heliborne tactics. A large number of aircraft were hit and several men were wounded. Most of the aircraft hit were wither on low final approach or had just taken off. The VC have an extensive tunnel system in this area and are well dug in. They also have overhead cover and it is difficult to detect them from the air. In one instance there were three cal .50 MGs within a 6 KM radius in a triangular shape that opened fire on an aircraft at 2500' and continued firing until the aircraft was over 5000'.

2. There are several sound principles which can be followed to reduce the chance of an aircraft being hit. In areas like Cu Chi troop carrier aircraft should never operate at less than 2500 ft unless accompanied by an armed escort. At low level an aviator's best defense is speed. On approaches to the same LZ alter the approach from time to time.

3. The 197th Avn Co has twelve cardinal rules that apply to armed aircraft. Most of them also apply to troop carriers. They are proven as effective tactics.

1. Do not overfly the target.
2. Do not fly in the deadman zone without a reason (100'-1000').
3. Never fly the 180 degree wing position.
4. Always assume that the area is hot.
5. Always make a high reconnaissance.
6. Never fire until you have the friendly forces located.
7. Never fly parallel to terrain features.

8. Avoid firing over the heads of friendly troops.
9. Expend only when you have a worthwhile target.
10. Always know the situation.
11. Take your time.
12. Brief your elements to a man.

4. Commanders, remember, an aviator must be briefed on the tactical situation and his mission to be effective. Detailed coordination with the supported ground unit commander will help to clarify the enemy situation. Use all the protective measures available to you. If gunship escort will increase the probability of mission accomplishment - use it.

Above all, avoid flying over known hostile positions if you can accomplish your mission.

"First In Vietnam"



HORST K. JOOST
Lt Colonel, Inf
Commanding

DISTRIBUTION
"D"

HEADQUARTERS
145TH AVIATION BATTALION
APO San Francisco 96227

AVAW-F

16 April 1966

SUBJECT: Commander's Combat Note
Number 18

TO: See Distribution

SUMMARY OF OPERATIONS 8 APRIL THROUGH 14 APRIL 1966

On Easter Sunday the 145th Aviation Battalion, reinforced by elements of the 11th Aviation Battalion, conducted an airmobile assault, employing 489 troops of MIKE FORCE, III (ARVN) Corps approximately 25 kilometers South of Bien Hoa. The force was landed in three lifts. It was planned to extract the force on the following day, however, at 1445 hours this Battalion was alerted and responded to a rapid reaction request to extract the force immediately. Aviation was recalled from other missions and assembled for the extraction which was completed by 1905 hours.

On 11 April, the Battalion returned to the Ju Chi area to support the 25th (US) Division. A jolly time can always be expected when operating in this area and we were not disappointed. Over 500 troops were employed in an airmobile assault of four lifts ten miles northwest of Cu Chi. No artillery or tactical air preparation was used on the landing zone due to the proximity of a village. As the first elements approached, the gunships marking and reconnoitering received moderate automatic weapons fire. The gunships returned the fire, allowing the troop carriers to land. Light enemy fire persisted throughout the assault with the result of four aircraft being hit. The Battalion's gunships continued to provide close in fire support to the ground elements after the completion of the lift.

For the last two days of the period, the 145th Aviation Battalion supported the 173rd Airborne Brigade in conducting eight airmobile assaults and two extractions in the Song Be area.

The gunships of the 197th Aviation Company again added to the toll of Viet Cong destruction. In one action, gunships responded to a call from an Air Force forward air controller who spotted Viet Cong in the open near Duc Hoa. The gunships engaged with a result of ten confirmed dead Viet Cong. The company's total score for the week is three sampans destroyed and five damaged, five structures destroyed and three damaged, and ten confirmed Viet Cong killed and six estimated killed.

The 74th Aviation Company flew 142 visual reconnaissance and 39 escort missions during the period.

Task Force Seawolf continued to operate from the U.S.S. Belle Grove in support of Naval operations in the Rung Sat Special Zone. Their activities consisted of giving area and aircraft orientation flights to river patrol boat commanders, conducting daylight and night visual reconnaissance of the river areas, conducting airstrikes against Viet Cong targets, and flying cover for patrol boats. On two occasions Task Force Seawolf was instrumental in stopping Viet Cong attacks against friendly villages by repeated firing runs against the besiegers. The total score for the Task Force for this period is one sampan destroyed and two damaged, and two confirmed Viet Cong killed and four estimated killed.

Operational statistics for the period are as follows:

Rotary Wing:

Total Sorties	4440
Total Flying Hours	1640
Passengers	6040

Fixed Wing:

Total Sorties	393
Total Flying Hours	605

Training:

The airmobile companies of the Battalion are conducting in-country orientation briefings and flights to aviators of the 25th (US) Aviation Battalion.

Awards:

The following is a recapitulation of awards received:

	8 April - 14 April	Since 1 January 65
Distinguished Service Cross	0	2
Silver Star	0	15
Legion of Merit	1	3
Distinguished Flying Cross	2	120
Soldiers Medal	0	9
Bronze Star "Valor"	0	26
Bronze Star	1	95
Air Medal "Valor"	4	277
Air Medal	0	9,486

Army Commendation Medal "Valor"	0	50
Army Commendation Medal	8	286
Purple Heart	3	186

* It is worthy of note that these 9,763 Air Medals represent in excess of 375,875 combat flying hours by members of this Battalion! !

SUMMARY OF CIVIC ACTIONS

On 14 April, the HQ & HQ Detachment, 145th Aviation Battalion donated 3000\$VN piasters to purchase school furniture for a self help construction project in the Bui Vinh Parish. In the psy-war effort, thirty pounds of reading material were placed in the community reading room.

The 68th Aviation Company was active in the area of transportation. On 12 April, an airmobile element medically evacuated a wounded child to Bien Hoa Provincial Hospital for immediate medical attention. In addition, the company evacuated or relocated 62 ARVN dependents and refugees and 2500 pounds of personal belongings and foodstuffs in the course of normal missions.

In the area of Community Relations, the officers and men of the 74th Aviation Company donated a case of fresh eggs to Regional Forces dependents on Easter, 500 pounds of clothing collected by the Washington State Highway Patrol to the Duc Hoa Refugee Center, and foodstuffs to an employee with a recent death in his family. 5900\$VN piasters were turned over to the Phu Queng orphanage for the purchase of supplies and materials.

The 118th Aviation Company made significant contributions in the civic actions field in support of 25th Division operations at Cu Chi. Airmobile elements medically evacuated a total of 15 GVN civilians to medical facilities at Trung Lap. In addition, approximately 50 refugees were evacuated from search and destroy areas to the Cu Chi District Headquarters for immediate refugee assistance. The officers and men donated over 1000 pounds of foodstuffs, 9 boxes of assorted clothing and sanitation items to the Bui Vinh Refugee Center, and the Bien Hoa Orphanage. Captain Cooper personally donated 1200 pencils inscribed "From an American Soldier of the 118th Aviation Company", to the Bien Hoa and Bui Vinh School children in a friendship gesture. Sp/4 Amisano conducted English classes for the residents of Cong Ly Street. Doctor Altomonte treated approximately thirty patients and local civilians during his weekly visit to the Tan Uyen Leper Colony. Doctor Altomonte's effort at Tan Uyen were cited by the District Chief as a major contribution in the pacification effort in this Viet Cong influenced area.

The officers and men of the 197th Aviation Company donated 100 pounds of clothing and health and sanitation items to the An Loc Orphanage on Easter Sunday. An armed element of the company branched out in the communications field when it dropped psy-war leaflets in the Run Sat Special Zone at the request of the NHA BE District Chief.

This week, A/501st Aviation Battalion accepted limited sponsorship of the Bui Hiep Refugee Center. In addition, 9 refugees were evacuated in the Ham

4. Tam area by airmobile elements on 11 April. Ten Bien Hoa National Police attended the weekly conversational English class conducted by members of the unit.

Horst K. Joost

HORST K. JOOST
Lt Colonel, Infantry
Commanding

DISTRIBUTION

D

307

HEADQUARTERS
145TH AVIATION BATTALION
APO San Francisco 96227

AVAW-F

23 April 1966

Commander's Combat Note
Number 19

SUMMARY OF OPERATIONS 15 APRIL THROUGH 21 APRIL 1966

Long id need of praise have been a number of aviation activities which are not necessarily glamorous or receive much recognition but which are all important to the mission accomplishment of the 145th Aviation Battalion.

The first of these is the support provided to us during each airmobile operation by Captain Thurman, Operations Officer, 56th Transportation Company, and his aircraft recovery crews. During this month alone he has recovered three downed UH-1D aircraft out of hostile territory. Each recovery has been performed under duress but with such efficiency that in no instance did it interfere or detract from the airmobile mission. Our highest praises to this unit.

Another unsung activity is the constant cover we receive from the 57th Medical Detachment (Air Ambulance) during airmobile operations. They are always overhead when needed. In a recent Battalion operation, one helicopter ambulance received eight hits while evacuating wounded U.S. Forces. They always come back for more.

Our own 74th Aviation Company is constantly aloft to provide radio relay service, weather advisory, visual reconnaissance and air and artillery adjustments during airmobile operations. These aircraft spend many long hours over the objective area. They are the first aircraft over the objective area and usually the last to leave after the operation is completed.

The next activity is that of our Battalion Pathfinder Detachment. This Detachment is commanded by Lieutenant Grover D. Westfall. It precedes the troop carrier aircraft into the pickup site to organize and control troop loading and aircraft landing for pickup. During an extraction, these personnel depart the extraction zone after the last ground elements are airborne.

The 145th Aviation Battalion supports the III (ARVN) Corps with helicopters on a daily basis. Every company in the Battalion receives a turn at this duty. In the performance of this duty aircraft are dispatched throughout the III Corps area, and engage in a variety of missions. Locally we brand these as "Pigs and Rice" missions, the name being derived from the requirement to frequently haul these commodities. These missions are administrative and tactical in nature. An example of some administrative support: This Sunday a helicopter was used to lift Post Exchange supplies

308

and operate as an airmobile PX to fourteen extremely isolated posts which are inaccessible by road in the III Corps area. Religious services are conducted in this manner to isolated posts. Daily mail and courier flights are made to all posts in the three division tactical areas. Helicopters are used to resupply the ARVN forces located on a number of high pinnacles in the Corps area. These outposts exist only by helicopter resupply. Popular forces personnel and occasionally their dependents and belongings are transported to new locations. A helicopter pilot flying these missions cannot allow himself to become shook about what he may see being loaded in his aircraft. Other administrative tasks are to transport advisors to these remote outposts, the only contact they have with the forces at these locations.

The tactical missions for the Corps consist of providing armed helicopter fire teams daily to each of the three ARVN divisions. These teams are used to conduct strikes against Viet Cong locations, provide escort for road convoys and aerial reconnaissance. Psychological warfare loudspeaker missions are flown by troop carrier helicopters, supported by a fire team. These missions can always be counted on to prompt a reaction by fire from the Viet Cong. Another tactical mission is the delivery by helicopter of Reconno Teams. This week, three Reconno Teams were employed by this Battalion into Viet Cong suspect areas. Gunships cover these deliveries.

Daylight and night reconnaissance is made around the Bien Hoa Air Base complex by a fire team. The senior advisor of the Dong Nai area credits this continuous surveillance as a major contributing factor to the security from Viet Cong attack that the Air Base has enjoyed.

Now for the airmobile operations conducted this week.

On 15 April, Company A/501st Aviation Battali supported the 173rd Airborne Brigade by conducting two airmobile assaults and four extractions. A total of 425 troops were lifted in twelve lifts. Enemy ground fire was received in the landing zone.

On 16 April, the 68th Aviation Company, supported the 2d Brigade, 25th (US) Division by airlifting 126 troops in two airmobile assaults, northwest of Cu Chi.

Company A/501st, continued to support the 173d Airborne Brigade, by conducting six airmobile assaults with 333 troops of the First Royal Australian Regiment in the vicinity of Song Be.

On 17 April, A/501st supported the 173d Airborne Brigade by conducting five airmobile assaults and one extraction in the vicinity of Song Be. A total of 367 troops were lifted.

The 145th Aviation Battalion conducted an airmobile operation on 18 April for the 25th (ARVN) Division, ten kilometers Northwest of Tan An. This operation demonstrated some problems in coordination and control when an unscheduled, unannounced and uncontrolled airstrike with White Phosphorous ordnance struck the landing zone immediately prior to the time of the troop

2
309

landing. Aircraft were diverted for forty-five minutes until the smoke in the landing zone dissipated. A total of 510 troops then assaulted four landing zones. During this operation, armed helicopters of the 68th Aviation Company engaged a squad of Viet Cong with a result of three kills estimated.

Company A/501st again supported the 173d Airborne Brigade on 18 April, by conducting ten combat assaults with 563 troops in the Song Be area.

On 20 April, the 145th Aviation Battalion supported III (ARVN) Corps CIDG Forces by airlifting 570 troops in four air assaults out of Song Be to two landing zones thirty kilometers east of Song Be. One highlight of the assault was the first employment of the XM-31 20mm cannon sub-system in a combat operation. The system is currently being tested by the 197th Aviation Company (Armed). It consists of 2 - 20mm cannons which are flexible in elevation, mounted on each side of the UH-1B helicopter. This weapons system was used for the helicopter prestrike of the wooded areas surrounding the landing zone. The assault was uncontested.

Also on this date, the 118th Aviation Company supported the Capitol Military Region by conducting an airmobile assault with 100 troops ten miles southwest of Saigon. Later in the day this force was extracted.

On 21 April, the 68th Aviation Company departed for Vinh Long to reinforce the 13th Aviation Battalion in support of the IV Corps (ARVN) for a three day period.

The activities of the 197th Aviation Company while operating on separate gunship missions accounted for seven Viet Cong estimated KIA, four sampans sunk and two damaged, and seven structures destroyed.

The 74th Aviation Company (FW) performed the following tasks during the period:

Visual Reconnaissance	102
Escort Missions	76
Photo Missions	2

Operation Sea Wolf moved into Phase II this week by assembling armed helicopters and additional crews and support personnel to outfit another naval vessel. Personnel are undergoing training to land on LST decks at this time. Also the U.S.S. Belle Grove is being replaced with another LSD. This Battalion received a message this week from Commander and Captain of the U.S.S. Belle Grove Naval Task Force 116 which praised the Sea Wolf Operation. An extract follows:..."In addition we must doff our hats to the highly capable Army helo pilots who so rapidly integrated into their fire team support role and who so admirably carried out their assignments. Their quick adjustment without any hitch to night and day flying from our helo and super decks was testimony to their outstanding professional competence. Shipmated in every sense of the word their presence will be sorely missed. However we depart secure in the knowledge that fire team support of the river forces will be in the best of hands. Please convey to USMACV and the Commanding Officer 145th

2

310

Aviation Battalion our "well done" to Captain Brofer and his fine crews for a truly superlative performance."

Operational statistics for the week are as follows:

Rotary Wing:

Total Sorties	4332
Total Flying Hours	1480
Personnel Lifted	5803

Fixed Wing:

Total Sorties	402
Total Flying Hours	538

Personnel of the 25th Aviation Battalion continued with their in-country flight training.

Awards received by the Battalion this week:

Distinguished Flying Cross	1
Bronze Star "Valor"	1
Air Medal "Valor"	6
Air Medal	166
Army Commendation MS	4
Purple Heart	1

At a brief ceremony on 19 April 1966, in Bien Hoa, Honour-Smith Compound was dedicated in memory of Lt. Colonel Charles M. Honour Jr., formerly Battalion Commander of the 145th Aviation Battalion, and Captain Albert M. Smith Jr, formerly Battalion Assistant Adjutant.

After Chaplain (Major) Hugh N. Barnes conducted a short memorial service, Brigadier General Robert T. Knowles, Chief of Staff II Field Forces V, and Lt. Colonel Horst K. Joost, Commanding Officer of the 145th Aviation Battalion, unveiled a large sign at the gate of Honour-Smith Compound. Honour-Smith Compound, previously known as Cong-Ly Complex, houses parts of three separate units, II Field Forces V, the 145th Aviation Battalion, and 232d Signal Company.

SUMMARY OF CIVIC ACTIONS

The Headquarters and Headquarters Detachment donated soap to the nearby Refugee Village School.

The 68th Aviation Company re-located 12 refugees, 23 ARVN dependents, and 2600 pounds of personal belongings. A company delegation was sent to the fishing village of Can Gio. The party took along a donation of soap, tooth paste, clothes, toilet articles, school supplies, and miscellaneous items which were obtained by Captain Gore from the American Legion in his home town. Four enlisted members have volunteered to teach English classes and a medical aid program is being planned.

The 74th Aviation Company continued its activities started last week. English classes were taught to children in Phu Cuong. Volunteers aided a Regional Forces Platoon in construction of new living quarters in Phu Cuong. Officers and men donated more condensed milk, fresh milk, canned hams, and orange juice to a local school to supplement the children's diet.

The 118th Aviation Company was active in many areas of civil affairs. Fifty pounds of clothing was gathered and donated by the Officers and Enlisted men of the 118th Aviation Company and distributed to the refugee center at Binh Vinh. Captain Glenn R. Weber donated Vietnamese ice cream cones to the local children at Hung Trung Province while on a joint service operation on 19 April 66. These children were combat refugees and were greatly taken by this act. Sp/4 Amisano conducted conversational English classes for the eighth straight week on Cong-Ly Street. His classes now range to 25 students or more counting the Bien Hoa National Police attending. The Officers of the 118th Aviation Company, contributed donations to the Bien Hoa Orphanage of the following items: Blankets, towels, infant playsuits, toys, soap, tooth paste, talcum powder, tooth brushes, hair brushes, combs, boxes of clothes, adhesive tape, childrens shampoo, boxes of crayons, coloring books, surgical soap, infant shoes, and assorted childrens clothing and a good supply of food stuffs. The Company also made donations of food stuffs and clothing to the Tu Duc Orphanage. Doctor Altomonte made his weekly visit to the Tan Uyen Leper Colony and treated twenty patients and local civilians.

The 197th Aviation Company provided additional support to the An Loc Orphanage in Saigon by donating 1000 pounds of rice and a case of One-a-Day Vitamins.

A/501st Aviation Battalion's Officers donated 6,785\$VN piasters to purchase school furniture for a self help project at Bui Vinh Refugee Center. Three volunteers conducted a two hour conversational English class for forty residents of Tam Hiep. This was followed by another class on 21 April 66 for approximately fifty residents. Six bags of cement and several types of school supplies were donated to Tam Hiep. A USAF Lieutenant was transported to Due Tu for coordination with the District Chief in making a short film about refugees. A new project was begun by making initial contact with Due Tu Sub-Sector Chief and Tam Hiep Hamlet Chief.

DISTRIBUTION:
"D"

Horst K. Joost
HORST K. JOOST
Lt. Colonel, Infantry
Commanding

312

HEADQUARTERS
145TH AVIATION BATTALION
APO US Forces, 96227

AVAW-F

23 April 1966

Commander's Combat Note
Number 20

PERFORMANCE ON GUARD

In the past few weeks there have been two cases in which members of this Battalion fell asleep at their posts while on guard duty. Both of these individuals were tried by Special Courts Martial and received sentences which included six month confinement.

I want every member of this command to be aware of the gravity of the act of sleeping on guard post. A sentry is charged with the security of life and property. He must realize the responsibility entrusted in him and carry out his duties accordingly.

The insidious enemy that confronts us is constantly waiting for us to let down our guard. He strikes at complacency and avoids vigilance.

All members of this command must be imbued with the awareness of the fact that the enemy is constantly seeking to inflict damage to our forces with the object of reducing our combat effectiveness.

Complacency will not be tolerated by any member of this Battalion.

Horst K. Joost
HORST K. JOOST
Lt Col Inf
Commanding

DISTRIBUTION:
"D"

HEADQUARTERS
145TH AVIATION BATTALION
APO US Forces, 96227

AVAW-F

30 April 1966

Commander's Combat Note
Number 21

SUMMARY OF OPERATIONS 22 APRIL THROUGH 28 APRIL 1966

This week I wish to praise the outstanding work performed by our maintenance detachments which have month after month kept the aircraft of this Battalion flying several thousand hours over the program. These units are the 391st Transportation Detachment, supporting the 68th Aviation Company; The 563d Transportation Detachment, supporting the 74th Aviation Company; The 573d Transportation Detachment, supporting the 118th Aviation Company; The 571st Transportation Detachment, supporting the 197th Aviation Company; and the 151st Transportation Detachment, supporting A/501st Aviation Battalion.

During the period the 145th Aviation Battalion conducted one airmobile operation involving all companies of the Battalion. The other operations consisted of companies of this Battalion reinforcing other aviation units, companies operating independently to support ground combat units, and daily III (ARVN) Corps support. The 197th Aviation Company continued to conduct numerous Lightning Bug and other aerial fire support missions, while the 74th Aviation Company provided fixed wing support to U. S. and ARVN Forces in the III Corps area. Operation Sea Wolf continued to strike at the Viet Cong in the Rung Sat Special Zone.

Company A/501st continued their supporting of the 173d Airborne Brigade in the Song Be Area on 22 April, by conducting an assault and a subsequent extraction with 476 troops.

On 23 April, the 68th Aviation Company returned from the IV Corps Area, where they supported the 21st (ARVN) Division for two days. During that time they conducted seven combat assaults and one extraction in the Vi Thanh area. Two aircraft were hit by enemy fire.

This was a busy day for the 118th Aviation Company, conducting two airmobile operations for III (ARVN) Corps. The first operation consisted of airlifting two CIDG Companies, one from Dien Hoa and the other from Dong Xoai to an area thirty kilometers east of Song Be. Also lifted were 90 CIDG dependents. The second operation was initiated by the company when they responded to the requirement to relocate the 9th (ARVN) Regiment to Song Be. In ten lifts the company relocated 1150 troops, the last portion being conducted during the hours of darkness.

The 68th Aviation Company and Company A/501st supported the 1st (US) Infantry Division's operation BIRMINGHAM on 24 April. These companies airlifted 549 troops in five airmobile assaults northwest of Tay Ninh. Enemy ground fire accounted for four aircraft being hit.

The 118th Aviation Company responded to a rapid reaction to support the Capital Military Region by extracting 120 ARVN troops from a site 10 kilometers east of Saigon. In order to respond to this mission it was necessary to recall the aircraft of the company from a variety of tasks and locations within the III Corps area. From alert to mission accomplishment one hour and forty minutes elapsed.

On 26 April, ten armed helicopters of the Battalion flew in support of MACV directed missions. Company A/501st supported the 25th (ARVN) Division by airlifting 96 ranger troops in two combat assaults in the vicinity of Duc Hoa.

On 28 April, the 115th Aviation Battalion supported III (ARVN) Corps' portion of operation BIRMINGHAM, by airlifting 1406 troops of the Airborne (ARVN) Division in four combat assaults thirty kilometers north of Tay Ninh. In a subsequent action, 280 ARVN Rangers were airlifted in one combat assault north of Tay Ninh.

The armed helicopters of the 197th Aviation Company accounted for five sampans sunk and one damaged.

The 74th Aviation Company conducted the following fixed wing missions for the period:

Visual Reconnaissance	85
Escort Missions	77
Radio Relay	16
Artillery Adjustment	86
Forward Air Control	4
Command Liaison	70
Command Staff Liaison	7

The activities of Task Force Sea Wolf for the past two weeks consisted of flying armed aircraft support for river patrol boats in the Rung Sat Special Zone supporting the Nha Be (Headquarters) and Soi Rap-Long Than River Areas. The armed helicopters operate from two naval vessels at this time; they are the LSD Tortuga and the LST Floyd County. The armed aircraft flew a total of 82 hours for the two week period accounting for an estimated 10 Viet Cong killed and two sampans destroyed. On 26 April, the U. S. S. Tortuga was visited by General Westmoreland, COMUSMACV and Admiral Ward, COMNAVFORC, at which time they were able to witness the armed helicopters in action.

The operational statistics for the Battalion are as follows:

Rotary Wing

Total Sorties	4723
Total Flying Hours	1688

315

Total Passengers 6263

Fixed Wing

Total Sorties 400

Total Flying Hours 585

Training

Training in the conduct of night airmobile operations on platoon and company level progressed as operational commitments permitted.

The awards received by members of this Battalion this week are as follows:

Air Medal for Valor 11

Air Medal 144

Purple Heart 8

This week this Battalion was awarded its 10,000th Air Medal since January 1965. The 10,000th Air Medal was awarded to Specialist E-5 James Bryant, (Crewchief) Headquarters and Headquarters Detachment, 145th Aviation Battalion.

CIVIC ACTION

This Battalion should be proud of the dynamic civic action program that it is promoting. Many worthwhile and lasting contributions are being made that are vivid demonstrations of the motives of the United States Forces in Vietnam. Each unit of this Battalion feels a responsibility for a segment of Vietnamese Life and each active participant obtains personal satisfaction that he is doing just a little more than he was expected to do. In transacting all civic action projects through GVN province officials we are assured that the need for assistance is valid and it strengthens the tie of the people to the government. We are thankful for the generous assistance that we have received from a number of wives, families, and organizations in the United States in the form of contributions. I am certain that their efforts are well rewarded by observing the expression of gratitude in the face of a bare-cheeked-behind, Vietnamese youngster receiving a good set of clothes.

On 26 April the Headquarters and Headquarters Detachment, 145th Aviation Battalion donated 2715\$VN piasters to purchase school furniture for the self help construction project at Dui Vinh. In addition, a water truck with driver supported the school construction project for three days. Thirty pounds of clothing received from supporters in the United States were distributed to sixty refugee families in Dui Vinh. Chaplain Barnes distributed approximately 400 pounds of foodstuffs and sanitation items at the Don Bosco Boys school in Saigon.

The 68th Aviation Company was active in the area of transportation. During the week, airmobile elements evacuated and relocated 86 refugees and ARVN dependents and 5000 pounds of foodstuff and household goods.

316

The officers and men of the 74th Aviation Company donated approximately 300 pounds of foodstuffs to the 5th ARVN Division dependents. In addition, the officers donated 3 cases of soap to the children at Thu Dan Mot through the local GVN official. Members of the 4th Platoon accomplished an emergency medical evacuation of a refugee mother and daughter to the Phu Cuong Hospital.

The 118th Aviation Company donated foodstuff, clothing and sanitation items to the orphanage, evacuated refugees at Song Ben and was active in the Health & Sanitation, and Education fields. The officers and men donated 2000 pounds of foodstuffs, and 200 pounds of clothing, cleaning products and medical supplies to the Bien Hoa Orphanage. Sp-4 Amisano conducted conversational English classes for residents of Cong Ly Street. Airmobile elements evacuated 37 refugees on two separate occasions from search and destroy areas to refugee centers at Song Be and Duc Hoa. Doctor Altomonte treated approximately 25 patients on his weekly visit to the Tan Uyen Leper Colony.

The 197th Aviation Company continued its support to the An Loc Orphanage. Thirty pounds of clothing received from supporters in the United States, and two cases of soap were donated to the orphanage. Sp-5 Geary, a medic, gave on the spot medical aid to include a tetanus shot to a Vietnamese National who had stepped on a nail. The officers assisted the orphanage in obtaining water during this critical period by providing a pump and an operter to fill the reservoir at the orphanage.

A/501st Aviation Battalion accomplished a variety of tasks in their support of Bui Hiep refugee center. At the request of the Chief, a truck was provided to transport building material for the self-help school project. Conversational English classes were conducted on the 25th and 28th and as a result of the interest generated, classes will be given four days per week starting 2 May. In addition, airmobile elements evacuated a total of 50 refugees from a search and destroy area west of Tay Ninh.

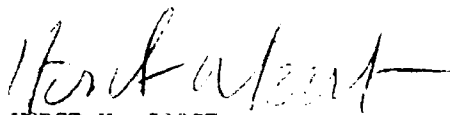

HORST K. JOOST
Lt Col Inf
Commanding

DISTRIBUTION:
"D"

317

HEADQUARTERS
145TH AVIATION BATTALION
APO San Francisco 96227

AVAIL-F

8 May 1966

Commander's Combat Note
Number 22

SUMMARY OF OPERATIONS 29 APRIL THROUGH 5 MAY 1966

This week the 145th Aviation Battalion provided combat aviation support to every major U.S. and ARVN unit located in the III Corps area.

On 29 April, the 118th Aviation Company supported the 1st Infantry Division by airlifting 460 troops in seven combat assaults in the vicinity of Tay Ninh.

The 68th Aviation Company supported the 25th (ARVN) Division by airlifting 210 troops and 15 tons of cargo.

On 30 April, the 145th Aviation Battalion supported III (ARVN) Corps with one airmobile company, the 25th (US) Division with three airmobile companies, and MACV with fifteen armed helicopters. During the operation of these armed helicopters in the Rung Sat Special Zone, a light fire team received enemy fire and retaliated with a strike which resulted in destroying five sampans and damaging one, and killing two Viet Cong. Cargo on sampans destroyed was observed to be web equipment and steel helmets.

On 1 May, the 118th Aviation Company again supported the 1st U.S. Division by extracting 190 troops from a location 30 kilometers north of Tay Ninh. The extraction was contested by the enemy.

In the same general area, the 68th Aviation Company supported the 25th (ARVN) Division by repositioning troops and supplies.

The 197th Aviation Company, performing a mission in the Rung Sat Special Zone, sank two sampans, destroyed one Viet Cong structure and damaged four others. Operating for the 5th (ARVN) Division, another light fire team of the company destroyed 25 Viet Cong structures which resulted in achieving large secondary explosions. During this strike the fire team leader overheard a radio transmission from Special Forces troops operating in the vicinity, stating that their supply of food, water, and ammunition was exhausted. The team leader having finished his assigned mission, diverted his gunship to haul 3000 pounds of supplies to this force. Results: Another aviation mission accomplished, and a ground combat element rendered combat effective.

On 2 May 66, the 118th Aviation Company again operated in the Tay Ninh area in support of the 1st (US) Infantry Division by extracting 390 troops in six lifts. Enemy small arms fire was encountered during the extraction.

The 68th Aviation Company supported the 25th (ARVN) Division in the Tay Ninh area, by repositioning 164 troops and 23 tons of cargo.

On 3 May, the 145th Aviation Battalion employed one aviation company in support of the III (ARVN) Corps administrative and supply missions, one company in support of the 25th (ARVN) Division, and one company in support of the 25th (US) Division.

The largest operation of the week was conducted on 4 May, when the Battalion, reinforced by Company A/82 Aviation Battalion supported the 173rd Airborne Brigade in the conduct of an airmobile assault in War Zone D, northwest of Tan Uyen. Two airborne infantry battalions of 1382 troops assaulted three landing zones in seven lifts. Although all three LZ's were heavily prepared by artillery, tactical air and armed helicopters prior to the landing, enemy small arms fire was received during the assault landing.

On 5 May, two airmobile companies supported III (ARVN) Corps missions, and one company remained on alert to support the tactical needs of the 173d Airborne Brigade.

The 197th Aviation Company had a full day by providing five light fire teams and one heavy fire team to support MACV requirements, and one light fire team in support of the 10th (ARVN) Division.

During the week, Company A/501st Aviation Battalion provided the bulk of the III (ARVN) Corps administrative and supply support.

The scoreboard of damage inflicted on the enemy this week by the 197th Aviation Company shows: fourteen sampans destroyed and three damaged; twenty-six structures destroyed and four damaged; and five Viet Cong killed by air.

Certain damage was inflicted on the enemy from the gunships of other companies and from the offensive fire technique during assault landings, however, the extent of this damage cannot be verified.

The 74th Aviation Company (fixed wing) missions performed during the week were:

Visual Reconnaissance	38
Escort	23
Radio Relay	3
Artillery Adjustment	43
Forward Air Control	2
Command Support Liaison	3
Command Liaison	45
Combat Observation	20

2:19

Operation Sea Wolf

Captain Charles R. Williams has replaced Captain Brofer as Commander of Task Force Sea Wolf. Captain Brofer will be leaving soon on rotation. I wish to commend him for his outstanding efforts in organizing the Task Force and creating an effective combat aviation unit that is providing aerial fire support for the U. S. Navy.

The operations of the Task Force this week in the Rung Sat Special Zone consisted of providing aerial reconnaissance; medical evacuation; overhead cover for naval swift boats; strikes against Viet Cong concentrations, sampans and installations.

The scoreboard for the week is:

Possible Viet Cong KFA	18
Sampans Destroyed	2
Structures Destroyed	2
Structures Damaged	2

The operational statistics for aircraft performance for the Battalion this week are as follows:

Rotary Wing

Total Sorties	3705
Total Flying Hours	1128
Total Passengers	3896

Fixed Wing

Total Sorties	193
Total Flying Hours	280

Training

Training in the firing of the 20mm weapons system continues. The 197th Aviation Company is training in conjunction with Air Force forward air controllers in the use of night vision devices for detecting targets and developing techniques and procedures for engaging targets at night. The Battalion Pathfinder Detachment is training with the glide slope device to develop techniques aimed at improving the Battalions' capabilities to conduct night airmobile assaults.

The officers and men of the 68th Aviation Company donated clothing, soap and school supplies to Can Gio. Airmobile elements of the company evacuated 40 refugees and ARVN dependants, and airlifted 1500 pounds of personal belongings and foodstuffs on two separate operations.

The 74th Aviation Company gave two baskets of flowers for a memorial service to the Phu Cuong hospital. The officers and men donated 220 pounds of foodstuffs to the widows of the 5th ARVN Division Dependents and 500 pounds to the Phu Cuong Orphanage.

The officers and men of the 118th Aviation Company donated 600 pounds of foodstuffs and a variety of childrens clothing (200) pounds to the Bien Hoa Orphanage. While on an operational mission with the 1st Infantry Division, the company mess fed 100 children A rations for a two day period. The children had been displaced as a result of search and destroy operations and were awaiting relocation assistance. Doctor Altomonte treated 25 patients at the Tan Uyen Leper Colony. In addition, two officers accompanied Doctor Altomonte on his visit and distributed food and clothing to the patients. Sp/4 Amisano initiated another class of conversational English for the residents of Cong-Ly Street. Airmobile elements evacuated 25 refugees and 2100 pounds of personal belongings from an outlying area to Xuan Loc. USOM Relief Supplies were also airlifted from Duc Hoa to the Cu Chi area for refugee assistance.

The 197th Aviation Company continued their support of the An Lac Orphanage in Saigon and expanded their program to include the An Lac Orphanage Farm in Bien Hoa Province. 700 pounds of foodstuffs were donated to the farm, and 4500 Wampmasters were donated to the orphanage in Saigon. A water pump and operator were provided to the An Lac farm which pumped over 3000 gallons of water to allow showers and other hygiene measures, the first in several months. Doctor Balette initiated a medical program that provided assistance for 583 Nationals. Accompanied by two Air Force doctors he drove to Vinh Long, where they examined and treated over 200 Vietnamese of all ages. On 1 May Doctor Balette examined each child at the An Lac farm. On 3 May he returned with two nurses from the 93rd Evacuation Hospital and treated 183 children. On 4 May Doctor Balette spent the afternoon at the An Lac Orphanage in Saigon where he treated over 200 children.

A/501st Aviation Battalion conducted four (4) two (2) hour conversational English classes for the residents of Qui Hiep. The class consisted of approximately fifty (50) students each. Airmobile elements evacuated 28 refugees from operational areas.

Horst K. Joost

HORST K. JOOST
1st Colonel, Infantry
Commanding

DISTRIBUTION:
"D"

The total flying hours for the units of this Battalion for the month of April are as follows:

68th Aviation Company	1948
118th Aviation Company	2167
197th Aviation Company	1573
A/501st Aviation Battalion	1595
74th Aviation Company	<u>2540</u> 9823

It is of interest to note that this total represents 2153 hours flown over the program.

Awards and Decorations:

The highlights of the awards and decorations received this week were sixteen Vietnamese Crosses of Gallantry which were presented by Major General Lulan, Commanding General of the 10th (ARVN) Division, to members of the 197th Aviation Company. Eight of the medals were with Silver Star, and eight with Bronze Star devices. The awards were presented for the actions of two light fire teams on 22 February 1966, conducting repeated strikes against the enemy in support of ARVN ground operations near Tanh-Linh, Bin-Tuy Province.

Special recognition is given this week to all the signal detachments of this Battalion. Communications are the life blood of airmobile operations and all aviation activity. The avionics maintenance personnel are a vital cog in ability for each unit to function effectively. Each of these units has performed with exceptional distinctions:

282nd Signal Detachment

320th Signal Detachment

198th Signal Detachment

94th Signal Detachment

Keep up the good work.

CIVIC ACTION

On 5 May the Headquarters and Headquarters Detachment, 145th Aviation Battalion donated 2000\$VN piasters to provide elementary school fees for approximately sixty (60) refugee children for the month of May. In addition, transportation was provided for the Duc Tu District Vietnamese Information Service Representative who visited an outlying area for the purpose of psychological warfare activities and to deliver 400 pounds of relief supplies.