

UNCLASSIFIED

AD NUMBER

AD396859

CLASSIFICATION CHANGES

TO: unclassified

FROM: restricted

LIMITATION CHANGES

TO:  
Approved for public release, distribution unlimited

FROM:  
Distribution authorized to DoD and DoD contractors only; Foreign Government Information; FEB 1966. Other requests shall be referred to British Embassy, 3100 Massachusetts Avenue, NW, Washington, DC 20008.

AUTHORITY

DSTL, AVIA 6/21621, 17 Nov 2008; DSTL, AVIA 6/21621, 17 Nov 2008

THIS PAGE IS UNCLASSIFIED

**CONFIDENTIAL**  
MODIFIED HANDLING AUTHORIZED

AD 396859

**DEFENSE DOCUMENTATION CENTER**

FOR

**SCIENTIFIC AND TECHNICAL INFORMATION**

CAMERON STATION, ALEXANDRIA, VIRGINIA



**CONFIDENTIAL**  
MODIFIED HANDLING AUTHORIZED

NOTICE: When government or other drawings, specifications or other data are used for any purpose other than in connection with a definitely related government procurement operation, the U. S. Government thereby incurs no responsibility, nor any obligation whatsoever; and the fact that the Government may have formulated, furnished, or in any way supplied the said drawings, specifications, or other data is not to be regarded by implication or otherwise as in any manner licensing the holder or any other person or corporation, or conveying any rights or permission to manufacture, use or sell any patented invention that may in any way be related thereto.

NOTICE:

THIS DOCUMENT CONTAINS INFORMATION  
AFFECTING THE NATIONAL DEFENSE OF  
THE UNITED STATES WITHIN THE MEAN-  
ING OF THE ESPIONAGE LAWS, TITLE 18,  
U.S.C., SECTIONS 793 and 794. THE  
TRANSMISSION OR THE REVELATION OF  
ITS CONTENTS IN ANY MANNER TO AN  
UNAUTHORIZED PERSON IS PROHIBITED  
BY LAW.

UNANNOUNCED

U.S. CONFIDENTIAL-MODIFIED HANDLING AUTH  
U.K. RESTRICTED

~~RESTRICTED~~  
EXCLUDED FROM AUTOMATIC RECORDING  
DOD DIR 5200.10 DOES NOT APPLY

TR 66051

FEBRUARY

1966



ROYAL AIRCRAFT ESTABLISHMENT

TECHNICAL REPORT No. 66051

48

# BLACK KNIGHT

## INSTRUMENTATION SYSTEMS

### PART 2 HEAD AND SECOND-STAGE INSTRUMENTATION

by

D. I. Dawton

F. R. Knott

A. P. Waterfall

DDC

JUL 27 1966

MINISTRY OF AVIATION  
FARNBOROUGH HANTS

U.S. CONFIDENTIAL-MODIFIED HANDLING AUTH  
U.K. RESTRICTED

~~RESTRICTED~~  
EXCLUDED FROM AUTOMATIC RECORDING  
DOD DIR 5200.10 DOES NOT APPLY

396859

396859

DDC FILE COPY

ACCESSION No	
CPSTI	WHITE SECTION <input type="checkbox"/>
DDC	BUFF SECTION <input checked="" type="checkbox"/>
UNANNOUNCED	
JUSTIFICATION	
BY	
DISTRIBUTION/AVAILABILITY CODES	
DIST.	AVAIL. and/or SPECIAL
12	



MINISTRY OF AVIATION

THIS DOCUMENT IS THE PROPERTY OF H.M. GOVERNMENT AND  
ATTENTION IS CALLED TO THE PENALTIES ATTACHING TO  
ANY INFRINGEMENT OF THE OFFICIAL SECRETS ACTS, 1911-1939

It is intended for the use of the recipients only, and for communication to such officers under him as may require to be acquainted with its contents in the course of their duties. The officers exercising this power of communication are responsible that such information is imparted with due caution and reserve. Any person other than the authorised holder, upon obtaining possession of this document, by finding or otherwise, should forward it, together with his name and address, in a closed envelope to:-

THE SECRETARY, MINISTRY OF AVIATION, LONDON, W.C.2

Letter postage need not be prepaid, other postage will be refunded. All persons are hereby warned that the unauthorised retention or destruction of this document is an offence against the Official Secrets Acts.

RESTRICTED

U.D.C. No. 629.19.05 : 629.192.2

ROYAL AIRCRAFT ESTABLISHMENT

① Technical Report, ~~Number~~

⑪ February 1966, ⑫ 52p

⑦ ~~BLACK KNIGHT INSTRUMENTATION SYSTEMS~~

~~PART 2, HEAD AND SECOND-STAGE INSTRUMENTATION~~ [C-11HA], ⑧

⑬ D.I. Dawton, F.R. Knott  
A.P. Waterfall,

⑭ TR-66051

SUMMARY

Instrumentation systems used in the heads and second-stage assemblies fitted to Black Knight test vehicles are described in this Report and some information is given on optical tracking aids employed during re-entry of the heads into the atmosphere.

(310450)

"This document contains information affecting the National Defense of the United States within the meaning of the Espionage Laws, Title 18, U. S. C., Sections 793 and 794. Its transmission or the revelation of its contents in any manner to an unauthorized person is prohibited by law."

Departmental Ref: Space.136

RESTRICTED

CONTENTSPage

1	INTRODUCTION	3
2	DATA HANDLING SYSTEMS	3
	2.1 Telemetry systems	4
	2.2 Tape recorder systems	4
3	TRANSDUCERS	9
	3.1 Pressure and acceleration transducers	10
	3.2 Vibration measurement	11
	3.3 Temperature measurement	11
	3.4 Rate-gyroscope installation	14
	3.5 Erosion gauges	15
4	OTHER INSTRUMENTATION	18
	4.1 Second-stage ignition equipment	18
	4.2 Time delay unit	18
	4.3 Time correlation unit	19
	4.4 Flash unit and detector	20
5	CONCLUSIONS	21
	Acknowledgements	21
	Table 1 Summary of recorders and sub-assemblies used in tape recorder data handling systems	22
	References	23
	Illustrations	Figures 1-29
	Detachable abstract cards	

## 1 INTRODUCTION

It is intended that this report should be read in conjunction with another<sup>2</sup> in which the instrumentation systems used in the main body of Black Knight test vehicles<sup>1</sup> are described. Instrumentation techniques developed for re-entry heads and second-stage assemblies fitted to these rockets are given in this Report.

Volume and weight limitations did not present a serious problem in the case of equipment installed in heads carried by single-stage vehicles (Fig.1(a)) but the introduction of the two-stage rocket (Fig.1(b)) with its smaller re-entry head necessitated the development of a compact instrumentation package.

The requirement for uninterrupted data from heads during the critical re-entry phase also posed many unique problems which were not eased by the varied types of head used for these experiments, the wide range of re-entry velocities and the fact that external aeri-als should not affect the motion of the head during re-entry into the atmosphere.

## 2 DATA HANDLING SYSTEMS

Design considerations for the head data handling system indicated that for re-entry velocities in excess of 13000 ft/sec (approx) there could be severe signal attenuation due to the ionisation of ablation products caused by the effect of kinetic heating and surface erosion. Signal fading would be most severe at the particular time during re-entry when heat transfer data etc, would be most valuable. Since Black Knight is fired over a land range (Woomera range, W.R.E., Australia) and component recovery is possible it was considered that the data should be recorded in the head and recovered after impact. The design of a range of tape recorders was therefore initiated in Instrumentation Dept (Now I and R Dept) R.A.E., with the close co-operation of the Black Knight group and a number of versatile instrumentation packages were ultimately produced (see Section 2.2).

Until the development of a tape recorder system had been completed, non-separating heads (H.01 and H.02) and separating heads (H.03, H.05, and H.11) for preliminary investigations at relatively low re-entry velocities (up to 11750 ft/sec) were fitted with telemetry transmitters. Recoverable tape recorders have been used in two heads (H.06 and H.14) carried by single-stage vehicles and in the later heads fitted to two-stage vehicles (re-entry velocity approximately 16000 ft/sec).

## 2.1 Telemetry systems

To provide adequate signal strength so that the ground receiver aerials could track throughout flight and during re-entry a modified version of the 465 Mc/s R.A.E. sub-miniature telemetry transmitter (mean power output 6.5 watts) was installed in the early separating heads. The sender was similar to the main body unit<sup>3</sup> (Fig.2) except for modified voltage sub-commutation and accelerometer fittings. The voltage range used to modulate the transmitter was also modified so that an input of 0 to +3 volts gave sub-carrier frequencies of 160 to 130 Kc/s.

A special monopole aerial was developed by Radio Dept, R.A.E., to prevent significant corona loss and to provide a symmetrical drag shape. An aerial of this type was fitted at the centre of the base dome of each head and it was intended to remain clear of any ionised wake from the surface of the head during re-entry. Extensive polar diagram checks indicated that the chosen arrangement provided adequate signal strength at the range-head telemetry receivers in the absence of any ionisation effects. A photograph of a complete re-entry head showing the monopole aerial is given in Fig.3. (Head H.11, of the head shield type, fitted to B.K.07.) The system proved satisfactory in practice and extremely good telemetry records were obtained during the re-entry phase. Before separation from the main body (Fig.1(a)) the head aerial was capacitively coupled to a slave aerial<sup>2</sup> fitted to the instrumentation compartment so that a signal could be received during pre-flight checks on the launcher and during ascent.

Although telemetry was not used as the principal data handling system in heads carried by two-stage vehicles, one of these heads (H2/03 on B.K.17) was fitted with an experimental single-channel telemetry sender (mean power output 2 watts) as an aid to re-entry tracking and it was used to monitor centrifugal acceleration. A slot aerial designed by Radio Dept, R.A.E. was fitted in the base dome of this re-entry head and it was shown possible to obtain a satisfactory polar diagram in the forward direction. Fig.4 shows a photograph of the aerial in the base dome, taken before the duresstos base cap was fitted into position. The design and installation of these aerial systems produced many problems and strengthened the decision to use magnetic tape recording in experimental heads fitted to Black Knight vehicles.

## 2.2 Tape recorder systems

Details of the tape recorder systems used in re-entry heads are available in a series of specifications issued by I and R Dept, R.A.E., but a brief summary of the main features is included in this section.

The recording heads and tape transport systems of all the recorders provide eight channels of information on half inch magnetic tape. A range of transistorised units are used to energise the recording heads and provide the power supply for the tape recorder motors. The units needed for any particular installation depend on the recording method to be used, the nature of the data, and the recording time required. Three methods have been used and these are given below together with notes on the recorders and a typical re-entry head installation.

(a) Recording methods

(i) Direct recording

This method is used where high frequencies (up to 10 Kc/s) are to be recorded but where amplitude accuracy on replay is not required better than  $\pm 20\%$  of full scale deflection. Timing pulses and vibration measurements are included in this category and when vibration is recorded the linearity of the system is improved by using a bias oscillator. This is included in a combined amplifier/oscillator unit (Type IT 2-2-51 Fig.5) which energises the recording head and is connected to the output from the pre-amplifier associated with the piezo-electric pick-off.

(ii) Frequency modulation

An amplitude accuracy on replay of better than  $\pm 1\%$  can be achieved with an FM system if two basic principles are applied:

- (a) The difference between tape speeds during recording and replay must be negligible.
- (b) Calibration voltages must be recorded.

The former is achieved by care in the design of the recorder and by using flutter compensation and speed control on replay. A stable timing signal must be recorded on the tape with the data for this purpose.

Frequency modulator type IT-1-5-57 (Fig.5) requires an input voltage of 0 to +5 volts and the centre frequency and frequency deviation can be adjusted to suit the tape speed. A recommended relation between recording speed, FM bandwidth, signal bandwidth, maximum sampling rate and switch

speed (see Note (i)) is given below. Acceleration, pressure, temperature, pitch and yaw rates etc, which do not usually vary at frequencies greater than 20 c/s are recorded on FM channels which are time-division multiplexed.

Recording speed in/sec	Timing frequency Kc/s	FM bandwidth c/s	Signal bandwidth c/s	Maximum sampling rate samples/sec	Switch speed rev/sec
$7\frac{1}{2}$	10	3600 to 8400	0 to 1000	300	12
$3\frac{3}{4}$	5	1800 to 4200	0 to 500	150	6
$1\frac{7}{8}$	2.5	900 to 2100	0 to 250	75	3

(iii) Carrier erase

In this system a constant amplitude carrier signal (see Note (ii)) is recorded on the tape before use. During the recording process the carrier is erased in proportion to the magnitude of the signal, so that on replay the data is contained in the amplitude of the carrier. The accuracy is similar to direct recording but carrier erase has the advantage that DC signals can be recorded and the circuitry becomes very simple for low impedance sources such as thermocouples because no amplifiers or modulators are needed. This is important when the volume of an instrumentation package must be kept to a minimum.

The input to each channel on a recording head comprises two windings, one is connected to the transducer and the other is connected to a battery which provides a bias current of a few milli-amperes. Accuracy can be improved by using frequent calibration signals, but the quality of a record depends critically on stable tape characteristics and the method has only limited applications. A typical accuracy for a system recording thermocouple outputs is  $\pm 10\%$  of full scale,

Note (i)

A multiplex switch (Fig.5) was developed by Vactric Ltd to Space Dept Specification No. SP.245 for use with tape recorders. Six single-pole 24-way switches are driven at speeds of 3 to 12 rev/sec by a 6.3 volt DC motor and gear-box. Each switch comprises a printed circuit track which is plated with rhodium (thickness 0.01 inch approx) and the rubbing contact is made from hard gold. The noise level at the contact is less than 100 micro-volt peak to peak for running times in excess of 100 hours.

Note (ii)

A carrier frequency of 750 c/s is used to obtain recordings with the sub-miniature tape recorder when operating at a tape speed of  $1\frac{7}{8}$  inches/sec.

although  $\pm 5\%$  may be achieved in favourable conditions. A pre-amplifier is necessary for most transducers with relatively high output impedances, in which case FM recording is preferred.

Each of the recording methods described above have been used in Black Knight re-entry heads and on one occasion (head H2/05 on B.K.16) all three systems were used simultaneously on one recorder.

(b) Tape recorders

(i) Miniature recorder (Type IT-7-3-61)

The miniature recorder shown in Fig.6 has a tape capacity of 100 ft (width  $\frac{1}{2}$  inch) and is fitted with a 3 phase 65 volt 400 c/s motor which gives a recording speed of  $3\frac{3}{4}$  or  $7\frac{1}{2}$  inches per second. Two recording heads are fitted; one has four tracks and the other eight. FM and timing channels are usually connected to one head and the other is used for direct recording. When subjected to an acceleration of 100g in any direction and a vibration of 20g (peak) in the frequency range 10 to 3000 c/s, variation of tape speed and flutter level is less than  $\pm 1\%$ . A DC motor has been used to drive the recorder and even the flywheel has been omitted when weight saving and power supply economy have been of paramount importance. Armouring was extended, after initial flight trials, to cover the whole top plate i.e. both spools, the tape transport system and recording heads (see Fig.6).

(ii) Sub-miniature recorder (Type IT-7-7-61)

The sub-miniature tape recorder which was designed for the smaller re-entry heads carried by two-stage vehicles is shown in Fig.7. It has a tape capacity of 30 ft and only the take-up spool is armoured. Recording speeds of  $7\frac{1}{2}$ ,  $3\frac{3}{4}$  and  $1\frac{7}{8}$  inches per second are obtained by fitting different gear-heads to the DC motor. Double windings are provided on each track of twin recording heads so that all three methods of recording can be used. Because some of the re-entry heads fired as part of the "Dazzle" programme disintegrate before impact, additional tape protection is provided by enclosing the complete recorder in a durestos capsule fitted with a steel lining.

(iii) Long play recorder (Type IT-7-10-61)

The performance of the sub-miniature recorder is inferior to the miniature in terms of tape capacity, speed variation and flutter level. The long play recorder (Fig.8) was designed to improve these characteristics without increasing

the size significantly. The recording time is 20 minutes and an AC constant speed motor is fitted, as in the miniature recorder, but in this case the power unit is contained within the instrument. The recorder has yet to be used in flight but it has performed satisfactorily during ground tests.

Unlike the earlier recorders described above, the long play recorder could be started before launch because the complete flight time of Black Knight rockets does not exceed about 13 minutes. This would result in the following advantages:-

(I) Re-entry data could be obtained with increased reliability because it would not be necessary to start the recorder during flight.

(II) Time correlation between data obtained from the tape and events recorded by range instruments during re-entry could be improved because timing pulses recorded on the tape before launch could also be recorded against range time.

(c) Typical tape recorder installations

A schematic diagram illustrating the use of various units associated with the tape recorder systems is given in Fig.9. It comprises a typical re-entry head installation using five multiplexed FM channels, two direct record and one carrier erase channel. Four sections of the six-pole sampling switch multiplex the inputs to four FM channels (2, 5, 6 and 7). These channels are shared between 3 rate-gyroscopes, 3 accelerometers, 2 differential pressure transducers, calibration voltages and battery voltage monitors. The remaining two sections of the switch are used to sample 12 thermocouple outputs and 3 calibration voltages which are amplified as described in section 3.3(b) to frequency modulate channel 8. The carrier-erase method is used on channel 1 to record the output from an erosion gauge of the open-circuit type (see section 3.5). The staircase voltage output which makes the pick-off self-calibrating plus the low output impedance of the gauge is ideal for the carrier erase method of recording. Pulses from time marker SP4 Mk.2 are recorded on channel 4 by the direct record method (a pulse repetition frequency of 2.5, 5 or 10 Kc/s is selected according to tape speed).

Various sub-assemblies which form part of the tape recorder systems are shown in Fig.5 (Table 1 gives type and specification numbers) and several transducers and associated units are illustrated in Fig.10. Re-entry head H.06 (B.K.06) was the first to be fitted with an instrumentation assembly in which data handling was provided by a tape recorder system (Fig.11). A miniature tape recorder was used in the instrumentation assembly fitted in

re-entry head H2/09 (Fig.12) and a sub-miniature recorder was installed in the head carried by B.K.12 (Fig.13).

(d) Monitoring on the launcher

A signal could be received from heads fitted with telemetry before launch (see section 2.1) but this method could not be used to check the instrumentation in re-entry heads fitted with tape recorders. The policy adopted was to switch on all instrumentation except the recorder just before launch and check battery voltages and the inputs signals to the recording heads by using land-lines. The operation of the tape recorder which was started during flight was then checked for a few seconds. A stepping switch (Fig.5) inside the head was used to select monitoring points and economise in the number of land-lines. The same switch isolated the internal connections from the priming plug so that ionisation due to re-entry heating would not cause short-circuits within the head.

(e) Tape replay equipment

Recordings obtained from re-entry heads are replayed on a multi-channel equipment (Ref. No. EA Series T.I.R2) manufactured by Elliott Bros Ltd. This system enables all channels to be replayed and recorded on paper at the same time. Full details are given in Specification No. SP.230 (Magnetic Tape Replay Equipment) issued by Space Dept, R.A.E.

### 3 TRANSDUCERS

The design of most re-entry vehicles, especially those with a military application, is a compromise between conflicting requirements such as minimum structure weight but adequate strength. In addition, the body must be protected from the effect of kinetic heating during re-entry and it must be aerodynamically stable otherwise an undamped oscillation may destroy the vehicle or damage its payload. Not all the aerodynamic derivatives are easily determined in wind tunnels at hypersonic velocities (especially  $C_{Mq}$  and  $C_{M\dot{\alpha}}$ ) and neither is it possible to adequately simulate kinetic heating. Flight tests are therefore essential and a comprehensive range of transducers is required to monitor dynamic behaviour so that the aerodynamic characteristics can be determined. Skin temperature and erosion measurements are also required to investigate the performance of materials and measurements of vibration and deceleration provide additional information on the environment which a payload must withstand to survive re-entry.

There are two possible methods of making aerodynamic measurements in free flight<sup>4</sup>. The first is similar to wind tunnel techniques in which forces, moments and incidence  $\alpha$  are measured directly so that force and moment coefficients  $C_A$ ,  $C_N$  and  $C_M$  may be calculated as functions of  $\alpha$ . Black Knight heads fitted to single-stage vehicles were instrumented largely in accordance with this philosophy i.e. accelerometers were used to determine forces, moments were derived from rate-gyro measurements and incidence was obtained from differential pressure transducers (angle of attack had to be oscillating and the weight and moments of inertia had to be known). The alternative approach is to determine the aerodynamic derivatives  $C_{N\alpha}$ ,  $C_{M\alpha}$  and  $C_{Mq}$ . This method has limitations because the coefficient vs angle of incidence curve cannot be completely determined but since this technique requires much less instrumentation it is preferred where the space available is limited. This method, using only accelerometers, is employed in the smaller re-entry heads which are fitted with tape recorders and carried by two-stage vehicles.

The principal dynamic parameters for a typical re-entry head of a two-stage vehicle are shown in Fig.14. Transducers are selected to cover these ranges although the number of accelerometers is sometimes increased so that two ranges can be covered; one for the initial re-entry phase and another for later.

### 3.1 Pressure and acceleration transducers

These transducers are either the standard G.W. type (variable inductance) or the S.E.L. bridge type, according to the data link employed. The standard G.W. types (G.W.2A, T.D.237A, T.D.217A) used with telemetry have been fitted in three separating heads carried by single-stage vehicles, and the S.E.L. transducers illustrated in Fig.10 are used with the tape recorder systems. The S.E.L. transducers comprise a centre tapped variable inductance which forms two arms of a bridge network; energised at 3 Kc/s. Pressure or acceleration causes an out of balance current which is amplified and rectified to give a voltage output proportional to the magnitude of the quantity being measured. Oil damping is used in the accelerometers (Type S.E.55) to give a frequency response which is 3 db down at 20 c/s and capillary tubing gives the same affect in the pressure transducers (Type S.E.50 and S.E.70). The diaphragm type of sensing element used in these transducers gives a very low sensitivity to transverse acceleration which makes them particularly suitable for re-entry measurements where lateral accelerations can be very high. The 3 Kc/s bridge supply is provided by an oscillator (Type IT-1-3-54) which can energise up to

12 transducers. An amplifier is included in each transducer demodulator so that the full scale output from the pick-off can be adjusted to  $\pm 2.25$  volt or 0 to +4.5 volt.

### 3.2 Vibration measurement

The barium titanate vibration pick-off (Type F, Fig.10) manufactured by G.E.C., was used to measure vibration in several re-entry heads fitted with tape recorders. Although excessive telemetry bandwidth is required to transmit one channel of vibration information, the direct record method used on one channel of a tape recorder provides this data without loss of information from other transducers. Because a vibration pick-off is a high impedance device it is necessary to use a pre-amplifier (Type IT-3-12-51) to supply current into the low input impedance of the direct record amplifier (Type IT-2-2-57). The arrangement is shown diagrammatically in Fig.9. (Channel 3)

### 3.3 Temperature measurement

The effect of kinetic heating is one of the principal factors which influence the design of re-entry vehicles. To determine the type of flow around an experimental head, the position of transition from laminar to turbulent flow and the heat transfer factor it is necessary to measure the heat flow into the head during re-entry. This information can be obtained from skin temperature at several positions on the inside surface of the re-entry head, and it is concluded in Ref.5 that the most suitable transducer for this application is the thermocouple. Several types of thermocouple were therefore used to measure skin temperature in re-entry heads carried by single-stage and two-stage vehicles.

#### (a) Heads fitted with telemetry

Two methods have been described in which the R.A.E. sub-miniature telemetry sender is used to transmit the voltage outputs from several thermocouples in addition to the voltage and inductive outputs from other transducers<sup>5</sup>. In method (1) the voltage output from each thermocouple is amplified by a separate D.C. amplifier and transmitted on one channel of the telemetry system. Method (2) uses a single pre-amplifier for all thermocouples but the transmitter must be fitted with a special multi-track telemetry switch. In order to use a standard telemetry unit method (1) was adopted and a D.C. amplifier was designed for use with thermocouples.

The amplifier (Fig.16) is described in Ref.6 and so only the principal features are given in this section. Drift at the output was overcome by using

a chopper amplifier in which the thermocouple voltage was converted to a square-wave, amplified by an R.C. coupled amplifier and then demodulated in a synchronous rectifier (see Fig.15). Another reason for converting the thermocouple output to A.C. was to provide D.C. isolation between the input and output terminals of the amplifier by using transformer coupling. This was necessary because the telemetry sender earths the output circuit of the amplifier which is also earthed at the hot junction of the thermocouple connected to the input terminals. The effect of the telemetry earth on the output from a two-wire thermocouple is shown in Fig.17(a) and the corrected output using D.C. isolation is shown in Fig.17(b) (Two-wire thermocouples were used to ensure that the thermo-electric properties were known accurately i.e. within  $\pm 1\%$  of maximum output).

Because maximum temperatures of approximately  $1000^{\circ}\text{C}$  to  $1250^{\circ}\text{C}$  are measured nickel-chromium/nickel-aluminium (Chromel/Alumel) thermocouples have been used. This thermocouple gives a practically linear E.M.F./temperature characteristic above  $100^{\circ}\text{C}$ <sup>7</sup> which simplifies calibration and data analysis. The voltage gain of the pre-amplifier is set at 60 so that a 50 mv output from the thermocouple at  $1250^{\circ}\text{C}$  gives full scale deflection of the telemetry system. (i.e. +3 volts at the modulator.) The overall time constant of the amplifier is 5 m sec (approx) which causes an error of about 0.06% in the maximum temperature recorded during the re-entry of heads fitted to single-stage vehicles.

Each amplifier has a power consumption of 150 mW and is supplied from a 24 volt battery of sealed re-chargeable cells (capacity 50 milli-ampere hour). Re-entry heads H.03, H.05 and H.11 were instrumented in this manner and five calibration voltages of 0 to 50 mv were connected periodically to the input terminals of each amplifier to provide an overall calibration of each telemetry channel.

Resistance thermometer instrumentation<sup>2</sup> was also fitted in the majority of heads equipped with telemetry to measure air temperature, thermocouple cold-junction temperature and internal structure temperatures. Skin temperatures of second-stage assemblies (Fig.1(b)) have also been sampled before separation by using resistance thermometers connected to a temperature measuring system fitted in the main body of the vehicle<sup>2</sup>.

(b) Heads fitted with tape recorders

Two sampling switches and a single R.C. coupled amplifier are used as a variant of method (2) given in Ref.5. Simplification was possible because there is no earth connection at the output terminals of the pre-amplifier when

thermocouple voltages are recorded on tape instead of using telemetry. Due to the higher re-entry velocity of heads carried by two-stage vehicles and fitted with tape recorders, skin temperatures of up to  $1800^{\circ}\text{C}$  are possible at certain positions and so platinum/platinum-rhodium thermocouples<sup>7</sup> are fitted in addition to other types. Each output must be amplified to give a full scale reading of about +4.5 volt for FM recording (see section 2.2).

A schematic diagram of a typical thermocouple installation is shown in Fig.18. Two 24-way sampling switches are fitted to the same shaft with their moving contacts aligned, and the leads from each thermocouple are connected to similar segments on each switch. (Positive to switch No.1 and negative to switch No.2.) The moving contacts are connected to the input terminals of an R.C. coupled amplifier so that as the switches rotate the thermocouple voltage outputs are scanned and amplified to modulate the tape recorder system.

Because the input to the amplifier does not alternate (the polarity does not reverse) the charge on condenser  $C_3$  changes from the quiescent value and the voltage output of the amplifier tends to drift away from zero. This effect is reduced by short-circuiting the input and output terminals of the amplifier once per switch revolution i.e. with zero amplifier input the charge on condenser  $C_3$  is allowed to return to the quiescent condition.

In a typical installation, thermocouples are connected to segments 1 to 20, calibration voltages of 20 mv, 10 mv and zero are connected to segments 21, 22, and 23, and segment 24 is used to short circuit the input and output terminals of the amplifier to provide D.C. restoration of the complete waveform composed of 23 pulse amplitudes. The maximum drift per switch cycle occurs when the sampling switch operates at its lowest speed because the time interval between successive D.C. restorations is then a maximum. This occurs at a switch speed of 3 rev/sec (tape speed  $1\frac{7}{8}$  in/sec, see section 2.2) and for a typical sequence of input signals on segments 1 to 23 the zero shift at the amplifier output is about +1% of the voltage required to fully modulate the channel (+4.5 volt).

The sampling switches shown in Fig.18 form part of the six-pole 24-way multiplex switch illustrated in Fig.5 and described in Note (i) (section 2.2). A circuit diagram of the amplifier (specification No. SP.27) which is adjusted to give a voltage gain of about 225 is given in Fig.19.

The terminal board shown in Fig.18 forms the cold junction of the thermocouple installation which is thermally insulated in araldite so that it remains at the launch temperature throughout flight.

### 3.4 Rate-gyroscope installation

Rate-gyroscopes are fitted in Black Knight heads to measure angular rates about the pitch, yaw and roll axes during re-entry. The instrument used in the majority of installations has been the Miniature Rate Gyroscope Series 4, manufactured by Smiths Aircraft Instruments Ltd. The gyro requires a 3 phase 115 volt 400 c/s power supply of about 5 watts and the pick-off is energised at 26 volt 400 c/s. The restraining torque in this gyroscope is provided by a torsion bar which is selected to give an instrument with the required range.

Installations of three rate-gyroscopes in re-entry heads are energised from a 20 watt inverter (manufactured by Mortley Sprague) which is fitted with a transistor frequency control (accuracy  $\pm 1\%$ ) and supplied from a 26 volt battery. A typical installation is shown in the block diagram given in Fig.20. The pick-offs are energised by a transformer which has three secondary windings and its primary connected to one phase of the gyro supply. The voltage output from each pick-off is rectified and smoothed in a phase sensitive rectifier which is also supplied with a signal from a phase reference transformer (see Fig.20).

Scaling factors are usually adjusted so that an output of  $\pm 1.5$  volt is obtained from each phase sensitive rectifier for input rates of  $\pm 4.5$  rad/sec (pitch and yaw axes) and  $\pm 3.5$  rad/sec (roll axis). The linearity of the gyro pick-off system is within  $\pm 2\%$  of the desired straight line characteristic at all points, and the undamped natural frequency of the gyro gimbal assemblies are approximately 76 c/s (pitch and yaw) and 66 c/s (roll). The transient response of the damped gimbal assemblies show that the damping factor is about 0.63 and the overall time constant for a gyroscope and phase sensitive rectifier does not exceed  $7.5 \text{ m sec}^8$ .

As the oscillation frequency of the head at re-entry does not exceed 5 c/s (approx) the maximum error at the output of a rate-gyroscope due to time delays is about  $\pm 2.8\%$  of the peak reading. For a full scale oscillation the overall accuracy of the system at 5 c/s is approximately  $\pm 3.8\%$ . This assumes that the non-linearity of the data handling system is  $\pm 1\%$ , reading errors are  $\pm 1\%$ , the rate-gyro linearity error is  $\pm 2\%$  and the power supply frequency error is  $\pm 1\%$ .

The output from each rate-gyroscope is biased so that the voltage remains within the limits 0 to +3 volts required at the input of a telemetry transmitter. A similar output is used with frequency modulators of tape recorder systems.

### 3.5 Erosion gauges

The following techniques were developed to measure the surface erosion of durestos nose cones during re-entry into the atmosphere.

- (a) A radio-active method.
- (b) Pneumatic method.
- (c) Open-circuit method.

All three techniques were designed to measure the wall thickness of the head but only the radio-active system provides a continuous reading; the other methods give an output in the form of a series of steps. Systems (a) and (b) could only be used in the larger re-entry heads fitted to single-stage vehicles because of the volume occupied by the equipments. The more compact "open-circuit" method is used in the smaller heads carried by two-stage rockets.

#### Radio-active method

It was expected that a durestos nose cone would erode about 0.25 inch at the stagnation point (wall thickness 0.9 inch) during re-entry and the radio-active erosion gauge was developed to give a continuous measurement of this process. In the original scheme a  $\gamma$ -ray source and detector were to be mounted on the inside surface of the nose cone and the detector was required to discriminate between the direct radiation which would remain constant and the back-scattered radiation from the outside surface which would vary with skin thickness<sup>9</sup>. After some experimental work with a 5 milli-curie source of cobalt 60 the following discouraging features were revealed.

(i) The intensity of the reflected radiation was low and difficult to detect.

(ii) The time constant of the system was much too long (about 30 seconds).

(iii) Variations of the  $\gamma$ -ray intensity with time gave a noisy output signal.

Because of the difficulties listed above the following modified system was adopted:

A cylindrical plug of durestos is impregnated with 5% by weight of cobalt 60 and irradiated to give a source strength of 5 milli-curies. The source is diffused uniformly throughout the plug by tumbling cobalt in the form of 5 micron powder with asbestos flock which is then impregnated in the normal way to form durestos. The plug is then fitted in the wall of the nose cone from the outside so that it erodes with the surface and an ionisation chamber inside the head (Fig.21) is used to monitor the intensity of the direct radiation which is proportional to the volume of the plug and hence the thickness of the durestos wall. The voltage developed across a high resistance by the ionisation current is connected to an electrometer triode which acts as an impedance changer. The output from the triode is amplified<sup>6</sup> to give +3 volt which decreases as the radio-active source erodes with the nose cone. The response time of the final arrangement given in the schematic diagram Fig.21 is approximately 1 second. The ionisation chamber and cylindrical container which carries the electrometer valve in an anti-vibration mounting is shown in Fig.22.

Radio-active plugs and detectors to drawing G.W.36964 were used with telemetry in re-entry head H.05 and with a miniature tape recorder (F.M. channel) in head H.06. In both cases one erosion gauge was fitted at the nose (plug depth 0.75 inch) and another in the cone wall (plug depth 0.375 inch).

#### Pneumatic method

Three blind capillary holes are drilled to different depths in a durestos plug which is fitted in the wall of the nose cone from within the head (see Fig.23). The capillaries are connected to a nitrogen bottle, via an orifice, by a single metal tube and the complete system is filled with nitrogen at a pressure of 1000 lb/in<sup>2</sup>. A transducer acts as a flow meter by measuring differential pressure across the orifice and during the erosion process the following events occur:-

(i) With every part of the system initially at 1000 lb/in<sup>2</sup> the transducer registers zero pressure drop across the orifice.

(ii) When surface erosion opens the longest capillary the transducer indicates a pressure drop across the orifice caused by a flow of nitrogen. The magnitude of the pressure difference depends on the relative impedance to flow offered by the orifice and the capillary hole.

(iii) As erosion progresses the opening of successive capillaries increases the flow rate with a corresponding increase in differential pressure.

After the first capillary opens the pressure in the nitrogen bottle and the differential pressure across the orifice gradually decrease, so that at the second increase in flow the transducer output has fallen below the pressure indicated when the first capillary opened. Instead of a series of steps which would be obtained from a constant pressure supply, the transducer gives a sawtooth output having a rising average level (see Fig.23). Increments of approximately equal amplitude are achieved with a constantly falling reservoir pressure by making successive capillaries of larger diameter. In this way a greater fraction of the remaining pressure is dropped across the orifice at each step to obtain equal pressure changes in the output from the transducer.

The length of the capillary holes in the plugs were arranged so that erosion depths of  $1/16$ ,  $1/8$ , and  $3/16$  inch could be detected by a 0 to 750 lb/in<sup>2</sup> pressure pick-off. Transducer type G.W.2A was used with telemetry in re-entry head H.05 and type S.E.50 was used with a miniature tape recorder (F.M. channel) in head H.06.

#### Open-circuit method

Electrical conductors are embedded at various depths below the surface of a nose cone which must be made from a non-conducting material for this method to be applicable e.g. durestos. Each conductor short-circuits a resistor and these are connected in series to form a chain which has an initial resistance of zero. As the surface erodes the short-circuits become open-circuits and the total resistance of the resistor chain increases in steps. In practice a cylindrical plug of nose cone material is divided into half cylinders and the short-circuiting loops are printed as a circuit on the flat surface of one section. The two sections are then glued together and machined to fit a cavity in the nose cone.

The illustration in Fig.24 shows the construction of the open-circuit erosion gauge and a typical bridge-circuit used to monitor the total resistance of the resistor chain. The triangular print at the top of the plug is used as a datum in the machining process to set the first conductor at the correct depth below the surface. Only five loops have been included in later gauges giving a maximum output from the bridge circuit of 20 mv in 4 mv steps which are either recorded on tape by the carrier erase method (see section 2.2) as in re-entry head H2/06 or amplified like a thermocouple output (see section 3.3(b)) for F.M. recording.

Typical durestos erosion gauges comprise five equi-spaced conductors arranged at depths below the surface of 0.02 to 0.22 inch for a plug at the stagnation point, or 0.02 to 0.10 inch for a plug fitted in the side of the cone.

#### 4 OTHER INSTRUMENTATION

##### 4.1 Second-stage ignition equipment

The design and development of equipment fitted in the second-stage adaptor-bay of two-stage vehicles (see Fig.1(b)) is given in Ref.10 and only a summary is included in this section. This installation controls the sequence of events from separation of the second-stage assembly to re-entry of the head.

The second-stage is spin stabilised on separation from the main body and maintains the correct attitude for re-entry throughout its trajectory. A Philips ionisation gauge and associated electronics (Fig.25) has been fitted to all second-stage assemblies so that a programme switch is started when the ram-pressure in the gauge reaches a value of  $5.3 \times 10^{-4}$  mm hg during descent. This fires the second-stage propulsion unit and separates the head (tape recorder running) from the burnt-out rocket motor at an altitude of 200 000 ft (approx) giving maximum re-entry velocity. This technique was developed for use with heads designed to investigate the effect of kinetic heating, erosion rates and re-entry dynamics.

A programme switch has been fitted to start the re-entry sequence in second-stage assemblies used in the "dazzle" project because of the higher altitude at which it must be initiated (approximately 1 million feet). The ram-pressure system has also been included however as a secondary method which will operate at a lower altitude to prevent a complete loss of information if the switch fails to initiate the re-entry sequence or if some malfunction of the first-stage propulsion system causes a reduced time interval to re-entry.

##### 4.2 Time delay unit

Owing to limited tape capacity the miniature and sub-miniature tape recorders must be started from 7 to 10 minutes after launch so that the data recording period occurs during re-entry into the atmosphere. A time delay switch was developed to meet this requirement and the complete unit comprises a voltage stabiliser, 50 c/s square-wave oscillator and single-phase synchronous motor which drives the switch through a slipping clutch to close two contacts after a selected time interval. The motor is fitted with two 12 volt windings which are supplied by the power unit as shown in Fig.26.

The synchronous motor is energised before launch and its operation is monitored whilst the clutch functions in the slipping mode and the switch remains in the start position. The time interval begins when a detent is withdrawn electrically to release the switch and this may occur at launch (single-stage vehicles e.g. B.K.06) or at separation of the second-stage assembly e.g. B.K.18<sup>10</sup>. The torque needed to drive the switch is less than the torque required when the clutch is operating in the slipping mode and so the possibility of failure after the pre-flight check is remote.

Time delays of up to 15 minutes (approx) can be set on the unit (Fig.27) and the total power consumption of the motor, oscillator and voltage stabiliser is about 2 watts.

#### 4.3 Time correlation unit

Although the unit described in this section has not been flight tested it did form part of the instrumentation development programme for Black Knight and it is included in this Report for completeness. The unit was developed from the basic timer<sup>11</sup> which is used in a modified form (time marker SP.4 Mk.2) to record timing pulses on magnetic tape in re-entry heads. These time markers cannot be correlated with range time however because all recorders used until the present have been started in flight. The block diagram given in Fig.28 shows a unit which was developed to provide time correlation between data from tape recorders started in flight and information obtained by range instruments. The output from the timer comprises three synchronised voltage waveforms as follows:-

- (a) The normal timing pulse (2.5 Kc/s or 5 Kc/s).
- (b) A timing pulse having an interval of 25.6 sec.
- (c) A square-wave having a period of 51.2 sec.

The unit is fitted in the head and timing pulses (a) and (b) are recorded on separate channels of the tape recorder. Square-wave (c) is transmitted on one channel of the telemetry sender in the body until the head or second-stage assembly separates shortly after "all-burnt". The square-wave is recorded against range time at the telemetry receivers (accuracy  $\pm 12$  m sec i.e. time for one revolution of the telemetry switch) until separation, so that pulse (b) on the tape can be correlated with range time throughout the remainder of the flight. An approximate re-entry time from range instruments (accuracy say  $\pm 5$  seconds) can be refined from the recovered tape record by comparing the output from a longitudinal accelerometer with the positions of timing pulse

(b) which are known in terms of range time (accuracy  $\pm 12$  m sec). Timing pulse (a) then gives a fine time scale which can be used to correlate "on-board" measurements with data obtained during re-entry by range instruments. An accuracy of  $\pm 12$  m sec gives a spatial resolution of  $\pm 138$  ft for heads fitted to single-stage vehicles and  $\pm 192$  ft for two-stage firings.

Although a 5 Kc/s timing pulse is shown in Fig.28 (pulse (a)), 2.5 Kc/s for use with a  $1\frac{7}{8}$  in/sec tape speed can be obtained by suitable frequency division. A voltage stabiliser is included in the unit so that it can be supplied from a 26 volt battery and the total current consumption is about 200 mA. A circuit diagram and assembly details are given in drawings Nos. G.W.44247 to G.W.44250.

#### 4.4 Flash unit and detector

Black Knight vehicles are fired at night so that optical methods can be used in addition to other tracking techniques during exit and re-entry into the atmosphere. A "marker-flash" system was therefore fitted in heads carried by single-stage vehicles so that the trajectory and velocity at re-entry could be determined from ballistic cameras and photo-multipliers on the range.

Pyrotechnic flash units (developed by A.R.D.E. Langhurst and Armament Dept R.A.E.) were used to provide the trajectory markers and their construction and operation were similar to the type A cartridge used in the main body of the vehicle<sup>2</sup>. From two to eight pyrotechnics were ejected during re-entry at intervals of 1 to 5 seconds depending on the number fitted. The first flash was ejected at about 140 000 ft when a 1 g switch, sensing deceleration, started a programme clock controlling the ejection sequence. Since this altitude is less than the maximum "all-burnt" altitude of the single-stage vehicle (385 000 ft approx) it was possible to use a smaller cartridge than type A with a reduced light output. The type B unit for re-entry heads is shown in Fig.29 (the smaller cartridge) and typical performance figures at sea level are; total light output  $1.57 \times 10^5$  candle-sec, peak intensity  $2.55 \times 10^7$  candles, time to peak intensity 1.9 m sec and total burning time 23.6 m sec.

To ensure that re-entry velocity could be obtained from ballistic camera data the time at which each flash occurred was also monitored by a detector<sup>2,12</sup> in the head and transmitted on one channel of a telemetry sender (head H.03 etc) or multiplexed, with other voltage outputs, onto an F.M. channel of a tape recorder (head H.06 etc). The photo-conductive cell which triggers the detector was fitted behind a transparent silica window in the base dome of the head and the sawtooth voltage output from the unit was adjusted to remain within the range 0 to +3 volts for both data handling systems.

The re-entry velocity and trajectory of heads fitted to two-stage vehicles are obtained by using shuttered ballistic cameras because the higher velocity ensures radiation in the visible spectrum which can be recorded by range instruments.

5     CONCLUSIONS

Instrumentation systems developed for Black Knight re-entry heads and second-stage assemblies have been described in this Report. Flight results are not given because these are included in papers on specific aspects of the re-entry experiments<sup>13,14</sup> and in Post-Firing Meeting reports. The reliability of the data handling equipment has been very satisfactory throughout the firing programme as there has been no loss of information due to telemetry defects and only one tape recorder failed to operate correctly.

Acknowledgements

The authors wish to acknowledge the assistance received in the design, production, testing, and application of the various instrumentation systems described in this Report. In particular the assistance received from the Black Knight instrumentation group and Instrumentation and Ranges Dept R.A.E., especially the tape recorder section, is gratefully acknowledged.

---

Table 1

Summary of recorders and sub-assemblies used in tape recorder  
data handling systems

Unit	Type number	Ministry of Aviation specification number
Miniature tape recorder	IT-7-3-61	
Sub-miniature tape recorder	IT-7-7-61	
Long play tape recorder	IT-7-10-61	
Tape recorder power unit	IT-4-1-52	IT.233
Record amplifier and bias oscillator	IT-2-2-51	IT.235
Pre-amplifier	IT-3-12-51	IT.228
Frequency modulator	IT-1-5-57	IT.265
F.M. power unit	IT-4-2-52	IT.234
3 Kc/s Oscillator for S.E.I. transducers	IT-1-3-54	IT.221
Transducer demodulator	IT-1-10-51	IT.221
Thermocouple amplifier	IT-3-15-51	SP.27 Mk.2
Multiplex switch (6 pole 24 way)		SP.245
Time marker SP.4 Mk.2		SP.246

REFERENCES

<u>No.</u>	<u>Author</u>	<u>Title, etc</u>
1	H.G.R. Robinson	The ballistic test vehicle Black Knight. R.A.E. Tech Note No. G.W.503. December 1958.
2	D.I. Dawton F.R. Knott A.P. Waterfall	Black Knight Instrumentation Systems Part 1. Main body instrumentation. R.A.E. Tech Report No. 66019. January 1966
3	-	Specification No. TD.238 for the telemetry sender (Type TD.238) and inductive sub- commutation unit. Instrumentation and Ranges Dept, R.A.E.
4	A.P. Waterfall	Techniques of measurement and automatic analysis of dynamic motion with applications to some re-entry experiments. R.A.E. Tech Report No. 65038. February 1965
5	D.I. Dawton F.R. Knott G.S. Barford	The technique of kinetic heating measurement in rocket test vehicles: with particular reference to experiments made in C.T.V.5 Series 2. R.A.E. Tech Note No. G.W.509. February 1959
6	F.R. Knott	A telemetry pre-amplifier for use with thermo- couples. R.A.E. Tech Note No. Space 63. April 1964
7	B.F. Billing	Thermocouples - a survey. R.A.E. Tech Memo No. Met.122. November 1953
8	W.R. Simons	Miniature rate gyros, Series 4. Smith's Aircraft Instruments Ltd. Report No. TR/ED2/SMI/17. July 1958
9	Putman, Jefferson Cameron, Kerry Pulsford	Tube wall thickness gauge with selection of back-scattered $\gamma$ radiations. Jour. Sci. Instr. Vol.32. October 1955
10	F.R. Knott	Ram-pressure as the basis of event initiation in Black Knight re-entry trials. R.A.E. Tech Note No. Space 65. May 1964

REFERENCES (Contd)

<u>No.</u>	<u>Author</u>	<u>Title, etc</u>
11	G.G. Haigh	Crystal controlled time marker for flight recording in rockets. R.A.E. Tech Note No. G.W.587. August 1961
12	F.R. Knott	Missile-borne transistor flash detector. R.A.E. Tech Note No. G.W.520. August 1959.
13	H.W.B. Gordon L.W. Parkin	A summary of Black Knight flight data from 1958 to 1962. R.A.E. Tech Note No. Space 57. February 1964.
14	H.W.B. Gordon	Proving trial of the Black Knight vehicle for re-entry physics experiments. R.A.E. Tech Note No. Space 49. October 1963

---

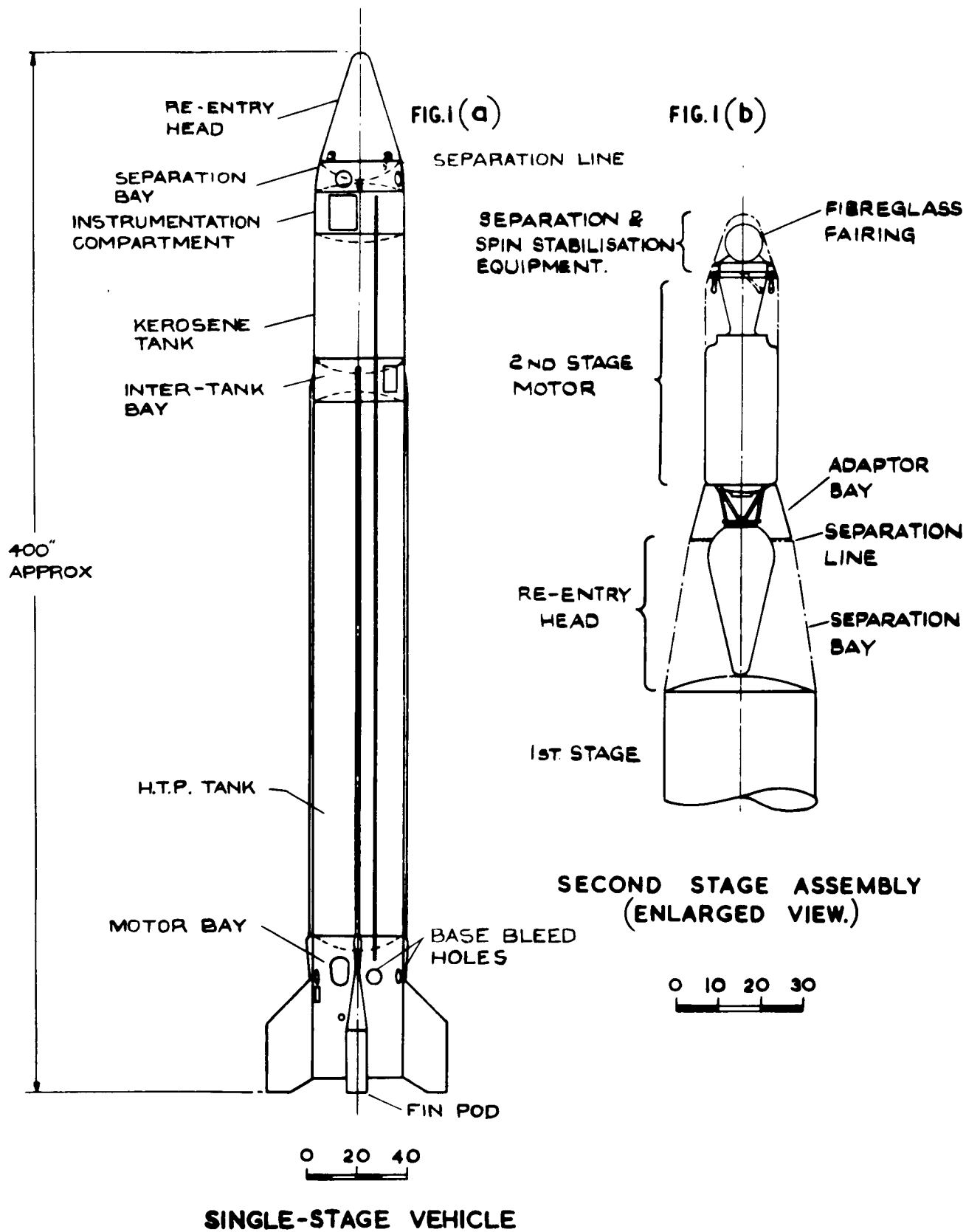

FIG. 1 BLACK KNIGHT CONFIGURATION

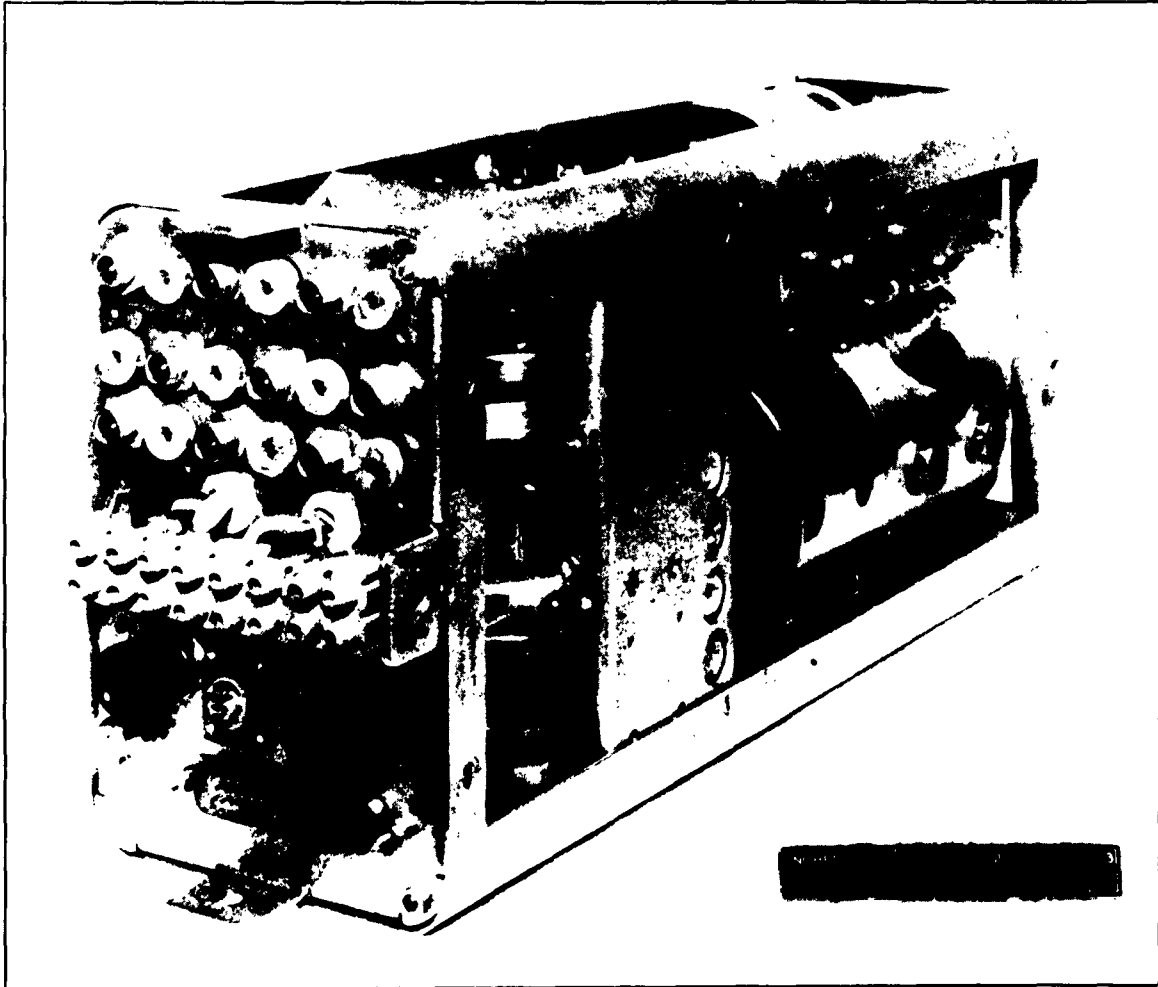
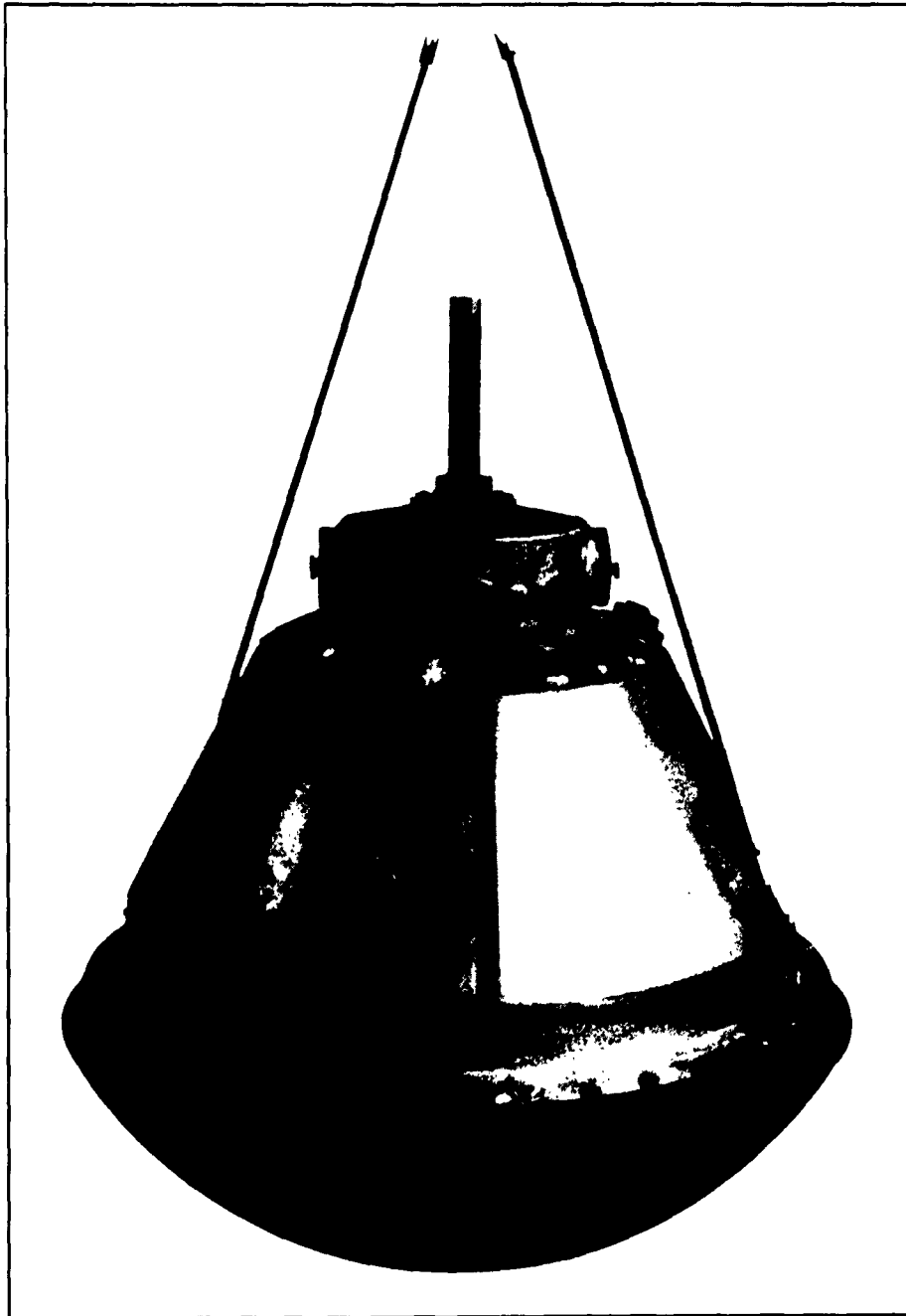

Fig.2 465Mc/s telemetry transmitter fitted in re-entry heads



**Fig.3 Complete head assembly showing telemetry aerial  
on base-dome of head H.11. (B.K.07)**

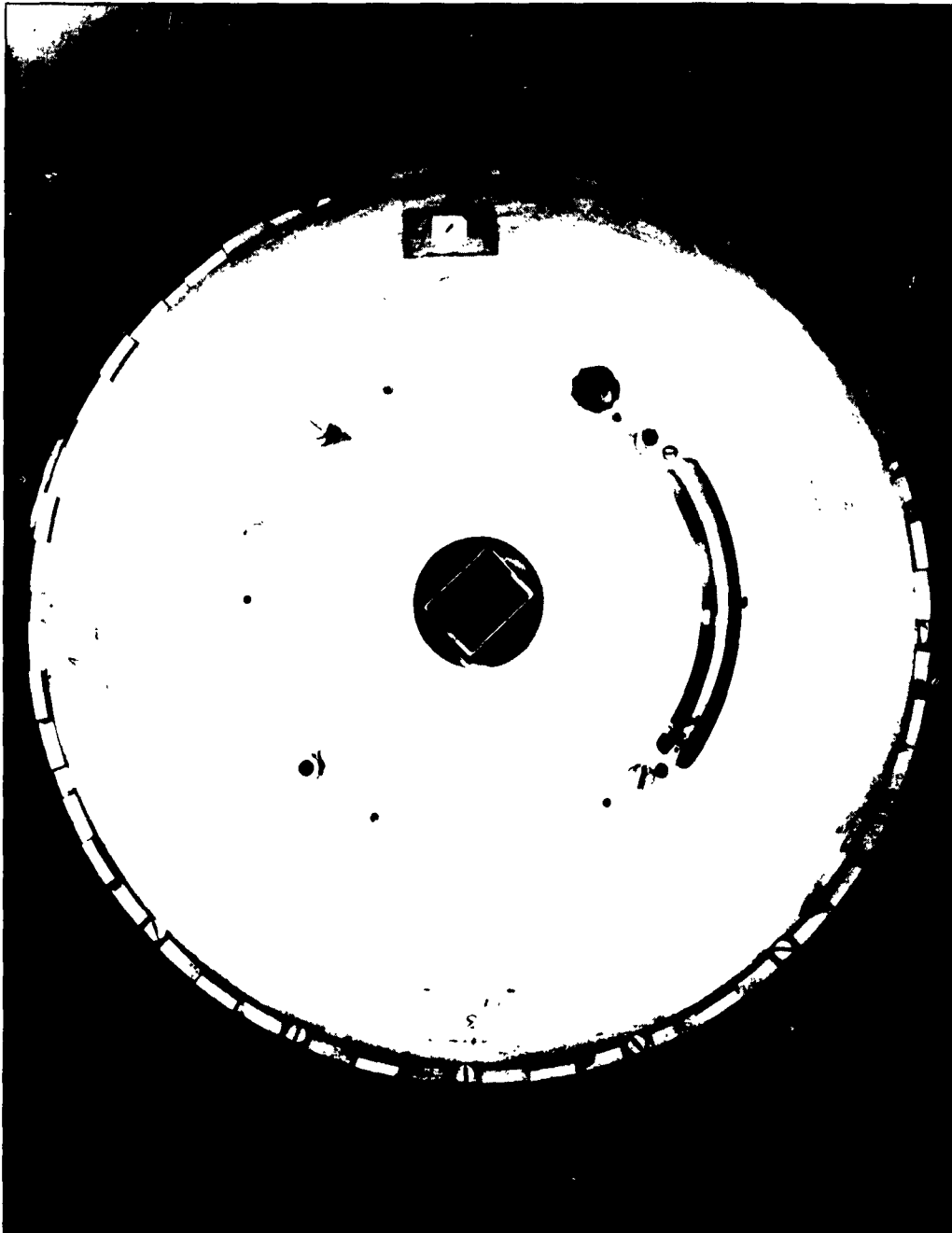

Fig.4 Base-dome assembly showing telemetry slot-aerial in head H2/03 (B.K.17)

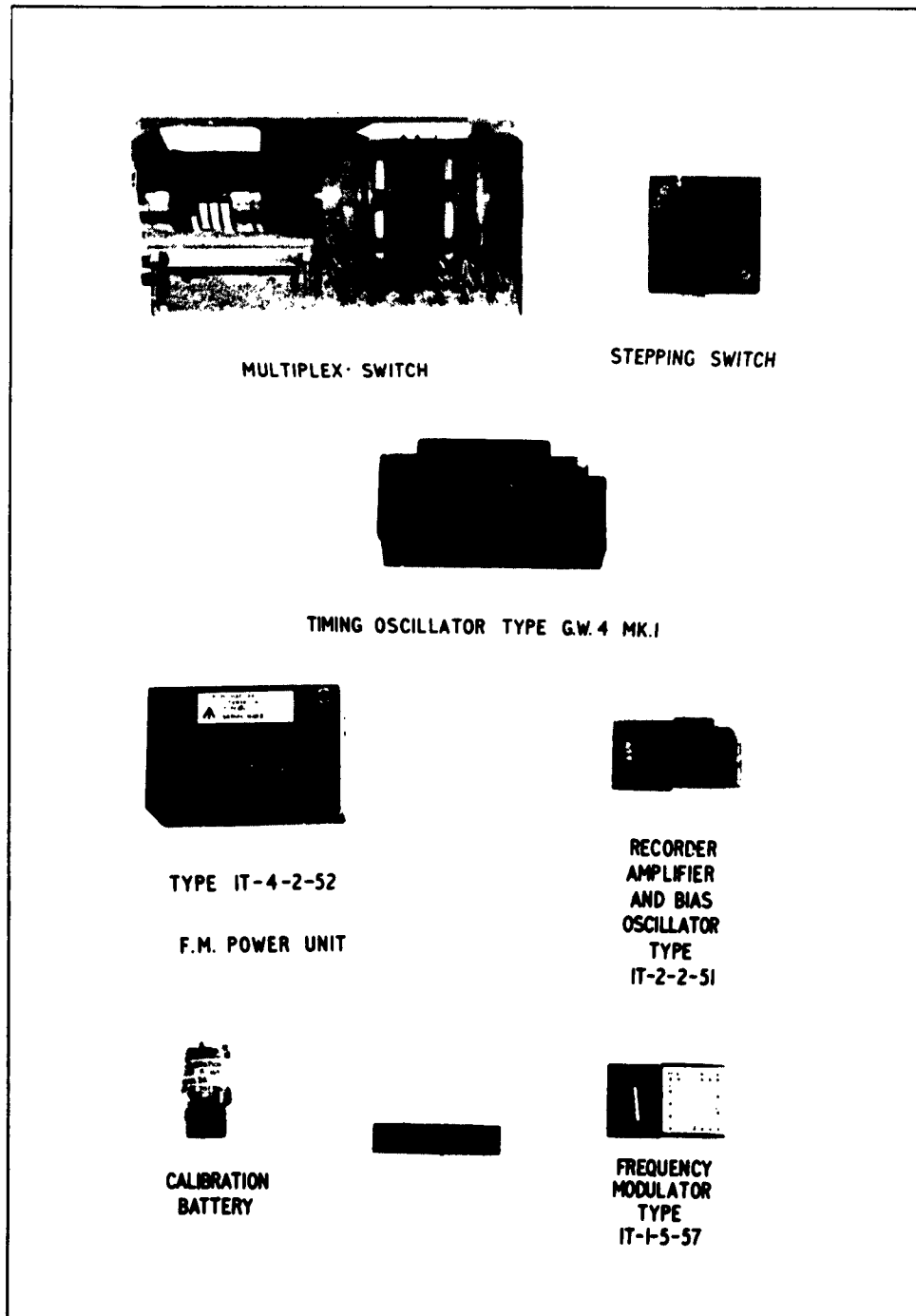

Fig.5 Sub-assemblies used in tape recorder systems

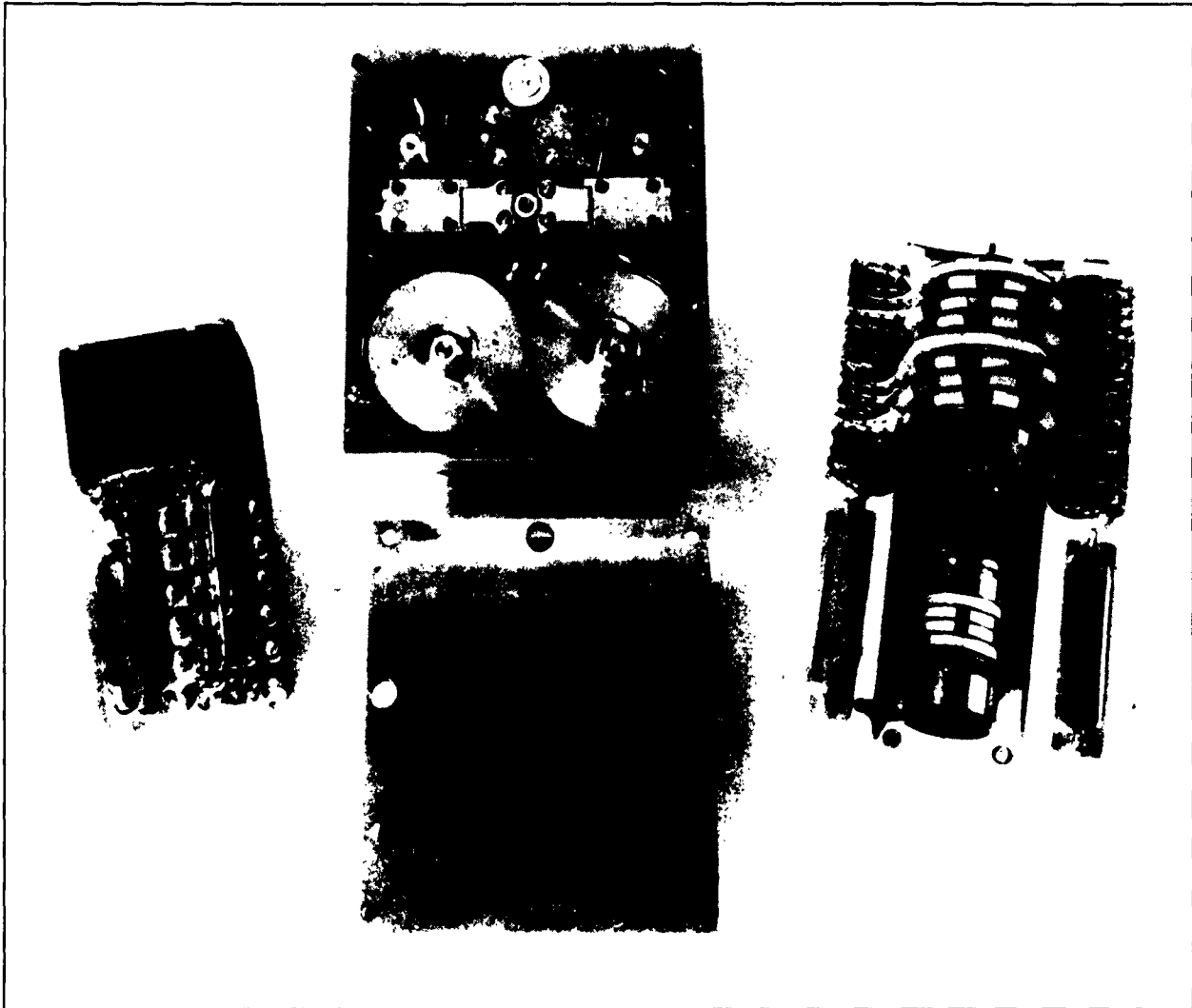

Fig.6 Miniature tape recorder, multiplex switch (8 tracks)  
and power supply switches

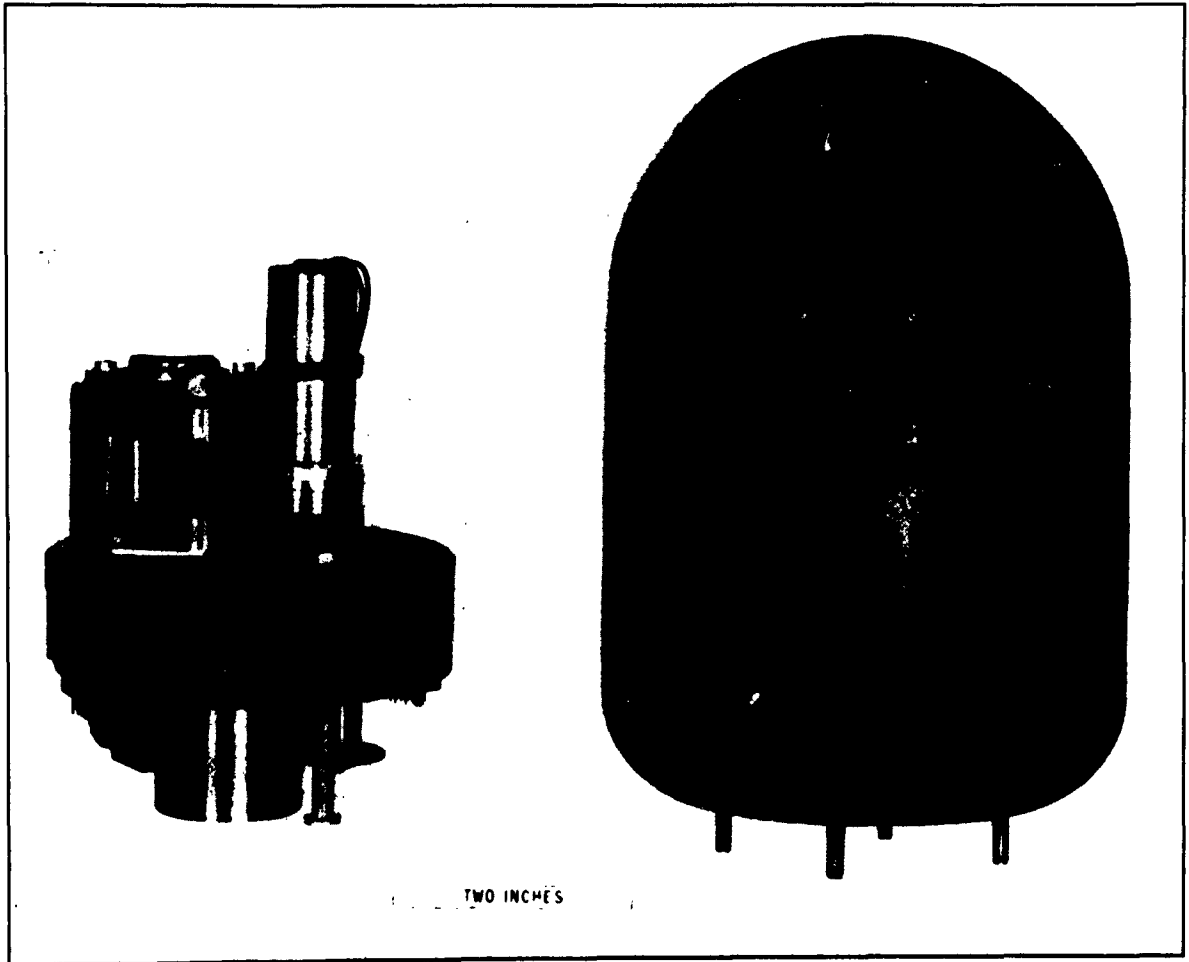

Fig.7 Sub-miniature tape recorder and durestos capsule

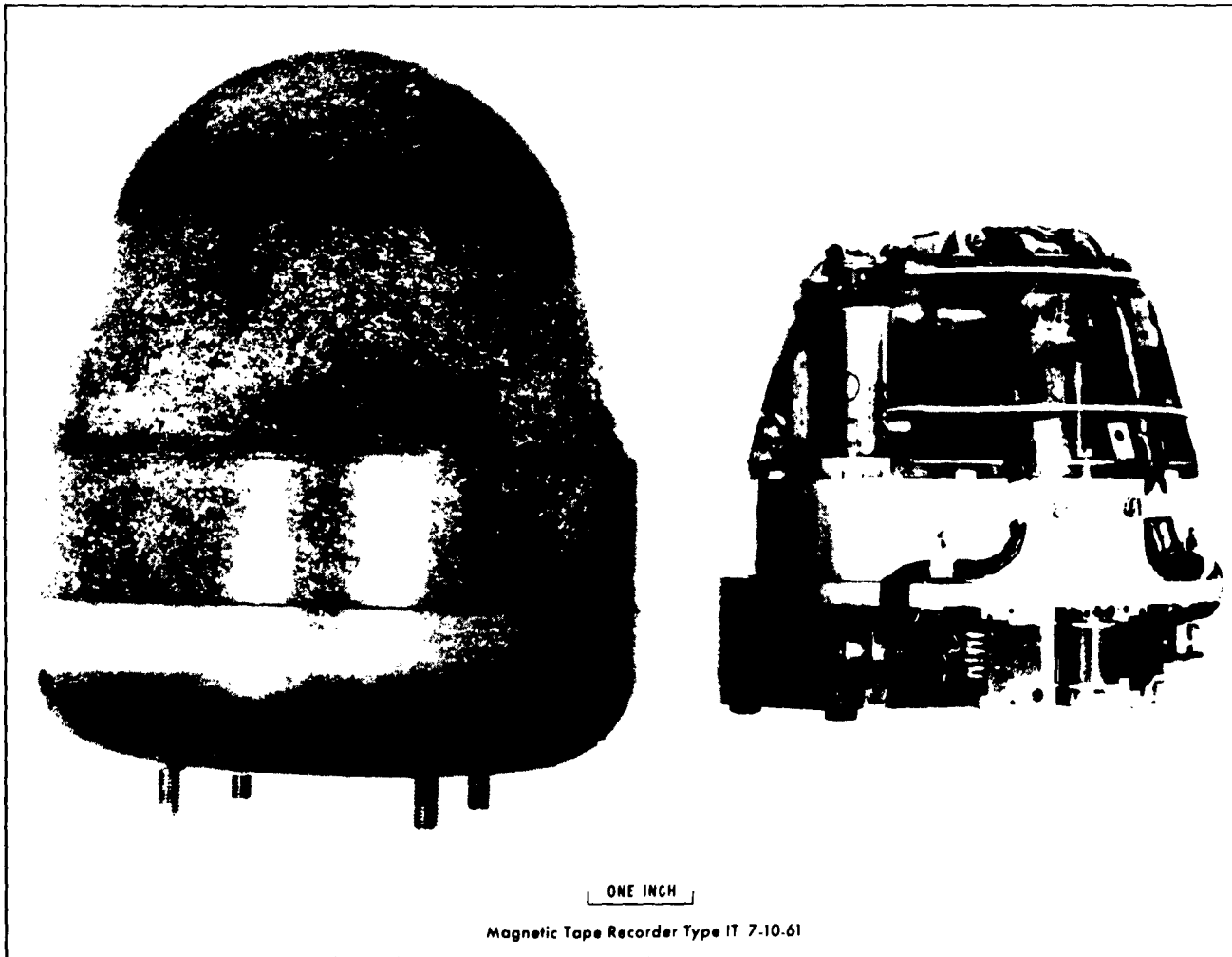

Fig.8 Long play tape recorder, and duresitos capsule

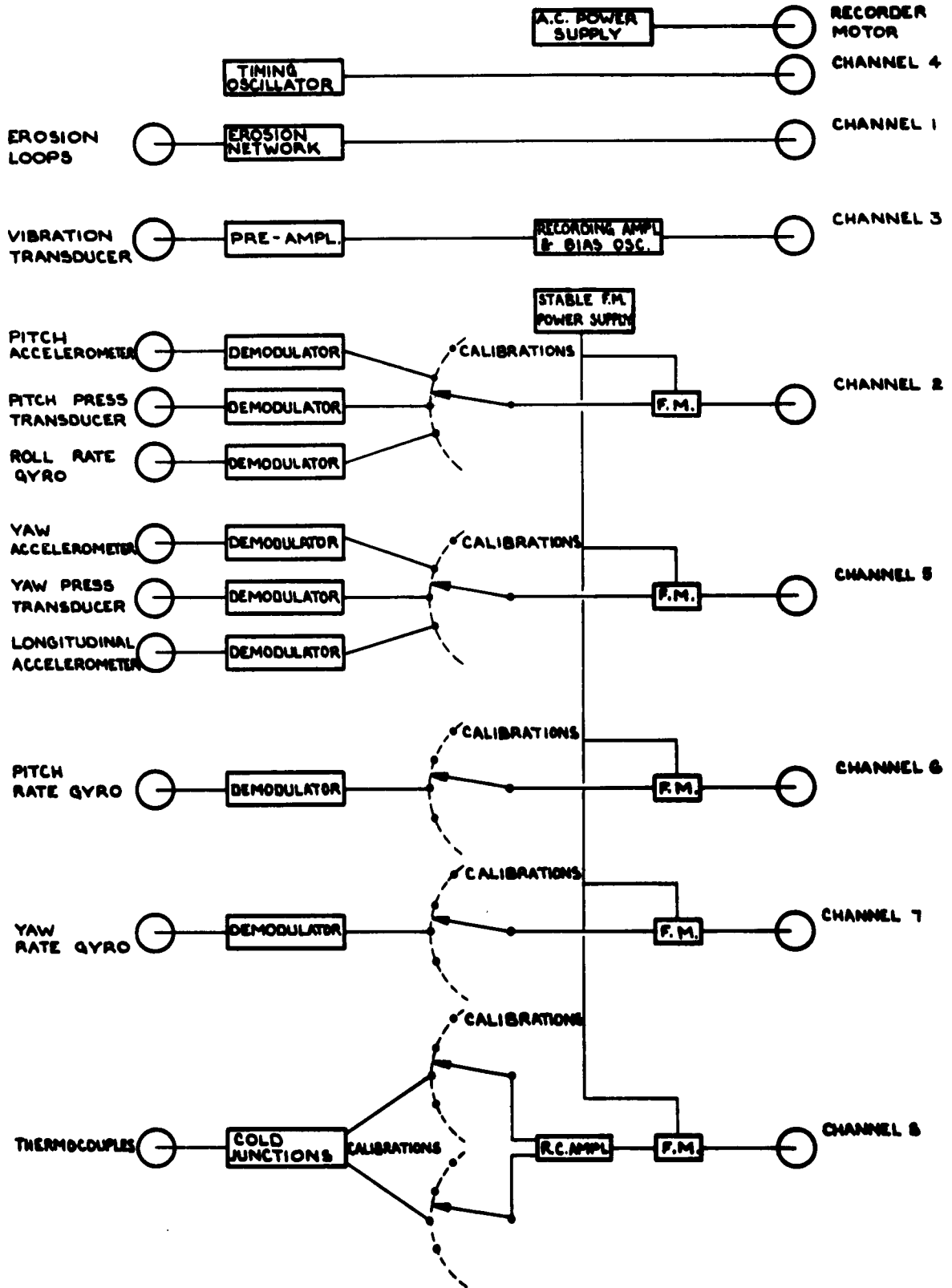

FIG. 9 TYPICAL TAPE RECORDER SYSTEM

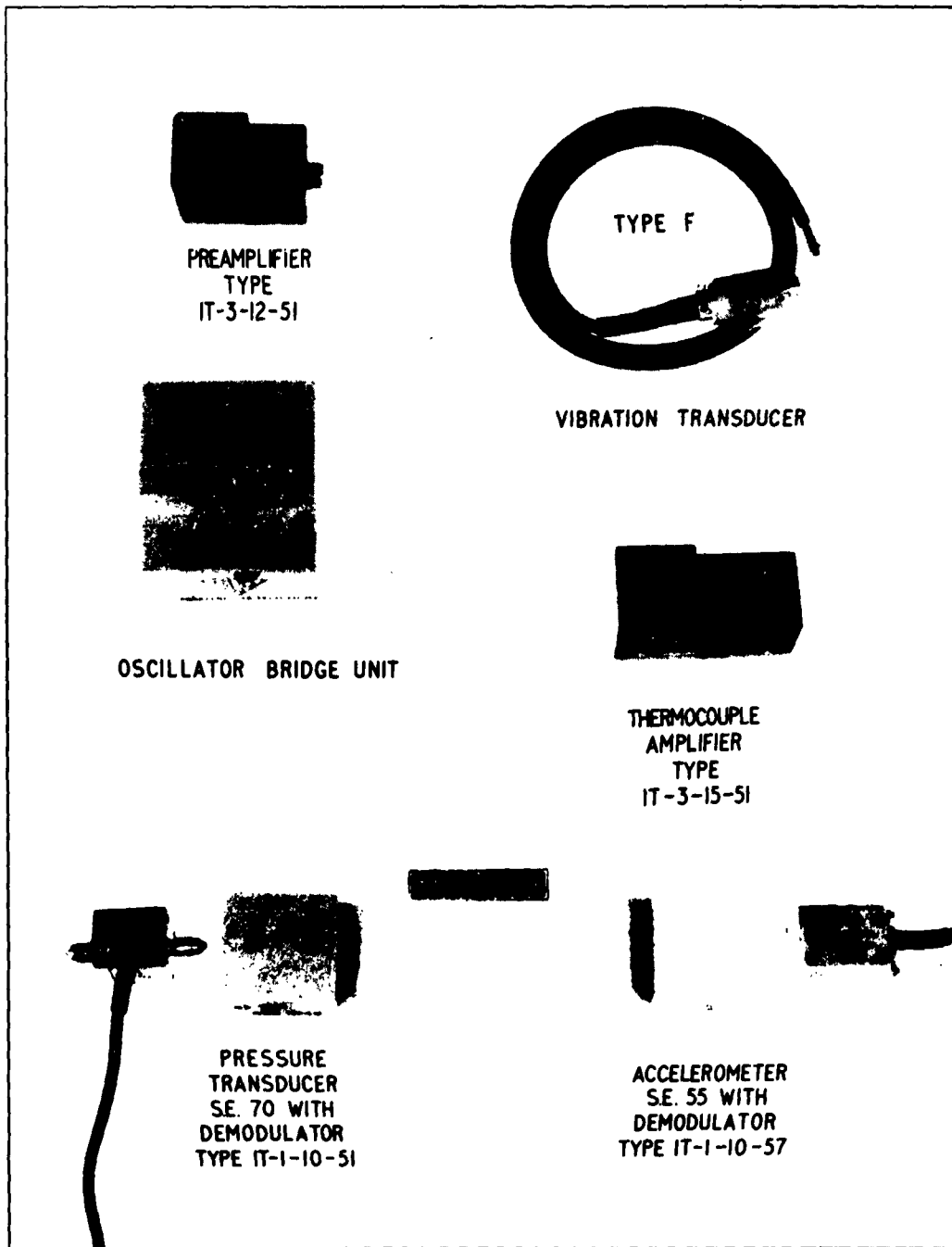

Fig.10 Transducers used with tape recorders

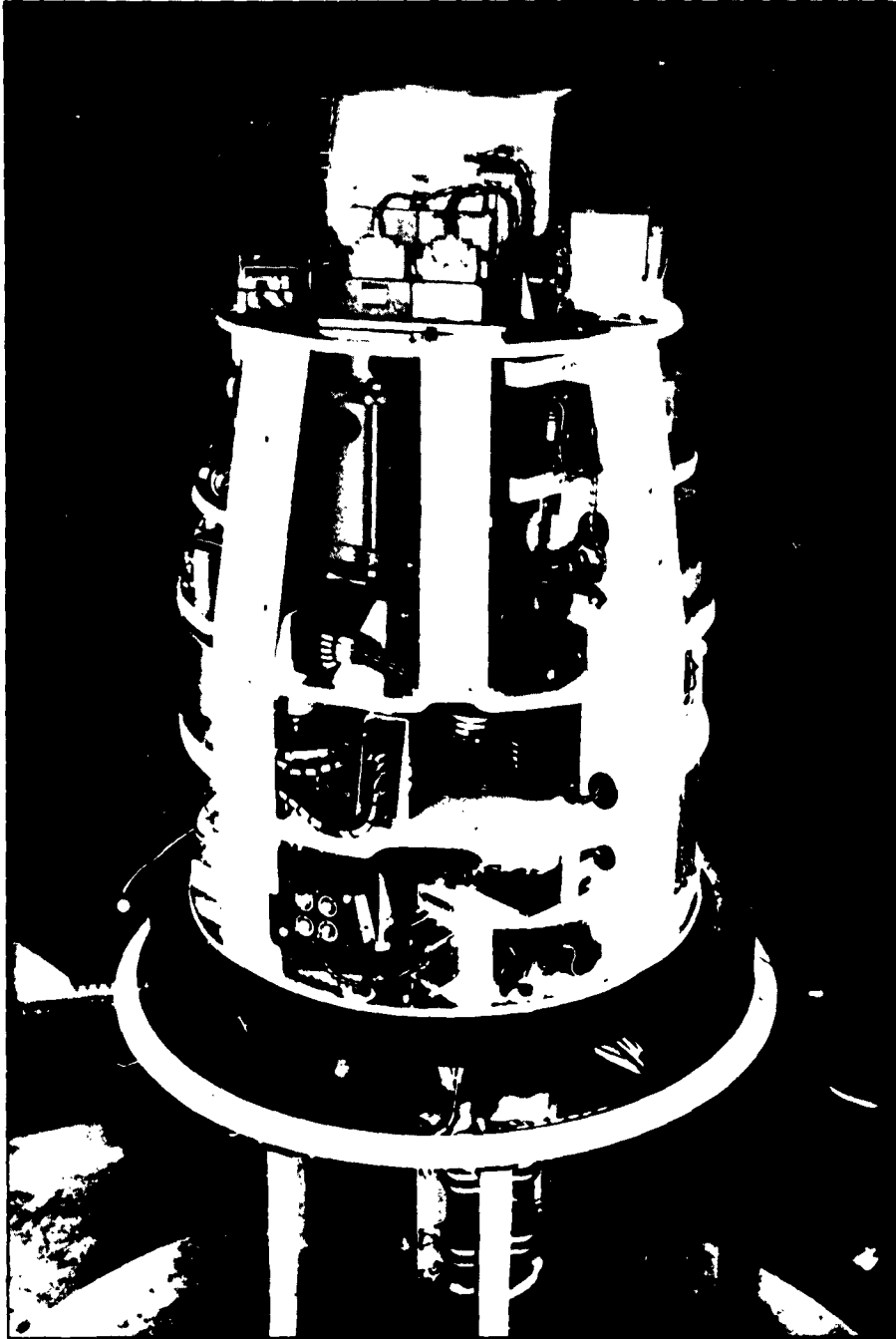

Fig.11 First instrumentation assembly to include a tape recorder.  
(Head H.O 6 fitted to B.K. 06)

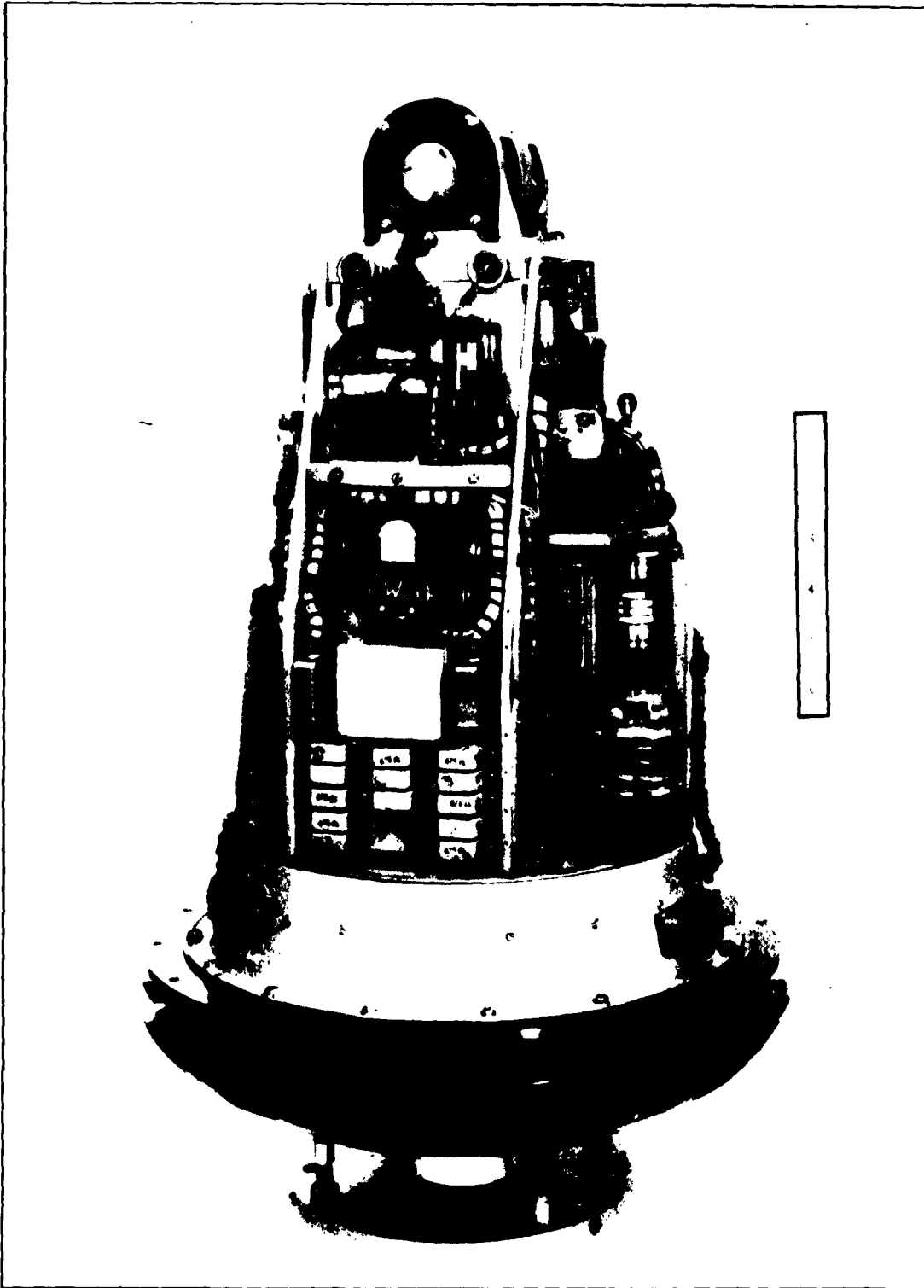

Fig.12 Tape recorder instrumentation in head H2/09 fitted to B.K.18

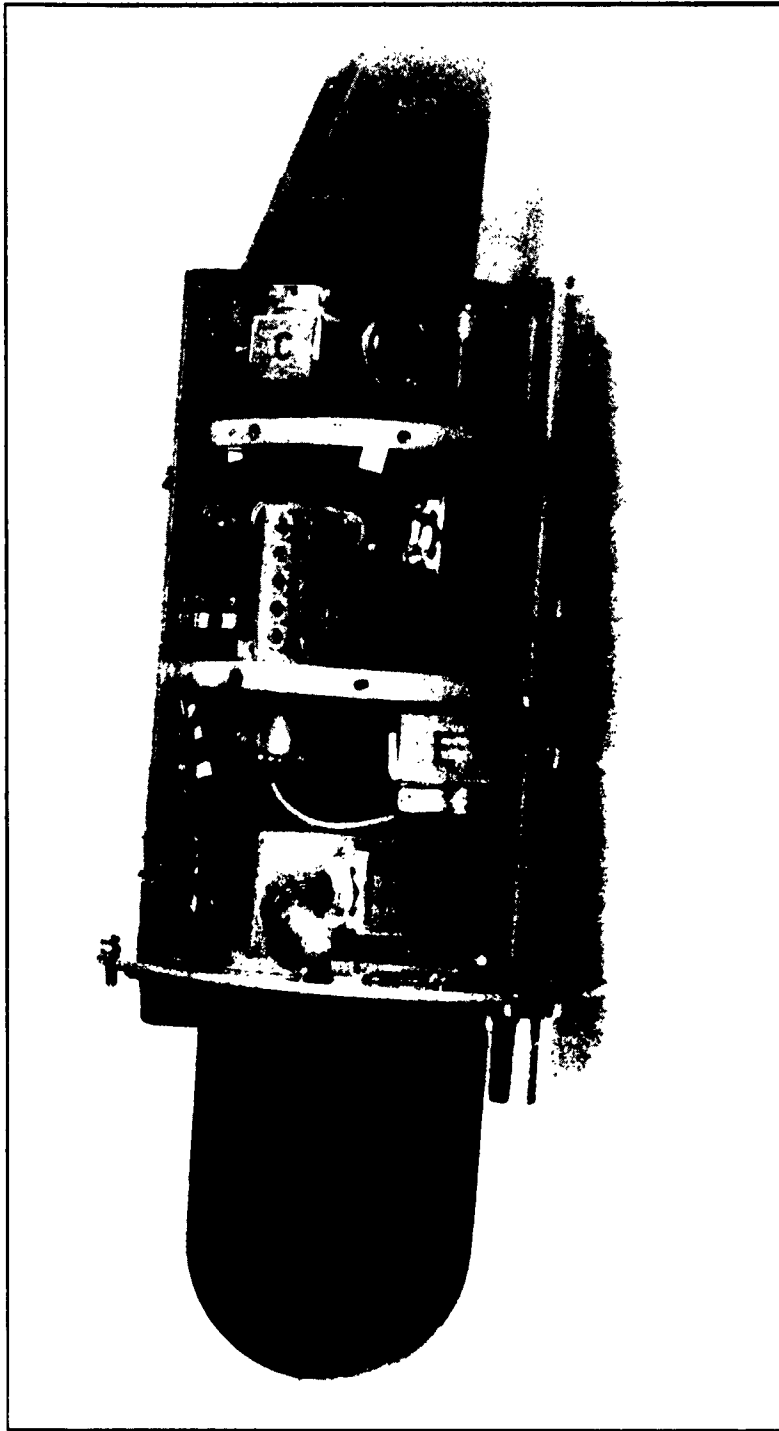

Fig.13 Tape recorder and instrumentation in re-entry head fitted to B.K.12

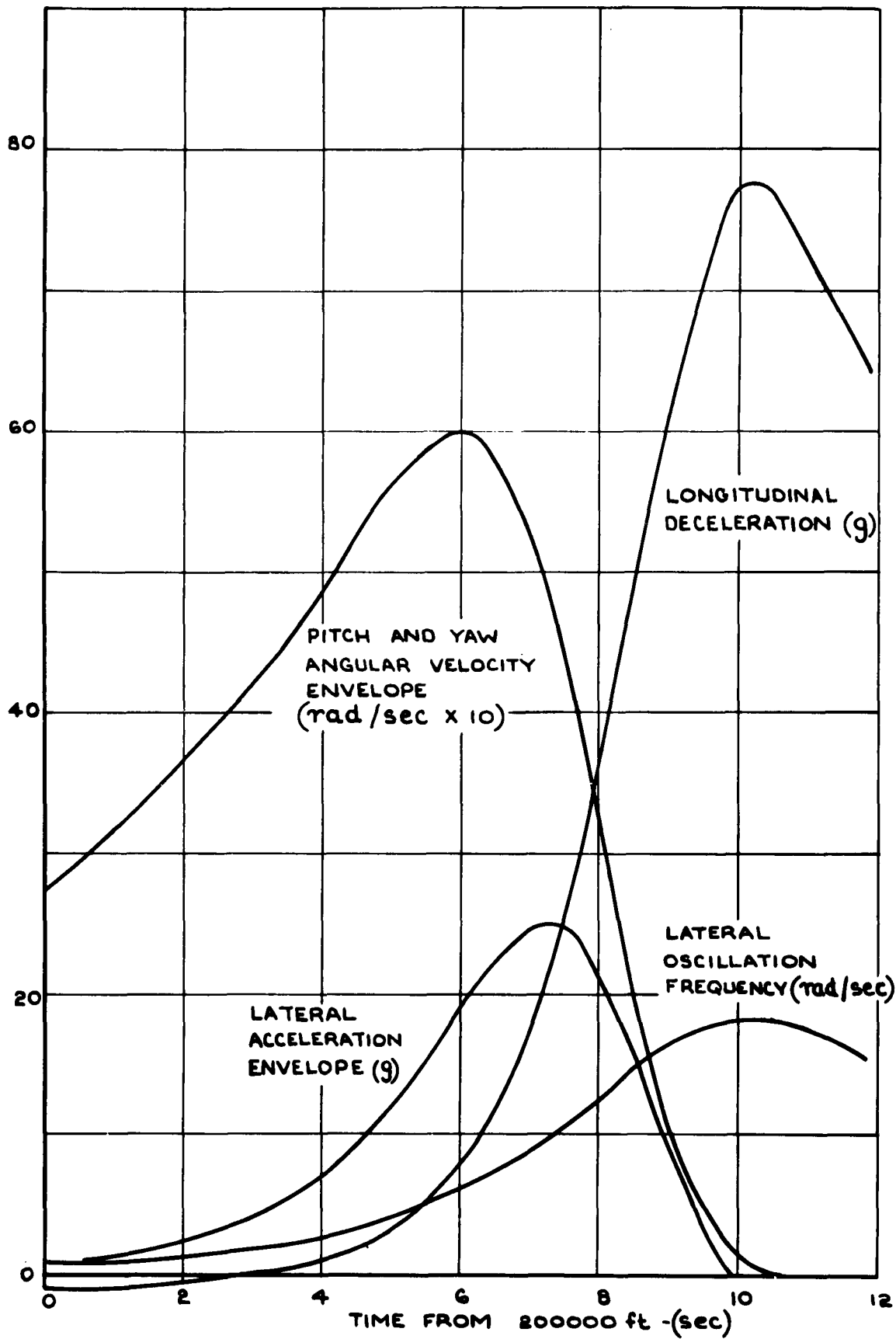

FIG. 14 VARIATION OF OSCILLATION FREQUENCY AND DYNAMIC PARAMETERS DURING A TYPICAL RE-ENTRY

004 - 900078

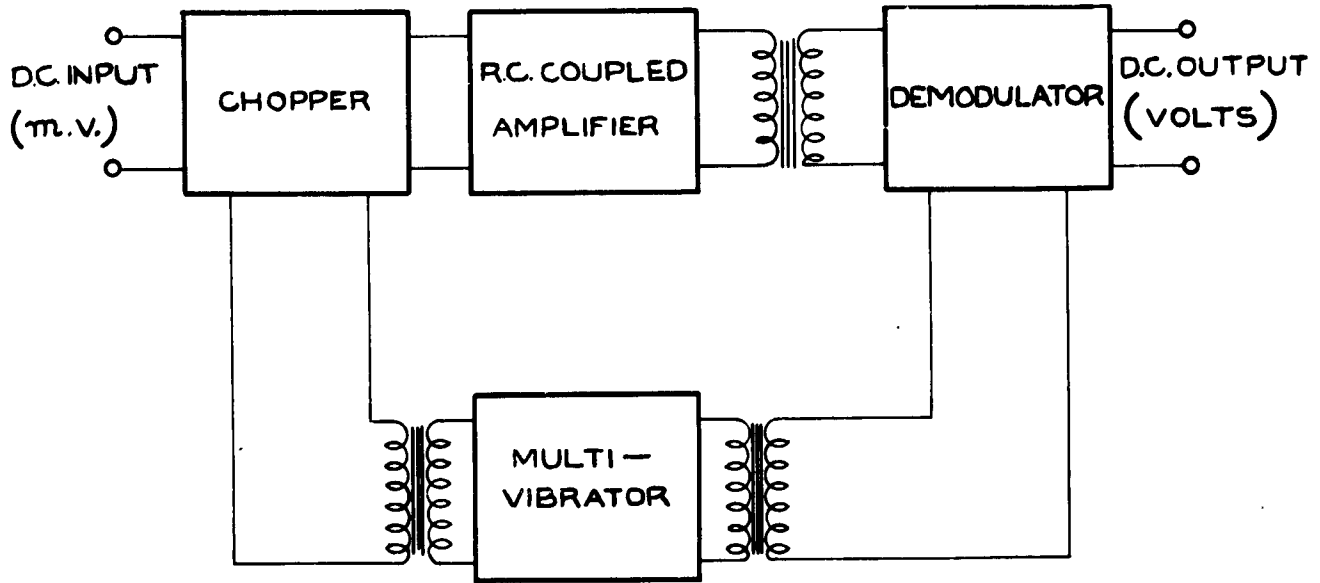

FIG.15 SCHEMATIC DIAGRAM OF AMPLIFIER

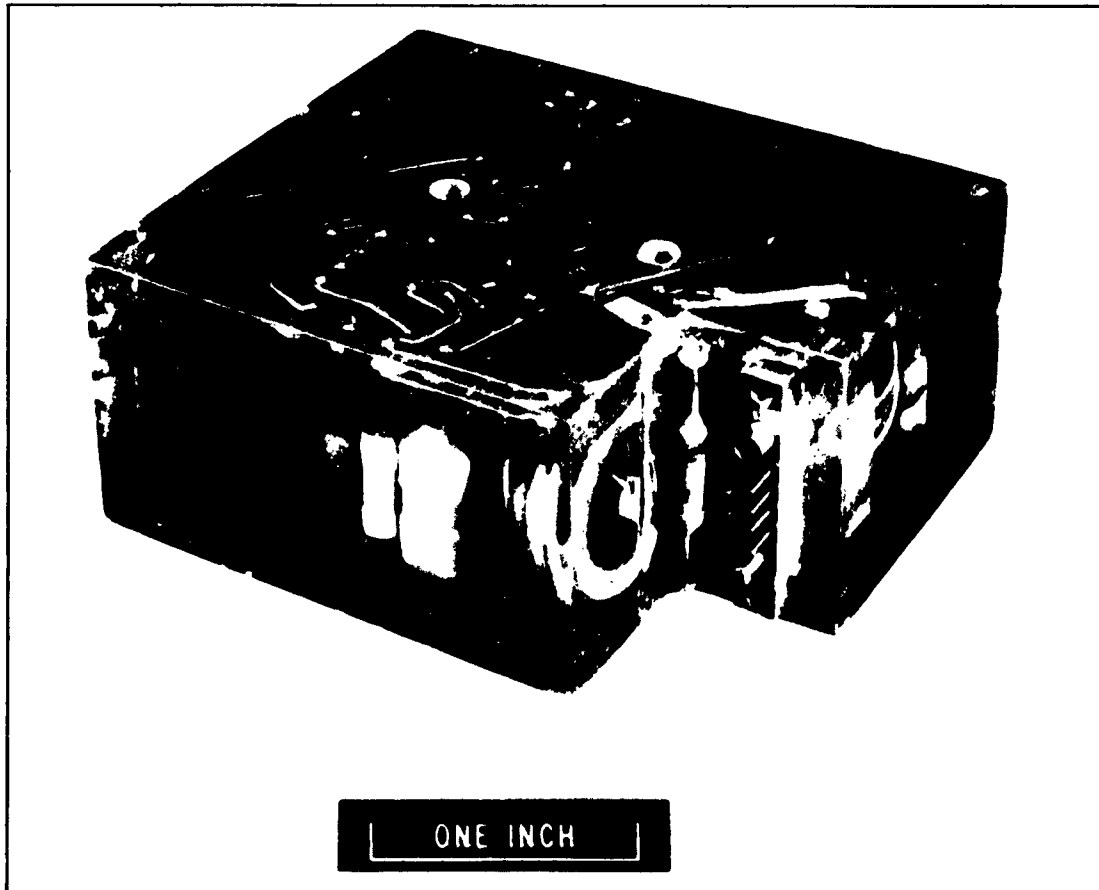

FIG.16 D.C. CHOPPER AMPLIFIER

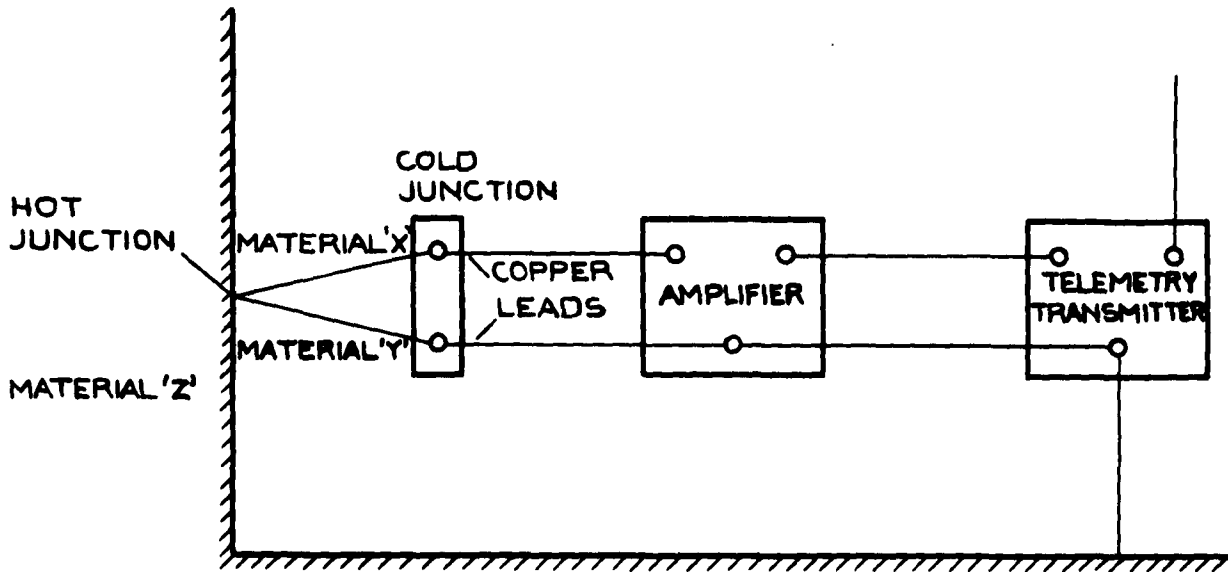

FIG.17 (a) OUTPUT FROM AN XZ THERMOCOUPLE

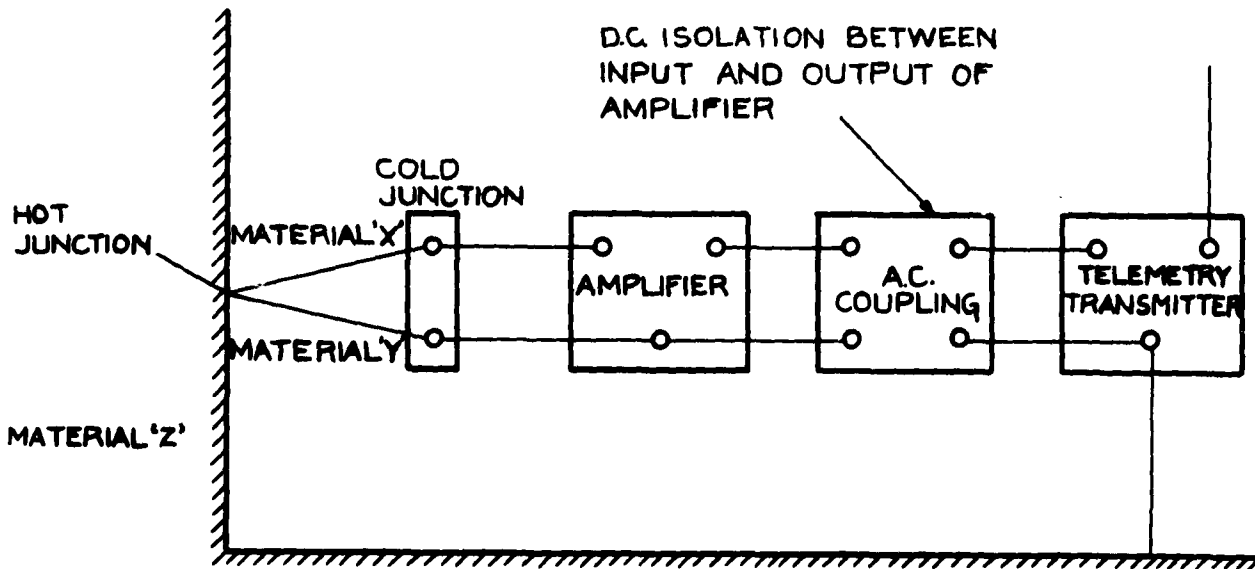

FIG.17 (b) OUTPUT FROM AN XY THERMOCOUPLE

FIG.17 EFFECT OF EARTH AT THE TELEMETRY INPUT TERMINALS ON THE OUTPUT FROM A TWO-WIRE THERMOCOUPLE

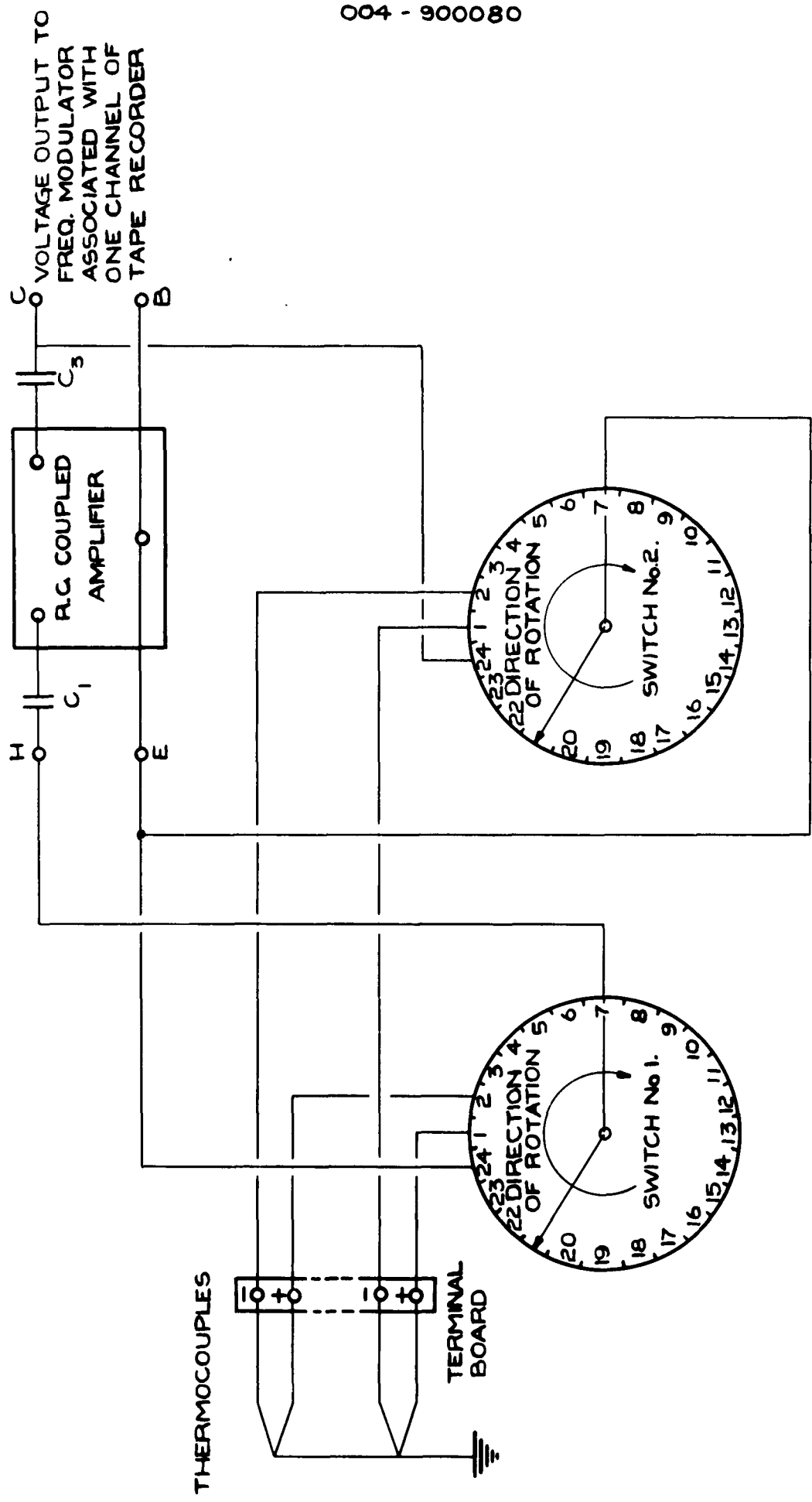

FIG.18 SCHEMATIC DIAGRAM OF THERMOCOUPLE INSTRUMENTATION FOR USE WITH TAPE RECORDER SYSTEMS

Fig.19

004-90081

PLUG 7 WAY  
S.M.R.E.

PLUG 7 WAY  
S.M.R.E.

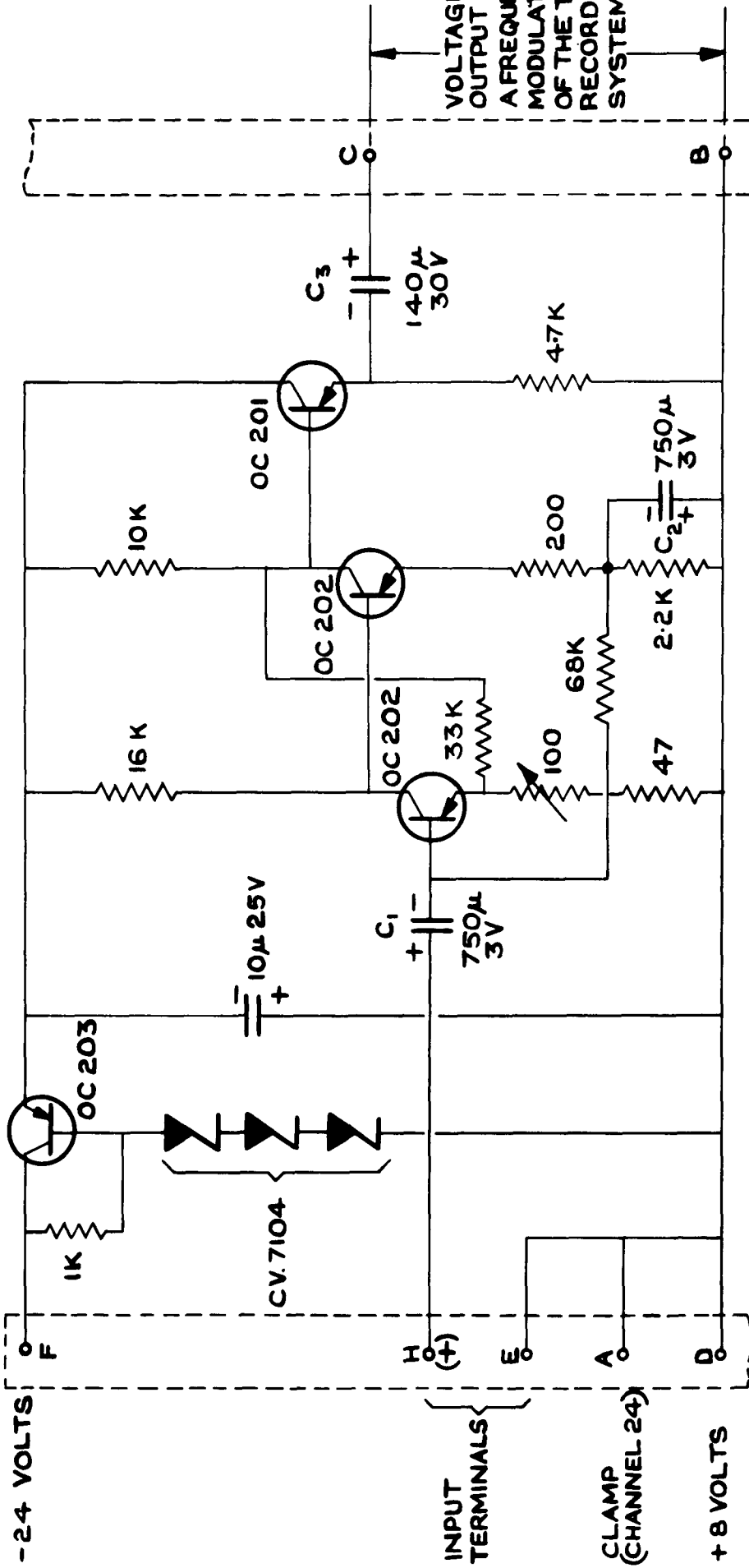
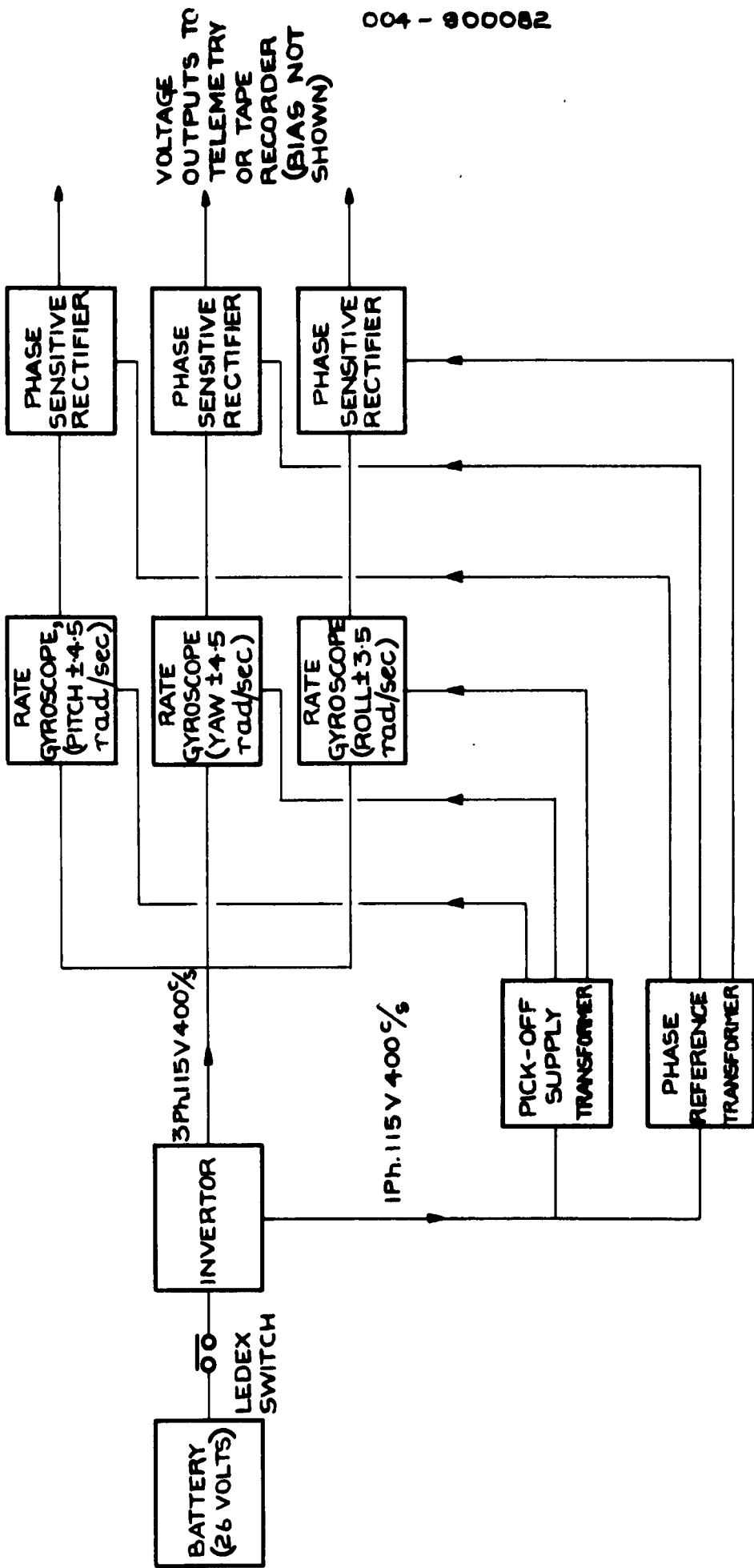

FIG. 19 CIRCUIT DIAGRAM OF THERMOCOUPLE AMPLIFIER  
FOR USE WITH TAPE RECORDER SYSTEMS



004 - 800082

Fig.20

FIG.20 BLOCK DIAGRAM OF RATE-GYROSCOPE INSTALLATION FOR RE-ENTRY HEADS

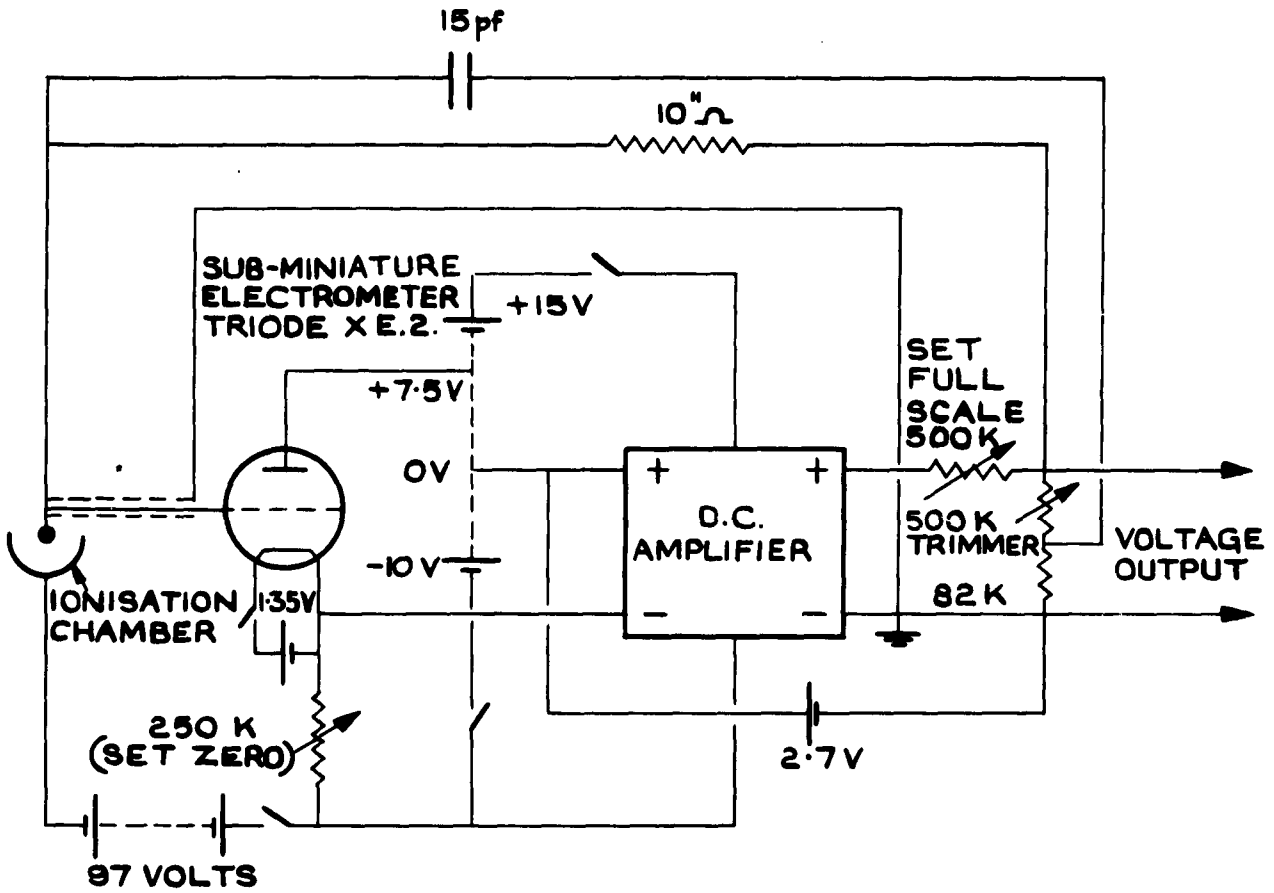

CIRCUIT DIAGRAM

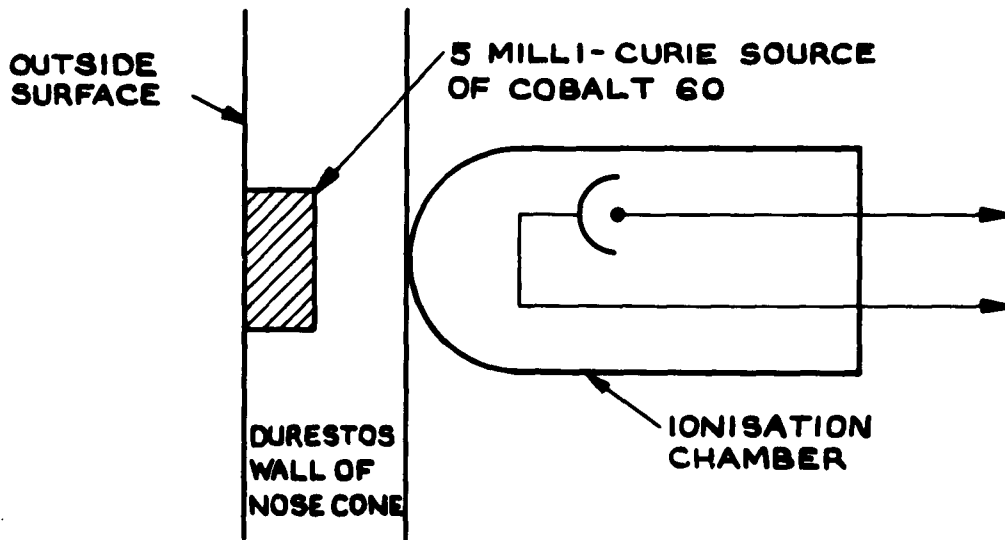
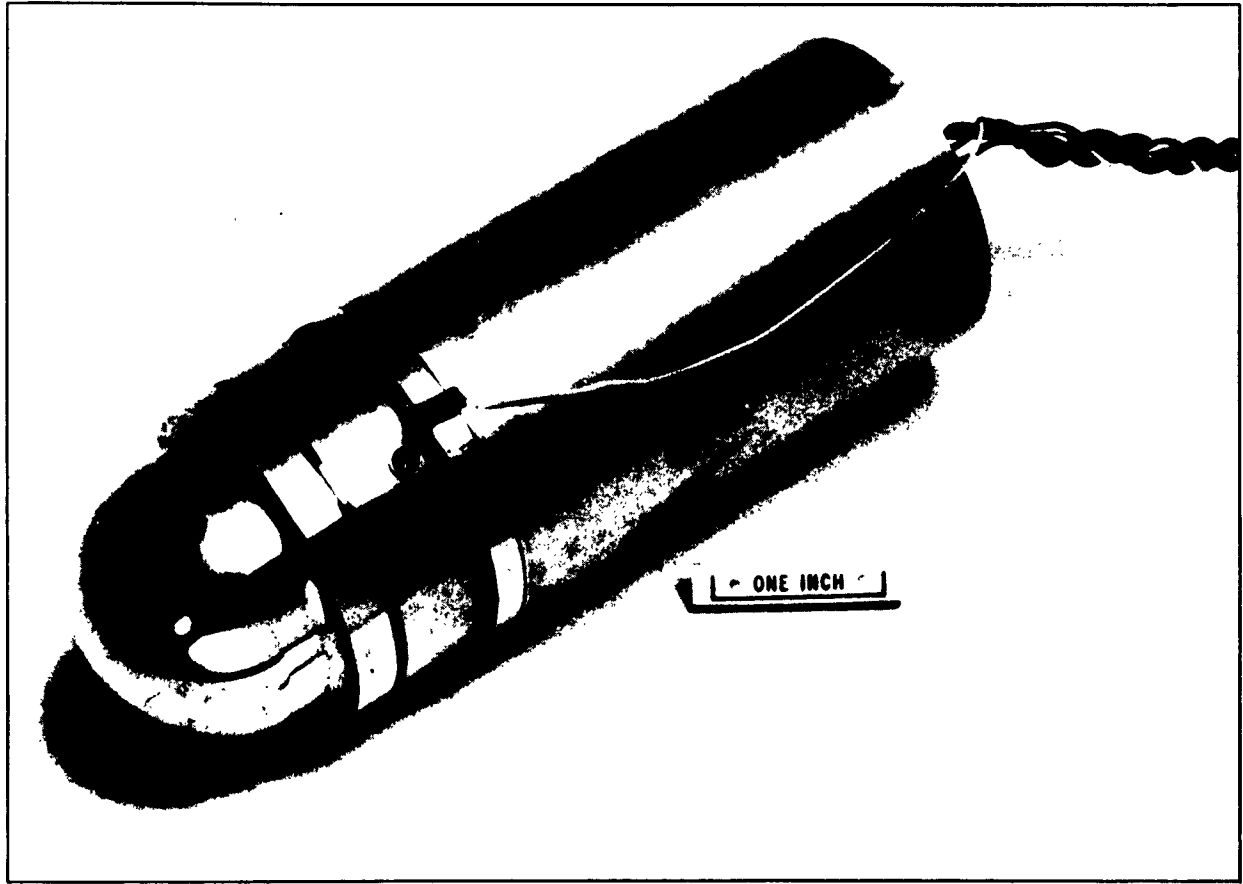

FIG. 21 RADIO-ACTIVE EROSION GAUGE



Ionisation chamber

Fig.22 Detector of radioactive erosion gauge (ionisation chamber and electrometer valve container)

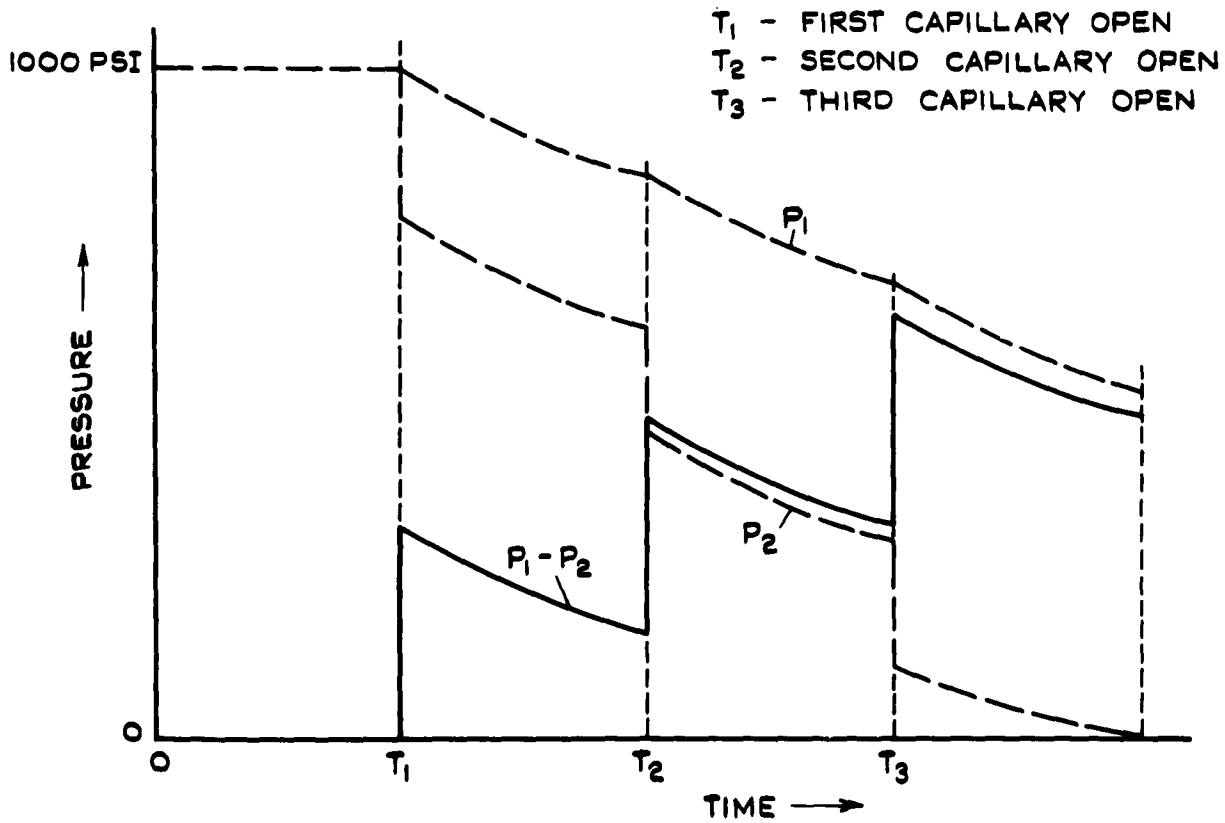
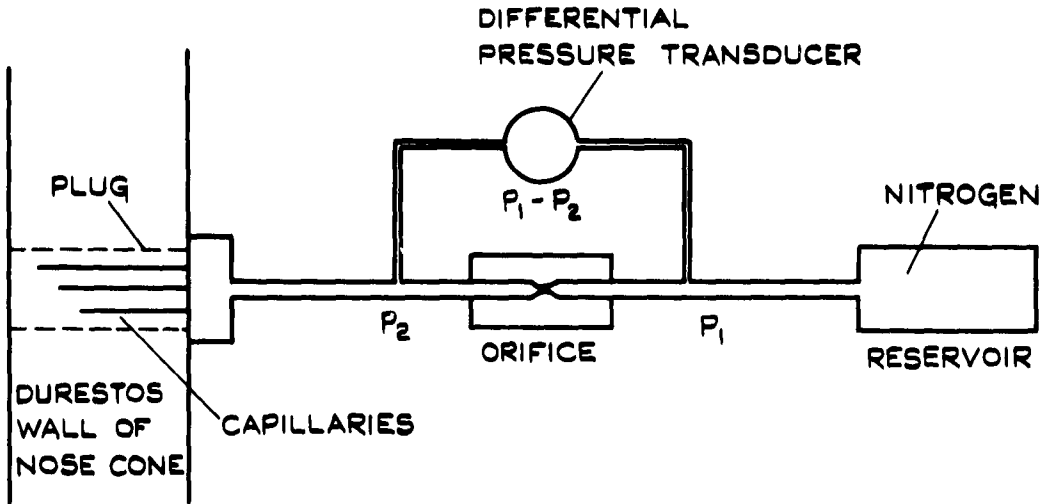

FIG.23 PNEUMATIC EROSION METER



COMPLETED PLUGS



PRINTED CIRCUIT BEFORE ASSEMBLY

PRINTED CIRCUIT LOOPS BROKEN BY EROSION

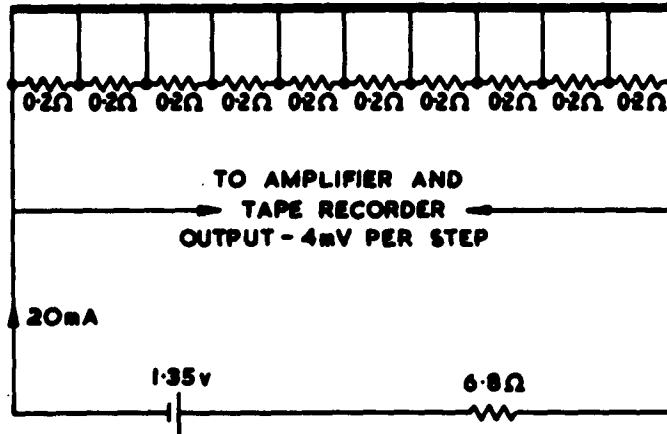
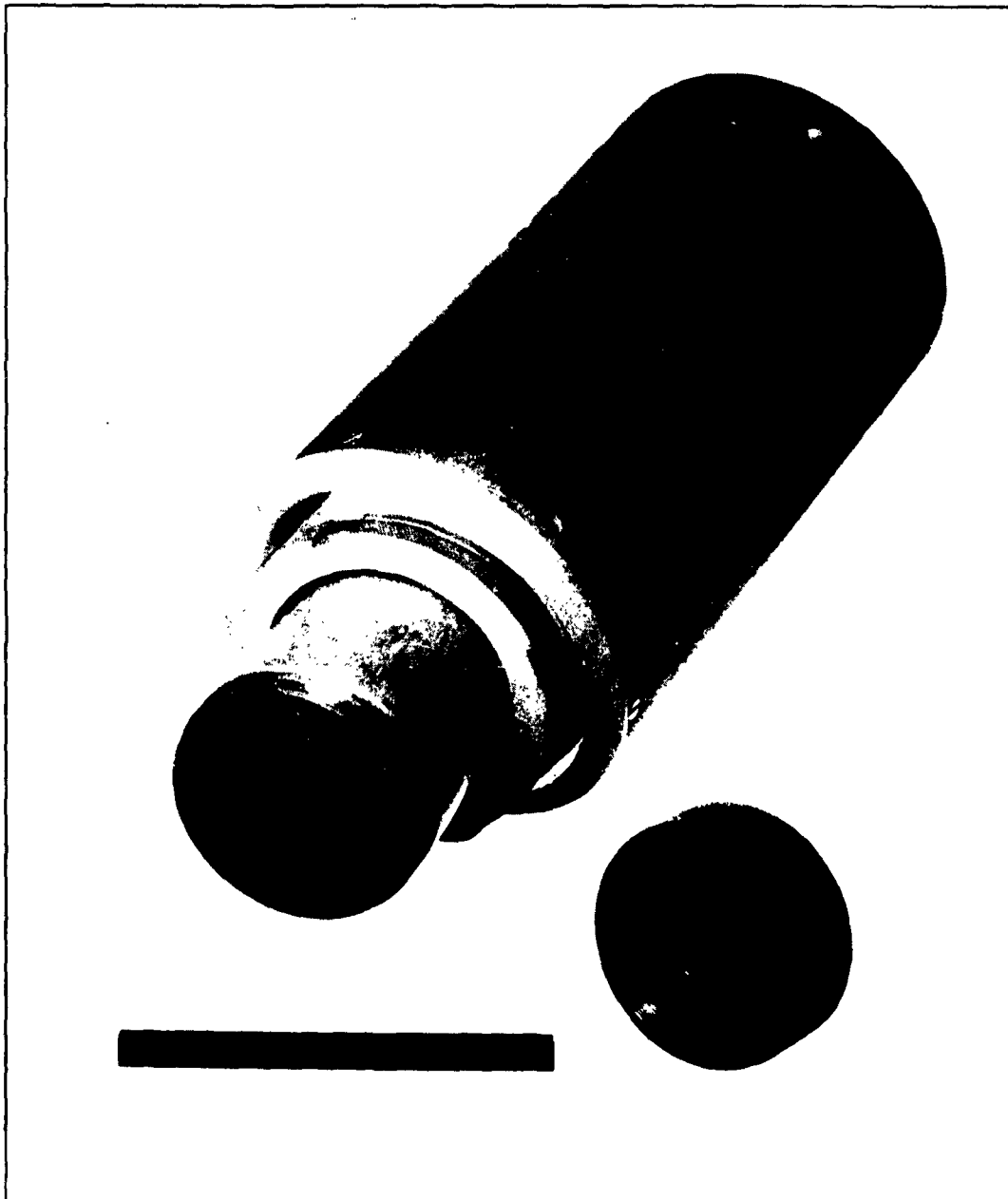

Fig.24 Printed circuit erosion gauges



**Fig.25 Philips gauge unit**





Fig.27 Time delay unit

FREQUENCY DIVIDERS

BLOCKING OSCILLATORS BI-STABLES

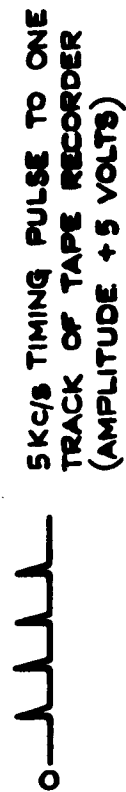
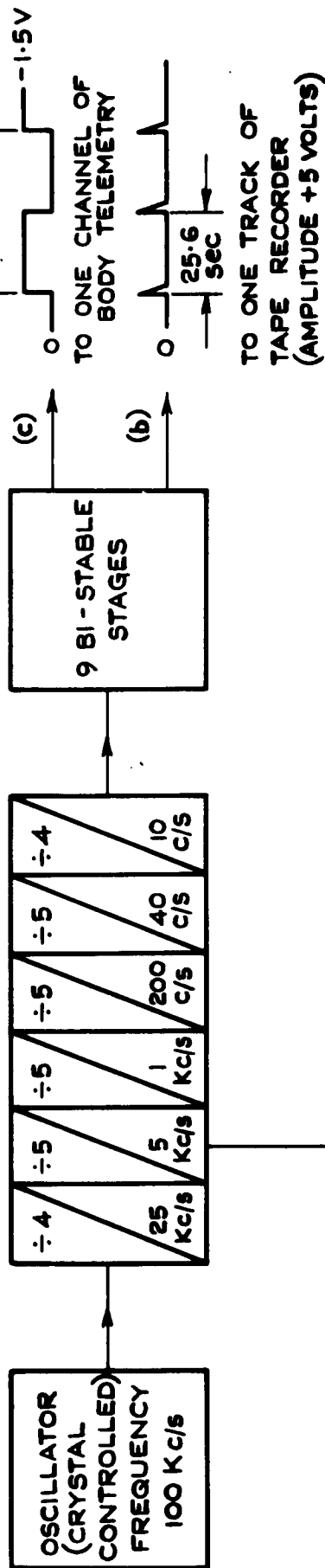

FIG. 28 TIME CORRELATION UNIT

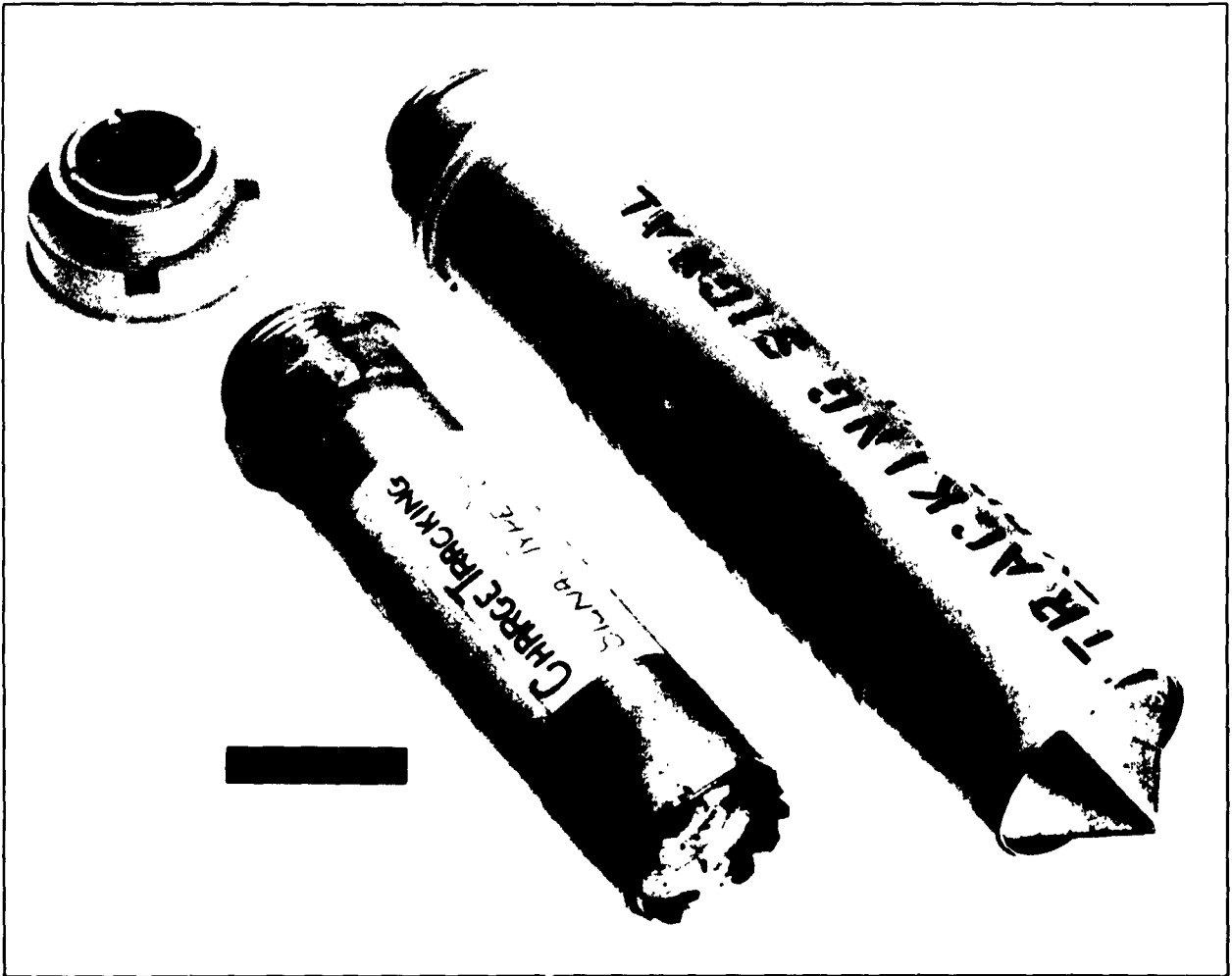

Fig.29 Pyrotechnic flash units. (Type A and B)

**DETACHABLE ABSTRACT CARDS**

These abstract cards are inserted in Technical Reports for the convenience of librarians and others who need to maintain an Information Index.

Detached cards are subject to the same Security Regulations as the parent document, and a record of their location should be made on the inside of the back cover of the parent document.

<p>Dawton, D.I. Knott, F.R. Waterfall, A.P.</p> <p><b>RESTRICTED</b></p> <p>629.19.05 : 629.192.2</p> <p><b>BLACK KNIGHT INSTRUMENTATION SYSTEMS PART 2 HEAD AND SECOND-STAGE INSTRUMENTATION</b></p> <p>Royal Aircraft Establishment Technical Report 66051      February 1966</p> <p>Instrumentation systems used in the heads and second-stage assemblies fitted to Black Knight test vehicles are described in this Report and some information is given on optical tracking aids employed during re-entry of the heads into the atmosphere.</p> <p><b>RESTRICTED</b></p>	<p>Dawton, D.I. Knott, F.R. Waterfall, A.P.</p> <p><b>RESTRICTED</b></p> <p>629.19.05 : 629.192.2</p> <p><b>BLACK KNIGHT INSTRUMENTATION SYSTEMS PART 2 HEAD AND SECOND-STAGE INSTRUMENTATION</b></p> <p>Royal Aircraft Establishment Technical Report 66051      February 1966</p> <p>Instrumentation systems used in the heads and second-stage assemblies fitted to Black Knight test vehicles are described in this Report and some information is given on optical tracking aids employed during re-entry of the heads into the atmosphere.</p> <p><b>RESTRICTED</b></p>
<p>Dawton, D.I. Knott, F.R. Waterfall, A.P.</p> <p><b>RESTRICTED</b></p> <p>629.19.05 : 629.192.2</p> <p><b>BLACK KNIGHT INSTRUMENTATION SYSTEMS PART 2 HEAD AND SECOND-STAGE INSTRUMENTATION</b></p> <p>Royal Aircraft Establishment Technical Report 66051      February 1966</p> <p>Instrumentation systems used in the heads and second-stage assemblies fitted to Black Knight test vehicles are described in this Report and some information is given on optical tracking aids employed during re-entry of the heads into the atmosphere.</p> <p><b>RESTRICTED</b></p>	<p>Dawton, D.I. Knott, F.R. Waterfall, A.P.</p> <p><b>RESTRICTED</b></p> <p>629.19.05 : 629.192.2</p> <p><b>BLACK KNIGHT INSTRUMENTATION SYSTEMS PART 2 HEAD AND SECOND-STAGE INSTRUMENTATION</b></p> <p>Royal Aircraft Establishment Technical Report 66051      February 1966</p> <p>Instrumentation systems used in the heads and second-stage assemblies fitted to Black Knight test vehicles are described in this Report and some information is given on optical tracking aids employed during re-entry of the heads into the atmosphere.</p> <p><b>RESTRICTED</b></p>



*Information Centre  
Knowledge Services*  
**[dstl]** *Porton Down,  
Salisbury  
Wiltshire  
SP4 0JQ  
22060-6218  
Tel: 01980-413753  
Fax: 01980-413970*

Defense Technical Information Center (DTIC)  
8725 John J. Kingman Road, Suit 0944  
Fort Belvoir, VA 22060-6218  
U.S.A.

AD#: AD396859

Date of Search: 17 November 2008

Record Summary: AVIA 6/21621

Title: BLACK KNIGHT instrumentation systems: Pt 2, head to second stage instrumentation  
Availability Open Document, Open Description, Normal Closure before FOI Act: 30 years  
Former reference (Department) TECHNICAL REPORTS 66051  
Held by The National Archives, Kew

This document is now available at the National Archives, Kew, Surrey, United Kingdom.

DTIC has checked the National Archives Catalogue website (<http://www.nationalarchives.gov.uk>) and found the document is available and releasable to the public.

Access to UK public records is governed by statute, namely the Public Records Act, 1958, and the Public Records Act, 1967. The document has been released under the 30 year rule. (The vast majority of records selected for permanent preservation are made available to the public when they are 30 years old. This is commonly referred to as the 30 year rule and was established by the Public Records Act of 1967).

This document may be treated as **UNLIMITED**.