

UNCLASSIFIED

AD NUMBER

AD396965

CLASSIFICATION CHANGES

TO: unclassified

FROM: confidential

LIMITATION CHANGES

TO:  
Approved for public release, distribution unlimited

FROM:  
Distribution authorized to DoD and DoD contractors only; Foreign Government Information; MAR 1966. Other requests shall be referred to British Embassy, 3100 Massachusetts Avenue, NW, Washington, DC 20008.

AUTHORITY

DSTL, AVIA 6/22680, 15 Dec 2008; DSTL, AVIA 6/22680, 15 Dec 2008

THIS PAGE IS UNCLASSIFIED

CONFIDENTIAL

AD 396965

DEFENSE DOCUMENTATION CENTER

FOR

SCIENTIFIC AND TECHNICAL INFORMATION

CAMERON STATION, ALEXANDRIA, VIRGINIA



CONFIDENTIAL

NOTICE: When government or other drawings, specifications or other data are used for any purpose other than in connection with a definitely related government procurement operation, the U. S. Government thereby incurs no responsibility, nor any obligation whatsoever; and the fact that the Government may have formulated, furnished, or in any way supplied the said drawings, specifications, or other data is not to be regarded by implication or otherwise as in any manner licensing the holder or any other person or corporation, or conveying any rights or permission to manufacture, use or sell any patented invention that may in any way be related thereto.

NOTICE:

THIS DOCUMENT CONTAINS INFORMATION  
AFFECTING THE NATIONAL DEFENSE OF  
THE UNITED STATES WITHIN THE MEAN-  
ING OF THE ESPIONAGE LAWS, TITLE 18,  
U.S.C., SECTIONS 793 and 794. THE  
TRANSMISSION OR THE REVELATION OF  
ITS CONTENTS IN ANY MANNER TO AN  
UNAUTHORIZED PERSON IS PROHIBITED  
BY LAW.

UNANNOUNCED

CONFIDENTIAL

TR 66078

MARCH

1966

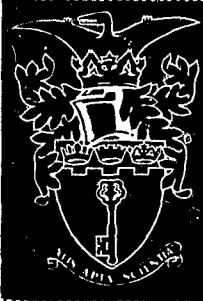

ROYAL AIRCRAFT ESTABLISHMENT  
TECHNICAL REPORT No. 66078

12

SIMULATION OF MULTI-PATH  
DISTORTION OF A MODULATED  
CARRIER SIGNAL USING A  
MICROWAVE NETWORK [C]

by

G. W. Hosie

DDC  
RECEIVED  
SEP 8 1966  
D

1. THIS INFORMATION IS UNCLASSIFIED AND IS TO BE  
USE BY THE RECIPIENT ONLY AND IS NOT TO BE  
CONTROLLED UNDER THE PROVISIONS OF THE  
ENGAGED ON 2. ETC.  
OTHER GOVERNMENT AGENCIES OR  
ANY OTHER WAY WHICH IS A BREACH OF  
CONDITIONS.

2. THE INFORMATION SHOULD BE KEPT  
RULES DESIGNED FOR THE PROTECTION OF  
SECURITY AS THE INFORMATION IS THE PROPERTY OF THE  
GOVERNMENT IN THE UNITED KINGDOM.

3. THE RECIPIENT IS ADVISED THAT THE  
INFORMATION IS UNCLASSIFIED AND IS TO BE  
USE BY THE RECIPIENT ONLY AND IS NOT TO BE  
CONTROLLED UNDER THE PROVISIONS OF THE  
ENGAGED ON 2. ETC.

AD No. 396965  
DDC FILE COPY

MINISTRY OF AVIATION  
FARNBOROUGH HANTS

CONFIDENTIAL EXCLUDED FROM AUTOMATIC  
REGRADING; DOD DIR 5200.10  
DOES NOT APPLY

ACCESSION NO. 127

OFFICE: WHITE SECTION

DDG: DUFF SECTION

UNANNOUNCED

JUSTIFICATION.....

BY.....

DISTRIBUTION/AVAILABILITY CODES

DIST.	AVAIL. and/or SPECIAL
12	



MINISTRY OF AVIATION

THIS DOCUMENT IS THE PROPERTY OF H.M. GOVERNMENT AND  
ATTENTION IS CALLED TO THE PENALTIES ATTACHING TO  
ANY INFRINGEMENT OF THE OFFICIAL SECRETS ACTS, 1911-1939

It is intended for the use of the recipient only, and for communication to such officers under him as may require to be acquainted with its contents in the course of their duties. The officers exercising this power of communication are responsible that such information is imparted with due caution and reserve. Any person other than the authorised holder, upon obtaining possession of this document, by finding or otherwise, should forward it, together with his name and address, in a closed envelope to:-

THE SECRETARY, MINISTRY OF AVIATION, LONDON, W.C.2

Letter postage need not be prepaid, other postage will be refunded. All persons are hereby warned that the unauthorised retention or destruction of this document is an offence against the Official Secrets Acts.

U.D.C. No. 5.001.58 : 621.391.826.2 : 621.391.812.7 : 621.3.029.64

ROYAL AIRCRAFT ESTABLISHMENT

Technical Report No. 66078

(11) Mar 1966

(12) 49p.

(7) ~~SIMULATION OF MULTI-PATH DISTORTION OF A MODULATED CARRIER SIGNAL USING A MICROWAVE NETWORK [C]~~ (8)

(9) Technical rept.

(10) G. W. Hosie

(14) TR-66078

SUMMARY

↓  
Televisually guided air to surface weapons employ radio links to convey guidance pictures from the missile to the aircraft and command signals from the aircraft to the missile. The signals received via these links are subject to fading and distortion due to the simultaneous reception of signals transmitted by the direct path and signals reflected from the ground or other objects.

A laboratory equipment has been designed to enable the effects of dual path propagation to be studied. Descriptions are given of the transmission paths and expressions derived to enable the parameters of the microwave simulator to be determined. The limitations of accurate simulation of multi-path propagation are examined and it is shown that the errors are small where the signal modulation bandwidth does not exceed 100 Mc/s.

↑  
Departmental Reference: WE114

(Title Unclassified)

CONFIDENTIAL

*mt*

310 450

*ef*

CONTENTS

	<u>Page</u>
1 INTRODUCTION	3
2 DISCUSSION OF DUAL PATH RADIO PROPAGATION AND METHODS OF SIMULATION	4
2.1 Propagation in radio links	4
2.2 Simulation in a waveguide network	5
2.3 Limitations of the waveguide network method	6
2.4 Evaluation of simulation parameters	11
3 DESIGN OF THE SIMULATOR	14
3.1 General design requirements	14
3.2 Description of the simulator circuit	16
3.3 Summary of the simulator facilities	19
4 OPERATION OF THE SIMULATOR	20
5 CONCLUSIONS	21
6 ACKNOWLEDGEMENT	21
Appendix A Multi-path propagation of a signal	22
Appendix B Dynamic phase-shifters	25
Symbols	31
Bibliography	33
Illustrations	Figures 1-13
Detachable abstract cards	-

## 1 INTRODUCTION

Air to surface televisually guided weapons require radio links to transmit the target image from the missile to the launch aircraft and to transmit commands from the aircraft to the missile. As well as the direct transmission path between missile and aircraft there exist indirect paths via reflection from the ground and sometimes from prominent objects adjacent to the propagation path. The signal received by the indirect paths will be delayed relative to that received by the direct path by a time proportional to the difference in length of the two paths. The phase of the r.f. components of the indirect signal (with respect to those of the direct path) varies smoothly with variation of the difference in path lengths and the magnitude of the reflected signal has a value dependent on the nature of the terrain or other reflecting object. Thus laboratory simulation of dual path propagation conditions requires circuit elements to simulate the path difference delay, the relative amplitudes, and the phase difference between two signals which are fed to a receiver.

The need for a simulator arises from the complicated effects which are produced by the interaction of the direct and indirect signals in a receiver when the modulating waveform is complex (like a television picture) and the modulation system is anything but simple A.M. It is possible to calculate the distortion of the modulating waveform at the receiver for a few simple wave shapes, for example sine waves, rectangular pulses and linear sawtooth<sup>1</sup>; but these calculations give little idea of the subjective effects on an observer of distortion in a complex scene in a dynamic situation.

Simulation of a complete missile sortie would require very complex equipment but relatively simple apparatus may be designed to simulate any particular short section of a tactical situation.

It is proposed to use the simulator to investigate the subjective effect of the distortion consequent on dual path propagation for a range of radio link designs and tactical situations. The use of the simulator eliminates the difficulties of carrying out controlled experiments in the course of flight trials.

This Report will be confined to a discussion of the transmission paths in the radio link and the simulator. It will be necessary to change the transmitting and receiving equipment for each method of signal modulation and these equipments will be described in separate Reports which will deal with the distortion effects which arise in multi-path propagation for various methods of signal modulation.

## 2 DISCUSSION OF DUAL PATH PROPAGATION AND METHOD OF SIMULATION

As mentioned in the previous section signals reach the radio link receivers by both direct and indirect paths, and the frequency, phase and amplitude of the indirect signal will differ from those of the direct signal. In this section the propagation effects which take place in an idealised situation are examined and then compared with those which take place in waveguide circuits which may be used to simulate this idealised situation. Finally expressions are derived to enable the magnitude of the main differences between indirect and direct signals to be calculated.

A real situation of an aircraft and missile flying over terrain would involve many complex effects due to the rough surface of the earth and the perturbations of the missile and aircraft flight paths due to aerodynamic buffeting and structural flexure. The situation considered is idealised in that the terrain is considered to be flat and the motions of the transmitter and receiver to be smooth.

### 2.1 Propagation in radio links

Firstly the propagation paths in the radio link between two low flying vehicles must be considered in order to determine the requirements of the simulator. The paths which are considered are shown in Fig.1 where there is a direct and one other path due to the signal being reflected from a plane earth and where there is a separating velocity between the terminals of the radio link.

The instantaneous voltage of the received unmodulated signal has been derived in Appendix A for such a link in terms of the transmitted power, the wavelength of the carrier, the gains of the transmitting and receiving aerials in the direction of the transmission paths, the lengths of the direct and reflected transmission paths and the power reflection coefficient of the reflecting surface. This instantaneous voltage is the vectorial sum of the amplitude of the signals received from each path.

Where there is a separating velocity between the terminals of the radio link, then as the difference in the relative lengths of the transmission paths changes by one wavelength of the carrier, the relative phase between the direct and reflected carrier will change progressively through  $360^\circ$ . The received signal, which is the vectorial sum of the direct and indirect path waveforms, will vary cyclically in amplitude at a rate determined by the rate of change of the relative phase of the waveforms. This rate of change of the relative phase between the multi-path signals is the differential Doppler shift frequency and is generally referred to as the fading rate of the signal.

The signals in the direct and reflected paths suffer different Doppler shifts of the received frequency and although these shifts are high compared with the differential Doppler shift between the two signal paths they are still very small compared with the signal frequency. The effects of the Doppler shift due to a direct path can readily be corrected by retuning the receiver to the Doppler shifted frequency but there still remains the difference in Doppler shift of signal where there is a reflected path. There will be little loss of accuracy if only a differential Doppler shift frequency term is added to the reflected path frequency term, and it is assumed that the Doppler shift term of the direct path signal is corrected by retuning the receiver. Thus the instantaneous amplitude of the received signal can be expressed in the form given in equation (A.7) where there is a separating velocity between the transmitting and receiving stations and where the propagated signal is unmodulated.

A modulated signal can be considered as a carrier plus a set of side-bands and each side-band will be affected as indicated in expression (A.7). Thus each side-band will have a Doppler shift proportional to its radio frequency and the fading rate will be higher for the higher frequency side bands than for those of lower frequency. As explained later this effect leads to difficulty in the simulation of dual path propagation of broad band signals.

## 2.2 Simulation in a waveguide network

From the description of dual path propagation given above it will be seen that to simulate this condition a means must be found of delaying and frequency shifting a radio frequency signal in order to reproduce the effects of interaction of the direct and indirect signals. For the delaying component it is convenient to use waveguide, since the transmission loss is relatively small. For the phase shifting component some form of single side-band modulator may be employed.

If steady state low frequency signals are used to control the phase shifter it is possible to reproduce the dual path effect over any given small part of the trajectory but simulation of an entire sortie would require simultaneous variation of the power of the direct and indirect signals as well as continuous variation of the fade frequency.

A block diagram of the waveguide network used is shown in Fig.2 and a schematic diagram is shown in Fig.3. A photograph of the complete equipment is shown in Fig.4.

The indirect signal arm which simulates the reflected path consists of a dynamic phase-shifter, a delay section and a variable attenuator which is called

the ground loss attenuator. The dynamic phase-shifter applies a constant rate of phase or frequency shift to the indirect arm input signal and the rate of change of phase applied is controlled by an external low frequency oscillator to simulate the differential Doppler shift frequency of the radio link. The delay section is a length of waveguide having a group delay equal to the relative delay between the direct and reflected signals of the radio link. The function of the variable attenuator is to control the relative amplitudes of the direct and indirect signals to give the depth of fading required.

The direct arm consists of a short length of waveguide which includes an attenuator to equalise the losses of the dynamic phase-shifter and the delay section in the indirect signal arm. In addition, a variable phase-shifter is included in the direct arm and this is useful for manual control of the relative phases of the signals applied to the summing circuit.

The simulator arm losses can be readily equalised, when the indirect arm or "ground loss" attenuator is set to its zero setting, by adjusting the direct arm attenuator until 100% fading of a carrier signal is indicated at the output of the summing circuit. The calibration of the ground loss attenuator may then be used to determine the relative amplitudes of the direct and indirect arm waveforms at the summing unit and hence the depth of fading of the signal at the receiver.

An attenuator in the common receiver arm is used to control the amplitude of the signal fed to the receiver. This is adjusted so that the total attenuation of the signal transmitted to the receiver via the direct arm is equivalent to the attenuation of the signal transmitted via the direct path of the radio link.

The propagation of an unmodulated carrier through the simulator is summarised in Section 2.4 and discussed in Appendix A; the instantaneous voltage of the waveform at the receiver is given in equation (A.9). This equation may be compared directly with equation (A.7) which gives the instantaneous voltage at the receiver of the radio link and from these equations it is possible to derive values for the simulator transmission path parameters in terms of the parameters of the transmission paths of the radio link.

### 2.3 Limitations of the waveguide network

#### 2.3.1 Nature of the limitations

The signal at the receiver of the simulator can be made to reproduce accurately the signal at the receiver of the radio link when the signal propagated in the direct and reflected paths is unmodulated. However when the signal

propagated in the radio link is modulated, the simulator does not reproduce accurately the modulated signal at the input to the receiver. The failure of the simulator to reproduce accurately the modulated signal is due to differential frequency effects which increase as the bandwidth of the signal is increased. The effects have two main causes; the dynamic phase shifter produces an equal frequency shift for all the r.f. components and the delay time in the waveguide is not constant for all components of a modulated carrier.

### 2.3.2 Errors in simulation of the fading frequency

The fading frequency of the carrier waveform is discussed in Appendix A and its value is given by equation (A.6). There it is shown that the fading rate is proportional to the radio frequency of the signal. Thus with a modulated signal each r.f. component of the signal will have a different fading rate.

In the simulator the fading rate is reproduced by the dynamic phase-shifter which gives a constant frequency shift to all radio frequency components of the modulated signal. Hence with the dynamic phase-shifter set to give the correct fading rate for the carrier frequency component of a modulated signal, the fading rate will be too high for the lower side-band components (i.e. components having a frequency lower than the carrier frequency) and similarly the fading rate will be too low for the fading rate of the upper side-band components. This error is generally small compared with the fading rate of the carrier as will be shown in the following example.

If a signal modulates a carrier of frequency 10 Gc/s so that there is an upper side-band component which is displaced from the carrier signal by 50 Mc/s, then when the fading rate of the carrier is 200 c/s, the fading rate of the upper side-band is 201 c/s in the real situation.

### 2.3.3 Errors due to delay distortion

Where long lengths of waveguides are employed and where the bandwidth of the signal is large, there is a possibility of introducing appreciable phase distortion of a modulated signal propagated through such a length of waveguide.

Let us consider a single waveguide path and a single free space propagation path. These two paths have equivalent delays when the times required to propagate a pulse of r.f. from the input end of either path to the output end of the same path are identical. That is, this time is given by

$$t = l/V_g = R_0/c \quad (1)$$

where  $\ell$  is the length of waveguide,  $V_g$  is the group velocity,  $R_0$  is the length of the free space path, and  $c$  is the velocity of light.  $V_g$  can be related to the angular frequency and the type of waveguide by

$$V_g = c(1 - X^2)^{\frac{1}{2}} \quad (2)$$

where  $X$  is the ratio  $w_c/w_s$ ,  $w_c$  being the cut-off angular frequency of the waveguide and  $w_s$  is the angular frequency of the carrier.

With free space propagation all r.f. components of the signal are delayed by an amount which is proportional to the path length and thus there is a linear phase-shift with frequency and hence the envelope of the r.f. waveform is not distorted.

With propagation in the waveguide, the relationship between phase shift and frequency is not linear. Where the waveguide path and the free space path have identical times of transmission for the midband frequency of the r.f. transmission bandwidth, the difference in phase ( $\Delta\phi$ ) at the output of the two paths for any other r.f. component of the signal is a non-linear function of frequency. The phase difference is a measure of the time delay of the side-band component compared with that of the carrier after transmission through a length of waveguide.

Where there are two symmetrical side-bands, the quantity ( $2\Delta\phi$ ) is a measure of the relative time delay between the side-bands after transmission through the waveguide and as such is a measure of the distortion introduced by the waveguide.

Such delay distortion for double side-band amplitude modulation systems has been considered by A.E. Karbowski<sup>2</sup> for propagation in long waveguides and he has determined the useful bandwidth ( $f_b$ ) of such waveguides in terms of the delay distortion term ( $\Delta\phi$ ) and this bandwidth can be expressed as

$$f_b = \left[ \frac{2f_s c}{\pi\ell} \right]^{\frac{1}{2}} \cdot \frac{(1 - X^2)}{X} \cdot (\Delta\phi)^{\frac{1}{2}} \quad (3)$$

It is difficult to assign a discrete value to the delay distortion term especially when different methods of signal modulation may be employed in the circuit. In communication systems where a high value of distortion may be tolerated on the highest modulating frequencies, the maximum values of bandwidth of the waveguide circuit are sometimes given where the delay distortion term is given a value of  $90^\circ$ .

In order to determine the relationship between the group delay the waveguide bandwidth ( $f_p$ ), the length of waveguide employed and the operating frequency this has been computed for WG 16 waveguide where an arbitrary value of  $45^\circ$  has been assigned to the delay distortion term ( $\Delta\phi$ ). The results are shown in Fig.5. It will be seen that for a carrier frequency of 9.3 Gc/s, and a length of 100 metres of waveguide the bandwidth is about 100 Mc/s. This bandwidth varies as the inverse square root of the length of line.

#### 2.3.4 Selective fading within the modulation bandwidth

In the radio link, where there is a direct and one reflecting path of effective lengths  $R_1$  and  $R_2$  respectively, a wide band signal at the receiver suffers selective fading due to the differences in the lengths of the two paths. This effect can be demonstrated by resolving the wide band signal into its Fourier components and when  $w(R_2 - R_1)/c$  equals  $2n\pi$  the individual waves of the two paths reinforce each other, and when  $w(R_2 - R_1)/c$  equals  $(2n + 1)\pi$  the individual waves destructively interfere with each other.

In the simulator which has a difference in the lengths of the two paths so that the waveguides have lengths of  $l_1$  and  $l_2$  for the direct and indirect paths, which gives the same differential propagation time as in the radio link, then the individual Fourier components reinforce and destructively interfere with each other when  $w(l_2 - l_1)/v_p$  equals  $2n\pi$  and  $(2n + 1)\pi$  respectively. The phase velocity of the waves propagated in a waveguide is given by:-

$$v_p = c / \left[ 1 - \left( \frac{w}{c} \right)^2 \right]^{\frac{1}{2}} .$$

As this is a non-linear function with frequency, the selective fading with frequency will be different in the waveguide from that in the radio link. The change of phase difference with frequency due to the two paths will be less in the simulator than for the radio link.

#### 2.3.5 Discussion of the limitations of the waveguide network

The differences which arise in the typical transmission paths of a radio link compared with the idealised case which has been postulated here are likely to be large compared with the differential effects which have been discussed in this section. In particular the variations in the ground contour are likely to give quite large changes of relative phase and delay between the signals received via the two paths of the radio link.

It has been shown that the differential Doppler frequency shift over the modulation bandwidth of the signal can give rise to a form of selective side-band fading due to the difference in the fading rates of the side-band components. This change of fading rate is quite small for moderate bandwidth signals and may amount to  $\pm 0.5\%$  for an X band carrier modulated with a 50 Mc/s waveform. It is considered that this small difference will have little subjective significance unless the fading is sufficiently deep to give complete suppression of the carrier signal.

Due to the dispersive medium of the waveguide, differences occur in the transmission times of the different frequency components of the signal in the waveguide and this gives rise to an envelope distortion of the modulation waveform. It is difficult to assess the nature or magnitude of the distortion of the demodulated signal especially where various methods of signal modulation might be employed. The relative phase-shift ( $\Delta\phi$ ) of the highest side-band component compared with the phase-shift in the corresponding free-space path is generally taken as the measure of the delay distortion and a figure of  $45^\circ$  has been chosen in Fig.5 to determine the bandwidth of WG 16 waveguide. The bandwidth varies inversely with the square root of the length of waveguide employed, as the square root of the relative phase-shift and as a non-linear function of the ratio of the carrier and cut-off frequencies of the waveguide. At the frequency of 9.3 Gc/s the bandwidth of 100 metres of WG 16 waveguide is about 100 Mc/s where the relative phase-shift due to differential delay is  $45^\circ$ .

In both the radio link and in the simulator there is relative phase shift with frequency which will give a phase shift to the fading frequency for the various frequency components of the modulated signal. This change of phase will be less marked in the case of waveguide propagation due to the greater phase velocity in the waveguide circuit. In the case of deep fading of the received signal it would be expected that the fading would be more complete in the case of modulated signal in the simulator due to this effect and also because of the difference in the rate of side-band fading which was discussed above.

The practical limit which has been put on the simulator is in the length of the delay section which has a maximum length of 100 metres. This gives, at a frequency of 9.3 Gc/s a maximum group delay of about 450 nanoseconds with a circuit bandwidth of about 100 Mc/s for this group delay. The bandwidth increases inversely as the square root of the waveguide length and in practice these conditions impose few restrictions in the simulation of low level attack sorties. The requirements for the early part of high level stand-off sorties however cannot

usefully be met with this type of circuit due mainly to the limitations of the delay circuit.

In the simulator, the relative delay time between the two paths and the fading rate of the carrier frequency can be controlled independently of the carrier frequency. The bandwidth of the signal in the simulator depends on the carrier frequency, but provided that this bandwidth is such as to make the delay distortion term ( $\Delta\phi$ ) small, the carrier frequency is not critical. Hence, in investigating the effects of the path transmission, the carrier frequency in the simulator need not be that of the radio link. Thus the simulator, using a fixed frequency, can simulate all radio link carrier frequencies which have a fading rate which can be simulated by the dynamic phase-shifter, providing the relative delay between the two paths is such that the bandwidth requirements of the simulator are satisfied.

#### 2.4 Evaluation of the simulator parameters

##### 2.4.1 General

Within the limits which have been discussed in Section 2.3, it is permissible to use the equations derived in Appendix A for the instantaneous amplitudes of the received signals in the radio link and in the simulator to determine values of the simulator parameters in terms of the postulated radio link path parameters when a modulated signal is propagated. It will be assumed that the simulator is adjusted so that the signal at the receiver of the simulator is equal to that of the radio link and that the relative delay ( $t_2$ ) of modulation information is the same in both cases.

From Appendix A, equation (A.7) we have the instantaneous amplitude of the receiver radio link signal ( $a_L$ ) is given by

$$a_L = \left[ \frac{\lambda (2P_L Z_L G_{T1} G_{R1})^{\frac{1}{2}}}{4\pi R_1} \right] \cdot \left[ \cos w_L t + \frac{(G_{T2} G_{R2} \rho)^{\frac{1}{2}} R_1}{(G_{T1} G_{R1})^{\frac{1}{2}} R_2} \cos(w_L + w_F)(t - t_2) \right].$$

..... (4)

The simulator is assumed to be set up so that the gains of the dynamic phase-shifter and the delay section in the indirect arm are equal to the gain in the direct arm such that  $B_E = B_A B_B$ . Then the instantaneous amplitude of the signal at the simulator receiver is given by

$$a_s = (B_C B_E P_S Z)^{\frac{1}{2}} [\cos w_s t + (B_G)^{\frac{1}{2}} \cos(w_s + w_f)(t - t_2)] \quad (5)$$

- where
- $B_A$  is the signal power gain in the microwave dynamic phase-shift
  - $B_B$  is the power gain in the microwave delay section
  - $B_C$  is the power gain in the simulator receiver arm
  - $B_E$  is the power gain in the simulator direct path arm
  - $B_G$  is the power gain of the ground loss attenuator
  - $G_{R1}$  is the power gain of the receiver aerial in the direction of the direct path
  - $G_{R2}$  is the power gain of the receiver aerial in the direction of the reflected path
  - $G_{T1}$  is the power gain of the transmitted aerial in the direction of the direct path
  - $G_{T2}$  is the power gain of the transmitting aerial in the direction of the reflected path
  - $P_L$  is the transmitted power in the radio link
  - $P_S$  is the total power input to the simulator
  - $R_1$  is the length of the direct radio link path
  - $R_2$  is the length of the reflected radio link path
  - $t$  is time
  - $t_2$  is the relative time delay between the direct and reflected paths of the waveguide arms for the modulation information
  - $Z$  is the impedance of the feeder to the simulator receiver
  - $Z_L$  is the impedance of the feeder to the radio link receiver
  - $\rho$  is the ground reflection power coefficient
  - $\lambda$  is the wavelength of the carrier.

The terms in these equations will now be compared with one another to establish values of the simulator parameters in terms of the radio link signal path parameters.

#### 2.4.2 Total gain of the signal in the direct arm

If the first block of terms in equations (4) and (5) are compared then if they are of equal value, the direct arm signal total gain is

$$B_E B_C = \frac{2\lambda^2 G_{T1} G_{R1} P_L Z_L}{(4\pi R_1)^2 P_S Z} \quad (6)$$

The value of  $B_E$  the equalising attenuator has been found when setting up the simulator and hence when the value of  $B_E B_C$  is known,  $B_C$  can be readily found.

Although the equations given in Sections 2.4.1 and 2.4.2 enable the mean powers of the direct and indirect signals to be calculated from the fundamental parameters of the system being simulated, it is often possible and more convenient simply to adjust the relative powers of the two signals in accordance with experimental data and to set the absolute level of the direct signal in relation to a calculated or observed value of the received signal to noise ratio. This method avoids any absolute measurements of signal power and receiver noise factor and sets the signal level accurately in relation to the receiver threshold.

#### 2.4.3 Length of waveguide forming the delay section

The delay ( $t_2$ ) of the reflected path signal with respect to the direct path signal in the radio link can be found from the differences in the path lengths and the velocity of signal propagation ( $c$ ) as

$$t_2 = (R_2 - R_1)/c \quad (7)$$

The required delay ( $t_2$ ) to be used in the simulator can be found from the differences in waveguide lengths of the two arms and from the group velocity ( $v_g$ ) within the waveguide. Then, where ( $l_1$ ) and ( $l_2$ ) are the lengths of the direct and indirect paths respectively, this delay will be

$$t_2 = (l_2 - l_1)/v_g \quad (8)$$

Where equation (7) and (8) are equal, then the length of waveguide required will be

$$l_2 = \left[ v_g (R_2 - R_1)/c \right] + l_1 \quad (9)$$

#### 2.4.4 The ground loss attenuator

The ground loss attenuator determines the relative amplitudes of the direct and indirect path signals and hence the depth of signal fading. The gain of this attenuator can be obtained from inspection of equation (4) and (5) as

$$B_G = \frac{G_{T2} G_{R2} \rho(R_1)^2}{G_{T1} G_{R1} (R_2)^2} \cdot \quad (10)$$

The depth of fading is a maximum when the attenuator gain is unity.

#### 2.4.5 The fading frequency

Where the separating velocities measured over the direct ( $v_1$ ) and the reflected paths ( $v_2$ ) are known, then the angular fading rate can be found from

$$w_f = w_L(v_2 - v_1)/c \cdot \quad (11)$$

Where only the geometry of the flight path is known then<sup>3</sup>

$$w_f = \left[ 4\pi/(R^2\lambda) \right] \left[ R h_t (dh_r/dt) + R h_r (dh_t/dt) - h_r h_t (dR/dt) \right] \quad (12)$$

where  $R$  is the horizontal range between transmitter and receiver

$h_r$  is the height of receiver above the ground

$h_t$  is the height of the transmitter above the ground.

In the simulator, the fading frequency is controlled by an external oscillator which drives the dynamic phase-shifter, and the oscillator has a frequency which is half the required fading frequency when the Cacheris type dynamic phase-shifter is used.

### 3 DESIGN OF THE SIMULATOR

#### 3.1 General design requirements

Ideally one would like the equipment to be capable of simulating dual path propagation conditions in a wide range of radio link systems, over a wide range of aircraft and missile separation speeds over terrain of different types and for modulating signals over a wide range of bandwidths. In practice it is necessary make some restrictions in order to obtain equipment of reasonable size and complexity. The most severe of these restrictions relates to the nature of the terrain since it is readily feasible to simulate only flat ground having a range of reflection coefficients. Fortunately any other type of reflecting surface is likely to give reflections which are less coherent and so in all probability less serious in their subjective effects than a smooth surface.

The main characteristics of the simulator which need to be determined before the design can proceed are the length of the delay path, the relative strengths of the direct and the indirect signals, the range of rates of change of phase of the r.f. carrier (or fade frequency), the range of absolute values of direct signal power required at the receivers systems under test, and the range of system bandwidths which must be accommodated. These characteristics are determined in relation to the range of real situations which it is desired to simulate and each of the characteristics will now be briefly considered.

### 3.1.1 Path difference

Fig.6 shows approximated trajectories of aircraft and missile for typical cases of release at low altitude and high altitude respectively.

#### (a) Low level launch

For the tactical situation following launch at low altitude (see Fig.6(a)) during the latter half of the navigational phase and during the homing phase, the path difference gives a relative delay between the direct and reflected path signals varying from about  $50 \times 10^{-9}$  seconds down to zero (see Fig.7). Velocities of both missile and aircraft are assumed to be 1000 ft per second and the missile dives at 5 miles from the target.

#### (b) High level launch

For situations following a launch at high altitude the larger path differences which arise in the trajectory shown in Fig.6(b) give relative delays between the direct and reflected path signal varying from some  $800 \times 10^{-9}$  seconds down to zero (see Figs.6 and 7).

### 3.1.2 Relative power of direct and indirect signals

The tactical situation which involves the largest value of indirect signal is flight over smooth sea and in this case the indirect signal power can become almost equal to that of the direct signal. Flight over areas of low reflection coefficient terrain results in indirect signals 20 to 30 dB less than the direct signal power.

### 3.1.3 The fade frequency of the carrier signal

The value of the fade frequency is proportional to the radio frequency and is mainly a function of the rate of change of the aircraft to missile range and to the rate of change of height of the missile. (See Section 2.4.5). For a missile launched at low altitude, the rate of fading at X band is less than

10 c/s (see Fig.8) during most of the mid-course navigation and terminal homing to the target, giving a maximum rate of under 40 c/s at Q band.

For high altitude launch situations, the fading rate is generally higher and the maximum rate for X band signals is about 200 c/s (see Fig.8) where the homing phase is 5 miles from the target.

For the case of the missile and aircraft in level flight and a radio link frequency in the UHF bands, the fading cycle would occupy many seconds and thus ideally the simulator needs to be able to provide fade frequencies from a small fraction of one c/s to about 1000 c/s.

#### 3.1.4 Range of absolute values of direct signal power

Most of the radio link systems considered for weapon applications have a definite signal threshold in the region of 6 dB to 15 dB above receiver r.f. noise. The output of the simulator needs to be capable of being attenuated below this level so that fading to values below the threshold can be investigated. Since the power available for airborne transmitters is restricted by weight and economic considerations the useful upper limit of signal output from the simulator is about 20 dB above the threshold value. The value of the receiver noise power will be 6 dB to 12 dB above thermal noise in the system bandwidth which is considered below.

#### 3.1.5 Range of system bandwidth

Radio link systems for television weapons are required to handle video signals of bandwidth in the range from 1 Mc/s to 5 Mc/s. The use of bandwidth expansion techniques leads to r.f. system bandwidths in the range 2 Mc/s to 100 Mc/s but a practical upper limit at present is probably 50 Mc/s. The r.f. transmitter in the simulator is thus required to be coherent over periods long compared with a differential path delay of some  $500 \times 10^{-9}$  seconds and the transmission paths must have a bandwidth of at least 50 Mc/s.

### 3.2 Description of the simulator circuit

The circuit of the simulator is similar to that already discussed and has the detailed arrangement shown in Fig.3. The input signal from a modulated radio frequency source, having a power level of the order of 10 milli-watts, is fed through an isolating network and into a hybrid T network. This network acts as a power dividing network, feeding equal power into the direct and indirect arms of the network. Each arm contains resistive and reactive elements and the signal outputs are combined by a further hybrid T network which acts as a summing circuit to the signals from the direct and indirect arms. The added signals are further attenuated before being fed to the receiver.

The choice of a carrier frequency of 9.375 Gc/s as the operating frequency of the simulator was made mainly on the availability of equipment operating at that frequency and also because it was approximately in the centre of a wide frequency band which was of interest in a companion study of airborne propagation trials. It has been shown in Section 2.3 that provided the modulation bandwidth can be held so that the effects of frequency dispersion within the waveguide can be kept to a negligible level, the operating frequency is of little interest.

The microwave network is constructed of WG 16 waveguide components and all items other than the dynamic phase-shifter are commercially available parts. The dynamic phase-shifter finally used involved considerable development work and is based on a design by J.C. Cacheris<sup>3,4</sup>. In this, a ferrite mounted in a circular waveguide acts as a differential half-wave phase shifter and when subjected to a transverse rotating magnetic field gives a continuous rotation of the phase or frequency shift to the input signal; the rate of phase shift being controlled by the rate of rotation of the transverse magnetic field. The rotating magnetic field is derived from an electromagnetic circuit which is driven from a phase-quadrature generator and transistorised amplifiers capable of delivering some 750 volt-amperes to each phase of the electromagnetic coil system. The dynamic phase-shifter is described in Appendix B together with another type which was used during the development period of the Cacheris type. This phase-shifter is suitable for giving fading rates of between 0.5 c/s and 200 c/s.

The indirect arm consists of three components; the dynamic phase-shifter, the delay section and the "ground loss" attenuator. The dynamic phase-shifter operates in a reflex mode and its input and output signal flows are controlled by a circulator. The input signal is fed into port 1 and the output at port 2 is fed to the ferrite section of the circulator through a rectangular WG 16 waveguide to a circular waveguide section and a quarter-wave plate section, which transforms the plane wave to a circularly polarised wave at the ferrite section. The ferrite section is terminated by a short circuit causing reflection of the signal. The reflected signal again passes through the ferrite section, the quarter-wave section and the waveguide transform to the circulator where it appears as a plane wave at port 2. The reflected signal incident in port 2 emerges from the circulator at port 3 which is connected to the delay section. The overall loss of the dynamic phase-shifter, including the circulator, is less than 3 dB and the isolation of the circulator is greater than 30 dB.

The delay section consists of 100 metres of WG 16 waveguide and microwave switches allow shorter preset lengths to be selected as required. At 9.375 Gc/s the delay is approximately 4.6 nanoseconds per metre and the loss is about 0.2 dB per metre.

The third component in the indirect path is an attenuator which controls the relative amplitudes of the indirect and direct signal waveforms and hence the depth of signal fading. This control has been referred to as the "ground loss" attenuator since it has a value equal to the additional losses in the reflected path signal compared with the direct path signal in the radio link. This attenuator is variable and a range of 0 to 20 dB is normally available.

To allow the ground loss attenuator to be directly calibrated the other losses in the indirect path are equalised by an attenuator in the direct path having a range of 0 to 40 dB. A phase-shifter having a range of 0 to 360° is also included in the direct path so that static relative phase-shifts may be maintained between the waveforms of the two paths with the dynamic phase-shifter inoperative. This latter condition is useful when recording the receiver output waveforms photographically.

The indirect and direct signal waveforms are combined in a hybrid T junction which acts as a summing circuit. The direct and indirect signals are fed into the ports connected to the main waveguide arms and outputs are obtained in the E and H side arm ports as the sum and difference respectively of the input signals. Since the input signals are added and subtracted vectorially, the signal power available at the two output ports will be equal when averaged over a cycle of fading.

The output is taken from the E side-arm port and fed through a variable attenuator to the receiver. Normally a maximum of 70 dB are available to ensure that the input signal to the receiver can be adjusted to a level comparable to the receiver input noise when required.

The output from the hybrid T junction at the H side-arm port is fed to a diode circuit which acts as a load for that branch and the demodulated signal from the diode gives a useful monitor signal for setting up the dynamic phase-shifter and for equalising the circuit losses of the direct and indirect paths.

A waveguide switch is included in the direct arm and, when the dynamic phase-shifter is being set up, this switch disconnects the direct path circuit from the combining network and terminates it and the open hybrid T port in resistive loads.

The physical layout of the simulator is illustrated in Fig.4. The large 19" rack unit on the left of the photograph contains the two transistorised amplifiers and their associated power units to drive the dynamic phase-shifter. The dynamic phase-shifter unit is the cubic unit immediately below the monitor oscilloscope. The lower section of the bench mounted rack unit contains the low frequency quadrature phased oscillator.

The small rectangular unit to the right of the l.f. oscillator is the microwave frequency generator and its output is transmitted through an isolating unit to the hybrid T junction which divides the microwave power between the upper and lower waveguide arms. The horizontal lower arm consists of two variable attenuators and two variable phase-shifters and a microwave switch. Immediately above this switch is the output hybrid T junction and the ground loss attenuator.

The upper waveguide arm acts as the indirect signal path and feeds into the dynamic phase-shifter and the delay section which consists of the folded waveguide lines, parts of which are shown in the upper part of the photograph. The output from this delay section feeds to the ground loss attenuator which was identified earlier.

The horizontal waveguide from the hybrid T combining junction feeds through a rotary attenuator and two supplementary attenuators before being fed to the receiver unit. Both the signal frequency source and the receiver vary with the type of modulation transmitted and they are not described in this Report.

### 3.3 Summary of simulator facilities

#### 3.3.1 Path difference

Path differences from zero to 100 metres (0 to 0.45  $\mu$ sec) are available in the present model.

#### 3.3.2 Relative power of direct and indirect signal

The indirect signal can be made equal to the direct signal for values of direct signal up to about  $10^{-5}$  W, i.e. about 74 dB above thermal noise in 100 Mc/s.

#### 3.3.3 Range of fade frequencies

The low frequency drive circuits of the ferrite phase-shifter are satisfactory over the frequency range 0.5 c/s to 200 c/s.

### 3.3.4 System bandwidth

The characteristics of the transmission path provide a good approximation to space for system bandwidths up to 100 Mc/s. This may be increased to 200 Mc/s by a change of carrier frequency or waveguide type.

## 4 OPERATION OF THE SIMULATOR

The setting up of the simulator can be divided into three parts. The first operation is the setting up of the dynamic phase-shifter. The second operation is the selection of the required delay and the equalising of the circuit losses in the direct and indirect signal paths. The third operation is the adjustment of the depth of signal fading. When these adjustments are completed using an unmodulated signal source, a modulated signal can then be transmitted through the microwave network and the demodulated signal observed at the receiver output.

Three monitoring points are available for setting up the equipment. Two monitoring points are available to measure the current input to the electromagnetic coils of the dynamic phase-shifter. The third monitoring point is the demodulated signal output from the diode circuit which terminates the H side arm of the output hybrid T junction.

The dynamic phase-shifter is initially adjusted by controlling the input waveform to the dynamic phase-shifter amplifier so that a voltage of 2.8 volts peak-to-peak is observed across the monitor resistance of each coil circuit. This ensures that the major frequency component from the dynamic phase-shifter output is the wanted shifted frequency. The direct path output is disconnected from the combining circuit by means of the microwave switch. The demodulated signal output, at the third monitoring point, is passed through a low frequency chopper circuit and then observed on an oscilloscope. The d.c. amplitude of this chopped signal is proportional to the level of the wanted signal and the amplitude of the ripple is proportional to the level of the unwanted signal components. The input amplitudes of the low frequency waveform to the coil amplifiers are finely adjusted to reduce the amplitude of the observed ripple signal while still maintaining the amplitude of the d.c. component of the rectified waveform. When finally adjusted the ratio of d.c. to ripple amplitudes should exceed 20 dB. The frequency of the low frequency quadrature phased oscillator should be varied over the required frequency range to ensure that this rejection of unwanted signals from the dynamic phase-shifter can be maintained. This completes the setting up of the dynamic phase-shifter.

The direct path circuit should now be switched to the combining network and the required length of waveguide selected for the delay section. The ground

loss attenuator is set to its minimum and the monitor diode output monitored through the chopper circuit. The direct path attenuator should then be adjusted so that the observed fading depth of the monitor signal is 100%. When this is achieved the simulator is ready for use with a modulated signal.

The setting of the ground loss attenuator is adjusted to give the required fading depth; the fading rate is adjusted by setting the low frequency oscillator to half the required fading frequency and the receiver signal amplitude adjusted by the attenuator in the common path in the receiver arm. Values of the setting of the various path parameters can be found from the values derived in Section 2.3 or from practical flight results.

## 5 CONCLUSIONS

1 A simulator has been designed to enable the effects of dual path propagation in radio links to be studied.

2 The characteristics of the simulator enable most situations appropriate to low level launch of televisually guided weapons to be represented. Although the equipment works at a fixed radio frequency the effects of multi-path propagation may be simulated for a wide range of link carrier frequencies.

3 The approximations inherent in the use of waveguide as a delay element are not serious for modulation bandwidths less than 100 Mc/s and delay times less than 0.6 microseconds (600 ft path difference).

4 The much longer time delays associated in the early parts of the trajectory of missiles launched from high altitude aircraft cannot be accurately simulated by the waveguide delay elements except for systems having narrow modulation bandwidths but this is not a serious restriction as the television system would normally be used only in the latter half of the missile trajectory.

## 6 ACKNOWLEDGEMENT

The Cacheris type dynamic phase-shifter described in this Report was developed by Messrs. Elliotts (London) Limited, in their Microwave and Electronic Division, Borehamwood, Herts.

Appendix AMULTI-PATH PROPAGATION OF A SIGNAL1 Propagation over a flat earth

When a sine wave signal of angular frequency ( $w_L$ ) is transmitted to a receiver by two transmission paths, the received signal is the vectorial sum of the signals received. The paths involved are the direct path between the transmitter and the receiver and a reflected path. These paths usually have different lengths and consequently the signals received from the different paths vary in amplitude, phase and relative delay. In general, the transmission between a transmitter and receiver located about a plane earth, will produce at the receiver input at time ( $t$ ) a signal of instantaneous amplitude of

$$a_L = A_1 \cos w_L t + A_2 \cos w_L (t - t_2) . \quad (A.1)$$

Where the power radiated is  $P_L$ , the receiver feeder impedance is  $Z_L$ , the gains of the transmitter and receiver aeriols are ( $G_{T1}$ ) and ( $G_{R1}$ ) respectively in the direction of the direct path and the distance between the transmitter and receiver is ( $R_1$ ) then the amplitude of the direct path signal can be found from the usual free space propagation equation as

$$A_1 = \left[ \lambda (2P_L Z_L G_{T1} G_{R1})^{\frac{1}{2}} \right] / 4\pi R_1 . \quad (A.2)$$

The amplitude ( $A_2$ ) of an indirect path signal can be found from other considerations where a ground reflection coefficient ( $\rho$ ) is introduced to account for the loss in signal power on reflection. Where ( $G_{T2}$ ) and ( $G_{R2}$ ) are the transmitter and receiver gains respectively in the direction of the reflected signal path and ( $R_2$ ) is the total length of the reflected signal path, then the amplitude of this reflected path signal will be

$$A_2 = \left[ \lambda (2P_L Z_L G_{T2} G_{R2} \rho)^{\frac{1}{2}} \right] / 4\pi R_2 . \quad (A.3)$$

Where there are two propagation paths, equations (A.2) and (A.3) can be introduced into equation (A.1) to give the instantaneous amplitude of the signal at the receiver in terms of the propagation paths parameters. Then

$$a_L = \left[ \frac{\lambda (2P_L Z_L G_{T1} G_{R1})^{\frac{1}{2}}}{4\pi R_1} \right] \left[ \cos w_L t + \frac{(G_{T2} G_{R2} \rho)^{\frac{1}{2}} R_1}{(G_{T1} G_{R1})^{\frac{1}{2}} R_2} \cos w_L (t - t_2) \right] . \quad (A.4)$$

The relative delay between the direct and reflected path signal ( $t_2$ ) may be also defined in terms of the propagation path where ( $c$ ) is the velocity of the signal propagation as

$$t_2 = (R_2 - R_1)/c . \quad (A.5)$$

If the transmitter and receiver stations have a separating velocity, then the received signal has a Doppler shift of frequency. The separating velocity when measured over the direct and reflected paths will be different and consequently the Doppler shift of the frequencies of the received signals will be different for each path. This is the equivalent of a continuous rate of relative phase shift between the two path signals and, since they are added vectorially at the receiver, will result in amplitude modulation of the combined signals. This differential Doppler shift frequency is generally known as the fading rate of the signal. Where ( $v_1$ ) and ( $v_2$ ) are the separating velocities of the stations when measured over the direct and reflected path respectively, then the fading rate of the signal will be

$$w_f = w_L (v_2 - v_1)/c . \quad (A.6)$$

The Doppler shift of the signal is generally a very small fraction of the signal frequency and could readily be accommodated by the receiver tuning. The difference in the Doppler shift between the two path signals cannot be compensated for and must be accounted for in the equation for the amplitude of the signal at the receiver. Since the Doppler shift of the signals are of little interest, we can, with negligible loss of accuracy merely add a differential Doppler shift frequency term  $w_f$  to the reflected path signal frequency term, to give instantaneous amplitude of the received signal as

$$a_L = \left[ \frac{\lambda (2P_L Z_L G_{T1} G_{R1})^{\frac{1}{2}}}{4\pi R_1} \right] \left[ \cos w_L t + \frac{(G_{T2} G_{R2} \rho)^{\frac{1}{2}} R_1}{(G_{T1} G_{R1})^{\frac{1}{2}} R_2} \cos (w_L + w_f)(t - t_2) \right] . \quad (A.7)$$

Where the signal transmitted is an unmodulated carrier, equation (A.7) adequately describes the instantaneous voltage at the receiver in terms of the propagation paths parameters.

## 2 Propagation in a microwave network

A microwave network shown in Fig.2 is used to simulate the two transmission paths of a radio link which have been described in the previous paragraph. The signal propagated through the network has a frequency ( $w_s$ ) and the input power ( $P_s$ ) is divided equally between the two arms of the network. The first arm contains an attenuator and phase-shifter and will be referred to as the direct arm. The second arm contains a dynamic phase-shifter, a delay section and an attenuator and will be referred to as the indirect arm. The power gains of the dynamic phase-shifter, the delay section and the attenuator are ( $B_A$ ), ( $B_B$ ) and ( $B_G$ ) respectively, and the gain of the direct arm ( $B_E$ ) is adjusted so that  $B_E = B_A \cdot B_B$ . The outputs from the direct and indirect arms are summed in a combining network from which the output is fed through an attenuator of gain ( $B_C$ ) to the receiver. The dynamic phase-shifter can impress a constant rate of phase or frequency shift ( $w_f$ ) on the signal in the indirect arm. The instantaneous amplitude of the signal at the receiver input will be

$$a_s = A_1 \cos w_s t + A_2 \cos(w_s + w_f)(t - t_2) \quad (A.8)$$

where  $t_2$  is the phase delay of the indirect arm signal with respect to the direct arm signal. Where the impedance of the receiver feeder is  $Z$ , then

$$a_s = (B_C B_E P_s Z)^{\frac{1}{2}} \left[ \cos w_s t + (B_G)^{\frac{1}{2}} \cos(w_s + w_f)(t - t_2) \right] \quad (A.9)$$

Where the signal transmitted is an unmodulated carrier, equation (A.9) describes the instantaneous voltage of the signal at the receiver of the microwave network.

Appendix BDYNAMIC PHASE-SHIFTERS1 General

The requirement for the dynamic phase-shifter for use in the simulator is to produce a frequency shift on the signal in the indirect path of the simulator which is equivalent to the differential Doppler shift of the radio link as described in Appendix A. The differential Doppler shift is different for every frequency component of the modulated signal and it is proportional to the radio frequency of each component of the modulated signal, but the error is very small if the same frequency shift is given to all frequency components to simulate the Doppler shift. The action of the dynamic phase-shifter is the same as a single-side-band generator but since the frequency shift is very small compared with the carrier frequency and the object of the phase-shifter is to control the relative phases of the direct and indirect path waveforms, it is preferable to call the device a dynamic phase-shifter.

A review of the literature indicated that the most suitable device which would meet the requirement was a design by J.C. Cacheris<sup>4,5</sup> which was capable of giving a fixed frequency shift to a microwave signal. This device employs a ferrite as a differential half-wave section mounted in a circular waveguide section. The ferrite when subjected to a rotating transverse magnetic field gives a continuous rate of phase-shift to the circularly polarised waves propagated through it. This device had never been produced commercially and it was necessary to develop it to meet our full requirements, including facilities for varying the frequency shift between limits of less than one to some 200 c/s. During the development period a phase rotation type of phase-shifter was used in the simulator and this produced satisfactory results on frequency modulated signals but its adjustment was both tedious and critical and it was unsuitable for amplitude modulated signals.

Both types of phase-shifters will now be described.

2 The phase rotation method

The phase rotation method of single sideband generation appears to have been discovered independently by R.V. Hartley<sup>6</sup> and M. Chereix<sup>7</sup> and is variously known as the "phase method", "balanced side-band method" and the "Hartley method". The device consists of a microwave network having an arrangement, as shown in Fig.9 consisting of two balanced modulators which are fed in phase quadrature both with respect to the microwave signal and the modulating signal. The output

frequency can be either the sum or the difference of the r.f. and l.f. frequencies. To obtain good suppression of the input signal and unwanted sidebands, the circuit relies on the critical adjustment of the phase relationship and equality of circuit losses in the various circuit branches.

The network was constructed from standard WG 16 waveguide components for operation at a carrier frequency of about 9.375 Gc/s and had an arrangement as shown in Figs.9 and 10. The circuit makes use of four hybrid T junctions, two of which form part of the balanced modulator circuits. The first junction divides the r.f. input signal equally between the upper and lower branches which feed the balanced modulator units.

The balanced modulator units consist of a hybrid T network and two diode units which terminate the main arms of the junction. These diodes are critically biased and are modulated by a low frequency sine wave obtained from a quadrature phased l.f. oscillator. Each modulator unit is driven from a different phase output of the oscillator.

The diode units amplitude modulate the reflected signal in each arm and when recombined in the hybrid T junction the output signal on the H arm of the junction has the form of a double side-band carrier suppressed signal.

When the outputs from each modulator are recombined in a fourth hybrid T network one side-band is suppressed and the other enhanced to give the required output signal which has a frequency differing from that of the input microwave signal by the sine wave modulating frequency. This is obtained only when the phases of the microwave signals in the modulating arms are in quadrature. When correctly adjusted, suppression of the unwanted input signal could be maintained at least 20 dB below the wanted signal level and a somewhat greater suppression could be maintained on the unwanted side-band signal when the microwave input was maintained at a fixed level. Variation of this level changed the bias on the diode units and this was sufficient to unbalance the matching of diode characteristics in the modulators. This restricted the use of the equipment to frequency modulated signals where the signal could be maintained at a constant amplitude.

This equipment was used successfully in an investigation into distortion in frequency modulated signals when propagated through the multi-path network but has been now superseded by the Caoharis type dynamic phase-shifter which will now be described.

### 3 The Cacheris type

The device to be described is an adaption of a rotary phase dynamic phase-shifter described by Cacheris and Dropkin<sup>3,4</sup>. The principle differences from the device described in the literature is the use of a reflex mode of operation and the use of a wide and variable modulating frequency range. Operation of the device relies on the birefringent properties of a ferrite, when subjected to a transverse magnetic field, which cause the propagation constant of the ferrite to differ for planes of polarisation parallel with and perpendicular to the magnetic field. By arranging the ferrite to act as a differential half-wave section providing a rotating magnetic field it is possible to obtain a continuous phase-shift of the wave propagated through the ferrite section.

The principle of operation is illustrated in Fig.11. The input signal consists of a plane wave of frequency  $f_s$  which passes through a quarter wave dielectric plate section to give a circularly polarised wave in a circular waveguide section which contains the ferrite. It is assumed that this wave is rotating in a clockwise direction and the frequency of rotation is  $f_s$ . The ferrite is subjected to a transverse magnetic field rotating at a frequency  $f_o$  and in a counter-clockwise direction. Let the plane of reference be that of the magnetic field. The electric vector will now appear to be rotating at a frequency  $(f_s + f_o)$  but with the direction of rotation reversed as it leaves the ferrite section after reflection. If the plane of reference is now transferred to the fixed dielectric plate the frequency will now appear to be  $(f_s + 2f_o)$  and this is the output frequency of the device.

The circuit arrangement of the dynamic phase-shifter is shown in Fig.12. Since the circuit acts in a reflex mode it is necessary to direct the input and output signals by means of a circulator. The input in arm 1 is directed to arm 2 with a high isolation to arm 3. The rectangular to circular transform is necessary to match the rectangular waveguide input circuit to the circular waveguide ferrite section and the quarter wave dielectric section transforms the plane wave to a circularly polarised wave. The ferrite is housed in the circular waveguide section and is held rigidly in position with foamed material of low dielectric constant. The short circuit terminates the circular section and is adjustable. The action of the quarter wave dielectric plate section and the waveguide transform section is reciprocal and the output signal appears in the rectangular waveguide section as a plane wave having a frequency  $(f_s + 2f_o)$ . This signal is fed into port 2 of the circulator and appears at port 3 with high isolation to port 1.

The rotary magnetic field at the ferrite section is produced by two pairs of coils mounted on a yoke formed by shaped transformer laminations. These coils are excited from a two phase sinusoidal supply, the phases being in quadrature. To avoid high losses by eddy currents the thickness of the circular waveguide wall is reduced to a minimum thickness and the waveguide section is reduced locally.

The power requirements of the magnetic circuit are considerable and these circuits are driven by an amplifier having a maximum capability of 25 volts at 25 amperes into the coil load. Due to the inductive nature of the coil load it has been necessary to restrict the maximum input frequency of the amplifier to 100 c/s with this amplifier. The lower frequency is determined in practice by the lowest available frequency from the quadrature phased oscillator and this is about 0.5 c/s.

The circuit for the amplifier, which is fully transistorised, is shown in Fig.13. Two amplifiers are necessary, one for each phase of the magnetic drive circuit. Extensive use has been made of complimentary symmetry in the amplifier to achieve stability. The amplifier can be considered as two complimentary stages, the upper and lower half operating in a similar fashion. Consider the upper half of the circuit diagram. The input emitter follower  $VT_1$  drives an emitter coupled comparator stage consisting of  $VT_3$ ,  $VT_5$ ,  $VT_8$  and  $VT_9$ . This compares the input signal with that at the emitter of  $VT_{11}$ . Since the 0.1 ohm resistors (R74 and R141) are in series, any changes in the output current through them will be reflected equally as a voltage drop across each. The transistor  $VT_{51}$  serves to transfer the voltage level across R141 to a suitable and adjustable level to drive the comparator stages. The output of the comparator is applied to the base of  $VT_{15}$  which is a unity gain phase-shifter stage to drive the final amplifier stage ( $VT_{21...35}$ ) through a compound emitter follower stage ( $VT_{17}, VT_{19}$ ). All stages are direct coupled and the high current gain of the comparator stages ensure that the current in the magnetic coil circuit is a faithful reproduction of the input waveform and that the amplifier gives a highly stabilised current output. Mains operated stabilised power units give outputs at +5 volts, +10 volts and +30 volts to the amplifiers. The power supplies and the amplifiers are housed in the large 19" rack unit shown in Fig.4. The amplifiers are cooled by a forced air system using two fans.

The electrical requirements for this equipment are given in R.A.E. Specification No. WE 244B which is reproduced at the end of this Appendix and the equipment was developed and constructed by Messrs. Elliott Brothers (London) Limited, in their Microwave and Electronic Division at Borehamwood, Herts. These

requirements have been fully met, the most important for this application being the high value of rejection of the input signal frequency components. In operation the equipment has proved reliable and the setting up procedure is relatively simple.

The setting up procedure consists initially of adjusting the input sine wave from the l.f. oscillator to give a peak to peak sine waveform amplitude of 2.8 volts across the 0.1 ohm monitor resistances in each phase of the coil circuit. The microwave output from the unit is then rectified by a diode circuit and this demodulated signal is then fed through a chopper circuit to a cathode ray tube monitor. The wanted frequency component of the output signal is proportional to the d.c. level of the rectified signal and the unwanted components of the microwave output signal appear as ripples on this d.c. component. The input l.f. sine waveforms are then readjusted to give minimum ripple component while maintaining the d.c. component of the demodulated signal.

#### 4 Specification for the design of an electronically controlled frequency shifter (WE 244)

##### 4.1 General

The requirement is for a laboratory device which can be used to simulate Doppler shift on a low powered modulated microwave signal. The device shall be based on a design described by J.C. Cacheris<sup>4,5</sup>.

The input carrier frequency shall be 9.375 Mc/s and the required Doppler shift shall be between 0.1 c/s and 200 c/s. The device shall be capable of giving the frequency shift by a continuous uniform variation of phase of the input signal which shall be determined by two quadrature phased signals having a frequency equal to half the required Doppler shift frequency.

The device shall include a phase shifting component, in a circularly polarised microwave field, and the necessary matching and circular polarising elements. The phase-shifting component shall consist of a ferrite rod situated in a rotating magnetic field derived from two magnetic circuits fed with quadrature phased low frequency signals. The necessary magnetic circuit drive amplifiers will form part of this device.

The input and output parts shall be suitable for connecting to other WG 16 round flange waveguide components and these parts shall be mechanically aligned.

##### 4.2 Input signals

The input r.f. and low frequency signals shall be as specified below:-

#### 4.2.1 R.f. input signal

The r.f. input signal shall have a nominal frequency of 9.375 Mc/s. This may be amplitude or frequency modulated by a complex video waveform. The r.f. power level may vary between 10 microwatts and one watt. The frequency spectrum of the modulated signal may be  $\pm 50$  Mc/s on the nominal carrier frequency.

#### 4.2.2 Magnetic circuit drive

The input to this circuit will be derived from a quadrature phased sine wave signal generator having a frequency range 0.05 c/s to 100 c/s. The quadrature phase input signals shall have an amplitude of one volt and the generator shall have a nominal source impedance of 600 ohms.

Any frequency/amplitude compensation necessary to maintain the correct magnetic field conditions on the ferrite section shall be incorporated within the magnetic circuit drive amplifier.

#### 4.3 Performance requirements

The equipment shall be designed to meet the following requirements:-

4.3.1 The r.f. output having a frequency which has been shifted twice the quadrature-phased generator frequency shall be not more than 3 dB down on the r.f. input level.

4.3.2 The r.f. output having a frequency of the r.f. input shall be at least 20 dB down on the output measured in 3.1.

4.3.3 The r.f. output at any frequency other than those measured in 3.1 and 3.2 shall be at least 30 dB down on that measured in 3.1.

#### 4.4 Setting-up procedure and calibration stability

It is a requirement that any routine setting up procedure shall be reasonably simple and adequate monitoring circuits shall be incorporated to achieve this. The device shall be capable of maintaining the specification performance for several hours without adjustment at normal room temperature. This performance shall be maintained

- (a) for high levels of amplitude modulation,
- (b) for frequency deviations of up to  $\pm 50$  Mc/s,
- (c) for a magnetic circuit drive frequency continuously variable between 0.1 c/s and 1000 c/s. A maximum rate of change of this frequency will be one decade of frequency per 10 seconds.

SYMBOLS

$a_L$	=	instantaneous amplitude of the received radio link signal
$a_s$	=	instantaneous amplitude of the received simulator signal
$A_1$	=	amplitude of the direct path signal
$A_2$	=	amplitude of the reflected or indirect path signals
$B_A$	=	power gain of the dynamic phase-shifter
$B_B$	=	power gain of the delay section
$B_C$	=	power gain of the receiver arm attenuator
$B_E$	=	power gain of equalising attenuator
$B_G$	=	power gain of the ground loss attenuator
$c$	=	velocity of light ( $3 \cdot 10^8$ metres per second)
$f_b$	=	bandwidth of the waveguide
$f_o$	=	frequency of waveform driving the dynamic phase-shifter coil circuit
$f_s$	=	frequency of carrier
$G_{R1}$	=	power gain of the receiver aerial in the direction of the direct path
$G_{R2}$	=	power gain of the receiver aerial in the direction of the reflected path
$G_{T1}$	=	power gain of the transmitter aerial in the direction of the direct path
$G_{T2}$	=	power gain of the transmitter aerial in the direction of the reflected path
$h_r$	=	height of the receiver above ground
$h_t$	=	height of the transmitter above ground
$l$	=	length of waveguide
$l_1$	=	length of waveguide in the direct arm
$l_2$	=	length of waveguide in the indirect arm
$P_L$	=	power transmitted into the radio link
$P_s$	=	power transmitted into the simulator
$R$	=	horizontal range between transmitter and receiver
$R_o$	=	free space distance
$R_1$	=	length of the direct radio link path
$R_2$	=	length of the reflected radio link path (adjusted to allow for phase change at reflecting surface)
$t$	=	time
$t_2$	=	relative delay of modulation information between two signal paths
$v_1$	=	velocity of separation measured over the direct path
$v_2$	=	velocity of separation measured over the reflected path
$v_g$	=	group velocity of signal in the waveguide

SYMBOLS (CONTD)

$v_p$	=	phase velocity of the waveform in the waveguide
$w$	=	angular frequency ( $w = 2\pi f_b$ )
$w_o$	=	angular cut-off frequency of the waveguide = $2\pi f_c$
$w_f$	=	angular fading frequency of signal = $2\pi f_f$
$w_L$	=	angular frequency of the radio link transmitter carrier
$w_s$	=	angular frequency of the simulator transmitter carrier = $2\pi f_s$
$x$	=	$w_c/w_s$
$Z$	=	impedance of the feeder to the simulator receiver
$Z_L$	=	impedance of the feeder to the radio link receiver
$\lambda$	=	wavelength of the radio link carrier
$\rho$	=	power reflection coefficient in the reflected path
$\Delta\phi$	=	differential phase-shift

BIBLIOGRAPHY

<u>No.</u>	<u>Author</u>	<u>Title, etc</u>
1	H. Drysdale	The distortion of step waveforms in a frequency modulated television system due to propagation by two paths. R.A.E. Technical Report No.64031
2	A.E. Karbowskiak	Propagation of transient in waveguides. Proc. I.E.E. Vol.104 Part C. p.339, February 1957
3	M.F. Packer	Factors affecting the choice of transmitter frequency for a missile television data link. R.A.E. Technical Report No.65063
4	J.C. Cacheris	Microwave single sideband modulator using ferrites. Proc. I.R.E. Vol.42, August 1954
5	J.C. Cacheris H.A. Dropkin	Compact microwave single sideband modulator using ferrites. I.R.E. Transactions. Microwave Theory and Technology. Vol.MTT-4 No.3, July 1956
6	R.V. Hartley	U.S.A. Patents No.1,666,206, 1928
7	M. Chereix	French Patent No.708,058, 1930

---

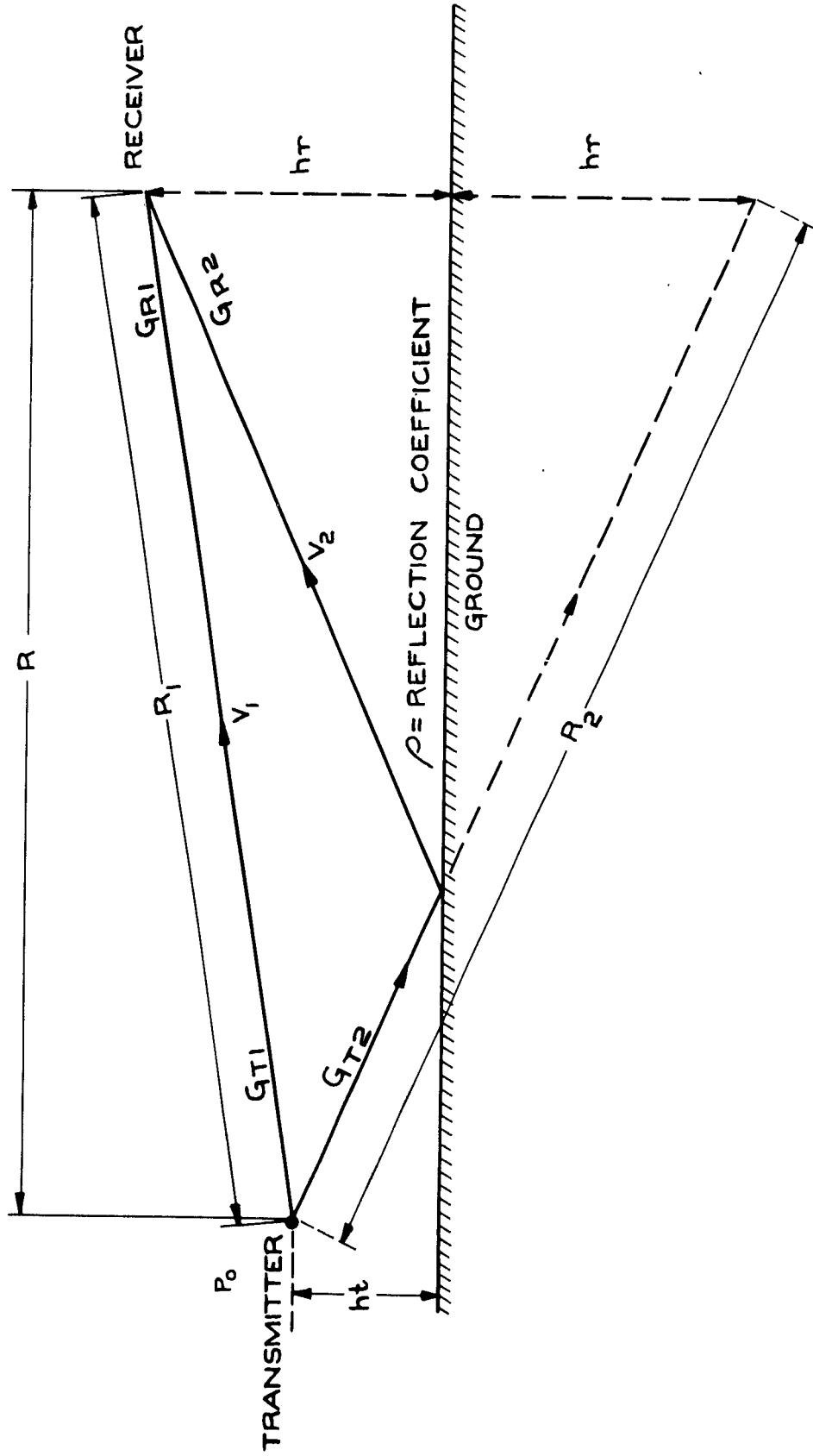

FIG.1 PROPAGATION OF A CARRIER BY TWO PATHS

Fig.2

CONFIDENTIAL  
WER 7071

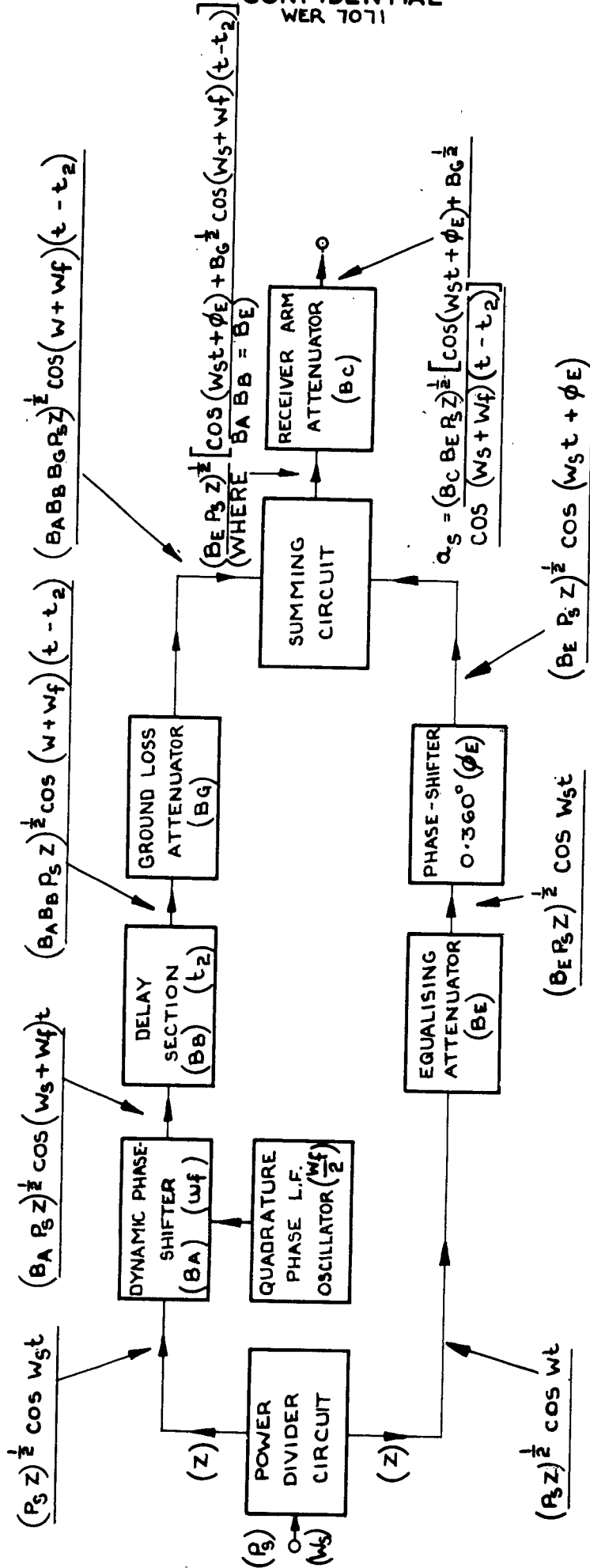

FIG. 2 SIMULATION OF MULTIPATH PROPAGATION BY A MICROWAVE NETWORK

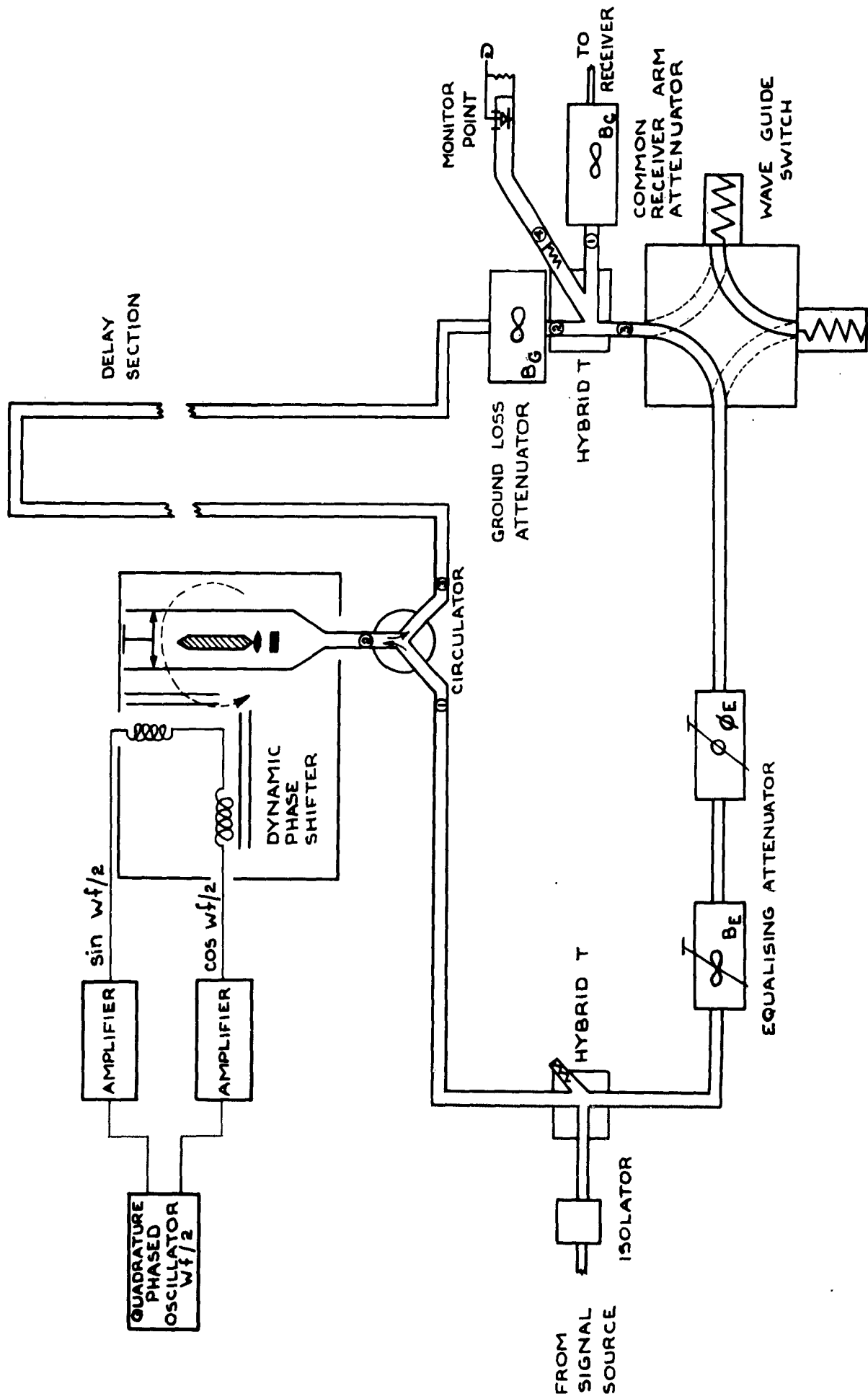

FIG. 3 SCHEMATIC DIAGRAM OF SIMULATOR

Fig.4

Neg. No. C1781



Fig.4. Micro-wave network

Fig.4

Neg. No. C1781

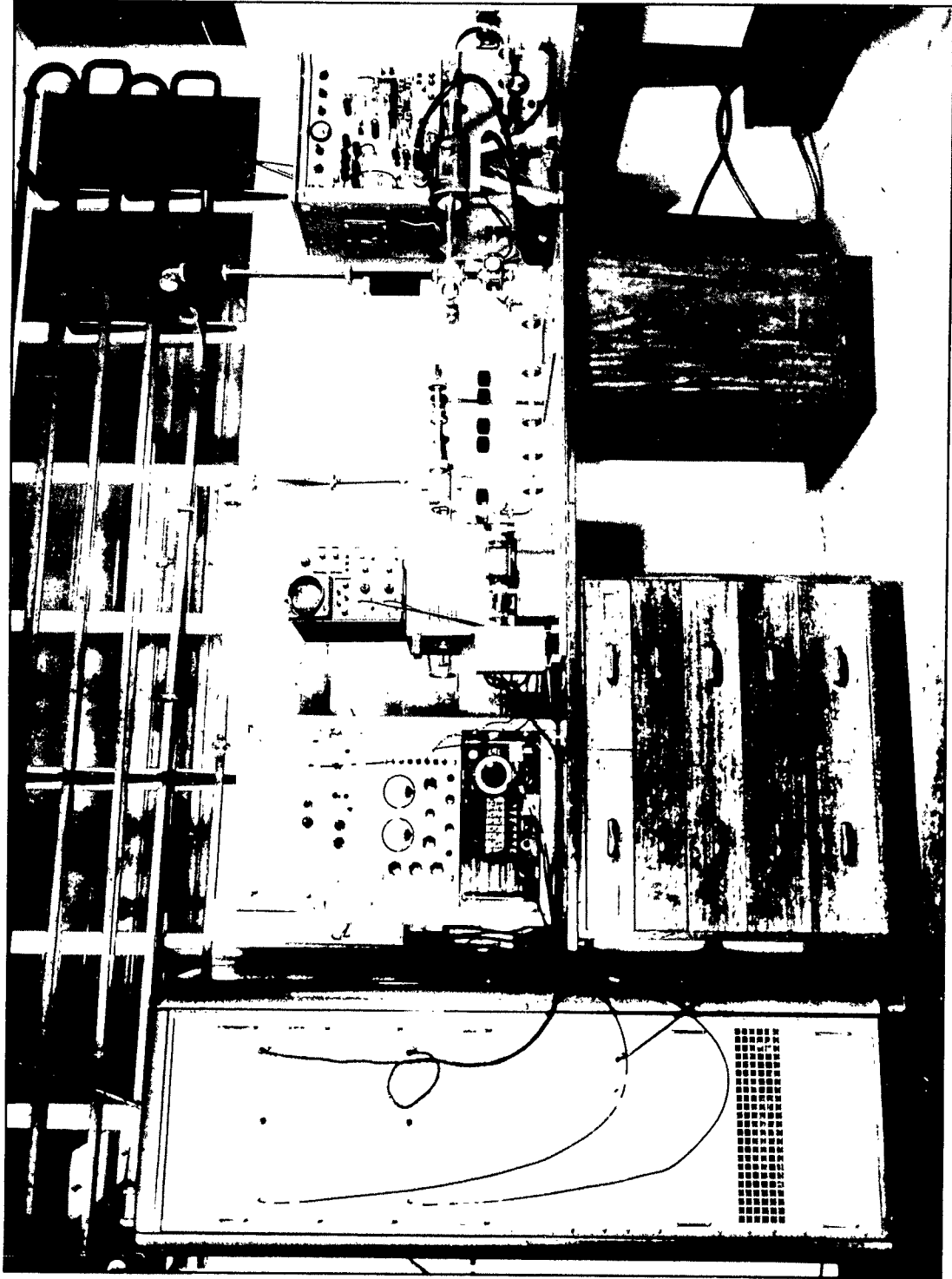

Fig.4. Micro-wave network

Fig. 5

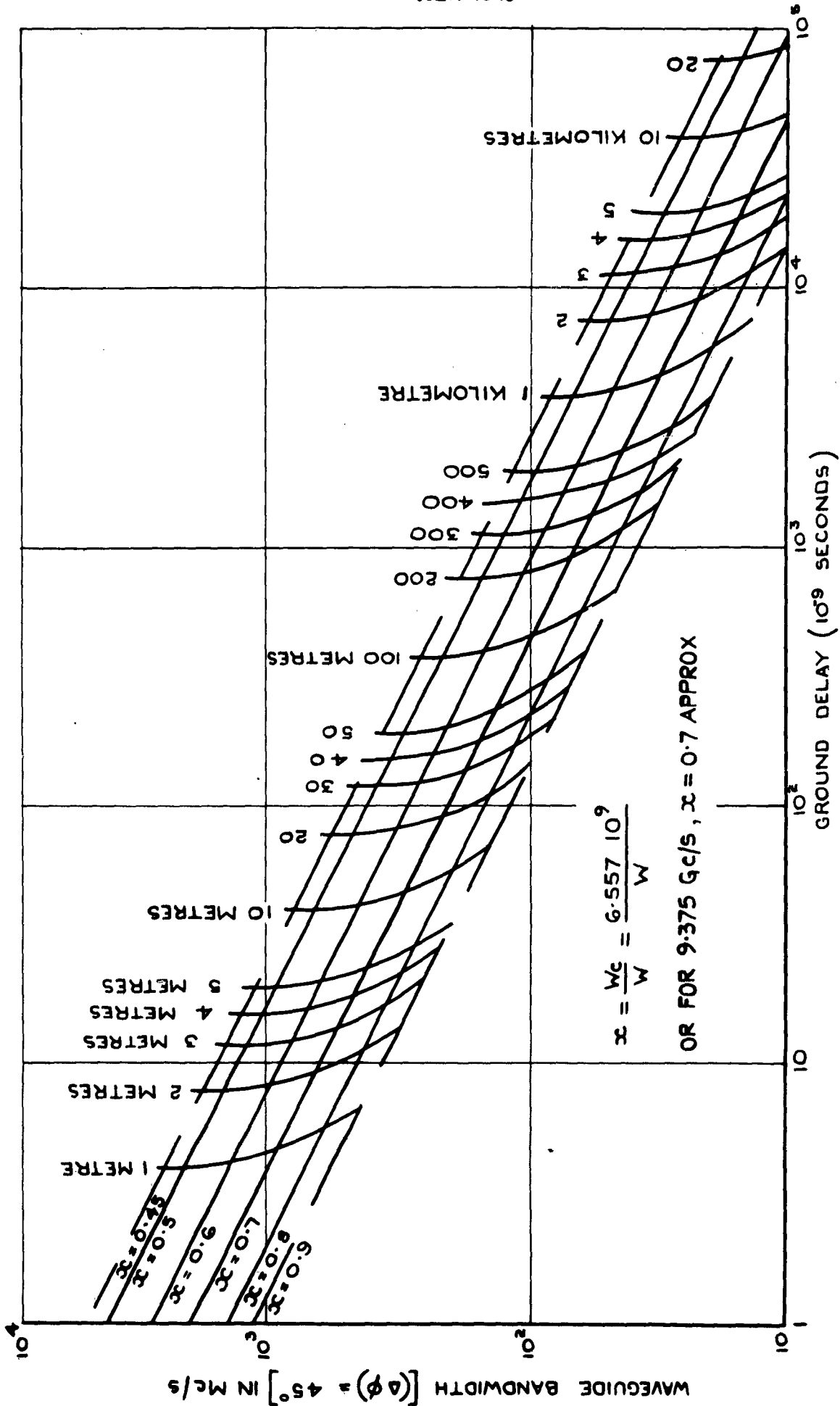

FIG.5 RELATIONSHIP BETWEEN WAVEGUIDE BANDWIDTH, GROUP DELAY, LENGTH OF WAVEGUIDE AND FREQUENCY

Fig.6

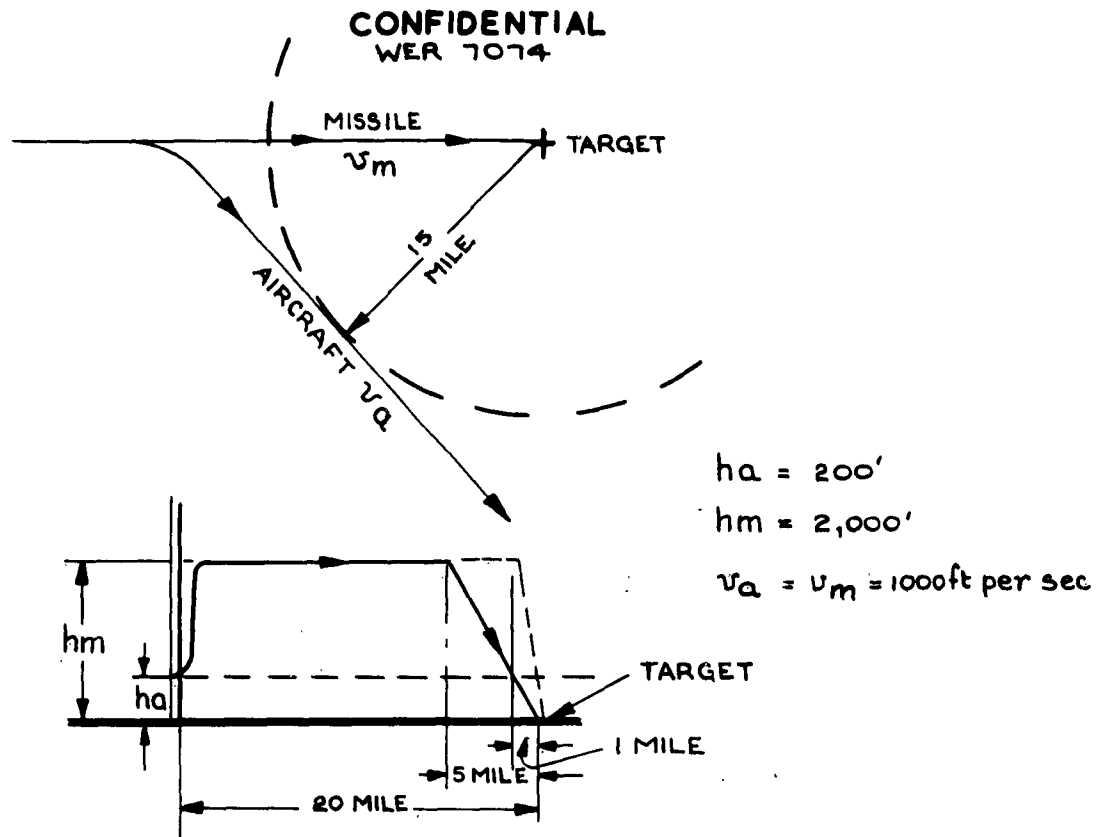

FIG. 6 (a) LOW LEVEL RELEASE OF MISSILE

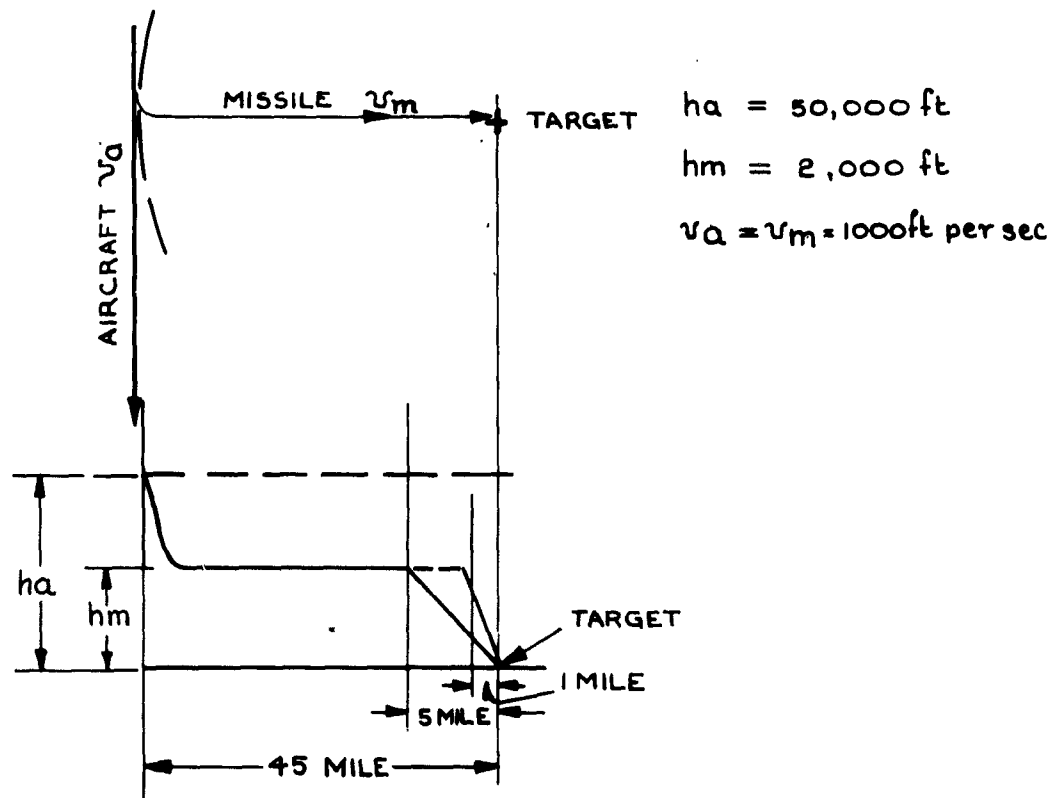

FIG. 6 (b) HIGH LEVEL RELEASE OF MISSILE

FIG.6 APPROXIMATED AIRCRAFT-MISSILE TRAJECTORIES

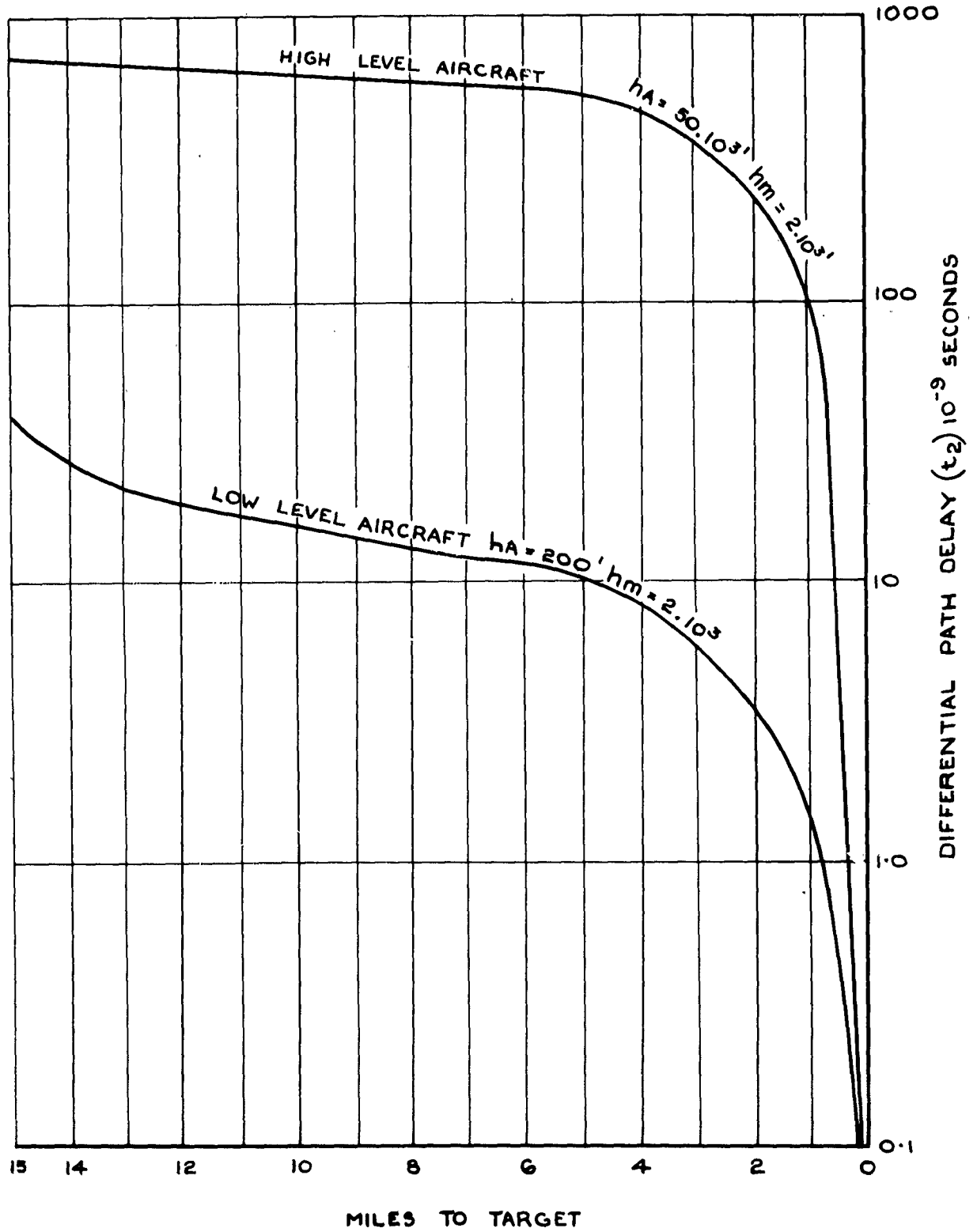

FIG. 7 VARIATION OF VALUE OF PATH DIFFERENCE FOR TYPICAL HIGH AND LOW ALTITUDE LAUNCH CONDITIONS

Fig.8

CONFIDENTIAL  
WER 1076

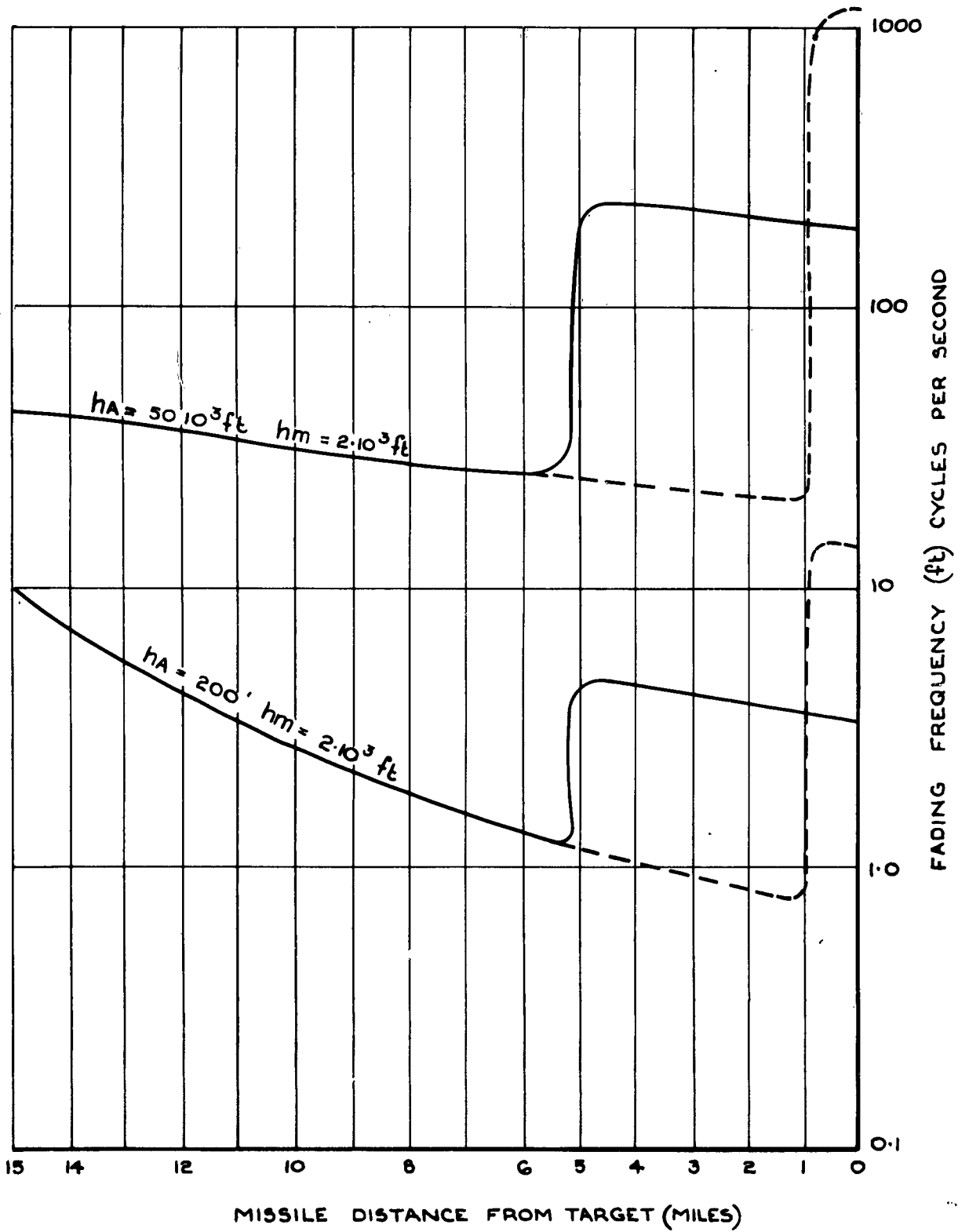

FIG. 8 VARIATION OF FADE FREQUENCY FOR TYPICAL HIGH AND LOW ALTITUDE LAUNCH CONDITIONS [Y BAND]

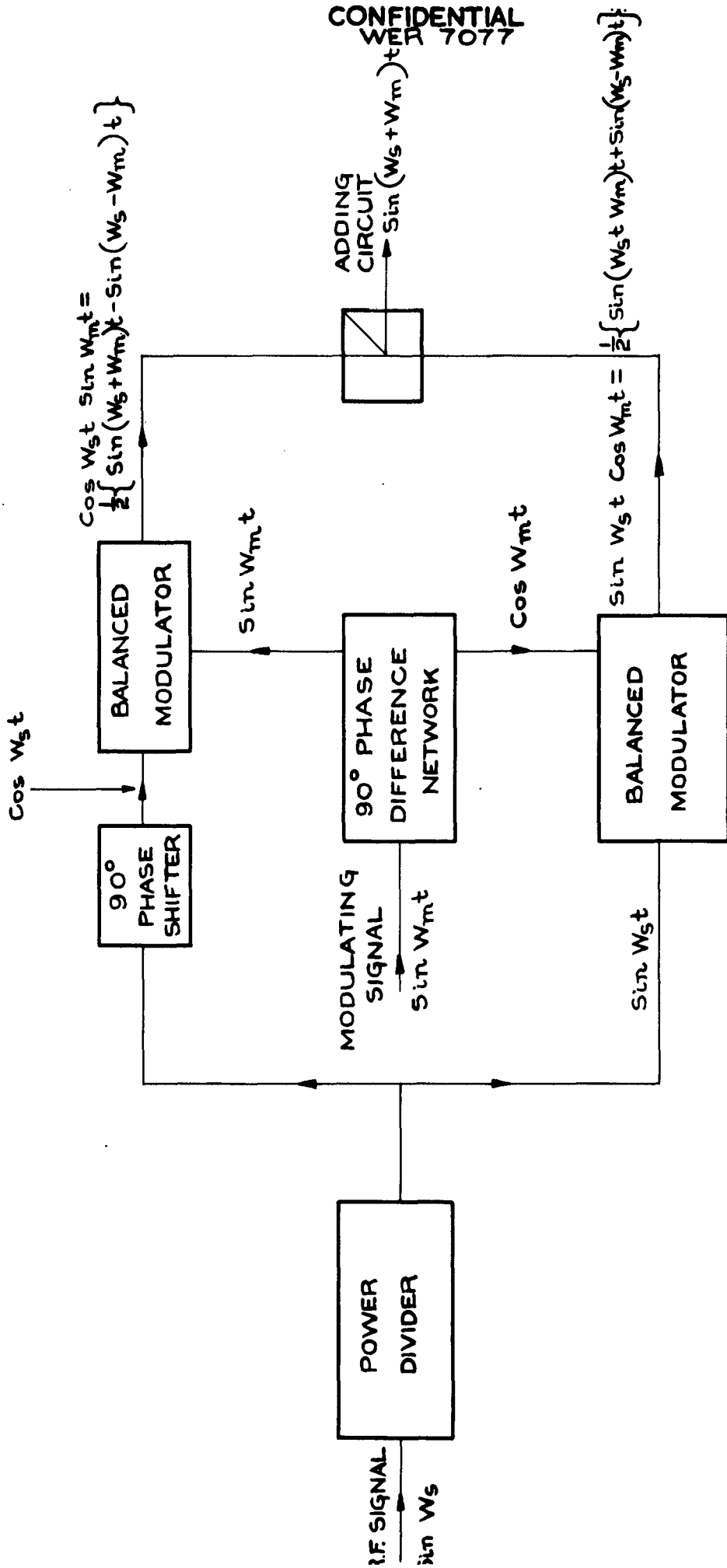

FIG.9 BLOCK DIAGRAM OF PHASE ROTATION TYPE DYNAMIC PHASE SHIFTER

Fig.9

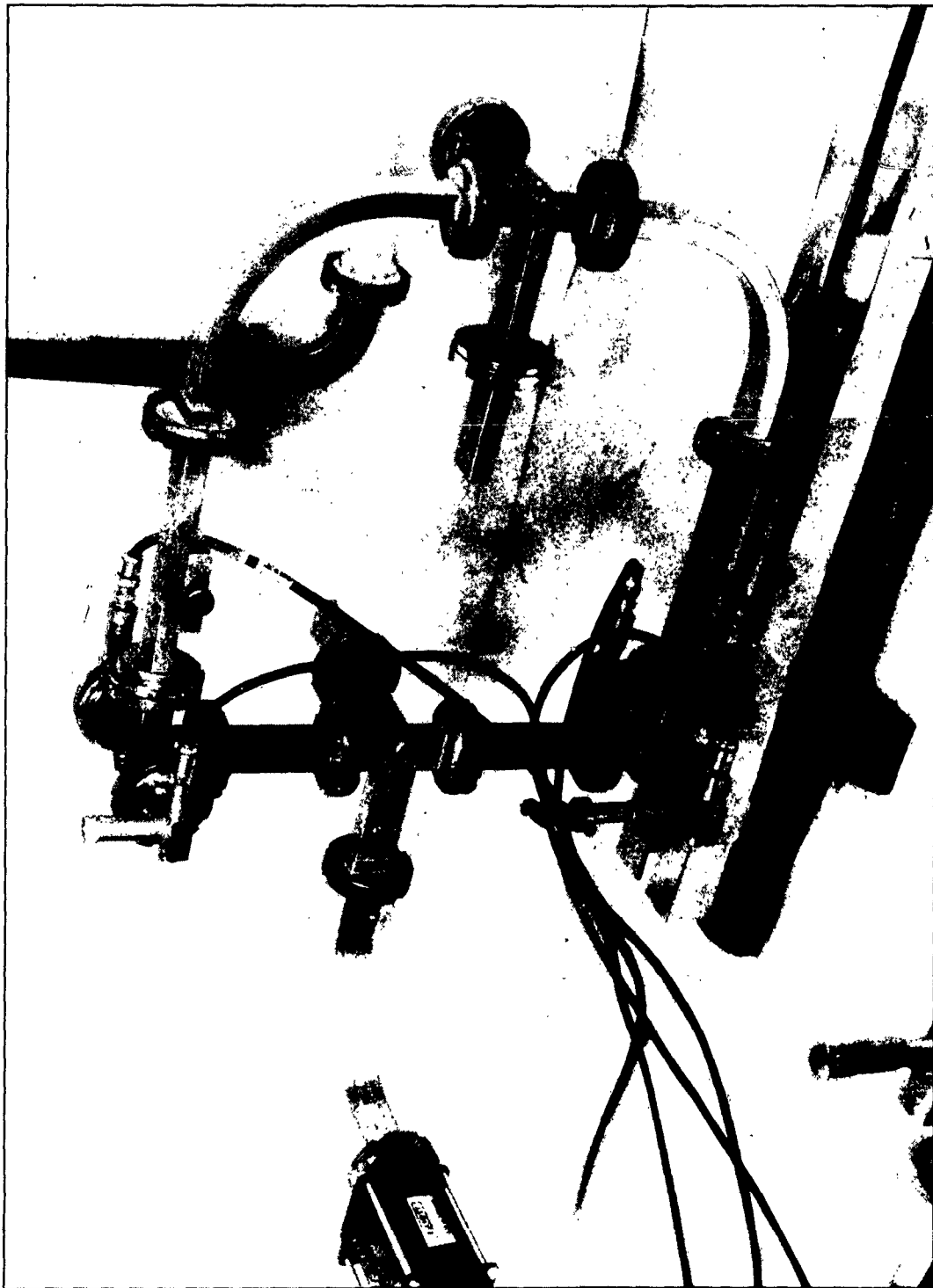

Fig.10. Phase rotation type dynamic phase-shifter

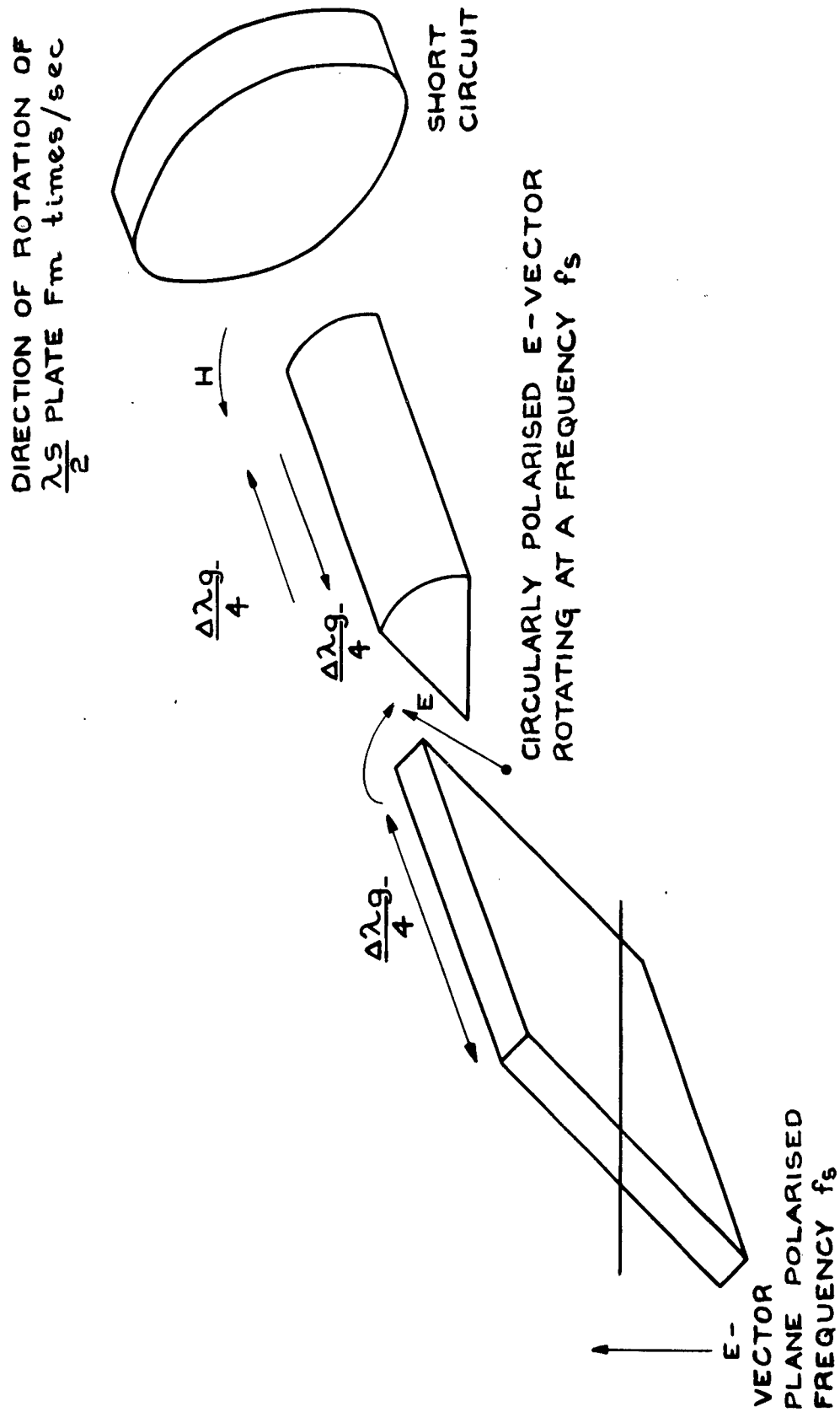

FIG. 11 PRINCIPLE OF CACHERIS TYPE DYNAMIC PHASE-SHIFTER

Fig.12

CONFIDENTIAL  
WER 7079

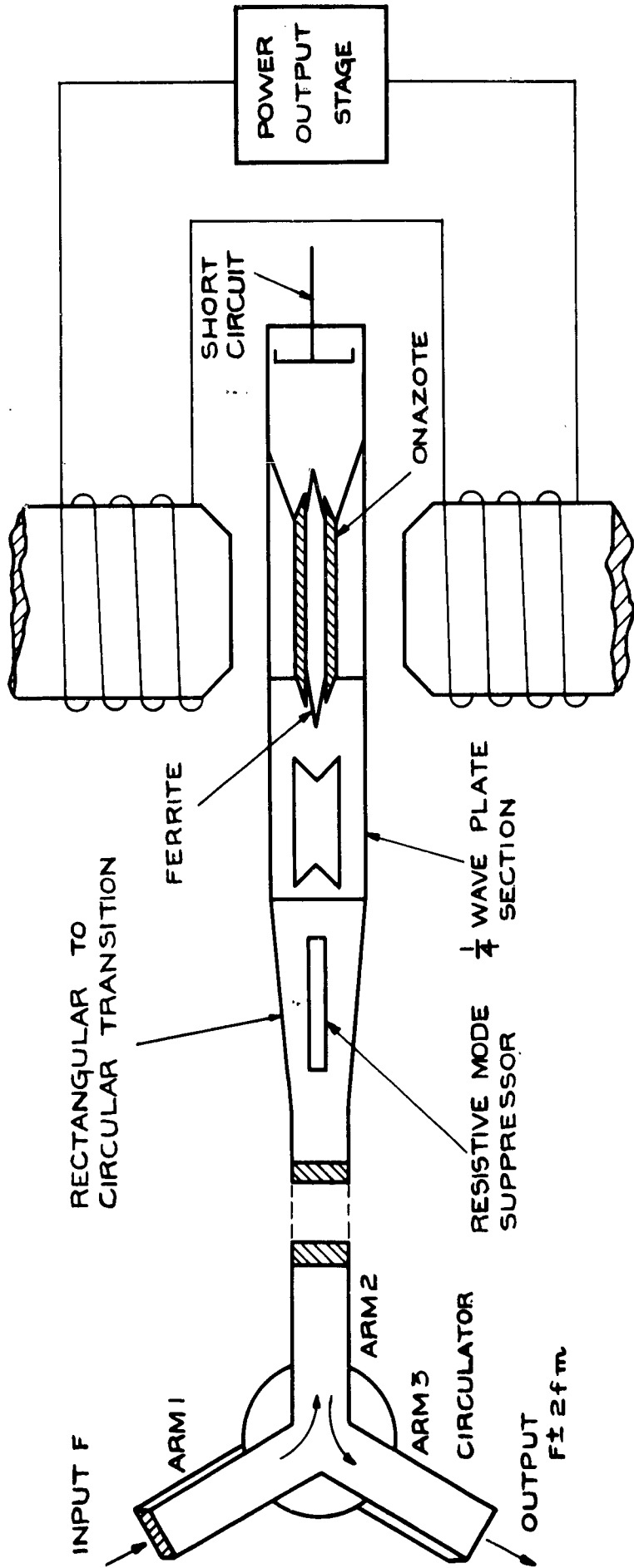

FIG. 12 SCHEMATIC OF CACHERIS TYPE DYNAMIC PHASE-SHIFTER

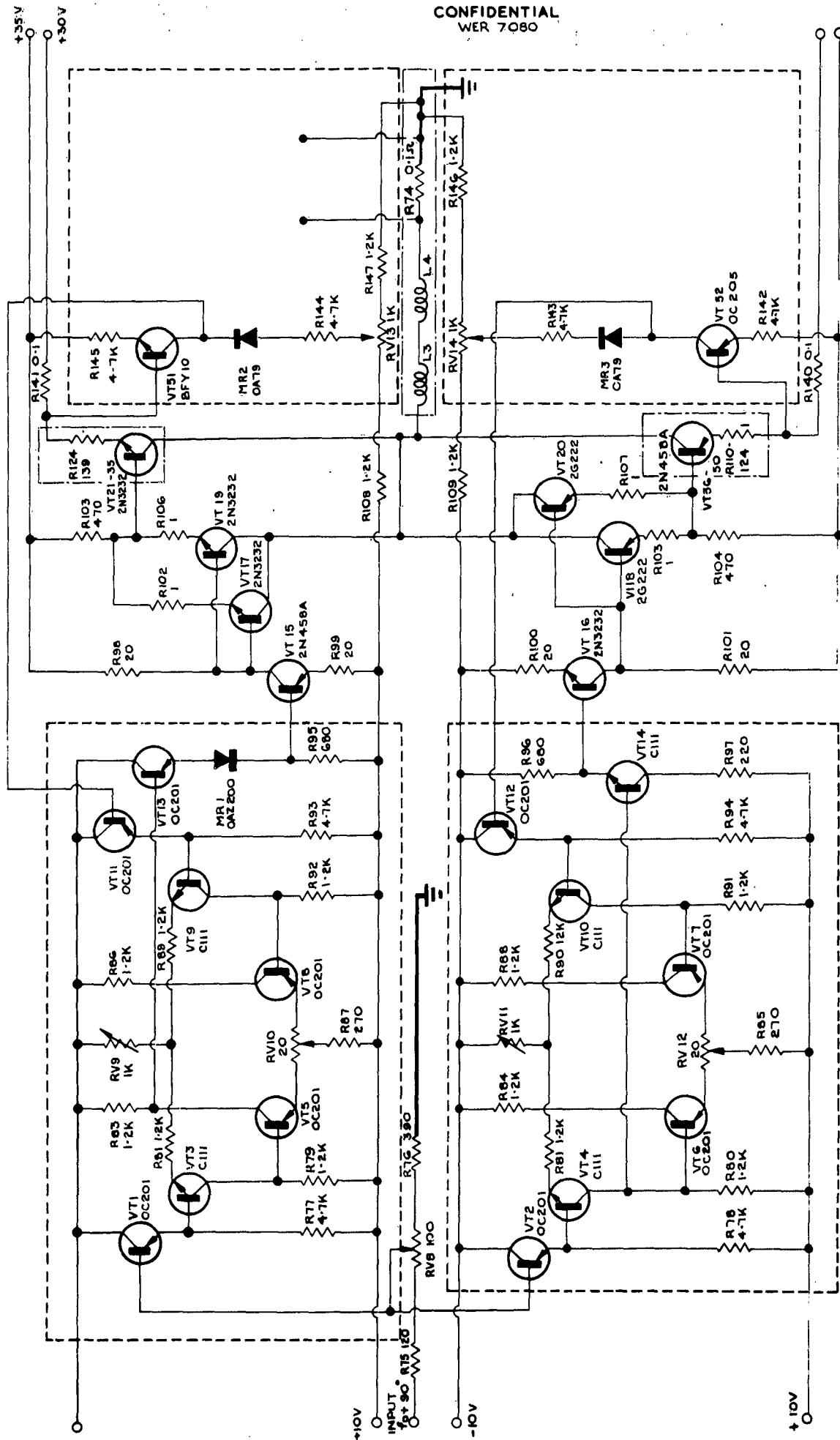

FIG. 13 CIRCUIT DIAGRAM OF COIL AMPLIFIER

DETACHABLE ABSTRACT CARDS

These abstract cards are inserted in Technical Reports for the convenience of Librarians and others who need to maintain an Information Index.

Detached cards are subject to the same Security Regulations as the parent document, and a record of their location should be made on the inside of the back cover of the parent document.

<p align="center">CONFIDENTIAL</p> <p>Hosie, G. W.</p> <p>SIMULATION OF MULTI-PATH DISTORTION OF A MODULATED CARRIER SIGNAL USING A MICROWAVE NETWORK</p> <p>Royal Aircraft Establishment Technical Report 66078</p> <p align="right">March 1966</p> <p>Televisually guided air to surface weapons employ radio links to convey guidance pictures from the missile to the aircraft and command signals from the aircraft to the missile. The signals received via these links are subject to fading and distortion due to the simultaneous reception of signals transmitted by the direct path and signals reflected from the ground or other objects.</p> <p>A laboratory equipment has been designed to enable the effects of dual path propagation to be studied. Descriptions are given of the transmission</p> <p align="right">CONFIDENTIAL (Over)</p>	<p align="center">CONFIDENTIAL</p> <p>Hosie, G. W.</p> <p>SIMULATION OF MULTI-PATH DISTORTION OF A MODULATED CARRIER SIGNAL USING A MICROWAVE NETWORK</p> <p>Royal Aircraft Establishment Technical Report 66078</p> <p align="right">March 1966</p> <p>Televisually guided air to surface weapons employ radio links to convey guidance pictures from the missile to the aircraft and command signals from the aircraft to the missile. The signals received via these links are subject to fading and distortion due to the simultaneous reception of signals transmitted by the direct path and signals reflected from the ground or other objects.</p> <p>A laboratory equipment has been designed to enable the effects of dual path propagation to be studied. Descriptions are given of the transmission</p> <p align="right">CONFIDENTIAL (Over)</p>
<p align="center">CONFIDENTIAL</p> <p>Hosie, G. W.</p> <p>SIMULATION OF MULTI-PATH DISTORTION OF A MODULATED CARRIER SIGNAL USING A MICROWAVE NETWORK</p> <p>Royal Aircraft Establishment Technical Report 66078</p> <p align="right">March 1966</p> <p>Televisually guided air to surface weapons employ radio links to convey guidance pictures from the missile to the aircraft and command signals from the aircraft to the missile. The signals received via these links are subject to fading and distortion due to the simultaneous reception of signals transmitted by the direct path and signals reflected from the ground or other objects.</p> <p>A laboratory equipment has been designed to enable the effects of dual path propagation to be studied. Descriptions are given of the transmission</p> <p align="right">CONFIDENTIAL (Over)</p>	<p align="center">CONFIDENTIAL</p> <p>Hosie, G. W.</p> <p>SIMULATION OF MULTI-PATH DISTORTION OF A MODULATED CARRIER SIGNAL USING A MICROWAVE NETWORK</p> <p>Royal Aircraft Establishment Technical Report 66078</p> <p align="right">March 1966</p> <p>Televisually guided air to surface weapons employ radio links to convey guidance pictures from the missile to the aircraft and command signals from the aircraft to the missile. The signals received via these links are subject to fading and distortion due to the simultaneous reception of signals transmitted by the direct path and signals reflected from the ground or other objects.</p> <p>A laboratory equipment has been designed to enable the effects of dual path propagation to be studied. Descriptions are given of the transmission</p> <p align="right">CONFIDENTIAL (Over)</p>

CONFIDENTIAL

paths and expressions derived to enable the parameters of the microwave simulator to be determined. The limitations of accurate simulation of multi-path propagation are examined and it is shown that the errors are small where the signal modulation bandwidth does not exceed 100 Mc/s.

CONFIDENTIAL

paths and expressions derived to enable the parameters of the microwave simulator to be determined. The limitations of accurate simulation of multi-path propagation are examined and it is shown that the errors are small where the signal modulation bandwidth does not exceed 100 Mc/s.

CONFIDENTIAL

CONFIDENTIAL

paths and expressions derived to enable the parameters of the microwave simulator to be determined. The limitations of accurate simulation of multi-path propagation are examined and it is shown that the errors are small where the signal modulation bandwidth does not exceed 100 Mc/s.

CONFIDENTIAL

CONFIDENTIAL

paths and expressions derived to enable the parameters of the microwave simulator to be determined. The limitations of accurate simulation of multi-path propagation are examined and it is shown that the errors are small where the signal modulation bandwidth does not exceed 100 Mc/s.

CONFIDENTIAL

CONFIDENTIAL



*Information Centre  
Knowledge Services*  
**[dstl]** *Porton Down,  
Salisbury  
Wiltshire  
SP14 6JG  
22060-6218  
Tel: 01980-613733  
Fax 01980-613970*

Defense Technical Information Center (DTIC)  
8725 John J. Kingman Road, Suit 0944  
Fort Belvoir, VA 22060-6218  
U.S.A.

AD#: AD 396965

Date of Search: 15 December 2008

Record Summary: AVIA 6/22680

Title: Simulation of multi-path distortion of a modulated carrier signal using a microwave network

Former reference (Department): 66078

Held by The National Archives, Kew

This document is now available at the National Archives, Kew, Surrey, United Kingdom.

DTIC has checked the National Archives Catalogue website (<http://www.nationalarchives.gov.uk>) and found the document is available and releasable to the public.

Access to UK public records is governed by statute, namely the Public Records Act, 1958, and the Public Records Act, 1967.

The document has been released under the 30 year rule.

(The vast majority of records selected for permanent preservation are made available to the public when they are 30 years old. This is commonly referred to as the 30 year rule and was established by the Public Records Act of 1967).

This document may be treated as **UNLIMITED**.